



# REACH-IN DOOR MERCHANDISERS

INSTALLATION & OPERATIONS MANUAL

**RF / RF-N**



## IMPORTANT

Keep in store for future reference!

[www.turboairinc.com](http://www.turboairinc.com)

# REVISION HISTORY

---

VERSION 1.0

- New manual

# TABLE OF CONTENTS

GENERAL INFORMATION .....	4
Safety Notice	
General Information	
INSTALLATION .....	5
Remove Casters	
Leveling	
Remove Parts	
Apply Gasket	
Align End Frames	
Fasten End Frames	
Install Kickplate	
REFRIGERATION .....	7
Refrigerant Piping	
Refrigeration Thermostat	
Electric Defrost	
Plumbing	
ELECTRICAL .....	9
Field Wiring	
OPERATION .....	10
Shelf	
Load Limit	
MAINTENANCE .....	11
Case Cleaning	
APPENDIX .....	12
RF/RF-N Electrical Data & Case Dimensions	

# GENERAL INFORMATION

## SAFETY NOTICE

All warning messages will inform you of the potential hazard; how to reduce the risk of case damage, personal injury or death; and what may happen if the instructions are not properly followed.

- **DANGER** – Indicate[s] a hazardous situation which, if not avoided, will result in death or serious injury.
- **WARNING** – Indicate[s] a hazardous situation which, if not avoided, could result in death or serious injury.
- **CAUTION** – Indicate[s] a hazardous situation which, if not avoided, could result in minor or moderate injury.

## GENERAL INFORMATION

### • STORE CONDITIONS

Cases are designed to operate in an air-conditioned store that maintains a 75°F (24°C) store temperature and 55% (max) relative humidity. Case operation will be adversely affected by exposure to excessively high ambient temperatures and/or humidity.

ANSI/NSF-7 Type I – Display Refrigerator / Freezer Intended for 75°F / 55%RH Ambient Application

### • REFRIGERATION SYSTEM OPERATION

Air-cooled condensing units require adequate ventilation for efficient performance. Machine-room temperatures must be maintained at a minimum of 65°F in winter and a maximum of 95°F in summer. Minimum condensing temperatures should be no less than 70°F.

### • EXTERIOR LOADING

Do not walk on top of merchandisers. It could damage the cases and serious personal injury could occur. They are not structurally designed to support excessive external loading such as the weight of a person. Do not place heavy objects on the merchandiser.

### • SERIAL NUMBER LOCATION

The serial number is located in left top inside of cabinets.

### • SHIPPING DAMAGE

All equipment should be thoroughly examined for shipping damage before and during unloading. Any claim for loss or damage must be made to the carrier. The carrier will provide any necessary inspection reports and/or claim forms. Claims for obvious damage must be noted on either the freight bill or the express receipt and signed by the carrier's agent; otherwise, the carrier may refuse the claim. If damage becomes apparent after the equipment is unpacked, retain all packing materials and submit a written request to the carrier for inspection within 14 days of receipt of the equipment.

### • LOST/MISSING ITEMS

Any claim for missing items must be made to Texaking within 48 hours of receipt of the equipment.

# INSTALLATION

## 1) REMOVE CASTERS

- Leave a minimum of 3" between the wall and back of case. Using a J bar, raise the end of the case, remove the caster assembly (Fig. 1) and lower the base on to the shims. Repeat on the other end of the case.

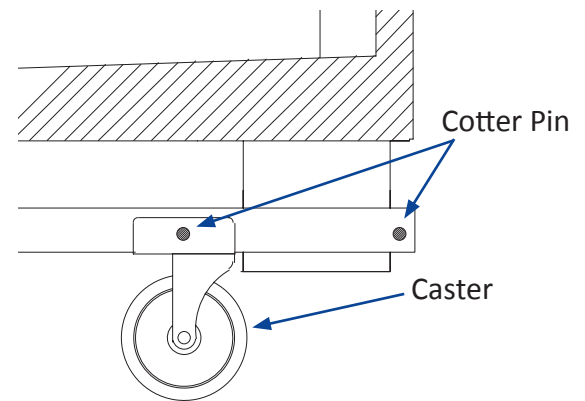

Fig 1. Removing Casters

## 2) LEVELING

- Once the base is properly placed on the shims, check the vertical plumb of the case by placing a bubble level on the rear wall. Add/remove shims as needed. For the horizontal level, repeat this process after placing the bubble level on the front. (Fig. 2)

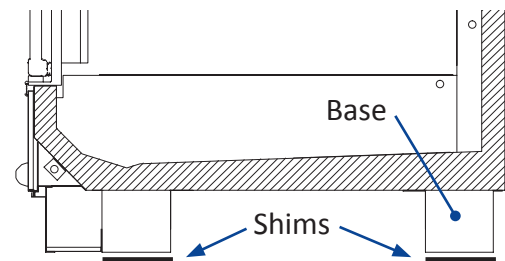

Fig 2. Leveling

## 3) REMOVE PARTS

- Remove shelves, kickplate, pans, wire screens and return air grilles from the right end.

## 4) APPLY GASKETS

- Apply the 1 inch gasket around the perimeter of the case as shown Fig. 3. It must be at the edge. Check to be sure that there are no gaps between gasket and case.
- A continuous bead of silicone sealant/caulk may be used in addition to gaskets on mating surfaces but must not be used in lieu of gaskets.

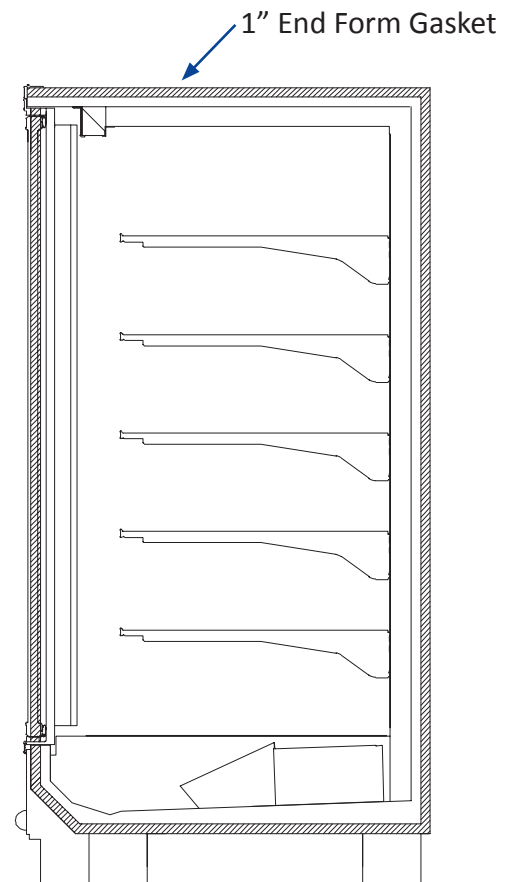

Fig 3. Gaskets Location

# INSTALLATION

## 5) ALIGN CANOPY HOOD

- Move the second case as close to the first as possible by pushing or using lever bar.
- Insert the alignment rod (1/8in diameter) through holes in canopy hood as shown Fig. 4

Insert Alignment Rod  
(1/8" diameter)

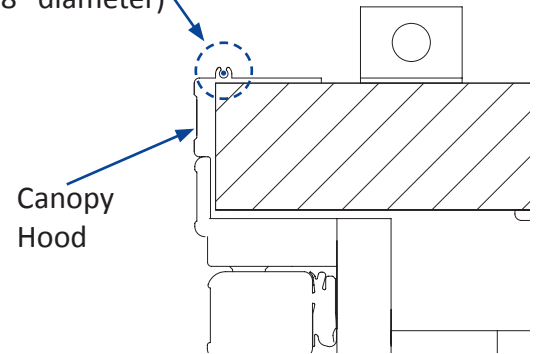

Fig 4. Alignment Rod Location

## 6) FASTEN END FRAMES

- Push the cases tightly together, then lightly bolt them together through the holes that are provided. (Fig. 5) Tighten all the joining bolts until all margins are equal.

#1~#6 Bolts Specification  
5/16" diameter x 3in bolts  
5/16" Washer/lock washers  
5/16" nuts

#7~#8 Bolts Specification  
5/16" diameter x 8in bolts  
5/16" Washer/lock washers  
5/16" nuts

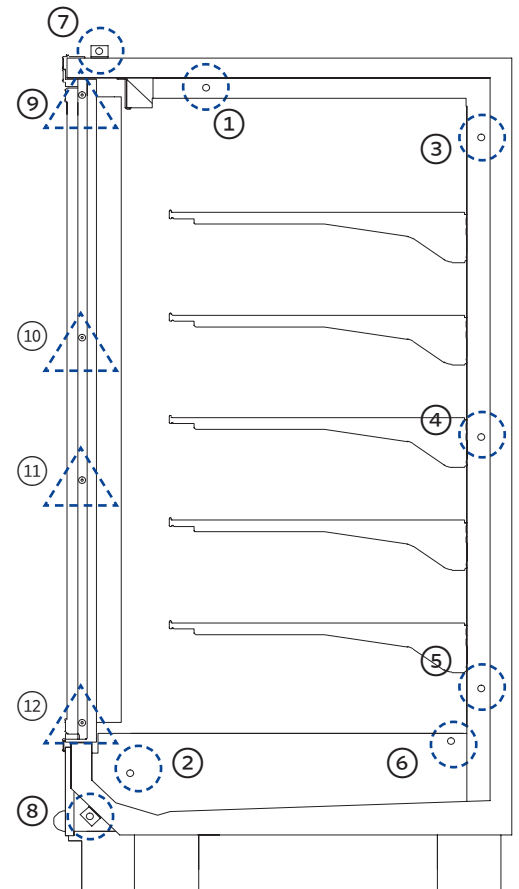

Fig 5. Bolting Location

## 7) INSTALL KICKPLATE

- The kickplate is shipped inside each case.
- After cases have been leveled and joined, and all drain piping, electrical and refrigeration work has been completed then install the kickplate as shown Fig. 6

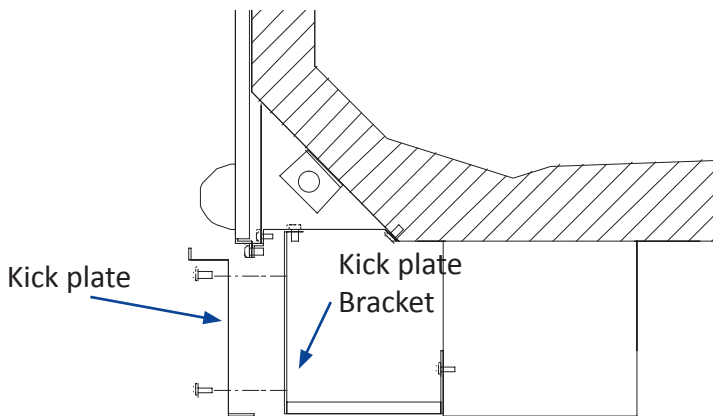

Fig 6. Kickplate Installation

#9~#12 Bolts Specification  
(with T strips)  
#10-24\*1/2" Slit Truss HD Screw  
#10-24, Nut Slit Truss HD Shoulder

## WARNING

- Refrigeration lines are under pressure and should be depressurized before attempting to make any connections.
- Always wear safety glasses and protective gloves when working with refrigerants.  
Contact with refrigerant may cause injury.  
Disconnect pipes with extreme caution. All pipes may contain liquid refrigerant under high pressure.
- Avoid breathing refrigerant and lubrication vapor or mist. Exposure may irritate eyes, nose and throat.  
If accidental system discharge occurs, ventilate work area before resuming service.
- Be sure that any room where you are working is thoroughly ventilated, especially if a leak is suspected.  
Refrigerant vapor is hazardous to your health and can cause death.

## REFRIGERANT PIPING

- Standard piping penetration is located at the front-right area of the case, consisting of a pre-cut access punch-out. (Fig. 7)
- After connections have been made, seal this outlet thoroughly. Seal both the inside and the outside.  
We recommend using an expanding polyurethane foam insulation. Cover foam with silicone to prevent water from entering foam.
- Oil Traps must be installed at the base of all suction line vertical risers.
- Pressure drop can rob the system of capacity. To keep the pressure drop to a minimum, keep the refrigerant line run as short as possible using a minimum number of elbows.
- Optional piping penetrations are rear and top side.

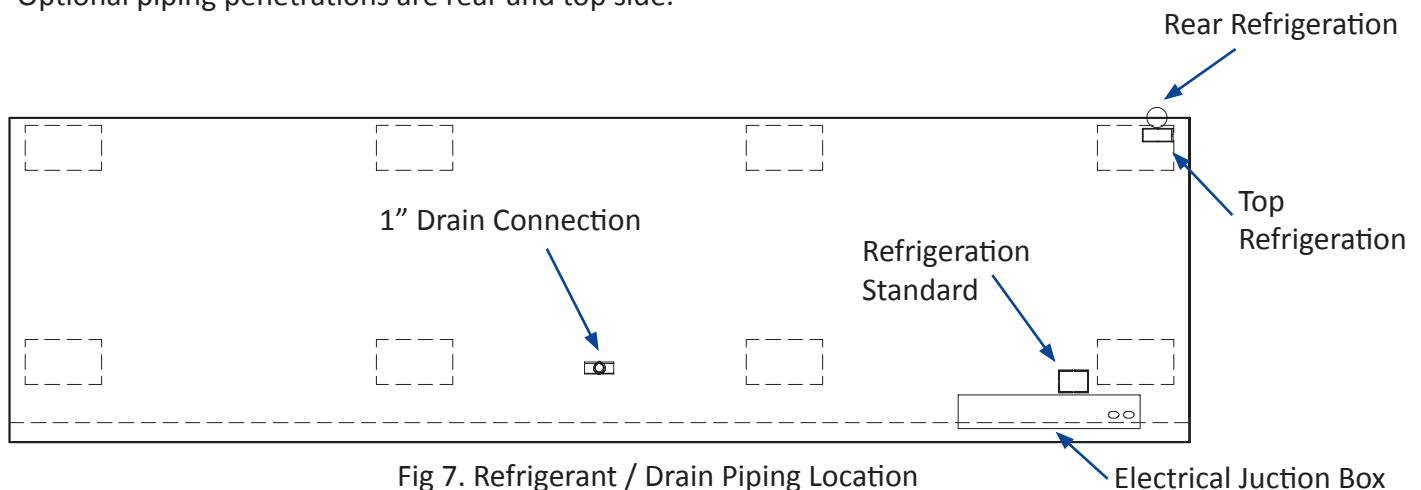

## REFRIGERATION THERMOSTAT

- When the optional refrigeration thermostat is installed, the optional refrigeration thermostat is located toward the right end of the case in the electrical junction box. The sensing bulb is located approximately 20 in. above the coil and 2 ft from the right-hand end (facing front) of the case.
- It can be wired in series with the low-pressure control. It can also be used in a pump down system by wiring it in series with the liquid solenoid valve.

# REFRIGERATION

## ELECTRIC DEFROST

- Periodic defrosting to keep the coil free of frost is accomplished automatically by a time clock used in conjunction with an electric defrost. Temperature termination of defrost is installed for best results. (Table 1)

Frequency	Fail-Safe Time	Termination Temp.	Safety Temp.
24 Hours	45 Minutes	50 °F	85 °F

Table 1. Defrost Data

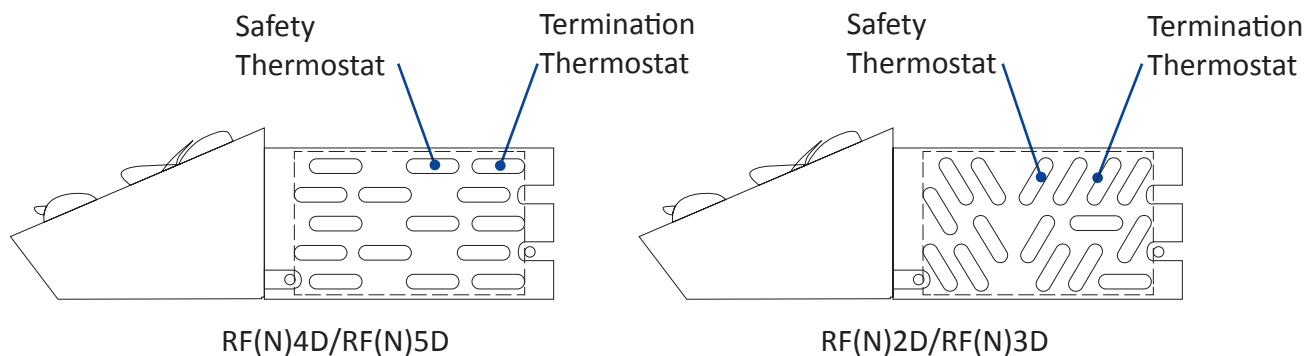

Fig 8. Defrost Thermostat Location

- Temperature termination based on coil temperature allows the length of defrost to vary depending on how much frost is on the coil and the defrost heater voltage.
- Coil frost is a function of shopping patterns, stocking habits, general door maintenance and ambient temperature and humidity. More frost requires a longer defrost. A lower defrost heater voltage extends the defrost period.
- Drip time is not required because Texaking provides a built-in fan delay thermostat.

## PLUMBING

- The drain outlet is located in the front-center of the case. (Fig. 7)
- The U trap, furnished with the case, is constructed of schedule 40 PVC pipe. Please ensure that all connections are water-tight and sealed with the appropriate PVC or ABS cement. Never use drain piping smaller than the nominal diameter of the pipe.
- The drain lines can be run left or right of the tee with the proper pitch to satisfy local drainage requirements.
- To prevent drain pipes from freezing, do not install drain pipes in contact with uninsulated suction lines.



## FIELD WIRING

- Field wiring must be sized for component amperes stamped on the data label in left top inside of case.
- Electrical hookups are made to a junction box located at the bottom-front-right of the case. (Fig. 7)
- All wiring must be in compliance with NEC and local codes.

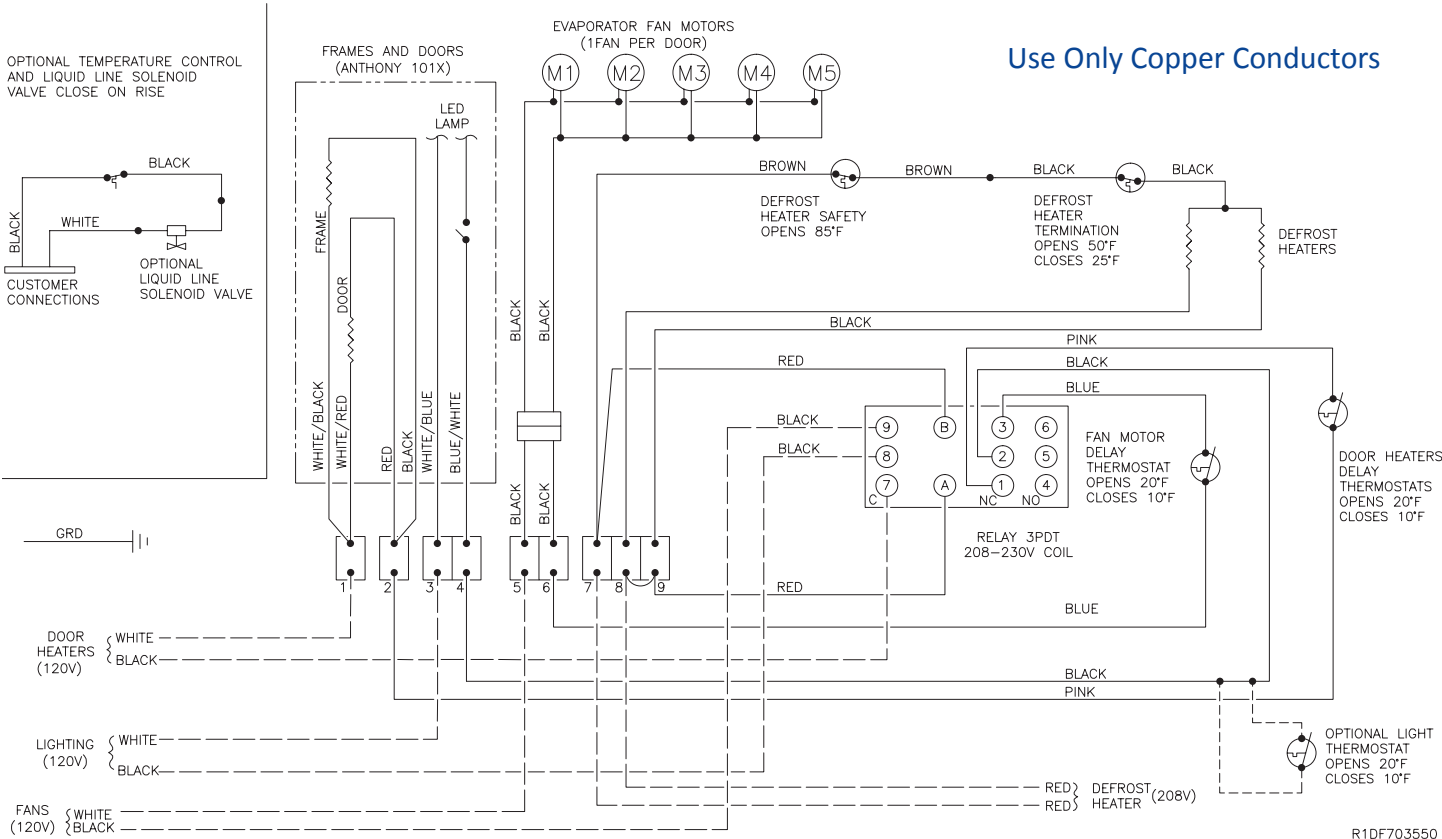

Fig 9. Wiring Diagram

# OPERATION

## SHELF

- The shelves are individually mounted in 1 in. increments on upright and tabs must be seated firmly into position in the uprights before loading shelves.
- The shelves are designed to support the maximum weight load limits as indicated Table 2. Exceeding these maximum weight load limits may cause damage to the shelf, case, store products, and potentially create a hazardous condition for customers and staff.

Nominal Shelf Depth	Maximum Load Limit
20 in.	200 lb
22 in.	200 lb
24 in.	250 lb
27 in.	250 lb

Table 2. Weight Limits for Shelving (Flat position)

## LOAD LIMIT

- Product should not be placed in cases until merchandiser is at proper operating temperature.
- Air discharge and return grille must remain open and free of obstruction at all time to provide proper refrigeration and air curtain performance.
- Do not stock shelves above load limit decals so that it impinges on the air flow pattern.
- Overloading will cause malfunction and the loss of proper temperature levels, particularly when discharge and return air sections are covered.
- Please keep products within the load limit line shown Fig. 10

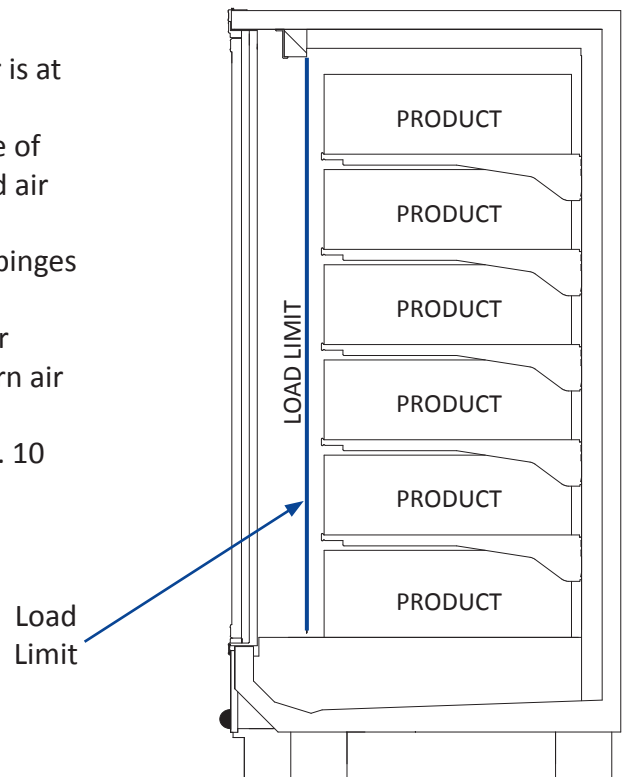

Fig. 10 Load Limit

## WARNING

When cleaning cases the following must be performed prior to cleaning

- To avoid electrical shock, be sure all electric power is turned off before cleaning.
- Do not spray cleaning solution or water directly on fan motors or any electrical connections.
- All lighting components must be dried off prior to insertion and re-energizing the lighting circuit.

## CASE CLEANING

### EXTERIOR SURFACES

- The exterior surfaces must be cleaned with a mild detergent and warm water to protect and maintain their finish. Do not use abrasive cleansers and scouring pads.
- Remove kickplate and clean underneath the case with a broom and a mop. Use warm water and a disinfecting cleaning solution when cleaning underneath the cases.

### INTERIOR SURFACES

- First turn off refrigeration, then disconnect electrical power
- Remove the product and all loose debris to avoid clogging the waste outlet.
- To maintain product integrity, move all product to a cooler until the unit has returned to normal operating temperatures.
- The interior surfaces may be cleaned with most domestic detergents and sanitizing solutions with no harm to the surface.
- Do not use steam or high water pressure hoses to wash the interior. These will destroy the case sealing, causing leaks and poor performance.
- Allow cases to dry before resuming operation
- To clean the LED lamps, shut off the lights in the case, then wipe the lamps down with a soft, damp cloth. Avoid using harsh or abrasive cleaners as they may damage the lights. Be certain that the lamps are completely dry before re-energizing.

### FAN PLENUM

After cleaning be sure the plenum is properly lowered into position.

### COILS

Never use sharp objects around coils. Use a soft brush or vacuum brush to Clean debris from coils.

Contact an authorized Service technician if a coil is punctured, Cracked, or otherwise damaged. Ice in or on the coil indicates the refrigeration and defrost cycle is not operating properly.

Contact an authorized service technician to determine the cause of icing, and to make adjustments as necessary.

### HONEYCOMB

Honeycombs should be cleaned every six months. Dirty honeycombs will cases to perform poorly. The

honeycombs may be cleaned with a vacuum cleaner. Soap and water may be used if all water is removed from the honeycomb cells before replacing.

## Electrical Data

		2 door	3 door	4 door	5 door
Fans (120V)	Fans per Case	2	3	4	5
	Amps	0.6	0.9	1.2	1.5
	Watts	40	60	80	100

## Lighting Data (120V)

LED Lighting		2 door	3 door	4 door	5 door
Anthony OptiMax Pro	Amps	0.30	0.45	0.60	0.75
	Watts	36	54	72	90

## Refrigeration Data

	Frozen Food		Ice Cream	
Evaporator (°F)	-7		-15	
Discharge Air (°F)	-3		3~5	
Superheat Set point at Bulb (°F)	Parallel	Conventional	Parallel	Conventional
BTU/door	960	1000	1040	1080

## Defrost Data (208V)

		2 door	3 door	4 door	5 door
Defrost Heaters (208V)	Amps	6.6	9.8	12.8	19.8
	Watts				
Electric	Frequency (Hr)	24			
	Fail-Safe (min)	45			

## Anti Condensate Heater Data (120V)

		2 door	3 door	4 door	5 door
Anthony 101 (Standard-Energy Doors)	Amps	3.8	5.6	7.4	9.16
	Watts	456	672	888	1099

## CASE DIMENSIONS

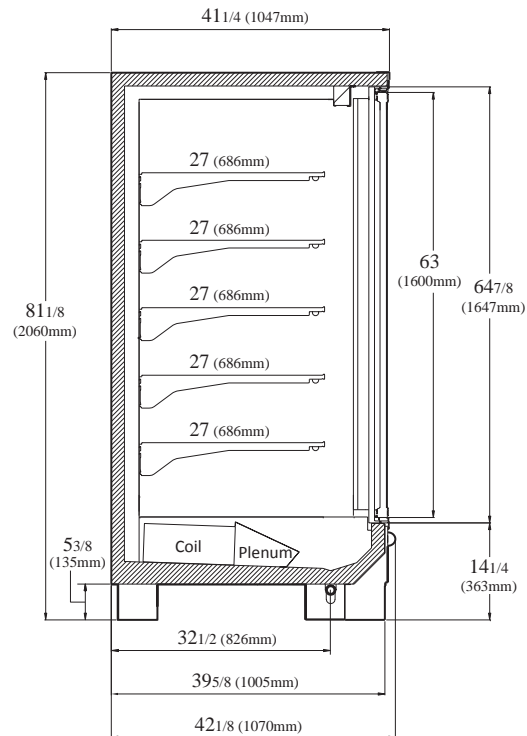

**SIDE VIEW**

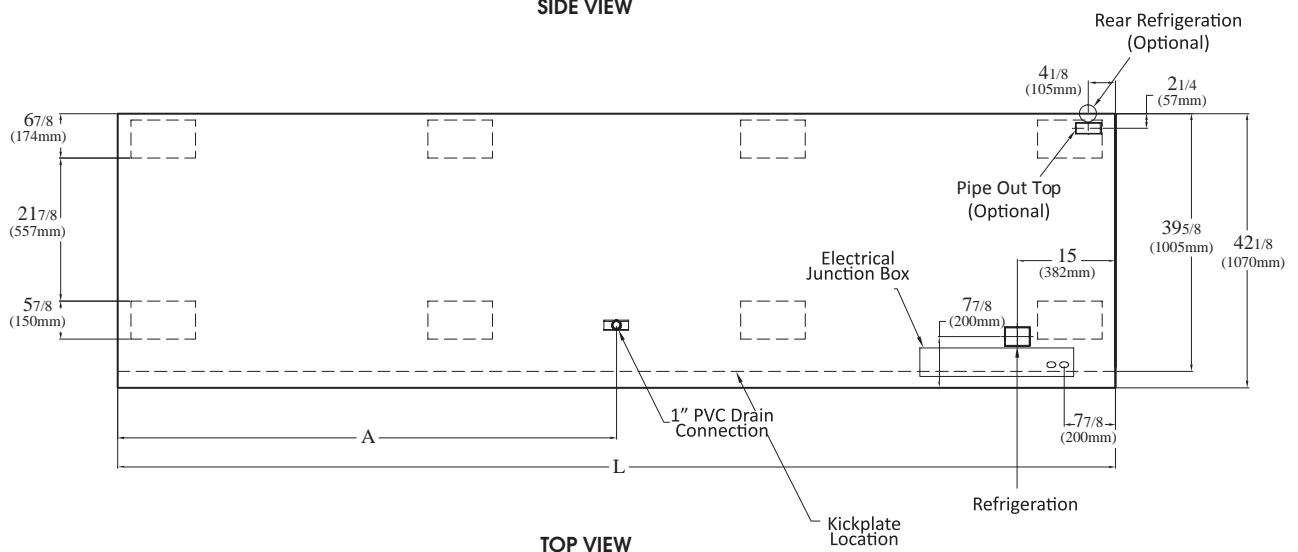

**TOP VIEW**

### PHYSICAL DATA

Case	L	A
2 Door	62-1/16" (1575)	31" (787)
3 Door	92-1/2" (2348)	54-1/8" (1374)
4 Door	122-15/16" (3121)	69-3/8" (1760)
5 Door	153-7/16" (3894)	84-9/16" (2147)

Drain Pipe (in)	1
Liquid Line (in)	3/8
Suction Line (in)	7/8

Design and specifications subject to change without notice.

## CASE DIMENSIONS

(unit : inch)

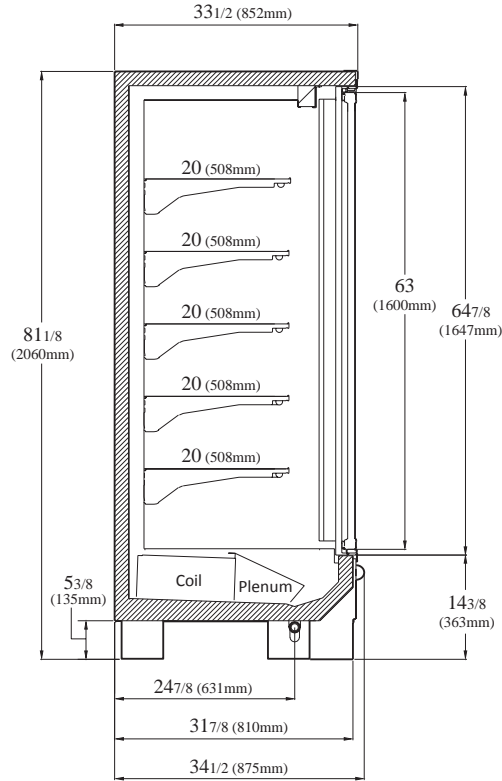

**SIDE VIEW**

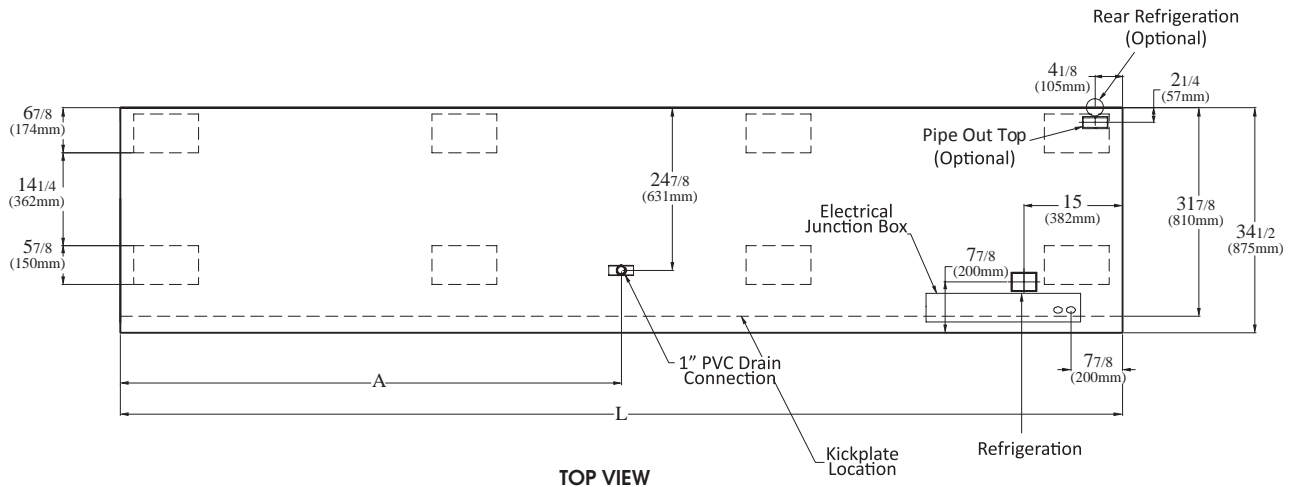

**TOP VIEW**

### PHYSICAL DATA

Case	L	A
2 Door	62-1/16" (1575)	31" (787)
3 Door	92-1/2" (2348)	54-1/8" (1374)
4 Door	122-15/16" (3121)	69-3/8" (1760)
5 Door	153-7/16" (3894)	84-9/16" (2147)

Drain Pipe (in)	1
Liquid Line (in)	3/8
Suction Line (in)	7/8

Design and specifications subject to change without notice.

## LIMITED WARRANTY

Texaking warrants to the original purchaser of every new cases to be free from defects in material and workmanship under normal use and maintenance for a period of fourteen months from the date of original installation or seventeen months after shipment date from Texaking, whichever occurs first.

Any parts covered by this warrant that are examined and determined by Texaking to have been defective within fourteen months from the date of original installation or seventeen months after shipment date from Texaking, whichever occurs first, shall be repaired or replaced as stated below.

Texaking shall be deemed to have fully complied with its obligation under the foregoing warranties by electing either one of the following procedures, at the sole discretion of Texaking.

1. Furnishing a replacement part, freight collect, in even exchange for the returned part, freight collect.
2. Receiving the defective part, freight collect; repairing it: and returning it, freight collect

## WHAT IS NOT COVERED BY THIS WARRANTY

1. To any unit or any part thereof which has been subject to accident, alteration, negligence, misuse or abuse, operation on improper voltage, or which has not been operated in accordance with the Manufacturer's recommendation, or if the serial number of the unit has been altered, defaced, or removed.
2. When the unit, or any part thereof, is damaged by fire, flood, or other act of god.
3. To labor cost for replacement of parts, or for freight, shipping expenses, sales tax or upgrading.
4. When the operation is impaired due to improper installation.
5. When installation and startup forms are not properly complete or returned within two weeks after startup.
6. Outside the continental united states.

This plan does not cover consequential damages. Manufacturer shall not be liable under any circumstances for any consequential damages, including loss of profit, additional labor cost, loss of refrigerant or food products, or injury to personnel or property caused by defective material or parts or for any delay in its performance hereunder due to causes beyond its control. The foregoing shall constitute the sole and exclusive remedy of any purchases and the sole and exclusive liability of manufacturer in connection with this product.

All claims should include: Model number, the serial number of case, proof of purchase, date of installation and all pertinent information supporting the existence of the alleged defect. Any action or breach of these warranty provisions must be commenced within one year after the cause of action has accused.

## MAIL CLAIM TO:

Texaking  
1800 s. Great SW Pkwy.,  
Grand Prairie, TX 75051  
Tel: 214-723-7200 / Fax : 214-723-7215  
[www.turboairinc.com](http://www.turboairinc.com)



# TexKing

1800 S. Great SW Pkwy, Grand Prairie, TX 75051

Tel : 214-723-7200 / Fax : 214-723-7215

[www.turboairinc.com](http://www.turboairinc.com)