

MAC Quantum Wash™

USER GUIDE



User Documentation update information

Any important changes in the MAC Quantum Wash User Guide are listed below.

Revision A

First version released. Covers MAC Quantum Wash firmware version 1.1.0.

© 2013-2014 Martin Professional ApS. Information subject to change without notice. Martin Professional and all affiliated companies disclaim liability for any injury, damage, direct or indirect loss, consequential or economic loss or any other loss occasioned by the use of, inability to use or reliance on the information contained in this document. The Martin logo, the Martin name, the Harman name and all other trademarks in this document pertaining to services or products by Martin Professional or its affiliates and subsidiaries are trademarks owned or licensed by Martin Professional or its affiliates or subsidiaries.

P/N 35000277, Rev. A

Contents

Introduction	4
Effects	5
Beam zones	5
Color control	5
Beam Twister	5
Color temperature control	5
Electronic shutter and strobe effects	5
Dimming	5
Zoom	6
Pan and tilt	6
Control panel operations	7
DMX address	8
DMX modes	9
Fixture ID	9
Personality	9
Factory defaults	10
Custom settings	10
Fixture information readouts	11
DMX signal monitoring	11
Test sequences	11
Manual control	11
Adjusting settings via DMX	12
Resetting	12
Illuminating the display	12
Control menu setting overrides	12
Changing calibration offsets using DMX	12
RDM	14
RDM ID	14
RDM communication	14
Software service functions	15
Service utilities	15
Calibration	15
Firmware installation	15
DMX protocol	17
16-bit Basic Mode	17
16-bit Extended Mode	20
Color temperature control data	26
Control panel menus	27
Service and display messages	30
Warning messages	30
Error messages	31

Introduction



Warning! Before using the MAC Quantum Wash™, read the latest version of the product's Safety and Installation Manual, paying particular attention to the Safety Precautions section.

This User Guide is a supplement to the Installation and Safety Manual that is supplied with the MAC Quantum Wash. Both these documents are available for download from the Martin™ website at www.martin.com. This User Guide contains information that is mainly of interest for lighting designers and operators, whereas the Safety and Installation Manual contains important information for all users, especially installers and technicians.

We recommend that you check the Martin™ website regularly for updated documentation, because we publish revised versions each time we can improve the quality of the information we provide and each time we release new firmware with changes or new features. Each time we revise this guide, we list any important changes on page 2 so that you can keep track of updates.

Effects

This section gives details of the effects that can be controlled via DMX. See the DMX protocol tables starting on page 17 for details of the channels used to control them.

Where fine control is available, the main control channel sets the first 8 bits (the most significant byte or MSB), and the fine channel sets the second 8 bits (the least significant byte or LSB) of the 16-bit control byte. In other words, the fine channel works within the position set by the coarse channel.

Beam zones

The LED array in the MAC Quantum Wash can be controlled in three beam zones plus the Aura:

- Center spot
- Middle ring
- Outer ring
- Aura (backlight effect)

Zones can be controlled together in various combinations or independently.

Color control

The MAC Quantum Wash provides RGB color mixing. In 16-bit Extended mode, color mixing is available for each of the beam zones independently.

White LEDs are not controlled separately but are deployed automatically as required during RGB color mixing.

The 'color wheel effect' channel offers a range of single-color presets which control the fixture's beam zones together, plus a range of split-color presets in which center, middle and outer rings display different colors to give multicolored beam and projection effects.

Beam Twister

The MAC Quantum Wash uses a rotating lens array over the outer ring of LEDs to provide 'Beam Twister' effects. Combining use of the rotating lens array, the zoom system and the fixture's different beam zones gives complex and dynamic multicolored mid-air beam, projection and front glass effects.

In 16-bit Extended mode, you can set the Beam Twister effect to an indexed angle or rotate it with variable speed in either direction. You can also select from a range of pre-programmed Beam Twister effects that combine lens rotation, zoom and multicolored beam zones.

Color temperature control

The MAC Quantum Wash provides white output with CTC (color temperature control) that is controllable from 2000 K to 10 000 K in precise 50 K increments.

Electronic shutter and strobe effects

Electronic shutter/strobe effects include instant blackout and snap open as well as a regular or random strobe with variable speed from 1 Hz to 20 Hz.

Dimming

16-bit resolution overall dimming is available in both 16-bit Basic and 16-bit Extended Modes.

Zoom

The zoom system lets you vary the beam angle to allow wide or tight washlight and mid-air beam effects. The zoom adds visual impact to beam effects when combined with the Beam Twister.

Pan and tilt

8-bit and 16-bit pan and tilt control are available in both 16-bit Basic and 16-bit Extended modes.

Control panel operations

You can configure individual fixture settings (such as the MAC Quantum Wash's DMX address), read out data, execute service operations and view error messages using the fixture's backlit graphic display and control panel.

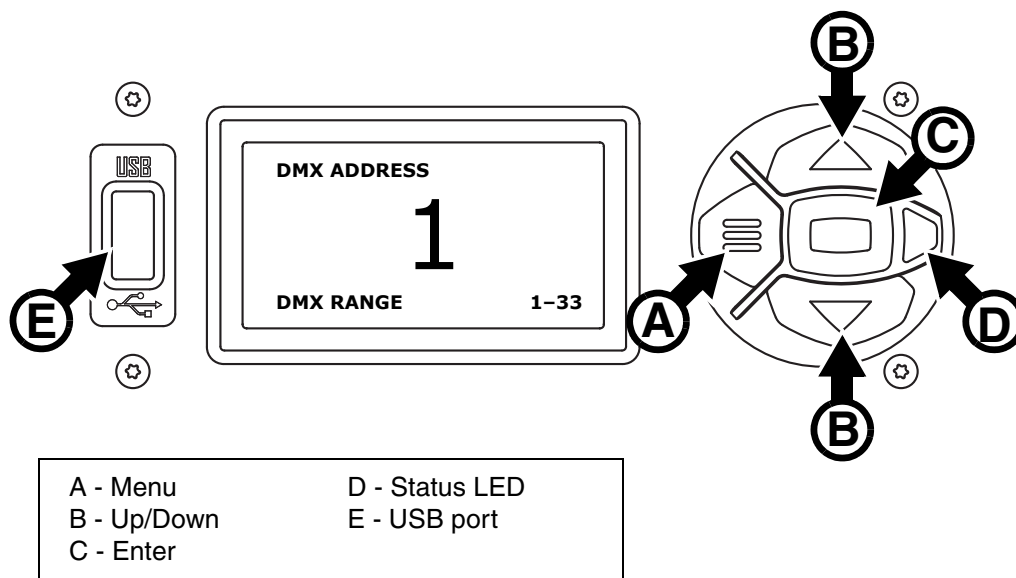

Figure 1: Display and control panel

When the MAC Quantum Wash is powered on, it first boots and resets, then it displays its DMX address (or its fixture ID number, if one has been set) and any status messages (see page 30) in the display **A**.

The display can be set to automatically rotate to match standing or hanging fixture orientation in the **PERSONALITY** → **DISPLAY** menu or the Shortcuts menu (see "Shortcuts" on page 8).

Using the control panel

- Press the Menu button **A** or Enter button **C** to access the menus.
- Use the Up and Down buttons **B** to scroll up and down menus.
- Press the Enter button **C** to enter a menu or make a selection.
- The currently selected item in a menu is indicated by a star ✱.
- Press the Menu button **A** to step backwards through the menus.

Status LED

The LED **D** next to the control buttons indicates fixture status depending on the color displayed and DMX status depending on whether the LED flashes or lights constantly:

- **GREEN**: All parameters normal.
- **AMBER**: Warning (service interval exceeded, for example).
If **ERROR MODE** is set to **Normal**, the warning message will be shown in the display. If **ERROR MODE** is set to **Silent**, the display must be activated by pressing the Enter button C to display the warning message.
- **RED**: Error detected.
If **ERROR MODE** is set to **Normal**, the error message will be shown in the display. If **ERROR MODE** is set to **Silent**, display the error message BY GOING TO NORMAL OR SERVICE - ERROR LIST.
- **FLASHING**: No DMX signal detected.
- **CONSTANT**: Valid DMX signal detected.

Battery power

The MAC Quantum Wash's onboard battery gives access to the most important functions in the control panel when the fixture is not connected to AC power. The following functions are available on battery power:

- DMX address
- DMX control mode (Basic/Extended)
- Fixture ID
- All personality settings (pan/tilt and pan/tilt limit, linked zoom/focus, cooling, fan clean mode, dimming curve, DMX reset, parameter shortcuts, all display settings, error mode)
- Default settings
- Information (Power On Hours and Power Cycles counters, Software version)
- Error list

To activate the display when the fixture is not connected to power, press the Menu button **A**. Press again to enter the menus. The display extinguishes after 10 seconds with no user input and the control panel is de-activated after 1 minute with no user input. Press the Menu button **A** again to re-activate.

Shortcuts

If you hold the Menu button **A** pressed in for 2 - 3 seconds, a shortcut menu with the most important commands appears. Select a command with the Up and Down buttons **B** and press the Enter button **C** to activate, or press the Menu button again to cancel.

- **RESET ALL** resets the whole fixture
- **ROTATE DISPLAY** rotates the MAC Quantum Wash display 180°.

Settings stored permanently

The following settings are stored permanently in the fixture memory and are not affected by powering the MAC Quantum Wash off and on or by updating the fixture software:

- DMX address
- DMX control mode (Basic/Extended)
- Fixture ID
- All personality settings (pan/tilt and pan/tilt limit, linked zoom/focus, cooling, fan clean mode, dimming curve, DMX reset, parameter shortcuts, all display settings, error mode)
- Resettable counters
- Service settings (calibration, firmware)

These settings can be returned to factory defaults using the control menus or via DMX.

Service mode

Holding the Menu and Enter buttons **A** and **C** both pressed in while powering the fixture on puts the fixture into service mode, in which pan and tilt are disabled and a **SERV** warning appears in the display. Service mode removes the risk of unexpected head movement during lamp adjustment. Cycling power and allowing the fixture to start normally takes it out of service mode.

DMX address

The DMX address, also known as the start channel, is the first channel used to receive instructions from the controller. For independent control, each fixture must be assigned its own control channels. If you give two MAC Quantum Wash fixtures the same address, they will behave identically. Address sharing can be useful for diagnostic purposes and symmetrical control, particularly when combined with the inverse pan and tilt options.

DMX addressing is limited to make it impossible to set the DMX address so high that you are left without enough control channels for the fixture.

To set the fixture's DMX address:

1. Press Enter to open the main menu.
2. Press Enter to enter the **DMX ADDRESS** menu, then scroll to the desired address and press Enter to save.
3. Press Menu to exit.

DMX modes

The **CONTROL MODE** menu lets you set the MAC Quantum Wash to one of the two DMX operating modes, basic 16-bit and extended 16-bit:

- Basic 16-bit mode offers coarse control of all effects plus fine control of dimmer, pan and tilt.
- Extended 16-bit mode provides all the features of basic 16-bit mode plus control of the Beam Twister effect and independent control of the different beam zones Outer, Middle, Center and Aura.

The MAC Quantum Wash uses 14 DMX channels in basic 16-bit mode and 33 DMX channels in extended 16-bit mode.

To set the fixture's DMX mode:

1. Press Enter to enter the main menu.
2. Scroll to **CONTROL MODE**, then press Enter. Scroll to select either **BASIC** or **EXTENDED**, then press Enter to save.
3. Press Menu to exit.

Fixture ID

The MAC Quantum Wash lets you set a four-digit ID number to ease identification of the fixtures in an installation. When a fixture is powered on for the first time, it displays its DMX address by default. As soon as you set an ID number other than **0** in **FIXTURE ID**, the MAC Quantum Wash will display this ID number by default, and indicate **FIXTURE ID** in the display.

Personality

The MAC Quantum Wash provides several options that let you optimize the fixture for different applications in the **PERSONALITY** menu:

- The **PAN/TILT** menu lets you swap and/or invert pan and tilt.
- The **SPEED** menu lets you set **PAN/TILT** to **NORMAL**, **FAST** (optimized for speed) or **SLOW** (optimized for smooth movement – useful for slow movements in long-throw applications). Likewise, you can select an overall speed for all the effects by setting **EFFECT** speed to **NORMAL**, **FAST** or **SLOW**. You can also set effect speed to **FOLLOW P/T**, in which effects will always use whatever speed is set for pan and tilt.
- **DIMMER CURVE** provides four dimming options (see Figure 2):

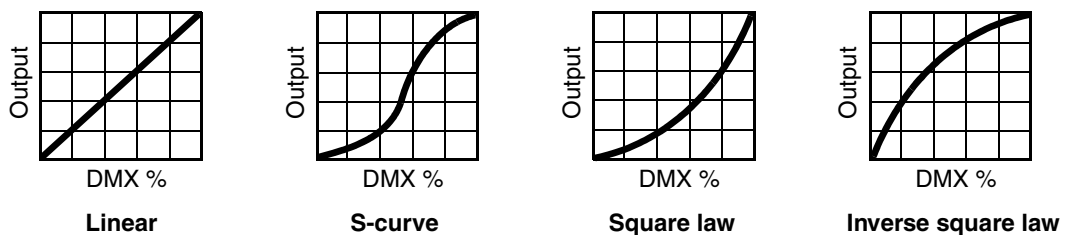

Figure 2: Dimming curve options

- **LINEAR** – (optically linear) the increase in light intensity appears to be linear as DMX value is increased.
- **S-CURVE** – light intensity control is finer at low levels and high levels and coarser at medium levels. This curve emulates the RMS voltage dimming characteristics of an incandescent lamp such as the tungsten halogen lamp of the Martin™ MAC TW1™.
- **SQUARE LAW** – light intensity control is finer at low levels and coarser at high levels.
- **INV SQUARE LAW** – light intensity control is coarser at low levels and finer at high levels.
- **COLOR MODE** offers two options that affect color saturation and evenness between fixtures:
 - **Extended Color** mode optimizes LED deployment for color saturation and gets the deepest color saturation possible from the LEDs. The white color point is calibrated and even across different fixtures, but as the fixture approaches full color saturation there can be very small differences in color rendition between different fixtures.

- **Calibrated Color** mode (called **Common Color** mode in fixture software v.1.1.0) optimizes LED deployment for even color rendition between fixtures. All fixtures display identical color from white point to full color saturation, and maximum color saturation levels are limited slightly to ensure this.
- **VIDEO TRACKING** optimizes performance if the MAC Quantum Wash is used with a video source. In normal use, the fixture processes the DMX signal it receives, tracking (or smoothing out) changes in values in order to ensure smooth fading between colors and/or intensities. This signal processing takes fractions of a second and is normally invisible, but if the fixture is used to display video (using Martin P3™ video system components to convert video to DMX, for example) the processing can interfere with video response times. If you enable video tracking, the fixture does not 'smooth out' DMX input but instead snaps instantly when a DMX value changes.
For best results, we recommend that you enable video tracking during video display and disable it (the default setting) during normal DMX control.
- **DMX RESET** defines whether the fixture or individual effects can be reset by sending a DMX command on the fixture settings channel. Setting it to OFF can help you avoid accidentally sending a Reset command during a show, for example.
- **EFFECT SHORTCUT** determines whether the effects take the shortest path between two positions (shortcuts enabled) or not (shortcuts disabled). If shortcuts are enabled, the virtual color wheel effect can go through a virtual open position during changes from one color to another just as a mechanical color wheel would.
- **COOLING MODE** lets you select between two cooling fan options depending on whether your priority is highest light output or quietest cooling fan operation:
 - **REGULATE FANS** optimizes cooling fan operation for light output. It controls fixture temperature by varying cooling fan speed up to the maximum speed available and does not limit light intensity.
 - **REGULATE INTENSITY** optimizes cooling fan operation for quietness. It limits cooling fan speed to a level that causes minimal noise and controls fixture temperature by limiting light intensity when necessary.
- **DISPLAY** offers the following options for the LCD display:
 - **DISPLAY SLEEP** determines whether the display remains on permanently, or goes into sleep mode 2, 5 or 10 minutes after the last time a control panel button is pressed.
 - **DISPLAY INTENSITY** lets you define the brightness of the display backlighting. Select **Auto** for automatic adjustment to match the ambient light level, or manually set the intensity to a level from 0% to 100%.
 - **DISPLAY ROTATION** lets you rotate the display manually through 180° so that it can be read easily no matter how the fixture is oriented. If set to **Auto**, the MAC Quantum Wash senses its orientation and rotates the display automatically.
 - **DISPLAY CONTRAST** lets you define the contrast of the backlit graphic display. Select **Auto** for automatic adjustment to match display intensity, or manually set the contrast to a level from 0% to 100%.
- **ERROR MODE** enables or disables error warnings. If set to **NORMAL**, the display is activated and lights up if the fixture needs to report an error. If set to **SILENT**, the fixture does not light the display with error warnings but error messages can still be read when the display is activated manually. In both **NORMAL** and **SILENT** modes, the status LED lights amber to indicate a warning and red to indicate an error.

Factory defaults

FACTORY DEFAULT lets you reload the fixture's factory default settings. Effect calibration settings are not affected, so any changes you have made to zoom, pan and tilt offsets will be kept.

Custom settings

The custom configuration function CUSTOM 1 - CUSTOM 3 allows you to save and recall up to three sets of fixture settings. The savable settings comprise:

- all the settings in the PERSONALITY menu,
- the fixture's DMX address, and
- the fixture's DMX control mode: Extended 16-bit or Basic 16-bit mode.

Fixture information readouts

The following fixture information can be called up in the display:

- **POWER ON TIME** provides two counters:
 - The **TOTAL** counter is not user-resettable and displays total hours powered on since manufacture.
 - The **RESETTABLE** counter is user-resettable and displays the number of hours the fixture has been powered on since the counter was last reset.
- **POWER ON CYCLES** also provides two counters:
 - The **TOTAL** counter is not user-resettable and displays the total number of power on/off cycles since manufacture.
 - The **RESETTABLE** counter is user-resettable and displays the number of power on/off cycles since the counter was last reset.
- **SW VERSION** displays the currently installed firmware (fixture software) version.
- **RDM UID** displays the fixture's factory-set unique ID for identification in RDM systems.
- **FAN SPEEDS** provides separate status readouts from the fixture's cooling fans.
- **TEMPERATURES** provides separate PCB temperature readouts.

DMX signal monitoring

The MAC Quantum Wash provides data on the DMX signal it is receiving in the **DMX LIVE** menu. This information can be useful for troubleshooting control problems.

RATE displays the DMX refresh rate in packets per second. Values lower than 10 or higher than 44 may result in erratic performance, especially when using tracking control.

QUALITY displays the quality of the received DMX data as a percentage of packets received. Values much below 100 indicate interference, poor connections, or other problems with the serial data link that are the most common cause of control problems.

START CODE displays the DMX start code. Packets with a start code other than 0 may cause irregular performance.

The remaining options under **DMX LIVE** display the DMX values in a range from 0 - 255 that are being received on each channel. The DMX channels displayed depend on whether the fixture is in 16-bit or 16-bit extended mode.

Test sequences

TEST activates effects in sequence, allowing you to test all effects, pan and tilt movement only, or effects only (i.e. without pan and tilt movement) without a DMX controller:

- Select a test type and press Enter to start the test.
- Press Menu to stop the test.

Manual control

The **MANUAL CONTROL** menu lets you reset the MAC Quantum Wash and operate the fixture without a DMX controller. To execute commands in the **MANUAL CONTROL** menu, select a menu item for the effect that you want to control, then enter a value from 0 to 255 to apply a command. The menu items and values correspond to the commands listed in the DMX protocol on page 17.

Adjusting settings via DMX

Certain fixture settings and parameters can be adjusted from the DMX controller on the Fixture control/settings channel.

Commands sent on the fixture control channel override any settings entered in the fixture's onboard control menus.

To help you avoid accidentally applying a setting that may disrupt a light show, for example, most of the commands must be held for a certain time before they are applied. For example, the command that turns off the display illumination must be held for one second to activate it. The command that resets the fixture must be held for five seconds to activate it. The times required to apply DMX commands on the Fixture control/settings channel are listed for each command on page 19 in the DMX protocol.

Resetting

Either the entire fixture or individual effects can be reset to their initial positions. Resetting individual effects can allow on-the-fly recovery if an effect loses its correct position, for example, without having to reset the entire fixture.

Illuminating the display

The fixture's display panel can be brought out of sleep mode with a DMX command. This makes it possible to read the fixture's DMX address while the fixture is installed in the rig.

After being illuminated in this way, the display will return to sleep mode according to the setting entered in the onboard control menus.

Control menu setting overrides

The following fixture settings can be adjusted via DMX, overriding the settings entered in the onboard control menus. See under "Control panel menus" on page 27 for details of these settings.

- Dimming curve
- Pan and tilt speed
- Parameter shortcuts (beam twister shortcuts)
- Video tracking
- Color mode
- Fan speed
- Pan/tilt and zoom calibration offsets

Changing calibration offsets using DMX

The Fixture control/settings DMX channel allows pan, tilt and zoom to be calibrated by changing their factory default offsets IN PERCENT from the DMX controller.

To set an effect offset:

1. Set the effect you want to calibrate to a specific value via DMX (for example, set all the fixtures in a group to DMX value 200 on the zoom channel).
2. Select 'Enable calibration' on the Fixture control/settings channel and hold for 5 seconds to activate.
3. The DMX control channels for pan, tilt and zoom now adjust the calibration offsets for those effects. Adjust each offset until the effect is in the required position (for example, adjust the zoom offset on each fixture in the group until the beam angle on all fixtures is identical – this is the position you will obtain when you send DMX value 200).
4. Send a 'Store ...' command for the effect on the Fixture control/settings channel and hold for 5 seconds to activate. Calibration offsets are now stored in memory and normal DMX control is restored.

Calibration offsets that are stored in memory are not affected by powering the fixture off and on or by updating the fixture software.

You can reset all calibration offsets to their default values by sending a DMX value on the Fixture control/settings channel. You must hold the value for 5 seconds. The fixture will return to factory default calibration values. If you have overwritten the factory default values by applying a CALIBRATION → SAVE DEFAULTS command in the SERVICE menu, the fixture will return to the last default calibration values that were saved).

RDM

The MAC Quantum Wash can communicate using RDM (Remote Device Management) in accordance with ESTA's *American National Standard E1.20-2006: Entertainment Technology RDM Remote Device Management Over DMX512 Networks*.

RDM is a bi-directional communications protocol for use in DMX512 control systems, it is the open standard for DMX512 device configuration and status monitoring.

The RDM protocol allows data packets to be inserted into a DMX512 data stream without affecting existing non-RDM equipment. It allows a console or dedicated RDM controller to send commands to and receive messages from specific fixtures.

RDM ID

Each MAC Quantum Wash has a factory-set RDM UID (unique identification number) that makes it addressable and identifiable in RDM systems. The number can be found in the control panel **INFORMATION** menu under **RDM UID**.

RDM communication

The MAC Quantum Wash supports the standard RDM PIDs (Parameter IDs) required by ESTA plus a range of manufacturer-specific PIDs. Sending **SUPPORTED_PARAMETERS** and **PARAMETER_DESCRIPTION** commands from an RDM controller will call up a list of the PIDs supported in the firmware version installed in the fixture.

Software service functions

Service utilities

The control panel **SERVICE** menu provides utilities for technicians rigging or servicing the fixture:

- **ERROR LIST** displays any error messages that are stored in internal memory.
- **FAN CLEAN** lets you set all cooling fans to run at maximum speed for short periods for cleaning purposes.
- **PT FEEDBACK** lets you disable feedback to the fixture software from the pan, tilt and effects positioning systems. If feedback is set to **ON** and a pan, tilt or effect position error is detected, the shutter closes and the effect resets. This feature can be disabled by setting feedback to **OFF**. The **OFF** setting is not saved when the fixture is powered off, and the system will be re-enabled the next time the fixture starts. If a pan/tilt position error occurs and the system cannot correct pan/tilt position within 10 seconds, feedback is automatically disabled.
- **CALIBRATION** lets you set new default positions for calibration purposes, set effects to their factory default positions or overwrite the factory default positions with new values. See "Calibration" below.
- **USB** lets you update the firmware (fixture software) using a USB memory device. For a detailed guide to updating the firmware, see "Installing using a USB memory device" later in this chapter.

Calibration

Martin™ fixtures are adjusted and calibrated at the factory, and further calibration will normally only be necessary if fixtures have been subjected to abnormal shocks during transport, if normal wear and tear has affected alignment after an extended period of use. You can also use calibration to fine-tune fixtures for a particular location or application.

The **CALIBRATION** menu lets you define offsets in the fixture software to adjust the positions of pan, tilt and zoom relative to the DMX values the fixture receives. This allows you to fine-tune fixtures and achieve uniform behavior in different fixtures.

Calibration can be carried out using the fixture's onboard control panel and via DMX (see "Changing calibration offsets using DMX" on page 12).

A recommended procedure is to set pan, tilt and zoom to the same DMX values in multiple fixtures and then calibrate each fixture using its onboard control panel while comparing its light output with a reference fixture. The calibration range available for each effect varies. Calibration values are expressed as percentages. After selecting a value, press Enter to set the effect to that value.

Loading and storing default calibration offsets

In the **SERVICE** → **CALIBRATION** menu, **LOAD DEFAULTS** lets you erase the calibration offsets that you have defined and reload the default calibration offsets that are stored in memory.

SERVICE → **CALIBRATION** → **SAVE DEFAULTS** lets you overwrite the factory default calibration offsets that are stored in memory with any new offsets that you have defined. Overwriting is permanent, so once you have saved new default offsets, **LOAD DEFAULTS** will load the new defaults, not the original factory defaults.

Firmware installation

The currently installed firmware (fixture software) version can be viewed in the control panel **INFORMATION** menu. Firmware updates are available from the Martin™ website and can be installed using a USB memory stick or a Windows PC running the Martin Uploader application and either a Martin Universal USB Duo™ USB-DMX interface device or a Martin DABS1™ USB-DMX interface device.

Calibration data is stored in the relevant modules wherever possible so that a module will stay calibrated if it is removed from the fixture or installed in another fixture.

Do not switch the fixture off during a firmware update, or firmware will be corrupted.

Installing using a USB memory device

Important! *Do not remove a USB memory device while the fixture is updating files.*

The following are required in order to install firmware using a USB memory device:

- The MAC Quantum Wash '.BANK' firmware update file, available for download from the Martin website at <http://www.martin.com>.
- A USB memory stick or other USB memory device with the update file copied from a PC into the USB stick's root directory.

To install the MAC Quantum Wash firmware:

1. Download the '.BANK' firmware file from the MAC Quantum Wash Product Support page at www.martin.com, read the firmware release notes carefully to check for any instructions or warnings, and copy the firmware file to the root directory of a USB stick.
2. Disconnect the data link from the MAC Quantum Wash.
3. Insert the USB stick in the MAC Quantum Wash's USB host socket. The fixture should recognize the USB stick and illuminate the display. If the fixture does not recognize the USB stick, navigate to **SERVICE** → **USB** in the control panel.
4. **AVAILABLE FIRMWARE** will appear in the display. You can now scroll through the firmware versions available.
5. To install a firmware version, select it and press Enter. The MAC Quantum Wash asks you to confirm installation of the new firmware. Press Enter to confirm and press Menu to exit without confirming.
6. Allow the fixture to install the firmware and reboot.
7. Remove the USB stick. The newly-installed firmware version will now be displayed in the **INFORMATION** menu.
8. Reconnect the data link.
9. If you have installed a new firmware version, check the Martin™ website to see whether an updated User Guide is available for this firmware.

Fixture information and settings, including zoom-focus linking, are not affected when new software is uploaded.

Installing using a PC and hardware interface

The following are required in order to install firmware using a PC:

- The MAC Quantum Wash firmware '.MU3' update file, available for download from the Product Support area of the Martin website at <http://www.martin.com>.
- A Windows PC running the latest version of the Martin Uploader™ application (also available for download free of charge from www.martin.com) and loaded with the firmware update file.
- A USB-DMX hardware interface device such as the Martin USB Duo™ or Martin DABS1™.

To install the MAC Quantum Wash firmware:

1. Download the firmware '.MU3' file from the MAC Quantum Wash support page on the Martin website to the PC.
2. Read the firmware release notes carefully to check for any instructions or warnings.
3. Follow the instructions for an auto upload/upload via DMX in the Martin Uploader application help files and supplied with the hardware interface.

DMX protocol

16-bit Basic Mode

Channel	DMX Value	Percent	Function	Fade type	Default value
1	0 - 19	0 - 7	Strobe/shutter effect	Snap	30
	20 - 49	8 - 19	Shutter closed		
	50 - 200	20 - 78	Shutter open		
	201 - 210	79 - 82	Strobe, slow → fast		
	211 - 255	82 - 100	Shutter open		
2	0 - 65535	0 - 100	Dimmer fade (MSB)	Fade	0
			Closed → open	Fade	0
3			Dimmer fade, fine (LSB)	Fade	0
4	0 - 255	0 - 100	Red 0 → 100%	Fade	0
5	0 - 255	0 - 100	Green 0 → 100%	Fade	0
6	0 - 255	0 - 100	Blue 0 → 100%	Fade	0
7	0 - 10	0 - 4	CTC Disabled	Fade	101
	11 - 171	4 - 67	Color temp. from 2000 K to 10 000 K in 50 K steps (see Table 3 on page 26)		
	171 - 255	67 - 100	10 000 K		
8	0 - 10	0 - 4	'Color wheel' color selection effect Open. RGB color mixing enabled	Snap	0
	11 - 12	4 - 5	Color 1 - LEE 790 - Moroccan pink		
	13 - 14	5	Color 2 - LEE 157 - Pink		
	15 - 16	6	Color 3 - LEE 332 - Special rose pink		
	17 - 18	7	Color 4 - LEE 328 - Follies pink		
	19 - 20	7 - 8	Color 5 - LEE 345 - Fuchsia pink		
	21 - 22	8 - 9	Color 6 - LEE 194 - Surprise pink		
	23 - 24	9	Color 7 - LEE 181 - Congo Blue		
	25 - 26	10	Color 8 - LEE 071 - Tokyo Blue		
	27 - 28	11	Color 9 - LEE 120 - Deep Blue		
	29 - 30	11 - 12	Color 10 - LEE 079 - Just Blue		
	31 - 32	12 - 13	Color 11 - LEE 132 - Medium Blue		
	33 - 34	13	Color 12 - LEE 200 - Double CT Blue		
	35 - 36	14	Color 13 - LEE 161 - Slate Blue		
	37 - 38	14 - 15	Color 14 - LEE 201 - Full CT Blue		
	39 - 40	15 - 16	Color 15 - LEE 202 - Half CT Blue		
	41 - 42	16	Color 16 - LEE 117 - Steel Blue		
	43 - 44	17	Color 17 - LEE 353 - Lighter Blue		
	45 - 46	18	Color 18 - LEE 118 - Light Blue		
	47 - 48	18 - 19	Color 19 - LEE 116 - Medium Blue Green		
	49 - 50	19 - 20	Color 20 - LEE 124 - Dark Green		
	51 - 52	20	Color 21 - LEE 139 - Primary Green		
	53 - 54	21	Color 22 - LEE 089 - Moss Green		
	55 - 56	21 - 22	Color 23 - LEE 122 - Fern Green		
	57 - 58	22 - 23	Color 24 - LEE 738 - JAS Green		
	59 - 60	23	Color 25 - LEE 088 - Lime Green		
	61 - 62	24	Color 26 - LEE 100 - Spring Yellow		
	63 - 64	25	Color 27 - LEE 104 - Deep Amber		
	65 - 66	25 - 26	Color 28 - LEE 179 - Chrome Orange		
	67 - 68	26 - 27	Color 29 - LEE 105 - Orange		
	69 - 70	27	Color 30 - LEE 021 - Gold Amber		
	71 - 72	28	Color 31 - LEE 778 - Millennium Gold		
	73 - 74	29	Color 32 - LEE 135 - Deep Golden Amber		
	75 - 76	29 - 30	Color 33 - LEE 164 - Flame Red		
	77 - 78	30	Color 34 - Magenta		
	79 - 80	31	Color 35 - Medium Lavender		
81 - 82	32	Color 36 - White			

Table 1: DMX Protocol - Basic 16-bit mode

Channel	DMX Value	Percent	Function	Fade type	Default value
8 (cont.)	83 - 103	32 - 40	'Color wheel rotation' effect Clockwise, fast → slow	Snap	0
	104 - 106	41	Stop (this will stop wherever the color is at the time)		
	107 - 127	42 - 50	Counter-clockwise, slow → fast		
	128 - 129	50	Split color Color preset 1		
	130 - 131	51	Color preset 2		
	132 - 133	52	Color preset 3		
	134 - 135	52 - 53	Color preset 4		
	136 - 137	53 - 54	Color preset 5		
	138 - 139	54	Color preset 6		
	140 - 141	55	Color preset 7		
	142 - 143	55 - 56	Color preset 8		
	144 - 145	56 - 57	Color preset 9		
	146 - 147	57	Color preset 10		
	148 - 149	58	Color preset 11		
	150 - 151	59	Color preset 12		
	152 - 153	59 - 60	Color preset 13		
	154 - 155	60 - 61	Color preset 14		
	156 - 157	61	Color preset 15		
	158 - 159	62	Color preset 16		
	160 - 161	63	Color preset 17		
	162 - 163	63 - 64	Color preset 18		
	164 - 165	64	Color preset 19		
	166 - 167	65	Color preset 20		
	168 - 169	66	Color preset 21		
	170 - 171	66 - 67	Color preset 22		
	172 - 173	67 - 68	Color preset 23		
	174 - 175	68	Color preset 24		
	176 - 177	69	Color preset 25		
	178 - 179	70	Color preset 26		
	180 - 181	70 - 71	Color preset 27		
	182 - 183	71	Color preset 28		
	184 - 185	72	Color preset 29		
	186 - 187	73	Color preset 30		
	188 - 189	73 - 74	Color preset 31		
	190 - 191	74 - 75	Color preset 32		
	192 - 193	75	Color preset 33		
194 - 195	76	Color preset 34			
196 - 197	77	Color preset 35			
198 - 199	77 - 78	Color preset 36			
200 - 220	78 - 86	'Color wheel rotation' effect Clockwise, fast → slow			
221 - 224	86 - 88	Stop (this will stop wherever the color is at the time)			
225 - 245	88 - 96	Counter-clockwise, slow → fast			
246 - 255	96 - 100	Open			
9	0 - 200 201 - 255	0 - 78 79 - 100	Zoom Flood → spot Overdrive min. → max.	Fade	200
10	0 - 65535	0 - 100	Pan, 16-bit (MSB and LSB) Left → right (32768 = neutral)	Fade	32768
11					
12	0 - 65535	0 - 100	Tilt, 16-bit (MSB and LSB) Up → down (32768 = neutral)	Fade	32768
13					

Table 1: DMX Protocol - Basic 16-bit mode

Channel	DMX Value	Percent	Function	Fade type	Default value
14			Fixture control/settings <i>(hold for number of seconds indicated to activate)</i>		
	0 - 9	0 - 4	<i>No function (disables calibration) – 5 sec.</i>		
	10 - 14	4 - 5	Reset entire fixture – 5 sec.		
	15	6	Reset shutter/dimmer only – 5 sec.		
	16	6	Reset color only – 5 sec.		
	17	7	Reset beam only – 5 sec.		
	18	7	Reset pan and tilt only – 5 sec.		
	19 - 22	7 - 9	<i>No function</i>		
	23	9	Linear dimming curve – 1 sec. <i>(menu override, setting unaffected by power off/on)</i>		
	24	9	Square law dimming curve – 1 sec. <i>(menu override, factory default setting, setting unaffected by power off/on)</i>		
	25	10	Inverse square law dimming curve – 1 sec. <i>(menu override, setting unaffected by power off/on)</i>		
	26	10	S-curve dimming curve – 1 sec. <i>(menu override, setting unaffected by power off/on)</i>		
	27	11	<i>No function</i>		
	28	11	Fast pan and tilt speed – 1 sec. <i>(default setting, menu override - setting returns to MENU setting after power on/off)</i>		
	29	11	Smooth pan and tilt speed – 1 sec. <i>(menu override - setting returns to MENU setting after power on/off)</i>		
	30	12	Parameter shortcuts = ON (default)		
	31	12	Parameter shortcuts = OFF	Snap	0
	32 - 35	13 - 14	<i>No function</i>		
	36	14	Enable video tracking		
	37	14	Disable video tracking		
	38	15	Extended color (default)		
	39	15	Calibrated color		
	40 - 49	16 - 19	<i>No function</i>		
	50	20	Regulated fan speed, fixed intensity (default)		
	51	20	Fixed fan speed, regulated intensity		
	52	20	Turn on control panel display – 1 sec.		
	53	21	Turn off control panel display – 1 sec.		
	54 - 99	21 - 39	<i>No function</i>		
	100	39	Enable calibration – 5 sec.		
	101	39	Store pan and tilt calibration – 5 sec.		
	102	40	Store dimmer calibration – 5 sec.		
	103 - 110	40 - 43	<i>No function</i>		
	111	43	Store Beam Twister calibration – 5 sec.		
	112 - 113	44	<i>No function</i>		
	114	45	Store zoom calibration – 5 sec.		
	115	45	Store pan calibration – 5 sec.		
	116	45	Store tilt calibration – 5 sec.		
	117 - 198	46 - 77	<i>No function</i>		
	199	78	Reset all calibration values to defaults – 5 sec.		
	200 - 255	78 - 100	<i>No function</i>		

Table 1: DMX Protocol - Basic 16-bit mode

MSB = Most significant byte

LSB = Least significant byte

16-bit Extended Mode

Channel	DMX Value	Percent	Function	Fade type	Default value
1	0 - 19	0 - 7	Strobe/shutter effect Shutter closed Shutter open Strobe, slow → fast Shutter open Random strobe, slow → fast	Snap	30
	20 - 49	8 - 19			
	50 - 200	20 - 78			
	201 - 210	79 - 82			
	211 - 255	82 - 100			
2	0 - 65535	0 - 100	Dimmer fade (MSB) Closed → open	Fade	0
			Dimmer fade, fine (LSB)	Fade	0
4	0 - 10	0 - 4	CTC Disabled Color temp. from 2000 K to 10 000 K in 50 K steps (see Table 3 on page 26) 10 000 K	Fade	101
	11 - 171	4 - 67			
	171 - 255	67 - 100			
5	0 - 10	0 - 4	'Color wheel' color selection effect Open. RGB color mixing enabled Color 1 - LEE 790 - Moroccan pink Color 2- LEE 157 - Pink Color 3 - LEE 332 - Special rose pink Color 4 - LEE 328 - Follies pink Color 5 - LEE 345 - Fuchsia pink Color 6 - LEE 194 - Surprise pink Color 7 - LEE 181 - Congo Blue Color 8 - LEE 071 - Tokyo Blue Color 9 - LEE 120 - Deep Blue Color 10 - LEE 079 - Just Blue Color 11 - LEE 132 - Medium Blue Color 12 - LEE 200 - Double CT Blue Color 13 - LEE 161 - Slate Blue Color 14 - LEE 201 - Full CT Blue Color 15 - LEE 202 - Half CT Blue Color 16 - LEE 117 - Steel Blue Color 17 - LEE 353 - Lighter Blue Color 18 - LEE 118 - Light Blue Color 19 - LEE 116 - Medium Blue Green Color 20 - LEE 124 - Dark Green Color 21 - LEE 139 - Primary Green Color 22 - LEE 089 - Moss Green Color 23 - LEE 122 - Fern Green Color 24 - LEE 738 - JAS Green Color 25 - LEE 088 - Lime Green Color 26 - LEE 100 - Spring Yellow Color 27 - LEE 104 - Deep Amber Color 28 - LEE 179 - Chrome Orange Color 29 - LEE 105 - Orange Color 30 - LEE 021 - Gold Amber Color 31 - LEE 778 - Millennium Gold Color 32 - LEE 135 - Deep Golden Amber Color 33 - LEE 164 - Flame Red Color 34 - Magenta Color 35 - Medium Lavender Color 36 - White	Snap	0
	11 - 12	4 - 5			
	13 - 14	5			
	15 - 16	6			
	17 - 18	7			
	19 - 20	7 - 8			
	21 - 22	8 - 9			
	23 - 24	9			
	25 - 26	10			
	27 - 28	11			
	29 - 30	11 - 12			
	31 - 32	12 - 13			
	33 - 34	13			
	35 - 36	14			
	37 - 38	14 - 15			
	39 - 40	15 - 16			
	41 - 42	16			
	43 - 44	17			
	45 - 46	18			
	47 - 48	18 - 19			
	49 - 50	19 - 20			
	51 - 52	20			
	53 - 54	21			
	55 - 56	21 - 22			
	57 - 58	22 - 23			
	59 - 60	23			
	61 - 62	24			
	63 - 64	25			
	65 - 66	25 - 26			
	67 - 68	26 - 27			
	69 - 70	27			
	71 - 72	28			
73 - 74	29				
75 - 76	29 - 30				
77 - 78	30				
79 - 80	31				
81 - 82	32				

Table 2: DMX Protocol - 16-bit Extended Mode

Channel	DMX Value	Percent	Function	Fade type	Default value
5 (cont.)	83 - 103	32 - 40	'Color wheel rotation' effect Clockwise, fast → slow	Snap	0
	104 - 106	41	Stop (this will stop wherever the color is at the time)		
	107 - 127	42 - 50	Counter-clockwise, slow → fast		
	128 - 129	50	Split color Color preset 1		
	130 - 131	51	Color preset 2		
	132 - 133	52	Color preset 3		
	134 - 135	52 - 53	Color preset 4		
	136 - 137	53 - 54	Color preset 5		
	138 - 139	54	Color preset 6		
	140 - 141	55	Color preset 7		
	142 - 143	55 - 56	Color preset 8		
	144 - 145	56 - 57	Color preset 9		
	146 - 147	57	Color preset 10		
	148 - 149	58	Color preset 11		
	150 - 151	59	Color preset 12		
	152 - 153	59 - 60	Color preset 13		
	154 - 155	60 - 61	Color preset 14		
	156 - 157	61	Color preset 15		
	158 - 159	62	Color preset 16		
	160 - 161	63	Color preset 17		
	162 - 163	63 - 64	Color preset 18		
	164 - 165	64	Color preset 19		
	166 - 167	65	Color preset 20		
	168 - 169	66	Color preset 21		
	170 - 171	66 - 67	Color preset 22		
	172 - 173	67 - 68	Color preset 23		
	174 - 175	68	Color preset 24		
	176 - 177	69	Color preset 25		
	178 - 179	70	Color preset 26		
	180 - 181	70 - 71	Color preset 27		
	182 - 183	71	Color preset 28		
	184 - 185	72	Color preset 29		
	186 - 187	73	Color preset 30		
	188 - 189	73 - 74	Color preset 31		
	190 - 191	74 - 75	Color preset 32		
	192 - 193	75	Color preset 33		
194 - 195	76	Color preset 34			
196 - 197	77	Color preset 35			
198 - 199	77 - 78	Color preset 36			
200 - 220	78 - 86	'Color wheel rotation' effect Clockwise, fast → slow			
221 - 224	86 - 88	Stop (this will stop wherever the color is at the time)			
225 - 245	88 - 96	Counter-clockwise, slow → fast			
246 - 255	96 - 100	Open			
6	0 - 200	0 - 78	Zoom Flood → spot	Fade	200
	201 - 255	79 - 100	Overdrive min. → max.		

Table 2: DMX Protocol - 16-bit Extended Mode

Channel	DMX Value	Percent	Function	Fade type	Default value
7 and 8	0 - 32768	0 - 50	Beam twister, 16-bit (MSB and LSB) Index 0 → 360	Snap	0
	32769 - 40000	50 - 61	Disable		
	40001 - 49990	61 - 77	Rotation CW Fast → CW Slow		
	49991 - 50000	77	No rotation (lens stops at its current position)		
	50001 - 59990	77 - 92	Rotation CCW Slow → CCW Fast		
	59991 - 59999	92	Disable		
	60000 - 60099	92	Position 1: Wide		
	60100 - 60199	92	Position 2: Smooth		
	60200 - 60299	92	Position 3: Texture		
	60300 - 60399	92	Position 4: Dots		
	60400 - 60499	93	Position 5: Eye		
	60500 - 60599	93	Position 6: Donut		
	60600 - 60699	93	Position 7: Beam		
	60700 - 60799	93	Position 8: Beam 2		
	60800 - 60899	93	Position 9: Beam 3		
	60900 - 60999	93	Position 10: Beam 4		
	61000 - 61099	94	Position 11: Mixed		
	61100 - 61199	94	Position 12: Separation		
	61200 - 61299	94	Position 13: Separation 2		
	61300 - 61399	94	Position 14: Rays		
	61400 - 61499	94	Position 15: Halo		
61500 - 61599	94	Position 16: Two Areas			
61600 - 61699	94	Position 17: Clean Colors			
61700 - 61799	95	Position 18: Crossover			
61800 - 61999	95	<i>No function</i>			
62000 - 65355	95 - 100	Disable			
9	0 - 65535	0 - 100	Pan, 16-bit (MSB and LSB)	Fade	32768
10			Left → right (32768 = neutral)		
11	0 - 65535	0 - 100	Tilt, 16-bit (MSB and LSB)	Fade	32768
12			Up → down (32768 = neutral)		

Table 2: DMX Protocol - 16-bit Extended Mode

Channel	DMX Value	Percent	Function	Fade type	Default value
13	0 - 9	0 - 4	Fixture control/settings <i>(hold for number of seconds indicated to activate)</i>	Snap	0
	10 - 14	4 - 5	No function (disables calibration) – 5 sec.		
	15	6	Reset entire fixture – 5 sec.		
	16	6	Reset shutter/dimmer only – 5 sec.		
	17	7	Reset color only – 5 sec.		
	18	7	Reset beam only – 5 sec.		
	19 - 22	7 - 9	Reset pan and tilt only – 5 sec.		
	23	9	No function		
	24	9	Linear dimming curve – 1 sec. (menu override, setting unaffected by power off/on)		
	25	10	Square law dimming curve – 1 sec. (menu override, factory default setting, setting unaffected by power off/on)		
	26	10	Inverse square law dimming curve – 1 sec. (menu override, setting unaffected by power off/on)		
	27	11	S-curve dimming curve – 1 sec. (menu override, setting unaffected by power off/on)		
	28	11	No function		
	29	11	Fast pan and tilt speed – 1 sec. (default setting, menu override - setting returns to MENU setting after power on/off)		
	30	11	Smooth pan and tilt speed – 1 sec. (menu override - setting returns to MENU setting after power on/off)		
	31	12	Parameter shortcuts = ON (default)		
	32 - 35	12	Parameter shortcuts = OFF		
	36	13 - 14	No function		
	37	14	Enable video tracking		
	38	14	Disable video tracking		
	39	15	Extended color (default)		
	40 - 49	15	Calibrated color		
	50	16 - 19	No function		
	51	20	Regulated fan speed, fixed intensity (default)		
	52	20	Fixed fan speed, regulated intensity		
	53	20	Turn on control panel display – 1 sec.		
	54 - 99	21	Turn off control panel display – 1 sec.		
	100	21 - 39	No function		
	101	39	Enable calibration – 5 sec.		
	102	39	Store pan and tilt calibration – 5 sec.		
	103 - 110	40	Store dimmer calibration – 5 sec.		
	111	40 - 43	No function		
	112 - 113	43	Store Beam Twister calibration – 5 sec.		
	114	44	No function		
115	45	Store zoom calibration – 5 sec.			
116	45	Store pan calibration – 5 sec.			
117 - 198	45	Store tilt calibration – 5 sec.			
199	46 - 77	No function			
200 - 255	78	Reset all calibration values to defaults – 5 sec.			
200 - 255	78 - 100	No function			
14-18	No function - reserved for future use				

Color - Outer

19	0 - 255	0 - 100	Red 0 → 100%	Fade	255
20	0 - 255	0 - 100	Green 0 → 100%	Fade	255
21	0 - 255	0 - 100	Blue 0 → 100%	Fade	255

Color - Middle

22	0 - 255	0 - 100	Red 0 → 100%	Fade	255
23	0 - 255	0 - 100	Green 0 → 100%	Fade	255
24	0 - 255	0 - 100	Blue 0 → 100%	Fade	255

Table 2: DMX Protocol - 16-bit Extended Mode

Channel	DMX Value	Percent	Function	Fade type	Default value
Color - Center					
25	0 - 255	0 - 100	Red 0 → 100%	Fade	255
26	0 - 255	0 - 100	Green 0 → 100%	Fade	255
27	0 - 255	0 - 100	Blue 0 → 100%	Fade	255

Aura					
28	0 - 19 20 - 49 50 - 200 201 - 210 211 - 255	0 - 7 8 - 19 20 - 78 79 - 82 82 - 100	Strobe/shutter effect Shutter closed Shutter open Strobe, slow → fast Shutter open Random strobe, slow → fast	Snap	30
29	0 - 255	0 - 100	Dimmer (MSB) Closed → open	Fade	0
30	0 - 255	0 - 100	Red 0 → 100%	Fade	255
31	0 - 255	0 - 100	Green 0 → 100%	Fade	255
32	0 - 255	0 - 100	Blue 0 → 100%	Fade	255

Table 2: DMX Protocol - 16-bit Extended Mode

Channel	DMX Value	Percent	Function	Fade type	Default value
33	0 - 10	0 - 4	'Color wheel' color selection effect Open. RGB color mixing enabled	Snap	0
	11 - 15	4 - 6	Color 1 - LEE 790 - Moroccan pink		
	16 - 20	6 - 8	Color 2- LEE 157 - Pink		
	21 - 25	8 - 10	Color 3 - LEE 332 - Special rose pink		
	26 - 30	10 - 12	Color 4 - LEE 328 - Follies pink		
	31 - 35	12 - 14	Color 5 - LEE 345 - Fuchsia pink		
	36 - 40	14 - 16	Color 6 - LEE 194 - Surprise pink		
	41 - 45	16 - 18	Color 7 - LEE 181 - Congo Blue		
	46 - 50	18 - 20	Color 8 - LEE 071 - Tokyo Blue		
	51 - 55	20 - 21	Color 9 - LEE 120 - Deep Blue		
	56 - 60	22 - 23	Color 10 - LEE 079 - Just Blue		
	61 - 65	24 - 25	Color 11 - LEE 132 - Medium Blue		
	66 - 70	26 - 27	Color 12 - LEE 200 - Double CT Blue		
	71 - 75	28 - 29	Color 13 - LEE 161 - Slate Blue		
	76 - 80	30 - 31	Color 14 - LEE 201 - Full CT Blue		
	81 - 85	32 - 33	Color 15 - LEE 202 - Half CT Blue		
	86 - 90	34 - 35	Color 16 - LEE 117 - Steel Blue		
	91 - 95	36 - 37	Color 17 - LEE 353 - Lighter Blue		
	96 - 100	38 - 39	Color 18 - LEE 118 - Light Blue		
	101 - 105	39 - 41	Color 19 - LEE 116 - Medium Blue Green		
	106 - 110	41 - 43	Color 20 - LEE 124 - Dark Green		
	111 - 115	43 - 45	Color 21 - LEE 139 - Primary Green		
	116 - 120	45 - 47	Color 22 - LEE 089 - Moss Green		
	121 - 125	47 - 49	Color 23 - LEE 122 - Fern Green		
	126 - 130	49 - 51	Color 24 - LEE 738 - JAS Green		
	131 - 135	51 - 53	Color 25 - LEE 088 - Lime Green		
	136 - 140	53 - 55	Color 26 - LEE 100 - Spring Yellow		
	141 - 145	55 - 57	Color 27 - LEE 104 - Deep Amber		
	146 - 150	57 - 59	Color 28 - LEE 179 - Chrome Orange		
	151 - 155	59 - 61	Color 29 - LEE 105 - Orange		
	156 - 160	61 - 63	Color 30 - LEE 021 - Gold Amber		
	161 - 165	63 - 64	Color 31 - LEE 778 - Millennium Gold		
	166 - 170	65 - 66	Color 32 - LEE 135 - Deep Golden Amber		
	171 - 175	67 - 68	Color 33 - LEE 164 - Flame Red		
	176 - 180	69 - 70	Color 34 - Magenta		
	181 - 185	71 - 72	Color 35 - Medium Lavender		
186 - 190	73 - 74	Color 36 - White			
			'Color wheel rotation' effect		
	191 - 214	75 - 84	Clockwise, fast → slow		
	215 - 219	84 - 86	Stop (this will stop wherever the color is at the time)		
	220 - 243	86 - 95	Counter-clockwise, slow → fast		
			Random colors		
	244 - 247	95 - 96	Fast		
	248 - 251	97 - 98	Medium		
	252 - 255	98 - 100	Slow		

Table 2: DMX Protocol - 16-bit Extended Mode

MSB = Most significant byte

LSB = Least significant byte

Color temperature control data

The table below gives the color temperatures obtained when specific DMX values are sent on the color temperature control channel.

DMX value	Col. temp.	DMX value	Col. temp.	DMX value	Col. temp.	DMX value	Col. temp.
11	2000	51	4000	91	6000	131	8000
12	2050	52	4050	92	6050	132	8050
13	2100	53	4100	93	6100	133	8100
14	2150	54	4150	94	6150	134	8150
15	2200	55	4200	95	6200	135	8200
16	2250	56	4250	96	6250	136	8250
17	2300	57	4300	97	6300	137	8300
18	2350	58	4350	98	6350	138	8350
19	2400	59	4400	99	6400	139	8400
20	2450	60	4450	100	6450	140	8450
21	2500	61	4500	101	6500	141	8500
22	2550	62	4550	102	6550	142	8550
23	2600	63	4600	103	6600	143	8600
24	2650	64	4650	104	6650	144	8650
25	2700	65	4700	105	6700	145	8700
26	2750	66	4750	106	6750	146	8750
27	2800	67	4800	107	6800	147	8800
28	2850	68	4850	108	6850	148	8850
29	2900	69	4900	109	6900	149	8900
30	2950	70	4950	110	6950	150	8950
31	3000	71	5000	111	7000	151	9000
32	3050	72	5050	112	7050	152	9050
33	3100	73	5100	113	7100	153	9100
34	3150	74	5150	114	7150	154	9150
35	3200	75	5200	115	7200	155	9200
36	3250	76	5250	116	7250	156	9250
37	3300	77	5300	117	7300	157	9300
38	3350	78	5350	118	7350	158	9350
39	3400	79	5400	119	7400	159	9400
40	3450	80	5450	120	7450	160	9450
41	3500	81	5500	121	7500	161	9500
42	3550	82	5550	122	7550	162	9550
43	3600	83	5600	123	7600	163	9600
44	3650	84	5650	124	7650	164	9650
45	3700	85	5700	125	7700	165	9700
46	3750	86	5750	126	7750	166	9750
47	3800	87	5800	127	7800	167	9800
48	3850	88	5850	128	7850	168	9850
49	3900	89	5900	129	7900	169	9900
50	3950	90	5950	130	7950	170	9950
						171	10000

Table 3: DMX Values and color temperature

Control panel menus

Applicable when running MAC Quantum Wash firmware version 1.1.0.

Menu level 1	Menu level 2	Menu level 3	Menu level 4	Notes (Default settings in bold print)	
DMX ADDRESS	1 – XXX			DMX address (default address = 1). The DMX address range is limited so that the fixture will always have enough DMX channels within the 512 available.	
CONTROL MODE	BASIC			16-bit basic DMX mode	
	EXTENDED			16-bit extended DMX mode	
FIXTURE ID	0 – 9999	User-settable fixture ID number		0	
PERSONALITY	PAN/TILT	PAN INVERT	ON/OFF	Inverse DMX pan control: right → left	
		TILT INVERT	ON/OFF	Inverse DMX tilt control: down → up	
	SPEED	PAN/TILT	FAST		Optimize pan/tilt movement for speed
			SMOOTH		Optimize pan/tilt movement for smoothness
		EFFECT	FOLLOW P/T		Effects speed follows the speed setting applied to pan and tilt via DMX or in control menu
			FAST		Optimize effects movement for speed
			SLOW		Optimize effects movement for smoothness
	DIMMER CURVE	LINEAR			Optically linear dimming curve
		SQUARE LAW			Square law dimming curve
		INV SQ LAW			Inverse square law dimming curve
		S-CURVE			S-curve (fixture emulates incandescent lamp voltage linear RMS dimming curve)
	COLOR MODE	EXTENDED COLOR			Color mixing optimized for saturation
		CALIBRATED COLOR (COMMON COLOR in SW v.1.1.0)			Color mixing optimized for even color rendition across fixtures
	VIDEO TRACKING	ENABLED			Color fading optimized for speed of color changes
		DISABLED			Color fading optimized for smoothness
	DMX RESET	ON			Fixture can be reset via DMX
		OFF			Fixture cannot be reset via DMX (can be overridden: see DMX protocol)
	EFFECT SHORTCUT	ON			Effects take shortest route during changes, crossing open positions if necessary
		OFF			Effects avoid open positions during effects changes
	COOLING MODE	REGULATE FANS			Fans optimized for light intensity (temperature controlled by regulating fan speed, light output unaffected)
REGULATE INTENSITY				Fans optimized for quietness (temperature controlled by regulating light output, fan speed kept low)	

Table 4: Control menus

Menu level 1	Menu level 2	Menu level 3	Menu level 4	Notes (Default settings in bold print)
PERSONALITY (continued)	DISPLAY	DISPLAY SLEEP	ON	Display permanently on
			2 MINUTES	Display goes into sleep mode 2 minutes after last key press
			5 MINUTES	Display goes into sleep mode 5 minutes after last key press
			10 MINUTES	Display goes into sleep mode 10 minutes after last key press
		DISPLAY INTENSITY	10 ... 100	Set display intensity in % (default = 100)
		DISPLAY ROTATION	NORMAL / ROTATE 180	Display orientation normal or rotated 180°
	DISPLAY CONTRAST	1 ...100	Adjust contrast of display (default = 41)	
ERROR MODE		NORMAL		Enable error messages and warnings in display
		SILENT		Disable error messages and warnings in display (the status LED will still light to indicate fixture status if an error has been detected or the fixture has a warning)
DEFAULT SETTINGS	FACTORY DEFAULT	LOAD	ARE YOU SURE? YES/NO	Return all settings (except calibrations) to factory defaults
	CUSTOM 1	LOAD	ARE YOU SURE? YES/NO	Load Custom Settings 1
		SAVE	ARE YOU SURE? YES/NO	Save fixture's current settings as Custom Settings 1
	CUSTOM 2	LOAD	ARE YOU SURE? YES/NO	Load Custom Settings 2
		SAVE	ARE YOU SURE? YES/NO	Save fixture's current settings as Custom Settings 2
	CUSTOM 3	LOAD	ARE YOU SURE? YES/NO	Load Custom Settings 3
		SAVE	ARE YOU SURE? YES/NO	Save fixture's current settings as Custom Settings 3
	INFORMATION	POWER ON TIME	TOTAL	0 ... XXX HR
RESETTABLE			CLEAR COUNTER? YES/NO	Display hours fixture has been powered on since last counter reset (user-resettable)
POWER ON CYCLES		TOTAL	0 ... XXX HR	Display number of times fixture has been powered on since manufacture (not user-resettable)
		RESETTABLE	CLEAR COUNTER? YES/NO	Display number of times fixture has been powered on since last counter reset (user-resettable)
SW VERSION*		XX.XX.XX		Displays currently active software version
RDM UID*		4D50.XXXXXXXX		Displays fixture's unique RDM ID
FAN SPEEDS*		HEAD FAN 1 ... BASE FAN 3	0 - XXX RPM	Scroll to displays current speed of each cooling fan (head and base)
TEMPERATURES*		PAN/TILT ... DCDC PCB	X C	Displays temperature in °C of all PCBs
DMX LIVE*		EXTENDED MODE	RATE	0 - 44 HZ
	QUALITY		0 - 100%	Percent of packets received
	START CODE		0 - 255	Value of the DMX start code
	STROBE ... AURA COLOR WHEEL		XXX	Scroll to see values received on each DMX channel in 16-bit Extended Mode
	BASIC MODE	RATE	0 - 44 HZ	DMX transmission speed in packets per second
		QUALITY	0 - 100%	Percent of packets received
		START CODE	0 - 255	Value of the DMX start code
		STROBE ... CONTROL	XXX	Scroll to see values received on each DMX channel in 16-bit Basic Mode

Table 4: Control menus

Menu level 1	Menu level 2	Menu level 3	Menu level 4	Notes (Default settings in bold print)	
TEST*	TEST ALL			Run test sequence of all functions To test a specific function, se Up/Down buttons to scroll through functions and pause. Press Enter to restart test sequence. Press Menu button to exit test	
	TEST LEDES			Run test sequence of LEDs only. To test a specific LED group, se Up/Down buttons to scroll through groups and pause. Press Enter to restart test sequence. Press Menu button to exit test	
	TEST EFFECTS	ZOOM		Run test sequence of zoom functions. Press Menu button to stop test	
		BEAM TWISTER		Run test sequence of Beam Twister functions. Press Menu button to stop test	
	TEST PAN/TILT	PAN		Run test sequence of pan functions. Press Menu button to stop test	
		TILT		Run test sequence of tilt functions. Press Menu button to stop test	
MANUAL CONTROL*	EXTENDED MODE	BASIC MODE			
	RESET	RESET		Reset fixture	
	STROBE ... AURA BLUE	STROBE -- CONTROL		Scroll through effects to manually control an effect	
SERVICE	ERROR LIST	Empty or up to 20 errors		Display any errors in memory	
	FAN CLEAN	ON/OFF		Activate fan cleaning	
	PT FEEDBACK	ON		Enable pan/tilt position feedback systems	
		OFF		Disable pan/tilt position feedback	
	CALIBRATION	ZOOM		0.00 ...+/- xx%	Define zoom home position
		PAN		0.00 ...+/- xx%	Define pan home position
		TILT		0.00 ...+/- xx%	Define tilt home position
		LOAD DEFAULTS	LOAD		Load factory default calibration settings
		SAVE DEFAULTS	SAVE		Replace factory default calibration settings with current calibration settings
	USB	NO DEVICE			No USB device present or no firmware on USB device
		UPDATING FILES			Fixture updating internal memory from USB device
		AVAILABLE FIRMWARE		XX.XX.XX ... XX.XX.XX	Select firmware from versions stored in internal memory. Scroll to select version, then press Enter and confirm your choice to update

Table 4: Control menus

* Menus marked * are available only when the fixture is connected to mains power. All other menus are available in mains- and battery-powered operation.

Service and display messages

The MAC Quantum Wash gives service and maintenance information by displaying a large 3- or 4-character short code and a smaller full-text message in the fixture's display. The short code is visible at a distance, allowing easier reading with the fixture still in the rig, for example, while the full-text message gives more detailed information.

Warning messages

Warning messages indicate that either:

- problems might appear in the future if no action is taken, or
- the user needs to pay special attention to a function or procedure when working with the fixture.

The MAC Quantum Wash communicates warnings as follows:

- Warning codes are shown continuously in the display and disappear when the user reacts to the warning.
- If more than one warning is detected, all warnings are displayed in sequence.
- If the display is inactive, the fixture's status LED (see Figure 1 on page 7) flashes orange to indicate that there is a warning. Activating the display will show the warning.

The possible warning messages are listed in Table 5 below:

Short code	Long message and explanation
AUTW	AURA TMP HIGH Aura temperature sensor detects abnormally high operating temperature.*
BANK	BANK NO ACCESS Error unpacking firmware bank during/after software upload. Fixture will continue to operate on existing firmware. Warning message is cleared by a successful software upload or at the next power off/on cycle.
BETW	BEAM TEMP HIGH Beam temperature sensor detects abnormally high operating temperature.*
DCTW	DC TEMP HIGH DC PCB sensor detects abnormally high operating temperature.*
LDTW	LED DRV TMP HIGH LED driver temperature sensor detects abnormally high operating temperature.*
PFTW	PFC TEMP HIGH PFC unit temperature sensor detects abnormally high operating temperature.*
PTTW	PT TEMP HIGH Pan/tilt PCB sensor detects abnormally high operating temperature.*
SERV	SERVICE MODE Fixture in service mode.
SL W	SAFETY LOOP A safety loop error occurred but is no longer active. Warning message is cleared at the next power off/on cycle.
UITW	UI TEMP HIGH User interface (LCD display and control panel) PCB sensor detects abnormally high operating temperature.*
ZFTW	ZF TEMP HIGH Zoom PCB sensor detects abnormally high operating temperature.*

Table 5: Warning messages

**High temperature warnings are canceled as soon as temperature returns to normal. If temperature reaches cutoff level, the warning is replaced by a cutoff error message.*

Error messages

Error messages indicate that a problem is present. The MAC Quantum Wash communicates errors as follows:

- Error messages flash in the display.
- If more than one error is detected, the fixture flashes all errors three times each.
- Errors are shown in the display regardless of display status: they override an inactive display and any other information that the display might be showing.
- If an error is present, the status LED flashes red.

The possible error messages are listed in Table 6 below:

Short code	Long message and explanation
ACER	AURA CALIB ERROR Aura calibration error.
AUTC	AURA TMP SEN ERR Aura temperature sensor error.
AUTE	AURA TMP SEN ERR Aura temperature sensor error.
BCER	BEAM CALIB ERROR Beam calibration error.
BETC	BEAM TMP SEN ERR Beam temperature sensor error.
BETE	BEAM TMP SEN ERR Beam temperature sensor error.
BSER	BEAM TWIST SENSOR ERR Beam twister position indexing system timeout.
BTER	BEAM TWIST ERR Beam twister error.
BTSA	BEAM TWIST SENSOR ADJ Beam twister sensor adjustment error.
CELD	COM ERR LED DRV LED driver communication error.
COLD	FIXTURE COLD Fixture too cold. Physical movement of effects is disabled until fixture has warmed up.
DCTC	DC TEMP CUT OFF DC PCB temperature cutoff.
DCTE	DC TEMP SEN ERR DC PCB temperature sensor error.
FAN	BASE 1 FAN ERR
FAN	BASE 2 FAN ERR
FAN	BASE 3 FAN ERR
FAN	HEAD FAN 1 ERR
FAN	HEAD FAN 1 ERR
FAN	HEAD FAN 1 ERR
FAN	HEAD FAN 1 ERR
FBEB	BEAM TWIST FBACK ERR Beam twister position feedback system timeout. Fixture is unable to correct beam twister position.
FBEP	PAN FBACK ERR Pan position magnetic indexing system timeout. Fixture is unable to correct pan position (but pan movement will often still be possible).
FBET	TILT FBACK ERR Tilt position magnetic indexing system timeout. Fixture is unable to correct tilt position (but tilt movement will often still be possible).
FBEZ	ZOOM FBACK ERR Zoom position indexing system timeout. Fixture is unable to correct zoom position.

Table 6: Error messages

Short code	Long message and explanation
LDTC	LED TEMP SEN ERR LED board temperature sensor error.
LDTE	LED TEMP SEN ERR LED board temperature sensor error.
MMER	MISSING MODULE ERR Impossible to communicate with a module that should be present. Module missing or not correctly connected.
PAER	PAN ERROR Pan position electrical indexing system timeout.
PFTC	PFC TEMP CUT OFF Power factor correction system temperature cutoff.
PFTE	PFC TEMP SEN ERR Power factor correction system temperature sensor error.
PSER	PAN SENSOR ERROR Fixture unable to retrieve reliable data from pan position sensor.
PTCM	P/T SENSOR ADJUST Pan/tilt sensors are incorrectly adjusted.
SLER	SAFETY LOOP Safety loop circuit activated. A temperature circuit breaker has shut down LEDs. Circuit breaker resets automatically after temperature has returned to normal operating range.
TIER	TILT ERROR Tilt position electrical indexing circuit timeout.
TSER	TILT SENSOR ERR Fixture unable to retrieve reliable data from tilt position sensor.
UELD	UPL ERR LED DRV Could not upload new LED driver firmware during a firmware upload. Error cleared when new firmware is uploaded successfully or power is cycled off and on.
UITC	UI TEMP CUTOFF User interface (LCD display and control panel) temperature cutoff activated.
ZSER	ZOOM SENSOR ERR Zoom position electrical indexing system timeout.

Table 6: Error messages

The fixture reports a calibration error if valid calibration data is not detected in EEPROM. The fixture may be unable to read/write calibration data to EEPROM.



www.martin.com • Olof Palmes Allé 18 • 8200 Aarhus N • Denmark
Tel: +45 8740 0000 • Fax +45 8740 0010