

PowerDAQ AO Series User Manual

**PD2/PDXI-AO High-Density Analog-Output Boards
PD2/PDXI-AO-HS High-Speed Analog-Output Boards
PD2-AO-HC High-Current Analog-Output Boards**

August 2004 Edition

PN Man-AO-4-0804

No part of this publication may be reproduced, stored in a retrieval system, or transmitted, in any form by any means, electronic, mechanical, by photocopying, recording, or otherwise without prior written permission.

Fourth Edition

August 2004 Printing

Information furnished in this manual is believed to be accurate and reliable. However, no responsibility is assumed for its use, or for any infringements of patents or other rights of third parties that may result from its use.

All product names listed are trademarks or trade names of their respective companies.

See UEI's website for complete Terms and Conditions of sale:
<http://www.ueidaq.com/company/terms.asp>

Contacting United Electronic Industries

Mailing Address:

611 Neponset St
Canton, MA 02021
U.S.A.

Support:

Telephone: (781) 821-2890
Fax: (781) 821-2891

Also see the FAQs and online "Live Help" feature on our web site.

Internet Access:

| | |
|----------|--|
| Support | support@ueidaq.com |
| Web site | www.ueidaq.com |
| FTP site | ftp://ftp.ueidaq.com |

Table of Contents

| | |
|---|-----------|
| 1. Introduction | 1 |
| Who should read this manual? | 1 |
| Conventions..... | 2 |
| Organization of this manual..... | 3 |
| 2. AO Series Features | 5 |
| Overview | 5 |
| Features..... | 5 |
| Analog-output applications | 6 |
| AO Series models..... | 7 |
| 3. Installation and Configuration..... | 9 |
| Before you begin..... | 9 |
| System requirements | 9 |
| Packing list | 9 |
| Software installation..... | 10 |
| Installing the SDK and Windows driver | 10 |
| Linux driver..... | 11 |
| Realtime Linux kernel patches..... | 11 |
| Compiling and installing Linux kernels | 12 |
| Loading and testing the Linux driver..... | 12 |
| QNX driver | 13 |
| Compiling and Installing the QNX driver..... | 13 |
| Loading and testing the QNX driver | 13 |
| Using the QNX library from C/C++ | 14 |
| Hardware installation..... | 15 |
| Base address, DMA and interrupt settings..... | 16 |
| Confirming the installation | 17 |
| Synchronizing multiple boards | 18 |
| Remote sensing | 19 |
| Connectors and pinouts..... | 20 |
| PD2-AO-8/16, -16/16 and -32/16..... | 20 |
| PD2-AO-32/16HC..... | 25 |
| PD2-AO-96/16..... | 26 |
| PD2-AO-96/16 | 27 |
| Panel connection, PD2..... | 29 |
| PDXI-AO-8/16, -16/16, -32/16 | 30 |
| Panel connection, PDXI..... | 35 |
| 4. Architecture | 37 |
| Functional Overview..... | 37 |
| The Analog Output subsystem..... | 39 |

Table of Contents

| | |
|---|-----------|
| The Digital I/O subsystem..... | 40 |
| Counter/timer subsystem..... | 40 |
| Interrupt lines..... | 41 |
| Programming Model | 41 |
| Modes and performance..... | 42 |
| Programming Techniques | 44 |
| General procedures | 44 |
| Opening a subsystem..... | 45 |
| API calls for opening/closing a subsystem | 45 |
| Driver structure | 46 |
| Data format..... | 47 |
| Output datapath | 48 |
| Buffer structure | 49 |
| Frame..... | 49 |
| Scan | 49 |
| Channel string..... | 49 |
| 5. Analog-Output Subsystem..... | 51 |
| Data/control flow..... | 51 |
| Operating modes and parameters | 51 |
| Output modes..... | 51 |
| Transfer modes..... | 52 |
| Update methods | 52 |
| Update rates (speeds)..... | 53 |
| Output ranges..... | 53 |
| Calibration subsystem | 54 |
| Resets | 54 |
| Clocking and triggering | 55 |
| Simultaneous updates | 57 |
| Programming onboard logic..... | 58 |
| Single-Point Update mode | 58 |
| Calling sequence | 58 |
| Buffered updates..... | 59 |
| Event-Based Waveform mode..... | 59 |
| Waveform Regenerate mode | 60 |
| Direct DSP Buffer Access mode | 60 |
| Buffered update settings | 62 |
| Buffered update examples..... | 63 |
| Buffered update configuration parameters | 64 |
| Buffer data format..... | 65 |
| AO subsystem configuration..... | 66 |
| Hardware-update channel setup..... | 67 |
| Channel-list configuration..... | 67 |
| Programming model for buffered modes..... | 71 |
| 6. Digital I/O Subsystem | 81 |
| Architecture | 81 |

| | |
|--|------------|
| Programming Techniques..... | 81 |
| Polled I/O..... | 81 |
| Change-of-state interrupts on digital input..... | 82 |
| 7. Counter/Timer Subsystem..... | 85 |
| Architecture..... | 85 |
| Programming the counter/timers | 86 |
| 8. Software Support | 89 |
| PowerDAQ SDK Structure..... | 89 |
| Windows device drivers | 90 |
| Windows DLLs..... | 90 |
| Language libraries..... | 91 |
| Include files..... | 91 |
| Linux support..... | 92 |
| QNX support..... | 93 |
| Example programs..... | 93 |
| Third-party software support | 94 |
| LabVIEW VIs for analog output..... | 95 |
| Appendix A: Specifications..... | 99 |
| PDX-AO specifications | 99 |
| Analog-output subsystem..... | 99 |
| Digital Input/Output subsystem..... | 100 |
| DSP-based subsystems | 101 |
| DC electrical characteristics for DSP-based subsystems | 101 |
| Appendix B: Accessories | 103 |
| Screw-Terminal Panels (PD2/PDXI) | 103 |
| BNC Panels (PD2/PDXI)..... | 103 |
| Cables (PD2/PDXI) | 104 |
| Other Accessories (PD2/PDXI)..... | 104 |
| OEM Header Distribution Connector..... | 105 |
| Appendix C: Board-level AO Command Format..... | 107 |
| Single-Point Update commands..... | 109 |
| Address space/commands..... | 109 |
| Non-buffered mode control bits | 110 |
| Write commands | 110 |
| Read commands..... | 111 |
| Call-sequence example | 112 |
| Using AO functions of the SDK..... | 112 |
| Using <code>_PdDIO256RegXX</code> functions..... | 112 |
| Appendix D: Calibration..... | 113 |
| Calibration IC and DAC assignments..... | 114 |
| Appendix E: Advanced Circular Buffer | 119 |

Table of Contents

| | |
|------------------------------|------------|
| Glossary | 123 |
| Index..... | 141 |
| Reader Feedback | 145 |

1. Introduction

This manual describes the features and functions of the PowerDAQ AO Series of analog-output boards. These high-performance systems support high-density 16-bit analog output, digital I/O, and user counter/timers for either the PCI bus (PD2 family) or PXI/CompactPCI-bus (PDXI family). The cards covered in this manual are the following:

- PD2-AO-8/16
- PD2-AO-16/16
- PD2-AO-32/16
- PD2-AO-32/16HC
- PD2-AO-32/16HS
- PD2-AO-96/16
- PD2-AO-96/16HS

- PDXI-AO-8/16
- PDXI-AO-8/16HS
- PDXI-AO-16/16
- PDXI-AO-16/16HS
- PDXI-AO-32/16
- PDXI-AO-32/16HS

Who should read this manual?

This manual has been designed to make the installation, configuration and operation of our PowerDAQ analog-output boards as straightforward as possible. However, it assumes that the user has basic PC skills and is familiar with Microsoft Windows 2000/NT/XP, QNX or Linux (Red Hat or Suse distributions) as well as leading realtime patches (FSMLabs' RTLinux and RTAI).

Conventions

To help you get the most out of this manual and our products, please note that we use the following conventions:

**TIP**

Tips are designed to highlight quick ways to get the job done, or reveal good ideas you might not discover on your own.

**Note**

Notes alert you to important information.

CAUTION! *Caution advises you of precautions to take to avoid injury, data loss, and damage to your boards or a system crash.*

Text formatted in **bold** typeface generally represents text that should be entered verbatim. For instance, it can represent a command, as in the following example: “You can instruct users how to run setup using a command such as **setup.exe**.”

Organization of this manual

This PowerDAQ PDX-AO User Manual is organized as follows:

Chapter 1—Introduction

This chapter gives you an overview of PowerDAQ Analog Output Series board features, the various models available and what you need to get started.

Chapter 2—AO Series Features Overview

This chapter provides an overview of the key features of the PowerDAQ AO Series and detailed information on the various models currently available.

Chapter 3—Installation and Configuration

This chapter explains how to install and configure your PowerDAQ AO Series board. Among other things, it shows where various I/O connectors are located on the boards, how to connect them (even when using remote sensing), and also shows their pinout definitions.

Chapter 4—Architecture

This chapter discusses the functionality of the subsystems of your PowerDAQ AO Series board, and it gives an overview of the programming model, showing how various cards and software modules intercommunicate. It further reviews the key operating modes of the AO subsystem, and then it introduces you to the buffer structure including the concept of scans and frames.

Chapter 5—Analog-Output Subsystem

This chapter gives extensive details about this subsystem including the various operating modes, performance parameters, clocking and triggering as well as details on how to configure and program all these features. .

Chapter 6—Digital I/O Subsystem

This chapter reviews the architecture and key operating/programming principles you need to take advantage of the digital I/O resources on an AO Series board.

Chapter 7—Counter/Timer Subsystem

This chapter gives the information you need to use the three onboard counter/timers that are a feature of all AO Series boards.

Chapter 8—Support Software

This chapter provides an overview of the resources on the PowerDAQ SDK including a discussion of the SDK structure, a review of key drivers, DLLs, libraries and include files, details about programming under LabVIEW, and how to work with an OS other than Windows. It wraps up with a review of key example programs.

Appendix A – Specifications

This chapter lists the PowerDAQ AO Series hardware specifications.

Appendix B – Accessories

This appendix provides a list of PowerDAQ accessories available for use with AO Series boards.

Appendix C – Board-level AO Command Format

This section describes commands on the PowerDAQ AO boards that can be used for low-level firmware or software programming. They also serve to help you better understand AO board functionality.

Appendix D: Calibration

This section gives details on the structure that holds calibration values along with other nonvolatile information

Appendix E: Advanced Circular Buffer

This application note describes the operation of the ACB, a section of host memory a PowerDAQ board uses to alleviate many of the latency problems that arise with Windows.

Glossary

This is an alphabetical listing of key terms you will encounter in working with PowerDAQ cards and test systems in general.

Index

This is an alphabetical listing of the topics covered in this manual.

Feedback

We are interested in any feedback you might have concerning our products and manuals. A Reader Evaluation form is available on the last page of the manual.

2. AO Series Features

This chapter provides an overview of the key features of PowerDAQ AO Series analog-output cards and detailed information on the various models currently available. It also lists what you need to get started.

Overview

Thank you for purchasing a PowerDAQ AO Series board. These advanced boards feature an onboard DSP that allows simultaneous operation of all I/O subsystems without host intervention. In addition, the DSP runs a firmware-based command interpreter that makes it easy and convenient to program these cards from virtually any programming language using the same API.

PowerDAQ AO Series boards are configured with either 8, 16, 32 or 96 independent analog-output channels (PDXI versions are available with 32 channels max). They feature 16-bit D/A converters and allow you to configure the startup states for each channel (200 msec maximum delay between system reset and power-on value loading). The on-board DSP and PCI interface allow you to use any or all of the three 24-bit counter timers, high-speed IRQ/external clock lines, eight digital inputs and eight high-drive TTL digital outputs (that source 32 mA or sink 64 mA).

Features

The major features of PowerDAQ AO boards are:

- 24-bit Motorola 56301 digital signal processor running at 66 MHz (100 MHz on -HS models)
- PCI host interface (PCI 2.1 compliant)
- 8, 16, 32 or 96 D/A converters, 16 bits, $\pm 10V$

Note Custom output voltage ranges are available; contact UEI sales department for availability. At this time, we offer $\pm 2.5V$, $\pm 5V$ -10-0V and 0-10V configurations on special order.

- DC to 100 kHz throughput per D/A
- 1.5 MHz per-board maximum aggregate update rate (3.2 MHz on -HS models)
- Fixed-length or unlimited-size channel lists
- Asynchronous or simultaneous update modes for all D/As
- Per-channel calibration
- Single-ended outputs (AGND used as return)

- Sense lines for each D/A—standard on PD2-AO-32/16HC; available upon request at time of order for PD2-AO-8/16, -16/16 and -32/16; jumper-selectable on PDXI models (only for output channels 0-15). Sense lines not available on high-density 96-channel PD2-AO-96/16 board.
- User-defined power-up states for each D/A
- Direct access to the output FIFO for advanced applications
- Eight digital inputs
- Eight digital outputs
- Three 24-bit counter/timers
- Counters, interrupt and synchronization inputs
- On-board 2k-sample FIFO (located in DSP memory)
- 64k-sample FIFO upgrade option (comes standard on -HS models)
- Drivers in PowerDAQ Software Suite for all popular operating systems, programming languages and test applications.

Note For a full list of specifications, see *Appendix A: Specifications*.

Analog-output applications

PowerDAQ AO Series boards provide many powerful features that allow these boards to cover a wide range of applications. The most common of these are:

- Process control
- ATE (automatic test equipment)
- Closed-loop servo control
- Motor control
- Complex continuous multichannel waveform generation
- Telecommunications equipment control.

The digital I/O subsystem finds use in these applications:

- Electromechanical relay control
- Solid-state relay interfacing
- Alarm-system sensors
- Digital motion control

The counter/timer subsystem finds use in these applications:

- Pulse-width modulation
- Frequency counting
- Pulse generation

Note The easiest way to expand the possibilities of an AO Series board is to use it in a system along with a PD2/PDXI-MF(S) multifunction board.

AO Series models

PowerDAQ PDx-AO model numbers are derived as follows:

[Bus] - AO - [Channels] / [Resolution] [Options]

where for bus you can choose

- PD2 PCI bus
- PDXI CompactPCI / PXI bus

and for options you can choose

- HC high current
- HS high speed (with 100-MHz DSP)

| Models | AO Features |
|-----------------|--|
| PD2-AO-8/16 | PCI bus, 8 16-bit D/A channels |
| PD2-AO-16/16 | PCI bus, 16 16-bit D/A channels |
| PD2-AO-32/16 | PCI bus, 32 16-bit D/A channels |
| PD2-AO-32/16HC | PCI bus, 32 16-bit D/A channels, high current |
| PD2-AO-32/16HS | PCI bus, 32 16-bit D/A channels, high speed |
| PD2-AO-96/16 | PCI bus, 96 16-bit D/A channels |
| PD2-AO-96/16HS | PCI bus, 96 16-bit D/A channels, high speed |
| PDXI-AO-8/16 | PXI/CPCI bus, 8 16-bit D/A channels |
| PDXI-AO-8/16HS | PXI/CPCI bus, 8 16-bit D/A channels, high speed |
| PDXI-AO-16/16 | PXI/CPCI bus, 16 16-bit D/A channels |
| PDXI-AO-16/16HS | PXI/CPCI bus, 16 16-bit D/A channels, high speed |
| PDXI-AO-32/16 | PXI/CPCI bus, 32 16-bit D/A channels |
| PDXI-AO-32/16HS | PXI/CPCI bus, 32 16-bit D/A channels, high speed |

Table 2.1—PowerDAQ AO Series models

All PowerDAQ AO boards have the following additional features:

- Digital inputs: Eight static lines
- Digital outputs: Eight static lines
- Clock/trigger/update lines
- Counter/timers: Three 24-bits units (33 MHz clocked internally, 16.5 MHz clocked externally)

3. Installation and Configuration

This chapter describes the installation and configuration of the hardware and software for a PowerDAQ AO Series board.

Before you begin

Before installing your PowerDAQ AO board, be sure to read and understand the following information.

System requirements

To install and run a PowerDAQ AO board you need the following:

- A PCI-bus system, a PXI-bus system or a CompactPCI-bus system with a free slot, a Pentium-class processor, and a BIOS compatible with the PCI Specifications 2.1 or greater.
- Windows NT 4.0 / 2000 / XP, Linux, Realtime Linux or QNX operating system

Note PowerDAQ drivers starting with v3.0 do not support Windows 95/98/Me. Previous versions of our drivers that do function with these earlier releases of Windows are available from our Customer Support department.

- At least 32M bytes of RAM for Windows NT, and 64M bytes for Windows 2000/XP. (Generally 64M bytes of RAM are required for the latest version of Linux, and 16M bytes are needed for QNX. (With any OS, we recommend at least 128M of RAM for best performance)
- The PowerDAQ Software Suite CD, which ships with your AO Series board. You can always download the latest version of this support software at no charge from www.ueidaq.com/download

Packing list

In your PowerDAQ package you should have received the following:

- a PowerDAQ AO Series board
- a calibration certificate
- this User Manual

- a CD containing the PowerDAQ Software Suite, including the full Software Development Kit (SDK) and documentation.

CAUTION! PowerDAQ boards contain sensitive electronic components. They are shipped in an anti-static bag to protect against electrostatic charges that might damage the board. To avoid damage, you should:

- Ensure you are properly grounded with a wrist strap or some other means.
- Discharge any static electricity by touching the metal part of your PC while holding the board in its antistatic bag.
- When you remove the board from the antistatic bag, save the bag for later possible use such as to store the board.
- Inspect the board for any damage. If you find any problems, notify the UEI sales team or your distributor for instructions on how to return the board.

Software installation

Note The PowerDAQ SDK must be installed before you plug in a PowerDAQ board to ensure that the driver properly detects the board.

Note All third-party software must be installed prior to installing the PowerDAQ SDK. If you added/installed any third-party software after you installed the PowerDAQ SDK, the best way to ensure proper support for that package within the PowerDAQ environment is to uninstall and reinstall it.

Installing the SDK and Windows driver

To install the PowerDAQ SDK:

1. Start your PC and, if running Windows NT, 2000 or XP, log in as an administrator.
2. Insert the PowerDAQ Software Suite CD into your CD-ROM drive. Windows should automatically start the PowerDAQ Setup program. If you see the UEI logo and then the PowerDAQ welcome screen, go to Step 6.
3. If the Setup program does not start automatically, select Run from the Start menu.
4. Enter **d:/setup.exe** in the Open: textbox (substitute the correct drive letter if D is not the one for your CD-ROM drive)

5. Click OK.
6. As the Setup program runs, it will ask you to enter information about your PowerDAQ configuration. Unless you are an expert user and have specific requirements, you should select a typical installation and accept the default configuration.
7. If the Setup program asks for information about third-party software packages that you do not have installed on your PC, leave the text box blank and click the Next button.
8. When the installation is complete, restart your PC when prompted.

Note Never delete the PowerDAQ software from your PC's hard disk directly. Because the installation process modifies the Windows Registry, you must install or uninstall this software only using appropriate programs such as the Uninstall utility in the PowerDAQ folder or the Control Panel/Add-Remove Programs applet.

Linux driver

In order to compile the PowerDAQ kernel module and shared library, you must have a correctly configured Linux kernel source tree. The best way to get one is to download a tarball from kernel.org and compile your own kernel. PowerDAQ works with the 2.2, 2.4 and 2.6 Linux kernels.

At any time you can download the latest Linux driver from our web site www.ueidaq.com. PowerDAQ boards always support the latest Linux driver.

Realtime Linux kernel patches

The PowerDAQ for Linux driver supports hard realtime operation when you augment the base kernel with realtime patches. We have tested our products for operation with the following two patches:

RTAI

If you want to use the realtime capabilities of a PowerDAQ card possible with the RTAI kernel patch, you must first compile and install the RTAI software. Known working versions are RTAI-24.1.4, RTAI-24.1.10, RTAI-24.1.12 and RTAI CVS. Edit the Makefile and set the variable RTAI_DIR to the location of your RTAI installation. Compile the driver with the option RTAI=1.

RTLINUX (FSM Labs)

If you want to use the realtime capabilities of a PowerDAQ card possible with the RTLINUX kernel patch, you must first compile the RTLINUX software (both the kernel and the modules). Known working versions are 2.x and 3.x. Edit the Makefile and set the variable RTLINUX_DIR to the location of your RTLINUX installation. Compile the driver with the option RTL=1 if you use the free version of RTLINUX or RTLPRO=1 if you use the Professional version.

Compiling and installing Linux kernels

Compile using 'make'. Doing so compiles the kernel module, the shared library and the examples.

- To compile the driver for RTLinux, use 'make RTL=1' or 'make RTLPRO=1'
- To compile the driver for RTAI, use 'make RTAI=1'
- To compile the driver for Linux kernel 2.4.x or 2.6.x, use 'make'

Install the resulting driver using 'make install' as root. This installs the files:

```
/lib/modules/⟨⟨kernel version⟩⟩/misc/pwrdaq.o (for kernels 2.4.x)
/lib/modules/⟨⟨kernel version⟩⟩/misc/pwrdaq.ko (for kernels 2.6.x)
/usr/local/lib/libpowerdaq32.so.1.0.
```

Next run the depmode and ldconfig utilities to register those component with your system.

The install script asks if you want to install the library. If you answer Y it then prompts you for the location of LabVIEW on your file system and starts copying the VIs.

Loading and testing the Linux driver

Load the driver using 'modprobe pwrdaq' and test that it detects your boards by issuing the command 'cat /proc/pwrdaq'. That command should list all the PowerDAQ boards it finds on your system.

Note that if you want to install your own IRQ handler under RTLinux or RTAI you must load the driver with the option "rqstirq=0" so that it doesn't install any IRQ handler. When you add this option, the buffered AI/AO/DI/DO functionality is no longer available.

You can now run some examples to test your board:

- SingleAO tests the analog-output subsystem
- SingleDI tests the digital-input subsystem
- SingleDO tests the digital-output subsystem
- SingleUCT tests the counter/timer subsystem

You can set up your system to automatically load the PowerDAQ driver the first time it is needed by adding the following line to the file

```
/etc/modules.conf:
alias char-major-61 pwrdaq
```

Using the PowerDAQ library from C/C++

The best way to start is to take one of the examples Makefile as a template. You must include the following header files in your source code:

```
#include <stdlib.h>
#include <stdint.h>
#include <sys/types.h>
#include <unistd.h>
#include "win_sdk_types.h"
#include "powerdaq.h"
#include "powerdaq32.h"
```

You must also link your application with the PowerDAQ shared library by adding "-lpowerdaq32" to your linker options.

QNX driver

The PowerDAQ QNX driver is compatible with QNX ver 4.x and (6.x up to 6.3).

Compiling and Installing the QNX driver

Compile the driver using 'make'. Doing so compiles the resource manager, the shared library and the examples. To compile the driver with debug output turned on use 'make DEBUG=1'.

Install the QNX driver using 'make install' as root. This installs the files:

```
/usr/lib/libpwrdaq.so.1.0 (the low-level library)
/usr/lib/libpowerdaq32.so.1.0 (the library that interfaces with the resource manager)
/usr/bin/dev-pwrdaq (the resource manager)
```

Loading and testing the QNX driver

Run the resource manager in the background with the command "dev-pwrdaq&".

The resource manager can be started with the following options:

- -h display help
- -i n install interrupt handler if n=1 (default)
- -x n set the transfer mode: 0 = normal, 1 = fast, 2 = DMA (default is 1)
- -p n start the resource manager with priority set to n (0 < n < 40), the default is 20

You can then run some of the examples to test your board:

- SingleAO tests the analog-output subsystem
- SingleDI tests the digital-input subsystem
- SingleDO tests the digital-output subsystem
- SingleUCT tests the counter/timer subsystem

You can set up your system to automatically start the PowerDAQ resource manager. Create or edit the file /etc/rc.d/rc.local.

Add the following line at the end of rc.local: dev-pwrdaq&

Make it executable: "chmod +x /etc/rc/d/rc.local"

Using the QNX library from C/C++

The best way to start working with the QNX driver is to take one of the examples Makefile as a template. You must include the following header files in your source code:

```
#include <stdio.h>
#include <stdint.h>
#include <stdlib.h>
#include <unistd.h>
#include <string.h>

#include "win2qnx.h"
#include "pd_hcaps.h"
#include "powerdaq.h"
#include "lib/powerdaq32.h"
```

You must also link your application with the PowerDAQ shared library by adding "-lpowerdaq32" to your linker options.

Hardware installation

You can install a PD2-AO Series board in any PCI slot and a PDXI-AO Series board in any I/O slot in a Compact PCI / PXI chassis. To install your PowerDAQ board:

1. Turn off your PC.
2. Remove the cover (as appropriate) and make sure you have clear access to the slots.
3. Connect all desired cables that mount directly on the AO Series board (see the section later in this chapter, "Connectors and pinouts" on page 20).
4. Find a free slot and remove any blank brackets that might be there.

TIP

To limit noise interference, install the board as far as possible from other devices and hardware.

5. Insert the PDx-AO Series board into a free slot.

Note

If a slot has not been used in a long time, clean the connector: Insert the PowerDAQ board, immediately remove it and clean its edge connector with alcohol. Then put the board back into the slot.

6. Insert the board and ensure that you have mounted it properly into the slot.
7. Fasten the board's mounting bracket to the PC with the screws that held the blank bracket as appropriate.
8. If necessary, attach a cable to the card's edge connector and also attach it to a termination panel.

CAUTION! When working with a PDXI family card that requires the PDXI-AO-CBL-96, please pay particular attention to the orientation of the cable as shown in Figure 3.1; attaching the cable in the wrong manner can result in damage to the card.

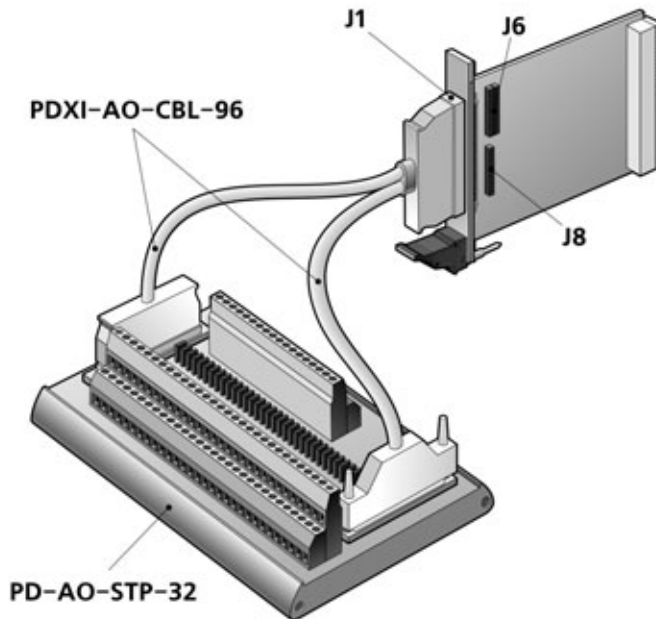

Figure 3.1—Cable layout for PDXI AO boards; J1 connects to the board, whereas the two other ends connect to a screw-terminal panel.

9. Replace the PC's cover if needed
10. Reapply power to the PC.

Base address, DMA and interrupt settings

When you power up your PC, the PCI bus automatically configures any PowerDAQ boards that are installed. You need not set any base address, DMA channels or interrupt levels.

Be aware, though, that performance problems can arise when the system has insufficient interrupts, can't assign a unique one to each peripheral, so a PowerDAQ board must share an interrupt with another device. PowerDAQ boards are designed to share interrupts, but we do not recommend that they do so with devices such as video drivers, network cards, hard disks and especially USB ports. These devices tie up interrupt lines extensively and can significantly delay response to an interrupt from a data-acquisition subsystem. Although Windows NT/2000/XP are not realtime operating systems, your PowerDAQ board is a real-time system within the PC thanks to its own DSP and realtime firmware kernel.

Many motherboard manufacturers allow you to set an IRQ level to a particular PCI slot. If you do not use your PC's serial or parallel ports, you can disable them and use IRQ 3, 4, 5 or 7 for your data-acquisition boards.

Note A data-acq card's interrupt is generally assigned by the PC BIOS, and some PC systems even let you reassign it during the boot process. If your motherboard has an Advanced Interrupt Controller, simply enable it in the BIOS. This allows you to use more than 16 generic interrupt lines. If you don't have this facility, use manual settings to assign the interrupt to the PCI slot where PowerDAQ board is installed

Note Modern motherboards can easily contain five or more PCI slots plus integrated PCI devices such as networking modules and a video driver. Usually only three of these slots are independent and don't share interrupts with these host peripherals. Please refer to your motherboard manual to find out which slots share interrupts and cannot be used for fast data acquisition.

Confirming the installation

In order to confirm the operation of a board you have just installed, run the PowerDAQ Control Panel applet that gets installed along with all other elements of the PowerDAQ SDK. This utility displays all available PowerDAQ boards in your system.

To access the PowerDAQ Control Panel, select **START > Settings > Control Panel** and the PowerDAQ icon is displayed as in Figure 3.2.

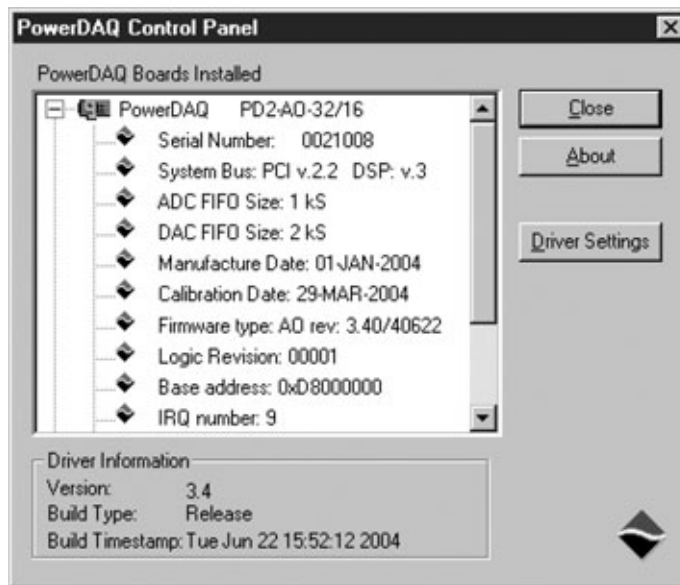

Figure 3.2—PowerDAQ Control Panel applet showing a PD2-AO-32/16 board installed

An alternative test is to use the SimpleTest program installed with the PowerDAQ Software Suite. Attach an oscilloscope or a multimeter to the outputs of the AO board.

Run the **SimpleTest.exe** program by selecting **START > Programs > PowerDAQ > Utilities > SimpleTest**. This program shows all available information about the installed board(s) and allows you to test all subsystems on the selected board. Set the analog outputs to generate signals and verify that the desired signals appear on the DMM or scope display.

Synchronizing multiple boards

In some cases you might wish to synchronize the operation of multiple AO Series cards.

For the PCI-bus PD2 versions, you can make synchronization connections either inside or outside the PC chassis.

For internal connections, note that the J2 connector (described in detail in the section “Connectors and pinouts” on page 20) includes a TMR2 Clock I/O pin. You connect this pin to the TMR2 pin of another board with which you wish to synchronize operation. We recommend you use a 100–200 Ω series resistor for the clock connection between the two cards. If you would like a preconfigured synchronization cable, contact the factory.

For external synchronization, simply make all necessary connections for each card. A common method is to use a PD-CBL-37 cable and a screw-terminal panel for each card. Then simply wire the TMR2 Clock pins of the desired cards together (we still recommend the use of 100–200 Ω series resistors).

Note When synchronizing boards, first ensure that the software driver recognizes them all by examining their status in the PowerDAQ AO Control Panel applet.

For PDXI boards, you can make all synchronization settings over the PXI backplane with the PDXI Configurator software. Alternatively you can use the TMR2 pin on a screw-terminal panel.

Remote sensing

Remote sensing eliminates errors that arise due to voltage drops in the leads connecting the D/A output on the board to the load. When using the sense line the card can achieve 16-bit accuracy at the rated output current. You connect the remote sense line to the load as shown in Figure 3.3.

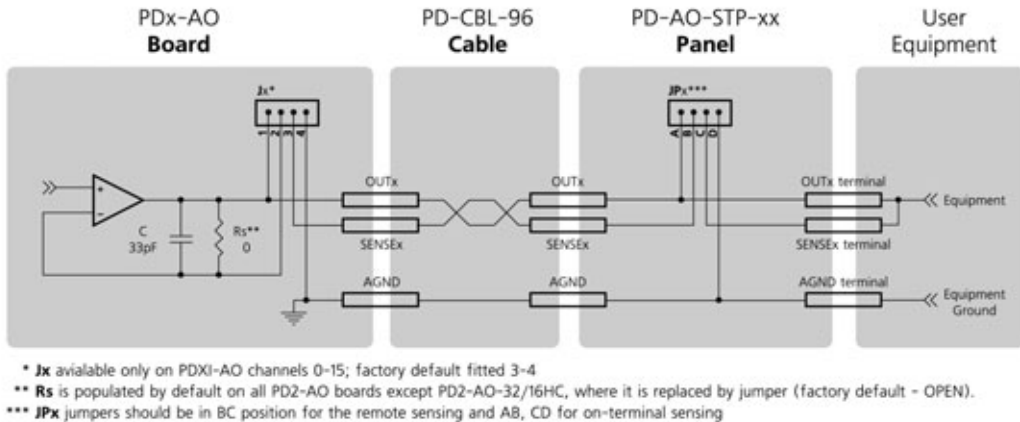

Figure 3.3—Connection of sense lines to a load

An AO Series board reads the feedback voltage on a given channel's sense line and adjusts the output correspondingly to compensate for losses in the leads going to the load. The sense line carries very little current so you needn't be concerned with significant losses in that line.

The various families and products differ in how they implement sensing:

- PD2-AO-8/16, -16/16, -32/16: By default the factory installs sensing resistors (R_s). If the user application requires sense lines, you should be sure to specify that fact when placing your order. With sense resistors populated, you simplify wiring and usually also get lower noise levels on the output. If sense lines are available on the selected board, you should connect them with the corresponding output lines on the PD-AO-STP terminal or at the destination of the output signal
- PD2-AO-32/16HC: Sense lines are standard. If you choose not to take advantage of remote sensing, you should connect the sense lines to the corresponding output lines on the terminal panel or directly on the board using the configuration jumpers that are available for this purpose (a 2-mm jumper per channel, labeled by the channel number on the silkscreen).
- PD2-AO-96/16: This board does not provide sense lines because of the large number of D/As on this high-density board.
- PDXI-AO-8/16, -16/16, -32/16: These cards allows the use of sense lines on at most 16 channels by installing on-board jumpers.

Note The default sense line carries the same signal as the corresponding output on PD2-AO-8/16, -16/16 and -32/16 boards because of noise considerations; large currents going through the cable may force outputs to oscillate because the sense line picks up noise from the surrounding lines.

Connectors and pinouts

PD2-AO-8/16, -16/16 and -32/16

The PCI-bus PD2-AO-8/16, -16/16 and -32/16 boards have two I/O connectors:

- J1: a 96-contact header for analog-output signals
- J2: a 36-way boxed IDC header for digital I/O, counter/timer and interrupt lines

UEI selected a pinout scheme for J1 that allows the PD2-AO-8/16, -16/16 and -32/16 as well as the PD2-MF(S) Series to share common accessories. Note that on PD2-AO-8/16 and -16/16 that the AOut16-AOut31 lines and also the AOut16-AOut31 Sense lines are connected to ground.

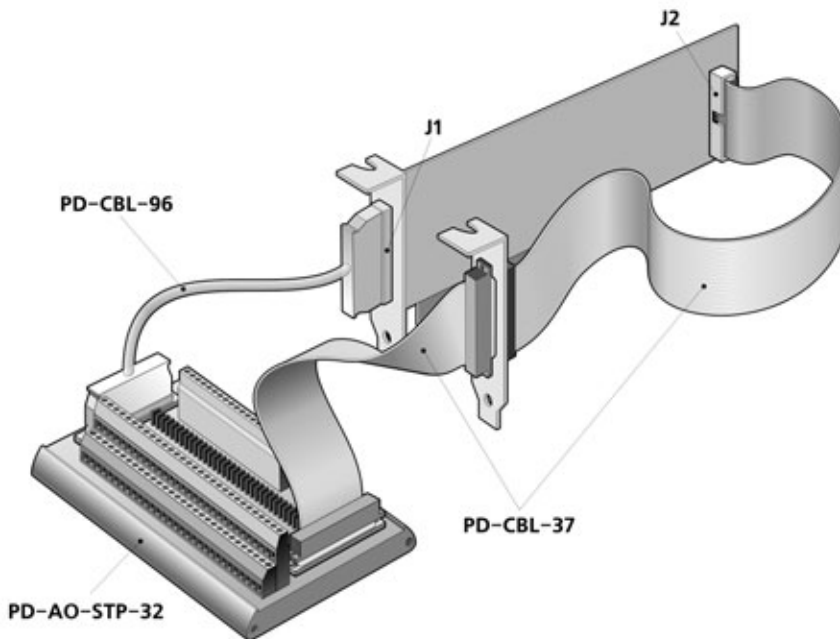

Figure 3.4—Connector layout for the PD2-AO-8/16, -16/16 and -32/16. J1 handles the analog outputs, while J2 carries digital I/O and interrupt signals.

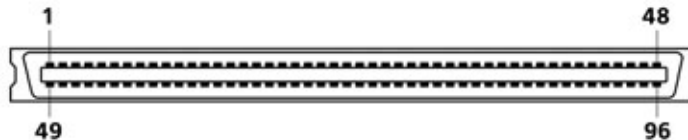

Figure 3.5—Physical layout of J1 on PD2-AO-8/16, -16/16 and -32/16 boards (view looking into the connector as mounted on the board).

| | | | |
|-------------|----|----|-------------|
| AGND | 49 | 1 | AGND |
| NC | 50 | 2 | AGND |
| AGND | 51 | 3 | AGND |
| NC | 52 | 4 | AGND |
| AGND | 53 | 5 | AGND |
| AGND | 54 | 6 | AGND |
| AGND | 55 | 7 | AGND |
| AGND | 56 | 8 | AGND |
| AGND | 57 | 9 | AGND |
| AGND | 58 | 10 | AGND |
| AGND | 59 | 11 | AGND |
| AGND | 60 | 12 | AGND |
| AGND | 61 | 13 | AGND |
| AGND | 62 | 14 | AGND |
| NC | 63 | 15 | AGND |
| NC | 64 | 16 | NC |
| NC | 65 | 17 | NC |
| NC | 66 | 18 | AGND |
| NC | 67 | 19 | NC |
| AOUT7 | 68 | 20 | NC |
| AGND | 69 | 21 | AOUT6 |
| AOUT4 | 70 | 22 | AOUT5 |
| AOUT2 | 71 | 23 | AOUT3 |
| AOUT0 | 72 | 24 | AOUT1 |
| AGND | 73 | 25 | AGND |
| NC | 74 | 26 | AGND |
| AGND | 75 | 27 | NC |
| AGND | 76 | 28 | NC |
| NC | 77 | 29 | AGND |
| AGND | 78 | 30 | AGND |
| AGND | 79 | 31 | AGND |
| AGND | 80 | 32 | AGND |
| AGND | 81 | 33 | AGND |
| AGND | 82 | 34 | AGND |
| AGND | 83 | 35 | AGND |
| AGND | 84 | 36 | AGND |
| AGND | 85 | 37 | AGND |
| AGND | 86 | 38 | AGND |
| NC | 87 | 39 | AGND |
| NC | 88 | 40 | AGND |
| NC | 89 | 41 | NC |
| NC | 90 | 42 | NC |
| AGND | 91 | 43 | NC |
| AOUT7 SENSE | 92 | 44 | NC |
| AOUT5 SENSE | 93 | 45 | AOUT6 SENSE |
| AOUT3 SENSE | 94 | 46 | AOUT4 SENSE |
| AOUT2 SENSE | 95 | 47 | AGND |
| AOUT0 SENSE | 96 | 48 | AOUT1 SENSE |

Figure 3.6—Pin assignments for J1 on the PD2-AO-8/16. This connector handles analog-output signals.

| | | | |
|--------------|----|----|--------------|
| AGND | 49 | 1 | AGND |
| NC | 50 | 2 | AGND |
| AGND | 51 | 3 | AGND |
| NC | 52 | 4 | AGND |
| AGND | 53 | 5 | AGND |
| AGND | 54 | 6 | AGND |
| AGND | 55 | 7 | AGND |
| AGND | 56 | 8 | AGND |
| AGND | 57 | 9 | AGND |
| AGND | 58 | 10 | AGND |
| AGND | 59 | 11 | AGND |
| AGND | 60 | 12 | AGND |
| AGND | 61 | 13 | AGND |
| AGND | 62 | 14 | AGND |
| NC | 63 | 15 | AGND |
| AOUT14 | 64 | 16 | AOUT15 |
| AOUT12 | 65 | 17 | AOUT13 |
| AOUT11 | 66 | 18 | AGND |
| AOUT9 | 67 | 19 | AOUT10 |
| AOUT7 | 68 | 20 | AOUT8 |
| AGND | 69 | 21 | AOUT6 |
| AOUT4 | 70 | 22 | AOUT5 |
| AOUT2 | 71 | 23 | AOUT3 |
| AOUT0 | 72 | 24 | AOUT1 |
| AGND | 73 | 25 | AGND |
| NC | 74 | 26 | AGND |
| AGND | 75 | 27 | NC |
| AGND | 76 | 28 | NC |
| NC | 77 | 29 | AGND |
| AGND | 78 | 30 | AGND |
| AGND | 79 | 31 | AGND |
| AGND | 80 | 32 | AGND |
| AGND | 81 | 33 | AGND |
| AGND | 82 | 34 | AGND |
| AGND | 83 | 35 | AGND |
| AGND | 84 | 36 | AGND |
| AGND | 85 | 37 | AGND |
| AGND | 86 | 38 | AGND |
| AOUT15 SENSE | 87 | 39 | AGND |
| AOUT14 SENSE | 88 | 40 | AGND |
| AOUT12 SENSE | 89 | 41 | AOUT13 SENSE |
| AOUT10 SENSE | 90 | 42 | AOUT11 SENSE |
| AGND | 91 | 43 | AOUT9 SENSE |
| AOUT7 SENSE | 92 | 44 | AOUT8 SENSE |
| AOUT5 SENSE | 93 | 45 | AOUT6 SENSE |
| AOUT3 SENSE | 94 | 46 | AOUT4 SENSE |
| AOUT2 SENSE | 95 | 47 | AGND |
| AOUT0 SENSE | 96 | 48 | AOUT1 SENSE |

Figure 3.7— Pin assignments for J1 on the PD2-AO-16/16. This connector handles analog output signals.

| | | | |
|--------------|----|----|--------------|
| AGND | 49 | 1 | AGND |
| AGND | 50 | 2 | AGND |
| AGND | 51 | 3 | AGND |
| AGND | 52 | 4 | AGND |
| AGND | 53 | 5 | NC |
| AGND | 54 | 6 | AGND |
| AOUT30 | 55 | 7 | AOUT31 |
| AOUT28 | 56 | 8 | AOUT29 |
| AOUT26 | 57 | 9 | AOUT27 |
| AOUT24 | 58 | 10 | AOUT25 |
| AOUT23 | 59 | 11 | AGND |
| AOUT21 | 60 | 12 | AOUT22 |
| AOUT19 | 61 | 13 | AOUT20 |
| AGND | 62 | 14 | AOUT18 |
| AOUT16 | 63 | 15 | AOUT17 |
| AOUT14 | 64 | 16 | AOUT15 |
| AOUT12 | 65 | 17 | AOUT13 |
| AOUT11 | 66 | 18 | AGND |
| AOUT9 | 67 | 19 | AOUT10 |
| AOUT7 | 68 | 20 | AOUT8 |
| AGND | 69 | 21 | AOUT6 |
| AOUT4 | 70 | 22 | AOUT5 |
| AOUT2 | 71 | 23 | AOUT3 |
| AOUT0 | 72 | 24 | AOUT1 |
| AGND | 73 | 25 | AGND |
| AGND | 74 | 26 | AGND |
| AGND | 75 | 27 | AGND |
| AGND | 76 | 28 | AGND |
| AGND | 77 | 29 | AGND |
| AOUT31 SENSE | 78 | 30 | AGND |
| AOUT29 SENSE | 79 | 31 | AOUT30 SENSE |
| AGND | 80 | 32 | AOUT28 SENSE |
| AOUT26 SENSE | 81 | 33 | AOUT27 SENSE |
| AOUT24 SENSE | 82 | 34 | AOUT25 SENSE |
| AOUT22 SENSE | 83 | 35 | AOUT23 SENSE |
| AOUT21 SENSE | 84 | 36 | AGND |
| AOUT19 SENSE | 85 | 37 | AOUT20 SENSE |
| AOUT17 SENSE | 86 | 38 | AOUT18 SENSE |
| AOUT15 SENSE | 87 | 39 | AOUT16 SENSE |
| AOUT14 SENSE | 88 | 40 | AGND |
| AOUT12 SENSE | 89 | 41 | AOUT13 SENSE |
| AOUT10 SENSE | 90 | 42 | AOUT11 SENSE |
| AGND | 91 | 43 | AOUT9 SENSE |
| AOUT7 SENSE | 92 | 44 | AOUT8 SENSE |
| AOUT5 SENSE | 93 | 45 | AOUT6 SENSE |
| AOUT3 SENSE | 94 | 46 | AOUT4 SENSE |
| AOUT2 SENSE | 95 | 47 | AGND |
| AOUT0 SENSE | 96 | 48 | AOUT1 SENSE |

Figure 3.8— Pin assignments for J1 on the PD2-AO-32/16. This connector handles analog output signals.

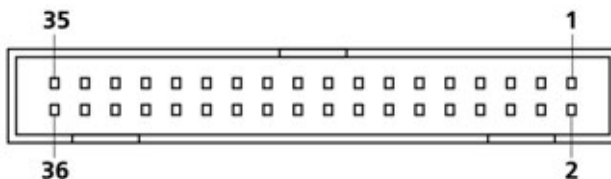

Figure 3.9—Physical layout of J2 on PD2-AO-8/16, -16/16 and -32 boards (view looking into the connector as mounted on the board).

| | | | |
|------|----|----|--------|
| DGND | 1 | 2 | DGND |
| TMR0 | 3 | 4 | TMR2 |
| DGND | 5 | 6 | DGND |
| DGND | 7 | 8 | DGND |
| TMR1 | 9 | 10 | +5VPJ2 |
| DIN0 | 11 | 12 | DGND |
| DIN1 | 13 | 14 | DOUT0 |
| DIN2 | 15 | 16 | DOUT1 |
| DIN3 | 17 | 18 | DOUT2 |
| DIN4 | 19 | 20 | DOUT3 |
| DIN5 | 21 | 22 | DOUT4 |
| DIN6 | 23 | 24 | DOUT5 |
| DIN7 | 25 | 26 | DOUT6 |
| IRQA | 27 | 28 | DOUT7 |
| IRQB | 29 | 30 | DGND |
| IRQC | 31 | 32 | DGND |
| DGND | 33 | 34 | DGND |
| DGND | 35 | 36 | DGND |

Figure 3.10—Pin assignments for J2 on the PD2-AO-8/16, -16/16 and -32/16. This connector handles digital I/O, timers and interrupt lines.

PD2-AO-32/16HC

The high-current -HC version uses a daughtercard approach to hold the extra circuitry needed for large output currents. The J5 and J6 connectors mate when you put the cards together. The J1 connector, which has the same pinouts as the standard PD2-AO-32/16, again carries the analog outputs, and the J2 connector again carries the digital lines.

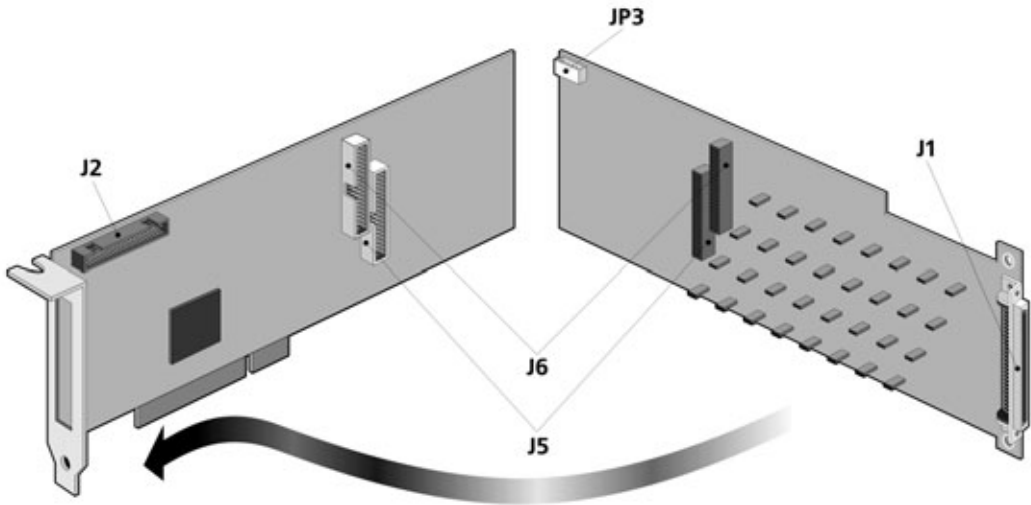

Figure 3.11—Connectors for PD2-AO-32/16HC. With the 32 2-mm jumpers on the right-hand board you connect the force-sense lines on the corresponding analog outputs (the channel numbers are marked on the pc-board silkscreen). The default position is Open, in which case you should connect force-sense lines on the terminal panel or at the destination of the analog output.

PD2-AO-96/16

Because of its high density with 96 independent analog outputs, the PowerDAQ PD2-AO-96/16 board has seven headers (note that there is no J1, which on some AO Series boards is a bracket-mounted connector)

- J2: 36-way boxed IDC header for digital I/O, counter/timer and interrupt lines
- J3: 40-way boxed IDC header for AO Port0 (outputs 0-15)
- J4: 40-way boxed IDC header for AO Port1 (outputs 16-31)
- J5: 40-way boxed IDC header for AO Port2 (outputs 32-47)
- J6: 40-way boxed IDC header for AO Port3 (outputs 48-63)
- J7: 40-way boxed IDC header for AO Port4 (outputs 64-79)
- J8: 40-way boxed IDC header for AO Port5 (outputs 80-95)

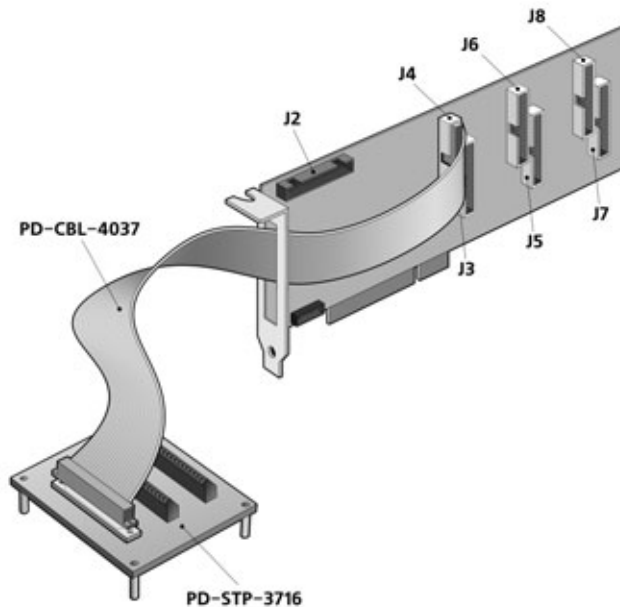

Figure 3.12—Connectors for PD2-AO-96/16. For each connector J3 through J8 you need a separate PD-CBL-4037/PD-STP-3716 assembly, and the cables all snake through the opening in the mounting bracket. Similarly, separate panels are needed if you want access to the digital I/O lines through J2.

PD2-AO-96/16

On the PD2-AO-96/16, the J2 connector, which handles digital I/O, timers and interrupts, has a similar pinout as on other members of the PD2-AO family (see Figure 3.10).

For its analog-output signals, the PD2-AO-96/16 differs from other members of the AO Series in that it does not use a bracket-mounted connector. Instead, it supplies six on-board connectors (J3-J8). They all share the same pinout except for J3, which also has lines for clocking and triggering.

| | | | |
|------------|----|----|--------|
| NC | 1 | 2 | NC |
| DGND | 3 | 4 | DGND |
| TMR0 | 5 | 6 | TMR2 |
| DGND | 7 | 8 | DGND |
| DGND | 9 | 10 | DGND |
| TMR1 | 11 | 12 | +5VPJ2 |
| DIN0 | 13 | 14 | DGND |
| DIN1 | 15 | 16 | DOUT0 |
| DIN2 | 17 | 18 | DOUT1 |
| DIN3 | 19 | 20 | DOUT2 |
| DIN4 | 21 | 22 | DOUT3 |
| DIN5 | 23 | 24 | DOUT4 |
| DIN6 | 25 | 26 | DOUT5 |
| DIN7 | 27 | 28 | DOUT6 |
| EXT GATEIN | 29 | 30 | DOUT7 |
| EXT CLKIN | 31 | 32 | DGND |
| EXT TRIGIN | 33 | 34 | DGND |
| DGND | 35 | 36 | DGND |
| DGND | 37 | 38 | DGND |
| NC | 39 | 40 | NC |

Figure 3.13—Pin assignments for J2 on the PD2-AO-96/16.

| | | | | | | | |
|------------|----|----|-----------|--------|----|----|------|
| CLOCK IN | 1 | 2 | CLOCK OUT | N/C | 1 | 2 | N/C |
| TRIGGER IN | 3 | 4 | GATE IN | N/C | 3 | 4 | N/C |
| DGND | 5 | 6 | AGND | DGND | 5 | 6 | AGND |
| AOUT0 | 7 | 8 | AGND | AOUT16 | 7 | 8 | AGND |
| AOUT1 | 9 | 10 | AGND | AOUT17 | 9 | 10 | AGND |
| AOUT2 | 11 | 12 | AGND | AOUT18 | 11 | 12 | AGND |
| AOUT3 | 13 | 14 | AGND | AOUT19 | 13 | 14 | AGND |
| AOUT4 | 15 | 16 | AGND | AOUT20 | 15 | 16 | AGND |
| AOUT5 | 17 | 18 | AGND | AOUT21 | 17 | 18 | AGND |
| AOUT6 | 19 | 20 | AGND | AOUT22 | 19 | 20 | AGND |
| AOUT7 | 21 | 22 | AGND | AOUT23 | 21 | 22 | AGND |
| AOUT8 | 23 | 24 | AGND | AOUT24 | 23 | 24 | AGND |
| AOUT9 | 25 | 26 | AGND | AOUT25 | 25 | 26 | AGND |
| AOUT10 | 27 | 28 | AGND | AOUT26 | 27 | 28 | AGND |
| AOUT11 | 29 | 30 | AGND | AOUT27 | 29 | 30 | AGND |
| AOUT12 | 31 | 32 | AGND | AOUT28 | 31 | 32 | AGND |
| AOUT13 | 33 | 34 | AGND | AOUT29 | 33 | 34 | AGND |
| AOUT14 | 35 | 36 | AGND | AOUT30 | 35 | 36 | AGND |
| AOUT15 | 37 | 38 | N/C | AOUT31 | 37 | 38 | N/C |
| N/C | 39 | 40 | N/C | N/C | 39 | 40 | N/C |

Figure 3.14—Pin assignments on the PD2-AO-96/16 for J3 (left) and J4-J8 (right). These connectors handle analog-output signals on this high-density card. The pinouts on J4-J8 all follow a similar pattern and thus are not reproduced in this diagram.

Panel connection, PD2

The following example illustrates how to connect a PD2-AO board to the PD-AO-STP-32 screw-terminal panel.

Note For the PD2-AO-8/16 and -16/16 boards, signal lines OUT16 to OUT31 and OUT16S to OUT32S are tied to analog ground.

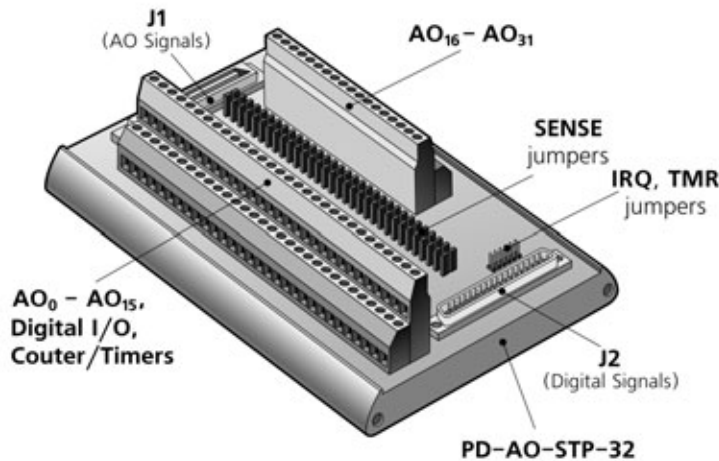

Figure 3.15—Configuring the PD-AO-STP screw-terminal panel for use with the PD2-AO-8/16, -16/16 and -32/16.

As shown in Figure 3.15, you bring analog signals to the termination panel through the PD-CBL-96 cable using J1, whereas digital signals come to the panel through the PD-CBL-37 cable on J2. On the analog-output terminals, AOUT_x is the output for Ch *x*; SNS_x is the sense line for Ch *x*, or it serves as an analog ground, depending on how you set the sense jumpers JP1-JP32 located on the middle of the panel. The positions A, B, C and D are marked on the panel. If you install a shunt across positions B-C, the channel is configured for remote sensing and you then use the SNS_x terminal to connect that line to the remote equipment. If you install shunts across positions A-B and C-D, the channel is configured for local sensing at the termination panel, and you then use a channel's SNS_x terminal to make a connection to analog ground.

A local sense line is used with most applications where current drive from the board is < 1 mA or where the user application can ignore the voltage drop across the cable. For details on the advantages of sense lines along with when and how to use them, refer to the section "

Remote sensing" on page 19.

PDXI-AO-8/16, -16/16, -32/16

The PXI-bus PowerDAQ PDXI-AO-8/16, -16/16 and -32/16 boards have only one connector, J1. This 96-contact header handles all analog outputs as well as digital I/O and counter/timer signals. In order to keep digital noise level extremely low, UEI supplies a special Y-cable (Model PDXI-AO-CBL-96) that plugs into the J1 connector and immediately splits into two other cables, thus separating analog and digital signals for distribution to the screw-terminal panel.

CAUTION! Be sure to use the PDXI-AO-CBL-96, which is designed specifically for this board. Do NOT use other UEI cables such as the PD2-CBL-96 (a single cable that does not have the "Y" split), even though they might fit onto the J1 connector. Their use on a PDXI-AO board could result in damage to the D/A converters.

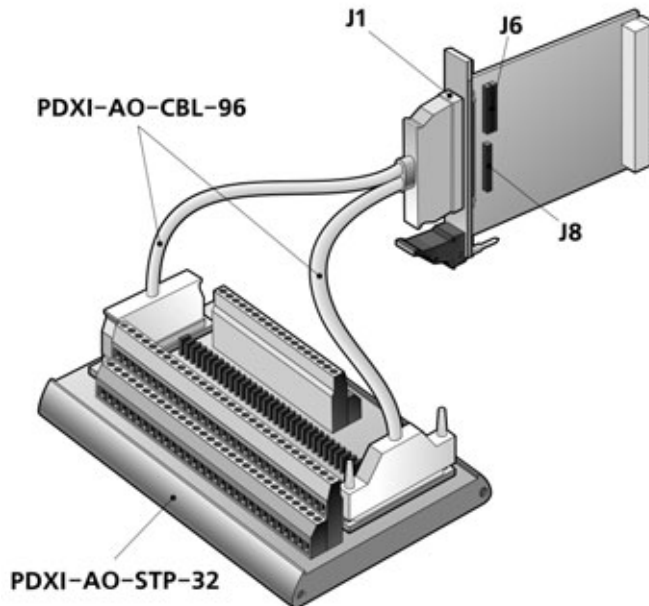

Figure 3.16a—Connectors for PDXI-AO-8/16, -16/16 and -32/16. J1 handles all analog and digital signals. Jumper block J6 allows you to set the sense lines, and jumper block J8 offers a means of grounding unused analog-output channels. (see also Figure 3.1)

| | | | |
|--------------|----|----|----------|
| AOUT3 SENSE | 1 | 49 | AOUT3 |
| AOUT2 SENSE | 2 | 50 | AOUT2 |
| AOUT1 SENSE | 3 | 51 | AOUT1 |
| AOUT0 SENSE | 4 | 52 | AOUT0 |
| AGND2 | 5 | 53 | AGND1 |
| AOUT7 SENSE | 6 | 54 | AOUT7 |
| AOUT6 SENSE | 7 | 55 | AOUT6 |
| AOUT5 SENSE | 8 | 56 | AOUT5 |
| AOUT4 SENSE | 9 | 57 | AOUT4 |
| AGND4 | 10 | 58 | AGND3 |
| AOUT11 SENSE | 11 | 59 | AOUT11 |
| AOUT10 SENSE | 12 | 60 | AOUT10 |
| AOUT9 SENSE | 13 | 61 | AOUT9 |
| AOUT8 SENSE | 14 | 62 | AOUT8 |
| AGND6 | 15 | 63 | AGND5 |
| AOUT15 SENSE | 16 | 64 | AOUT15 |
| AOUT14 SENSE | 17 | 65 | AOUT14 |
| AOUT13 SENSE | 18 | 66 | AOUT13 |
| AOUT12 SENSE | 19 | 67 | AOUT12 |
| AGND7 | 20 | 68 | AOUT16 |
| AGND8 | 21 | 69 | AOUT17 |
| AGND9 | 22 | 70 | AOUT18 |
| AGND10 | 23 | 71 | AOUT19 |
| AGND11 | 24 | 72 | AOUT20 |
| AGND12 | 25 | 73 | AOUT21 |
| AGND13 | 26 | 74 | AOUT22 |
| AGND14 | 27 | 75 | AOUT23 |
| AGND15 | 28 | 76 | AOUT24 |
| AGND16 | 29 | 77 | AOUT25 |
| AGND17 | 30 | 78 | AOUT26 |
| AGND18 | 31 | 79 | AOUT27 |
| AGND19 | 32 | 80 | AOUT28 |
| AGND20 | 33 | 81 | AOUT29 |
| AGND21 | 34 | 82 | AOUT30 |
| AGND22 | 35 | 83 | AOUT31 |
| DGND2 | 36 | 84 | DGND1 |
| EXT CMD | 37 | 85 | EXT TRIG |
| TMR2 | 38 | 86 | EXT CLK |
| TMR1 | 39 | 87 | TMR0 |
| DGND4 | 40 | 88 | DGND3 |
| DOUT0 | 41 | 89 | DIN0 |
| DOUT1 | 42 | 90 | DIN1 |
| DOUT2 | 43 | 91 | DIN2 |
| DOUT3 | 44 | 92 | DIN3 |
| DOUT4 | 45 | 93 | DIN4 |
| DOUT5 | 46 | 94 | DIN5 |
| DOUT6 | 47 | 96 | DIN6 |
| DOUT7 | 48 | 96 | DIN7 |

Figure 3.16b—Pinout assignments on J1 of PDXI-AO-CBL-96 cable. Note that this same cable operates with 8-, 16- or 32-channel boards, but the overall pinout configuration stays the same and the other lines in the cable are not used.

| | | | |
|----------|----|----|-------|
| DGND1 | 1 | 20 | NC |
| TMR0 | 2 | 21 | TMR2 |
| NC | 3 | 22 | NCD |
| NC | 4 | 23 | DGND2 |
| TMR1 | 5 | 24 | NC |
| DIN0 | 6 | 25 | DGND3 |
| DIN1 | 7 | 26 | DOUT0 |
| DIN2 | 8 | 27 | DOUT1 |
| DIN3 | 9 | 28 | DOUT2 |
| DIN4 | 10 | 29 | DOUT3 |
| DIN5 | 11 | 30 | DOUT4 |
| DIN6 | 12 | 31 | DOUT5 |
| DIN7 | 13 | 32 | DOUT6 |
| EXT TRIG | 14 | 33 | DOUT7 |
| EXT CMD | 15 | 34 | NC |
| EXT CLK | 16 | 35 | DGND4 |
| NC | 17 | 36 | NC |
| NC | 18 | 37 | NC |
| NC | 19 | | |

Figure 3.16c—Pinout assignments on J2 of PDXI-AO-CBL-96 cable.

| | | | |
|--------------|----|----|--------------|
| NC | 1 | 49 | NC |
| NC | 2 | 50 | NC |
| NC | 3 | 51 | NC |
| AGND1 | 4 | 52 | NC |
| NC | 5 | 53 | AGND2 |
| NC | 6 | 54 | AGND3 |
| AOUT31 | 7 | 55 | AOUT30 |
| AOUT29 | 8 | 56 | AOUT28 |
| AOUT27 | 9 | 57 | AOUT26 |
| AOUT25 | 10 | 58 | AOUT24 |
| AGND4 | 11 | 59 | AOUT23 |
| AOUT22 | 12 | 60 | AOUT21 |
| AOUT20 | 13 | 61 | AOUT19 |
| AOUT18 | 14 | 62 | AGND5 |
| AOUT17 | 15 | 63 | AOUT16 |
| AOUT15 | 16 | 64 | AOUT14 |
| AOUT13 | 17 | 65 | AOUT12 |
| AGND6 | 18 | 66 | AOUT11 |
| AOUT10 | 19 | 67 | AOUT9 |
| AOUT8 | 20 | 68 | AOUT7 |
| AOUT6 | 21 | 69 | AGND7 |
| AOUT5 | 22 | 70 | AOUT4 |
| AOUT3 | 23 | 71 | AOUT2 |
| AOUT1 | 24 | 72 | AOUT0 |
| AGND9 | 25 | 73 | AGND8 |
| AGND11 | 26 | 74 | AGND10 |
| AGND13 | 27 | 75 | AGND12 |
| AGND15 | 28 | 76 | AGND14 |
| AGND17 | 29 | 77 | AGND16 |
| AGND18 | 30 | 78 | NC |
| NC | 31 | 79 | NC |
| NC | 32 | 80 | AGND19 |
| NC | 33 | 81 | NC |
| NC | 34 | 82 | NC |
| NC | 35 | 83 | NC |
| AGND20 | 36 | 84 | NC |
| NC | 37 | 85 | NC |
| NC | 38 | 86 | NC |
| NC | 39 | 87 | AOUT15 SENSE |
| NC | 40 | 88 | AOUT14 SENSE |
| AOUT13 SENSE | 41 | 89 | AOUT12 SENSE |
| AOUT11 SENSE | 42 | 90 | AOUT10 SENSE |
| AOUT9 SENSE | 43 | 91 | AGND21 |
| AOUT8 SENSE | 44 | 92 | AOUT7 SENSE |
| AOUT6 SENSE | 45 | 93 | AOUT5 SENSE |
| AOUT4 SENSE | 46 | 94 | AOUT3 SENSE |
| AGND22 | 47 | 96 | AOUT2 SENSE |
| AOUT1 SENSE | 48 | 96 | AOUT0 SENSE |

Figure 3.16d—Pinout assignments on J3 of PDXI-AO-CBL-96 cable.

Referring again to Figure 3.16a, the jumper block J6 at the top of the card configures sense lines for either local or remote sensing. For details on the advantages of sense lines along with when and how to use them, refer to the section “

Remote sensing” on page 19. J8 provides jumpers that allow you to ground unused channels.

Example: To configure AOut 0-15 for local sense on the board, install a jumper across terminals 1 and 2 and also across terminals 3 and 4. In this case, also ground the SNSx terminals (where x is the output channel number). When using local sense, you should also install sense jumpers on the PDXI-AO-STP panel in the B-C position.

Example: If you want to keep sense lines in the cable active (using the remote sense mode), place a jumper across terminals 2 and 3 on the board. On the PDXI-AO-STP terminal panel you should also install jumpers as follows: across positions A-B and C-D if the sense lines are connected to the corresponding output lines on the screw-terminal panel (local sensing), or in position B-C if the sense lines are connected at the destination of the output signal (remote sensing).

The sense line jumper rows on the PDXI-AO boards are marked as follows:

| | | | |
|----------|----------|----------|----------|
| A-AOut3 | B-AOut2 | C-AOut1 | D-AOut0, |
| E-AOut7 | F-AOut6 | G-AOut5 | H-AOut4, |
| I-AOut11 | J-AOut10 | K-AOut9 | L-AOut8, |
| M-AOut15 | N-AOut14 | O-AOut13 | P-AOut12 |

Table 3.1—Sense-line jumpers on PDXI AO boards

On the PDXI-AO-8/16 and PDXI-AO-16/16 card you want to keep the unused 16 analog lines from floating. Thus the jumper block at the bottom of the card (J8) provides factory-installed jumpers that connect outputs 16-31 to analog ground, thereby providing more grounds in the external connection cable.

In wiring PDXI-AO cards to a screw-terminal panel, note that all models use the same J1 edge connector as shown in Figure 3.1. The cable then splits the signals up at the panel

Panel connection, PDXI

The following section explains how to connect a PDXI-AO board to the PDXI-AO-STP-32 screw-terminal panel

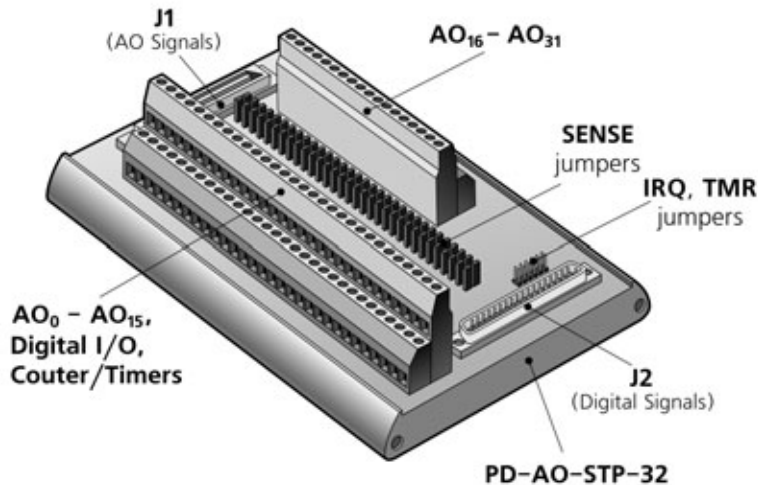

Figure 3.17—Configuring the PD-AO-STP-32 screw-terminal panel for use with the PDXI-AO-8/16, -16/16 and -32/16 boards. Note that the IRQ and TMR jumpers are not used with the AO boards.

As shown in Figure 3.17, you bring both analog and digital signals to the termination panel through the PDXI-AO-CBL cable, which splits into two and thus makes connections to both J1 and J2. On the analog-output terminals, AOUT_x is the output for Ch *x*; SNS_x is the sense line for Ch *x*, or it serves as an analog ground, depending on how you set the sense jumpers JP1-JP32 on the panel using the positions A, B, C and D as marked there.

On the Local/Remote Sense jumpers you should install the Sense-to-Out jumpers (JP0-JP15) on the panel only if you have set the jumpers on J6 on the PDXI-AO board across positions 2-3. Jumpers JP16 to JP31 should NEVER be installed.

4. Architecture

Functional Overview

This chapter describes the functional operation of the PowerDAQ AO Series boards. These cards provide extensive analog-output options, digital I/O, counter/timers and simultaneous operation of all subsystems.

The heart of each board is a Motorola 56301, a 24-bit DSP running at 66 MHz (100 MHz on -HS models). That device incorporates a highly efficient interface with the PCI/PXI bus. That interface implements the PCI Local Bus Specifications so the board is fully auto-configured (for base address, interrupt). The DSP also provides control over all board subsystems.

When you power up the system and load the PowerDAQ software, it immediately downloads operating firmware to the DSP on the card over the PCI bus. This firmware contains all the code necessary for an application program to communicate with the host PC driver and through it all board subsystems.

Note The drivers on the UEI web site (www.ueidaq.com) always contain the latest versions of the DSP firmware.

Note Custom programming of the DSP is not an option with standard PowerDAQ AO boards. Should you require special functions on the DSP, please contact the factory for information about our consulting services for such tasks.

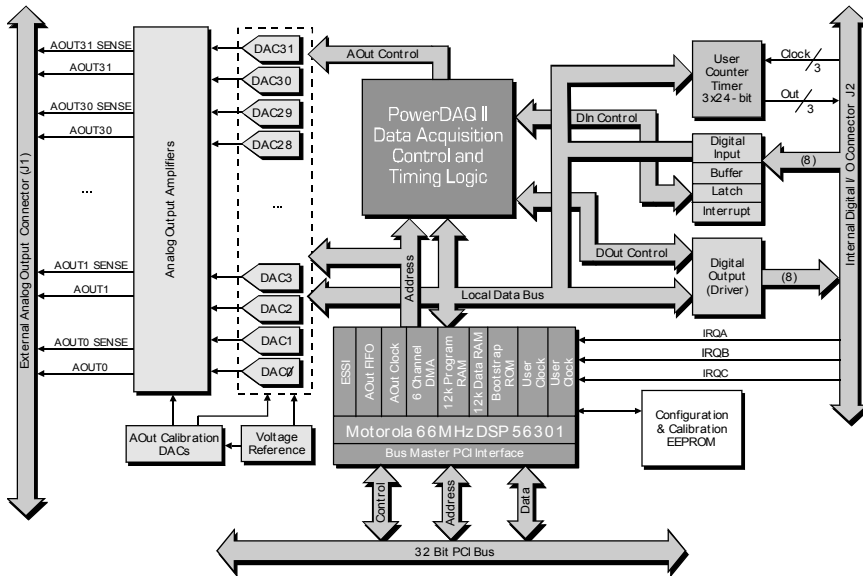

Figure 4.1—Block diagram of PowerDAQ PD2-AO-8/16, -16/16 and -32/16 boards

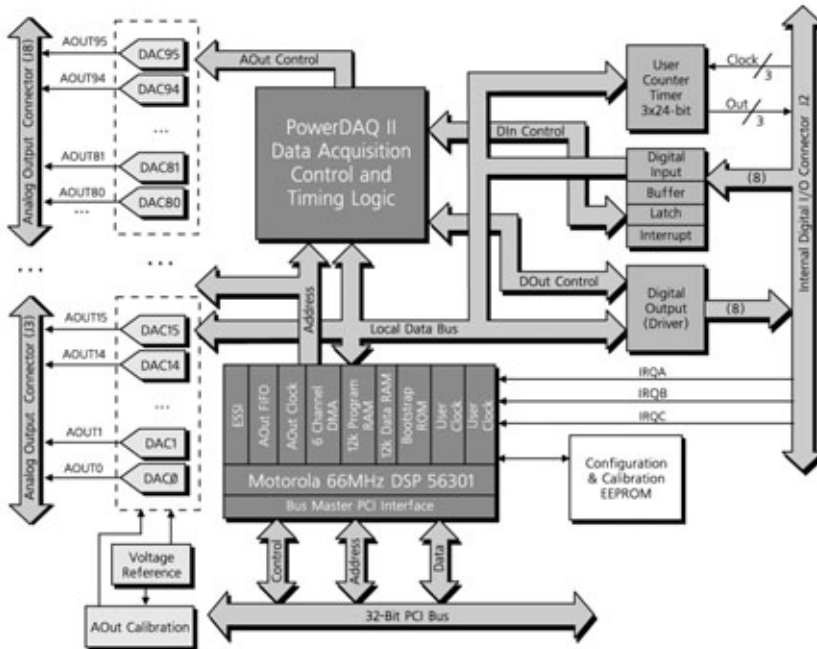

Figure 4.2—Block diagram of PowerDAQ PD2-AO-96/16 board

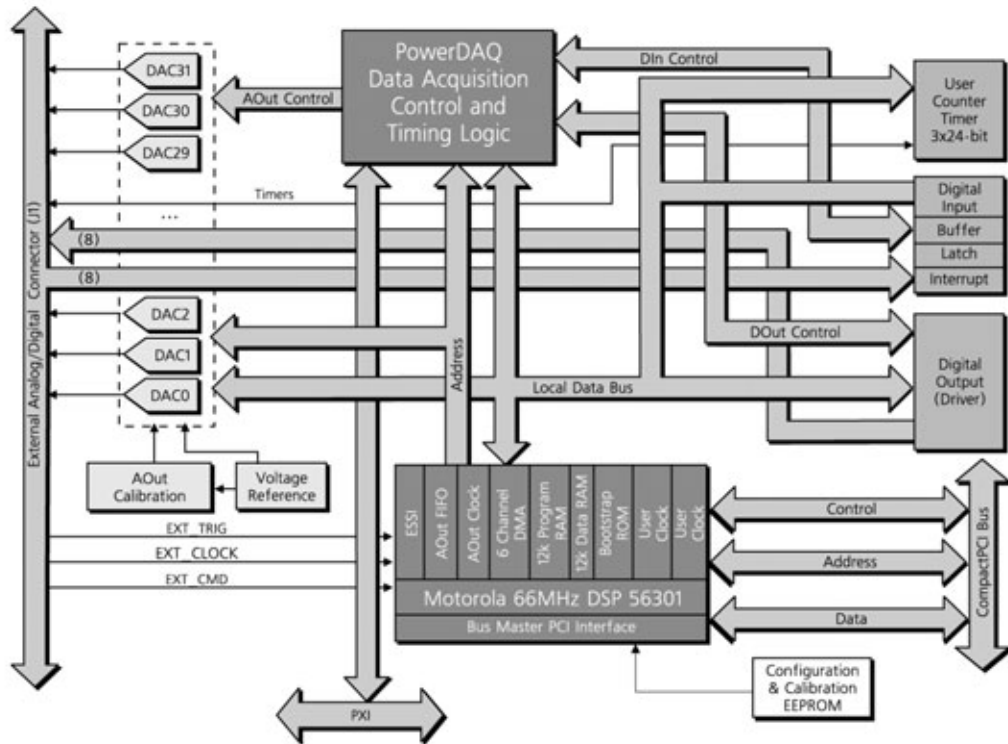

Figure 4.3—Block diagram of PowerDAQ PDXI-AO boards

The Analog Output subsystem

The AO subsystem (see details in Chapter 5) includes these features:

- 2k-sample standard DSP D/A FIFO with optional 64k-sample memory upgrade (64k samples standard on -HS models)
- Either 8, 16, 32 or 96 independent D/As that convert digitized waveform values into analog voltages. Each D/A can run at a different rate, using different source data supplied from a common datastream shared among all channels
- A calibration D/A subsystem that provides voltages to adjust offset and gain on the analog output to ensure accurate performance.
- Timing, triggering and clocking controls that allow you to select the analog-output rate and clock source.
- For high-speed analog-output applications, UEI offers the PDx-AO-HS. This high-speed waveform generator comes with as many as 96 output channels. These boards can generate 100k samples/sec (when the output settles to 16 bits) or 200k samples/sec (when the output settles to 11-12 bits) per channel on all channels simultaneously using the onboard DSP memory in Waveform Regenerate or Single-Point Update modes. HS boards feature a 100-MHz DSP and come standard with

64k samples of memory. Further, the PD2-AO-96/16HS specs an aggregate update rate of 9.6M samples/sec when outputting from on-board memory.

- The output drive per channel on a standard PD2-AO Series board is 20 mA, on the PDXI-AO Series and PD2-AO-96 board it is 5 mA. UEI also offers -HC versions that increase per-channel drive up to 100 mA continuous.
- The output level of the D/As on AO Series boards is $\pm 10V$. However, UEI also offers an accessory, the PD-AO-AMP-100, an external 16-channel amplifier. When used with any AO board, it provides an output range of up to $\pm 100V$ (with individual gains of 2, 10 or 20 per channel).

Note Custom ranges are available; contact UEI sales department for availability. At this time, we offer $\pm 2.5V$, $\pm 5V$ -10-0V and 0-10V configurations on special order.

- An interrupt mechanism that notifies the DSP and sends an interrupt over the PCI bus on special conditions so the user application can take appropriate action
- Direct access to the on-board output FIFO memory for advanced applications

The Digital I/O subsystem

The Digital I/O subsystem (static I/O, see details in Chapter 6) includes these features:

- An 8-bit register to read logic levels on digital input lines
- An 8-bit register to hold logic levels on digital output lines once the program has written data to the outputs
- An interrupt mechanism that notifies the DSP of special conditions on this subsystem so the user application can take appropriate action
- The digital outputs can interface directly to 3V electromechanical or solid-state relays

Counter/timer subsystem

(see details in Chapter 7) Depending on its operating mode, a PowerDAQ AO board can support as many as three DSP-based 24-bit counter/timers with a maximum count rate of 33 MHz (50 MHz on -HS models) on the internal clock or 16.5 MHz (25 MHz on -HS models) for an external clock. There is no lower limit for the minimum count rate (but that clock does require a relatively sharp rising/falling edge, no longer than 1 μsec).



TMR2 is used in the AO Buffered mode so in that case you no longer have access to all three counter/timers on the DSP.

Interrupt lines

The DSP56301 is a powerful processor using an advanced Harvard architecture. One of its features consists of four high-speed external interrupt lines, a feature that these boards pass along to PowerDAQ users.

TIP

Three interrupt lines, called IRQA, IRQB and IRQC, are available on the J2 connector and are used for synchronization purposes; they also act as a part of the initial system boot process. Those lines must be properly pulled up or down (or left unconnected / tristated) during the system bootup sequence. They must meet the following conditions to allow your PC to boot properly. When the IRQ lines are used on the PowerDAQ board: IRQA = 1, IRQB = 0, IRQC = 0. The PC will not boot if the IRQx lines are used but are not in the proper state during the bootup process.

Programming Model

No matter which subsystem you choose to work with, the way you initialize and set up the board is very much the same, so before digging into details of individual subsystems it makes sense to review these general procedures.

An onboard DSP controls all subsystems. User applications communicate with the board via the PowerDAQ API, which (in the case of Windows) is integrated into the PowerDAQ dynamic-link library (DLL). The API provides a uniform set of calls across all supported operating systems. To inform an application about hardware events, the driver creates kernel events. Data is transferred from the user-level buffer to the board through the PCI bus either directly to the DAC or in 1k to 32k-sample blocks in Buffered mode (block size depends on the FIFO size). The PowerDAQ API includes a set of information functions that allow user applications to get board-specific information such as model, serial number and IRQ line.

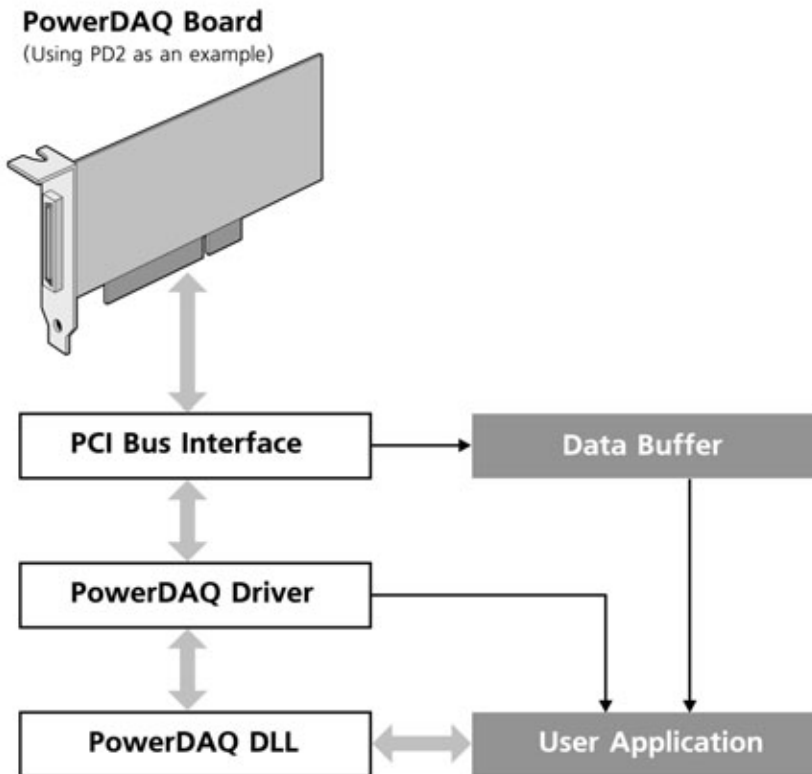

Figure 4.4—Communication between a user application and a PowerDAQ AO board

Modes and performance

All PowerDAQ subsystems have two modes of operation:

- Polled—in this mode, the user application queries the board about the status of various subsystems as needed. This method is preferred when the application does not need to be notified about hardware events.
- Event-based—in this mode, the board notifies the user application of certain predefined subsystem events using OS calls, thereby allowing you to write truly asynchronous applications.

As applied specifically to the AO Series boards, we offer the following modes:

- **Single-Point Update mode**
In this mode, you can update the analog output of each channel independently. The update is performed immediately, regardless of the state of the on-board FIFO. This mode is compatible with all other modes so that you can update selected channels at any time while others are generating an arbitrary waveform.
- **Event-Based Waveform (buffered) mode.**
This mode produces indefinite waveforms whereby the user app continuously updates data in the output buffer. The low-level driver feeds data to the board based on interrupts it receives, and it send events to the user application whenever it needs more output data. In this mode the buffer is divided into virtual segments called frames. At the end of each frame, the driver requests more data from the application (see the section on the Buffer Structure below)
- **Waveform Regenerate mode**
In this mode, the board can continuously output a waveform (with a size restricted only by the amount of physical memory on the host PC) without the intervention of user software. The waveform data is stored in PC memory and is output automatically and indefinitely by the low-level driver until the user application stops it. You can also stop waveform generation when the end of the output buffer is reached (in this case there is only one limitation: the waveform size must be less than 64M bytes).
- **Direct DSP Access mode**
This advanced variation of the Waveform Regenerate mode gives the user application direct control over the DSP buffer. It works only with small blocks of data (2k or optionally 64k samples) that fit into onboard memory.

The clock source for the last three modes can be either internal, based on a 33,000,000-Hz base, or external. Further, all waveform modes can have two variations of the channel list and maximum update speed.

We call the first one of these a *non-DMA mode*, where here the term DMA refers to on-board DSP-based DMA transfers from the DSP memory to the D/As' output buffers. Note that PCI-bus transfers are always performed in DMA mode. In this mode, the maximum update rate is approximately 500k samples per board (and 2M samples in a system with multiple boards installed). The channel list can contain any number of entries with the channels in any sequence.

Note If programming in LabVIEW, you must limit the number of entries in the channel list to 256 (any sequence is allowed).

We call the second method *DMA mode*, and it increases the output rate to 1.6M samples/sec for one board (and 3.2M samples/system), but with one tradeoff: the output channel list must have 1, 2, 4, 8, 16, 32 or 64 consecutive channels, starting from an arbitrary channel.

Programming Techniques

General procedures

The Analog Output subsystem works in the same way as all other paced subsystems. Use the following command sequence to program an AO board in a low-level language such as C, C++, Visual Basic or Delphi:

- Open the driver. This allows you to check that the driver is installed properly and started, and it also retrieves a number and the parameters of the PowerDAQ boards installed in the system.
- Open the adapter (board). After the adapter is opened, the PowerDAQ SDK returns a special handle that you should use for all calls referring to a specific installed board. This call locks that board to a specific application.
- Open the subsystem. This call grants access to one of the available AO Series board subsystems: Analog Output, Digital Input, Digital Output, DSP Counter, and Calibration. For details on this step, see the following section, "Opening a subsystem."
- Work with the subsystem. There are two ways to use a subsystem: in Synchronous and Asynchronous mode.
 - In Synchronous mode (known as Single Update on the AO subsystem) a set of calls gives direct and immediate access to the D/As, DIO ports and DSP timers, depending on the subsystem selected. You can implement timed access using OS-based timing loops.
 - In Asynchronous mode, a dedicated buffer is allocated in host memory. This buffer is divided by a number of logical blocks called frames; you generally allocate between 4 and 16 frames.

The following steps are recommended for Asynchronous mode:

- The user application makes API calls to allocate the buffer and fill it with initial data for all output subsystems
 - Assemble the subsystem configuration word using the API constants provided
 - The user application should define a set of event notifications to be received from the board; a typical set includes data-availability and error events
 - Start asynchronous operation
 - Use the *WaitForSingleObject* function call or an equivalent to check for events from the board. It is best to put this call into a separate thread. After an event, the application should re-initialize it and process the data.
 - Terminate asynchronous operation
- In Waveform Regenerate mode the user application can allocate one or more frames in the buffer, fill it with data and generate signals. The PowerDAQ driver controls event handling and supplies more data into the on-board FIFO as requested. Note

that frame size cannot exceed 64M bytes. The size of the buffer itself is limited by the amount of physical memory installed on your PC.

- Close the subsystem. When the application closes the subsystem it frees up resources.
- Close the adapter. After the adapter is closed it is accessible from other applications.
- Close the driver.

Opening a subsystem

Before starting any board operations whatsoever, you must first open the driver, open the adapter (another term that refers to a specific board), and acquire the desired subsystem. After completion of a specific task, the user application can release the subsystem, and when the application has completed its work make sure it closes the adapter and driver.

This manual explains the general procedures for creating a program and important API calls. The following calls outline the sequence you must make when programming under Win32; in particular, the calls to open/close the driver and open/close the adapter are specific to Windows. The remaining calls are valid for any OS.

For details on various functions and their calling parameters, see the *PowerDAQ Programmer Manual*, which is supplied, as a file on the PowerDAQ Software Suite CD-ROM. The specific calls and their names might vary with other operating systems, so once again you might want to refer to that manual.

API calls for opening/closing a subsystem

PdDriverOpen()

This function call opens the PowerDAQ driver for user access and returns the number of the available adapters. This step is required for the WIN32 platform only. For the QNX API use *pd_find_devices()*, and omit this function for all other OSs.

Note The *PdDriverOpen()* and *PdDriverClose()* functions do NOT have an underscore in front of them; in contrast, the functions to open/close the adapter and subsystem DO have an underscore in front of them.

_PdAdapterOpen()

This call opens a PowerDAQ card and locks it for the exclusive use of the calling user application. This function returns the *hAdapter* handle, which is used in all other adapter-related functions.

`_PdAcquireSubsystem()`

This call acquires the named subsystem for use (if you set `dwAcquire = 1`), and the parameter `dwSubsystem` can be one of the following (as defined in `typedef enum _PD_SUBSYSTEM`): AnalogOut, DigitalIn, DigitalOut or DSPCounterTimer.

... let the user app work with the subsystem, then ...

`_PdAcquireSubsystem()`

Release the subsystem from use (if you set `dwAcquire = 0`).

`_PdAdapterClose()`

Close the adapter.

`PdDriverClose()`

Close the driver.

Driver structure

The low-level PowerDAQ driver that communicates directly with an AO Series board is located in the file `pwrdaq.sys` (or `pwrdaq2K.sys` or `pwrdaq.vxd` depending on the version of Windows in use). Drivers are also available for QNX, Linux and realtime Linux patches, but this discussion covers only Windows applications. The PowerDAQ driver is responsible for communication with a board, the allocation of acquisition buffers, and event/interrupt handling. The driver works in kernel mode and is thus very efficient.

The next level of the SDK is a set of function calls, located in the `pwrdaq32.dll` dynamic link library. This library contains a complete set of low-level calls to the driver. All applications should use this library to communicate with PowerDAQ boards.

A higher level of abstraction consists of third-party drivers. They are usually implemented as DLLs and allow you to run PowerDAQ boards under well-known test-development environments including LabVIEW, DASyLab, TestPoint and Agilent VEE. For instance, our LabVIEW driver contains functions that significantly simplify the development of control applications yet maintain a feature-rich environment.

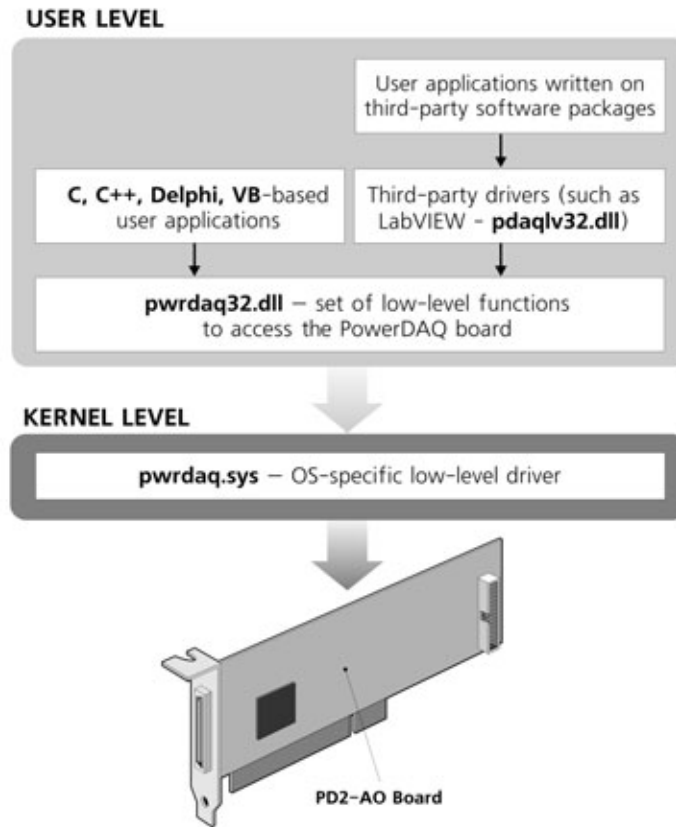
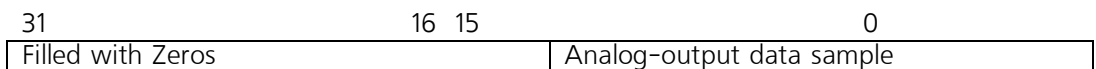

Figure 4.5—Dataflow diagram for PowerDAQ boards

Data format

The analog-output subsystem uses an unsigned 32-bit integer for data representation. We selected this format to maintain compatibility with PD2-MF(S) Series multifunction boards. The lower 16 bits contain binary data, and the upper 16 should contain Zeros.



Standard PowerDAQ AO Series boards work with a fixed $\pm 10\text{V}$ output range where

$0\text{x}0000 = -10.000\text{V}$

$0\text{x}8000 = 0.0000\text{V}$

$0\text{x}\text{FFFF} = +10.000\text{V}$

Output datapath

This section describes the data-transfer mechanism from a user application to on-board DACs.

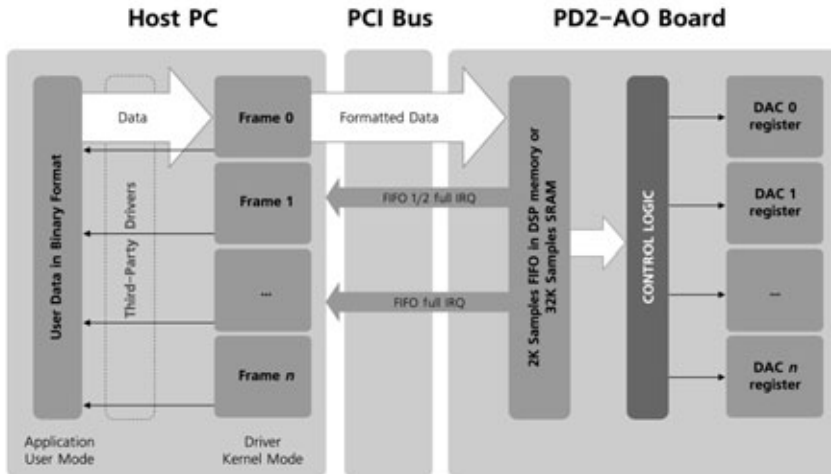

Figure 4.6—Data-transfer mechanism from user app to D/A converters on a PDx-AO board.

The user application fills a buffer, which is allocated by the driver, either directly or from its own buffer. The driver automatically adds any required additional information (such as the channel number, Write&Hold or Propagate bits) to each data sample. The driver finds this information in a channel list. After the analog-output process starts, each time the driver receives a “FIFO Half-Full” interrupt from the board, it sends the next 1k samples to the board (or 32k samples with the memory upgrade). On each analog-output clock, the DSP-based firmware takes the next data sample. If in non-DMA mode it extracts the channel number and sends this sample to the on-board logic that controls all the DACs. Data can be stored in the DACs’ output registers without immediately updating their outputs (if the Write&Hold bit is set), or the outputs can be updated immediately. If the Update All bit is set, all channels are updated with the values stored in their respective output registers. In DMA mode, the DMA process automatically generates each output channel number. This approach increases speed by factor of three but adds some limitations as noted in the following section.

Note In LabVIEW, when you specify the Update Channel number in PD AO Config.vi, all channels except the update channel will have Write&Hold bits set, and the update channel will have its Update All bit set.

Buffer structure

A user application cannot process interrupts (event notifications from a board) at a rate of thousands of times per second—only kernel-mode application such as a low-level driver can. To resolve this problem, on AO Series boards we use the Advanced Circular Buffer mechanism (see Appendix E).

In the PowerDAQ driver we define the following terms:

Frame

A frame is part of the buffer that, when its contents are completely output to the board, generates a Frame Done event to request more data. The frame size is measured in scans. You should select that size based on the desired output rate and application latency requirements. We recommend you set frame size such that the buffer issues a Frame Done event no more than 10 times/sec. For closed-loop applications you can increase this rate to 100 times/sec, but doing so will likely decrease the performance of other applications running on the same PC.

The equation for the event rate is

$$F_e = F/(S*N)$$

where

- F_e —Frame Done event rate, in Hz
- F —Analog-output update rate, in Hz
- S —Frame size, in scans
- N —Number of entries in the channel list (scan size)

Scan

One run through the output channel list (with one sample per channel)

Channel string

An array of strings, which builds up the channel list, that defines which channels the analog-output operations should update. You define the channel list in two ways. The first is to set array elements to One for those channels that should be present in the channel list. The second way is to define all channels in one string (usually first array element). Note that if only one channel is present with this definition, it should be followed by a comma.

Examples:

- "0, 1" Two channels, Ch0 and Ch1
- "0," One channel only (Ch0)
- "2, 5, 8, 15, 1, 25, 31, 17" Eight channels in the given sequence

The buffer has the structure as shown in Figure 4.7.

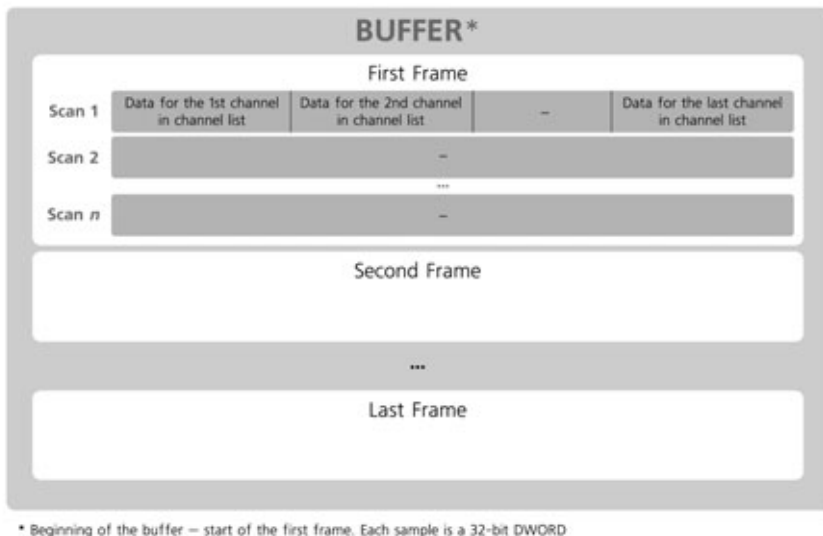

Figure 4.7—Graphical depiction of frames and scans.

Note For the Waveform Regenerate or Generate and stop modes, the LabVIEW driver allocates only one frame. This is not a limitation of the standard PowerDAQ SDK. For all other modes, the PowerDAQ LabVIEW driver defines the number of frames based on the buffer size and the frame size requested by the user; the minimum number of frames for a stable waveform output is four.

$$N_f = B / (F * N * 4)$$

where

N_f —number of frames in the buffer

B —buffer size, in bytes

N —number of channels in the channel list

4—sample size (DWORD), in bytes

When an analog-output operation starts, the low-level driver expects that the buffer is already filled with data. After it finishes outputting the first frame it notifies the user application so it can send more data.

5. Analog-Output Subsystem

As noted in the previous chapter, the analog-output subsystem on PDx-AO Series boards can function in a variety of ways and with levels of abstraction/control. This chapter gives a detailed description of how to work with the various modes and how to set up configurable parameters.

There are some minor functional differences between the PD2-AO (PCI bus) and PDXI-AO (PXI/CompactPCI) boards. For instance, one of the PCI-bus boards supplies 96 analog outputs, whereas the maximum number of D/As on the PDXI cards is 32. Next, the two families differ in what they offer in terms of sensing lines and how you configure them, an aspect addressed in detail on page 19. In addition, when PDXI boards are installed in a PXI-compatible backplane, they allow use of the PXI synchronization and triggering lines.

Data/control flow

The user application executing on the host PC transfers data to an AO board's onboard firmware using the PowerDAQ library, which ties into the board driver, which in turn communicates with the onboard firmware. The firmware then writes commands to the AO board's logic to update the D/As or perform another control action.

On the HOST: User application → PD SDK Library → PowerDAQ driver →
→ On the BOARD: Firmware → AO Logic → D/As and other peripherals

The user application, the PowerDAQ SDK and the driver work with the AO board in terms of samples and a channel list; in contrast, the firmware has no knowledge of the channel list and simply interprets raw data.

Operating modes and parameters

Output modes

As introduced in the previous chapter, the AO Series boards offer several modes for generating analog-output levels or signals:

- **Single-Point Update mode**
This mode provides an independent update of any onboard D/A. You can combine this mode with any other modes; in other words, the application can directly update any of the onboard D/As at any time regardless of any other settings.
- **Event-Based Waveform (buffered) mode**
In this mode, a D/A outputs data from a buffer allocated by the PowerDAQ driver. That driver is also responsible for transferring data from the host PC to the AO board's buffer (standard size in the DSP is 2k x 24 bits, expandable to 64k x 24 bits with an external memory upgrade). The user app should place new data in the driver's buffer based on OS events generated by the board.
- **Waveform Regenerate mode**
This mode resembles buffered mode except the driver continuously recycles through a dataset resident in the buffer without fetching any new data. If the entire dataset fits into on-board memory (2k or optionally 64k samples), the DSP automatically recycles that buffer and places no load on the host CPU.
- **Direct DSP Access mode**
This advanced variation of the Waveform Regenerate mode gives the user application direct control over the DSP buffer. It works only with small blocks of data (2k or optionally 64k samples) that fit into onboard memory.

Transfer modes

(not available in Single-Point Update mode)

- **Standard (unlimited channel-list size)**
Here data are stored in the buffer in a format where the channel number and associated actions are combined with output code. The firmware interprets this channel-number/control information on the fly, thus allowing for very flexible output-waveform control. However, this mode limits the output rate to 455k samples per board (approximately 600k samples/board for-HS models).
- **DMA**
In this mode, the channel-list size is always fixed. It can be 1, 2, 4, 8, 16, 32 or 64 consecutive channels for the Event-Based Waveform output mode; it can be any number of channels for DSP regenerate mode (when the data being recycled completely fits into the 2k/64k sample DSP memory). In either case, any available channel may serve as a start channel. Assume, for instance, that a PD2-AO-32/16 continuously updates 16 channels, and the user defines them as Ch5 to Ch20; the starting channel is then #5. This mode supports output rates to 1.6 MHz per board (2.2MHz for-HS models).

Update methods

- **Sequential**

The board updates an analog output every time the driver writes new data to the D/A

- Simultaneous
The board updates all analog outputs when the driver writes to a user-defined channel.

Update rates (speeds)

Standard AO Series boards can update waveforms on each output D/A at a rate of 100 kHz with the output settling to 16 bits, and at rates to 200 kHz with the output settling to between 11 and 12 bits.

Note There are some limitation on the maximum output rate depending on the buffered mode, the board model and the selected channel-list format selected. The following table indicates those limitations, all throughput values are given in thousands of samples/sec:

| Board model | Arbitrary channel list | Fixed channel list | Waveform Regenerate mode (using on-board memory) |
|-----------------|------------------------|--------------------|--|
| PDx-AO-8/16x | 455 | 800 | 800 |
| PDx-AO-16/16 | 455 | 1600 | 1600 |
| PDx-AO-16/16HS | 600 | 2200 | 3200 |
| PDx-AO-32/16&HC | 455 | 1600 | 1600 |
| PDx-AO-32/16HS | 600 | 2200 | 3200 |
| PD2-AO-96/16 | 455 | 1600 | 1600 |
| PD2-AO-96/16HS | 600 | 2200 | 9600 |

Table 5.1—Peak analog-output speeds on AO Series boards under various operating conditions.

Output ranges

The standard output range for D/As on most AO Series boards is $\pm 10V$. (Other output ranges are available on custom orders, and at this time we offer $\pm 2.5V$, $\pm 5V$ -10-0V and 0-10V configurations. Check our sales department for other possibilities.) The maximum current drive on standard models is 20 mA/channel for PD2-AO Series boards, except the PD2-AO-96/16, which generates 5 mA/channel. In addition, PDXI-AO boards also generate 5 mA/channel.

UEI does offer other products that allow for higher levels of both voltage and current. For details see Appendix B, Accessories. For example, to boost voltage levels, the PD-AO-AMP-100 is an external 16-channel amplifier. When used with any AO board it provides an output range of up to $\pm 100V$ and with Individual per-channel gains of 2, 10

or 20. To boost current levels, UEI offers the PD2-AO-32/16HC board. This 32-channel PCI card (not available in PXI format) generates as much as 100 mA/channel continuous.

Calibration subsystem

UEI performs calibration on all AO Series boards prior to shipping them to the customer. This calibration is performed with a NIST-traceable test fixture. The Calibration subsystem is not directly available to the user.

The Calibration subsystem on AO Series boards sets each analog output to a zero offset with 150- μ V accuracy, and it achieves the specified accuracy across the output range. (This subsystem is not needed on the PDXI-AO Series boards, which have laser-trimmed precision resistors). Calibration data is stored in an onboard EEPROM. For details on the calibration procedure, see Appendix D.

Additionally, each AO Series board comes with the *StartUpState* utility, which allows the user to configure the startup output value of any D/A. This value is loaded immediately after a system reset or power-on with a maximum latency of 200 msec.

Resets

Users can activate an onboard reset using three sources:

- Power-on reset, initialized during the power-up procedure
- PCI reset, initialized by the host. It can be either a software reset (OS initialized) or a hardware reset (from Reset button or non-maskable interrupt)
- Test/debug reset

The onboard subsystems divide an incoming reset signal into two subsignals. The first, called the DSP_RESET, actually resets the board's DSP56301 into a default state; the second, called RESET, resets the onboard DACs and the converters' control logic.

Normal reset sequence

A reset involves the following actions: Immediately following the rising edge of the DSP_RESET signal, the DSP loads the initial boot loader from the PROM and reads EEPROM data. Then it updates all D/A output values to a startup state based on user-defined values stored in EEPROM; the default factory-programmed value for each DAC is \$8000, which corresponds to 0V uncalibrated. The EEPROM is designed to retain stored values for 200 years and allows at least 1,000,000 erase/write cycles. Normally all DACs are reset synchronously with the DSP to initialize their internal state machines. They should be reset immediately during the initial power-up sequence to ensure their proper operation.

In Figure 5.1, Ch 1 represents the PCI reset signal, Ch2 is the signal from AOut0, and Ch 3 is the signal from AOut1. These channels were preset to 5V and -1V, respectively, before the reset. After the reset, the DACs change their values to 0x0000 (-10V) for

about 4.8 msec for state-machine initialization; taking on this voltage level is a normal procedure and lies within the 200-msec guaranteed setup time. This sequence and the corresponding jump to -10V occurs on any reset sequence independent of the source of the reset signal.

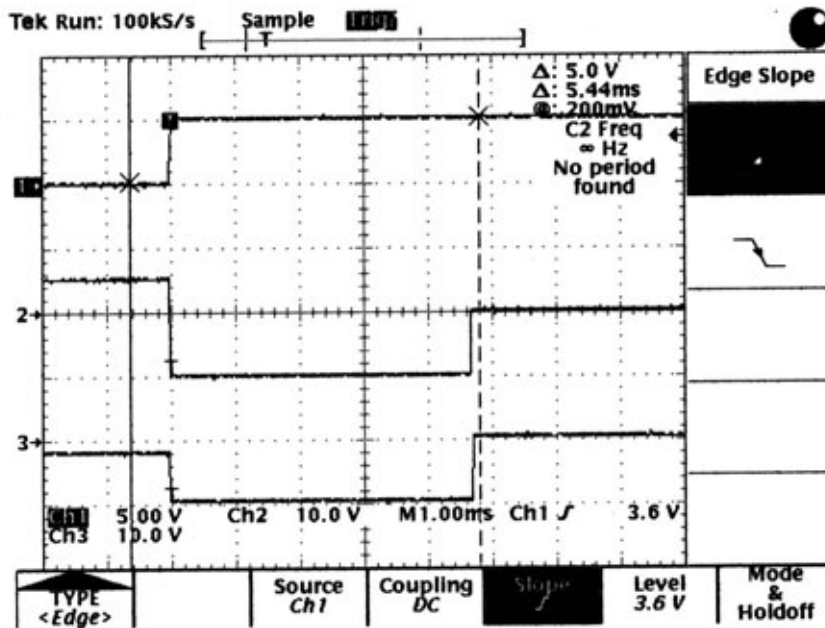

Figure 5.1—Normal reset sequence. Ch1 is the PC reset; Ch2 and Ch3 are arbitrary analog-output channels.

Clocking and triggering

An AO board needs a clock that instructs it how quickly to process entries in the channel list. You can control the clock with the following methods:

- Software strobe (`_PdAOutSwCvStart`)
- Internal clock (using the DSP timebase--33 MHz standard, 66 MHz on -HS models-- programmable with the `_PdAOAsynclnit` call)
- External clock (programmable with the `_PdAOAsynclnit` call)

The external clocking of analog outputs requires a Clock In signal, which you connect to pin TMR2.

To start an analog-output process, you must supply a trigger; triggers are also available to stop an output process. You control the trigger with the following methods:

- Software start or stop trigger (`_PdAOutSwStartTrig` or `_PdAOutSwStopTrig`)
- Software simultaneous update (`_PdAO32Update` or `_PdAO96Update`)
- External start or stop trigger (software configured using `xxTRIG` flags in `_PdAOAsynCnit`, trigger is applied to IRQC terminal)
- External simultaneous update strobe (applied to IRQB line)

Note The IRQB and IRQC interrupt lines take part in the boot process of a PDx-AO board. If you choose to use them, leave them tristated or pull them down to ground with 4.7kΩ resistors.

Both the external IRQB and IRQC triggers are negative/falling edge-sensitive. If you enable external start and stop triggers at the same time, the first negative edge of the trigger initiate an analog-output process and the second one stops it.

| Start trigger edge | Stop trigger edge | External TTL signal | Constants to use in <code>dwAOutCfg</code> configuration word |
|--------------------|-------------------|---|---|
| Falling | Falling |  | <code>AOB_STARTTRIG0+</code> <code>AOB_STARTTRIG1+</code> <code>AOB_STOPTRIG0+</code> <code>AOB_STOPTRIG1</code> |

- ◆ Acquisition started
- Acquisition stopped

Table 5.2—External trigger modes.

Simultaneous updates

A distinctive and powerful feature of AO Series boards is their simultaneous-update capability, whereby they can update all or selected analog outputs at the same time. To implement this in user code, it helps to have some basic understanding of the corresponding functionality

Limitations

All AO Series boards employ quad DACs (each holding four D/A converters). They always update data in the entire quad at the same time upon any write that requires an update of any of the quad's channels.

Channels are distributed over the quads as follows:

0-3, 4-7, 8-11, 12-15, 16-19, 20-23, 24-27, 28-31, and so on.

Note For PDXI/PD2 boards (except the AO-96/16), only AO logic dated 20020219 or later completely supports simultaneous updates.

Note For the PD2-AO-96/16, only logic dated 20020428 or later supports simultaneous updates.

Note Logic dated 20021102 or later completely complies with all the features described in this manual.

There are two possible ways to implement the simultaneous update feature:

- Incorporate control bits into the output data stream (*SW_xx* modes only, see Buffered modes description on page 51, and also see the description of the DWORD CL data format on page 65).
- Preconfigure the onboard logic using the commands described in the following section such that it updates all channels on the board upon a write to the selected channel. Only this simultaneous update mode can be combined with DMA output modes (*HW_xx*, see Buffered modes description on page 69) to achieve a simultaneous update of all channels. Use the special API function `__PdAO32[96]SetUpdateChannel` to configure the update mode of all D/As on the board. With this command you specify an Update All channel, and any subsequent write to this channel forces all the D/As to update

Further, a hardware Update All strobe input is available through the IRQB line. All channels previously written in Write&Hold mode are updated on a negative (falling) edge on this line. Note that the IRQB line must be tri-stated or held Low during a

system reset. The PD2-AO-96/16 board allows the safe use of this feature because it provides an input for a dedicated external update strobe.

Note The example programs *pdao_ou.ct* and *pdao_bu.cf*, which are installed with the SDK, both highlight how to use the simultaneous-update feature.

Programming onboard logic

AO Series boards use 16-bit quad DACs that run under control of onboard logic that you can program using the predefined command format described in Appendix C. These commands allow sequential or simultaneous updates of all onboard D/As.

Despite the differences among various AO Series boards, they share a similar command format. This format is based on the DSP memory-mapped approach where the onboard logic interprets part of the DSP address space and results in the corresponding control actions. Host programs may use direct or indirect access to the DSP memory in order to execute low-level hardware AO commands. The application implements direct access as a set of read/write functions, and you gain indirect access by programming the AO subsystem using the functions in the PowerDAQ SDK.

You can find more details about low-level programming of the PDx-AO boards in Appendix C.

Single-Point Update mode

The Single-Point Update mode gives you direct write access to any D/A converter on an AO Series board. The update rate varies with the host PC, but it is at least 1 kHz and can reach 15 kHz if the application is running under a realtime operating environment.

Note Even in Single-Point Update mode you can simultaneously update all or selected D/A outputs.

Calling sequence

Two steps are required to properly use an AO Series board (assuming that the driver, adapter and subsystem open/close operations are already in the code)

1. Disable or enable the update channel on the board (this step varies with the simultaneous/sequential update requirement). For this, use the function call `_PdAO32SetUpdateChannel(...WORD wChannel, BOOL bEnable)`

2. Write the AO data. For this, use the function call `_PdAO32WriteHold(...WORD wChannel, WORD wValue)` for all the channels you wish to update including the Update All channel, or use `_PdAO32Write()` for all channels that require an immediate update

Note For the high-density (96-channel) board you should use the following functions:
`_PdAO96SetUpdateChannel`, `_PdAO96WriteHold`, and `_PdAO96Write`.

You can find more details about low-level programming of the PDx-AO boards in Appendix C.

Note The Software Development Kit provides two examples of the Single-Point Update mode:

| | |
|---------------------------|--|
| <code>pdao_out</code> | simple non-buffered analog output (valid on all PDx-AO boards) |
| <code>AO96SimpleIO</code> | low-level simple non-buffered analog output (PD2-AO-96 only) |

Buffered updates

Rather than updating the D/As once and immediately thereafter issuing another command to update them again, two buffered update methods (Event-Based Waveform mode, and Waveform Regenerate mode) allow the continuous generation of a waveform. These modes do not limit the amount of data you can supply to the converters.

Event-Based Waveform mode

You initially fill the 2k-sample (64k samples optional, 64k standard on -HS models) DSP FIFO, and each time thereafter the FIFO drops down to half full, the DSP fires an interrupt to request that the application send an additional 1k (optional 32k) samples to the board.

The PowerDAQ ACB (Advanced Circular Buffer) mechanism hides those interrupts from the user and allows you to work with large output arrays logically divided into frames. When the subsystem reaches the end of each frame, it can generate an event that requests more data from the application. For more information about the ACB, see Appendix E.

Note If for any reason the application cannot supply enough data so the driver detects a buffer underrun error, the on-board FIFO can become empty. If the DSP has output the last value, the board continues working with the last dc value it saw.

Waveform Regenerate mode

Waveform Regenerate mode can create fixed-length waveforms without any intervention on the part of the host or user software once the application has initialized the subsystem. The app writes data to the board's buffer, and each time the DSP reaches the end of that buffer, it starts to resend the same data from the start of the buffer. Note that 2048 samples (65,536 optional) can fit into the on-board DSP memory, and autoregeneration of as many as 2048 (optionally 65,536 samples) requires no intervention by the host PC. In Waveform Regenerate mode, you can use an arbitrary number of samples.

Direct DSP Buffer Access mode

This mode is based on Waveform Regeneration mode, and here the user application can change the internal DSP counters and pointers. Firmware can output a series of samples into Waveform Regeneration mode in the range from 1 to 2048 samples (or up to 65,536 with external memory).

The following parameters are available for this mode:

StartWriteAddress (firmware parameter *AOQBuf1AddrWR*)—This provides the initial address for writing data into the DSP buffer. Internal DSP DMA operations transfer the data from PCI bus into the DSP buffer. The range of samples is from 0 to 2047 (if using the 2k internal DSP memory) or from 0 to 65,535 (if using the external on-board memory). The default value is 0. The call *_PdAOutPutBlock* writes the data into the DSP buffer starting with at *StartWriteAddress*, so before making that call *_* you should set that parameter.

StartReadAddress (firmware parameter *AOQBuf1AddrRD*)—This parameter provides the initial address for reading data from the DSP buffer. Internal DSP DMA operations transfer data beginning at this address into the output DACs. The range of samples is 0 to 2047 (if using the 2k internal DSP memory) or from 0 to 65,535 (if using external on-board memory). The default value is 0.

Offset (firmware parameter *AOQIdxMod*)—This parameter gives the current size of the DSP buffer. The range is from 0 to 2047 (if using the 2k internal DSP memory) or from 0 to 65,535 (if using external on-board memory).

Note that $(StartReadAddress+1) + (Offset+1) \leq \text{size of the DSP buffer}$. It must be controlled by the user application, otherwise we cannot guarantee that the firmware works correctly.

PdNoUpdate (same parameter in firmware)—If *PBNoUpdate* = 1 then the command *_PdAOutPutBlock* does not update *AOQIdxMod* and other internal counters (in this case you can directly update values in the DSP buffer). The default value is 0.

Note that it is necessary to set *NoUpdate* before calling *_PdAOutPutBlock* and to clear it after the function call.

These parameters are located in DSP Status Memory (*StatMem*). This memory is used to preserve status information. The address pointer of *StatMem* is located at the address `0x2` in the DSP X:memory. *StartWriteAddress* has offset 5 in *StatMem*, while *Offset* - 8, *StartReadAddress* - 33, and *NoUpdate* - 34.

For more details, see the example program *pdao_da.c* in the PowerDAQ Software Suite.

You can also use this mode to load several waveform sets (use *_PdAOutPutBlock*), and to switch among them; you change *StartReadAddress* and *Offset* (see Figure 5.3).

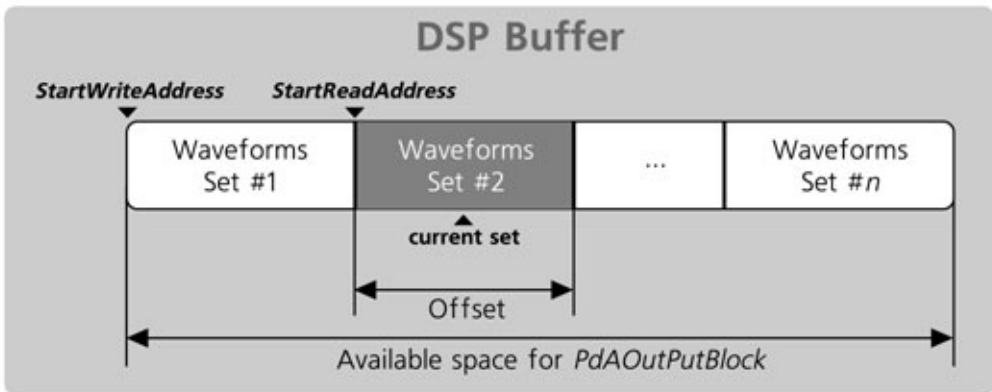

Figure 5.3—Loading and switching among multiple waveforms sets

In addition, you can update other waveform sets when the current set is output by changing *DSPDA_StartWriteAddress* and using *_PdAOutPutBlock* (see Figure 5.4).

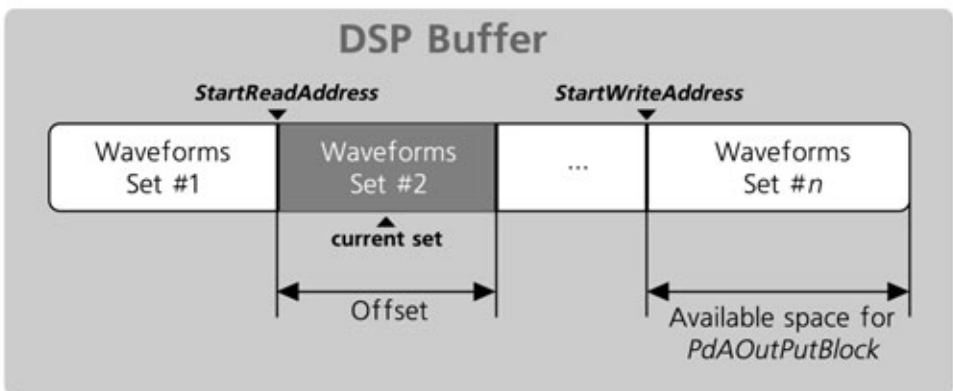

Figure 5.4—Update one waveform set while another one is being output.

Implementation:

- Open the driver: PdDriverOpen(...);
- Open an adapter: _PdAdapterOpen(...);
- Acquire a subsystem: PdAdapterAcquireSubsystem(..., AnalogOut, 1);
- Fill the data array: dwArr[i];
- Set control flags: _PdAOutSetCfg(...);
- Set the CL clock divider: _PdAOutSetCvClk(...);
- Enable interrupt from board: _PdAdapterEnableInterrupt(...);
- Put the data block directly into DSP buffer: _PdAOutPutBlock(...);
- Enable AOut conversions: _PdAOutEnableConv(...);
- Set the Software Start trigger: _PdAOutSwStartTrig(...);
- Change StartReadAddress: pdDSPStatWrite(...)|
- Change Offset: pdDSPStatWrite(...)|
- Change Offset: pdDSPStatWrite(...)|
- Change Offset: pdDSPStatWrite(...)|
- Change the StartWriteAddress: pdDSPStatWrite(...) and update the waveform set in the DSP buffer _PdAOutPutBlock(...);
- Disable the Software Start trigger _PdAOutSwStopTrig(...);
- Disable AOut conversions: _PdAOutEnableConv(...);
- Close the subsystem: PdAdapterAcquireSubsystem(..., AnalogOut, 0);
- Close the adapter: _PdAdapterClose(...);
- Close the driver: PdDriverClose(...);

Buffered update settings

To define board behavior in the buffered update methods, programmers make numerous settings in the driver or firmware. They include:

- Selecting DMA or non-DMA transfers from the DSP to the D/As. DMA transfers improve speed but decrease flexibility
- Using either the DSP's internal 2k-sample memory or the external 64k-sample option as the D/A FIFO
- Selecting Firmware Regenerate mode, Driver Regenerate mode (see details below in the section on buffer configuration), or no regenerate mode
- Whether to place output data in the driver buffer or in the host buffer either once or multiple times
- The choice of the WORD or DWORD format in the user buffer
- Whether you incorporate the channel list into the data or supply it to the driver, which then adds it to the output samples
- The choice of the Simultaneous (using hardware or software) or Sequential Update methods

Buffered update examples

Based on these settings, and because of the AO board's flexibility and the many features possible, the C-language examples in the PowerDAQ SDK define and implement a number of buffered AO modes. Each mode is described in detail in the section "Programming model for buffered modes" on page 71, including programming settings.

Note You can update any AO channel at any time by writing data directly to that channel using the Single-Point Update mode even if any of the buffered methods is selected at that time.

1. **HW_SimUpdate**—simultaneous update of all AO channels defined by the hardware (you pre-program the update channel number in on-board logic) using DMA output mode.
2. **HW_SeqUpdate**—update all channels sequentially using the DSP in DMA mode
3. **HW_SimUpdateBrdMem**—A simultaneous-update method using only on-board memory, works at rates to 9.6 MHz
4. **HW_SeqUpdateBrdMem**—A sequential-update method using only on-board memory, works with rates up to 9.6 MHz

Note Modes #3 and #4 allows data updates in the output buffer at any time.

In the following modes, "CL" in the name refers to the use of a channel list:

5. **SW_SimUpdateFixedDriverCL**—simultaneous updates using a non-DMA DSP-parsed channel list created by the driver
6. **SW_SimUpdateDriverCL**—simultaneous updates using a non-DMA DSP-parsed channel list created by the driver with Wait&Hold/Simultaneous Update bits embedded into the channel-list data
7. **SW_SimUpdateUserCL**—same as the previous method except with channel-list data is mixed with AO data and is supplied by the user
8. **SW_SeqUpdateDriverCL**—The same as Method 6 but without simultaneous updates
9. **SW_SeqUpdateUserCL**—The same as Method 7 but without simultaneous updates

Note Although some other combinations of the analog-output settings are available, the PowerDAQ SDK does not guarantee their performance or compatibility with them in any future hardware or software updates.

Note All modes may or may not include Regenerate Waveform capability, which you set by enabling one bit in the buffer configuration (see the description of Regenerate Waveform mode for details). Another feature that adds to the buffer configuration is "output buffer only one time". Those modes are not called out separately from the modes in this list, and you can easily implement them by setting appropriate buffer-configuration bits.

Buffered update configuration parameters

This section describes the configuration bits/functions you might want to use during the setup phase of a buffered operation.

Constants definitions

The following list gives the constant definitions used in the *SW_xxUserCL* modes just listed, where channel-list data is combined with D/A output values in the datastream

```
//-----
// AO 32 Subsystem Configuration (AO32) Bits
//-----
#define AO32_WRRP      0x0      // Write value to the DAC and set it
#define AO32_WRH      0x60     // Write value to the DAC but hold it
#define AO32_UPDALL    0x00     // Read to update all held DACs
#define AO32_SETUPDMD  0x40     // Read to set last channel autoupdate
#define AO32_SETUPDEN  0x20     // Must be ORed with AO32_SETUPDMD
#define AO32_BASE      0xFC0000 // Base address
#define AO32_WRITEHOLDBIT (1L<<21) // Write but not update (use in channel list)
#define AO96_WRITEHOLDBIT (1L<<23) // Write but not update (use in channel list)
#define AO32_UPDATEBIT (1L<<22) // Update all channels (use in channel list)

#define AOB_DACBASE    0xFC0000 // DAC base address
#define AOB_CTRBASE    0xBFF000 // Control registers/DIO base address
#define AOB_AO96WRITEHOLD 0x80   // Write&hold command mask
#define AOB_AO96UPDATEALL 0x100  // Update All command mask
#define AOB_AO96CFG     0x0      // Configuration register mask
#define AOB_AO96DIO     0x100    // DIO register mask

#define AO_REG0 AOB_DACBASE      // First AO register. AO_REGx = AO_REG0 + x
#define AO_WR AO32_WRRP
```

Buffer configuration

You should allocate the analog-output buffer using the *_PdAcquireBuffer()* function, which also provides flags that set several additional buffer parameters:

BUF_BUFFERWRAPPED—when this flag is cleared, the AO buffer is output only once and the driver stops the AO subsystem. This mode is useful when the user works with a predefined waveform and wants to initiate its output without putting new data into the buffer. If you clear *BUF_BUFFERWRAPPED*, you should also clear another flag, *BUF_BUFFERRECYCLED* (see below).

BUF_BUFDWORDVALUES—when this flag is set, it forces the driver to interpret data in the buffer in the format of 32-bit *DWORD* values. If this flag is cleared, the buffer assumes that all data in the buffer are in a 16-bit *WORD* format. Set this parameter if you intend to create all control bits for the AO subsystem within the user application (using the *SW_xxUserCL* modes). Setting this parameter enables a channel list with unlimited length because the channel-list data is combined with sample data; however,

it limits the AO board's maximum output speed to 455k samples/sec (600k samples/sec on -HS models).

BUF_BUFFERRECYCLED—this flag enables both firmware or driver regenerate mode. The PowerDAQ driver is intelligent enough to detect if the entire buffer fits into the on-board memory (which is either 2k or 64k samples). If so, the driver enables *Firmware Regenerate mode* whereby the board regenerates data from its internal buffer without any host involvement. If the buffer does not fit into the on-board memory the driver processes interrupts from the board and feeds new data to the board's buffer on request. This mode is called *Driver Regenerate mode*. It requires no action on the part of the programmer and uses the host PC processor, and it simplifies the user application.

Buffer data format

There are two possible data formats you can apply when preparing data for output through the D/As.

WORD data format

With the WORD format, you can consider the buffer a 1-dimensional array. Each element represents data, in straight binary format, for a single entry in the channel list. The value 0xFFFF corresponds to the maximum analog output voltage, and 0x0000 represents the minimum voltage. Thus, in the standard $\pm 10V$ range, the value 0x0000 gets output as $-10.000V$, while 0xFFFF represents $+10.000V$.

Example: Four entries in the channel list corresponding to Ch0 through Ch3; the entries use WORD-type values, where P is a pointer to the beginning of the buffer, and n is the number of samples in the buffer.

| P | P+2 | P+4 | P+6 | P+8 | P+10 | ... | P+(n-1)*2 | | | | |
|-----|-----|-----|-----|-----|------|-----|-----------|----|--|--|-----|
| CH0 | CH1 | CH2 | CH3 | CH0 | CH1 | CH2 | CH3 | .. | | | CH3 |

Note The buffer is logically divided to larger elements called frames, and frame size should be in increments of 1024 samples for all modes except Firmware Regenerate mode, when you should allocate only one frame that fits into on-board memory. Set frame size and other buffer parameters in the `_PDAOAsyncInit()` function. Also see the section "Buffer structure" on page 49.

DWORD data format

With a DWORD, data in a buffer employs a 32-bit format where:

| | | |
|--------------------|----------------------------------|------------------------|
| Bits 31-24, unused | Bits 23-16, control/channel list | Bits 15-0, output data |
|--------------------|----------------------------------|------------------------|

The Control/CL bits work as follows:

- High-density boards: PD2-AO-96/16

Bit 23—a Write&Hold bit. When set, the driver writes data to the D/A, but the output retains its previous value. When cleared, all channels are updated (AO96_WRITEHOLDBIT)

Bits 22-16—the channel number, where 0b0000000 is Ch0, 0b0000001 is Ch1, and so on until 0b1011111 is Ch95

- Standard-density boards: PDx-AO-8/16, -16/16, -32/16

Bit 22—the Update All bit (AO32_UPDATEBIT). A value of One instructs the subsystem to update all D/As with previously written data during the current clock

Bit 21—the Write&Hold bit (AO32_WRITEHOLDBIT). A value of One instructs the subsystem to write data to the D/A output register without updating it.

Bits 20-16—channel number, where 0b0000000 is Ch0, 0b0000001 is Ch1, and so on until 0b11111 is Ch31

When the driver sends data to the board, the onboard firmware interprets the control/CL bits and issues appropriate low-level AO commands. This feature adds flexibility to board's programming but limits output speed to 455k samples/sec per board.

AO subsystem configuration

You set up the AO subsystem with bit settings in the configuration word that is passed as a parameter in the `_PdAOAsyncInit()` function. Key settings include the following:

AOB_DMAEN—Enables Firmware DMA mode. In this case you should use the WORD data format and program extra control bits as part of the channel list. This mode limits channel-list size to 1, 2, 4, 8, 16, 32 or 64 channels for all modes except when the data buffer fits completely into the on-board memory. In this case it can be any number of entries from 1 to 96 channels. This mode increases the maximum output speed to 1.6M samples/sec (and even 9.6M samples/sec when only the on-board memory is used).

AOB_EXTM—Use the external-memory option for the data buffer. When this bit is set, you should select Normal Transfer mode for the AO board in the PowerDAQ Control Panel applet. In addition, that applet should report the correct size of the D/A output FIFO (64k samples)

AOB_CVSTART0 and AOB_CVSTART1—These two bits define the analog-output clock source where 00 = software clock, 11 = reserved, 01 = internal clock, and 10 = external clock

AOB_STARTTRIG0—Start Trigger source (if set, software/external falling edge)

AOB_STOPTRIG0—Stop Trigger source (if set, software/external falling edge)

AOB_REGENERATE—do not use this bit directly, the driver sets it automatically—it switches operation to Waveform Regenerate mode and uses the D/A FIFO as a circular buffer

AOB_INTCVSBASE—(if set: 11 MHz when used/33 MHz when cleared) UEI does not recommend the use of the 11-MHz base clock, which is provided only for compatibility with previous versions of the PowerDAQ SDK and may not be available in future releases.

Hardware-update channel setup

You should use the hardware-update channel setup functions at the start of the user application to set/clear the hardware-update channel before a buffered analog-output process starts.

`_PdAO32SetUpdateChannel(...WORD wChannel, BOOL bEnable)`

Note For the high-density 96-channel board, use the `PdAO96SetUpdateChannel` functions.

Channel-list configuration

You configure the channel list in the `_PdAOAsynInit()` call, which requires different information depending on the mode selected. There are two parameters: channel-list size (`dwChListSize`), and the channel-list data itself (an array of 32-bit DWORDS).

Channel-list size

This value should be 0 if you integrate the channel list into the data (in this case, the buffer should be in the DWORD format), or for all other modes this value should be the actual number of channels in the list. The maximum size of the channel list is 256 entries. Note that in DMA mode (where `AOB_DMAEN` is set) the channel-list must be 1, 2, 4, 8, 16, 32 or 64 entries for all modes except `HW_SimUpdateBrdMem` and `HW_SeqUpdateBrdMem`.

Channel-list data

Each entry in the channel list contains two values: the channel number to be updated, and control bits necessary for some modes. Note that for the DMA modes, the driver uses only the first entry in the channel list, which contains the number of the first channel and an optional Write&Hold bit.

- DMA mode channel-list data format (only the first entry in the list is used)

High-density (96-channel board) format

| | |
|------------|-------------------------------|
| Bit 7—Hold | Bits 6-0—first channel number |
|------------|-------------------------------|

Set the Write&Hold bit (*AOB_AO96WRITEHOLD*) to 1 when using simultaneous updates. The first channel number (bits 6-0) defines the start channel in the channel list. For example, if outputting 16 channels starting from channel 36 using simultaneous updates, the first and only entry in the channel list is 0xA4 (10100100 binary).

Standard-density format

| | | |
|---------|---------------|-------------------------------|
| Bit 7-0 | Bits 6-5—Hold | Bits 4-0—first channel number |
|---------|---------------|-------------------------------|

For most AO cards, you set bits 6-5 (the Update All/Write&Hold bits) (*AO32_WRH*) to 01 binary when using simultaneous updates. The first channel number represents the starting channel in the channel list. For example: if outputting 9 channels starting from channel 6 using simultaneous updates, the first and only entry in the channel list is 0x29 (00101001 binary).

- Non-DMA mode channel-list data format (all entries in the list are used)

High-density (96-channel) format

| | |
|------------|-------------------------|
| Bit 7—Hold | Bits 6-0—channel number |
|------------|-------------------------|

You must set the Hold bit (*AOB_AO96WRITEHOLD*) to 1 when using the Firmware Simultaneous Update mode for all channels except the update channel, which you selected in *_PdAO96SetUpdateChannel()*.

Standard-density format

| | | |
|---------|----------------------|-------------------------|
| Bit 7-0 | Bits 6-5—Hold/Update | Bits 4-0—channel number |
|---------|----------------------|-------------------------|

Bits #6 (AO32_SETUPDMD) and #5 (AO32_SETUPDEN) select the update mode for the channel specified in bits 4-0. When firmware simultaneous update mode is in use, you should set bit #5 (AO32_SETUPDEN) for all channels in the channel list, and set bit #6 (AO32_SETUPDMD) only to the last channel in the channel list.

Software update channel setup

You set up the software-update channel by configuring the buffer in the DWORD format and setting all control bits as described above, or by adding the Write&Hold and Update All bits into the channel list.

The following table summarizes the parameters for the various buffered modes. The PowerDAQ SDK includes a sophisticated example, *pdao_buf.c*, that supports all of these modes and serves as a good starting point for implementing any buffered analog-output applications. In addition, the program *PDAOSineWave.c* shows a buffered example in C++ that highlight techniques you can use to apply different output frequencies on different AO channels

Note In the column for Regenerate feature, if the buffer fits into the onboard memory (2k samples standard, 64k samples optional), no host involvement is required for continuous data output.

| | Mode | Max output rate (kHz) [-HS] | Channel-list size (entries) | Maximum waveform size (samples) | User data format | Regenerate feature | Simultaneous update |
|---|----------------------------|------------------------------------|---|--|-------------------------|---|--|
| 1 | HW_SimUpdate | 1600 [2200] | 1, 2, 4, 8, 16, 32, 64 | Unlimited, data is sent on request | WORD (16 bit) | By the driver with host / PCI involvement (see note) | Yes, by the hardware, 1-time programmed, only one channel used as an update channel |
| 2 | HW_SeqUpdate | 1600 [2200] | 1, 2, 4, 8, 16, 32, 64 | Unlimited, data is sent on request | WORD (16 bit) | By the driver with host / PCI involvement (see note) | No |
| 3 | HW_SimUpdate BrdMem | 9600 | 1-96 | 2k or 64k | WORD (16 bit) | Yes, by the board without host usage | Yes, by the hardware, 1-time programmed, only one channel used as an update channel |
| 4 | HW_SeqUpdate BrdMem | 9600 | 1-96 | 2k or 64k | WORD (16 bit) | Yes, by the board without host usage | No |
| 5 | SW_SimUpdate FixedDriverCL | 455 [600] | 1-256, user supplies channel list to the driver | Unlimited, data is sent on request | WORD (16 bit) | By the driver with host / PCI involvement. (see note) | Yes, by the hardware, 1-time programmed, only one channel used as an update channel |
| 6 | SW_SimUpdate DriverCL | 455 [600] | 1-256, user supplies channel list to the driver | Unlimited, data is sent on request | WORD (16 bit) | By the driver with host / PCI involvement (see note) | Yes, by the firmware, driver adds up control bits, any number of update channels supported |

| | | | | | | | |
|---|--------------------------|--------------|---|---|---------------------------------------|--|---|
| 7 | SW_SimUpdate UserCL | 455 [600] | Unlimited (mixed with data) | Unlimited, data is sent on request | DWORD (32 bit, 24 LSBs used) | By the driver with host / PCI involvement (see note) | Yes, by the firmware, user adds up control bits, any number of update channels supported |
| 8 | SW_SeqUpdate DriverCL | 455 [600] | 1-256, user supply CL to the driver | Unlimited, data is sent on request | WORD (16 bit) | By the driver with host/PCI involvement (see note) | No |
| 9 | SW_SeqUpdate UserCL | 450 | Unlimited (mixed with data) | Unlimited, data is sent on request | DWORD (32 bit, 24 LSBs used) | By the driver with host/PCI involvement (see note) | No |

Table 5.2—Parametric table for buffered modes

Modes 1 through 4 in Table 5.2 use DMA on the onboard DSP to transfer data from the buffer to the D/A. This gives advantages in speed with a tradeoff in flexibility in terms of the channel-list size and structure: in Mode 1 (HW_SimUpdate) and Mode 2 the channel-list size is only a power of two, and for Mode 3 (HW_SimUpdateBrdMem) and Mode 4 (HW_SeqUpdateBrdMem) the channel-list size must fall between 1 and 96 channels.

Programming model for buffered modes

The following section examines each of the buffered modes listed in Table 5.2 and provides a brief outline of how to set up and execute an analog-output operation.

Mode 1—HW_SimUpdate

DMA, hardware simultaneous update at 1.6 MHz (2.2 MHz on -HS models)

- Open driver: *PdDriverOpen(...)*
- Open adapter: *_PdAdapterOpen(...)*
- Acquire subsystem: *PdAdapterAcquireSubsystem(..., AnalogOut, 1)*
- Set events notify: *dwEventsNotify = eFrameDone|eBufferDone|eBufferError|eStopped...*
- Set buffer mode flag: *BUF_BUFFERWRAPPED* (cycle buffer)
- Acquire buffer: *_PdAcquireBuffer(...)*
- Put data into the buffer

- Set analog-output subsystem configuration: *dwAoCfg* |= *AOB_DMAEN* (DMA enable) | *AOB_CVSTART0* (AO internal clock) | *AOB_INTCVSBASE* (base clock 33 MHz)
- Set Write&Hold flag:
 AOChList[0] = *AOB_AO96WRITEHOLD* for AO96 board;
 AOChList[0] = *AO32_WRH* for AO32 board
- Initialize AO Async operation: *_PdAOAsyncInit(..., dwAoCfg, dwAoCvClkDiv, dwEventsNotify, dwAOChListSize, AOChList)*
- Sets channel number that triggers update line upon a write to it (hardware update):
 _PdAO96SetUpdateChannel(..., dwAOChListSize-1, TRUE) for AO96 board;
 _PdAO32SetUpdateChannel(..., dwAOChListSize-1, TRUE) for AO32 board;
- Set private event: *_PdAOSetPrivateEvent(...)*
- Starts buffered operation: *_PdAOAsyncStart(...)*
- Wait for events: *WaitForSingleObject(...)*
 _PdGetUserEvents(...)
 _PdAOGetBufState(...)
 Put new scans
 Reset user events: *_PdSetUserEvents(...)*
- Stop buffered analog-output operation: *_PdAOAsyncStop(...)*
- Clear private event: *_PdAOClearPrivateEvent(...)*
- Terminate analog-output operation: *_PdAOAsyncTerm(...)*
- Release buffer: *_PdReleaseBuffer(...)*
- Close subsystem: *PdAdapterAcquireSubsystem(..., AnalogOut, 0)*
- Close adapter: *_PdAdapterClose(...)*
- Close driver: *PdDriverClose(...)*

Mode 2—HW_SeqUpdate

DMA, 1.6-MHz (2.2 MHz on -HS boards) hardware sequential update; every channel updated at the time data is written to that channel

- Open driver: *PdDriverOpen(...)*
- Open adapter: *_PdAdapterOpen(...)*
- Acquire subsystem: *PdAdapterAcquireSubsystem(..., AnalogOut, 1)*
- Set events notify: *dwEventsNotify* =
 eFrameDone|eBufferDone|eBufferError|eStopped...
- Set buffer mode flag: *BUF_BUFFERWRAPPED* (cycle buffer)
- Acquire buffer: *_PdAcquireBuffer(...)*
- Put data into the buffer
- Set analog-output subsystem configuration: *dwAoCfg* |= *AOB_DMAEN* (DMA enable) | *AOB_CVSTART0* (AO internal clock) | *AOB_INTCVSBASE* (base clock 33 MHz)
- Initialize AO Async operation: *_PdAOAsyncInit(..., dwAoCfg, dwAoCvClkDiv, dwEventsNotify, dwAOChListSize, AOChList)*

- Disable hardware update:
 - `_PdAO96SetUpdateChannel(..., dwAOChListSize-1, FALSE)` for AO96 board
 - `_PdAO32SetUpdateChannel(..., dwAOChListSize-1, FALSE)` for AO32 board
- Set private event: `_PdAOSetPrivateEvent(...)`
- Starts buffered operation: `_PdAOAsyncStart(...)`
- Wait for events: `WaitForSingleObject(...)`
 - `_PdGetUserEvents(...)`
 - `_PdAOGetBufState(...)`
 Put new scans
 Reset user events: `_PdSetUserEvents(...)`
- Stop buffered analog-output operation: `_PdAOAsyncStop(...)`
- Clear private event: `_PdAOClearPrivateEvent(...)`
- Terminate analog-output operation: `_PdAOAsyncTerm(...)`
- Release buffer: `_PdReleaseBuffer(...)`
- Close subsystem: `PdAdapterAcquireSubsystem(..., AnalogOut, 0)`
- Close adapter: `_PdAdapterClose(...)`
- Close driver: `PdDriverClose(...)`

Mode 3—HW_SimUpdateBrdMem

DMA, hardware simultaneous update 3.2 MHz (9.6 MHz on -HS boards), onboard memory only

Note A limitation of this mode is that the maximum number of samples in the buffer must fit into onboard memory which means 2k samples (64k samples with memory option).

- Open driver: `PdDriverOpen(...)`
- Open adapter: `_PdAdapterOpen(...)`
- Acquire subsystem: `PdAdapterAcquireSubsystem(hAdapter, &dwError, AnalogOut, 1)`
- Set buffer mode flags: `BUF_BUFFERWRAPPED` (cycle buffer)|
`BUF_BUFFERRECYCLED` (buffer recycled)
- Acquire buffer: `_PdAcquireBuffer(...)`

Note The size of the PowerDaq buffer should be \leq to the size of the onboard memory (2k or 64k samples). We recommend that you set the number of frames = 1 (`AO_BUFFER_FRAMES`) to correctly calculate the buffer size.

- Put data into the buffer
- Set the analog-output subsystem configuration: `dwAoCfg |= AOB_DMAEN` (DMA enable)| `AOB_CVSTART0` (AO internal clock) | `AOB_INTCVSBASE` (base clock 33 MHz)
- Set Write&Hold flag:
 - `AOChList[0] = AOB_AO96WRITEHOLD` for AO96 board
 - `AOChList[0] = AO32_WRH` for AO32 board

- Initialize AO Async operation: *PdAOAsyncInit(..., dwAoCfg, dwAoCvClkDiv, 0, dwAOChListSize, AOChList)*
- Set channel number that triggers update line upon write to it (hardware update):
 _PdAO96SetUpdateChannel(..., dwAOChListSize-1, TRUE) for AO96 board
 _PdAO32SetUpdateChannel(..., dwAOChListSize-1, TRUE) for AO32 board
- Set private event: *_PdAOSetPrivateEvent(...)*
- Starts buffered operation: *_PdAOAsyncStart(...)*
- Wait for events: *WaitForSingleObject(...)*
 _PdGetUserEvents(...)
 _PdAOGetBufState(...)
 Put new scans
 Reset user events: *_PdSetUserEvents(...)*
- Stop buffered analog-output buffered: *_PdAOAsyncStop(...)*
- Clear private event: *_PdAOClearPrivateEvent(...)*
- Terminate analog output operation: *_PdAOAsyncTerm(...)*
- Release buffer: *_PdReleaseBuffer(...)*
- Close subsystem: *PdAdapterAcquireSubsystem(..., &dwError, AnalogOut, 0)*
- Close adapter: *_PdAdapterClose(...)*
- Close driver: *PdDriverClose(...)*

Mode 4—HW_SeqUpdateBrdMem

DMA , 3.2 MHz (9.6 MHz on -HS boards), onboard memory only

- Open driver: *PdDriverOpen(...)*
- Open adapter: *_PdAdapterOpen(...)*
- Acquire subsystem: *PdAdapterAcquireSubsystem(..., AnalogOut, 1)*
- Set buffer mode flags: *BUF_BUFFERWRAPPED* (cycle buffer)
 BUF_BUFFERRECYCLED (buffer recycled)
- Acquire buffer: *_PdAcquireBuffer(...)*.

Note The size of the PowerDaq buffer should be <= to the size of the onboard memory (2k or 64k samples). We recommend that you set the number of frames = 1 (*AO_BUFFER_FRAMES*) to correctly calculate the buffer size.

- Put data into the buffer
- Set Analog output subsystem configuration: *dwAoCfg |= AOB_DMAEN* (DMA enable) | *AOB_CVSTART0* (AO internal clock) | *AOB_INTCVSBASE* (base clock 33 MHz)
- Initialize AO Async operation: *_PdAOAsyncInit(hAdapter, &dwError, dwAoCfg, dwAoCvClkDiv, 0, dwAOChListSize, AOChList)*
- Disable hardware update:
 _PdAO96SetUpdateChannel(..., dwAOChListSize-1, FALSE) for AO96 board
 _PdAO32SetUpdateChannel(..., dwAOChListSize-1, FALSE) for AO32 board

- Set private event: `_PdAOSetPrivateEvent(...)`
- Starts buffered operation: `_PdAOAsyncStart(...)`
- Wait for events: `WaitForSingleObject(...)`
 - `_PdGetUserEvents(...)`
 - `_PdAOGetBufState(...)`
 - Put new scans
 - Reset user events: `_PdSetUserEvents(...)`
- Stop buffered analog-output operation: `_PdAOAsyncStop(...)`
- Clear private event: `_PdAOClearPrivateEvent(...)`
- Terminate analog output operation: `_PdAOAsyncTerm(...)`
- Release buffer: `_PdReleaseBuffer(...)`
- Close subsystem: `PdAdapterAcquireSubsystem(..., AnalogOut, 0)`
- Close adapter: `_PdAdapterClose(...)`
- Close driver: `PdDriverClose(...)`

Mode 5—SW_SimUpdateFixedDriverCL

Hardware simultaneous update, 455 kHz (600 kHz on -HS boards), driver-created channel list

- Open driver: `PdDriverOpen(...)`
- Open adapter: `_PdAdapterOpen(...)`
- Acquire subsystem: `PdAdapterAcquireSubsystem(..., AnalogOut, 1)`
- Set events notify: `dwEventsNotify = eFrameDone|eBufferDone|eBufferError|eStopped...`
- Set buffer mode flag: `BUF_BUFFERWRAPPED` (cycle buffer)
- Acquire buffer: `_PdAcquireBuffer(...)`
- Put data into the buffer
- Generate channel list and set flag:
 - `AOB_AO96WRITEHOLD` for AO96 board:
`AOChList[i] = (i & 0xf)|AOB_AO96WRITEHOLD)`
 - `AO32_SETUPDEN` for AO32 board:
`AOChList[i] = (i & 0xf)|AO32_SETUPDEN)`
- Set analog-output subsystem configuration: `dwAoCfg |= AOB_CVSTART0` (AO internal clock) | `AOB_INTCVSBASE` (base clock (33 MHz))
- Initialize AO Async operation: `_PdAOAsyncInit(..., dwAoCfg, dwAoCvClkDiv, dwEventsNotify, dwAOChListSize, AOChList)`
- Set channel number that triggers update line upon write to it (hardware update):
 - `_PdAO96SetUpdateChannel(..., dwAOChListSize-1, TRUE)` for AO96 board
 - `_PdAO32SetUpdateChannel(..., dwAOChListSize-1, TRUE)` for AO32 board;
- Set private event: `_PdAOSetPrivateEvent(...)`
- Start buffered operation: `_PdAOAsyncStart(...)`

- Wait for events: *WaitForSingleObject(...)*
 _PdGetUserEvents(...)
 _PdAOGetBufState(...)
 Put new scans
 Reset user events: *_PdSetUserEvents(...)*
- Stop buffered analog-output operation: *_PdAOAsyncStop(...)*
- Clear private event: *_PdAOClearPrivateEvent(...)*
- Terminate analog output operation: *_PdAOAsyncTerm(...)*
- Release buffer: *_PdReleaseBuffer(...)*
- Close subsystem: *PdAdapterAcquireSubsystem(..., AnalogOut, 0)*
- Close adapter: *_PdAdapterClose(...)*
- Close driver: *PdDriverClose(...)*

Mode 6—SW_SimUpdateDriverCL

Software simultaneous update, 455 kHz (600 kHz on -HS boards), driver-created channel list

- Open driver: *PdDriverOpen(...)*
- Open adapter: *_PdAdapterOpen(...)*
- Acquire subsystem: *PdAdapterAcquireSubsystem(..., AnalogOut, 1)*
- Set events notify: *dwEventsNotify = eFrameDone|eBufferDone|eBufferError|eStopped...*
- Set buffer mode flag: *BUF_BUFFERWRAPPED* (cycle buffer)
- Acquire buffer: *_PdAcquireBuffer(...)*
- Put data into the buffer
- Generate channel list and set autoupdate flag:
 AOB_AO96WRITEHOLD for AO-96/16 board:
 (i=dwAOChListSize-1)?(AOChList[i]=i & 0xf):(AOChList[i]=(i & 0xf)|AOB_AO96WRITEHOLD)
 AO32_SETUPDMD for AO-32/16 board:
 (i=dwAOChListSize-1)?(AOChList[i]=(i & 0xf)|AO32_SETUPDMD|AO32_SETUPDEN):(AOChList[i]=(i & 0xf)|AO32_SETUPDEN)
- Set analog-output subsystem configuration: *dwAoCfg |= AOB_CVSTART0* (AO internal clock) | *AOB_INTCVSBASE* (base clock 33Mhz)
- Initialize AO Async operation:
 _PdAOAsyncInit(..., dwAoCfg, dwAoCvClkDiv, dwEventsNotify, dwAOChListSize, AOChList)
- Disable hardware update:
 _PdAO96SetUpdateChannel(..., dwAOChListSize-1, FALSE) for AO96 board
 _PdAO32SetUpdateChannel(..., dwAOChListSize-1, FALSE) for AO32 board
- Set private event: *_PdAOSetPrivateEvent(...)*

- Starts buffered process: `_PdAOAsyncStart(...)`
- Wait for events: `WaitForSingleObject(...)`
`_PdGetUserEvents(...)`
`_PdAOGetBufState(...)`
Put new scans
Reset user events: `_PdSetUserEvents(...)`
- Stop buffered analog-output operation: `_PdAOAsyncStop(...)`
- Clear private event: `_PdAOClearPrivateEvent(...)`
- Terminate analog output operation: `_PdAOAsyncTerm(...)`
- Release buffer: `_PdReleaseBuffer(...)`
- Close subsystem: `PdAdapterAcquireSubsystem(..., AnalogOut, 0)`
- Close adapter: `_PdAdapterClose(...)`
- Close driver: `PdDriverClose(...)`

Mode 7—SW_SimUpdateUserCL

Software simultaneous update, 455 kHz (600 kHz on -HS boards), user-created channel list

- Open driver: `PdDriverOpen(...)`
- Open adapter: `_PdAdapterOpen(...)`
- Acquire subsystem: `PdAdapterAcquireSubsystem(..., AnalogOut, 1)`
- Set events notify: `dwEventsNotify = eFrameDone|eBufferDone|eBufferError|eStopped...`
- Set buffer mode flags: `BUF_BUFFERWRAPPED` (cycle buffer) | `BUF_DWORDVALUES` (use DWORD values)
- Acquire buffer: `_PdAcquireBuffer(...)`
- Put data into the buffer and incorporate info for channel list, update bits into data (for AO-96/16 board use flag `AO96_WRITEHOLDBIT`, for AO-32/16 board use flags `AO32_WRITEHOLDBIT` and `AO32_UPDATEBIT`)
- Set analog-output subsystem configuration: `dwAoCfg |= AOB_CVSTART0` (AO internal clock) | `AOB_INTCVSBASE` (base clock 33 MHz)
- Initialize AO Async operation: `_PdAOAsyncInit(..., dwAoCfg, dwAoCvClkDiv, dwEventsNotify, 0, AOChList)`
- Disable hardware update:
`_PdAO96SetUpdateChannel(..., dwAOChListSize-1, FALSE)` for AO96 board
`_PdAO32SetUpdateChannel(..., dwAOChListSize-1, FALSE)` for AO32 board
- Set private event: `_PdAOSetPrivateEvent(...)`
- Starts buffered process: `_PdAOAsyncStart(...)`
- Wait for events: `WaitForSingleObject(...)`
`_PdGetUserEvents(...)`
`_PdAOGetBufState(...)`
Put new scans
Reset user events: `_PdSetUserEvents(...)`
- Stop buffered analog-output operation: `_PdAOAsyncStop(...)`

- Clear private event: `_PdAOClearPrivateEvent(...)`
- Terminate analog-output operation: `_PdAOAsyncTerm(...)`
- Release buffer: `_PdReleaseBuffer(...)`
- Close subsystem: `PdAdapterAcquireSubsystem(..., AnalogOut, 0)`
- Close adapter: `_PdAdapterClose(...)`
- Close driver: `PdDriverClose(...)`

Mode 8—SW_SeqUpdateDriverCL

455 kHz (600 kHz on -HS models), driver-generated channel list

- Open driver: `PdDriverOpen(...)`
- Open adapter: `_PdAdapterOpen(...)`
- Acquire subsystem: `PdAdapterAcquireSubsystem(..., AnalogOut, 1)`
- Set events notify: `dwEventsNotify = eFrameDone|eBufferDone|eBufferError|eStopped...`
- Set buffer mode flag: `BUF_BUFFERWRAPPED` (cycle buffer)
- Acquire buffer: `_PdAcquireBuffer(...)`
- Put data into the buffer
- Generate the channel list
- Set analog-output subsystem configuration: `dwAoCfg |= AOB_CVSTART0` (AO internal clock) | `AOB_INTCVSBASE` (base clock 33 MHz)
- Initialize AO Async operation:
`_PdAOAsyncInit(..., dwAoCfg, dwAoCvClkDiv, dwEventsNotify, dwAOChListSize, AOChList)`
- Disable hardware update:
`_PdAO96SetUpdateChannel(..., dwAOChListSize-1, FALSE)` for AO96 board
`_PdAO32SetUpdateChannel(..., dwAOChListSize-1, FALSE)` for AO32 board
- Set private event: `_PdAOSetPrivateEvent(...)`
- Starts buffered operation: `_PdAOAsyncStart(...)`
- Wait for events: `WaitForSingleObject(...)`
`_PdGetUserEvents(...)`
`_PdAOGetBufState(...)`
Put new scans
Reset user events: `_PdSetUserEvents(...)`
- Stop buffered analog-output operation: `_PdAOAsyncStop(...)`
- Clear private event: `_PdAOClearPrivateEvent(...)`
- Terminate analog-output operation: `_PdAOAsyncTerm(...)`
- Release buffer: `_PdReleaseBuffer(...)`
- Close subsystem: `PdAdapterAcquireSubsystem(..., AnalogOut, 0)`
- Close adapter: `_PdAdapterClose(...)`
- Close driver: `PdDriverClose(...)`

Mode 9—SW_SeqUpdateUserCL

455 KHz (600 kHz on HS models), user-created channel list

- Open driver: *PdDriverOpen(...)*
- Open adapter: *_PdAdapterOpen(...)*
- Acquire subsystem: *PdAdapterAcquireSubsystem(..., AnalogOut, 1)*
- Set events notify: *dwEventsNotify = eFrameDone|eBufferDone|eBufferError|eStopped...*
- Set buffer mode flag: *BUF_BUFFERWRAPPED* (cycle buffer)| *BUF_DWORDVALUES* (use DWORD values)
- Acquire buffer: *_PdAcquireBuffer(...)*
- Put data into the buffer and incorporate channel list into the data
- Set analog-output subsystem configuration: *dwAoCfg |= AOB_CVSTART0* (AO internal clock)| *AOB_INTCVSBASE* (base clock 33 MHz)
- Initialize AO Async operation: *_PdAOAsyncInit(..., dwAoCfg, dwAoCvClkDiv, dwEventsNotify, 0, AOChList)*
- Disable hardware update:
 - _PdAO96SetUpdateChannel(..., dwAOChListSize-1, FALSE)* for AO96 board
 - _PdAO32SetUpdateChannel(..., dwAOChListSize-1, FALSE)* for AO32 board
- Set private event: *_PdAOSetPrivateEvent(...)*
- Starts buffered operation: *_PdAOAsyncStart(...)*
- Wait for events: *WaitForSingleObject(...)*
 - _PdGetUserEvents(...)*
 - _PdAOGetBufState(...)*
 - Put new scans
 - Reset user events: *_PdSetUserEvents(...)*
- Stop buffered analog-output operation: *_PdAOAsyncStop(...)*
- Clear private event: *_PdAOClearPrivateEvent(...)*
- Terminate analog output operation: *_PdAOAsyncTerm(...)*
- Release buffer: *_PdReleaseBuffer(...)*
- Close subsystem: *PdAdapterAcquireSubsystem(..., AnalogOut, 0)*
- Close adapter: *_PdAdapterClose(...)*
- Close driver: *PdDriverClose(...)*

6. Digital I/O Subsystem

Architecture

The digital I/O subsystem on all AO Series boards contains one 8-bit input register and one 8-bit output register. The digital I/O registers do not support clocked operation, so you can use this subsystem only in software-pollled mode.

On all dedicated digital input lines the board comes with 4.7-k Ω pullup resistors. In fact, we supply these resistors on all digital inputs including all external trigger lines, all external clock inputs, and counter/timer inputs.)

Programming Techniques

The digital input/output subsystem can be used in two ways, and recall that this subsystem has no clocked operations available.

- Polled I/O
- Change-of-state interrupts on digital input

Polled I/O

This method works by using software to poll 8 digital inputs and 8 digital outputs.

Note Examples in the SDK for the Digital I/O subsystem are:

- Pdmf_din.c simple example – uses digital inputs only
- Pdmf_dou.c simple polled I/O example, DOut only
- SimpleTest.dpr accesses DIO on the AO boards as a part of more complex example program

The following discussion examines the stages of programming the digital I/O subsystem

Initialization

Reset the digital subsystem

 _*PdDOutReset(...)* sets the output lines to Zero

 _*PdDInReset(...)* clears the latch and the configuration register

Input/output

Read digital inputs

 _*PdDInRead(...)*

Write digital outputs

 _*PdDOutWrite(...)*

Change-of-state interrupts on digital input

In this scheme you set up an input configuration, and the subsystem fires an event when it detects any change on the specified digital input channels. Once the subsystem detects a change, the board returns a list of the changed bits and direction of the change (0->1 or 1->0).

The setup parameters for this method are very similar to those in polled I/O method. The difference is that you should additionally enable and set up event notification. Digital inputs can share an event handler with other subsystems or can have a dedicated event handler.

Note Examples in the SDK that fall into this category are:

- `DIEvents.c`

Initialization

Reset the digital-input subsystem with

 _*PdDInReset(...)*

to clear the latch and configuration register

Set up the digital-input configuration

Set up the edge-sensitivity configuration

 _*PdDInSetCfg(...)*

Specify an input line and an edge to be detected using a configuration word

 _*PdAdapterEnableInterrupt(...)* with *dwEnable* set to 1

 _*PdDInSetPrivateEvent(...)* sets up event object

 _*PdSetUserEvent(...)*

and use *DigitalIn* as a subsystem name. The driver defines only one digital-input event, *eDInEvent*, which means that one or more edges were detected

Event handler

Check for events:

`_PdGetUserEvent(...)`

should return the *eDInEvent* flag in the status word.

Read the status of the digital-input latch

`_PdDInGetStatus(...)`

This function returns the current state of the digital-input lines in one byte and the status of the digital-input latch register in a second byte. If the specified edge was detected, the latch contains a One in the appropriate bit.

Clear the status of the digital input latch with

`_PdDInClearData(...)`

It clears the latch register and re-enables edge detection on the line that previously caused an event

Re-enable events with

`_PdSetUserEvent(...)`

and use *Digitalln* as a subsystem name. The driver defines only one digital-input event, *eDInEvent*, which means that one or more edges were detected

De-Initialization

Disable interrupts if there is no other subsystem running

`_PdAdapterEnableInterrupt(...)` with *dwEnable* set to 0

Release the event object and clear user-level events

`_PdDInClearPrivateEvent(...)`

`_PdClearUserEvent(...)` and use *Digitalln* as the subsystem name

Reset the digital inputs to clear the configuration and latch registers

`_PdDInReset(...)`

7. Counter/Timer Subsystem

Architecture

The counter/timer subsystem on each AO Series card features three 24-bit counters (TMR0, TMR1 and TMR2) integrated into the onboard Motorola 56301 DSP. All three are available to users (although PDx-AO boards use TMR2 to define a timebase for streamed outputs), and they all share an optional 21-bit divider called a prescaler. Each counter has its own load, count, status and compare registers. Please refer to the example source code supplied in the PowerDAQ SDK and the *Motorola DSP56301 DSP User Manual* (Motorola PN DSP565301UM, available on www.mot.com) for extensive details about programming the DSP's counter/timers.

Each timer can use internal or external clocking. Each can interrupt the DSP after a specified number of events (clock pulses), or it can signal an external device after counting internal events. Each timer connects to the external world through a single bidirectional pin (TIOx) that is protected to 7 kV against electrostatic discharge and $\pm 30V$ against overvoltage. When you configure TIOx as an input, the timer functions as an external event counter, or it can measure an external pulse's width or signal period. When you configure TIOx as an output, the timer functions as either a timer, a watchdog or a pulse-width modulator.

Note If, for any reason, the protection device detects an overvoltage condition, it clamps the input signal to the positive or negative supply rail. It can take as long as 200 msec for the protection device to exit this saturation/clamping state once the input voltage returns to the allowable range

Some common timer/counter/output functions that applications often require are:

- Realtime clock
- Event counter
- Digital one-shot
- Programmable rate generator
- Squarewave generator
- Binary-rate multiplier
- Complex digital waveform generator

- Complex motor controller

Each counter functions as a 24-bit up counter. On power-up, the DSP sets the count value and output of every counter to zero. You must program each counter with commands from the API before using it; unused counters need not be programmed. Each counter is fully independent of the others except all share the same prescaler; each may operate in a different mode.

Programming the counter/timers

Generally, you set up counter/timer functions using the following steps:

1. Acquire all resources

Open the driver: `PdDriverOpen()`

Open the adapter: `_PdAdapterOpen()`

Acquire the subsystem: `_PdAdapterAcquireSubsystem(..., DSPCounterTimer, 1)`
(use the predefined `DSPCounterTimer` constant as a subsystem identifier)

2. Disable counters—Perform this step if any chance exists that the counters were previously enabled. Doing so is important because the counters might continue to operate independently for the application that initially started them.

`_PdDspCtEnableCounter(..., DCT_UCTx, FALSE)`

where `DCT_UCTx` is a counter-number constant in the range `DSP_UCT0` to `DSP_UCT2`.

3. Load the prescaler (if any of the counters need it)—The prescaler is a 21-bit counter that predivides the input frequency before feeding it to the DSP counters. It can use the following sources: any of the counters' TIOx pins, or one-half the internal DSP clock (66 MHz / 2 = 33 MHz standard; 100 MHz / 2 = 50 MHz on -HS models).

`_PdDspPSLoad(..., dwDivider, dwSource)`

use the `M_PS_xx` constants for the prescaler source

4. Get a private counter/timer event handler from the PowerDAQ driver and set the event with the driver, if required

`_PdUctSetPrivateEvent(..., &hEvent)`

`_PdSetUserEvents(..., CounterTimer, dwEvents0;`

where `dwEventsNotify` is an ORed combination of `eUct0Event`, `eUct1Event` and `eUct2Event`.

5. Enable interrupts from the board if the user application requires interrupts from the counter

`_PdAdapterEnableInterrupt(..., TRUE)`

6. Program the DSP counters/timers using wrapper functions

```
_PdDspCtLoad();  
Load all required registers and set different mode flags  
_PdDspCtEnableCounter(..., DCT_UCT, TRUE);  
Enable the selected counter
```

7. Process events from the counter

```
WaitForSingleObject(hEvent, dwTimeOut)
```

Note Non-Windows OSs should use OS-specific synchronization functions such as *_PdWaitForEvent()* in Linux

8. Get and re-enable events

```
_PdGetUserEvents(..., CounterTimer, &dwEvt)  
Parse the dwEvt bit mask to look for the Uct0Event, eUct1Event or eUct2Event  
event flags  
_PdSetUserEvents(..., CounterTimer, dwEvents)
```

9. Disable all used counters

```
_PdDspCtEnableCounter(..., DCT_UCT, FALSE);  
_PdDspCtLoad(..., DCT_UCT, 0, 0, 0, 0, 0, 0);
```

10. Stop this process

```
_PdUCTClearPrivateEvent(..., hEvent);  
Release the subsystem
```

```
_PdAdapterAcquireSubsystem()  
Release the named subsystem for use  
(if you set dwAcquire = 0)
```

```
_PdAdapterClose()  
Close the adapter
```

```
PdDriverClose()  
Close the driver
```

Note If the application uses more than one counter, you should use all counter-oriented functions (load/enable) individually for each one. You can omit event processing if the user application does not require it.

Note The following C-language examples that illustrate usage of the DSP counter/timers are provided with the PowerDAQ SDK:

- `pdct_dsp.c` highlights basic timer programming.

8. Software Support

PowerDAQ SDK Structure

The SDK installation creates the following directory structure in the folder Program Files (assuming you selected default SDK installation). This software ships on the PowerDAQ Software Suite CD-ROM that accompanies each board.

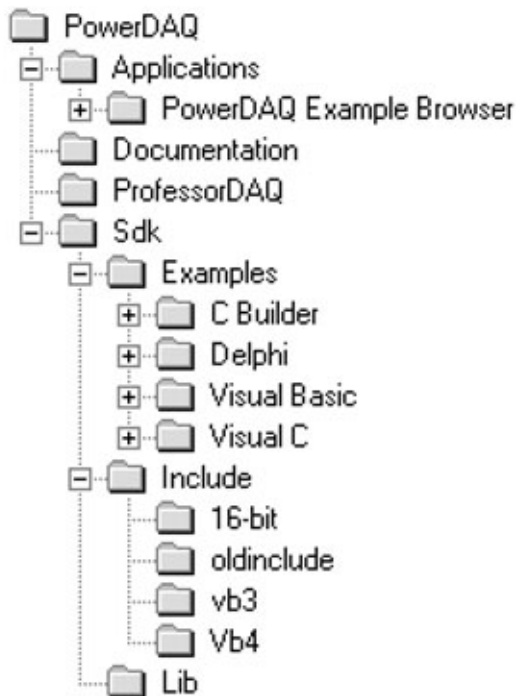

Figure 8.1—PowerDAQ Software Structure

Windows device drivers

Windows NT

\winnt\system32\drivers pwrdaq.sys

Windows 2000

\winnt\system32\drivers PwrDAQ2K.sys

\winnt\inf PwrDAQ2K.inf

Windows XP

\windows\system32\drivers PwrDAQ2K.sys

\windows\inf PwrDAQ2K.inf

Windows DLLs

The PowerDAQ Software Suite includes various DLLs (dynamic linked libraries) for different versions of the Windows operating system. The location of these DLLs is as follows:

Windows NT/2000

\winnt\system32 PwrDAQ32.dll

PwrDAQ16.dll

Windows XP

\windows\system32 PwrDAQ32.dll

PwrDAQ16.dll

The DLLs have identical names for Windows NT/2000/XP, but note that they are implemented differently. All support the same API, so PowerDAQ applications that don't use functions specific to the OS should run on any version of Windows.

Language libraries

PowerDAQ SDK contains libraries for all major software development tools.

/lib

| | |
|--------------|------------------------------|
| pwrdaq32.lib | MSVC/MSVS v.5.x, 6.x |
| pd32bb.lib | Borland C Builder v.3.0, 4.0 |
| pd16bb.lib | 16-bit Borland compilers |
| pwrdaq16.lib | 16-bit MSVC 1.5x |

Include files

/include

| | |
|------------------|--|
| aliases.bas | auxiliary functions to access PowerDAQ structures from within VB |
| DAQDefs.bas | DAQ constant and variable definitions file for Visual Basic |
| DAQDefs.pas | DAQ constant and variable definitions file for Delphi |
| pdApi.bas | module used in SimpleTest VB example |
| pd_dsp_ct.h | DSP counter-timer register definitions file for C/C++ |
| pd_dsp_ct.pas | DSP counter-timer register definitions file for Delphi |
| pd_dsp_es.h | ESSI port register definitions file for C/C++ |
| pd_dsp_es.pas | ESSI port register definitions file for Delphi |
| pd32hdr.h | PowerDAQ DLL driver interface function definitions file for C\C++ |
| pd32hdr.pas | PowerDAQ DLL driver interface function definitions file for Delphi |
| pdfw_bitsdef.bas | PowerDAQ Firmware Command definitions file for Visual Basic |
| pdfw_bitsdef.pas | PowerDAQ Firmware Command definitions file for Delphi |
| pdfw_def.h | firmware constant definition file for C/C++ |
| pdfw_def.pas | firmware constant definition file for Borland Delphi |
| pdfw_def.bas | firmware constant definition file for Visual Basic |
| pd_hcaps.h | boards capabilities definition file for C/C++ |
| pd_hcaps.pas | PowerDAQ Firmware PCI interface definitions file for Visual Basic |
| pdpcidef.h | PowerDAQ Firmware PCI interface definitions file for C\C++ |
| pdpcidef.pas | PowerDAQ Firmware PCI interface definitions file for Delphi |

| | |
|------------------------|--|
| pwrdaq.h | driver constants and definitions file for C/C++ |
| pwrdaq.pas | driver constants and definitions file for Delphi |
| pwrdaq.bas | driver constants and definitions file for Visual Basic |
| pwrdaq32.h | API function prototypes and structures file for C |
| pwrdaq32.hpp | API function prototypes and structures file for C++ |
| pwrdaq32.pas | API function prototypes and structures file for Delphi |
| pwrdaq32.bas | API function prototypes and structures file for Visual Basic |
| pxi.bas | PXI related function definitions file for Visual Basic |
| pxi.h | PXI related function definitions file for C\C++ |
| sigproc.h | PowerDAQ FFT and windows routines definition file for C |
| sigproc.hpp | PowerDAQ FFT and windows routines definition file for C++ |
| vbdll.bas | auxiliary functions to access PowerDAQ buffer from within VB |
| /include/vb3 | |
| pwrdaq16.bas | API function prototypes and structures file for Visual Basic v.3.0 |
| pdfw_def.bas | firmware constant definition file for Visual Basic v.3.0 |
| pd_hcaps.bas | boards capabilities definition file for Visual Basic v.3.0 |
| daqdefs.bas | event word definition for Visual Basic v.3.0 |
| /include/16-bit | |
| pwrdaq16.h | API function prototypes and structures file for 16-bit C/C++ |
| pwrdaq.h | driver constants and definitions file for 16-bit C/C++ |
| pdd_vb3.h | auxiliary functions to access PowerDAQ structures from within VB v.3.0 |
| pd_hcaps.h | boards capabilities definition file for 16-bit C |

Linux support

The PowerDAQ API for Linux, which also supports two variations of realtime Linux (the kernels from RTAI and FSMLabs) is very similar to the Windows API.

Note that under Linux it is possible to have different processes use different subsystems on the same board (adapter).

Kernel driver:

/lib/modules/<kernel_version>/misc/pwrdaq.o

Shared library:

/usr/local/lib/libpowerdaq32.so.1.0

Header files:

| | |
|-----------------|---|
| win_sdk_types.h | datatype definitions needed by the files above. |
| pdfw_def.h | firmware constant definition file for C/C++ |
| powerdaq.h | driver constants and definitions file for C/C++ |
| powerdaq32.h | API function prototypes and structures file for C/C++ |

QNX support

QNX driver:

/usr/bin/dev-pwrdaq

Shared library:

/usr/lib/libpwrdaq.so
/usr/lib/libpowerdaq32.so

Header files:

| | |
|---------------|---|
| pdl_headers.h | header files specific to QNX6 and QNX4 |
| powerdaq.h | driver constants and definitions file for C/C++ |
| powerdaq32.h | API function prototypes and structures file for C/C++ |
| pdfw_def.h | firmware constant definition file for C/C++ |
| win2qnx.h | DDK types conversion into QNX types. |

Example programs

The PowerDAQ Software Suite contains a large set of self-documented examples dedicated to PowerDAQ AO board programming. The best way to write your own program is to start with a ready-to-run example and modify it as required by your application.

The examples are available in C, C++, Delphi and VisualBASIC:

- Single-update example: *pdao_out* (a separate example is available for the PD2-AO-96/16 board, *AO96SimpleIO*)
- Buffered-output example: *pdao_buf* (all buffered modes)

Please refer to the examples' source code for programming details.

All examples are located in:

<Program Files Dir>\PowerDAQ\SDK\Examples\<Language>\<Example>

Third-party software support

The PowerDAQ Software Suite CD contains drivers for most popular third-party software packages. The installation procedure automatically detects if you have installed any of the third-party packages, and it installs the drivers and examples automatically. If you install a third-party software package after installing the PowerDAQ software, you must reinstall our software to include support for this new third-party package.

As of the writing of this manual, we support the following third-party software:

| <i>Software Package</i> | <i>Version</i> | <i>Supports multiple PowerDAQ boards</i> | <i>What's included</i> |
|--|-----------------------|--|---|
| <i>LabVIEW</i> | <i>6.x or greater</i> | <i>Yes</i> | <i>Extensive VIs including click-and-replace low-level VIs</i> |
| <i>LabVIEW for Linux</i> | <i>6.x or greater</i> | <i>Yes</i> | <i>VIs that mirror standard LabVIEW support but run under Linux</i> |
| <i>LabVIEW Real-Time</i> | <i>6.x or greater</i> | <i>Yes</i> | <i>VIs that mirror standard LabVIEW support but run under this environment.</i> |
| <i>Agilent VEE</i> | <i>6.x or greater</i> | <i>Yes</i> | <i>Examples</i> |
| <i>DASyLab</i> | <i>7.x or greater</i> | <i>No</i> | <i>Examples</i> |
| <i>TestPoint</i> | <i>4.0 or greater</i> | <i>Yes</i> | <i>Examples</i> |
| <i>LabWindows/CVI</i> | <i>6.x or greater</i> | <i>Yes</i> | <i>Callable from our VC++ support</i> |
| <i>DIADEM</i> | <i>6.x or greater</i> | <i>Yes</i> | <i>Examples</i> |
| <i>MATLAB Data-Acquisition Toolbox</i> | <i>6.x or greater</i> | <i>Yes</i> | <i>Examples</i> |
| <i>xPC Target</i> | <i>2.x or greater</i> | <i>Yes</i> | <i>Examples</i> |

Table 8.1—Third-party software support

Note If you have an earlier version of a particular applications package than what is listed above, we likely have an earlier version of our driver that works with it. Check with customer support, tell them exactly which software application and version you are running, and ask them if they can locate a legacy version of the driver that is compatible.

LabVIEW VIs for analog output

The PowerDAQ Software Suite comes with a number of LabVIEW VIs that allow you to program an AO Series card from that environment. This section gives an overview of the VIs (both low and intermediate level) that come with our support package.

Low-level VIs

PD AO Buffer Config.vi

Allocates memory for an analog-output buffer.

PD AO Buffer Write.vi

Writes analog-output data to buffers created by the *PD AO Buffer Config* VI.

PD AO Clock Config.vi

Configures an update or interval clock for analog outputs.

PD AO Control.vi

Starts, pauses, resumes, and clears analog-output tasks.

PD AO Group Config.vi

Assigns a list of analog-output channels to a group number and produces the task ID that all other analog-output VIs use.

PD AO Hardware Config.vi

Configures the reference voltage level, output polarity, and the unit of measure (volts or milliamperes) for the data of a given channel.

PD AO Parameter.vi

Sets miscellaneous parameters associated with the analog-output operation of the devices that are not covered with other analog-output VIs.

Intermediate-level VIs

PD AO Buf Len.vi

Configures the length for the regenerated waveform in the DSP output buffer.

PD AO Buf Offs.vi

Configures the start offset for the regenerated waveform in the DSP output buffer.

PD AO Buffered Wave.vi

Advanced and specialized version of *PD AO Wave.vi* that allows the use of an unlimited-size output buffer.

PD AO Clear.vi

Stops any analog-output process, frees resources, clear buffers and returns zero as the taskId.

PD AO Clock Config.vi

Configures an update or interval clock for analog output.

PD AO Config.vi

Configures the upper and lower input limits (reserved for now, $\pm 10V$ fixed output range used) and sets the channel list and acquisition buffer size for the board.

PD AO CV Clk.vi

Configures the output rate of the analog-output subsystem. This VI can be called at any time after *PD AO Start.vi* to dynamically update the acquisition rate.

PD AO DSPMem Wave Config.vi

Sets additional parameters needed for the high-speed waveform generation / regeneration mode from the DSP or on-board memory.

PD AO DSPMem Wave Update.vi

Sets the initial configuration for *PD AO Wave.vi* including frame size, first frame of the output data, regeneration mode and time limit.

PD AO Read Data From File.vi

Reads a specified number of lines or rows from a numeric text file beginning at a specified character offset; it then converts the data to two 1D single-precision/U32 arrays of numbers (scaled data and binary data) .

PD AO Start.vi

Configures the rate and clock source, sets the total number of iterations or continuous mode, and starts the analog-output subsystem.

PD AO SW Trig.vi

Sets additional parameters needed for the high-speed waveform generation / regeneration mode from the DSP or on-board memory.

PD AO Update Channel.vi

Writes a single value to a specified analog-output channel.

PD AO Wait.vi

Checks a waveform-generation task for completion and returns generation status or waits for waveform completion.

PD AO Wave Init.vi

Sets initial configuration for *PD AO Wave.vi* including frame size, first frame of the output data, regeneration mode and time limit.

PD AO Wave.vi

Writes the specified number of scans to the analog output using one of three buffered waveform modes that send the data directly to the DSP on-board output buffer.

PD AO Write One Update.vi

Performs a single update of each channel in the channel list.

PD AO Write.vi

Writes the specified number of scans to the analog output.

Appendix A: Specifications

PDx-AO specifications

The following conditions apply:

$T_A = 0^\circ\text{C}$ to 85°C

Analog-output subsystem

| Parameter | Value | | | |
|------------------------|--|------------------------|--------------------|---------------------------------|
| Number of channels | 8, 16, 32 or 96 (PD2-AO only) | | | |
| Resolution | 16 bits | | | |
| Update rate (kHz) | Board model | Arbitrary channel list | Fixed channel list | Regenerate from on-board memory |
| | PDx-AO-8/16x | 455 | 800 | 800 |
| | PDx-AO-16/16 | 455 | 1600 | 1600 |
| | PDx-AO-16/16HS | 600 | 2200 | 3200 |
| | PDx-AO-32/16, -HC | 455 | 1600 | 1600 |
| | PDx-AO-32/16HS | 600 | 2200 | 3200 |
| | PD2-AO-96/16 | 455 | 1600 | 1600 |
| | PD2-AO-96/16HS | 600 | 2200 | 9600 |
| Buffer Size | 2k samples (upgradeable to 64k samples except on PD2-AO-32/16, -32/16HS - check factory for latest status); 64k samples standard on most -HS boards. | | | |
| Type of D/A | Double-buffered | | | |
| Accuracy | ± 3 LSB max | | | |
| DNL | ± 3 LSB max | | | |
| Monotonicity over temp | 15 bits | | | |
| Gain Error | $\pm 0.1\%$ maximum, $\pm 0.025\%$ typical | | | |
| Range | $\pm 10\text{V}$ fixed; for other fixed ranges contact factory | | | |

Appendix A: Specifications

| | |
|---|--|
| Output Coupling | DC |
| Output Impedance | 1.5 Ω max |
| Current Drive | ± 5 mA (PDXI-AO, PD2-AO-96/16) ± 20 mA (PD2-AO-8/16, -16/16, -32/16) ± 100 mA (PD2-AO-32/16HC) |
| Capacitive Loads | 180 pF min |
| Settling time | 10 μ sec to 0.003% |
| Slew Rate | 10 V/ μ sec |
| Gain Bandwidth | 1 MHz |
| Noise | 2 LSB RMS, 0-10000 Hz |
| Output protection | Short to ground, ± 15 V |
| Power-on state, default, user programmable, stable 200 msec after reset | 0.0000V ± 25 mV (PD2-AO-8/16, -16/16, -32/16) 0.0000V ± 5 mV (PD2-AO-96/16, PDXI-AO) |
| Gain drift | 25 ppm/deg C |

Note Due to the quad D/A used on these boards, the output current is limited. Only one output of each quad can continuously withstand a short to ground. Current is limited to 40 mA for the PD2-AO-8/16, -16/16 and -32/16 boards; the limit is 120 mA for the PD2-AO-32/16HC, and 20 mA for the PDXI/PD2-AO-96/16 models.

Digital Input/Output subsystem

| Parameter | Value |
|--------------------|---|
| Number of channels | 8 inputs and 8 outputs |
| Compatibility | CMOS/TTL, 2 kV ESD protected |
| Power-on state | Logic Zero |
| Input termination | 4.7 k Ω pullup to 5V |
| Output High Level | 3.0V min @ -24 mA, 3.4V min @ -16 mA, 4.2V min @ -2 mA Note: when used in 3.3V PCI bus, digital output voltage is limited to 3.3V |
| Output Low Level | 0.55V max @ 24 mA |
| Input Low Voltage | 0.0 - 0.8 V |
| Input High Voltage | 2.0 - 5.0 V |
| Input current | 1 μ A |

DSP-based subsystems

There are two DSP-based subsystems available on the PowerDAQ AO boards:

- Counter/timers
- High-speed interrupts

DC electrical characteristics for DSP-based subsystems

Counter/timers

| Parameter | Value |
|---------------------|--|
| Number of channels | 3 |
| Resolution | 24 bits |
| Maximum frequency | 16.5 MHz (25 MHz on -HS models) for an external clock 33 MHz (50 MHz on -HS models) for the internal clock (see note) |
| Minimum frequency | DC for input, 0.0000001 Hz for output |
| Minimum Pulse Width | 20 nsec |
| Output High Level | 2.0V min @ -4 mA |
| Output Low Level | 0.5V max @ 4 mA |
| Input Low Voltage | 0.0 - 0.8 V |
| Input High Voltage | 2.0 - 5.0 V |
| Input current | 1 μ A |

Note The external clock frequency should be less than the internal operating frequency divided by 4 (for instance, with a 66-MHz DSP, the value is 16.33 MHz).

The following conditions apply:

$$T_A = 0-100^\circ\text{C}$$

$$C_{\text{load}} = 50 \text{ pF} + 2 \text{ TTL loads}$$

Appendix B: Accessories

UEI supplies a wide range of accessories for the PowerDAQ PD2/PDXI boards. They greatly expand the core functionality of standard AO hardware and allow you to employ these cards in very demanding applications. These accessories also provide the means for implementing custom interconnection schemes for OEM applications.

Screw-Terminal Panels (PD2/PDXI)

| | |
|---|--|
| <i>PD2-AO-STP-16 PDXI-AO-STP-16</i> | <i>16-channel screw-terminal panel for PowerDAQ AO boards.</i> |
| <i>PD2-AO-STP-16KIT PDXI-AO-STP-16KIT</i> | <i>Complete kit: Includes AO-STP-16 and PD-CBL-96 for 8- and 16-channel boards</i> |
| <i>PD2-AO-STP-32 PDXI-AO-STP-32</i> | <i>32-channel screw-terminal panel for PowerDAQ AO boards. This universal screw terminal includes both analog and digital terminals and allows you to connect AO and Sense lines directly at the screw terminal. Can be used with all PowerDAQ AO boards except PD2-AO-96/16 (note that digital part of this screw terminal can still be used in that case).</i> |
| <i>PD2-AO-STP-32KIT PDXI-AO-STP-32KIT</i> | <i>Complete kit: Includes AO-STP-32 and PD-CBL-96 for 8- and 16-channel boards</i> |
| <i>PD-STP-3716</i> | <i>Small 16-channel screw-terminal panel with 37-pin connector provides low-cost termination option for low channel counts. Works with PD-CBL-4037 to connect field wiring for 16 analog outputs to the PD2-AO-96/16 board, which has no bracket-mounted connector.</i> |
| <i>PD-CONN-PCB</i> | <i>Small terminal panel useful in OEM applications, but does not connect to a board's digital signals—used only with PD2-AO-8/16, -16/16 and -32/16.</i> |
| <i>PD-AO-AMP-100</i> | <i>Generates outputs to $\pm 100V$ for 16 analog outputs. Needs power supply (PSU-AO32G115).</i> |

BNC Panels (PD2/PDXI)

| | |
|----------------------|---|
| <i>PD-BNC-16</i> | <i>16-channel BNC panel for AO-8/16 boards only.</i> |
| <i>PD-BNC-16-KIT</i> | <i>Complete kit: Includes PD-BNC-16, PD-CBL-96 and PD-CBL-37</i> |
| <i>PD-BNC-64</i> | <i>64-channel BNC panel for all PowerDAQ AO boards except PD2-AO-96/16.</i> |
| <i>PD-BNC-64-KIT</i> | <i>Complete kit: Includes PD-BNC-64, PD-CBL-96 and PD-CBL-37</i> |

Cables (PD2/PDXI)

| | |
|------------------------|---|
| <i>PDXI-AO-CBL-96</i> | <i>Shielded cable for use only with PDXI AO Series cards. Split cable: at the card you plug in a 96-way connector into J1. At the termination panel, it provides both a 96-way connector for analog signals and a 37-way connector for digital signals.</i> |
| <i>PD-CBL-96-6FT</i> | <i>96-way pinless, round, 6-ft shielded cable with metal cover plates</i> |
| <i>PD-CBL-96-9FT</i> | <i>96-way pinless, round 9-ft shielded cable with metal cover plates</i> |
| <i>PD-CBL-37</i> | <i>DIO cable set: 37-way, D-sub cable, cable with mounting bracket A 13" ribbon cable connects from the AO board's J2 digital connector (DIO/Counters/IRQx) to a 37-way D-sub mounting bracket. A 1m ribbon cable then connects from the bracket to PD-AO-STP panels.</i> |
| <i>PD-CBL-37-6FT</i> | <i>DIO cable set: 37-way, 6-ft D-sub cable, internal cable with mounting bracket</i> |
| <i>PD-CBL-4037</i> | <i>Only for PD2-AO-96/16. 37-way ribbon cable connects from J3-J8 connectors on the board to a 37-way D-sub bracket. A 1m ribbon cable then connects from the bracket to PD-STP-3716 panels.</i> |
| <i>PD-CBL-3650-8/8</i> | <i>DIO cable set: 36/50-way, 1m ribbon cable, internal cable with mounting bracket (for 8 DI and 8 DO signals)</i> |
| <i>PD-CBL-3737</i> | <i>D-sub, 37-way, 1m ribbon cable connects two analog-output amplifiers (PD-AO-AMP-100) to increase the number of channels possible with one panel alone (16 outputs).</i> |

Other Accessories (PD2/PDXI)

| | |
|---------------------|--|
| <i>PSU-AO32G115</i> | <i>Auxiliary power supply, needed with PD-AO-AMP-100 amplification panel.</i> |
| <i>PD-CONN-STR</i> | <i>A vertical pcb-mounted connector from Fujitsu that mates with a 96-pin connector. Offered to customers who need connectors on their boards or systems that match the connector on the PD2 AO Series cards and so they can use our existing cables.</i> |
| <i>PD-CONN-RTA</i> | <i>A right-angle pcb-mounted connector from Fujitsu that mates with a 96-pin connector. Offered to customers who need connectors on their boards or systems that match the connector on the PD2 AO Series cards and so they can use our existing cables.</i> |

OEM Header Distribution Connector

For OEMs, the AO Series boards provide the PD-CONN-PCB, a small terminal panel that allows them to connect the PD2-MF/MFS and PD2-AO/PDXI-AO boards. Normally you get a board only with the connector and thus use it in custom embedded configurations. As an option (contact the factory) you can order a bracket that allows the panel to mount to a PC's rear chassis (as shown in Figure B.1) See Table B.1 for the pinout conversion between the PD2-MFx and PD2-AO cards.

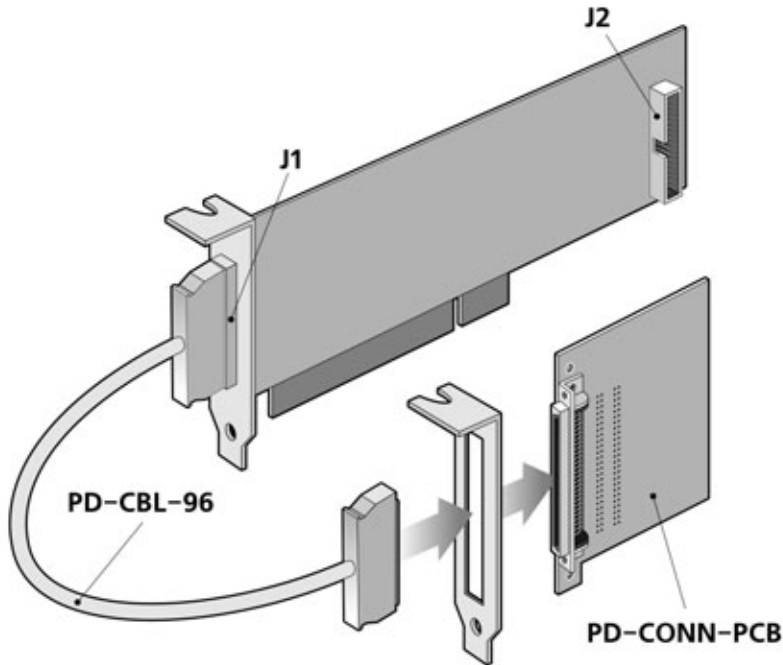

Figure B.1—Connecting the PD-CONN-PCB panel to an AO Series card (note that the bracket for attaching a panel to a PC's rear slots is optional).

| PD2-MFx | PD2-AO-32/16 | J1 Pin | J1 Pin | PD2-AO-32/16 | PD2-MFx |
|--------------|---------------|-----------|-----------|---------------|-------------|
| AGND | AGND | 1 | 49 | AGND | AGND |
| AGND | AGND | 2 | 50 | AGND | AOUT0 |
| AGND | AGND | 3 | 51 | AGND | AGND |
| AGND | AGND | 4 | 52 | AGND | AOUT1 |
| DGND | DGND | 5 | 53 | AGND | AGND |
| AGND | AGND | 6 | 54 | AGND | AGND |
| AIN55 | AOUT31 | 7 | 55 | AOUT30 | AIN54 |
| AIN53 | AOUT29 | 8 | 56 | AOUT28 | AIN52 |
| AIN51 | AOUT27 | 9 | 57 | AOUT26 | AIN50 |
| AIN49 | AOUT25 | 10 | 58 | AOUT24 | AIN48 |
| AGND | AGND | 11 | 59 | AOUT23 | AIN39 |
| AIN38 | AOUT22 | 12 | 60 | AOUT21 | AIN37 |
| AIN36 | AOUT20 | 13 | 61 | AOUT19 | AIN35 |
| AIN34 | AOUT18 | 14 | 62 | AGND | AGND |
| AIN33 | AOUT17 | 15 | 63 | AOUT16 | AIN32 |
| AIN23 | AOUT15 | 16 | 64 | AOUT14 | AIN22 |
| AIN21 | AOUT13 | 17 | 65 | AOUT12 | AIN20 |
| AGND | AGND | 18 | 66 | AOUT11 | AIN19 |
| AIN18 | AOUT10 | 19 | 67 | AOUT9 | AIN17 |
| AIN16 | AOUT8 | 20 | 68 | AOUT7 | AIN7 |
| AIN6 | AOUT6 | 21 | 69 | AGND | AGND |
| AIN5 | AOUT5 | 22 | 70 | AOUT4 | AIN4 |
| AIN3 | AOUT3 | 23 | 71 | AOUT2 | AIN2 |
| AIN1 | AOUT1 | 24 | 72 | AOUT0 | AIN0 |
| AGND | AGND | 25 | 73 | AGND | AGND |
| Ext. Trig In | AGND | 26 | 74 | AGND | +5V |
| CV Clock Out | AGND | 27 | 75 | AGND | CV Clock In |
| N/C | AGND | 28 | 76 | AGND | AGND |
| AGND | AGND | 29 | 77 | AGND | N/C |
| CL Clock In | AGND | 30 | 78 | AOUT 31 SENSE | AIN63 |
| AIN62 | AOUT 30 SENSE | 31 | 79 | AOUT 29 SENSE | AIN61 |
| AIN60 | AOUT 28 SENSE | 32 | 80 | AGND | AGND |
| AIN59 | AOUT 27 SENSE | 33 | 81 | AOUT 26 SENSE | AIN58 |
| AIN57 | AOUT 25 SENSE | 34 | 82 | AOUT 24 SENSE | AIN56 |
| AIN47 | AOUT 23 SENSE | 35 | 83 | AOUT 22 SENSE | AIN46 |
| AGND | AGND | 36 | 84 | AOUT 21 SENSE | AIN45 |
| AIN44 | AOUT 20 SENSE | 37 | 85 | AOUT 19 SENSE | AIN43 |
| AIN42 | AOUT 18 SENSE | 38 | 86 | AOUT 17 SENSE | AIN41 |
| AIN40 | AOUT 16 SENSE | 39 | 87 | AOUT 15 SENSE | AIN31 |
| AGND | AGND | 40 | 88 | AOUT 14 SENSE | AIN30 |
| AIN29 | AOUT 13 SENSE | 41 | 89 | AOUT 12 SENSE | AIN28 |
| AIN27 | AOUT 11 SENSE | 42 | 90 | AOUT 10 SENSE | AIN26 |
| AIN25 | AOUT 9 SENSE | 43 | 91 | AGND | AGND |
| AIN24 | AOUT 8 SENSE | 44 | 92 | AOUT 7 SENSE | AIN15 |
| AIN14 | AOUT 6 SENSE | 45 | 93 | AOUT 5 SENSE | AIN13 |
| AIN12 | AOUT 4 SENSE | 46 | 94 | AOUT 3 SENSE | AIN11 |
| AGND | AGND | 47 | 95 | AOUT 2 SENSE | AIN10 |
| AIN9 | AOUT 1SENSE | 48 | 96 | AOUT 0 SENSE | AIN8 |

Table B.1—Conversion between the PD2-MF(S) and PD2-AO board J1 connector pinout. Use this table when connecting a PDx-AO board to a PD-BNC-16 (PDx-AO-8 only) or a PD-BNC-64 (PDx-AO-16 and PDx-AO-32 boards) terminal panel.

Appendix C: Board-level AO Command Format

This section describes commands on the PowerDAQ AO boards that can be used for low-level firmware or software programming (in non-buffered mode). They also serve to help you better understand AO board functionality.

Some of the commands have a different format based on the board families. Note in the following discussion that SDF refers to the Standard Density Format cards (those with as many as 32 analog outputs) and HDF refers to High Density Format cards (with 96 channels).

The list below defines a set of available low-level AO commands. The user can directly execute any of them by calling the `_PdDIO256CmdRead()` or `_PdDIO256CmdWrite()` SDK functions.

Any of those command can execute with two Wait states on the DSP bus; however the PD2-AO-8/16, -16/16 and -32/16 require seven Wait states according to the timing requirements of the DAC7644 D/A converter they use.

The available commands are:

- WRU—Write to the specified DAC and update it. If the DAC number is the same as the Update All channel number, then all the DACs on the board are updated with old/new values if the Hardware Simultaneous Update method is enabled
- WRH—Write to the specified DAC and hold that value (the DAC continues to output the previously written value). If the DAC number is the same as the Update All channel number, then all DACs on the board including the one just written to are updated with old/new values if the Hardware Simultaneous Update method is enabled
- WRA—Write to the specified DAC and update all DACs regardless of the status of any update mode
- UAL—Update all DACs regardless of the status of their update mode
- CFG—Set a new configuration word (update the mode and the Update All channel)
- CFC—Set a new clock-configuration (for HDF boards only)
- DIN—Read a digital input
- DOU—Write a digital output

The DSP has a 24-bit address space. The standard-density cards use the base address + 7 LSBs in this address space; the high-density cards use 9 LSBs and two different base addresses for access:

Appendix C: Board-level AO Command Format

BA1 (base address 1)—0xFC0000, the DSP verifies only 6 MSBs
 BA2 (base address 2)—0xBFF000, the DSP verifies only 12 MSBs

C4-C0—channel number for a SDF card

C6-C0—channel number for a HDF card

XTE—HDF cards only, external trigger enable (1 = enable)

XCE—HDF only, external clock enable (1 = enable)

XTP—HDF only, external trigger polarity (1 = invert incoming signal)

XCP—HDF only, external clock polarity (1 = invert incoming signal)

UEN—hardware simultaneous update method enable (0 = enable)

U4-U0—Update All channel number for SDF boards

U6-U0—Update All channel number for HDF boards

For the WRU, WRA and WRH commands, 16 LSBs on the DSP data bus contains DAC data; for the DIN and DOU commands, 8 LSBs on the DSP data bus contains DIO data.

| | Family | Base | A8 | A7 | A6 | A5 | A4 | A3 | A2 | A1 | A0 | R/W | Example |
|-----|--------|------|----|-----|----|-----|----|-----|-----|-----|-----|-----|--------------|
| WRU | SDF | BA1 | x | x | 0 | 0 | C4 | C3 | C2 | C1 | C0 | W | 0xFC0000+Ch# |
| | HDF | BA1 | x | 0 | C6 | C5 | C4 | C3 | C2 | C1 | C0 | W | 0xFC0000+Ch# |
| DIN | SDF | BA1 | x | x | 0 | 1 | 1 | 0 | 1 | 0 | 0 | W | 0xFC00B4 |
| | HDF | BA2 | 1 | 0 | 0 | 0 | 0 | 0 | 0 | 0 | 0 | W | 0xBFF100 |
| WRA | SDF | BA1 | x | x | 1 | 0 | C4 | C3 | C2 | C1 | C0 | W | 0xFC0040+Ch# |
| | HDF | n/a | | | | | | | | | | - | |
| WRH | SDF | BA1 | x | x | 1 | 1 | C4 | C3 | C2 | C1 | C0 | W | 0xFC0060+Ch# |
| | HDF | BA1 | x | 1 | C6 | C5 | C4 | C3 | C2 | C1 | C0 | W | 0xFC0080+Ch# |
| CFC | SDF | n/a | | | | | | | | | | - | |
| | HDF | BA2 | 1 | 1 | x | x | x | XCP | XTP | XCE | XTE | W | 0xBFF180+CFC |
| UAL | SDF | BA1 | x | x | 0 | 0 | x | x | x | x | x | R | 0xFC0000 |
| | HDF | BA1 | x | 0 | x | x | x | x | x | x | x | R | 0xFC0000 |
| DOU | SDF | BA1 | x | x | 0 | 1 | 1 | 0 | 1 | 0 | 1 | R | 0xFC00B4 |
| | HDF | BA2 | 1 | 0 | 0 | 0 | 0 | 0 | 0 | 0 | 0 | R | 0xBFF100 |
| CFG | SDF | BA1 | x | x | 1 | UEN | U4 | U3 | U2 | U1 | U0 | R | 0xFC0040+CFG |
| | HDF | BA2 | 0 | UEN | U6 | U5 | U4 | U3 | U2 | U1 | U0 | W | 0xBFF000+CFG |

Table C.1—AO Series low-level command summary

Single-Point Update commands

The Single-Point Update mode is compatible with any of the buffered modes, but it should not update channels that are updated in the buffered mode. Timing is not guaranteed in the Single-Point Update mode, but a realtime OS, if used, can pace it.

Address space/commands

Two SDK functions provide direct access to AO and control registers:

`_PdDIO256CmdRead` and `_PdDIO256CmdWrite`

when supplied with the proper address and data.

All analog-output registers are located starting at the base address 0xFC0000 in the local PowerDAQ board address space. Control/DIO register for a HDF card are located at base address 0xBFF000.

```
;*****
; AO Register Definitions
;*****
AO_WR          equ      $0000000    ; Write AO DAC + WR
AO_PROP        equ      $0000040    ; Update all DACs + WR
AO_PROPALL     equ      $0000000    ; Update all DACs + RD
AO_WRHOLD      equ      $0000060    ; Write&hold DACs + WR
AO96_WRHOLD    equ      $0000080    ; PD2-AO-96/16 only Write&hold DACs + WR
AO_REG0        equ      $0FC0000    ; AO Registers
AO_REG1        equ      $0FC0001    ;
. .
AO_REG95       equ      $0FC005F    ;
AO_CFG         equ      $0FC0040    ; AO32 Update Mode Configuration register + R
```

Also the PD2-AO-96/16 uses addresses starting from 0xBFF000 for the control register(s).

```
PD_AO96Cfg     equ      $0BFF000    ; AO96 Update Mode Configuration register + W
PD_DIOData96   equ      $0BFF100    ; DIn/DOut Access Register R/W
PD_AO96ClkCfg  equ      $0BFF180    ; AO96 Clock configuration register + W
```

Non-buffered mode control bits

You can perform a non-buffered update of any available DACs at any time irregardless if any buffered mode is already selected. The analog-output data format is a 32-bit DWORD where individual bits are defined as follows:

Write commands

- PD2/PDXI AO boards (except PD2-AO-96/16)

Bits 0-15—Output data, where 0x0000 is -10V and 0xFFFF is +10V

Bits 16-20—Output channel number (0-31)

Bit 21—Write&Hold flag. If set to 1, the selected channel does not update the output with new data until you issue the Update All command (or the Write and Update command for the same quad)

Bit 22—Update All flag. When set to 1, all channels previously written with Write&Hold flags are updated.

Bits 23-31—unused, must be filled with Zeroes.

- PD2-AO-96/16 board

Output to 0xFC0000 + REG# commands

Bits 0-15—Output data, where 0x0000 is -10V and 0xFFFF is +10V

Bits 16-22—Output channel number (0-95)

Bit 23—Write&Hold/Update All flag. If set to 1, the selected channel does not update its output with the new data until you issue the Update All command. When set to 0, all channels previously written with a Write&Hold flag are updated.

DIO Read/Write command

A read or write to/from address 0xBFF100 provides access to an AO card's DIO port. The firmware automatically redirects DIO function-call access to this address

Clock Configuration command

A write to address 0xBFF180 | IRQBTRIG | EXTCLK configures the clock mode.

XTE = 0x1

This command allows you to safely assert the IRQB line when the external Update All mode is required. You must apply the external update signal to the EXTRIGIN terminal.

XCE = 0x2

This command switches the source of the TMR2 pin to the EXTCLKIN terminal, gated by EXTGATEIN terminal.

Set Update All channel command

To set the Update All channel, make a write to address (0xBFF000 | REG | UPDATE) where REG is register number (0-95) and UPDATE is the Update Enable flag (0x100 = enable). This command tells the AO board's logic which channel, when written to, should cause an update of all channels. If the UPDATE field is set to 0, the board disables this feature and it decodes only bits in the write commands.

Note Always disable the Update All channel feature when using individual bits to define the update mode in the write commands.

Read commands

- PD2/PDXI AO boards (except PD2-AO-96/16)

Two read commands are defined for these boards:

Update All command

A **read** from address 0xFC0000 updates all channels. Read from this address is intercepted by the on-board logic and translated into update all channels strobe.

Set Update All channel command

To set the Update All channel, **read** from address 0xFC0040 | REG | UPDATE where REG is register number, and UPDATE is the Update Enable flag (0x20 = enable). This command tells the AO board's logic which channel will result in an update of all channels. If the UPDATE field is set to 0, the board disables this feature and it decodes only bits in the write commands.

Note Always disable the update channel feature when using individual bits to define the update mode in the write analog output commands.

- PD2-AO-96/16 board

One read commands is defined for this board:

Update All command

A read from address 0xFC0000 updates all channels. Read from this address is intercepted by the on-board logic and translated into update all channels strobe.

Call-sequence example

Two steps are required to properly use a PowerDAQ AO board (assuming that the open/close operations for the driver, adapter and subsystem are already done in the code)

1. Disable or enable the Update All channel on the PDX-AO-8/16,-16/16 or -32/16 board (the choice depends on the simultaneous/sequential-update requirement)
2. Write AO data

Using AO functions of the SDK

1. Call `_PdAO32SetUpdateChannel(...WORD wChannel, BOOL bEnable)`
2. Call `_PdAO32WriteHold(...WORD wChannel, WORD wValue)` for all channels you want to update, including the Update All channel, or use `_PdAO32Write()` for all channels that require an immediate update

Note For the 96-channel HDF board, use the xx96xx functions.

Using `_PdDIO256RegXX` functions

1. Call `_PdDIO256RegRead(...,0xFC0040,...)` to disable simultaneous updates; or call `_PdDIO256RegRead(...,0xFC0060|UpCH,...)` to enable that feature.
2. Combine AO data with the Write&Hold bit
channel = 6;
dwAddr = (0xFC0000) | (channel <<16) | HoldBit;
HoldBit = 0x60 or 0x0 if not used
dwData = (hexDataOut) ;
`_PdDIO256RegWrite (... ,dwAddr,dwData);`

Appendix D: Calibration

UEI performs calibration on all PDx-AO Series products prior to shipping them to the customer. This calibration is performed with a NIST-traceable test fixture. The Calibration subsystem is not directly available to the user.

The following structure holds calibration values along with other nonvolatile information

```
typedef struct _PD_EEPROM
{
    union
    {
        struct _Header
        {
            UCHAR    ADCFifoSize;
            UCHAR    CLFifoSize;
            UCHAR    SerialNumber[PD_SERIALNUMBER_SIZE];
            UCHAR    ManufactureDate[PD_DATE_SIZE];
            UCHAR    CalibrationDate[PD_DATE_SIZE];
            ULONG    Revision;
            USHORT   FirstUseDate;
            USHORT   CalibrArea[PD_CAL_AREA_SIZE];
            USHORT   FWModeSelect;
            USHORT   StartupArea[PD_SST_AREA_SIZE];
            USHORT   PXI_Config[5];
            UCHAR    DACFifoSize;
        } Header;

        USHORT WordValues[PD_EEPROM_SIZE];
    } u;
} PD_EEPROM, *PPD_EEPROM;
```

Appendix D: Calibration

In the above structure, the CalibrArea array holds data for as many as eight calibration ICs (each is an AD8801, an octal 8-bit trimming DAC). These ICs are numbered 0-7, and their internal calibration DACs are likewise numbered 0-7 (the schematics refer to them as V1-V8).

The calibration data structure is an array of 16-bit unsigned integers where each member of the array holds hex data for two 8-bit DACs. The data is assigned to the various DACs as shown in Table D.1.

| Dac IC# | CalDAC | Index | CalDAC | Index | CalDAC | Index | CalDAC | Index |
|---------|--------|-------|--------|-------|--------|-------|--------|-------|
| DAC IC0 | V2V1 | 0 | V4V3 | 1 | V6V5 | 2 | V8V7 | 3 |
| DAC IC1 | V2V1 | 4 | V4V3 | 5 | V6V5 | 6 | V8V7 | 7 |
| DAC IC2 | V2V1 | 8 | V4V3 | 9 | V6V5 | 10 | V8V7 | 11 |
| DAC IC3 | V2V1 | 12 | V4V3 | 13 | V6V5 | 14 | V8V7 | 15 |
| DAC IC4 | V2V1 | 16 | V4V3 | 17 | V6V5 | 18 | V8V7 | 19 |
| DAC IC5 | V2V1 | 20 | V4V3 | 21 | V6V5 | 22 | V8V7 | 23 |
| DAC IC6 | V2V1 | 24 | V4V3 | 25 | V6V5 | 26 | V8V7 | 27 |
| DAC IC7 | V2V1 | 28 | V4V3 | 29 | V6V5 | 30 | V8V7 | 31 |

Table D.1—Calibration data assignments held in the CalibrArea array.

For example, if CalibrArea[10] has value of 0xAB56, then DAC V6 that is internal to IC2 is written with 0xAB, and DAC V5 of the same IC is written with 0x56.

Values for all DACs on all the calibration ICs are restored by the PowerDAQ driver during the driver initialization process.

Calibration IC and DAC assignments

Note If you choose not to use all the onboard channels listed in the tables below, you should write their DACs with 0x80.

- PD2-AO-8/16, -16/16, -32/16

IC₀ Calibrate AOut Ch 0-3
V1 AOut 0 offset
V2 AOut 1 offset
V3 AOut 2 offset
V4 AOut 3 offset
V5 negative -10V rail (gain)
V6 positive +10V rail (gain)

-
- V7, V8 reserved, should be written with 0x80
- IC₁ Calibrate AOut channels 4-7
- V1 AOut 4 offset
 - V2 AOut 5 offset
 - V3 AOut 6 offset
 - V4 AOut 7 offset
 - V5 negative -10V rail (gain)
 - V6 positive +10V rail (gain)
 - V7, V8 reserved, should be written with 0x80
- IC₂ Calibrate AOut channels 8-11
- V1 AOut 8 offset
 - V2 AOut 9 offset
 - V3 AOut 10 offset
 - V4 AOut 11 offset
 - V5 negative -10V rail (gain)
 - V6 positive +10V rail (gain)
 - V7, V8 reserved, should be written with 0x80
- IC₃ Calibrate AOut channels 12-15
- V1 AOut 12 offset
 - V2 AOut 13 offset
 - V3 AOut 14 offset
 - V4 AOut 15 offset
 - V5 negative -10V rail (gain)
 - V6 positive +10V rail (gain)
 - V7, V8 reserved, should be written with 0x80
- IC₄ Calibrate AOut channels 16-19
- V1 AOut 16 offset
 - V2 AOut 17 offset
 - V3 AOut 18 offset
 - V4 AOut 19 offset
 - V5 negative -10V rail (gain)
 - V6 positive +10V rail (gain)
 - V7, V8 reserved, should be written with 0x80
- IC₅ Calibrate AOut channels 20-23
- V1 AOut 20 offset
 - V2 AOut 21 offset
 - V3 AOut 22 offset
 - V4 AOut 23 offset
 - V5 negative -10V rail (gain)
 - V6 positive +10V rail (gain)
 - V7, V8 reserved, should be written with 0x80

Appendix D: Calibration

IC₆ Calibrate AOut channels 24-27
V1 - AOut 24 offset
V2 - AOut 25 offset
V3 - AOut 26 offset
V4 - AOut 27 offset
V5 - negative -10V rail (gain)
V6 - positive +10V rail (gain)
V7,V8 -reserved, unused should be written with 0x80

IC₇ Calibrate AOut channels 28-31
V1 AOut 28 offset
V2 AOut 29 offset
V3 AOut 30 offset
V4 AOut 31 offset
V5 negative -10V rail (gain)
V6 positive +10V rail (gain)
V7, V8 reserved, should be written with 0x80

- PD2-AO-96/16

IC₀ Calibrate AOut channels 0-15,16-31

- V1 AOut 0-15 negative -10V rail adjust up
- V2 AOut 0-15 negative -10V rail adjust down
- V3 AOut 0-15 positive +10V rail adjust up
- V4 AOut 0-15 positive +10V rail adjust down
- V5 AOut 16-31 negative -10V rail adjust up
- V6 AOut 16-31 negative -10V rail adjust down
- V7 AOut 16-31 positive +10V rail adjust up
- V8 AOut 16-31 positive +10V rail adjust down

IC₁ Calibrate AOut channels 32-47, 48-63

- V1 AOut 32-47 negative -10V rail adjust up
- V2 AOut 32-47 negative -10V rail adjust down
- V3 AOut 32-47 positive +10V rail adjust up
- V4 AOut 32-47 positive +10V rail adjust down
- V5 AOut 48-63 negative -10V rail adjust up
- V6 AOut 48-63 negative -10V rail adjust down
- V7 AOut 48-63 positive +10V rail adjust up
- V8 AOut 48-63 positive +10V rail adjust down

IC₂ Calibrate AOut channels 64-79, 80-95

- V1 AOut 64-79 negative -10V rail adjust up
- V2 AOut 64-79 negative -10V rail adjust down
- V3 AOut 64-79 positive +10V rail adjust up
- V4 AOut 64-79 positive +10V rail adjust down
- V5 AOut 80-95 negative -10V rail adjust up
- V6 AOut 80-95 negative -10V rail adjust down
- V7 AOut 80-95 positive +10V rail adjust up
- V8 AOut 80-95 positive +10V rail adjust down

- PD2-AO-32/16HC

IC₁ Calibrate AOut channels 0-15,16-31

- V1 AOut 0-15 negative -10V rail adjust up
- V2 AOut 0-15 negative -10V rail adjust down
- V3 AOut 0-15 positive +10V rail adjust up
- V4 AOut 0-15 positive +10V rail adjust down
- V5 AOut 16-31 negative -10V rail adjust up
- V6 AOut 16-31 negative -10V rail adjust down
- V7 AOut 16-31 positive +10V rail adjust up
- V8 AOut 16-31 positive +10V rail adjust down

Appendix E: Advanced Circular Buffer

The Advanced Circular Buffer (ACB) solves many of the problems associated with high-throughput data acquisition/output on a multithreaded /multitasking operating system. For simplicity, data acquisition as an input process is discussed here. However, the same concepts can be applied to output-signal generation.

- Asynchronous operation
- Nondeterministic processor time slots per thread
- Dynamic processor loading
- Nondeterministic user operation

The ACB requires that the DAQ interface library allocate a large circular buffer in the application's memory space. The buffer size must be no larger than the available physical memory with sufficient physical memory left over for most of the executable portion of the OS and active applications to reside in memory. This prevents code or data from frequently being swapped to disk. Consequently, if continuous gap-free acquisition is to be performed, the buffer should be large enough to hold all the acquired data for the maximum time period expected between application execution latency and the time required for the application to process all data in a full buffer. This also implies that the application must be able to process the data at a rate faster than the rate of acquisition.

Once acquisition is started, the DAQ board/driver transfer and store data into the buffer at one rate, and the application generally reads the data from the buffer at another rate. Both operations occur asynchronously of each other.

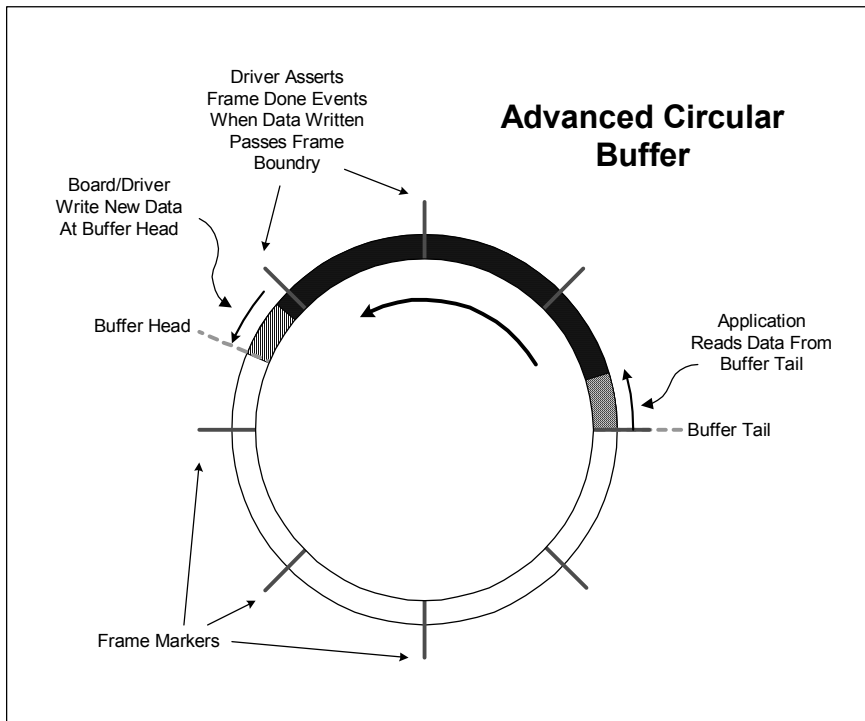

Figure E.1—Advanced Circular Buffer

The application can be synchronized to the acquisition process by either timer notification or by an event from the driver notifying that a certain sample count boundary has been passed.

In order to receive notification on a sample or scan count boundary, the buffer is segmented into frames. Whenever the data transferred to the buffer crosses a frame boundary, the driver sends an event to the application. This event wakes up the application thread that is responsible for processing data in the buffer. To keep the frame boundaries at fixed buffer locations, the buffer size should be a multiple of the frame size. If multichannel acquisition is performed, then the frame size should also be a multiple of the scan size. Doing so keeps the pointer arithmetic from becoming unnecessarily complex.

With the ACB, three modes of operation are possible:

- Single Buffer
- Circular Buffer
- Recycled Circular Buffer

In all three modes, data is written to the beginning of the buffer at the start of acquisition. The three modes differ in what is done when the end of the buffer is reached and if the buffer head catches up with the buffer tail.

Single Buffer

In the Single Buffer mode, acquisition stops when the buffer end is reached. In this mode, the application can access the buffer and process the data any time during acquisition or wait until the buffer is full, and acquisition stops. The Single Buffer mode is the simplest to program, and it's also the most common. It is useful in applications where acquiring data in a continuous stream is not required. This is similar to the way digital multimeters and storage scopes acquire signals, whereby a single buffer is filled and then the waveform is displayed. This process can also be repeated any number of times.

Circular Buffer

In the Circular Buffer mode, the buffer head and tail wrap to the beginning of the buffer when the end is reached. Data is written at the location pointed to by head and the head pointer is incremented, and likewise data is read from the location pointed to by the tail and the tail pointer is incremented. When the head pointer wraps around and reaches the tail pointer, then the buffer is considered full and acquisition stops with a buffer overflow condition. To prevent unintentional incrementing of the tail pointer, the pointer should be incremented after the application has finished reading the data in the buffer and has indicated that the buffer space is relinquished for the write operation.

The Circular Buffer mode is useful in applications that must acquire data with no sample loss. Each acquired sample must be stored by the hardware/driver and read by the application. The data-acquisition operation continues until the application issues a stop command to the driver. If the application cannot keep up with the acquisition process and the buffer overflows, then the acquisition is stopped and the error condition is reported.

Recycled Circular Buffer

The Recycled Circular Buffer mode is similar to the Circular Buffer mode except that when the head pointer catches up with the tail pointer, the tail pointer is automatically incremented to the next frame boundary. This buffer-space recycling occurs irrespective of whether the application read the data or not. In this mode, a buffer overflow condition never occurs.

The Recycled Circular Buffer is best suited for applications that monitor acquired signals at periodic intervals. The application may require the signals to be acquired at a high rate, but not all acquired samples need to be processed. Also, an application may only need the latest block of samples acquired. As the buffer fills up, the driver is free to recycle frames, automatically incrementing the buffer tail, and using the space to store new samples.

While the Advanced Circular Buffer may appear a much different buffering mechanism when compared to the much simpler single and double buffer mechanisms, it is actually a superset of the simpler buffers. The ACB configured in the single buffer mode will behave just as the simple ordinary single buffer. If the ACB is configured as Circular Buffer with two frames, it will behave as a double buffer. With multiple frames, the ACB can be used in algorithms that were designed for buffer queues. The only limitation, which consequently results in more efficient performance, is that the logical buffers in the buffer queues cannot be dynamically allocated and freed. In addition, their order is fixed.

Glossary

A

- ACB** see Advanced Circular Buffer
- A/D (see ADC)** Analog/digital, often used in connection with an A/D converter.
- adapter** Alternate designation for a function card that plugs into a backplane, often a PC.
- ADC (also see A/D)** Analog-to-Digital Converter. An integrated circuit that converts an analog voltage to a digital number.
- ADC conversion** The process of converting an analog input to its digital equivalent.
- ADC conversion Start** Signal used to start the process of converting an analog input to a digital value. The source of this signal can be an internal clock or an external asynchronous signal.
- ADC Channel List Start** Signal used to start the acquisition of digitized values as defined in the Channel List. The triggering edge of this signal (falling edge) enables the ADC conversion Start signals.
- Advanced Circular Buffer** A special user-defined buffer in host memory that stores frames of collected data. The PowerDAQ driver allows the user application to fetch data from this buffer in several modes.
- alias** A false lower-frequency component that appears in sampled data that has been acquired at an insufficiently high sampling rate.
- analog trigger** A trigger that occurs when an analog signal reaches a user-selected level. Users can configure triggering to occur at a specific level on either an increasing or a decreasing signal (positive or negative slope).

- API** Application Programming Interface, a collection of high-level language function calls that provide access to the functions in a driver or other utility.
- asynchronous** (1) Hardware—A property of an event that occurs at an arbitrary time, without synchronization to a reference clock.
(2) Software—A property of a function that begins an operation and returns prior to the completion or termination of the operation.

B

- background acquisition** Data is acquired by a DAQ system while another program or processing routine is running without apparent interruption.
- base address** A memory address that serves as the starting address for programmable registers. All other addresses are located by adding to the base address.
- bipolar** A signal range that includes both positive and negative values (for example, -5V to +5V, also represented as $\pm 5V$).
- bit** One binary digit, either 0 or 1.
- Block mode** A high-speed data transfer in which the address of the data is sent followed by a specified number of back-to-back data words.
- Burst mode** A high-speed data transfer in which the address of the data is sent followed by back-to-back data words while a physical signal is asserted.
- bus** The group of conductors that interconnect individual circuitry in a computer. Typically, a bus is the expansion vehicle to which I/O or other devices are connected. Examples of PC buses are the PCI bus and the PXI bus.
- bus master** A type of plug-in board or controller that can read and write to devices on the computer bus without the assistance of the host CPU.
- byte** Eight related bits of data, an 8-bit binary number. Also used to denote the amount of memory required to store one byte of data.

C

| | |
|-----------------------------------|--|
| cache | High-speed processor memory that buffers commonly used instructions or data to increase processing throughput. |
| calibration | The setting or correcting of a measuring device or base level, usually by adjusting it to match or conform to a dependably known and unvarying measure. |
| channel list | For AO Series boards, a set of entries, one for every channel that should be updated. When the simultaneous-update feature is enabled, all channels are usually updated upon a write to the first or last channel in the channel list. |
| Channel List FIFO | The on-board memory that holds the Channel List. |
| CL clock | The Channel List clock, also known as the Burst clock, tells the control logic how quickly to move to the next entry in the Channel List and set up the front-end operating parameters such as gain. |
| control register | Register containing control bits that set up and configure various onboard subsystems. |
| CMRR | Common-Mode Rejection Ratio, a measure of an instrument's ability to reject interference from a common-mode signal, usually expressed in decibels (dB). |
| code generator | A software program, controlled from an intuitive user interface, that creates syntactically correct high-level source code in languages such as C or Basic. |
| cold-junction compensation | The means to compensate for the ambient temperature in a thermocouple measurement circuit. |
| common-mode range | The input range over which a circuit can handle a common-mode signal. |
| common-mode signal | The mathematical average voltage, relative to the computer's ground, of the signals going into a differential input. |
| component software | An application that contains one or more component objects that can freely interact with other component software. Examples include OLE-enabled applications such as Microsoft Visual Basic and OLE Controls. |
| conversion time | The time, in an analog input or output system, from the moment a channel is interrogated (such as with a |

| | |
|---------------------------------|--|
| | Read instruction) to the moment that accurate data is available. |
| counter/timer | A circuit that counts external pulses or clock pulses (timing), such as the Intel 8254 device. |
| coupling | The manner in which a signal is connected from one location to another. |
| crosstalk | An unwanted signal on one channel due to an input on a different channel. |
| current drive capability | The amount of current a digital or analog output channel can source or sink while still operating within voltage range specifications. |
| current sinking | The ability of a DAQ board to dissipate power from an output signal, either analog or digital. Some sensors apply a voltage to a loop, and the DAQ card must be able to accept the resulting current flow. |
| current sourcing | The ability of a DAQ board to supply current for analog or digital output signals. |
| CV clock | The Conversion Clock, also known as the Pacer clock, it triggers individual acquisitions and thus tells the A/D how fast to digitize successive samples. |

D

| | |
|-----------------------------|--|
| D/A | Digital-to-analog, digital/analog |
| DAC | Digital-to-Analog Converter, an integrated circuit that converts a digital value into a corresponding analog voltage or current. |
| DAC conversion Start | Signal used to start the process of converting a digital value to an analog output. The source of this signal can be either an internal synchronous clock or an external asynchronous signal. |
| DAQ | Data Acquisition (1) Collecting and measuring electrical signals from sensors, transducers, and test probes or fixtures, and moving them to a computer for processing; (2) Collecting and measuring the same kinds of electrical signals with A/D or DIO boards plugged into |

| | |
|---------------------------|---|
| | a PC, and possibly generating control signals with D/A or DIO boards in the same PC. |
| dB | Decibel, the unit for expressing a logarithmic measure of the ratio of two signal levels: $\text{dB} = 20\log_{10}(V1/V2)$ for signals in volts. |
| differential input | An analog-input configuration that measures the difference between signals on two terminals, both of which are isolated from computer ground. |
| DIO | Digital input/output. |
| DLL | Dynamic Link Library, a software module in Microsoft Windows containing executable code and data that can be called or used by Windows applications or other DLLs. Functions and data in a DLL are loaded and linked at run time when they are referenced by a Windows application or other DLLs. |
| DNL | Differential nonlinearity, a measure in LSBs of the worst-case deviation of code widths from their ideal value of 1 LSB. |
| DMA | Direct Memory Access, a method of transferring data to/from computer memory from/to a device or memory on the bus, taking place while the host processor does something else. DMA is the fastest method of transferring data to/from computer memory. |
| drivers | Software that controls a specific hardware device such as a DAQ board. |
| DSP | Digital signal processing. |
| dual-access memory | Memory that can be sequentially accessed by more than one controller or processor but not simultaneously. Also known as shared memory. |
| dual-port memory | Memory that can be simultaneously accessed by more than one controller or processor. |
| dynamic range | The ratio, normally expressed in dB, of the largest signal level in a circuit to the smallest signal level. In DAQ boards it typically refers to the range of signals a board can handle or the amount of noise it suppresses. |

E

| | |
|-------------------------------------|--|
| EEPROM | Electrically Erasable Programmable Read-Only Memory, a nonvolatile memory device you can repeatedly program for storage, erase and reprogram. |
| encoder | A device that converts linear or rotary displacement into digital or pulse signals. The most popular type of encoder is the optical encoder. |
| EPROM | Erasable Programmable Read-Only Memory: A nonvolatile memory device that can be erased (usually by ultraviolet light exposure) and reprogrammed. |
| ESSI | All DSP56300 devices contain two independent and identical Enhanced Synchronous Serial Interfaces, ESSIO and ESSI1. Its maximum frequency is the speed of the DSP core divided by four, and thus on most PowerDAQ cards 16.5 MHz. |
| event | A signal or interrupt generated by a device to notify another device of an asynchronous event. The contents of events are device-dependent. |
| event-based mode | A board operating mode whereby it notifies the user application of certain predefined subsystem events using Win32 calls. It allows you to write asynchronous applications. |
| external trigger | A voltage pulse from an external source that triggers an event such as an A/D conversion. |
| F | |
| FIFO | First-In First-Out, usually used in reference to a memory buffer where the first data stored is the first sent out. |
| Firmware Simultaneous Update | |
| Update | A method for multichannel updates, when every channel holds its value when new data is written and all channels are updated at the same time when data is written to the specific channel/channels. |
| fixed point | A format for processing or storing numbers as digital integers. In fixed-point arithmetic all numbers are represented by integers, fractions (usually restricted between ± 1.0) or a combination of both integers and fractions. Thus integer mathematics can be implemented on all general-purpose processors. |

| | |
|----------------------------------|--|
| floating point | Representing data as a combination of a mantissa and an exponent. The mantissa is usually described by a signed fractional value that has a magnitude ≥ 1.0 and restricted to < 2.0 . The exponent, instead, is an integer and represents the number of places any binary number must be shifted, left or right, in order to yield the desired value. |
| frame | A user-defined number of scans, and these datapoints reside in a predefined portion of a buffer in host-memory. This host-memory buffer is also known as the Advanced Circular Buffer (ACB). |
| function | A set of software instructions executed by a single line of code that may have input and/or output parameters and returns a value when executed. |
| G | |
| gain | The factor by which a signal is amplified, sometimes expressed in dB. |
| gain accuracy | A measure of the deviation of an amplifier's gain from the ideal gain. |
| GUI | Graphical User Interface, an intuitive means of communicating information to and from a computer program by means of graphical screen displays. GUIs can resemble the front panels of instruments or other objects associated with a computer program. |
| H | |
| handler | A device driver installed as part of the computer's OS. |
| hardware | The physical components of a computer system, such as the circuit boards, plug-in boards, chassis, enclosures, peripherals, cables, and so on. |
| Hardware Simultaneous | |
| Update | On AO Series boards, a multichannel update mode whereby when you preprogram the AO logic to update all DACs upon a write to a certain DAC. |
| High Density Family (HDF) | Applies to AO Series boards; models with 96 D/A outputs. |

I

| | |
|----------------------------------|--|
| IMD | Intermodulation Distortion, the ratio, in dB, of the total RMS signal level of harmonic sum and difference distortion products, to the overall RMS signal level. The test signal consists of two sinewaves added together. |
| INL | Integral Nonlinearity, a measure in LSB of the worst-case deviation from the ideal A/D or D/A transfer characteristic of the analog I/O circuitry. |
| input bias current | The current that flows into the inputs of a circuit. |
| input impedance | The measured resistance and impedance between the input terminals of a circuit. |
| input offset current | The difference in the input bias currents of the two inputs of an instrumentation amplifier. |
| instrumentation amplifier | A circuit whose output voltage with respect to ground is proportional to the difference between the voltages at its two inputs. |
| integral control | A control action that eliminates the offset inherent in proportional control. |
| integrating A/D | An A/D whose output code represents the average value of the input voltage over a given time interval. |
| interrupt | A computer signal indicating that the CPU should suspend its current task to service a designated activity. |
| I/O | Input/Output, the transfer of data to/from a computer system involving communications channels, operator interface devices, and/or data-acquisition and control interfaces. |
| IPC | Interprocess Communication, protocol by which processes can pass messages. Messages can be either blocks of data and information packets, or instructions and requests for process(es) to perform actions. A process can send messages to itself, other processes on the same machine, or processes located anywhere on the network. |
| isolation voltage | The voltage that an isolated circuit can normally withstand, usually specified from input to input and/or from any input to the amplifier output, or to the computer bus. |

K

k kilo, the standard metric prefix for 1000 or 10^3 , used with units of measure such as volts, Hertz, and meters.

L

linearity The adherence of device response to the equation $R = KS$, where R = response, S = stimulus, and K is a constant.

LSB Least-significant bit.

M

M mega, the standard metric prefix for 1 million or 10^6 , when used with units of measure such as volts and Hertz; the prefix for 1,048,576, or 2^{20} , when used to quantify data or computer memory.

Mbytes/s A unit for data transfer that means 1 million or 10^6 bytes/sec.

MMI Man-machine interface, the means by which an operator interacts with an industrial automation system; often called a GUI.

multiplexer A switching device with multiple inputs that sequentially connects each of its inputs to its output, typically at high speeds, in order to measure several signals with a single analog input channel.

multitasking A property of an operating system in which several processes can run simultaneously.

mux see multiplexer

N

noise An undesirable electrical signal. Noise comes from external sources such as the AC power line, motors, generators, transformers, fluorescent lights, soldering irons, CRT displays, computers, electrical storms, welders, radio transmitters

as well as internal sources such as semiconductors, resistors and capacitors.

O

OLE

Object Linking and Embedding, a set of system services that provides a means for applications to interact and interoperate. Based on the underlying Component Object Model, OLE is object-enabling system software. Through OLE Automation, an application can dynamically identify and use the services of other applications. OLE also makes it possible to create compound documents consisting of multiple sources of information from different applications.

OLE controls

see ActiveX controls.

operating system

Base-level software that controls a computer, runs programs, interacts with users, and communicates with installed hardware or peripheral devices.

optical isolation

The technique of using an optoelectronic transmitter and receiver to transfer data without electrical continuity to eliminate high potential differences and transients.

OS

see operating system

output settling time

The amount of time required for the analog output voltage of an amplifier to reach its final value within specified limits.

output slew rate

The rate of change of an analog output voltage from one level to another.

overhead

The amount of computer processing resources, such as time or memory, required to accomplish a task.

P

paging

A technique used for extending the address range of a device to point into a larger address space

PCI

Peripheral Component Interconnect, an expansion bus architecture originally developed by Intel to replace ISA and EISA. It offers a theoretical maximum transfer rate of 132M bytes/sec.

PDXI

PowerDAQ eXtensions for Instrumentation, UEI's implementation of the PXI bus standard.

| | |
|------------------------------------|--|
| PGA | see Programmable-gain amplifier |
| PID control | A 3-term control algorithm combining proportional, integral and derivative control actions. |
| pipeline | A high-performance processor structure in which the completion of an instruction is broken into its elements so that several elements can be processed simultaneously from different instructions. |
| PLC | Programmable logic controller, a special-purpose computer used in industrial monitoring and control applications. PLCs typically have proprietary programming and networking protocols and special-purpose digital and analog I/O ports. |
| Polled mode | DAQ board operating mode whereby the user application queries the board about the status of various subsystems as needed. |
| port | A communications connection on a computer or a remote controller. |
| postriggering | The technique used on a DAQ board to acquire a programmed number of samples after trigger conditions are met. |
| potentiometer | An electrical device whose resistance you can manually adjusted; known among engineers as a "pot." |
| pretriggering | The technique used on a DAQ board to keep a continuous buffer filled with data, so that when the trigger conditions are met, the sample includes the data leading up to the trigger condition. |
| programmable-gain amplifier | also see PGA, an amplifier where you can change the amount of gain applied to the inputs. Gain settings today are usually made with software instead of setting jumpers as was necessary with first-generation DAQ boards. |
| programmed I/O | The standard method a CPU uses to access an I/O device—each byte of data is read or written by the CPU. |
| propagation delay | The amount of time required for a signal to pass through a circuit. |
| proportional control | A control action whose output is proportional to the deviation of the controlled variable from a desired setpoint. |

| | |
|---------------------------|---|
| protocol | The exact sequence of bits, characters and control codes used to transfer data between computers and peripherals through a communications channel. |
| pseudodifferential | An analog-input configuration where all channels refer their inputs to a common ground—but this ground is not connected to the computer ground. |
| PXI | PCI eXtensions for Instrumentation, a bus standard that combines the mechanical form factor of the CompactPCI specification and the electrical aspects of the PCI bus. It also adds integrated timing and triggering designed specifically for measurement and automation applications. |
| Q | |
| quantization error | The inherent uncertainty in digitizing an analog value due to the finite resolution of the conversion process. |
| R | |
| real time | A system in which the desired action takes place immediately when all input conditions are fulfilled; it never has to wait for other processes to complete before it can start. In DAQ terms, it generally refers to the processing of data as it is acquired instead of being accumulated and getting processed at a later time. |
| relative accuracy | A measure in LSB of the accuracy of an A/D. It includes all nonlinearity and quantization errors. It does not include offset and gain errors of the circuitry feeding the ADC. |
| resolution | The smallest signal increment that a measurement system can detect. Resolution can be expressed in bits, in proportions, or in percent of full scale. For example, a system has a resolution equal to 12 bits = one part in 4,096 = 0.0244% of full scale. |
| resource locking | A technique whereby a device is signaled not to use one of its resources, often local memory, while that resource is being used by another device, generally the system bus. |
| ribbon cable | A flat cable in which conductors are placed side by side. |

| | |
|-------------------------------|---|
| RMS | Root-mean square, computed by squaring the instantaneous voltage, integrating over the desired time and taking the square root. |
| RTD | Resistance temperature detectors operate based on the principle that electrical resistance varies with temperature. They generally use pure metal elements, platinum being the most widely specified RTD element type although nickel, copper, and Balco (nickel-iron) alloys are also used. Platinum is popular due to its wide temperature range, accuracy, stability as well as the degree of standardization among manufacturers. RTDs are characterized by a linear positive change in resistance with respect to temperature. They exhibit the most linear signal over temperature of any electronic sensing device |
| RTSI | Real Time Systems Integration bus, developed by National Instruments, this intercard bus allows you to transfer data and control signals without using the backplane bus. |
| S | |
| sample | 16-bit binary data that should be converted to the voltage |
| samples/sec | expresses the rate at which a DAQ board digitizes an analog signal. |
| scan | one run through the presently configured Channel List |
| SDK | Software developer's kit, a collection of drivers and utilities that allow engineers to write their own application programs. |
| SE | see single-ended. |
| self-calibrating | reference to a DAQ board that calibrates its own A/D and D/A circuits with a reference source, sometimes provided internally with a precision D/A converter. |
| sensor | A device that generates an electrical signal in response to a physical stimulus (such as heat, light, sound, pressure, motion or flow). |
| Sequential Update mode | Performs multi channel updates where every write to the analog-output channel immediately leads to a change in the output voltage. |

| | |
|---------------------------------|---|
| S/H | Sample/Hold, a circuit that acquires and stores an analog voltage on a capacitor for a short period of time. |
| simultaneous sampling | the act of digitizing multiple channels simultaneously, with interchannel skew often being measured in psec. |
| Simultaneous update mode | On AO Series boards, this mode (also referred to as Update All) all channels previously written to in the Write&Hold mode update their outputs at the same time. |
| single-ended | a term used to describe an analog-input configuration where you measure each channel with respect to a common analog ground. |
| Single-Point Update mode | In an AO Series board, performs an independent update of any available DACs. |
| Slow Bit | a control bit in the analog-input configuration word that instructs the A/D to wait a short while before actually digitizing the input voltage; it gives the input amplifier time to settle, and is very useful when working with very high gains. |
| SNR | also S/N ratio or Signal/Noise ratio, the ratio of the peak power level to the remaining noise power, expressed in dB. |
| software trigger | A programmed event that triggers an event such as a data acquisition. |
| SPDT | Single-pole double-throw, a switch in which one terminal can be connected to one of two other terminals. |
| SSH | Simultaneous Sample/Hold, see simultaneous sampling |
| S/s, S/sec | see samples/sec |
| strain gage | A sensor that converts mechanical motion into an electronic signal. A change in capacitance, inductance or resistance is proportional to the strain experienced by the sensor, but resistance is the most widely used characteristic that varies in proportion to strain. |
| Standard Density Family | |
| (SDF) | Applies to AO Series boards; all models with from 8 to 32 D/A outputs. |

| | |
|---------------------------------|---|
| subroutine | A set of software instructions executed by a single line of code that may have input and/or output parameters. |
| subsystem | On PowerDAQ cards, a group of circuits that perform either analog input, analog output, digital input, digital output or counter/timer functions. |
| successive-approximation | |
| A/D | An A/D that sequentially compares a series of binary-weighted values with an analog input to produce an output digital word in n steps, where n is the A/D's resolution in bits. |
| synchronous | A property of a function that begins an operation and returns only when the operation is complete. |
| system noise | A measure of the amount of noise seen by an analog circuit or an A/D when the analog inputs are grounded. |
| T | |
| TCP/IP | Transmission Control Protocol/Internet Protocol, the basic 2-layer communication protocol of the Internet but that is also used in a private network (either an intranet or an extranet). The higher layer, TCP, manages the assembling of a message or file into smaller packets that are transmitted and received by a TCP layer that reassembles the packets into the original message. IP handles the address portion of each packet so it gets to the right destination. |
| THD | Total harmonic distortion, the ratio of the total RMS signal due to harmonic distortion to the overall RMS signal, expressed in dB or percent. |
| THD+N | The percentage of Total Harmonic Distortion + Noise (THD+N) of a sine wave equals 100 times the ratio of the RMS voltage measured with the fundamental component of a sine wave removed by a notch filter, to the RMS voltage of the fundamental component. |
| thermistor | A temperature-sensing element that exhibits a large change in resistance proportional to a small change in temperature. Thermistors usually have negative temperature coefficients. They tend to be more accurate than thermocouples or RTDs, but they have a much more limited temperature range. |

| | |
|------------------------|--|
| thermocouple | A temperature sensor created by joining two dissimilar metals. The junction produces a small voltage as a function of temperature. |
| throughput rate | The flow of data, measured in bytes/sec, for a given continuous operation. |
| transducer | A device that converts energy from one form to another. Generally applied to devices that convert a physical phenomenon (such as pressure, temperature, humidity or flow) to an electrical signal. |
| transfer rate | The rate, measured in bytes/sec, at which data is moved from a source to a destination after software initialization and setup operations; the maximum rate at which the hardware can operate. |
| Trigger | A signal, in either hardware or software, that initiates or halts a process. In DAQ boards, it generally refers to a signal that starts or stops an A/D, D/A or DIO operation. |

U

| | |
|-------------------|--|
| UCT | User counter/timer |
| unipolar | A signal range that is always positive (for example, 0 to 10 V). |
| Update All | Applicable to AO Series boards; see Simultaneous Update mode |

W

| | |
|----------------------------|---|
| Write&Hold mode | On AO Series boards, a mode whereby data is written to the output register but the output voltage remains unchanged and stays at the previous update value. |
|----------------------------|---|

Z

| | |
|------------------------------|---|
| zero offset | The difference between true zero and an indication given by a measuring instrument. |
| zero-overhead looping | The ability of a high-performance processor to repeat instructions without requiring time to branch to the beginning of the instructions. |

zero-Wait-State memory

Memory fast enough that the processor does not have to wait during any reads and writes to the memory.

Index

A

ACB 59, 119
 Advanced Circular Buffer 119
 Agilent VEE..... 94
 Analog-output subsystem 39
 AO configuration word 66
 API..... 41
 Applications..... 6

B

Base address.....16
 Bootup process
 interrupts 41
 Buffer
 data format..... 65
 structure 49
 Buffered mode..... 43
 configuration flags..... 64
 configuration parameters 64
 Buffered modes 59
 programming model..... 71

C

Cables, master list 104
 CalibrArea array..... 114
 Calibration 54, 113
 Calibration certificate 9
 Channel list..... 49
 configuration..... 67
 data 68
 size 67
 Channel string 49

Clocking 55
 Command format 107
 Control bits 110
 Control Panel applet..... 17
 Counter
 operation..... 86
 set up 86
 Counter/timer
 min/max clock rates 40
 subsystem 40, 85

D

DACs
 quads 57
 DASyLab 94
 Data formats..... 47
 Device drivers 90
 DIADEM 94
 Digital I/O
 configuration..... 82
 edge detection 82
 event handler 83
 polled I/O..... 81
 subsystem 40, 81
 Direct DSP Access mode 43, 52
 Direct DSP Buffer Access mode... 60
 DLLs 41, 46, 90
 DMA 16
 Driver
 structure 46
 DSP 37
 custom programming 37

| | |
|--------------------------------|------------|
| E | |
| Event counting | 85 |
| Event-based mode | 42 |
| Event-Based Waveform mode..... | 43, 52, 59 |
| F | |
| Firmware | 37 |
| Frames..... | 49, 120 |
| G | |
| Glossary..... | 123 |
| H | |
| Hardware | |
| installation | 15 |
| HC models..... | 7 |
| HS models | 7, 39 |
| I | |
| Installation..... | 9 |
| multiple boards..... | 18 |
| Interrupt lines | 41 |
| Interrupts..... | 16 |
| boot process..... | 56 |
| K | |
| Kernel events..... | 41 |
| L | |
| LabVIEW..... | 94 |
| channel list | 43 |
| frames..... | 50 |
| Update channel | 48 |
| VIs | 95 |
| LabVIEW for Linux | 94 |
| LabVIEW Real-Time..... | 94 |
| LabWindows/CVI | 94 |
| Libraries..... | 91 |
| Linux | 11, 92 |
| realtime | 11 |
| RTAI, realtime | 11 |
| RTLinux, realtime..... | 11 |
| Local sensing..... | 29 |
| Logic | |
| programming | 58 |
| M | |
| MATLAB..... | 94 |
| Mode | |
| Asynchronous..... | 44 |
| Buffered..... | 43, 52, 59 |
| Direct DSP Access..... | 43, 52 |
| Direct DSP Buffer Access | 60 |
| DMA | 43 |
| DMA transfer..... | 52 |
| Driver Regenerate..... | 65 |
| Event-Based Waveform..... | 43, 52, 59 |
| Firmware Regenerate | 65 |
| non-DMA..... | 43 |
| Single-Point Update | 43, 51, 58 |
| standard transfer | 52 |
| Synchronous..... | 44 |
| Waveform Regenerate | 43, 52, 60 |
| Model numbers..... | 7 |
| Modes | |
| event-based | 42 |
| polled | 42 |
| transfer | 52 |
| Multiple boards..... | 18 |
| O | |
| OEM header panel | 105 |
| Operating systems | |
| compatibility..... | 9 |
| Output ranges..... | 53 |
| Overvoltage protection..... | 85 |

| | |
|-----------------------------------|------------|
| P | |
| PDXI Configurator | 18 |
| Period | |
| measuring | 85 |
| Polled mode | 42 |
| PowerDAQ Software Suite | 89 |
| Prescaler | 85, 86 |
| Programming | |
| DLLs | 90 |
| general model | 41 |
| include files | 91 |
| language libraries | 91 |
| low-level | 107 |
| modes of operation | 42 |
| OS support | 90 |
| PowerDAQ SDK, structure | 89 |
| PowerDAQ Software Suite | 89 |
| Programming techniques | 44 |
| Pull-up resistors | 81 |
| Pulse-width measurements | 85 |
| Pulse-width modulator | 85 |
| Q | |
| QNX | 13, 93 |
| R | |
| Read commands | 111 |
| Remote sensing | 19, 29 |
| Resets | 54 |
| RTAI | 11 |
| RTLlinux | 11 |
| S | |
| Scans | 49 |
| Screw-terminal panels | 103 |
| PD2 example | 29 |
| PDXI example | 35 |
| Sense lines | 6 |
| local, PCI | 29 |
| local, PDXI | 35 |
| remote | 19 |
| remote, PCI | 29 |
| remote, PDXI | 35 |
| Sequential updates | 52 |
| Set Update All channel command | 111 |
| SimpleTest program | 17 |
| Simultaneous updates | 53, 57 |
| Single-Point Update mode | 43, 51, 58 |
| Software | |
| installation | 10 |
| Linux | 92 |
| QNX | 93 |
| Software Suite | 89 |
| Specifications | 99 |
| <i>StartUpState</i> utility | 54 |
| Subsystem | |
| opening/closing | 45 |
| Synchronization | |
| multiple boards | 18 |
| System requirements | 9 |
| T | |
| TestPoint | 94 |
| Third-party software | 94 |
| Timer | |
| clocking, external | 85 |
| clocking, internal | 85 |
| set up | 86 |
| watchdog | 85 |
| Triggering | 55 |
| U | |
| Update All | |
| command | 111 |
| strobe | 57 |
| Update channel | 69 |
| Update methods | 52 |
| Update rates | 53 |
| aggregate | 5 |

W

Watchdog.....85
Waveform Regenerate mode 43, 52,
60
Windows

versions supported 9
Write commands..... 110

X

xPC Target..... 94

Reader Feedback

We are committed to improving the quality of our documentation, in order to serve you better. Your feedback will help us in the effort. Thanks for taking the time to fill out and return this form.

Is the manual well organized? Yes No

Can you find information easily? Yes No

Were you able to install the PowerDAQ boards? Yes No

Were you able to connect the PowerDAQ board to the accessories? Yes No

Did you find any technical errors? Yes No

Is the manual size appropriate? Yes No

Are the design, type style, and layout attractive? Yes No

Is the quality of illustrations satisfactory? Yes No

How would you rate this manual? Excellent Good Fair Poor

Why? _____

Suggested improvements: _____

Other Comments: _____

Your background (optional): _____

Your application: _____