



ACT20X

User Manual

Revision History

Version	Date	Change
1.0		First Edition

Klingenbergstrasse 16
32758 Detmold
Germany
Phone +49 (0) 5231 14-0
Fax +49 (0) 5231 14-2083
E-Mail info@weidmueller.com
Internet www.weidmueller.com

Contact Address



Weidmüller Interface GmbH & Co. KG
PO Box 3030
32720 Detmold

Contents

Revision History	2
Contact Address	2
Contents	3
1. Approvals.....	5
1.1 CE.....	5
1.2 EMC.....	5
1.3 ATEX.....	5
1.4 IECEX.....	5
1.5 cFMus	5
1.6 UL.....	5
1.7 GOST	5
1.8 DNV	5
2. Warranty Statement	6
2.1 36 Months Warranty	6
3. Safety	7
3.1 Approved Use	7
3.2 Qualified Personnel.....	7
3.3 Accuracy of the Technical Documentation	7
3.4 Liability.....	7
3.5 Definitions.....	7
3.6 Symbol Identification.....	7
3.7 Electrical Precautions.....	8
3.8 General Instructions	8
4. Introduction	9
4.1 Product Description.....	9
4.1.1 Family ACT20X.....	9
4.1.2 General Description	10
4.1.3 The Six Basic Module Types in Detail	10
5. Installation	12
5.1 General	12

5.1.1	Environment.....	12
5.2	Unpacking.....	12
5.3	Mounting.....	13
5.4	Marking.....	13
5.5	Electrical Connections.....	14
5.5.1	EMI Protection.....	14
5.6	Calibration and Adjustment.....	14
5.7	Release Lever.....	14
5.8	Encoding.....	15
5.9	Configuration.....	15
6.	Operation.....	17
6.1	Normal Operation.....	17
6.2	Warm-Up.....	17
6.3	Cleaning.....	17
7.	Product Installation / Operation.....	18
7.1	ACT20X-HDI-SDO (NAMUR Pulse Isolator).....	18
7.1.1	Description.....	18
7.1.2	Status/Alarm LEDs.....	18
7.1.3	Electrical Connections.....	19
7.1.4	Function Description.....	20
7.1.5	Specifications.....	20
7.2	ACT20X-HTI-SAO (Temperature and mA Converter).....	25
7.2.1	Description.....	25
7.2.2	Status/Alarm LEDs.....	25
7.2.3	Electrical Connections.....	26
7.2.4	Specifications.....	27
7.3	ACT20X-SDI-HDO (Solenoid/Alarm Driver).....	35
7.3.1	Description.....	35
7.3.2	Status/Alarm LEDs.....	35
7.3.3	Electrical Connections.....	36
7.3.4	Specifications.....	37
7.4	ACT20X-HUI-SAO (Universal Converter).....	43
7.4.1	Description.....	43
7.4.2	Status/Alarm LEDs.....	43
7.4.3	Electrical Connections.....	44
7.4.4	Specifications.....	45
Appendix.....	54

1. Approvals

1.1 CE

These products fulfill the guidelines issued by the European Union and are therefore entitled to carry the CE mark.

1.2 EMC

In accordance with:

- EN 61326

1.3 ATEX

In accordance with:

- EN 60079-0, -11, -15, -26
- EN 61241-0, -11

ATEX marking:

- II 3 G Ex nA nC IIC T4
- II (1) G [Ex ia] IIC/IIB/IIA
- II (1) D [Ex iaD]



1.4 IECEX

In accordance with:

- IEC 60079-15: 2005
- IEC 60079-11: 2006
- IEC 60079-0: 2007
- IEC 60079-26: 2006
- IEC 61241-0: 2004
- IEC 61241-11: 2005

IECEX marking:

- Ex nA nC IIC T4 Gc
- [Ex ia Ga] IIC/IIB/IIA
- [Ex ia Da] IIIC

1.5 cFMus

In accordance with:

Canada

- E60079-0 - CSA 22.2-157
- E60079-11 - CSA 22.2-213
- E60079-15

USA

- UL60079-0 - FM3600
- UL60079-11 - FM3610
- UL60079-15 - FM3611
- FM3810

cFMus marking:

Install in CL I DIV2 GP A-D T4

Provides IS circuits to CL I-III DIV 1/2 GP A-G or CL I Zn2 AEx/Ex nA nC [ia] IIC T4.



1.6 UL

In accordance with:

- UL 61010-1



1.7 GOST

GOST approval is pending.

1.8 DNV

Marine approval is pending.



2. Warranty Statement

2.1 36 Months Warranty

Weidmüller gives a 36 months warranty on the product in accordance with the warranty terms as described in the general business conditions of the Weidmüller company which has sold the products to you.

Weidmüller guarantees that defects which have already existed at the time when the risk passed will be repaired by Weidmüller free of charge or Weidmüller will provide a new, functionally equivalent product to replace the defective one.

The warranty referred to above covers Weidmüller products. Unless otherwise expressly stated in this catalogue/product description, Weidmüller gives no warranty or guarantee as to the interoperability in specific systems or the fitness for any particular purpose. To the extent permitted by law, any claims for damages and reimbursement of expenses, based on whatever legal reason, including contract or tort, shall be excluded.

Unless otherwise expressly stated in this warranty, the general business conditions and the expressive liability commitments therein of the respective Weidmüller company which has sold the products to you are applicable.

3. Safety

3.1 Approved Use

This product is intended for use in applications as described in the operating instructions only.

Any other utilization is not permitted and can lead to accidents or destruction of the device.

Using the device in non-approved applications will immediately void all guarantee and warranty claims on the part of the operator against the manufacturer.

3.2 Qualified Personnel

These operating instructions are intended for trained and qualified personnel that is familiar with the valid regulations and standards relevant to the field of application.

3.3 Accuracy of the Technical Documentation

These operating instruction were written with due care and attention.

However, unless otherwise required by law, we do not guarantee that the data, images and drawings are accurate or complete nor do we accept liability for their contents.

Weidmüller's general business conditions apply in their respective valid form. They are subject to alteration without notice.

3.4 Liability

To the extent that instructions in this manual are not strictly observed, the customer cannot advance a demand against Weidmüller that would otherwise exist according to the concluded sales agreement.

3.5 Definitions

- Hazardous voltages have been defined as the ranges: 75...1,500 V DC and 50...1,000 V AC.
- Technicians are qualified persons trained to mount, operate and troubleshoot technically correct and in accordance with safety regulations.

- Operators, being familiar with the contents of this manual, adjust and operate the knobs or potentiometers during normal operation.

3.6 Symbol Identification

	DANGER
	Indicates an imminently hazardous situation which, if not avoided, will result in death or serious injury.

	WARNING
	Indicates a potentially hazardous situation which, if not avoided, could result in death or serious injury.

	CAUTION
	Indicates a potentially hazardous situation which, if not avoided, may result in minor or moderate injury.

NOTICE	
Indicates a situation that may result in material damage.	

	The CE mark proves the compliance of the module with the essential requirements of the directives.
---	--

	Ex modules have been approved according to the ATEX directive for use in connection with installations in explosive areas.
---	--

	This symbol is combined with one of the signal words DANGER, WARNING or CAUTION to indicate a hazardous situation.
---	--

	<p>The double insulation symbol shows that the device is protected by double or reinforced insulation..</p>
---	---

3.7 Electrical Precautions

	<p>WARNING</p>
	<p>High voltage!</p> <ul style="list-style-type: none"> • Before removing or mounting the unit, turn off power supply. <p>Follow ESD installation regulations, including EMI precautions.</p>

3.8 General Instructions

- Read and follow all instructions in this manual.
- Inform yourself about hazards which can be caused by the product.
- Observe the safety and accident prevention regulations.
- Regularly check that all measures to prevent accidents are being complied with.
- Only operate the product if it is in perfect technical condition, according to its intended use, in awareness of safety and risks and in adherence to the instructions in this manual.
- Keep this manual and all other applicable documents complete, legible and accessible to personnel at all times.
- Refrain from any procedures and actions that would expose personnel or third parties to any risk.

4. Introduction

4.1 Product Description

4.1.1 Family ACT20X

Order No.	Type	Description	Function
8965340000	ACT20X-HDI-SDO-RNO-S	NAMUR isolator - relay NO	NAMUR in (from Ex) to relay out
8965350000	ACT20X-HDI-SDO-RNC-S	NAMUR isolator - relay NC	NAMUR in (from Ex) to relay out
8965360000	ACT20X-HDI-SDO-S	NAMUR isolator	NAMUR in (from Ex) to digital out
8965370000	ACT20X-2HDI-2SDO-RNO-S	2 Ch. NAMUR isolator - relay NO	2x NAMUR in (from Ex) to 2x relays out
8965380000	ACT20X-2HDI-2SDO-RNC-S	2 Ch. NAMUR isolator - relay NC	2x NAMUR in (from Ex) to 2x relays out
8965390000	ACT20X-2HDI-2SDO-S	2 Ch. NAMUR isolator	2x NAMUR in (from Ex) to 2x digital out
8965400000	ACT20X-SDI-HDO-L-S	Solenoid / alarm driver, L = low current max. 35 mA	digital in to safe digital out (to Ex IIC)
8965410000	ACT20X-SDI-HDO-H-S	Solenoid / alarm driver, H = high current max. 60 mA	digital in to safe digital out (to Ex IIB)
8965420000	ACT20X-2SDI-2HDO-S	2 Ch. Solenoid / alarm driver, low current max. 35 mA	2x digital in to 2x safe digital out (to Ex)
8965430000	ACT20X-HAI-SAO-S	HART-transparent repeater	mA in (from Ex) to mA out with HART transparency
8965440000	ACT20X-2HAI-2SAO-S	2 Ch. HART-transparent repeater	2x mA in (from Ex) to 2x mA out with HART transparency
8965450000	ACT20X-SAI-HAO-S	HART-transparent driver	mA in to mA out (to Ex) with HART transparency
8965460000	ACT20X-2SAI-2HAO-S	2 Ch. HART-transparent driver	2x mA in to 2x mA out (to Ex) with HART transparency
8965470000	ACT20X-HTI-SAO-S	Temperature / mA converter	temperature in (from Ex) to mA out
8965480000	ACT20X-2HTI-2SAO-S	2 Ch. temperature / mA Converter	2x temperature in (from Ex) to 2x mA out
8965490000	ACT20X-HUI-SAO-S	Universal converter	universal analog in (from Ex) to analog (V / mA) + trip relay out

Table 4-1: Family ACT20X

4.1.2 General Description

Weidmüller's ACT20X – new signal converters for hazardous areas: Universal family of products covers the entire field of hazardous area applications with six different basic functions.

With the introduction of its ACT20X modules Weidmüller is offering a completely new family of signal converters for hazardous area applications. With just 11 mm per channel these compactly designed modules require very little space in the electrical cabinet. All ACT20X converters can be configured via a PC utilizing the software 'WI-Manager'. This software is based on vendor-neutral FDT/DTM technology. The innovative modules are designed to be installed in safe or hazardous areas of Zone 2. The ACT20X family includes digital and analogue intrinsically safe converters that both isolate and convert signals from as well as into hazardous areas. The innovative signal converters process 2-wire HART, NAMUR, RTD, thermocouple or DC signals as well as digital signals with electrical connection to hazardous area Zone 0. All modules have 3-way separation and are optionally available with dual channel functionality. With high levels of insulation resistance, accuracy and thermal stability ACT20X modules provide a pure, disturbance free signal at all times. A relay-based error monitoring facility simplifies servicing. ACT20X modules can be utilized in temperatures from -20 °C to $+60\text{ °C}$ without restrictions. They have all relevant international approvals such as ATEX, IECEx, GOST, FM – in other words, the modules are predestined for use in applications all over the world.

Weidmüller specifically developed its ACT20X family of products for process automation tasks in hazardous and non-hazardous area applications. The 16 different variants condition all conventional input signals (2-wire HART, NAMUR, RTD, thermocouple and DC signals) from sources within hazardous area Zone 0 as equally as digital and analogue signals into hazardous areas to control field devices. To ensure rapid error identification the integrated relay output supplies an error message should an error occur – a facility that increases plant availability.

Utilizing the 'WI-Manager' configuration software based on FDT technology (Field Device Tool) makes it possible to adapt all ACT20X products via a PC to meet different process application requirements. For this purpose Weidmüller provides the Device Type Manager (DTM), which can be executed in any FDT-based frame application. As well as fast and error-free parameterization of individual devices DTMs make it possible to evaluate measurement and diagnostic data. In addition, it is possible to unambiguously identify a connected device via DTM.

ACT20X modules are equipped with a cleverly designed connection technology that supports simple, coded mating. The integrated release lever ensures the connection can be disconnected without damage when servicing is required. Devices from the ACT20X family have been designed to operate in an ambient temperature range of -20 °C to $+60\text{ °C}$ – in other words in practically all fields of industry. The hinged and transparent front plate can easily be opened upwards. It has been designed for simple accommodation of device markers.

Products from the ACT20X assortment are designed to be installed in Zone 2 / Div. 2 or in non-hazardous areas; international approvals such as ATEX, IECEx, GOST and FM (Class 1, Division 1 and 2) allow processing of signals from Zone 0 / Div. 1. Put succinctly, the modules are suitable for use in applications across the globe.

4.1.3 The Six Basic Module Types in Detail

NAMUR Isolator

The pulse isolator ACT20X-HDI-SDO is a special signal isolator/converter for NAMUR sensor signals from within Ex Zone 0. Transistor or relay outputs are available on the output side. A dual-channel version is optionally available

Solenoid / Alarm Driver

The digital actuator driver (solenoid valve switch/alarm signaling facility) ACT20X-SDI-HDO is

equipped with an input in the non-hazardous area and an output in Ex Zone 0.

HART-Transparent Repeater

The ACT20X-HAI-SAO signal isolator is a HART-protocol transparent signal isolator for analogue input signals from hazardous area Zone 0 sources. Its output side provides an analogue signal for safe area devices. A dual-channel version is optionally available.

HART-Transparent Driver

The proportional actuator driver ACT20X-SAI-HAO is HART-protocol transparent. The input has been designed for use in non-hazardous areas, the output for Ex Zone 0. A dual-channel version is optionally available.

Thermo/mA Converter

The ACT20X-HTI-SAO temperature signal isolator/converter facilitates utilization of PT 100 sensors. The input circuit is designed for intrinsically safe signals from within Zone 0. Analogue signals are made available on the output side for safe area devices. A dual-channel version is optionally available.

Universal Converter

The universal isolator/converter ACT20X-HUI-SAO is a user configurable temperature and signal converter for PT 100, thermal and current (mA) inputs from within Ex Zone 0 as well as an output for non-hazardous area devices.

Features

- Full functionality interfacing with Zone 0 / Div. 1 hazardous area inputs and outputs
- Approvals include use for Zone 0 (IECEX, ATEX), Class 1, Division 1 and 2 (FM).
- Analogue and binary signal interfacing with measurement and control devices.
- Temperature, D.C., resistance and potentiometer inputs
- Milliamp and relay/opto outputs
- High quality, 3-port isolation
- Dual channel options – minimizes rail space and installation cost

- HART-transparent signaling
- Integral fault alarm
- –20 to +60 °C ambient temperature
- All modules configurable with FDT/DTM Software 'W-Manager'

5. Installation

DANGER	
	<p>Risk of explosion!</p> <ul style="list-style-type: none">• For installation in Zone 2, install the module in an outer enclosure with IP protection of at least IP54.• Protection must be according to type of protection Ex-n or Ex-e.

WARNING	
	<p>High voltage!</p> <ul style="list-style-type: none">• Before removing or mounting the unit, turn off power supply.

NOTICE	
<p>Material damage through ESD!</p> <ul style="list-style-type: none">• Only carry out the following procedures under ESD-safe conditions.	

5.1 General

This product should only be installed by technically qualified personnel with sufficient training in instrumentation and control engineering.

0105 Part 1/DIN EN 50110-1 defines qualified personnel as electrically skilled workers, electronically instructed personnel or personnel meeting similar local standards.

5.1.1 Environment

This product is designed for use either indoors (IP 20) in a control panel, or in a weather-proof field enclosure.

- Avoid direct sunlight, dust, high temperatures, mechanical vibrations and shock as well as rain and heavy moisture.
- If necessary, heating in excess of the stated limits for ambient temperatures should be avoided by ventilation.
- Product must be installed in pollution degree 2 or better.
- Product is designed to be safe at least under an altitude of up to 2,000 m.

5.2 Unpacking

- 1 Check on receipt that the product received corresponds to the one ordered.
- 2 Also make sure that installation instructions have been supplied.
- 3 Unpack the product carefully.

- The use of stranded wires is not permitted for mains wiring except for wires fitted with cable ends.
- Descriptions of input/output and supply connections are shown in the block diagram and on the side label.
- The module is provided with field wiring terminals and must be supplied from a power supply having double/reinforced insulation.
- A power switch must be easily accessible and close to the module.
- The power switch must be marked with a label telling that it will switch off the voltage to the module.
- Year of manufacture can be taken from the first two digits in the serial number.
- Should there be any doubt as to the correct handling of the module, contact your local distributor.

5.3 Mounting

The product is designed to be mounted onto a TS 35 DIN rail.

It clips onto the rail via a spring-loaded mounting foot and can be removed via a spring release on the edge of the product near the mounting rail.

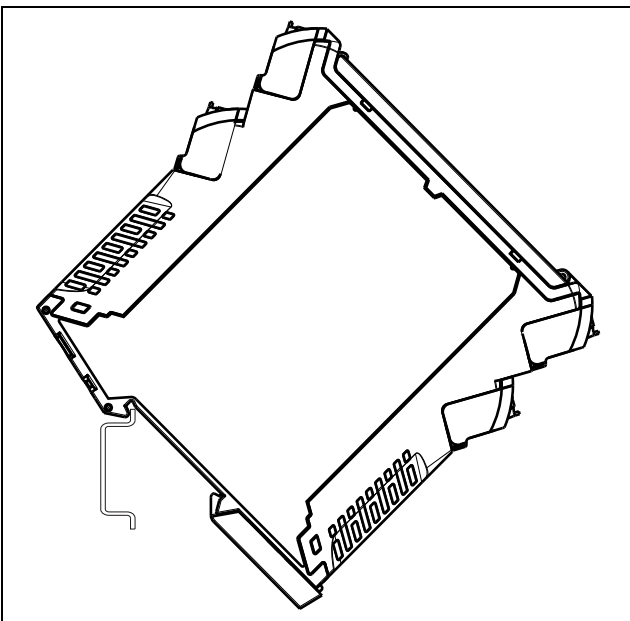

Illustration 5-1: Mounting, Step 1

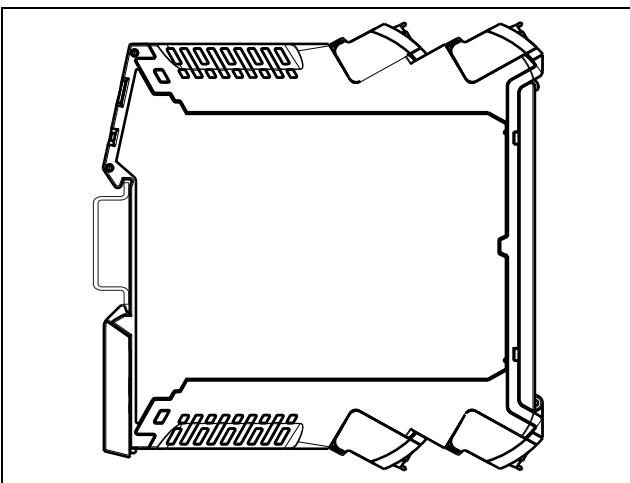

Illustration 5-2: Mounting, Step 2

5.4 Marking

A device marker is located below the upper set of terminals for customer identification.

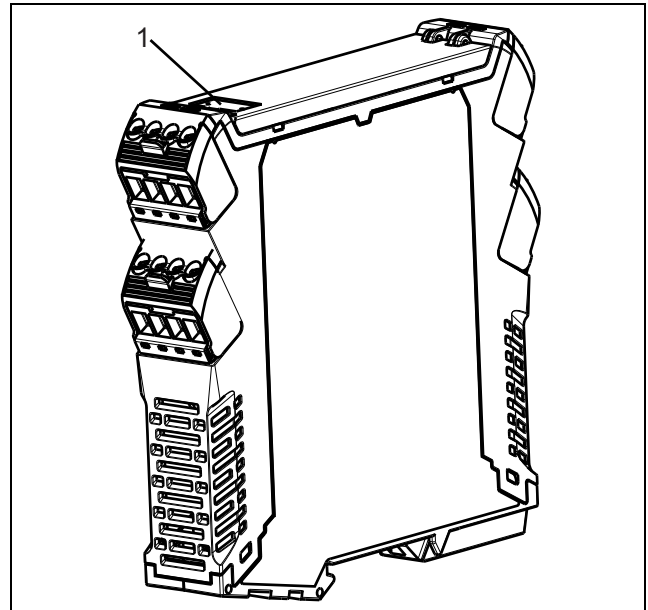

Illustration 5-3: Marking

1 Device Marker

5.5 Electrical Connections

See section 7, "Product Installation / Operation" for further information.

5.5.1 EMI Protection

NOTICE

Do not install input, output and power supply cables close to sources of electrical interference!

For example, sources of electrical interference could include relays, contactors, motors and their controls, including thyristor drives and the cables which connect these devices. Avoid installing ACT20X cables in the same ducting as such cables.

Local electrical installation practices must be followed.

5.6 Calibration and Adjustment

- During calibration and adjustment, carry out the measuring and connection of external voltages according to the specifications in this manual.
- Only use tools and instruments that are safe to use.

5.7 Release Lever

The terminals are released with a release lever.

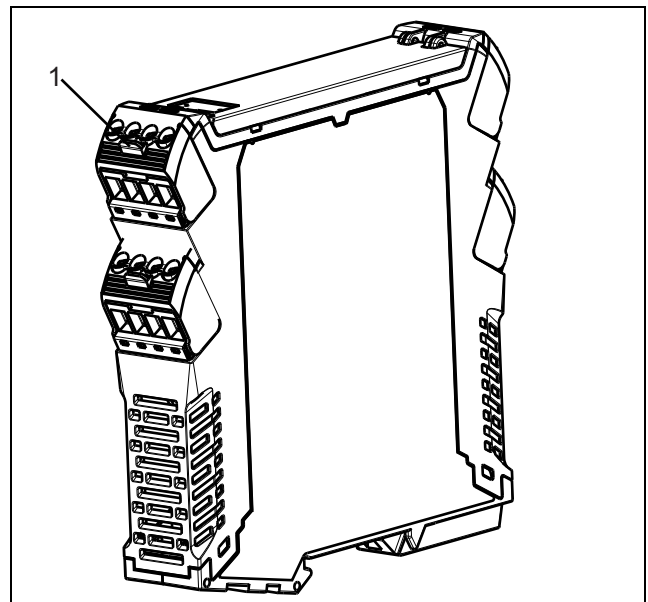

Illustration 5-4: Release Lever

- 1 Release lever

5.8 Encoding

NOTICE

Leaving the product connectors uncoded results in lack of interchanging protection. All connectors will be identically encoded.

- Create connector coding plan prior to first mating and encode connectors accordingly.
- Perform encoding procedure for each new module.

The product housing is equipped with an automatic encoding.

This connector interchanging protection is initially encoded upon shipping and can be individually adjusted.

- 1 Use screw driver to turn adjusting dial of connector clockwise. Either dial has 4 encoding positions, resulting in $4^2 = 16$ possible positions. Connector is encoded.

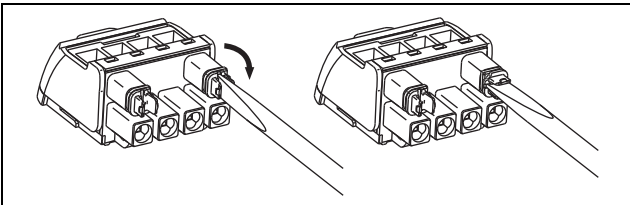

Illustration 5-5: Encoding Connector

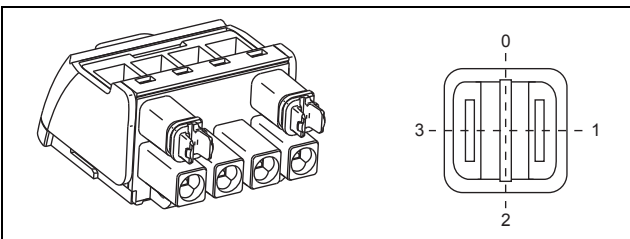

Illustration 5-6: Encoding Positions

- 2 Plug encoded connector onto pin header. Encoding element is transferred from connector to pin header. Encoding element remains in the pin header housing.

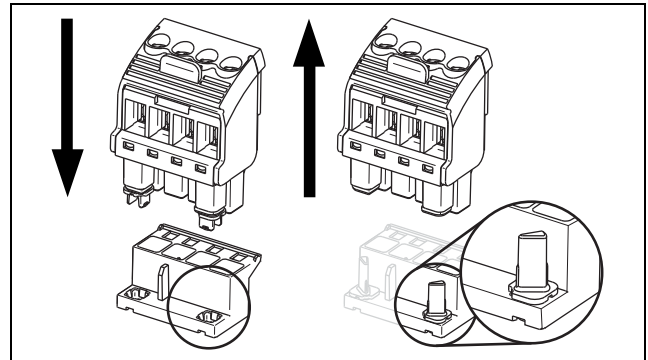

Illustration 5-7: Transfer Encoding Element

5.9 Configuration



DANGER

Configuration must be performed in a safe area!

Configuration is performed via a connector located behind the front flap.

- 1 Open the front flap, as shown in the illustration:

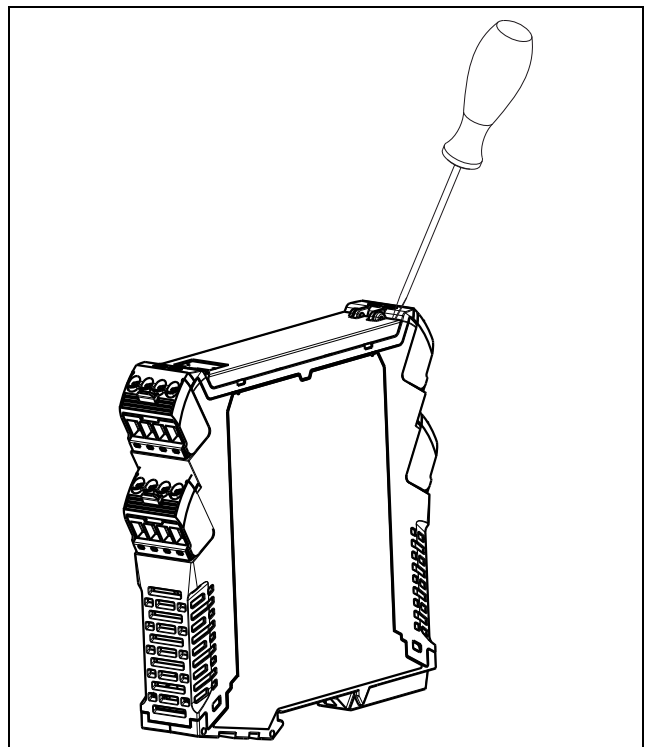

Illustration 5-8: Opening Front Flap

2 Connect the CBX200 USB jack, as shown in the illustration:

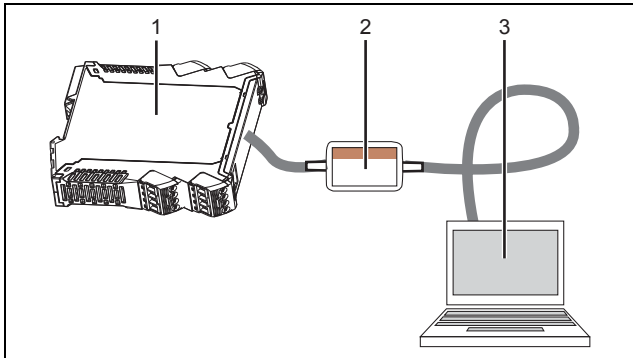

Illustration 5-9: CBX200 USB Connection

- 1 Jack connection under front flap
- 2 CBX200 with USB connection
- 3 PC

3 See *WI-Manager* documentation for further information.

6. Operation

6.1 Normal Operation

Operators are only allowed to adjust and operate modules that are safely fixed in panels, etc., thus avoiding the danger of personal injury and damage. This means there is no electrical shock hazard and the module is easily accessible.

6.2 Warm-Up

The product is designed to start-up as soon as power is supplied. However a warm-up period of 15 minutes is required before it performs to the specifications above.

When auxiliary power is switched on, for the first 200 ms the product will consume up to 200 mA.

6.3 Cleaning

- 1 Power supply switched off.
- 2 Clean with cloth moistened with distilled water.

7. Product Installation / Operation

7.1 ACT20X-HDI-SDO (NAMUR Pulse Isolator)

7.1.1 Description

The NAMUR pulse isolator ACT20X-HDI-SDO is a special signal isolator/converter for NAMUR sensor signals from within Ex Zone 0.

Transistor or relay outputs are available on the output side, a dual-channel version is optionally available.

The following NAMUR pulse isolators are available:

Order No.	Type	Description
8965340000	ACT20X-HDI-SDO-RNO-S	NAMUR isolator - relay NO
8965350000	ACT20X-HDI-SDO-RNC-S	NAMUR isolator - relay NC
8965360000	ACT20X-HDI-SDO-S	NAMUR isolator
8965370000	ACT20X-2HDI-2SDO-RNO-S	2-channel NAMUR isolator - relay NO
8965380000	ACT20X-2HDI-2SDO-RNC-S	2-channel NAMUR isolator - relay NC
8965390000	ACT20X-2HDI-2SDO-S	2-channel NAMUR isolator

7.1.2 Status/Alarm LEDs

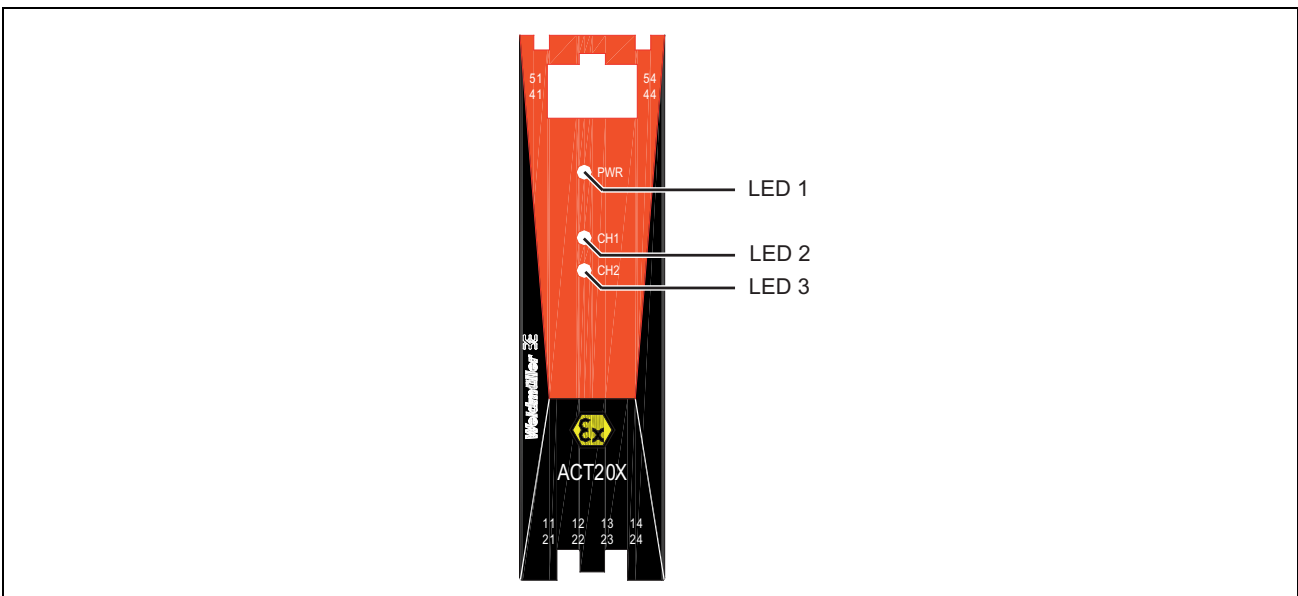

Illustration 7-1: Status/Alarm LEDs

Condition	LED 1	LED 2 (Ch. 1)	LED 3 (Ch. 2)	Status Relay (NC)
No supply	OFF	OFF	OFF	de-energized
Device Failure	OFF	red	red	de-energized
Device OK	green flashing	—	—	energized
Channel 1				
Relay Energized	green flashing	yellow	—	energized
Wire short/break (relay de-energized)	green flashing	red flashing	—	de-energized
Relay De-energized	green flashing	OFF	—	energized
Channel 2				
Relay Energized	green flashing	—	yellow	energized
Wire short/break (relay de-energized)	green flashing	—	red flashing	de-energized
Relay De-energized	green flashing	—	OFF	energized

Table 7-1: Status/Alarm LEDs

7.1.3 Electrical Connections

Terminal	Function	Connector	Terminal	Function	Connector
11	SW Sense	Ex input ch. 1	41	NO/ NC/OPTO-	output ch. 1
12	NAMUR –		42	COM/ /OPTO+	
13	SW Supply		43	NO/ NC/OPTO-	output ch. 2
14	NAMUR +		44	COM/ /OPTO+	
21	SW Sense	Ex input ch. 2	51	GND	supply
22	NAMUR –		52	+24V DC	
23	SW Supply		53	NC.	status
24	NAMUR +		54	COM	

Table 7-2: Electrical Connections

7.1.4 Function Description

- (1) NAMUR sensor cable error detection in case of cable disconnection or short circuit
- (2) Mechanical contact with cable error detection in case of cable disconnection or short circuit, when Rs and Rp are mounted on the contact
- (3) Mechanical contact with cable error detection in case of cable disconnection, when Rs and Rp are mounted on the contact
- (4) Mechanical contact without cable error detection

7.1.5 Specifications

Features

- Pulse isolator for transmission of signals to the safe area from NAMUR sensors and mechanical switches installed in the hazardous area
- Configuration via FDT/DTM Software 'W/Manager'
- Selection of direct or inverted function for each channel
- The module can be mounted in the safe area and in zone 2/div. 2 and receive signals from zone 0, 1, 2, 20, 21 and 22/Class I/II/III, Div. 1, Gr. A-G
- Extended self diagnostic: Monitoring of error events and cable breakage via the individual status relay
- LED indication: green and 2 yellow/red front LEDs to indicate operation status and malfunction
- 3-way galvanic isolation between input, output and supply, 2.6 kV AC

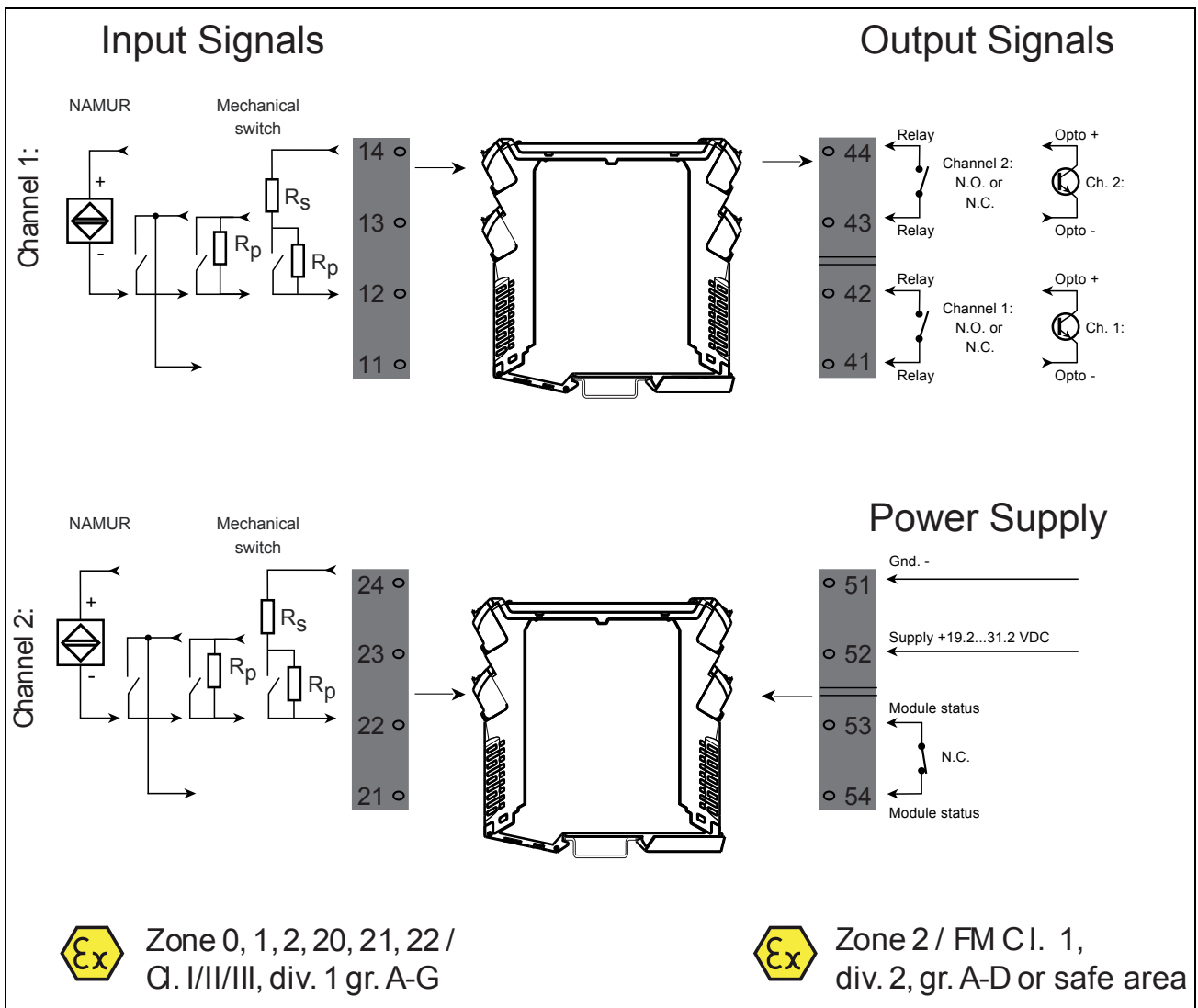

Illustration 7-3: Applications

Inputs

NAMUR sensor	according to EN 60947-5-6
Mechanical switch with serial and parallel resistance:	
Serial resistance	nom. 750 Ω
Parallel resistance	nom. 15 k Ω
Frequency range	0...5 kHz
Min. pulse length	> 0.1 ms
Resistance	nom. 1 k Ω
Trigger level, signal	<1.2 mA, >2.1 mA
Trigger level, cable fault	<0.1 mA, >6.5 mA

Outputs

Relay Output

	Safe Area	Zone 2 Installation
Voltage max.	250 V AC / 30 V	32 V AC / 30 V DC
Power max.	500 VA / 60 W	16 VA / 60 W
Current max.	2 A AC / 2 A DC	2 A AC / 2 A DC

Transistor/NPN Outputs

Max. switch frequency	5 kHz
Min. pulse length	60 μ s
Max. load, current/voltage	80 mA/30 V DC
Voltage drop at 80 mA	< 2.5 V DC

Status Relay Output

	Safe Area	Zone 2 Installation
Voltage max.	125 V AC / 110 V	32 V AC / 32 V DC
Power max.	62.5 VA / 32 W	16 VA / 32 W
Current max.	0.5 A AC / 0.3 A	DC 0.5 A AC / 1 A DC

Common Specifications

Supply voltage	19.2...31.2 V DC
NAMUR supply	8 V DC / 8 mA
Max. consumption	\leq 3 W (2 channels)
Fuse	400 mA / 250 V AC

Isolation Voltages, Test/Operation

Inputs/outputs/supply	2.6 kV AC / 300 V AC reinforced
Output 1 to output 2	1.5 kV AC / 150 V AC reinforced
Status relay to supply	1.5 kV AC / 150 V AC reinforced
Response time for cable fault	< 200 ms

Environmental Specifications

Specifications range	-20...+60 °C
Storage temperature	-20...+85 °C
Relative humidity	<95 % (non-cond.)
Calibration temperature	20...28 °C

General Specifications

Communications interface	configuration software, connection via CBX200
Dimensions (H x W x D)	105.6 x 22.5 x 114.7 mm
Protection degree	IP 20
Screw terminal torque	0.5 Nm
Vibration, IEC 60068-2-6	test Fc, 1g, 2...100 Hz
Vibration, continuous, IEC 60068-2-64	test Fh, 1g, 3...100 Hz
Wire Size	AWG 26...14 / 0.13...2.08 mm ² stranded wire

Default Settings

Ch. 1 Function	direct
Ch. 2 Function	direct
Short Circuit Indication	yes
Breakage Indication	yes

7.2 ACT20X-HTI-SAO (Temperature and mA Converter)

7.2.1 Description

The ACT20X-HTI-SAO is a temperature and mA converter and isolator. It accepts RTD TC and mA signals. The dual-channel version can be used as signal splitter for mA signals.

Following types are available:

Order No.	Type	Description
8965470000	ACT20X-HTI-SAO-S	Temperature/mA converter
8965480000	ACT20X-2HTI-2SAO-S	2 ch. temperature/mA converter
1116064000	ACT20X-CJC-HTI	CJC connector, channel 1
1116065000	ACT20X-CJC-HTI	CJC connector, channel 2

7.2.2 Status/Alarm LEDs

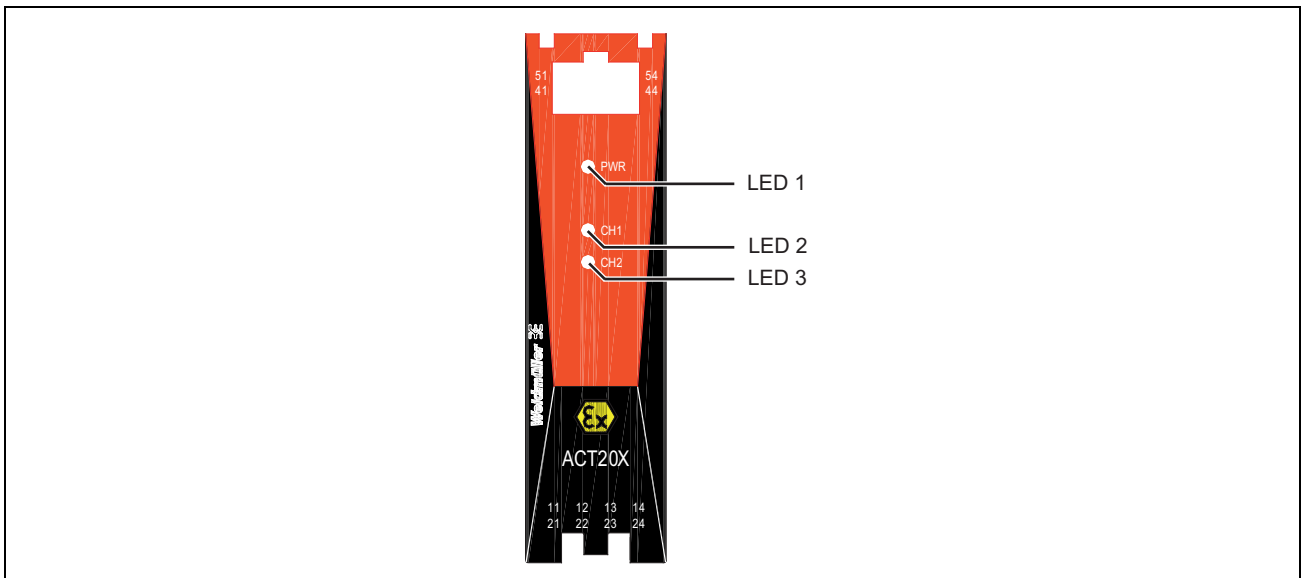

Illustration 7-4: Status/Alarm LEDs

Condition	LED 1	LED 2 (Ch. 1)	LED 3 (Ch. 2)	Status Relay (NC)
No supply	OFF	OFF	OFF	de-energized
Device Failure	green flashing	red	red	de-energized
Device OK	green flashing	—	—	energized
Channel 1				
Relay Energized	green flashing	OFF	—	energized
Wire short/break (relay de-energized)	green flashing	red flashing	—	de-energized
Relay De-energized	green flashing	OFF	—	energized
Channel 2				
Relay Energized	green flashing	—	OFF	energized
Wire short/break (relay de-energized)	green flashing	—	red flashing	de-energized
Relay De-energized	green flashing	—	OFF	energized

Table 7-3: Status/Alarm LEDs

7.2.3 Electrical Connections

Terminal	Function					Connector	Connector	Function	Terminal
	mA	RTD			TC				
		2W	3W	4W					
21			Sense-	Sense-	+	Ex input ch. 2	supply	GND	51
22	-	R	R-	R-	-		+24V	52	
23	+	R	R+	R+			status relay	NC	53
24				Sense+			COM	54	
11			Sense-	Sense-	+	Ex input ch. 1	output ch. 1	Out –	41
12	-	R	R-	R-	-		Out +	42	
13	+	R	R+	R+			output ch. 2	Out –	43
14				Sense+			Out +	44	

Table 7-4: Electrical Connections

7.2.4 Specifications

Features

- Configuration and monitoring are performed via FDT/DTM Software 'WI-Manager' (process calibration, signal simulation).
- Inputs for RTD, TC and mA signals, one or two full separated channels with active or passive inputs.
- TC inputs can use either the internal CJC or a terminal with a built-in Pt100 Sensor ACT20X-CJC-HTI (order No. 116064, channel 1 / order No. 116065, channel 2) for higher accuracy.
- The two-channel version is suitable to use as a signal splitter.
- The device automatically detects whether it is connected to an active or a passive current signal.
- One green and two red front LEDs indicate operation status and malfunction.
- 2.6 kVAC galvanic isolation between input, output and supply
- The device can be mounted in the safe area and in zone 2 / div. 2 and receive signals from zone 0, 1, 2, 20, 21 and 22 / Class I / II / III, Div. 1, Gr. A-G.

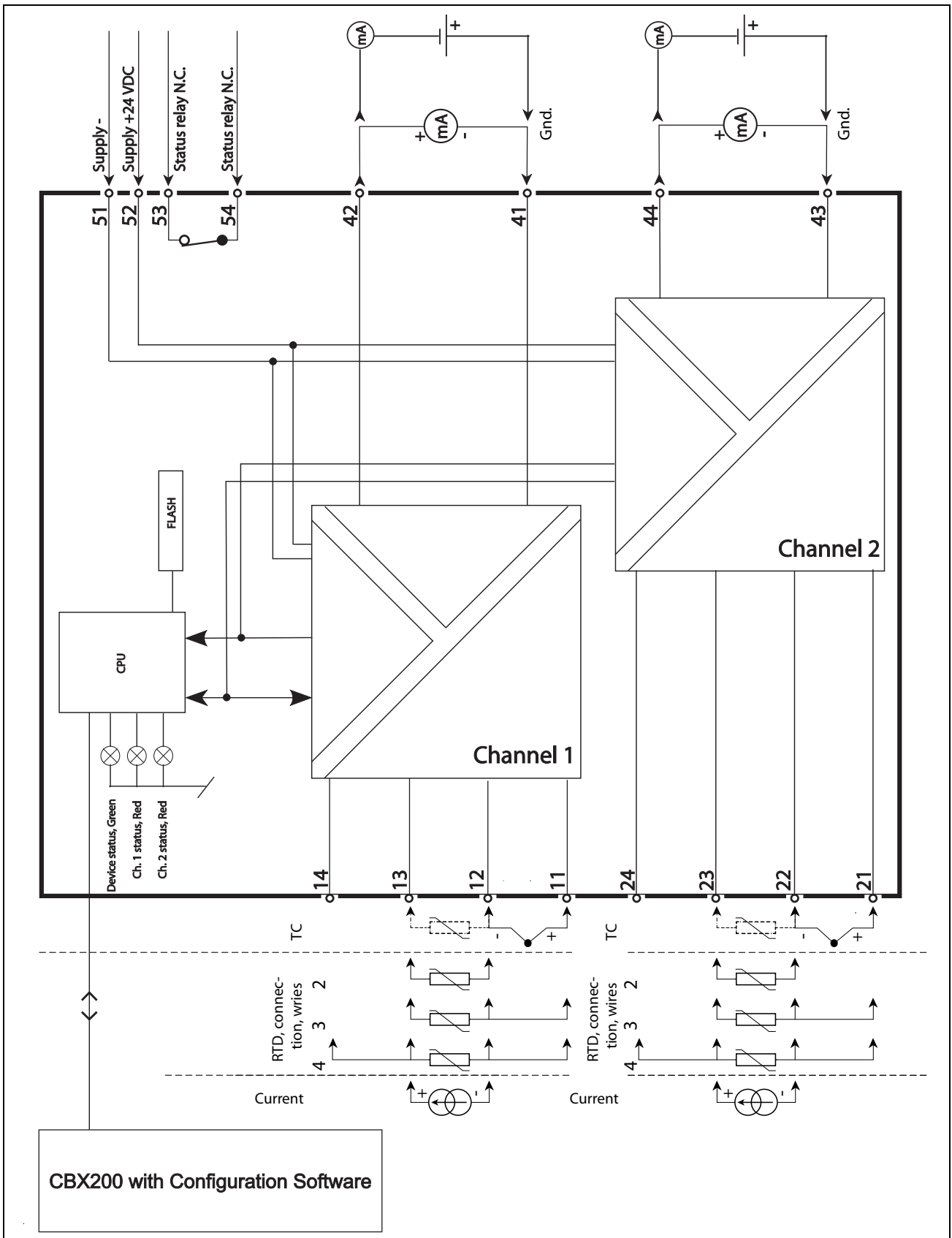

Illustration 7-5: Functional Block Diagram

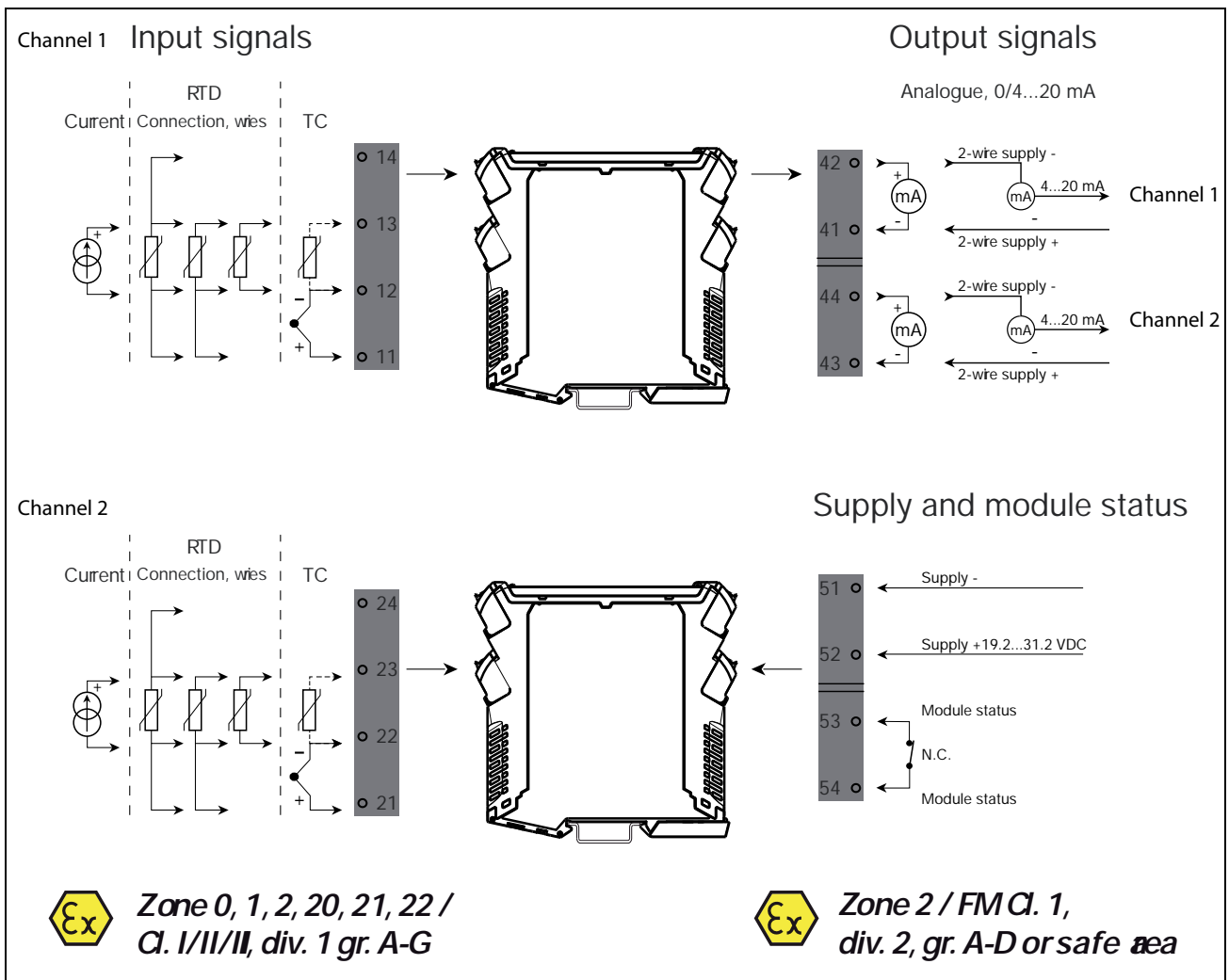

Illustration 7-6: Applications

Specifications

RTD, Input

Input type	Min. value	Max. value	Standard
Pt100	-200 °C	+850 °C	IEC 60751
Ni100	-60 °C	+250 °C	DIN 43760

Input for RTD types	Pt10*, Pt20*, Pt50*, Pt100, Pt250, Pt300, Pt400, Pt500, Pt1000, Ni50, Ni100, Ni120, Ni1000
Cable resistance per wire (max.)	50 Ω
Sensor current	Nom. 0.2 mA
Effect of sensor cable resistance (3-/4-wire)	<0.002 Ω
Sensor error detection	Programmable ON/OFF
Short circuit detection	<2 μA
Else	0 μA

*No short circuit detection for Pt100, Pt200 and Pt50

TC Input

Type	Min. value	Max. value	Standard
B	+0 °C	+1820 °C	IEC 60584-1
E	-100 °C	+1000 °C	IEC 60584-1
J	-100 °C	+1200 °C	IEC 60584-1
K	-180 °C	+1372 °C	IEC 60584-1
L	-200 °C	+900 °C	DIN 43710
N	-180 °C	+1300 °C	IEC 60584-1
R	-50 °C	+1760 °C	IEC 60584
S	-50 °C	+1760 °C	IEC 60584
T	-200 °C	+400 °C	IEC 60584
U	-200 °C	+600 °C	DIN 43710
W3	0 °C	+2300 °C	ASTM E988-90
W5	0 °C	+2300 °C	ASTM E988-90
LR	-200 °C	+800 °C	GOST 3044-84

Cold junction compensation (CJC):

CJC via external sensor in
connector ACT20X CJC 116064 or 116065

20...28 °C $\leq \pm 1$ °C
-20...20 °C and 28...70 °C $\leq \pm 2$ °C

CJC via internal sensor

$\pm(2.0 \text{ °C} + 0.4 \text{ °C} * \Delta t)$

Δt = internal temperature – ambient temperature

Sensor error detection

Programmable ON or OFF (only wire breakage)

Sensor error current:

When detecting

Nom. 2 μ A

Else

0 μ A

Current Input

Measurement range	0...20 mA
Programmable measurement ranges	0...20 and 4...20 mA
Input resistance	Nom. 20 Ω + PTC 50 Ω
Sensor error detection	Programmable ON/OFF only 4...20 mA (NAMUR)

Output

Signal range (span)	0...20 mA
Programmable signal ranges	0...20 / 4...20 / 20...0 and 20...4 mA
Load (max.)	4 mA / 600 Ω / 12 V DC
Load stability	$\leq \pm 0.01$ % of span / 100 Ω
Sensor error detection	0 / 3.5 / 23 mA / none
Output limitation:	
on 4...20 and 20...4 mA signals	3.8...20.5 mA
on 4...20 and 20...4 mA signals	0...20.5 mA
Current limit	≤ 28 mA

2-wire 4...20 mA Output

Signal range	4...20 mA
Load stability	≤ 0.01 % of span / 100 Ω
Load resistance	$\leq (V_{\text{supply}} - 3.5) / 0.023$ A [Ω]
Ext. 2-wire supply range	3.5...26 V DC
Effect of external 2-wire supply voltage variation	< 0.005 % of span / V

Status Relay Output

	Safe Area	Zone 2 Installation
Voltage max.	125 V AC / 110 V	32 V AC / 32 V DC
Power max.	62.5 VA / 32 W	16 VA / 32 W
Current max.	0.5 A AC / 0.3 A	DC 0.5 A AC / 1 A DC

Common Specifications

Supply voltage, DC	19.2...31.2 V DC
Max. consumption	≤ 3.5 W (2 channels)
Fuse	400 mA / 250 V AC
Isolation voltage, test / operation:	
Input / output / supply	2.6 kV AC / 250 V AC
Output 1 to output 2	1.5 kV AC / 150 V AC reinforced
Status relay to supply	1.5 kV AC / 150 V AC reinforced
Communication interface	Programming front 4501

Signal/Noise ratio	Min. 60 dB (0...100 kHz)
Average response time incl. delay:	
Temperature input	≤ 1 s
mA input	≤ 0.4 s
Calibration temperature	20...28 °C

Isolation Voltages, Test/Operation

Inputs/outputs/supply	2.6 kV AC/250 V AC
Output 1 to output 2	1.5 kV AC/150 V AC reinforced
Status relay to supply	150 V AC reinforced
Response time for cable fault	<200 ms

Environmental Specifications

Ambient temperature	-20...+60 °C
Storage temperature	-20...+85 °C
Relative humidity	<95 % (non-cond.)
Calibration temperature	20...28 °C

General Specifications

Communications interface	configuration software, connection via CBX200
Dimensions (H x W x D)	105.6 x 22.5 x 114.7 mm
Protection degree	IP 20
Screw terminal torque	0.5 Nm
Vibration, IEC 60068-2-6	test Fc, 1g, 2...100 Hz
Vibration, continuous, IEC 60068-2-64	test Fh, 1g, 3...100 Hz
Wire Size	AWG 26...14/0.13...2.08 mm ² stranded wire
EMC immunity influence	≤ ±0.5 % of span
Extended EMC immunity:	

Accuracy

General Values

Input Type	Absolute Accuracy	Temperature Coefficient
All	≤ ±0.1 % of span	≤ ±0.01 % of span / °C

Basic Values

Input Type	Absolute Accuracy	Temperature Coefficient
mA	$\leq \pm 16 \mu\text{A}$	$\leq \pm 0.16 \mu\text{A} / ^\circ\text{C}$
Pt100, Pt200, Pt1000	$\leq \pm 0.2 ^\circ\text{C}$	$\leq \pm 0.02 \text{ C} / ^\circ\text{C}$
Pt500, Ni100, Ni120, Ni1000	$\leq \pm 0.3 ^\circ\text{C}$	$\leq \pm 0.03 \text{ C} / ^\circ\text{C}$
Pt50, Pt400, Ni50	$\leq \pm 0.4 ^\circ\text{C}$	$\leq \pm 0.04 \text{ C} / ^\circ\text{C}$
Pt250, Pt300	$\leq \pm 0.6 ^\circ\text{C}$	$\leq \pm 0.06 \text{ C} / ^\circ\text{C}$
Pt20	$\leq \pm 0.8 ^\circ\text{C}$	$\leq \pm 0.08 \text{ C} / ^\circ\text{C}$
Pt10	$\leq \pm 1.4 ^\circ\text{C}$	$\leq \pm 0.14 \text{ C} / ^\circ\text{C}$
TC type: E, J, K, L, N, T, U	$\leq \pm 1 ^\circ\text{C}$	$\leq \pm 0.1 \text{ C} / ^\circ\text{C}$
TC type: R, S, W3, W5, LR	$\leq \pm 2 ^\circ\text{C}$	$\leq \pm 0.2 \text{ C} / ^\circ\text{C}$
TC type: B 160...400 °C	$\leq \pm 4.5 ^\circ\text{C}$	$\leq \pm 0.45 \text{ C} / ^\circ\text{C}$
TC type: B 400...1820 °C	$\leq \pm 2 ^\circ\text{C}$	$\leq \pm 0.2 \text{ C} / ^\circ\text{C}$

Default Settings

Input Type	Temperature
Connection Type	3 wire
Temperature Unit	$^\circ\text{C}$
Temperature Sensor Type	Temperature
PT Type	PT 100

Output Parameters

Output Current Range	4...20 mA
Output Current on Error	23 mA
Analog Output Response Time (1/10 s)	1

Condition	Green LED	Ch. 1: Red LED	Ch. 2: Red LED	Status Relay, N.C.
Device OK	Flashing	OFF	OFF	Energized
No supply	OFF	OFF	OFF	De-energized
Device defective	OFF	ON	ON	De-energized
Ch. 1 defective (ch. 2 OK)	Flashing	ON	OFF	De-energized
Ch. 2 defective (ch. 1 OK)	Flashing	OFF	ON	De-energized
Channel 1, signal OK	Flashing	OFF	OFF	Energized
Ch. 1, wire short / break	Flashing	Flashing	OFF	De-energized
Channel 2, signal OK	Flashing	OFF	OFF	Energized
Ch. 2, wire short / break	Flashing	OFF	Flashing	De-energized

7.3 ACT20X-SDI-HDO (Solenoid/Alarm Driver)

7.3.1 Description

The ACT20X-SDI-HDO is a solenoid/alarm driver for the control of solenoids, acoustic alarms and LEDs mounted in the hazardous area (Ex Zone 0).

The following solenoid/alarm drivers are available:

Order No.	Type	Description
8965400000	ACT20X-SDI-HDO-L-S	solenoid/alarm driver, L = low current max. 35 mA
8965410000	ACT20X-SDI-HDO-H-S	solenoid/alarm driver, H = high current max. 60 mA
8965420000	ACT20X-2SDI-2HDO-S	2-channel solenoid/alarm driver, low current max. 35 mA

7.3.2 Status/Alarm LEDs

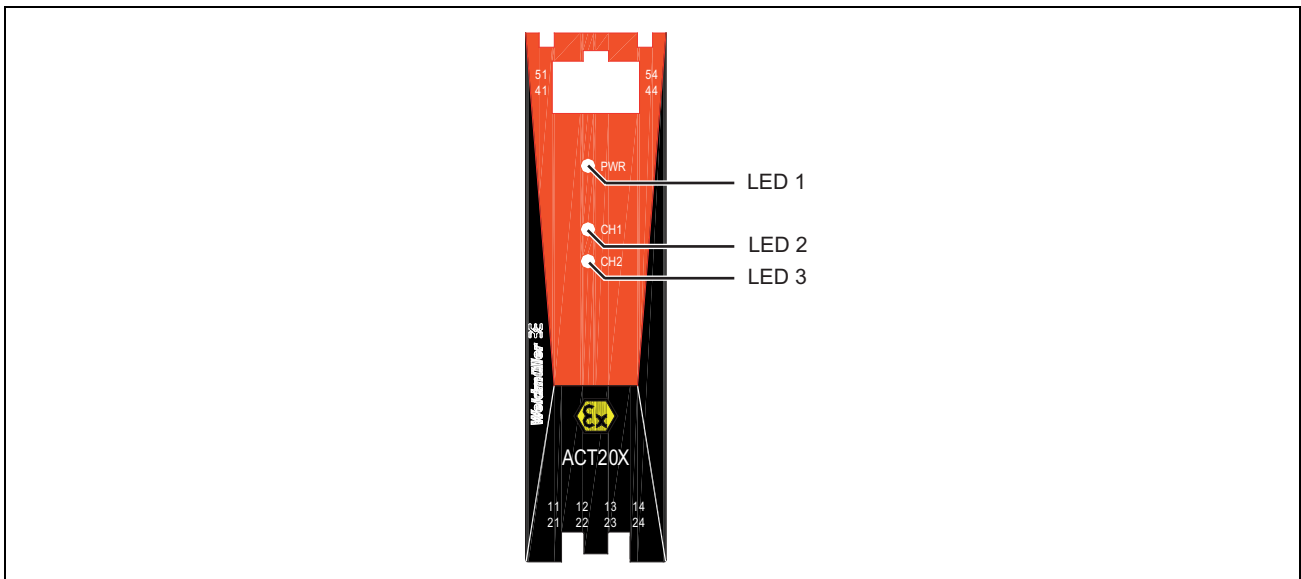

Illustration 7-7: Status/Alarm LEDs

Condition	LED 1	LED 2 (Ch. 1)	LED 3 (Ch. 2)	Status Relay (NC)
No supply	OFF	OFF	OFF	de-energized
Device Failure	OFF	red	red	de-energized
Device OK	green flashing	—	—	energized
Channel 1				
Output On	green flashing	yellow	—	energized
Output Off	green flashing	OFF	—	energized
Channel 2				
Output On	green flashing	—	yellow	energized
Output Off	green flashing	—	OFF	energized

Table 7-5: Status/Alarm LEDs

7.3.3 Electrical Connections

Terminal	Function	Connector	Terminal	Function	Connector
11	GND	Ex output ch. 1	41	In –	input ch. 1
12	Ex 1		42	In +	
13	Ex 2		43	In –	input ch. 2
14	Ex 3		44	In +	
21	GND	Ex output ch. 2	51	GND	supply
22	Ex 1		52	+24V DC	
23	Ex 2		53	NC.	status
24	Ex 3		54	COM	

Table 7-6: Electrical Connections

7.3.4 Specifications

Features

- Solenoid/alarm driver for the control of solenoids, acoustic alarms and LEDs installed in the hazardous area
- Two hardware versions make it possible to choose either low (35 mA) or high (50 mA) current output with 1-channel or 2-channel versions
- Configuration via FDT/DTM Software 'W/Manager'. Selection of direct or inverted function for each channel and the possibility of reducing the output current to the hazardous area to suit the application
- The module can be mounted in the safe area and in zone 2/div. 2 and receive signals from zone 0, 1, 20, 21 and 22/Class I/II/III, Div. 1, Gr. A-G
- Extended self diagnostic: Monitoring of error events via the individual status relay
- LED indication: green and 2 yellow/red front LEDs to indicate operation status and malfunction
- 3-way galvanic isolation between input, output and supply, 2.6 kV AC

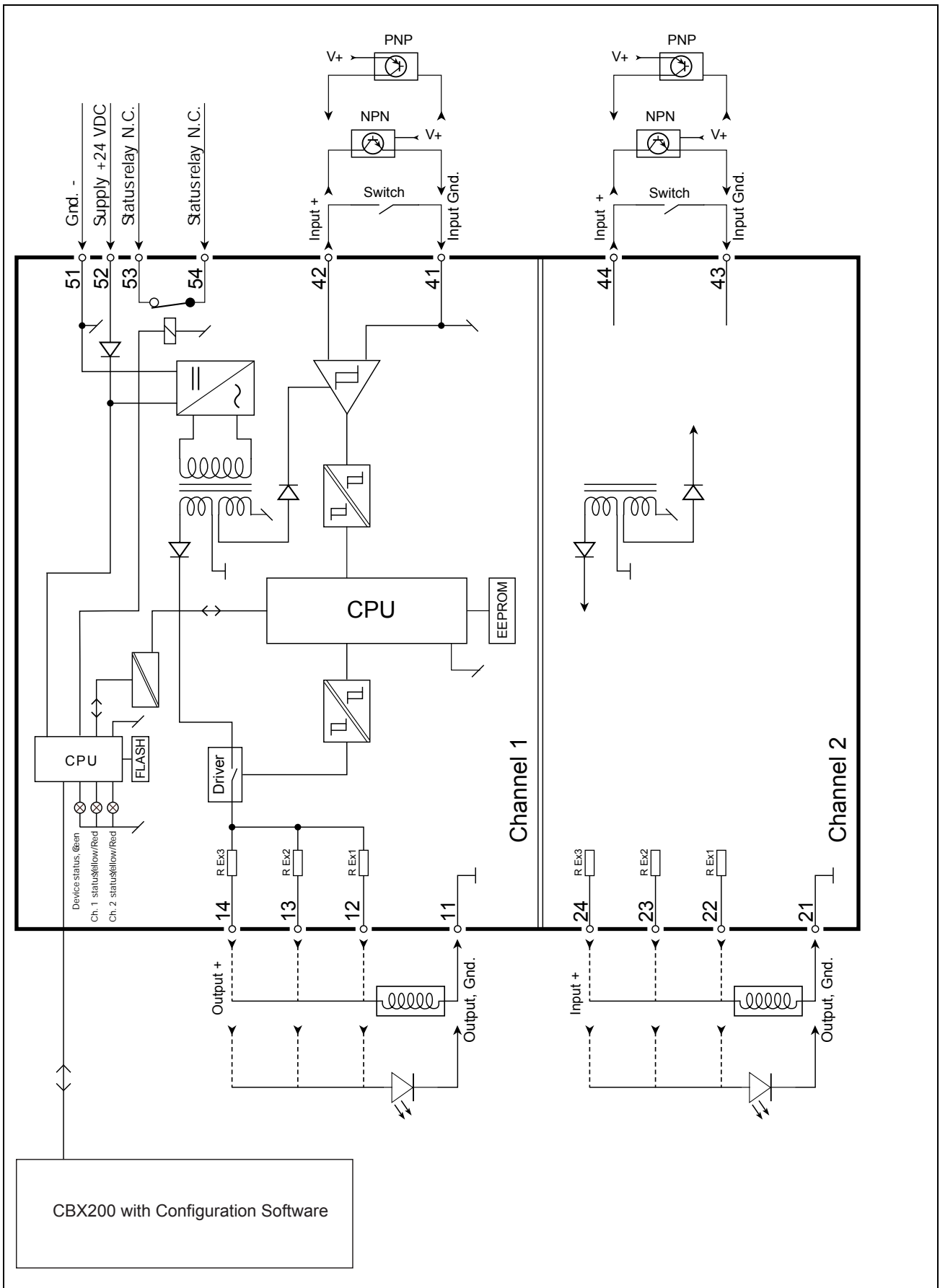

Illustration 7-8: Functional Block Diagram

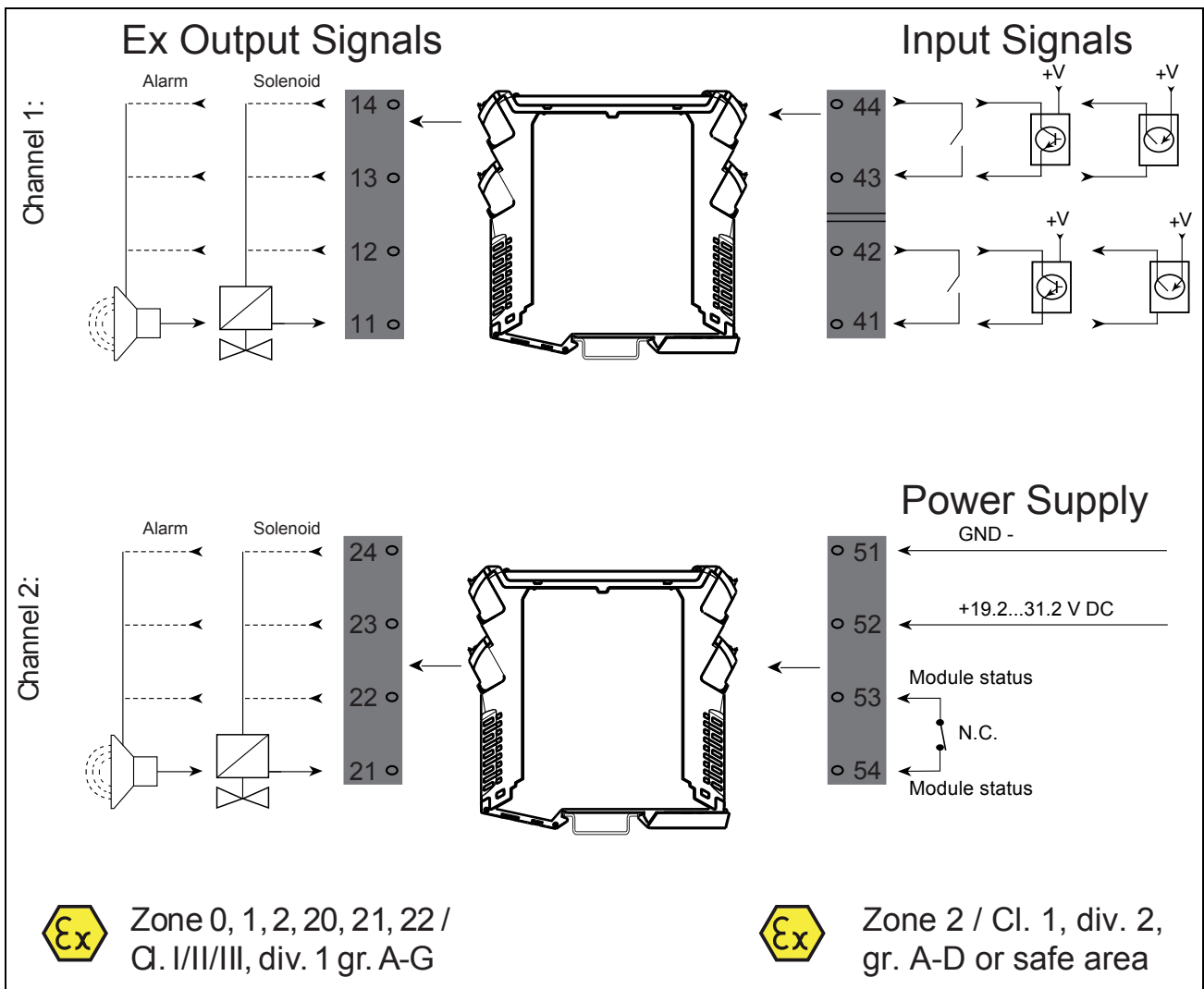

Illustration 7-9: Applications

Inputs

NPN Inputs

NPN and mechanical switch:

Trigger level (low)	≤ 2.0 V DC
Trigger level (high)	≥ 4.0 V DC
Max. external voltage	28 V DC
Input impedance	3.50 kΩ

PNP Inputs

Trigger level (low)	≤ 8.0 V DC
Trigger level (high)	≥ 10.0 V DC
Max. external voltage	28 V DC
Input impedance	3.50 kΩ

Output

Output ripple	< 40 mV RMS
---------------	-------------

Low current (< 35 mA) Ex barrier data channel 1:

Terminal channel 1	V _{out} no load	V _{out} with load	I _{out} max.
11–12	Min. 24 V	Min. 12.5 V	35 mA
11–13	Min. 24 V	Min. 13.5 V	35 mA
11–14	Min. 24 V	Min. 14.5 V	35 mA

Low current (< 35 mA) Ex barrier data channel 2:

Terminal channel 2	V _{out} no load	V _{out} with load	I _{out} max.
21–22	Min. 24 V	Min. 12.5 V	35 mA
21–23	Min. 24 V	Min. 13.5 V	35 mA
21–24	Min. 24 V	Min. 14.5 V	35 mA

High current (< 60 mA) Ex Barrier data only one channel available on 11-14:

Terminal channel 1	V _{out} no load	V _{out} with load	I _{out} max.
11–12	Min. 24 V	Min. 9 V	60 mA
		Min. 11.5 V	50 mA
11–13	Min. 24 V	Min. 10 V	60 mA
		Min. 12.5 V	50 mA
11–14	Min. 24 V	Min. 11 V	60 mA
		Min. 13.5 V	50 mA

896540 (ACT20X-SDI-HDO-L-S), 896542 (ACT20X-2SDI-2HDO-S),
Data channel 1, 11–14

Terminal channel 1	U _m : VAC	U _o : VDC	I _o : mADC	P _o W	L _o mH	C _o nF	V _{out} no load	V _{out} with load	I _{out} max.
11–12	253	28	93	0.65	2.0	80	Min. 24 V	Min. 12.5 V	35 mA
11–13	253	28	100	0.70	2.0	80	Min. 24 V	Min. 13.5 V	35 mA
11–14	253	28	110	0.77	2.0	80	Min. 24 V	Min. 14.5 V	35 mA

896542 (ACT20X-2SDI-2HDO-S),
Data channel 2, 21–24

Terminal channel 2	U _m : VAC	U _o : VDC	I _o : mADC	P _o W	L _o mH	C _o nF	V _{out} no load	V _{out} with load	I _{out} max.
21–22	253	28	93	0.65	2.0	80	Min. 24 V	Min. 12.5 V	35 mA
21–23	253	28	100	0.70	2.0	80	Min. 24 V	Min. 13.5 V	35 mA
21–24	253	28	110	0.77	2.0	80	Min. 24 V	Min. 14.5 V	35 mA

896541 (ACT20X-SDI-HDO-H-S),
Ex barrier data channel 1, 11–14

Terminal channel 1	U _m : VAC	U _o : VDC	I _o : mADC	P _o W		L _o mH	C _o nF	V _{out} no load	V _{out} with load	I _{out} max.
11–12	253	28	115	0.81	IIA	20.8	2100	24 V	11.5 V	50 mA
					IIB	10.8	640		9 V	60 mA
					IIC	2.68	80			
11–13	253	28	125	0.88	IIA	17.6	2100	24 V	12.5 V	50 mA
					IIB	9.1	640		10 V	60 mA
					IIC	–	–			
11–14	253	28	135	0.95	IIA	15.1	2100	24 V	13.5 V	50 mA
					IIB	7.8	640		11 V	60 mA
					IIC	–	–			

Status Relay Output

	Safe area	Zone 2 installation
Voltage max.	125 V AC / 110 V DC	32 V AC / 32 V DC
Current max.	0.5 A AC / 0.3 A DC	0.5 AC / 0.1 A DC
Power max.	62.5 VA / 32 W	16 VA / 32 W

Common Specifications

Supply voltage	19.2...31.2 V DC
Max. consumption	≤ 3.5 W (2 channels)
Fuse	400 mA / 250 V AC
EMC immunity influence	< ± 0.5 % of span
Extended EMC immunity: NAMUR NE 21, A criterion, burst	< ± 1 % of span

Isolation Voltages, Test/Operation

Inputs/outputs/supply	2.6 kV AC / 250 V AC
Output 1 to output 2	1.5 kV AC / 150 V AC reinforced
Status relay to supply	1.5 kV AC / 150 V AC reinforced

Environmental Specifications

Ambient temperature	-20...+60 °C
Storage temperature	-20...+85 °C
Relative humidity	< 95 % (non-cond.)
Calibration temperature	20...28 °C

General Specifications

Communications interface	Configuration software, connection via CBX200
Dimensions (H x W x D)	105.6 x 22.5 x 114.7 mm
Protection degree	IP 20
Screw terminal torque	0.5 Nm
Wire Size (min./max.)	AWG 26...14/0.13...2.08 mm ² stranded wire

Default Settings

Input Parameters

Ch. 1 Function	Direct
Ch. 2 Function	Direct
Short circuit indication	no
Breakage indication	no

7.4 ACT20X-HUI-SAO (Universal Converter)

7.4.1 Description

The universal isolator/converter ACT20X-HUI-SAO is a user configurable temperature and signal converter for PT 100, thermal and current (mA) inputs from within Ex Zone 0 as well as an output for non-hazardous area devices.

Following types are available:

Order No.	Type	Description
8965490000	ACT20X-HUI-SAO-S	Universal converter

7.4.2 Status/Alarm LEDs

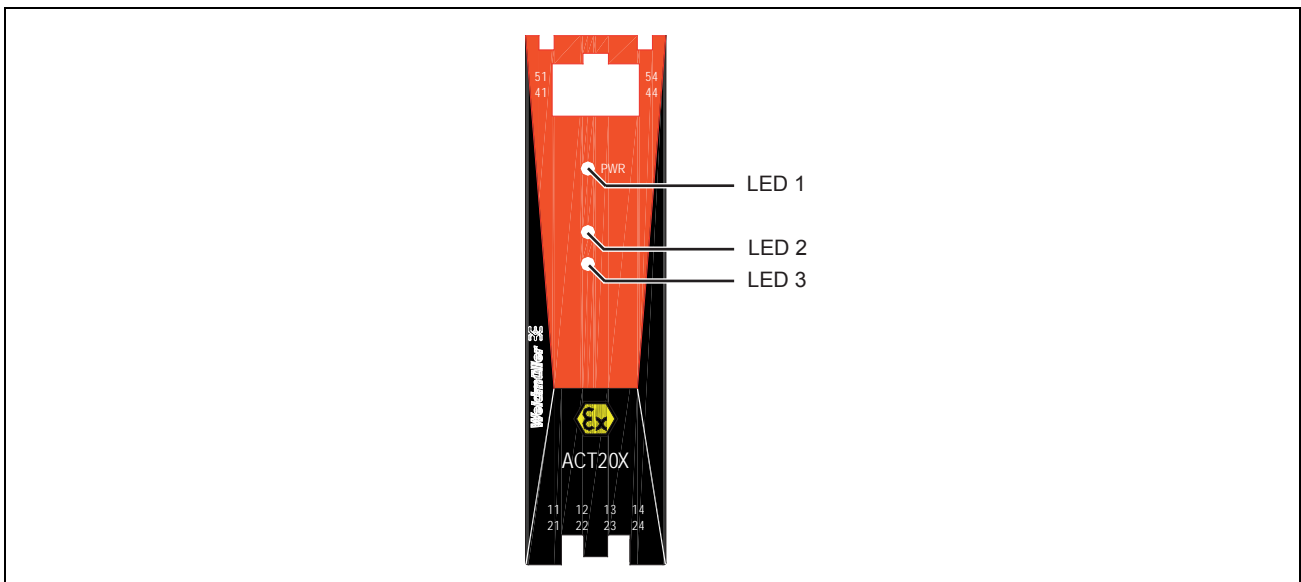

Illustration 7-10: Status/Alarm LEDs

Condition	LED 1	LED 2 (relay)	LED 3 (error)	Status Relay (NC)
No supply	OFF	OFF	OFF	de-energized
Device Failure	OFF	—	red	de-energized
Device OK	green flashing	—	—	energized
Signal OK	green flashing	—	OFF	energized
Output relay Energized	green flashing	yellow	OFF	energized
Output relay energized with wire short/break	green flashing	yellow	red flashing	de-energized
Output relay de-energized with wire short/break	green flashing	OFF	red flashing	de-energized
Output relay de-energized	green flashing	OFF	OFF	energized

Table 7-7: Status/Alarm LEDs

7.4.3 Electrical Connections

Terminal	Function						Terminal	Function	Connector
	TC	RTD	POT	V	mA	Loop			
11	+	3W / 4W					41	Out –	Output
12	-	2W /3W / 4W	M3			3	42	Out +	
13		2W /3W / 4W	M1			1	43	NO	Output relay
14	+	3W / 4W	M2				44	COM	
21	-			-	-		51	GND	Supply
22	-				+	-	52	+24V	
23				+			53	NC.	Status relay
24						+	54	COM	

Table 7-8: Electrical Connections

7.4.4 Specifications

Features

- Configuration and monitoring are performed via FDT/DTM Software 'WI-Manager' (process calibration, signal simulation).
- Inputs for RTD, TC, Ohm, potentiometer, mA and V.
- Power supply and signal isolator for 2-wire transmitters.
- The input of the ACT20X-HUI-SAO can receive active and passive current signals.
- Advanced relay configuration, e.g. setpoint, window, delay, sensor error indication and power monitoring.
- Reduced U_0 Ex data < 8.3 V for active input signals (see Ex data in appendix).
- TC inputs can use either the internal CJC or a terminal with a built-in Pt100 Sensor ACT20X-CJC-HTI (order No. 116064, channel 1 / order No. 116065, channel 2) for higher accuracy.
- The device automatically detects whether it is connected to an active or a passive current signal.
- One green and one red front LEDs indicate operation status and malfunction. One yellow LED indicates the relay status.
- 2.6 kVAC galvanic isolation between input, output and supply
- The device can be mounted in the safe area and in zone 2 / div. 2 and receive signals from zones 0, 1, 2, 20, 21 and 22 / Class I/II/III, Div. 1, Gr. A-G.

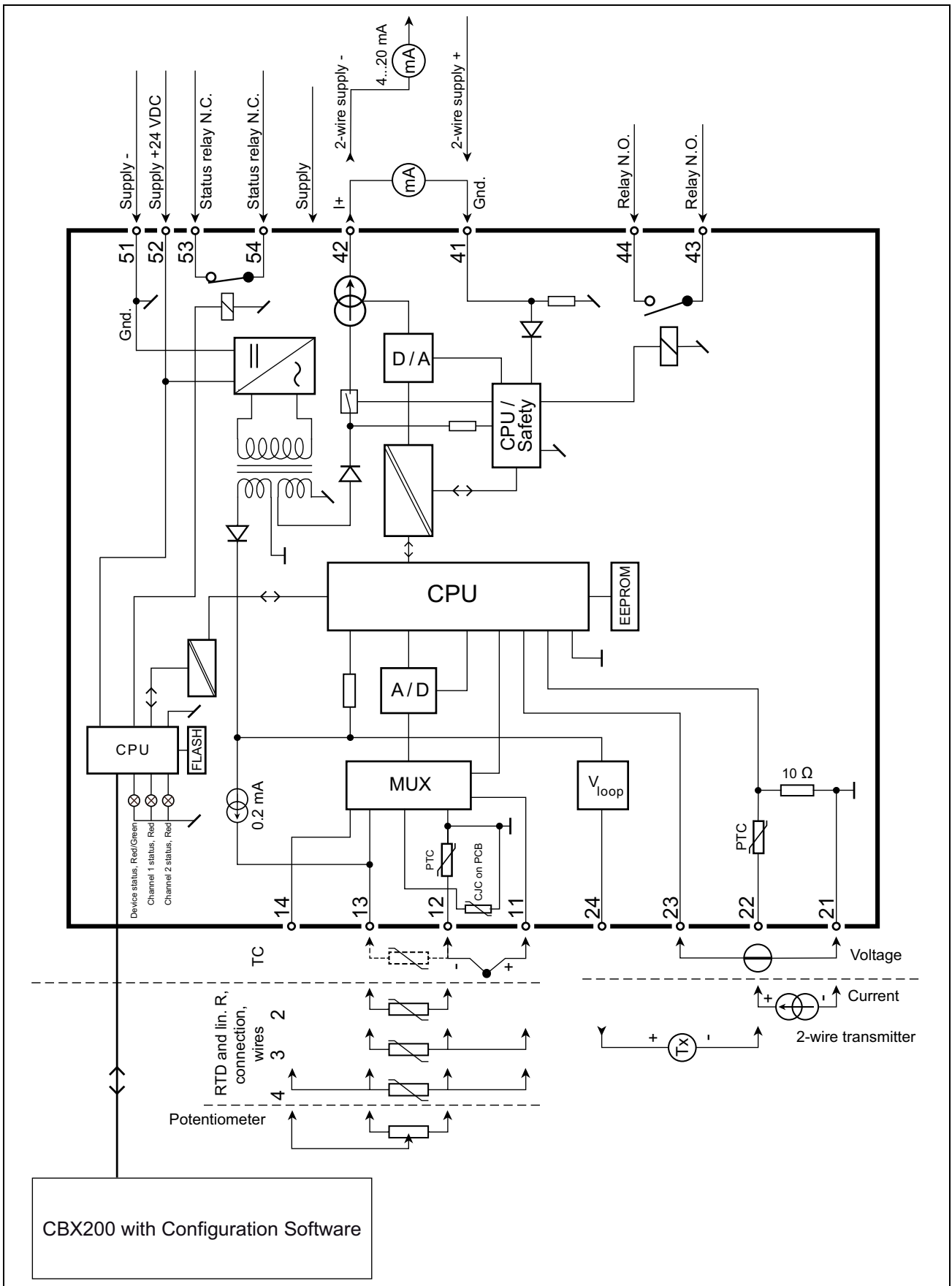

Illustration 7-11: Functional Block Diagram

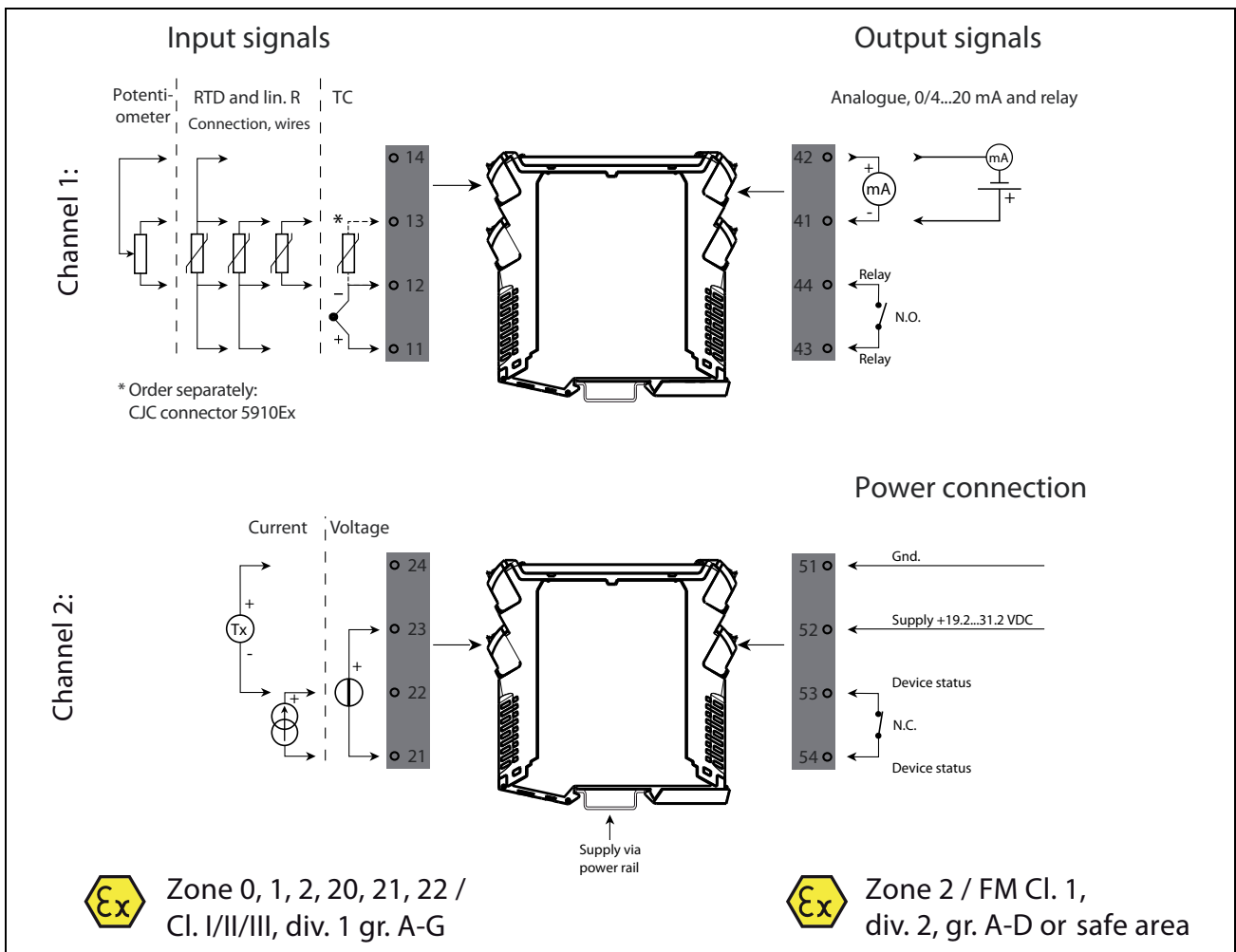

Illustration 7-12: Applications

Specifications

RTD, linear resistance and potentiometer input

Input type	Min. value	Max. value	Standard
Pt100	-200 °C	+850 °C	IEC 60751
Ni100	-60 °C	+250 °C	DIN 43760
Linear resistance	0 Ω	10 000 Ω	—
Potentiometer	10 Ω	10 000 Ω	—

Input for RTD types	Pt10*, Pt20*, Pt50*, Pt100, Pt200, Pt250, Pt300, Pt400, Pt500, Pt1000, Ni100, Ni120, Ni1000
Cable resistance per wire (max.), RTD	50 Ω
Sensor current, RTD	Nom. 0.2 mA
Effect of sensor cable resistance (3-/4-wire), RTD	< 0.002 Ω / Ω
Sensor error detection, RTD	Programmable ON / OFF
Short circuit detection, RTD	Yes

*No short circuit detection for Pt10, Pt20 and Pt50

*No short circuit detection for Lin.R_0% ≤ app. 18 Ω

TC Input

Type	Min. value	Max. value	Standard
B	+0 °C	+1820 °C	IEC 60584-1
E	-100 °C	+1000 °C	IEC 60584-1
J	-100 °C	+1200 °C	IEC 60584-1
K	-180 °C	+1372 °C	IEC 60584-1
L	-200 °C	+900 °C	DIN 43710
N	-180 °C	+1300 °C	IEC 60584-1
R	-50 °C	+1760 °C	IEC 60584
S	-50 °C	+1760 °C	IEC 60584
T	-200 °C	+400 °C	IEC 60584
U	-200 °C	+600 °C	DIN 43710
W3	0 °C	+2300 °C	ASTM E988-90
W5	0 °C	+2300 °C	ASTM E988-90
LR	-200 °C	+800 °C	GOST 3044-84

Cold junction compensation (CJC):

CJC via external sensor in
connector ACT20X CJC 116064

20...28 °C $\leq \pm 1$ °C
-20...20 °C and 28...60 °C $\leq \pm 2$ °C

CJC via internal sensor

$\pm(2.0 \text{ °C} + 0.4 \text{ °C} * \Delta t)$

Δt = internal temperature – ambient temperature

Sensor error detection

Programmable ON or OFF (wire breakage)

Sensor error current:

When detecting

Nom. 2 μ A

Else

0 μ A

Current Input

Measurement range 0...20 mA

Programmable
measurement ranges 0...20 and 4...20 mA

Input resistance Nom. 20 Ω + PTC 50 Ω

Sensor error detection:

Loop break 4...20 mA Yes

Only when input is selected as 4...20 mA

Voltage Input

Measurement range	0...12 V DC
Programmable measurement ranges	0...1 / 0.2...1 / 0...5 / 1...5 / 0...10 and 2...10 V DC
Input resistance	Nom. >10 M Ω

Output

Signal range (span)	0...23 mA
Programmable signal ranges	0...20 / 4...20 / 20...0 and 20...4 mA
Load (max.)	20 mA / 600 Ω / 12 V DC
Load stability	\leq 0.01 % of span / 100 Ω
Sensor error detection	0 / 3.5 / 23 mA / none
NAMUR NE 43 Upscale / Downscale	23 mA / 3.5 mA
Output limitation:	
on 4...20 and 20...4 mA signals	3.8...20.5 mA
on 4...20 and 20...4 mA signals	0...20.5 mA
Current limit	\leq 28 mA

2-wire 4...20 mA Output

Signal range	4...20 mA
Load stability	\leq 0.01 % of span / 100 Ω
Load resistance	$\leq (V_{\text{supply}}-3.5) / 0.023 \text{ A } [\Omega]$
Max. external 2-wire supply	26 V DC
Effect of external 2-wire supply voltage variation	< 0.005 % of span / V

Relay Output

Relay functions	Setpoint, Window, Sensor error, Power and Off
Hysteresis in % / display counts	0.1...25 % / 1...2999
On and Off delay	0...3600 s
Sensor error detection	Break / Make / Hold

	Safe Area	Zone 2 Installation
Voltage max.	250 V AC / 30 V DC	32 V AC / 30 V DC
Power max.	500 VA / 60 W	64 VA / 60 W
Current max.	2 A AC / 2 A DC	2 A AC / 2 A DC

Status Relay

	Safe Area	Zone 2 Installation
Voltage max.	125 V AC / 110 V DC	32 V AC / 30 V DC
Power max.	62.5 VA / 32 W	16 VA / 32 W
Current max.	0.5 A AC / 0.3 A DC	0,5 A AC / 1 A DC

Common Specifications

Supply voltage, DC	19.2...31.2 V DC
Max. consumption	≤ 3.5 W
Fuse	1.25 A / 250 V AC
Isolation voltage, test / operation	2.6 kV AC / 250 V AC
Communications interface	CBX200 (Order no.: 8978580000)
Signal/Noise ratio	Min. 60 dB (0...100 kHz)
Response time (0...90 %, 100...10 %):	
Temperature input, programmable	1...60 s
mA / V input, programmable	0.4...60 s

Isolation

Input to any	300 V AC double / reinforced isolation
Output relay to analogue output	150 V AC double / reinforced or 300 V AC basic isolation
Analogue output to supply	300 V AC double / reinforced isolation
Status relay to supply	150 V AC double / reinforced or 300 V AC basic isolation

Environmental Specifications

Ambient temperature	-20...+60 °C
Storage temperature	-20...+85 °C
Relative humidity	< 95 % (non-cond.)
Calibration temperature	20...28 °C

General Specifications

Dimensions (H x W x D)	105.6 x 22.5 x 114.7 mm
Protection degree	IP 20
Screw terminal torque	0.5 Nm
Vibration, IEC 60068-2-6	test Fc, 1g, 2...100 Hz
Vibration, continuous, IEC 60068-2-64	test Fh, 1g, 3...100 Hz
Wire Size	AWG 26...14 / 0.13...2.08 mm ² stranded wire
EMC immunity influence	≤ ±0.5 % of span
Extended EMC immunity:	

Accuracy

General Values

Input Type	Absolute Accuracy	Temperature Coefficient
All	≤ ±0.1 % of span	≤ ±0.01 % of span / °C

Basic Values

Input Type	Absolute Accuracy	Temperature Coefficient
mA	$\leq \pm 16 \mu\text{A}$	$\leq \pm 0.16 \mu\text{A} / ^\circ\text{C}$
Volt	$\leq \pm 20 \mu\text{A}$	$\leq \pm 2 \mu\text{A} / ^\circ\text{C}$
Pt100, Pt200, Pt1000	$\leq \pm 0.2 ^\circ\text{C}$	$\leq \pm 0.02 \text{ C} / ^\circ\text{C}$
Pt500, Ni100, Ni120, Ni1000	$\leq \pm 0.3 ^\circ\text{C}$	$\leq \pm 0.03 \text{ C} / ^\circ\text{C}$
Pt50, Pt400, Ni50	$\leq \pm 0.4 ^\circ\text{C}$	$\leq \pm 0.04 \text{ C} / ^\circ\text{C}$
Pt250, Pt300	$\leq \pm 0.6 ^\circ\text{C}$	$\leq \pm 0.06 \text{ C} / ^\circ\text{C}$
Pt20	$\leq \pm 0.8 ^\circ\text{C}$	$\leq \pm 0.08 \text{ C} / ^\circ\text{C}$
Pt10	$\leq \pm 1.4 ^\circ\text{C}$	$\leq \pm 0.14 \text{ C} / ^\circ\text{C}$
TC type: E, J, K, L, N, T, U	$\leq \pm 1 ^\circ\text{C}$	$\leq \pm 0.1 \text{ C} / ^\circ\text{C}$
TC type: R, S, W3, W5, LR	$\leq \pm 2 ^\circ\text{C}$	$\leq \pm 0.2 \text{ C} / ^\circ\text{C}$
TC type: B 160...400 °C	$\leq \pm 4.5 ^\circ\text{C}$	$\leq \pm 0.45 \text{ C} / ^\circ\text{C}$
TC type: B 400...1820 °C	$\leq \pm 2 ^\circ\text{C}$	$\leq \pm 0.2 \text{ C} / ^\circ\text{C}$

Default Settings

Input Parameters

Input type	Temperature
Connection Type	3 wire
Temperature Unit	$^\circ\text{C}$
Temperature Sensor Type	Temperature
PT Type	PT 100
Temperature Range	0...150 $^\circ\text{C}$

Output Parameters

Output Current Range	4...20 mA
Output Current on Error	23 mA

Relay Parameters

Function	SETPOINT
Contact function	Normal Open
Setpoint	50 °C (input type temperature) / 50 %
Activation direction	Increasing
Hysteresis	1 °C (input type temperature) / 1 %
Action on error	Relay OPEN
Activation delay [s]	0
Deactivation delay [s]	0

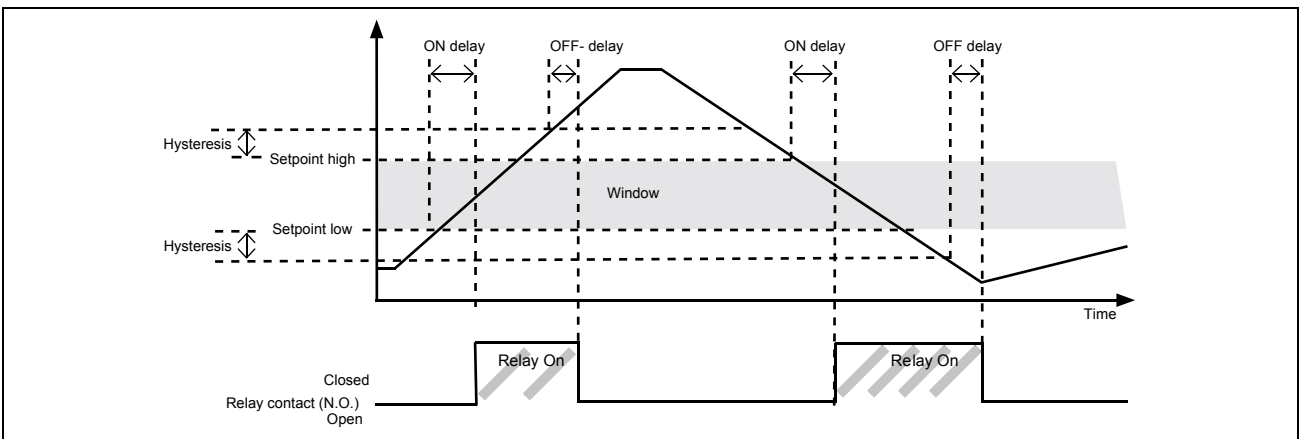

Illustration 7-13: Graphic depiction of window

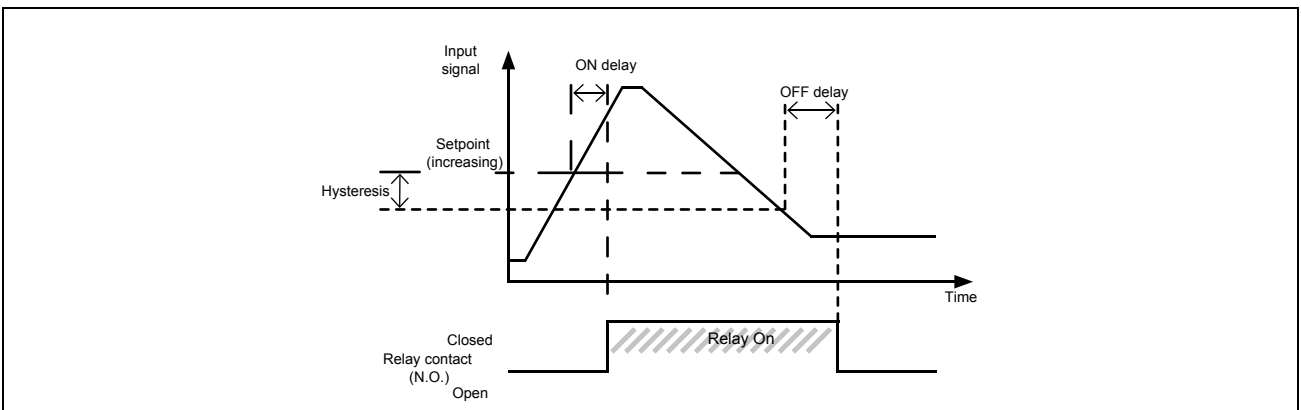

Illustration 7-14: Graphic depiction of setpoint

Appendix

Appendix A. Installation drawings ACT20X-HDI-SDO

IECEX Installation drawing

ACT20X-HDI-SDO NAMUR Pulse Isolator

The module is available in the following variants:

Order No.	Installation Drawing No. IECEX	Type
8965340000	4 50102 Bl. 3-4	ACT20X-HDI-SDO-RNO-S
8965350000	4 50102 Bl. 3-4	ACT20X-HDI-SDO-RNC-S
8965360000	4 50588 Bl. 3-4	ACT20X-HDI-SDO-S
8965370000	4 50589 Bl. 3-4	ACT20X-2HDI-2SDO-RNO-S
8965380000	4 50589 Bl. 3-4	ACT20X-2HDI-2SDO-RNC-S
8965390000	4 50590 Bl. 3-4	ACT20X-2HDI-2SDO-S

	DANGER
	<p>For safe installation of ACT20X-HDI-SDO the following must be observed: The module may only be installed by qualified personnel familiar with the national and international laws, directives and standards that apply to this region.</p>

The year of manufacture can be taken from the first two digits in the serial number.

CBX200 – WI-Manager Software

For installation in Zone 2 / Division 2 the following must be observed:

- The CBX200 is an interface cable for software.
- Configuration must be performed only in a safe area.

IECEX Certificate

IECEX KEM 09.0072 X

Marking

Ex nA nC IIC T4 Gc
 [Ex ia Ga] IIC / IIB / IIA
 [Ex ia Da] IIIC

Standards

IEC60079-15: 2005, IEC60079-11: 2006, IEC60079-0: 2007
 IEC60079-26: 2006, IEC61241-0: 2004, IEC61241-11: 2005

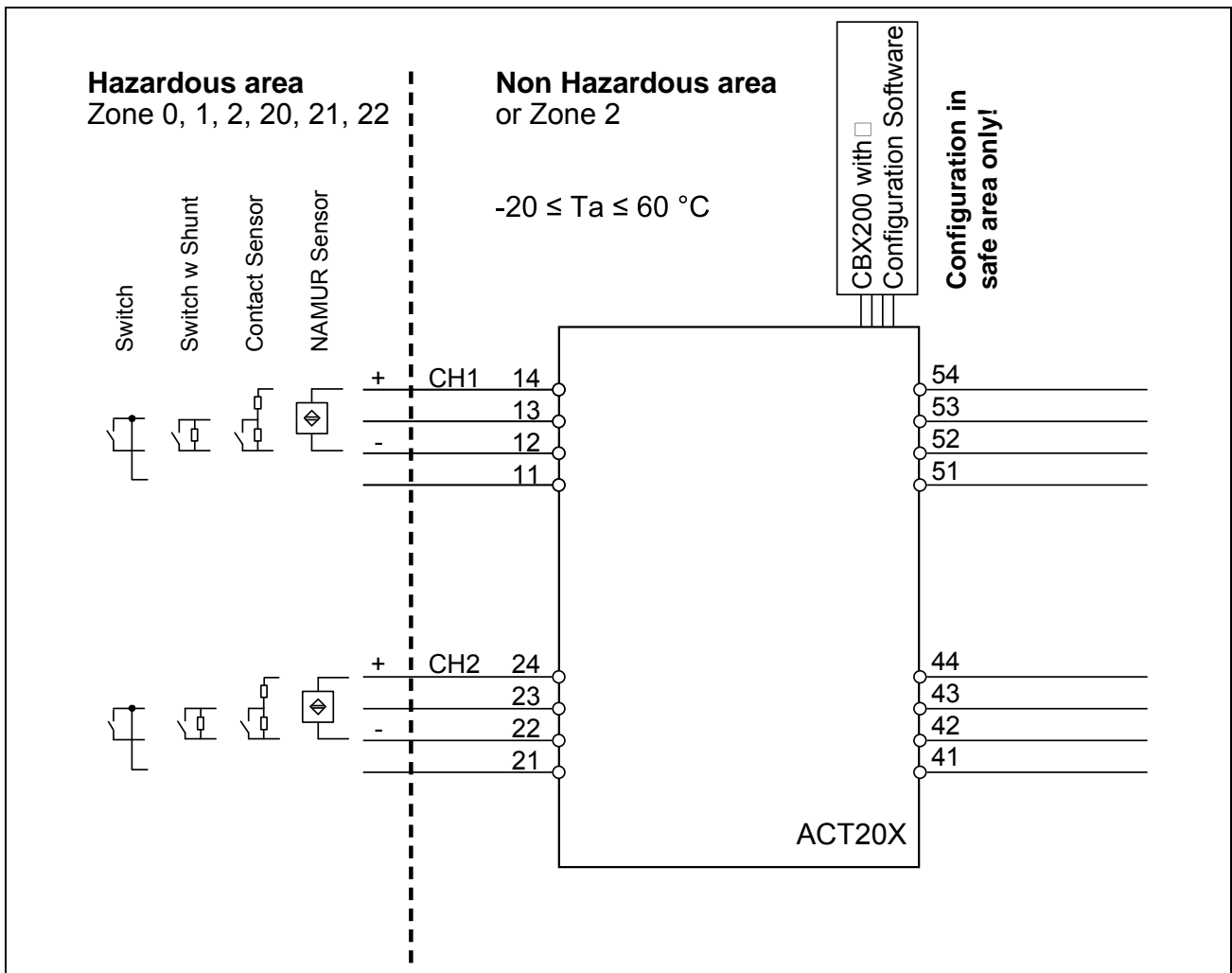

Illustration 7-15: IECEx Installation Drawing

Ex Input

CH1 (terminal 11, 12, 13, 14)

CH2 (terminal 21, 22, 23, 24)

U_o : 10.6 V DC

I_o : 12 mA DC

P_o : 32 mW

L_o/R_o : 1150 μ H/ Ω

Supply / Output

(terminal 51...54)

(terminal 41...44)

U_m : 253 V, max. 400 Hz

	IIC	IIB	IIA
C_o .	2.0 μ F	6.0 μ F	18 μ F
L_o .	260 mH	780 mH	1000 mH

Terminal (51,52)

Supply:

Voltage	19.2...31.2 V DC
Power max.	3 W

Terminal (53,54)

Status Relay:	Non Hazardous location	Zone 2 installation
Voltage max.	125 V AC / 110 V DC	32 V AC / 32 V DC
Power max.	62.5 VA / 32 W	16 VA / 32 W
Current max.	0.5 A AC / 0.3 ADC	0.5 A AC / 1 ADC

Terminal CH1 (41,42) CH2 (43,44)

Digital output: NPN output:

Voltage max.	30 V DC
Current max.	80 mA

Terminal CH1 (41,42) CH2 (43,44)

Relay output:	Non Hazardous location	Zone 2 installation
Voltage max.	250 V AC 30 V DC	32 V AC / 30 V DC
Power max.	500 VA / 60 W	64 VA / 60 W
Current max.	2 A AC / 2 ADC	2 A AC / 2 ADC

Installation notes:

	DANGER
	To prevent ignition of explosive atmospheres, disconnect power before servicing and do not separate connectors when energized and an explosive gas mixture is present.

For installation in Zone 2, the module must be installed in an outer enclosure having an IP protection of at least IP54 according to type of protection Ex-n or Ex-e.

In type of protection "intrinsic safety iD" the parameters for intrinsic safety for gas group IIB are applicable.

If the sensor circuits have been installed in a type of protection other than "intrinsic safety", the module must not be re-installed in type of protection "intrinsic safety".

ATEX Installation Drawing

ACT20X-HDI-SDO NAMUR Pulse Isolator

The module is available in the following variants:

Order No.	Installation Drawing No. IEC EX	Type
8965340000	4 50102 Bl. 1-2	ACT20X-HDI-SDO-RNO-S
8965350000	4 50102 Bl. 1-2	ACT20X-HDI-SDO-RNC-S
8965360000	4 50588 Bl. 1-2	ACT20X-HDI-SDO-S
8965370000	4 50589 Bl. 1-2	ACT20X-2HDI-2SDO-RNO-S
8965380000	4 50589 Bl. 1-2	ACT20X-2HDI-2SDO-RNC-S
8965390000	4 50590 Bl. 1-2	ACT20X-2HDI-2SDO-S

	DANGER
	For safe installation of ACT20X-HDI-SDO the following must be observed: The module may only be installed by qualified personnel familiar with the national and international laws, directives and standards that apply to this region.

The year of manufacture can be taken from the first two digits in the serial number.

CBX200 – WI-Manager Software

For installation in Zone 2 / Division 2 the following must be observed:

- The CBX200 is an interface cable for software.
- Configuration must be performed only in a safe area.

ATEX Certificate

KEMA 09ATEX 0168 X

Marking



II 3 G Ex nA nC IIC T4
II (1) G [Ex ia] IIC / IIB / IIA
II (1) D [Ex iaD]

Standards

EN 60079-0: 2006, EN 60079-11: 2007, EN 60079-15: 2005
EN 60079-26: 2007, EN 61241-0: 2006, EN 61241-11: 2006

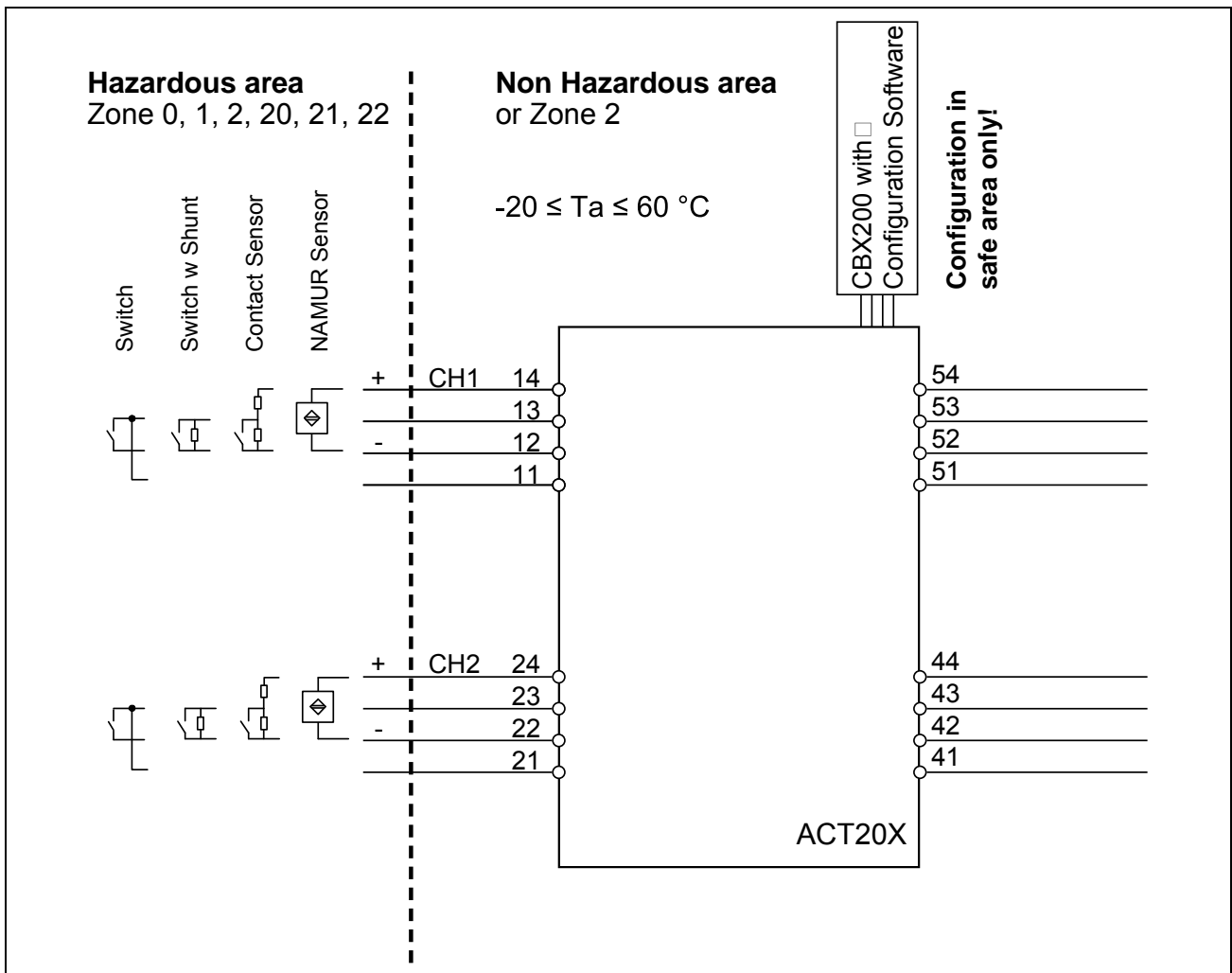

Illustration 7-16: ATEX Installation Drawing

Ex Input

CH1 (terminal 11, 12, 13, 14)

CH2 (terminal 21, 22, 23, 24)

U_o : 10.6 V DC

I_o : 12 mA DC

P_o : 32 mW

L_o/R_o : 1150 μ H/ Ω

Supply / Output

(terminal 51...54)

(terminal 41...44)

U_m : 253 V, max. 400 Hz

	IIC	IIB	IIA
C_o	2.0 μ F	6.0 μ F	18 μ F
L_o	260 mH	780 mH	1000 mH

Terminal (51, 52)

Supply:

Voltage	19.2...31.2 V DC
Power max.	3 W

Terminal (53, 54)

Status Relay:	Non Hazardous location	Zone 2 installation
Voltage max.	125 V AC / 110 V DC	32 V AC / 32 V DC
Power max.	62.5 VA / 32 W	16 VA / 32 W
Current max.	0.5 A AC / 0.3 ADC	0.5 A AC / 1 ADC

Terminal CH1 (41, 42) CH2 (43, 44)

Digital output: NPN output:

Voltage max.	30 V DC
Current max.	80 mA

Terminal CH1 (41, 42) CH2 (43, 44)

Relay output:	Non Hazardous location	Zone 2 installation
Voltage max.	250 V AC / 30 V DC	32 V AC / 30 V DC
Power max.	500 VA / 60 W	64 VA / 60 W
Current max.	2 A AC / 2 ADC	2 A AC / 2 ADC

Installation notes:

	DANGER
	To prevent ignition of explosive atmospheres, disconnect power before servicing and do not separate connectors when energized and an explosive gas mixture is present.

For installation in Zone 2, the module must be installed in an outer enclosure having an IP protection of at least IP54 according to type of protection Ex-n or Ex-e.

In type of protection "intrinsic safety iD" the parameters for intrinsic safety for gas group IIB are applicable.

If the sensor circuits have been installed in a type of protection other than "intrinsic safety", the module must not be re-installed in type of protection "intrinsic safety".

FM Installation drawing

ACT20X-HDI-SDO NAMUR Pulse Isolator

The module is available in the following variants:

Order No.	Installation Drawing No. IECEx	Type
8965340000	4 50102 Bl. 5-6	ACT20X-HDI-SDO-RNO-S
8965350000	4 50102 Bl. 5-6	ACT20X-HDI-SDO-RNC-S
8965360000	4 50588 Bl. 5-6	ACT20X-HDI-SDO-S
8965370000	4 50589 Bl. 5-6	ACT20X-2HDI-2SDO-RNO-S
8965380000	4 50589 Bl. 5-6	ACT20X-2HDI-2SDO-RNC-S
8965390000	4 50590 Bl. 5-6	ACT20X-2HDI-2SDO-S

	DANGER
	For safe installation of ACT20X-HDI-SDO the following must be observed: The module may only be installed by qualified personnel familiar with the national and international laws, directives and standards that apply to this region.

The year of manufacture can be taken from the first two digits in the serial number.

CBX200 – WI-Manager Software

For installation in Zone 2 / Division 2 the following must be observed:

- The CBX200 is an interface cable for software.
- Configuration must be performed only in a safe area.

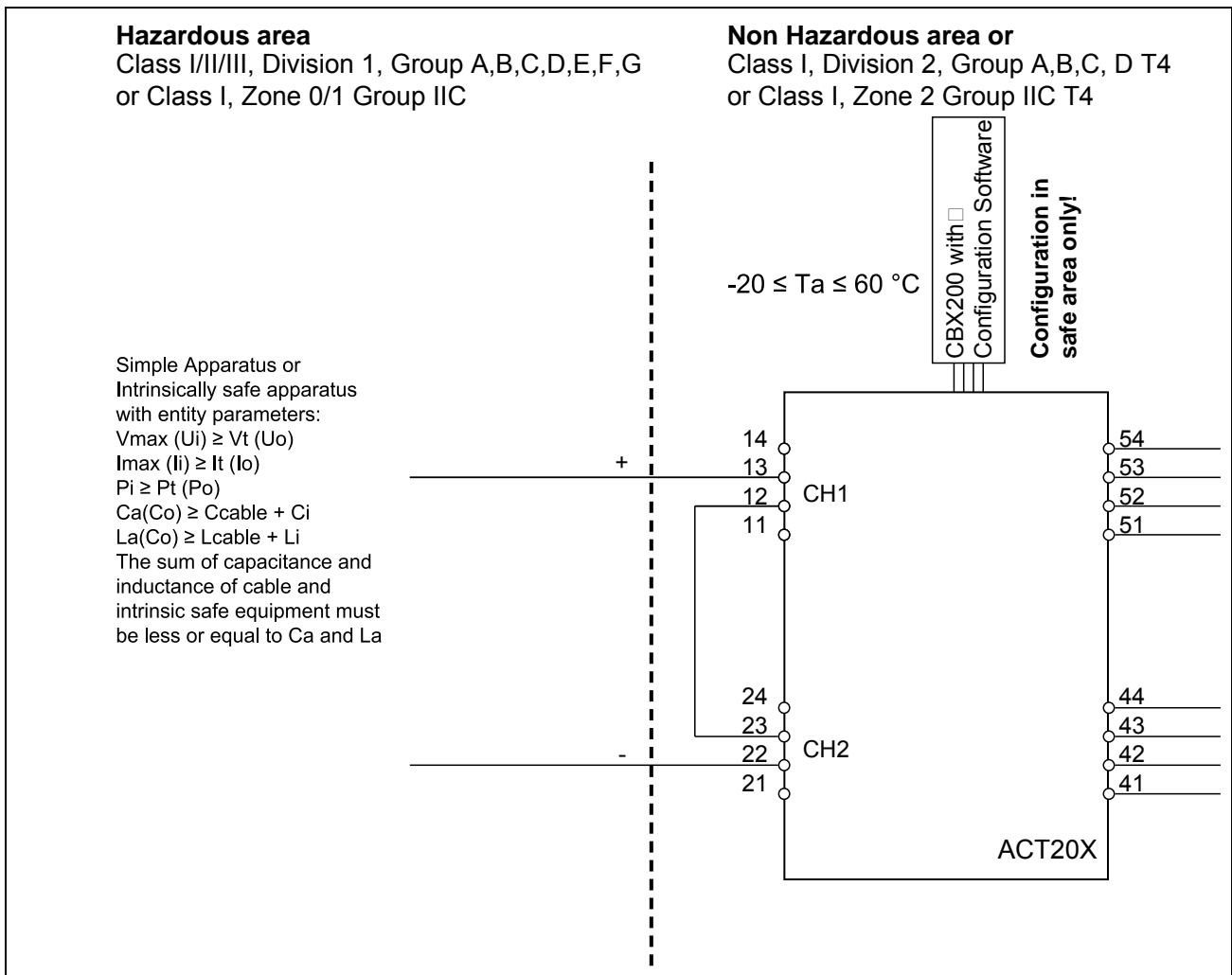

Illustration 7-17: FM Installation Drawing

Ex Input

CH1 (14, 12) CH2 (24, 22)

U_o/V_t : 10.6 V DC

I_o/I_{sc} : 12 mA

P_o/P_t : 32 mW

L_o/R_o L_a/R_a : 1150 $\mu\text{H}/\Omega$

Supply / Output

(terminal 51...54)

(terminal 41...44)

U_m : 253 V, max. 400 Hz

(terminal 51,52)

Supply voltage: 19.2...31.2 V DC

Max. power consumption: 3 W

Group	IIC	IIB	IIA
Group	A,B	C,E,F	D,G
C_o/C_a	2.0 μF	6.0 μF	18 μF
L_o/L_a	260 mH	780 mH	1000 mH

Terminal (53, 54)

Status Relay:	Non Hazardous location	Division 2 or Zone 2 installation
Voltage max.	125 V AC / 110 V DC	32 V AC / 32 V DC
Power max.	62.5 VA / 32 W	16 VA / 32 W
Current max.	0.5 A AC / 0.3 ADC	0.5 A AC / 1 ADC

Terminal CH1 (41, 42) CH2 (43, 44)

Digital output:	NPN output:
Voltage max.	30 V DC
Current max.	80 mA

Terminal CH1 (41, 42) CH2 (43, 44)

Relay output:	Non Hazardous location	Division 2 or Zone 2 installation
Voltage max.	250 V AC / 30 V DC	32 V AC / 30 V DC
Power max.	500 VA / 60 W	64 VA / 60 W
Current max.	2 A AC / 2 ADC	2 A AC / 2 ADC

Installation notes:

	DANGER
	To prevent ignition of explosive atmospheres, disconnect power before servicing and do not separate connectors when energized and an explosive gas mixture is present.

	WARNING
	Substitution of components may impair intrinsic safety and/or suitability for Div. 2/Zone 2.

The installation and wiring must be in accordance with the Canadian Electrical Code for Canada and National Electrical Code NFPA 70, Article 500 or 505 for installation in USA.

The module must be supplied from a Power Supply having double or reinforced insulation.

The use of stranded wires is not permitted for mains wiring except when wires are fitted with cable ends.

The module must be installed in pollution degree 2 or better.

The module must be installed in an enclosure suitable for the environment where it is used.

For installation in Zone 2 or Division 2, the module must be installed in a suitable outer enclosure according to the regulations in the CEC for Canada or NEC for USA.

The module is galvanically isolated and does not require grounding.

Use 60/75 °C copper conductors in the wire size AWG: (26-14).

Appendix B. Installation drawings ACT20X-HTI-SAO

IECEX Installation drawing

Temperature and mA Converter ACT20X-HTI-SAO

The module is available in the following variants:

Order No.	Installation Drawing No. IECEX	Type	Description
8965470000	4 50594 Bl. 3-4	ACT20X-HTI-SAO-S	Temperature/mA converter
8965480000	4 50595 Bl. 4-6	ACT20X-2HTI-2SAO-S	2 ch. temperature/mA converter

	DANGER
	<p>For safe installation of the Temperature and mA Converter ACT20X-HTI-SAO the following must be observed: The module may only be installed by qualified personnel familiar with the national and international laws, directives and standards that apply to this region.</p>

The year of manufacture can be taken from the first two digits in the serial number.

CBX200 – WI-Manager Software

For installation in Zone 2 / Division 2 the following must be observed:

- The CBX200 is an interface cable for software.
- Configuration must be performed only in a safe area.

IECEX Certificate	IECEX KEM 09.0092 X
Marking	Ex nA nC IIC T4 Gc [Ex ia Ga] IIC / IIB / IIA [Ex ia Da] IIIC
Standards	IEC60079-15: 2005, IEC60079-11: 2006, IEC60079-0: 2007 IEC60079-26: 2006, IEC61241-0: 2004, IEC61241-11: 2005

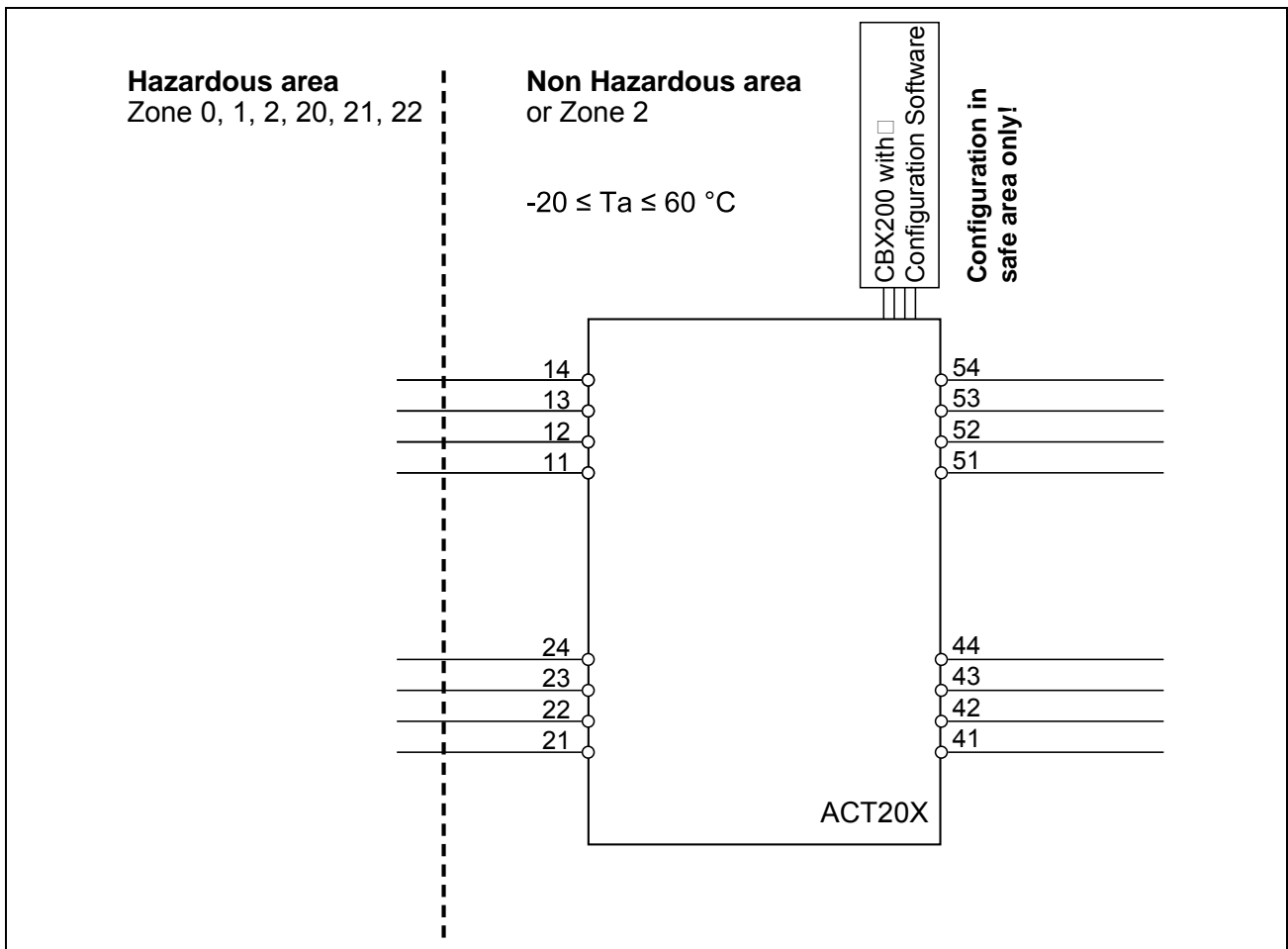

Illustration 7-18: IECEx Installation Drawing

Ex Input

CH1 (terminal 11, 12, 13, 14)

CH2 (terminal 21, 22, 23, 24)

U_o : 8.7 V

I_o : 18.4 mA

P_o : 40 mW

L_o/R_o : 892 $\mu\text{H}/\Omega$

Supply / Output

(terminal 41...44)

(terminal 51...54)

U_m : 253 V, max. 400 Hz

	IIC	IIB	IIA
C_o	5 μF	50 μF	1000 μF
L_o	100 mH	300 mH	700 mH

U_i : 10 V

I_i : 30 mA

C_i : 30 nF

L_i : 820 nH

Terminal (53, 54)

Status Relay:	Non Hazardous location	Zone 2 installation
Voltage max.	125 V AC / 110 V DC	32 V AC / 32 V DC
Power max.	62.5 VA / 32 W	16 VA / 32 W
Current max.	0.5 A AC / 0.3 A DC	0.5 A AC / 1 A DC

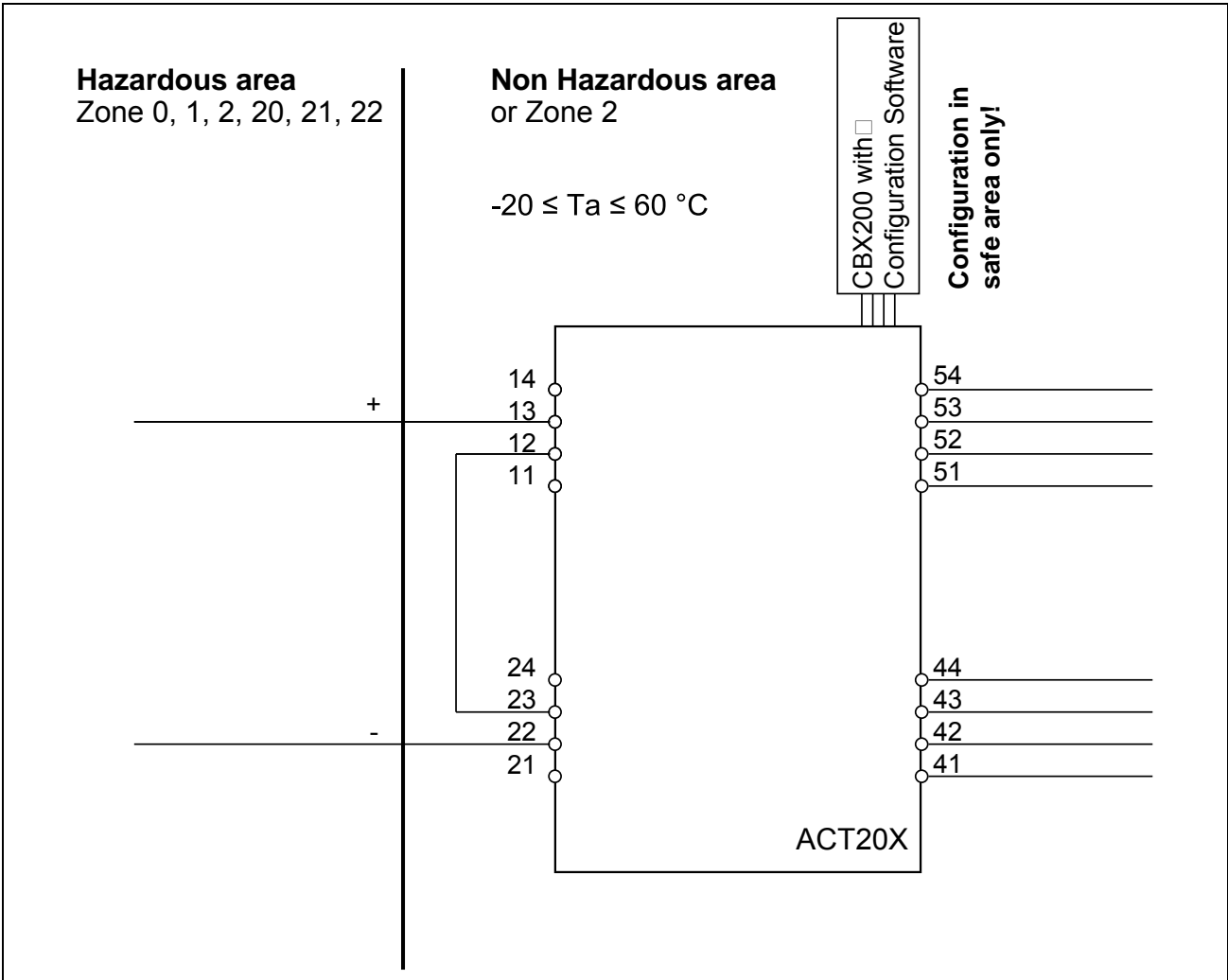

Illustration 7-19: IECEx Installation Drawing

Ex Input

CH1 (terminal 13 +)

CH2 (terminal 22 -)

U_o : 17.4 V

I_o : 18.4 mA

P_o : 80 mW

L_o/R_o : 445 $\mu\text{H}/\Omega$

Supply/Output

(terminal 41...44)

(terminal 51...54)

U_m : 253 V, max. 400 Hz

	IIC	IIB	IIA
C _o .	0.3 μF	1.6 μF	8 μF
L _o .	80 mH	250 mH	600 mH

U_i: 10 V

I_i: 30 mA

C_i: 15 nF

L_i: 1.7 μH

Installation notes:

	DANGER
	To prevent ignition of explosive atmospheres, disconnect power before servicing and do not separate connectors when energized and an explosive gas mixture is present.

For installation in Zone 2, the module must be installed in an outer enclosure having an IP protection of at least IP54 conforming to the requirements of IEC60079-15.

In type of protection “intrinsic safety iD” the parameters for intrinsic safety for gas group IIB are applicable.

If the sensor circuits have been installed in a type of protection other than “intrinsic safety”, the module must not be re-installed in type of protection “intrinsic safety”.

ATEX Installation Drawing

Temperature and mA Converter ACT20X-HTI-SAO

The module is available in the following variants:

Order No.	Installation Drawing No. IECEx	Type	Description
8965470000	4 50594 Bl. 1-3	ACT20X-HTI-SAO-S	Temperature/mA converter
8965480000	4 50595 Bl. 1-3	ACT20X-2HTI-2SAO-S	2 ch. temperature/mA converter

	DANGER
	For safe installation of the Temperature and mA Converter ACT20X-HTI-SAO the following must be observed: The module may only be installed by qualified personnel familiar with the national and international laws, directives and standards that apply to this region.

The year of manufacture can be taken from the first two digits in the serial number.

CBX200 – WI-Manager Software

For installation in Zone 2 / Division 2 the following must be observed:

- The CBX200 is an interface cable for software.
- Configuration must be performed only in a safe area.

ATEX Certificate

KEMA 10ATEX 0020 X

Marking



II 3 G Ex nA nC IIC T4
II (1) G [Ex ia] IIC/IIB / IIA
II (1) D [Ex iaD]

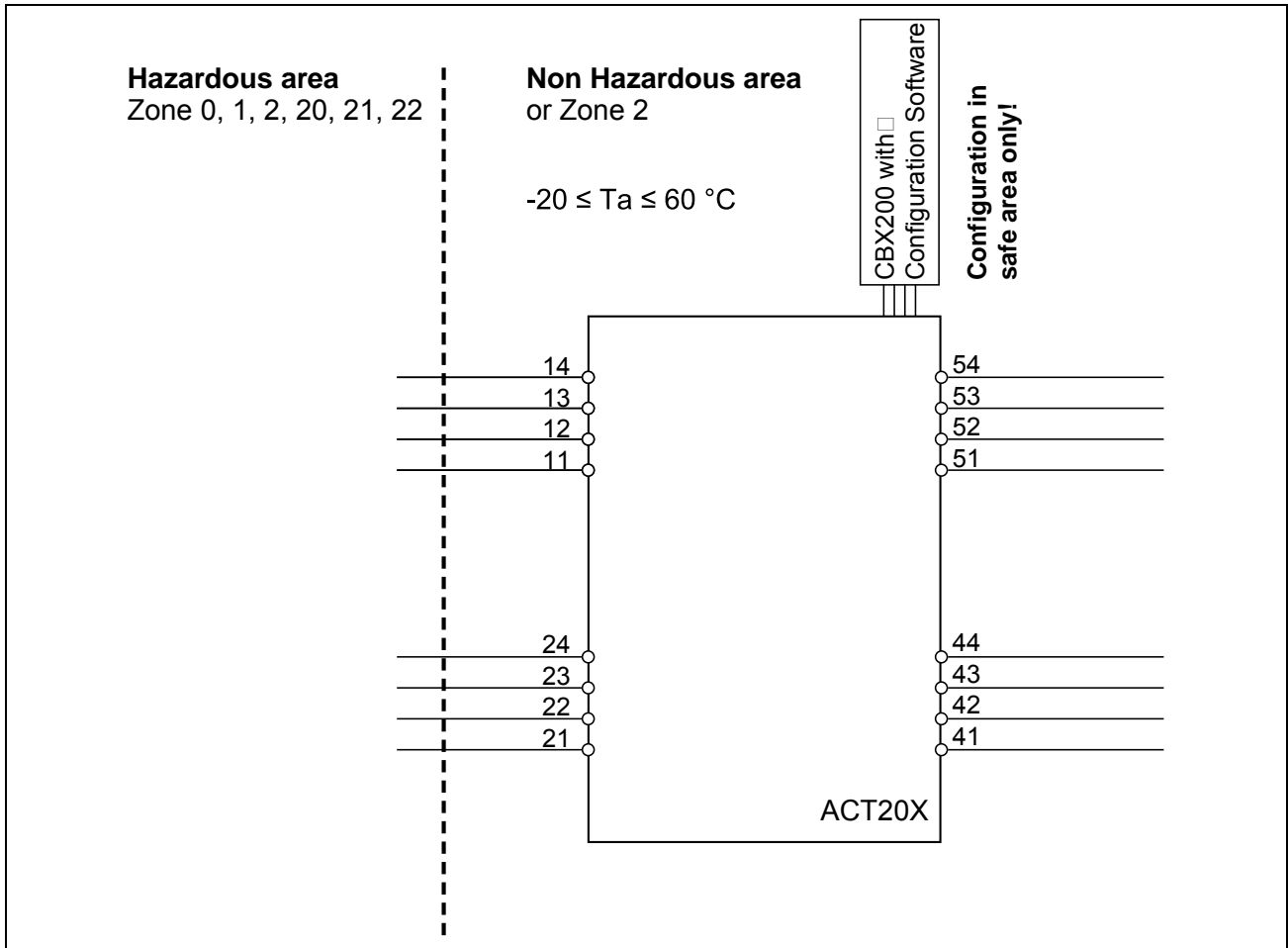

Illustration 7-20: ATEX Installation Drawing

Ex Input

CH1 (terminal 11, 12, 13, 14)

CH2 (terminal 21, 22, 23, 24)

U_o : 8.7 V DC

I_o : 18.4 mA DC

P_o : 40 mW

L_o/R_o : 892 $\mu\text{H}/\Omega$

Supply / Output

(terminal 41...44)

(terminal 51...54)

U_m : 253 V, max. 400 Hz

	IIC	IIB	IIA
C_o	5 μF	50 μF	1000 μF
L_o	100 mH	300 mH	700 mH

U_i : 10 V

I_i : 30 mA

C_i : 30 nF

L_i : 820 μH

Terminal (53, 54)

Status Relay:	Non Hazardous location	Zone 2 installation
Voltage max.	125 V AC / 110 V DC	32 V AC / 32 V DC
Power max.	62.5 VA / 32 W	16 VA / 32 W
Current max.	0.5 A AC / 0.3 A DC	0.5 A AC / 1 A DC

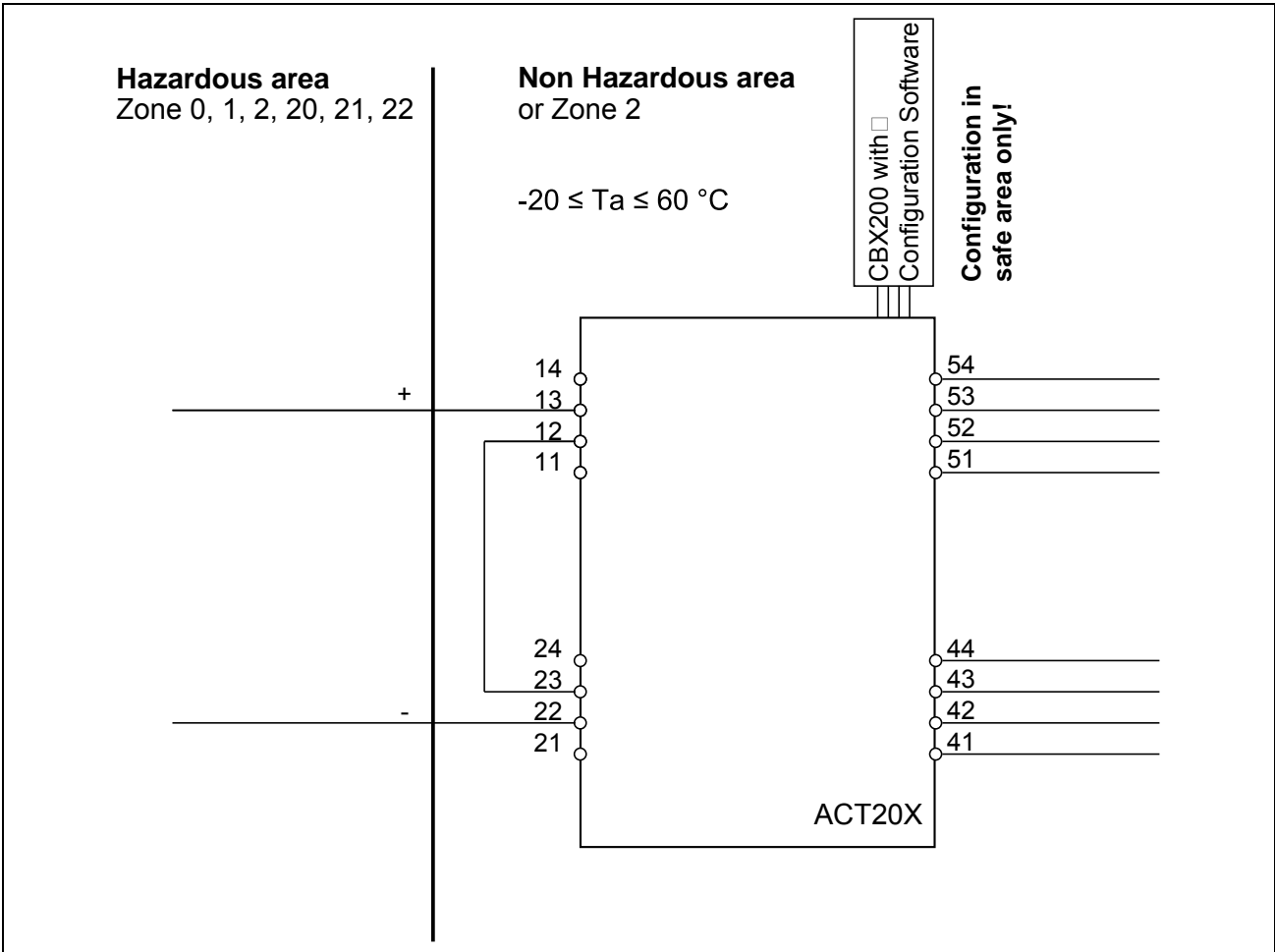

Illustration 7-21: ATEX Installation Drawing

Ex Input

CH1 (terminal 13)

CH2 (terminal 22)

U_o : 17.4 V DC

I_o : 18.4 mA DC

P_o : 80 mW

L_o/R_o : 445 $\mu\text{H}/\Omega$

Supply / Output

(terminal 41...44)

(terminal 51...54)

U_m : 253 V, max. 400 Hz

	IIC	IIB	IIA
C_o	0.3 μ F	1.6 μ F	8 μ F
L_o	80 mH	250 mH	600 mH

U_i : 10 V

I_i : 30 mA

C_i : 15 nF

L_i : 1.7 μ H

Installation notes:

	DANGER
	To prevent ignition of explosive atmospheres, disconnect power before servicing and do not separate connectors when energized and an explosive gas mixture is present.

For installation in Zone 2, the module must be installed in an outer enclosure having an IP protection of at least IP54 conforming to the requirements of IEC60079-15.

In type of protection "intrinsic safety iD" the parameters for intrinsic safety for gas group IIB are applicable.

If the sensor circuits have been installed in a type of protection other than "intrinsic safety", the module must not be re-installed in type of protection "intrinsic safety".

FM Installation drawing

Temperature and mA Converter ACT20X-HTI-SAO

The module is available in the following variants:

Order No.	Installation Drawing No. IECEX	Type	Description
8965470000	4 50594 Bl. 7-9	ACT20X-HTI-SAO-S	Temperature/mA converter
8965480000	4 50595 Bl. 7-9	ACT20X-2HTI-2SAO-S	2 ch. temperature/mA converter

	DANGER
	For safe installation of the Temperature and mA Converter ACT20X-HTI-SAO the following must be observed: The module may only be installed by qualified personnel familiar with the national and international laws, directives and standards that apply to this region.

The year of manufacture can be taken from the first two digits in the serial number.

CBX200 – WI-Manager Software

For installation in Zone 2/Division 2 the following must be observed:

- The CBX200 is an interface cable for software.
- Configuration must be performed only in a safe area.

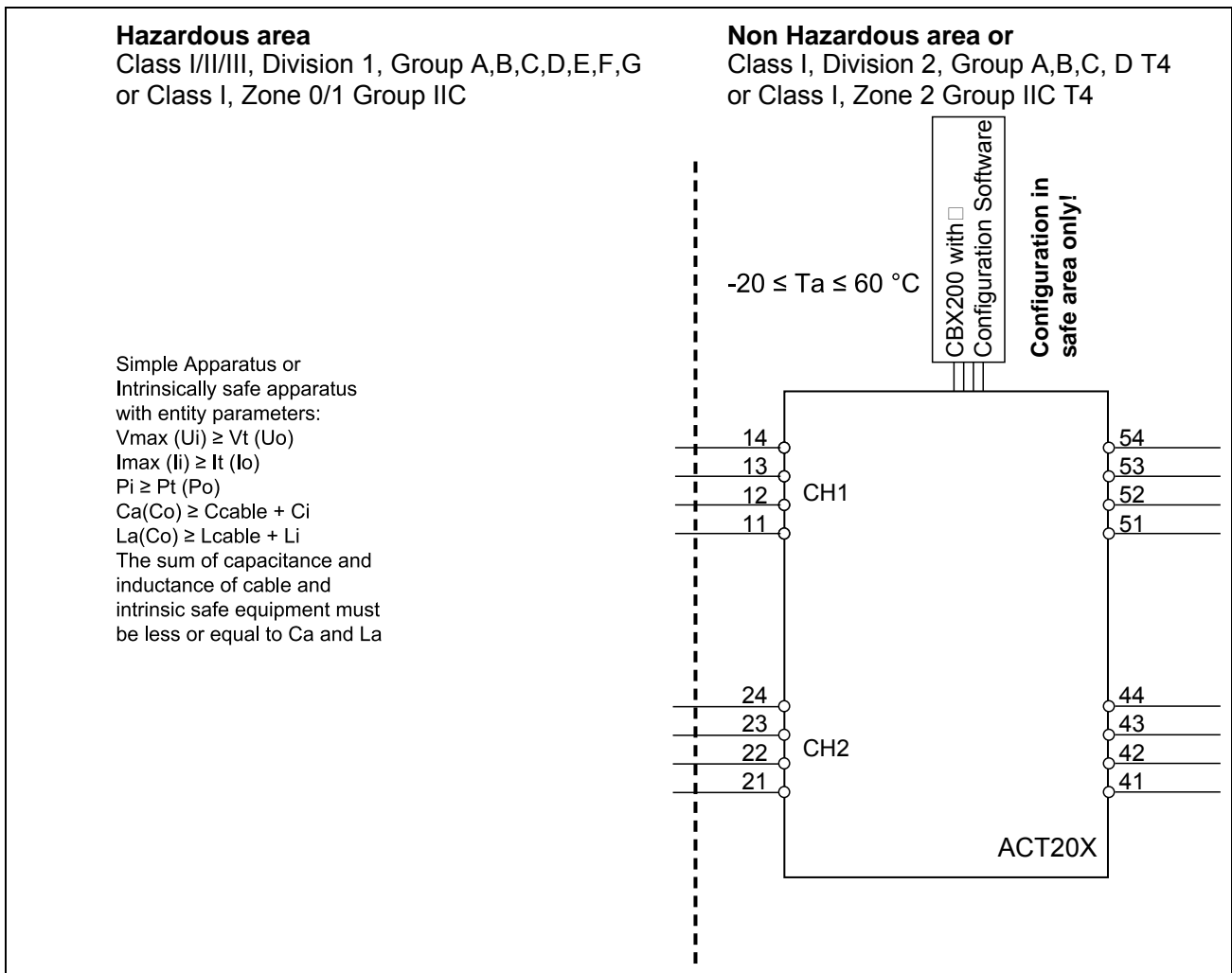

Illustration 7-22: FM Installation Drawing

Ex Input

CH1 (terminal 11, 12, 13, 14)

CH2 (terminal 21, 22, 23, 24)

$V_t(U_o)$: 8.7 V

$I_t(I_o)$: 18.4 mA

P_o : 40 mW

L_o/R_o : 892 $\mu\text{H}/\Omega$

Supply / Output

(terminal 41...44)

(terminal 51...54)

U_m : 253 V, max. 400 Hz

Group	IIC	IIB	IIA
Group	A,B	C,E,F	D,G
C_a/C_o .	5 μF	50 μF	1000 μF
L_a/L_o .	100 mH	300 mH	700 mH

U_i : 10 V
 I_i : 30 mA
 C_i : 30 nF
 L_i : 820 μ H

Terminal (53, 54)

Status Relay:	Non Hazardous location	Zone 2 installation
Voltage max.	125 V AC / 110 V DC	32 V AC / 32 V DC
Power max.	62.5 VA / 32 W	16 VA / 32 W
Current max.	0.5 A AC / 0.3 A DC	0.5 A AC / 1 A DC

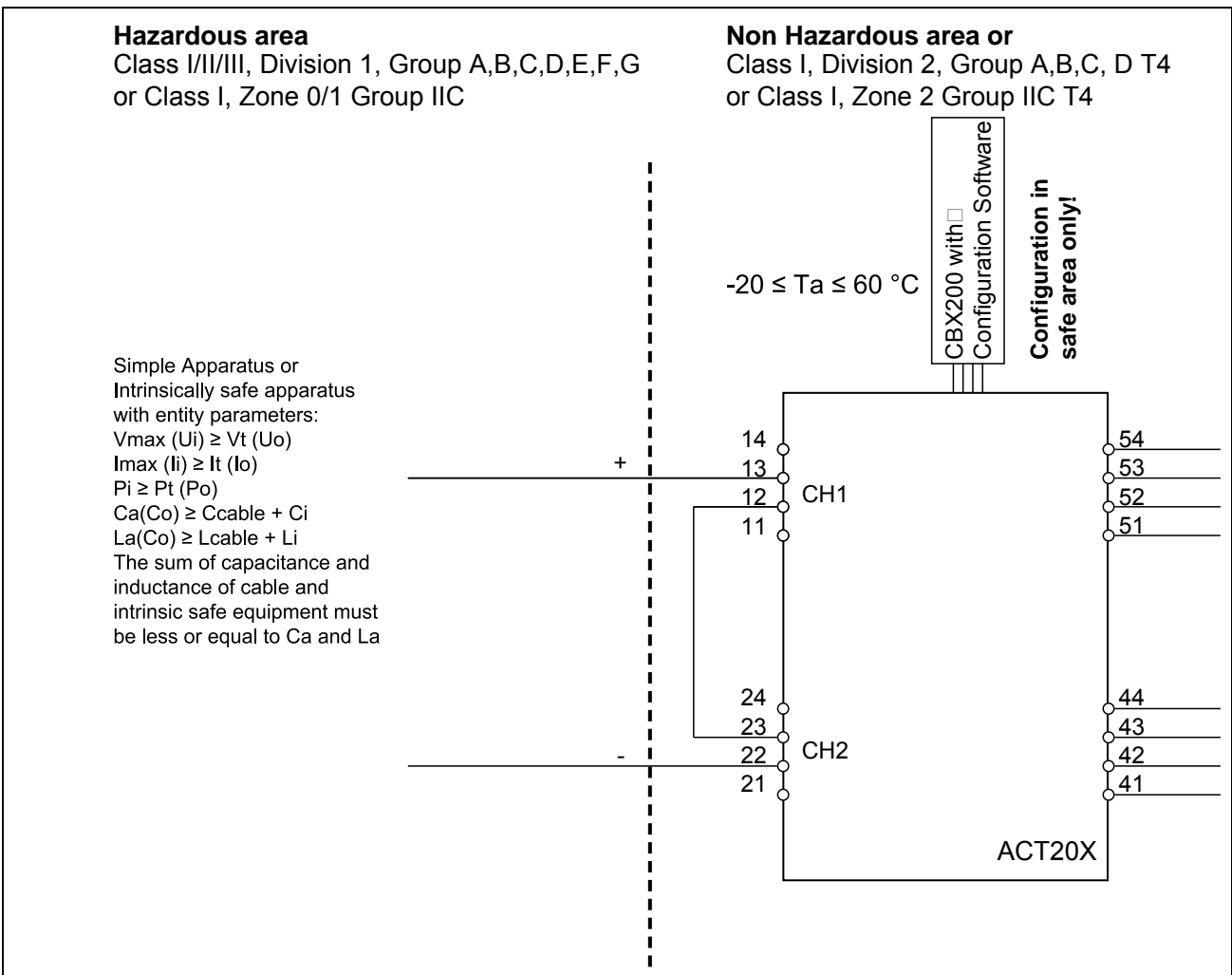



Illustration 7-23: FM Installation Drawing

Ex Input**CH1 (terminal 12, 13)****CH2 (terminal 22, 23)** $V_t (U_o): 17.4 \text{ V}$ $I_t (I_o): 18.4 \text{ mA}$ $P_o: 80 \text{ mW}$ $L_o/R_o: 445 \mu\text{H}/\Omega$ **Supply / Output****(terminal 41...44)****(terminal 51...54)** $U_m: 253 \text{ V, max. } 400 \text{ Hz}$

Group	IIC	IIB	IIA
Group	A,B	C,E,F	D,G
C_o/C_a	0.3 μF	1.6 μF	8 μF
L_o/L_a	80 mH	250 mH	600 mH

 $U_i: 10 \text{ V}$ $I_i: 30 \text{ mA}$ $C_i: 15 \text{ nF}$ $L_i: 1.7 \mu\text{H}$ **Installation notes:**

	DANGER
	To prevent ignition of explosive atmospheres, disconnect power before servicing and do not separate connectors when energized and an explosive gas mixture is present.

	WARNING
	Substitution of components may impair intrinsic safety and/or suitability for Div. 2/Zone 2.

The installation and wiring must be in accordance with the Canadian Electrical Code for Canada and National Electrical Code NFPA 70, Article 500 or 505 for installation in USA.

The module must be supplied from a Power Supply having double or reinforced insulation.

The use of stranded wires is not permitted for mains wiring except when wires are fitted with cable ends.

The module must be installed in pollution degree 2 or better.

The module must be installed in an enclosure suitable for the environment where it is used.

For installation in Zone 2 or Division 2, the module must be installed in a suitable outer enclosure according to the regulations in the CEC for Canada or NEC for USA.

The module is galvanically isolated and does not require grounding.

Use 60/75 °C copper conductors in the wire size AWG: (26-14).

Appendix C. Installation drawings ACT20X-SDI-HDO

IECEX Installation drawing

ACT20X-SDI-HDO Solenoid / Alarm Driver

The module is available in the following variants:

Order No.	Installation Drawing No. IECEX	Type	Description
8965400000	4 51478 Bl. 3-4	ACT20X-SDI-HDO-L-S	solenoid / alarm driver, L = low current max. 35 mA
8965410000	4 51478 Bl. 3-4	ACT20X-SDI-HDO-H-S	solenoid / alarm driver, H = high current max. 60 mA
8965420000	4 51478 Bl. 3-4	ACT20X-2SDI-2HDO-S	2-channel solenoid / alarm driver, L = low current max. 35 mA



DANGER

For safe installation of ACT20X-SDI-HDO the following must be observed: The module may only be installed by qualified personnel familiar with the national and international laws, directives and standards that apply to this region.

The year of manufacture can be taken from the first two digits in the serial number.

CBX200 – WI-Manager Software

For installation in Zone 2 / Division 2 the following must be observed:

- The CBX200 is an interface cable for software.
- Configuration must be performed only in a safe area.

IECEX Certificate

IECEX KEM 09.0071 X

Marking

Ex nA nC IIC T4 Gc
[Ex ia Ga] IIC / IIB / IIA
[Ex ia Da] IIIC

Standards

IEC60079-15: 2005, IEC60079-11: 2006, IEC60079-0: 2007
IEC60079-26: 2006, IEC61241-0: 2004, IEC61241-11: 2005

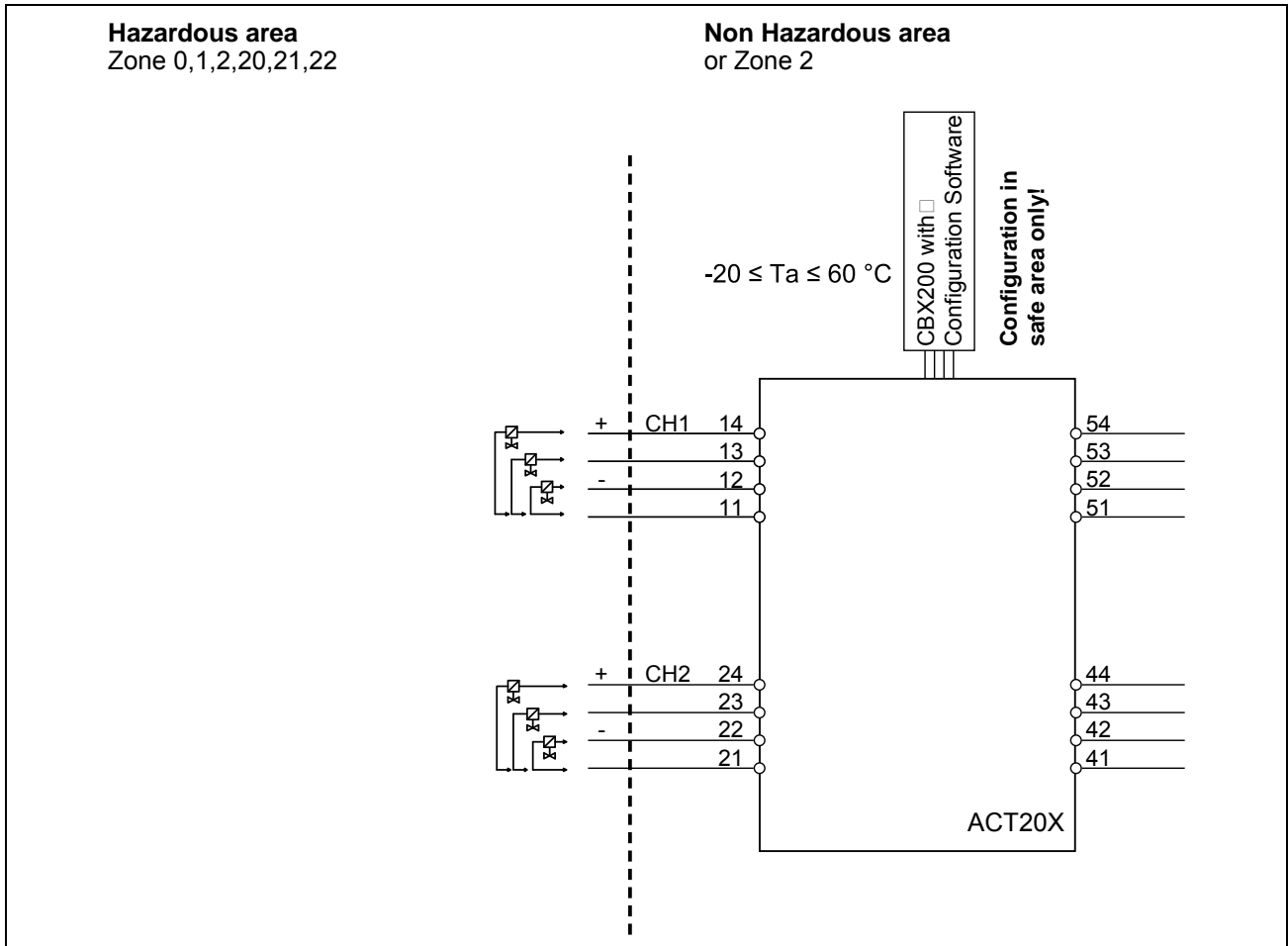

Illustration 7-24: IECEx Installation Drawing

Supply / Input

CH1 (terminal 41, 42, 43, 44)

CH2 (terminal 51, 52, 53, 54)

U_m : 253 V, max. 400 Hz

896540 (ACT20X-SDI-HDO-L-S), 896542 (ACT20X-2SDI-2HDO-S), Terminal 11–12 / 21–22			Co	Lo	Lo/Ro
U_o	28 V	IIC	80 nF	4.2 mH	54 $\mu\text{H}/\Omega$
I_o	93 mA	IIB	640 nF	16.8 mH	218 $\mu\text{H}/\Omega$
P_o	0.65 W	IIA	2.1 μF	32.6 mH	436 $\mu\text{H}/\Omega$

896540 (ACT20X-SDI-HDO-L-S), 896542 (ACT20X-2SDI-2HDO-S), Terminal 11–13 / 21–23			Co	Lo	Lo/Ro
U_o	28 V	IIC	80 nF	3.5 mH	50 $\mu\text{H}/\Omega$
I_o	100 mA	IIB	640 nF	14.2 mH	201 $\mu\text{H}/\Omega$
P_o	0.70 W	IIA	2.1 μF	27.6 mH	402 $\mu\text{H}/\Omega$

896540 (ACT20X-SDI-HDO-L-S), 896542 (ACT20X-2SDI-2HDO-S), Terminal 11–14 / 21–24			Co	Lo	Lo/Ro
Uo	28 V	IIC	80 nF	2.9 mH	46 µH/Ω
Io	110 mA	IIB	640 nF	12.8 mH	184 µH/Ω
Po	0.77 W	IIA	2.1 µF	22.8 mH	369 µH/Ω

896541 (ACT20X-SDI-HDO-H-S), Terminal 11–12			Co	Lo	Lo/Ro
Uo	28 V	IIC	80 nF	2.69 mH	44 µH/Ω
Io	115 mA	IIB	640 nF	10.8 mH	176 µH/Ω
Po	0.81 W	IIA	2.1 µF	20.8 mH	353 µH/Ω

896541 (ACT20X-SDI-HDO-H-S), Terminal 11–13			Co	Lo	Lo/Ro
Uo	28 V	IIC	–	–	–
Io	125 mA	IIB	640 nF	9.1 mH	162 µH/Ω
Po	0.88 W	IIA	2.1 µF	17.6 mH	325 µH/Ω

896541 (ACT20X-SDI-HDO-H-S), Terminal 11–14			Co	Lo	Lo/Ro
Uo	28 V	IIC	–	–	–
Io	135 mA	IIB	640 nF	7.8 mH	150 µH/Ω
Po	0.95 W	IIA	2.1 µF	15.1 mH	301 µH/Ω

Terminal (51,52)

Supply:

Voltage 19.2...31.2 V DC

Power max. 3.5 W

Terminal CH1 (41,42) CH2 (43,44)

Input:

Voltage Max 28 V DC

Trigger: NPN Low < 2 V, High > 4 V

Trigger: PNP Low < 8 V, High > 10 V

Terminal (53,54)

Status Relay: **Non Hazardous location** **Zone 2 installation**

Voltage max. 125 V AC / 110 V DC 32 V AC / 32 V DC

Power max. 62.5 VA / 32 W 16 VA / 32 W

Current max. 0.5 A AC / 0.3 ADC 0.5 A AC / 1 ADC

Installation notes:

	DANGER
To prevent ignition of explosive atmospheres, disconnect power before servicing and do not separate connectors when energized and an explosive gas mixture is present.	

For installation in Zone 2, the module must be installed in an outer enclosure having an IP protection of at least IP54 according to type of protection Ex-n or Ex-e.

In type of protection "intrinsic safety iD" the parameters for intrinsic safety for gas group IIB are applicable.

If the sensor circuits (terminals 11–14, 21–22) have been installed in a type of protection other than "intrinsic safety", the module must not be re-installed in type of protection "intrinsic safety".

The maximum internal Power dissipation for adjacent modules is assumed to be max. 2 W each.

ATEX Installation Drawing

ACT20X-SDI-HDO Solenoid / Alarm Driver

The module is available in the following variants:

Order No.	Installation Drawing No. IECEx	Type	Description
8965400000	4 51478 Bl. 1-2	ACT20X-SDI-HDO-L-S	solenoid / alarm driver, L = low current max. 35 mA
8965410000	4 51478 Bl. 1-2	ACT20X-SDI-HDO-H-S	solenoid / alarm driver, H = high current max. 60 mA
8965420000	4 51478 Bl. 1-2	ACT20X-2SDI-2HDO-S	2-channel solenoid / alarm driver, L = low current max. 35 mA

DANGER
 <p>For safe installation of ACT20X-SDI-HDO the following must be observed: The module may only be installed by qualified personnel familiar with the national and international laws, directives and standards that apply to this region.</p>

The year of manufacture can be taken from the first two digits in the serial number.

CBX200 – WI-Manager Software

For installation in Zone 2 / Division 2 the following must be observed:

- The CBX200 is an interface cable for software.
- Configuration must be performed only in a safe area.

ATEX Certificate KEMA 10ATEX 0019 X

Marking



II 3 G Ex nA nC IIC / IIB / IIA T4
II (1) G [Ex ia] IIC / IIB / IIA
II (1) D [Ex iaD]

Standards EN 60079-0: 2006, EN 60079-11: 2007, EN 60079-15: 2005
EN 60079-26: 2007, EN 61241-0: 2006, EN 61241-11: 2006

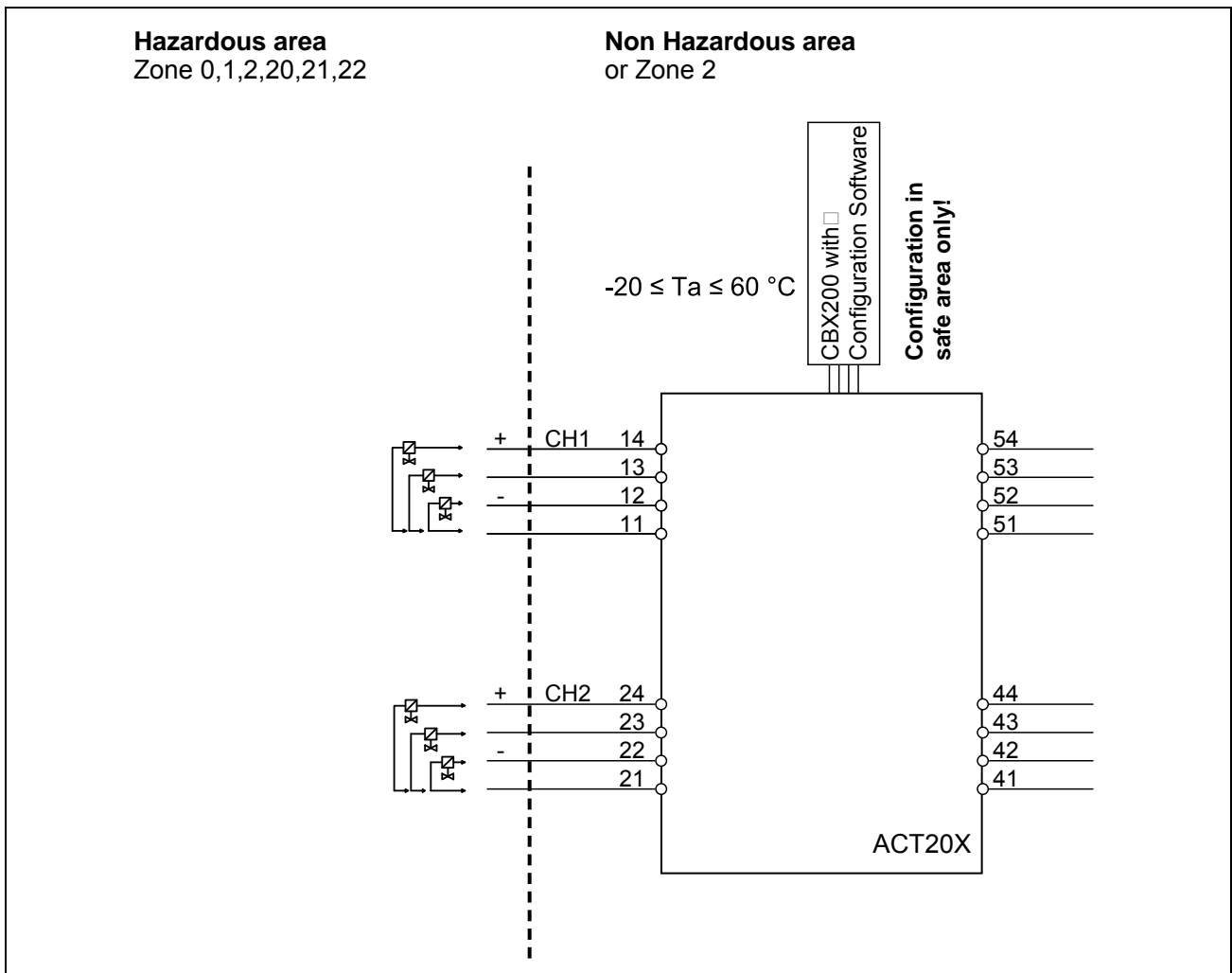

Illustration 7-25: ATEX Installation Drawing

Supply / Input

CH1 (terminal 41, 42, 43, 44)

CH2 (terminal 51, 52, 53, 54)

U_m : 253 V, max. 400 Hz

896540 (ACT20X-SDI-HDO-L-S), 896542 (ACT20X-2SDI-2HDO-S), Terminal 11–12 / 21–22			Co	Lo	Lo/Ro
Uo	28 V	IIC	80 nF	4.2 mH	54 $\mu\text{H}/\Omega$
Io	93 mA	IIB	640 nF	16.8 mH	218 $\mu\text{H}/\Omega$
Po	0.65 W	IIA	2.1 μF	32.6 mH	436 $\mu\text{H}/\Omega$

896540 (ACT20X-SDI-HDO-L-S), 896542 (ACT20X-2SDI-2HDO-S), Terminal 11–13 / 21–23			Co	Lo	Lo/Ro
Uo	28 V	IIC	80 nF	3.5 mH	50 $\mu\text{H}/\Omega$
Io	100 mA	IIB	640 nF	14.2 mH	201 $\mu\text{H}/\Omega$
Po	0.70 W	IIA	2.1 μF	27.6 mH	402 $\mu\text{H}/\Omega$

896540 (ACT20X-SDI-HDO-L-S), 896542 (ACT20X-2SDI-2HDO-S), Terminal 11–14 / 21–24			Co	Lo	Lo/Ro
Uo	28 V	IIC	80 nF	2.9 mH	46 $\mu\text{H}/\Omega$
Io	110 mA	IIB	640 nF	12.8 mH	184 $\mu\text{H}/\Omega$
Po	0.77 W	IIA	2.1 μF	22.8 mH	369 $\mu\text{H}/\Omega$

896541 (ACT20X-SDI-HDO-H-S), Terminal 11–12			Co	Lo	Lo/Ro
Uo	28 V	IIC	80 nF	2.69 mH	44 $\mu\text{H}/\Omega$
Io	115 mA	IIB	640 nF	10.8 mH	176 $\mu\text{H}/\Omega$
Po	0.81 W	IIA	2.1 μF	20.8 mH	353 $\mu\text{H}/\Omega$

896541 (ACT20X-SDI-HDO-H-S), Terminal 11–13			Co	Lo	Lo/Ro
Uo	28 V	IIC	–	–	–
Io	125 mA	IIB	640 nF	9.1 mH	162 $\mu\text{H}/\Omega$
Po	0.88 W	IIA	2.1 μF	17.6 mH	325 $\mu\text{H}/\Omega$

896541 (ACT20X-SDI-HDO-H-S), Terminal 11–14			Co	Lo	Lo/Ro
Uo	28 V	IIC	–	–	–
Io	135 mA	IIB	640 nF	7.8 mH	150 $\mu\text{H}/\Omega$
Po	0.95 W	IIA	2.1 μF	15.1 mH	301 $\mu\text{H}/\Omega$

Terminal (51, 52)

Supply:

Voltage 19.2...31.2 V DC

Power max. 3.5 W

Terminal CH1 (41, 42) CH2 (43, 44)

Input:

Voltage	Max 28 V DC
Trigger: NPN	Low < 2 V, High > 4 V
Trigger: PNP	Low < 8 V, High > 10 V

Terminal (53, 54)

Status Relay:	Non Hazardous location	Zone 2 installation
Voltage max.	125 V AC / 110 V DC	32 V AC / 32 V DC
Power max.	62.5 VA / 32 W	16 VA / 32 W
Current max.	0.5 A AC / 0.3 ADC	0.5 A AC / 1 ADC

Installation notes:

	DANGER
	To prevent ignition of explosive atmospheres, disconnect power before servicing and do not separate connectors when energized and an explosive gas mixture is present.

For installation in Zone 2, the module must be installed in an outer enclosure having an IP protection of at least IP54 according to type of protection Ex-n or Ex-e.

In type of protection "intrinsic safety iD" the parameters for intrinsic safety for gas group IIB are applicable.

If the sensor circuits (terminals 11–14, 21–22) have been installed in a type of protection other than "intrinsic safety", the module must not be re-installed in type of protection "intrinsic safety".

The maximum internal Power dissipation for adjacent modules is assumed to be max. 2 W each.

FM Installation drawing

ACT20X-SDI-HDO Solenoid / Alarm Driver

The module is available in the following variants:

Order No.	Installation Drawing No. IECEX	Type	Description
8965400000	4 51478 Bl. 5-6	ACT20X-SDI-HDO-L-S	solenoid / alarm driver, L = low current max. 35 mA
8965410000	4 51478 Bl. 5-6	ACT20X-SDI-HDO-H-S	solenoid / alarm driver, H = high current max. 60 mA
8965420000	4 51478 Bl. 5-6	ACT20X-2SDI-2HDO-S	2-channel solenoid / alarm driver, L = low current max. 35 mA

	DANGER
	For safe installation of ACT20X-SDI-HDO the following must be observed: The module may only be installed by qualified personnel familiar with the national and international laws, directives and standards that apply to this region.

The year of manufacture can be taken from the first two digits in the serial number.

CBX200 – WI-Manager Software

For installation in Zone 2 / Division 2 the following must be observed:

- The CBX200 is an interface cable for software.
- Configuration must be performed only in a safe area.

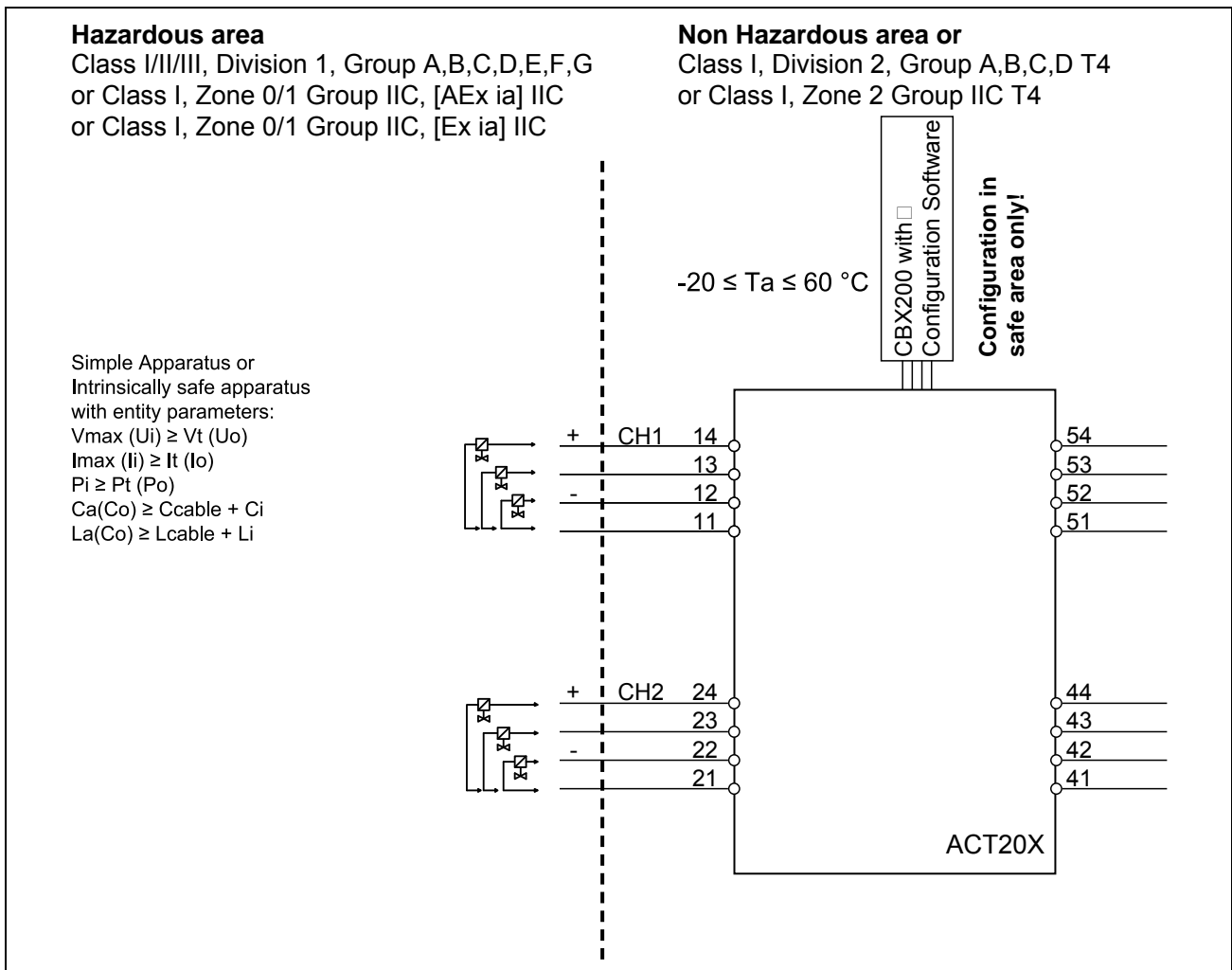

Illustration 7-26: FM Installation Drawing

Supply / Input

CH1 (terminal 41, 42, 43, 44)

CH2 (terminal 51, 52, 53, 54)

U_m : 253 V, max. 400 Hz

896540 (ACT20X-SDI-HDO-L-S), 896542 (ACT20X-2SDI-2HDO-S), Terminal 11–12 / 21–22			Co / Ca	Lo / La	Lo / Ro
U_o / V_T	28 V	IIC / A, B	80 nF	4.2 mH	54 $\mu\text{H}/\Omega$
I_o / I_{sc}	93 mA	IIB / C	640 nF	16.8 mH	218 $\mu\text{H}/\Omega$
P_o / P_t	0.65 W	IIA / D, E, F	2.1 μF	32.6 mH	436 $\mu\text{H}/\Omega$

896540 (ACT20X-SDI-HDO-L-S), 896542 (ACT20X-2SDI-2HDO-S), Terminal 11–13 / 21–23			Co / Ca	Lo / La	Lo / Ro
U _o / V _T	28 V	IIC / A, B	80 nF	3.5 mH	50 µH/Ω
I _o / I _{sc}	100 mA	IIB / C	640 nF	14.2 mH	203 µH/Ω
P _o / P _t	0.70 W	IIA / D, E, F	2.1 µF	27.6 mH	406 µH/Ω

896540 (ACT20X-SDI-HDO-L-S), 896542 (ACT20X-2SDI-2HDO-S), Terminal 11–14 / 21–24			Co / Ca	Lo / La	Lo / Ro
U _o / V _T	28 V	IIC / A, B	80 nF	2.9 mH	46 µH/Ω
I _o / I _{sc}	110 mA	IIB / C	640 nF	12.8 mH	184 µH/Ω
P _o / P _t	0.77 W	IIA / D, E, F	2.1 µF	22.8 mH	369 µH/Ω

896541 (ACT20X-SDI-HDO-H-S), Terminal 11–12			Co / Ca	Lo / La	Lo / Ro
U _o / V _T	28 V	IIC / A, B	80 nF	2.69 mH	44 µH/Ω
I _o / I _{sc}	115 mA	IIB / C	640 nF	10.8 mH	176 µH/Ω
P _o / P _t	0.81 W	IIA / D, E, F	2.1 µF	20.8 mH	353 µH/Ω

896541 (ACT20X-SDI-HDO-H-S), Terminal 11–13			Co / Ca	Lo / La	Lo / Ro
U _o / V _T	28 V	IIC / A, B	–	–	–
I _o / I _{sc}	125 mA	IIB / C	640 nF	9.1 mH	162 µH/Ω
P _o / P _t	0.88 W	IIA / D, E, F	2.1 µF	17.6 mH	325 µH/Ω

896541 (ACT20X-SDI-HDO-H-S), Terminal 11–14			Co / Ca	Lo / La	Lo / Ro
U _o / V _T	28 V	IIC / A, B	–	–	–
I _o / I _{sc}	135 mA	IIB / C	640 nF	7.8 mH	150 µH/Ω
P _o / P _t	0.95 W	IIA / D, E, F	2.1 µF	15.1 mH	301 µH/Ω

Terminal (51, 52)

Supply:

Voltage 19.2...31.2 V DC

Power max. 3.5 W

Terminal CH1 (41, 42) CH2 (43, 44)

Input:

Voltage Max 28 V DC
Trigger: NPN Low < 2 V, High > 4 V
Trigger: PNP Low < 8 V, High > 10 V

Terminal (53, 54)

Status Relay:	Non Hazardous location	Division 2 or Zone 2 installation
Voltage max.	125 V AC / 110 V DC	32 V AC / 32 V DC
Power max.	62.5 VA / 32 W	16 VA / 32 W
Current max.	0.5 A AC / 0.3 ADC	0.5 A AC / 1 ADC

Installation notes:

	DANGER
	To prevent ignition of explosive atmospheres, disconnect power before servicing and do not separate connectors when energized and an explosive gas mixture is present.

	WARNING
	Substitution of components may impair intrinsic safety and/or suitability for Div. 2/Zone 2.

The installation and wiring shall be in accordance with the Canadian Electrical Code for Canada and National Electrical Code NFPA 70, Article 500 or 505 for installation in USA.

The module must be supplied from a Power Supply having double or reinforced insulation.

The use of stranded wires is not permitted for mains wiring except when wires are fitted with cable ends.

The module must be installed in pollution degree 2 or better.

The module must be installed in an enclosure suitable for the environment where it is used.

For installation in Zone 2 or Division 2, the module must be installed in a suitable outer enclosure according to the regulations in the CEC for Canada or NEC for USA.

The module is galvanically isolated and does not require grounding.

Use 60/75 °C copper conductors in the wire size AWG: (26-14).

The maximum internal power dissipation for adjacent modules is assumed to be max. 2 W each.

Appendix D. Installation drawings ACT20X-HUI-SAO

IECEX Installation drawing

Universal Converter ACT20X-HUI-SAO

The module is available in the following variants:

Order No.	Installation Drawing No. IECEX	Type	Description
8965490000	451481 Bl. 5-9	ACT20X-HUI-SAO-S	Universal converter

	DANGER
	For safe installation of the Universal Converter ACT20X-HUI-SAO the following must be observed: The module may only be installed by qualified personnel familiar with the national and international laws, directives and standards that apply to this region.

The year of manufacture can be taken from the first two digits in the serial number.

CBX200 – WI-Manager Software

For installation in Zone 2 / Division 2 the following must be observed:

- The CBX200 is an interface cable for software.
- Configuration must be performed only in a safe area.

IECEX Certificate	IECEX KEM 10.0034 X
Marking	Ex nA nC IIC T4 Gc [Ex ia Ga] IIC / IIB / IIA [Ex ia Da] IIIC
Standards	IEC60079-15: 2005, IEC60079-11: 2006, IEC60079-0: 2007 IEC60079-26: 2006, IEC61241-0: 2004, IEC61241-11: 2005

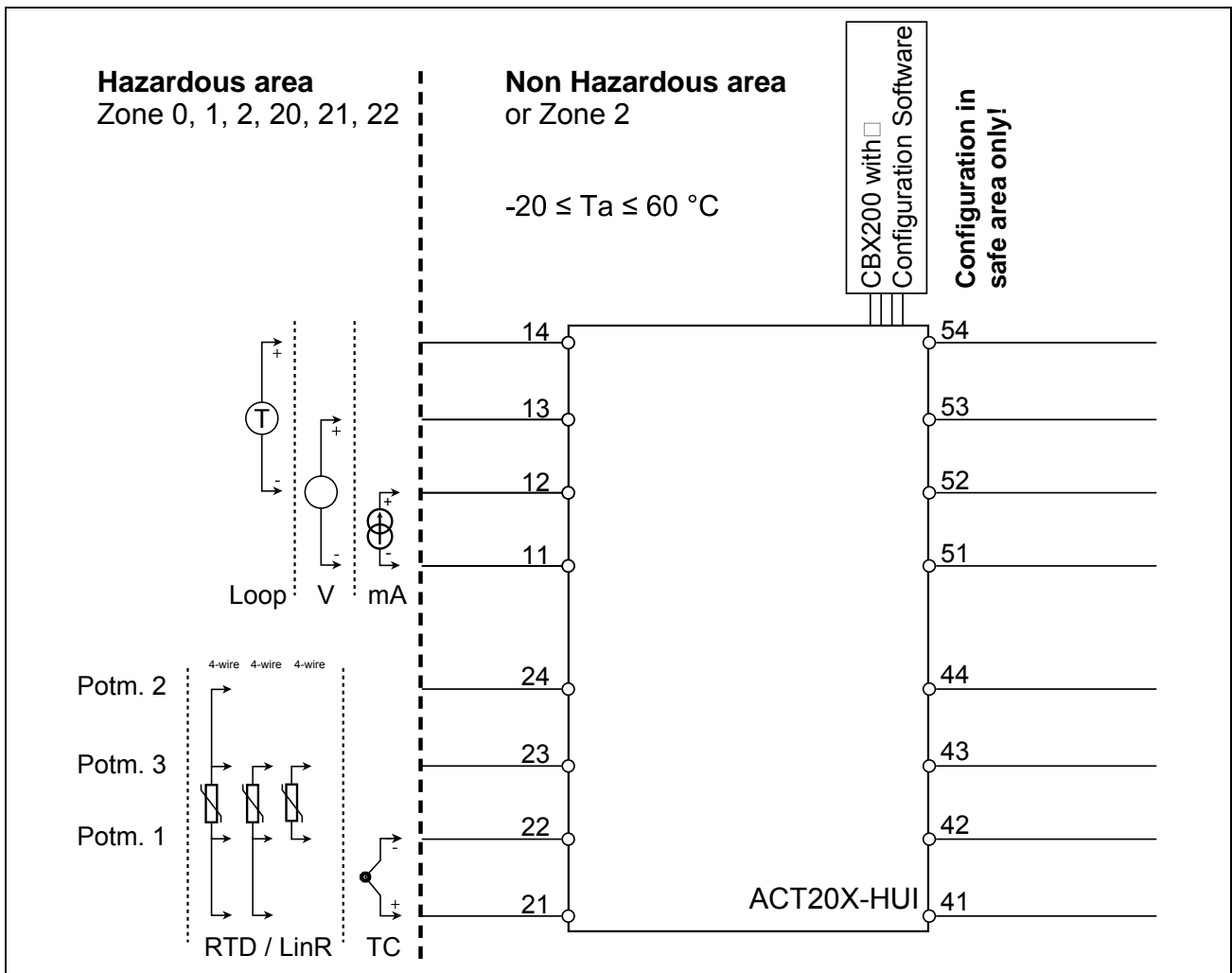

Illustration 7-27: IECEx Installation Drawing

Supply / Input

(terminal 41, 42, 43, 44)

(terminal 51, 52, 53, 54)

U_m : 253 V, max. 400 Hz

896549 (ACT20X-HUI-SAO), Terminal 21-24 / 22-			Co	Lo	Lo/Ro
Uo	28 V	IIC	80 nF	4.2 mH	54 μ H/ Ω
Io	93 mA	IIB	640 nF	16.8 mH	218 μ H/ Ω
Po	0.65 W	IIA	2.1 μ F	32.6 mH	436 μ H/ Ω

896549 (ACT20X-HUI-SAO), Terminal 21–23			Co	Lo	Lo/Ro
U _o	28 V	IIC	80 nF	100 mH	4 mH/Ω
I _o	1.1 mA	IIB	640 nF	100 mH	17 mH/Ω
P _o	0.80 W	IIA	2.1 μF	100 mH	35 mH/Ω

896549 (ACT20X-HUI-SAO), Terminal 21–22			Co	Lo	Lo/Ro
U _o	8.3 V	IIC	7 μF	100 mH	100 mH/Ω
I _o	0.2 mA	IIB	73 nF	100 mH	400 mH/Ω
P _o	0.4 W	IIA	1000 μF	100 mH	800 mH/Ω

896549 (ACT20X-HUI-SAO), Terminal 11, 12, 13, 14			Co	Lo	Lo/Ro
U _o	8.3 V	IIC	7 μF	100 mH	1 mH/Ω
I _o	13.1 mA	IIB	73 nF	100 mH	5 mH/Ω
P _o	27.3 mW	IIA	1000 μF	100 mH	10 mH/Ω

Terminal 21–22 / 21–23	
U _i :	30 V
I _i :	120 mA
P _i :	900 mW
C _i :	3 nF
L _i :	1 μF

Terminal (53, 54)

Status Relay:	Non Hazardous location	Zone 2 installation
Voltage max.	125 V AC / 110 V DC	32 V AC / 32 V DC
Power max.	62.5 VA / 32 W	16 VA / 32 W
Current max.	0.5 A AC / 0.3 A DC	0.5 A AC / 1 A DC

Terminal (43, 44)

Relay Output:	Non Hazardous location	Zone 2 installation
Voltage max.	250 V AC / 30 V DC	32 V AC / 30 V DC
Power max.	500 VA / 60 W	64 VA / 60 W
Current max.	2 A AC / 2 A DC	2 A AC / 2 A DC

Installation notes:

	<p>DANGER</p>
<p>To prevent ignition of explosive atmospheres, disconnect power before servicing and do not separate connectors when energized and an explosive gas mixture is present.</p>	

For installation in Zone 2, the module must be installed in an outer enclosure having an IP protection of at least IP54 conforming to the requirements of IEC60079-15.

In type of protection “intrinsic safety iD” the parameters for intrinsic safety for gas group IIB are applicable.

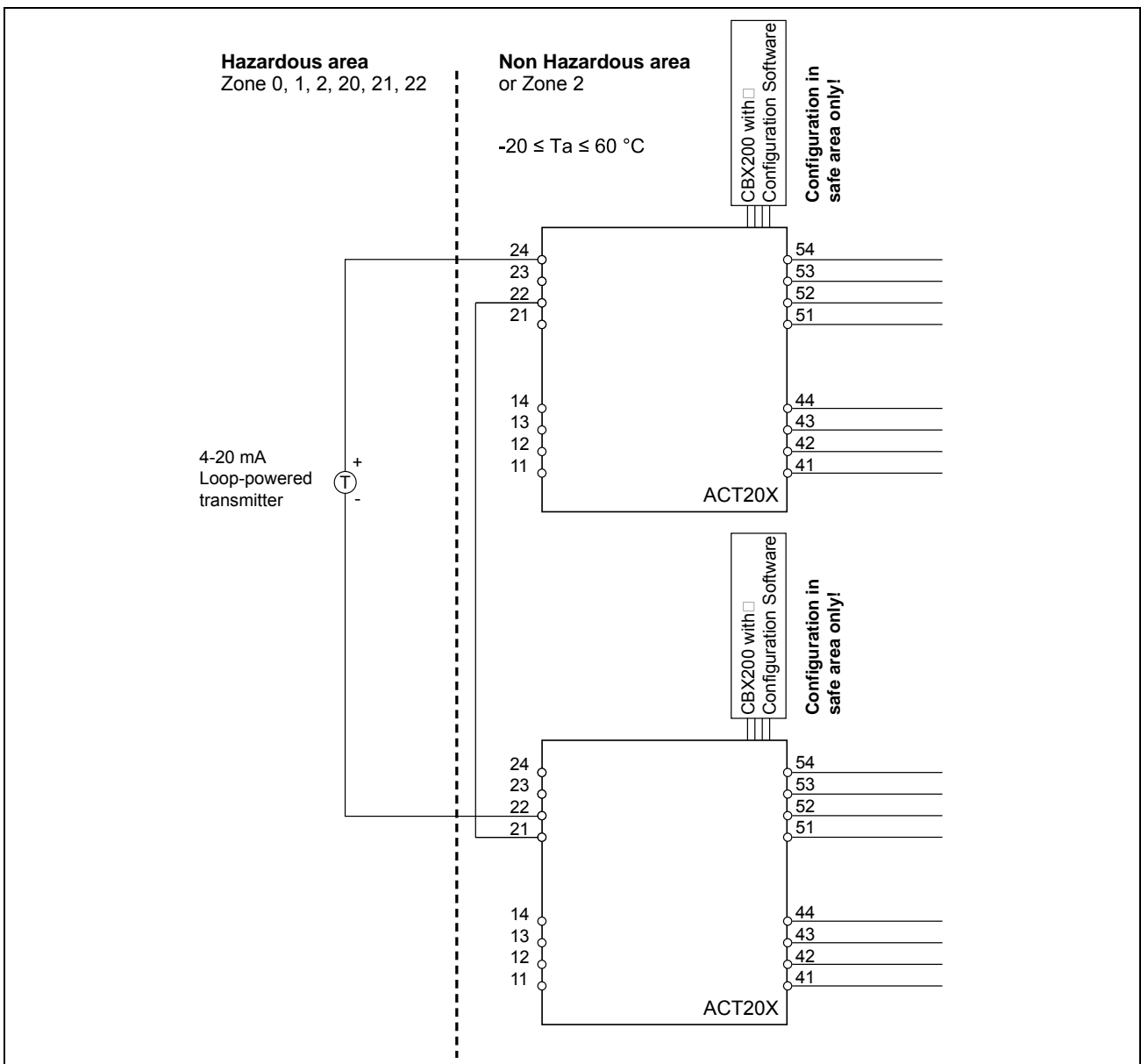

Illustration 7-28: IECEx Installation Drawing

Supply / Input

(terminal 41, 42, 43, 44)

(terminal 51, 52, 53, 54)

U_m : 253 V, max. 400 Hz

896549 (ACT20X-HUI-SAO), Terminal 24-12 / 21-22			Co	Lo	Lo/Ro
Uo	28 V	IIC	80 nF	4 mH	54 μ H/ Ω
Io	93 mA	IIB	640 nF	16 mH	218 μ H/ Ω
Po	650 mW	IIA	2.1 μ F	32 mH	436 μ H/ Ω

Terminal 21-22 / 21-23	
U _i :	30 V
I _i :	120 mA
P _i :	900 mW
C _i :	3 nF
L _i :	2 μ H

Terminal (53, 54)

Status Relay:	Non Hazardous location	Zone 2 installation
Voltage max.	125 V AC / 110 V DC	32 V AC / 32 V DC
Power max.	62.5 VA / 32 W	16 VA / 32 W
Current max.	0.5 A AC / 0.3 A DC	0.5 A AC / 1 A DC

Terminal (43, 44)

Relay Output:	Non Hazardous location	Zone 2 installation
Voltage max.	250 V AC / 30 V DC	32 V AC / 30 V DC
Power max.	500 VA / 60 W	64 VA / 60 W
Current max.	2 A AC / 2 A DC	2 A AC / 2 A DC

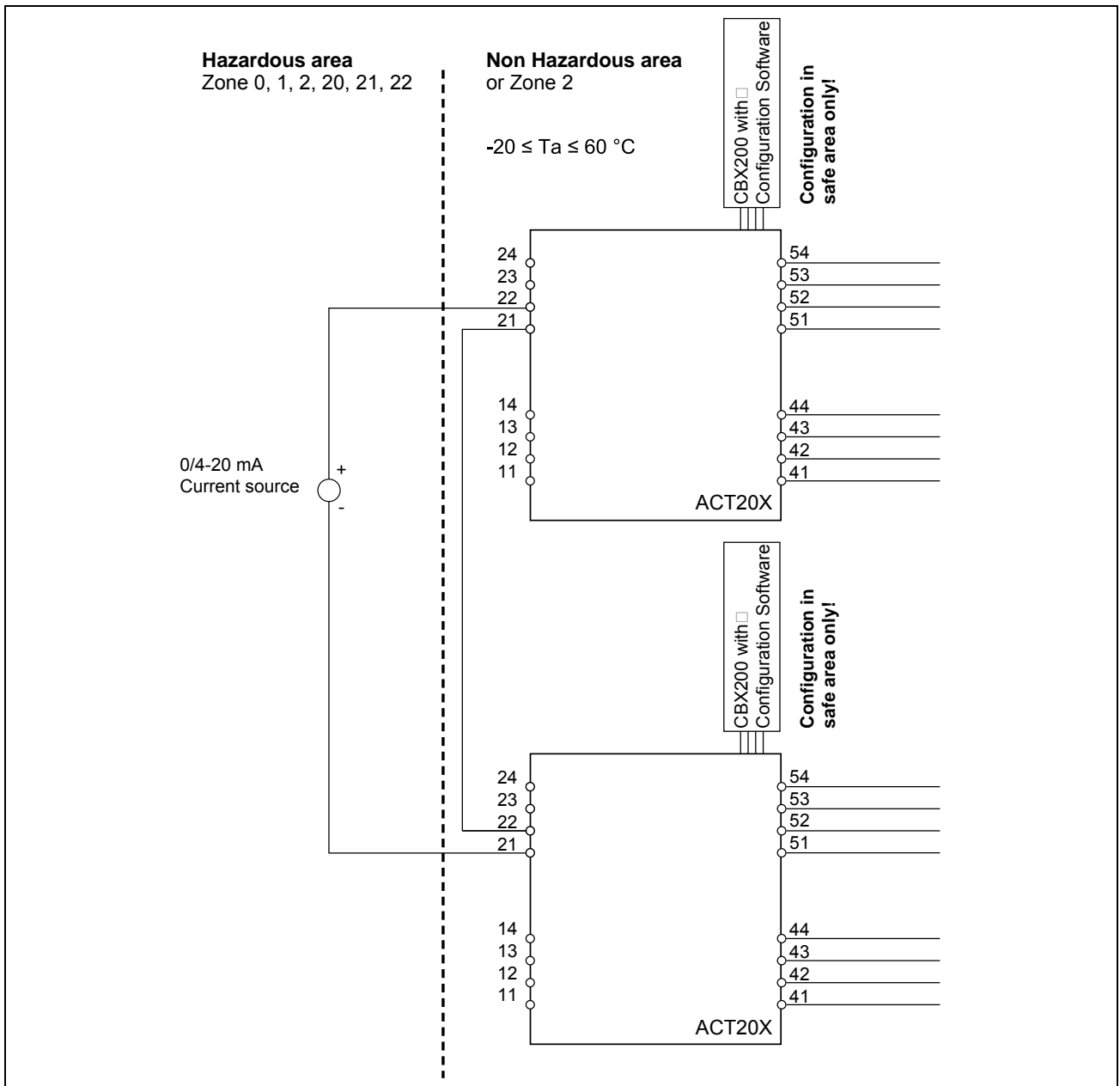

Illustration 7-29: IECEX Installation Drawing

Supply / Input

(terminal 41, 42, 43, 44)

(terminal 51, 52, 53, 54)

U_m : 253 V, max. 400 Hz

896549 (ACT20X-HUI-SAO), Terminal 14-12 / 21-22			Co	Lo	Lo/Ro
Uo	16.6 V	IIC	0.4 μF	100 mH	25 mH/ Ω
Io	0.2 mA	IIB	2.3 μF	100 mH	100 mH/ Ω
Po	0.8 mW	IIA	9.5 μF	100 mH	200 mH/ Ω

Terminal 21–22 / 21–23	
U _i :	30 V
I _i :	120 mA
P _i :	900 mW
C _i :	3 nF
L _i :	2 µH

Terminal (53, 54)

Status Relay:	Non Hazardous location	Zone 2 installation
Voltage max.	125 V AC / 110 V DC	32 V AC / 32 V DC
Power max.	62.5 VA / 32 W	16 VA / 32 W
Current max.	0.5 A AC / 0.3 A DC	0.5 A AC / 1 A DC

Terminal (43, 44)

Relay Output:	Non Hazardous location	Zone 2 installation
Voltage max.	250 V AC / 30 V DC	32 V AC / 30 V DC
Power max.	500 VA / 60 W	64 VA / 60 W
Current max.	2 A AC / 2 A DC	2 A AC / 2 A DC

ATEX Installation Drawing

Universal Converter ACT20X-HUI-SAO

The module is available in the following variants:

Order No.	Installation Drawing No. IECEX	Type	Description
8965490000	451481 Bl. 1-4	ACT20X-HUI-SAO-S	Universal converter



DANGER

For safe installation of the Universal Converter ACT20X-HUI-SAO the following must be observed: The module may only be installed by qualified personnel familiar with the national and international laws, directives and standards that apply to this region.

The year of manufacture can be taken from the first two digits in the serial number.

CBX200 – WI-Manager Software

For installation in Zone 2 / Division 2 the following must be observed:

- The CBX200 is an interface cable for software.
- Configuration must be performed only in a safe area.

ATEX Certificate KEMA 10ATEX 0071 X

Marking



II 3 G Ex nA nC IIC T4
II (1) G [Ex ia] IIC / IIB / IIA
II (1) D [Ex iaD]

Standards

IEC60079-0: 2006, IEC60079-11: 2007, IEC60079-15: 2005
IEC60079-26: 2007, IEC61241-0: 2006, IEC61241-11: 2006

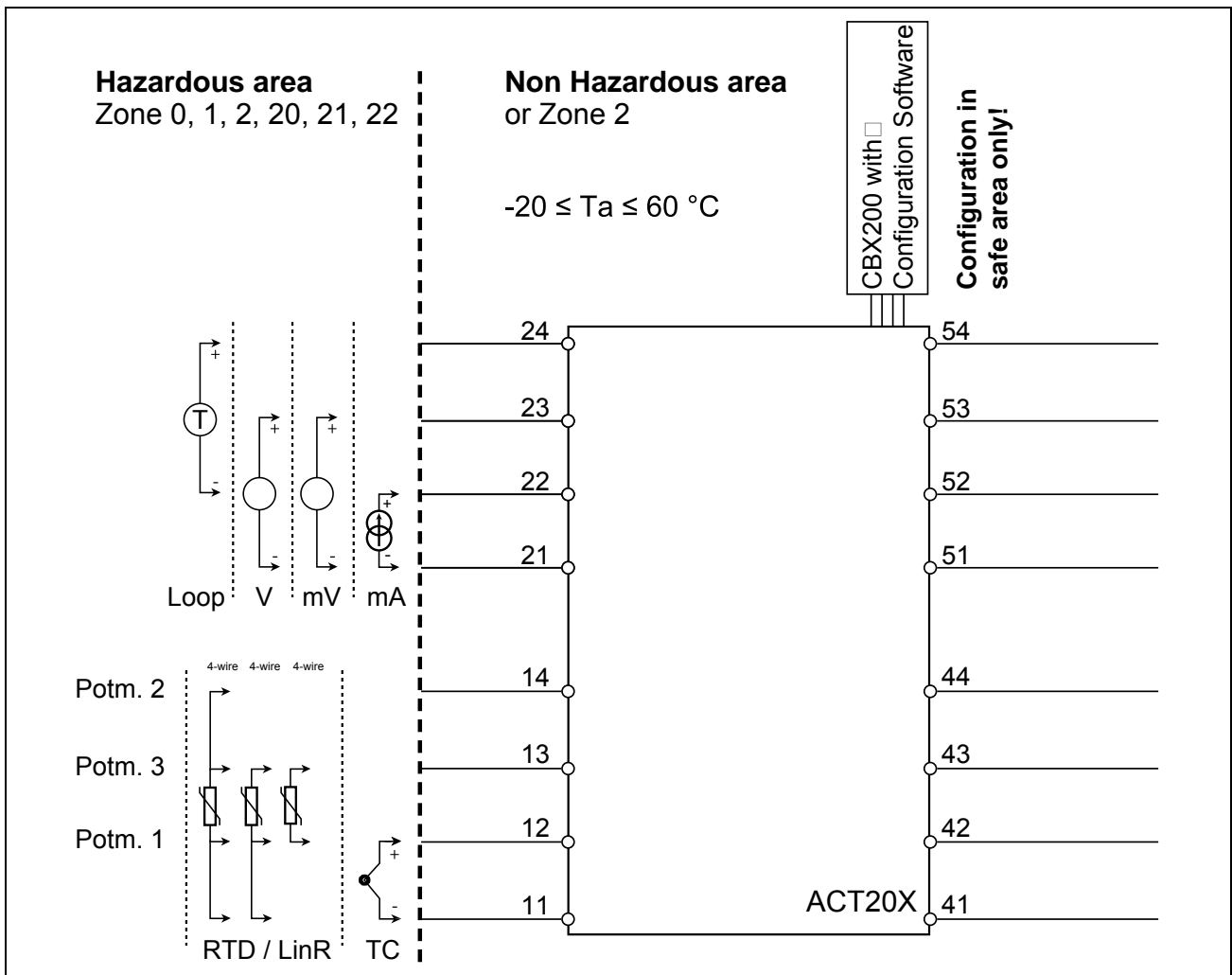

Illustration 7-30: ATEX Installation Drawing

Supply / Input

(terminal 41, 42, 43, 44)

(terminal 51, 52, 53, 54)

U_m : 253 V, max. 400 Hz

896549 (ACT20X-HUI-SAO), Terminal 21-24 / 22-			Co	Lo	Lo/Ro
Uo	28 V	IIC	80 nF	4 mH	54 $\mu\text{H}/\Omega$
Io	93 mA	IIB	640 nF	16 mH	218 $\mu\text{H}/\Omega$
Po	0.65 W	IIA	2.1 μF	32 mH	436 $\mu\text{H}/\Omega$

896549 (ACT20X-HUI-SAO), Terminal 21–23			Co	Lo	Lo/Ro
U _o	28 V	IIC	80 nF	100 mH	4 mH/Ω
I _o	1.1 mA	IIB	640 nF	100 mH	17 mH/Ω
P _o	8 mW	IIA	2.1 μF	100 mH	35 mH/Ω

896549 (ACT20X-HUI-SAO), Terminal 21-22			Co	Lo	Lo/Ro
U _o	8.3 V	IIC	7 μF	100 mH	10 mH/Ω
I _o	0.2 mA	IIB	73 μF	100 mH	40 mH/Ω
P _o	0.4 mW	IIA	1000 μF	100 mH	80 mH/Ω

896549 (ACT20X-HUI-SAO), Terminal 11, 12, 13, 14			Co	Lo	Lo/Ro
U _o	8.3 V	IIC	7 nF	100 mH	1 mH/Ω
I _o	13.1 mA	IIB	73 nF	100 mH	5 mH/Ω
P _o	27.3 mW	IIA	1000 μF	100 mH	10 mH/Ω

Terminal 21–22 / 21–23	
U _i :	30 V
I _i :	120 mA
P _i :	900 mW
C _i :	3 nF
L _i :	1 μH

Terminal (53, 54)

Status Relay:	Non Hazardous location	Zone 2 installation
Voltage max.	125 V AC / 110 V DC	32 V AC / 32 V DC
Power max.	62.5 VA / 32 W	16 VA / 32 W
Current max.	0.5 A AC / 0.3 A DC	0.5 A AC / 1 A DC

Terminal (43, 44)

Relay Output:	Non Hazardous location	Zone 2 installation
Voltage max.	250 V AC / 30 V DC	32 V AC / 30 V DC
Power max.	500 VA / 60 W	64 VA / 60 W
Current max.	2 A AC / 2 A DC	2 A AC / 2 A DC

Installation notes:

	<p>DANGER</p>
<p>To prevent ignition of explosive atmospheres, disconnect power before servicing and do not separate connectors when energized and an explosive gas mixture is present.</p>	

For installation in Zone 2, the module must be installed in an outer enclosure having an IP protection of at least IP54 conforming to the requirements of IEC60079-15.

In type of protection “intrinsic safety iD” the parameters for intrinsic safety for gas group IIB are applicable.

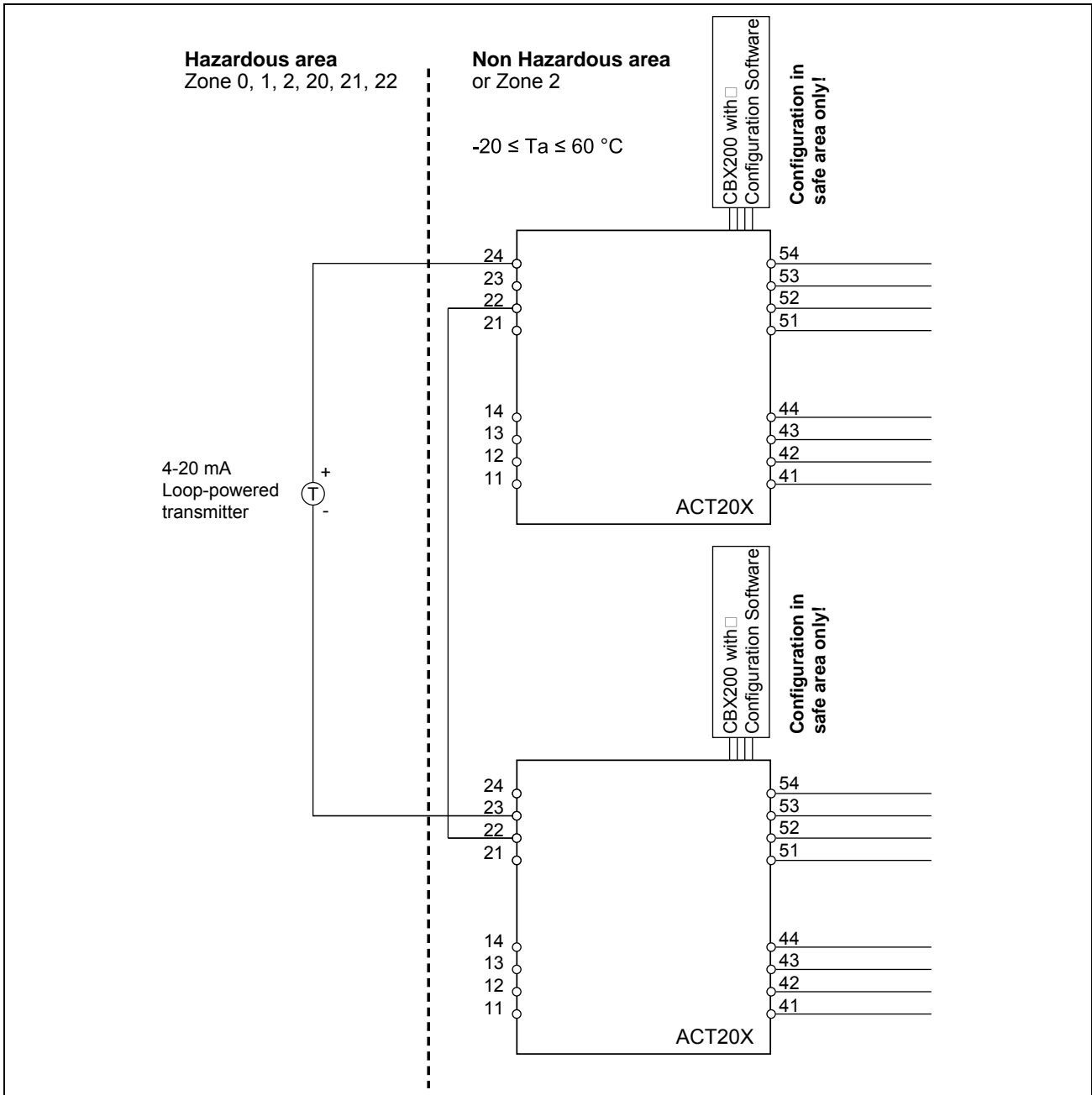

Illustration 7-31: ATEX Installation Drawing

Supply / Input

(terminal 41, 42, 43, 44)

(terminal 51, 52, 53, 54)

U_m : 253 V, max. 400 Hz

896549 (ACT20X-HUI-SAO), Modul A Terminal 24-22 / 21-22			Co	Lo	Lo/Ro
U _o	28 V	IIC	80 nF	4 mH	54 μH/Ω
I _o	93 mA	IIB	640 nF	16 mH	218 μH/Ω
P _o	650 mW	IIA	2.1 μF	32 mH	436 μH/Ω

Terminal 24–22	
U _i	30 V
I _i	120 mA
P _i	900 mW
C _i	3 nF
L _i	2 μH

Terminal (53, 54)

Status Relay:	Non Hazardous location	Zone 2 installation
Voltage max.	125 V AC / 110 V DC	32 V AC / 32 V DC
Power max.	62.5 VA / 32 W	16 VA / 32 W
Current max.	0.5 A AC / 0.3 A DC	0.5 A AC / 1 A DC

Terminal (43, 44)

Relay Output:	Non Hazardous location	Zone 2 installation
Voltage max.	250 V AC / 30 V DC	32 V AC / 30 V DC
Power max.	500 VA / 60 W	64 VA / 60 W
Current max.	2 A AC / 2 A DC	2 A AC / 2 A DC

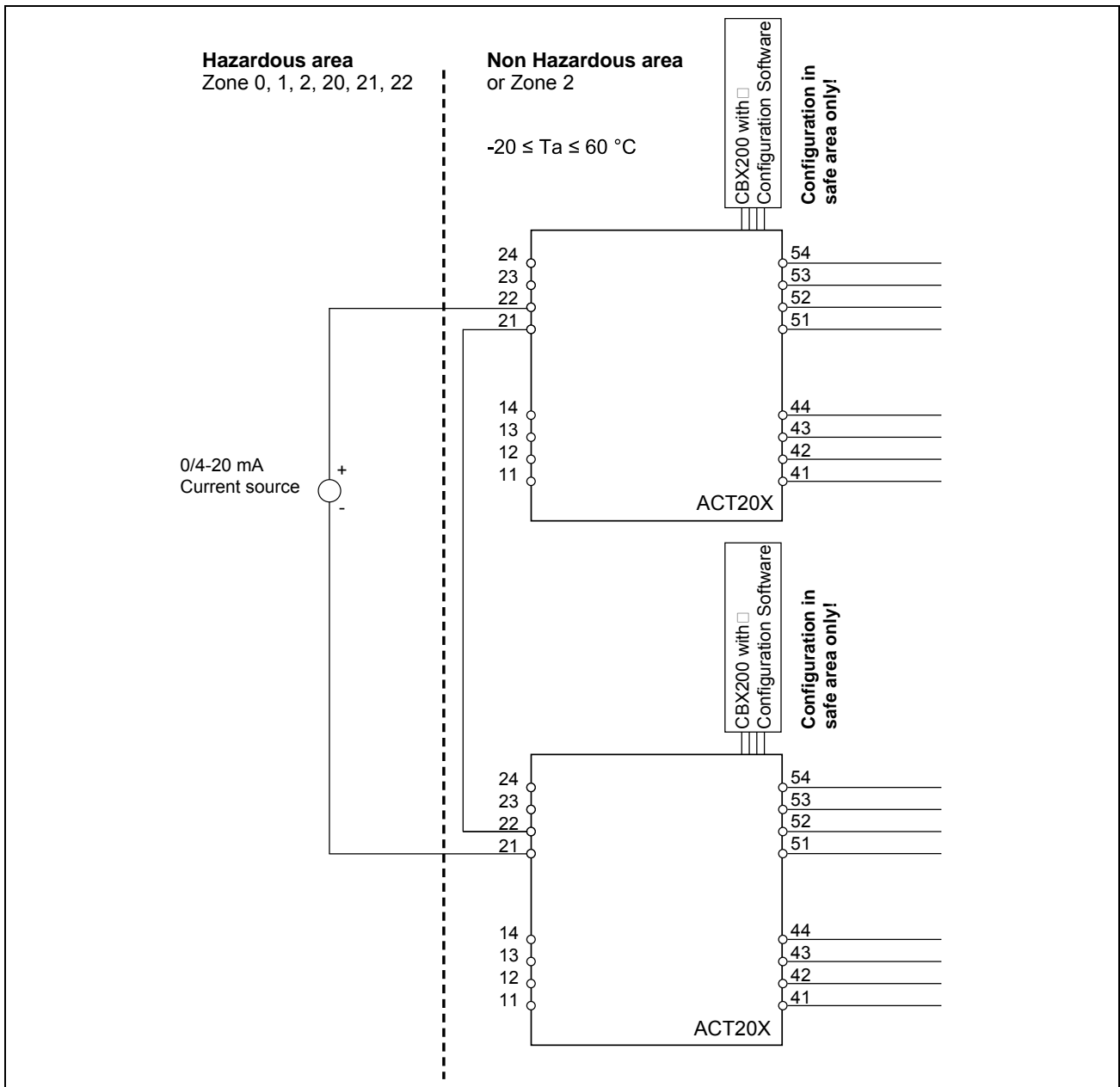

Illustration 7-32: ATEX Installation Drawing

Supply / Input

(terminal 41, 42, 43, 44)

(terminal 51, 52, 53, 54)

U_m : 253 V, max. 400 Hz

896549 (ACT20X-HUI-SAO), Terminal 21-24 / 22-			Co	Lo	Lo/Ro
Uo	16.6 V	IIC	0.4 μF	100 mH	25 mH/ Ω
Io	0.2 mA	IIB	2.3 μF	100 mH	100 mH/ Ω
Po	0.8 mW	IIA	9.5 μF	100 mH	200 mH/ Ω

Terminal 21–22	
U _i :	30 V
I _i :	120 mA
P _i :	900 mW
C _i :	3 nF
L _i :	2 μH

Terminal (53, 54)

Status Relay:	Non Hazardous location	Zone 2 installation
Voltage max.	125 V AC / 110 V DC	32 V AC / 32 V DC
Power max.	62.5 VA / 32 W	16 VA / 32 W
Current max.	0.5 A AC / 0.3 A DC	0.5 A AC / 1 A DC

Terminal (43, 44)

Relay Output:	Non Hazardous location	Zone 2 installation
Voltage max.	250 V AC / 30 V DC	32 V AC / 30 V DC
Power max.	500 VA / 60 W	64 VA / 60 W
Current max.	2 A AC / 2 A DC	2 A AC / 2 A DC

FM Installation drawing

Universal Converter ACT20X-HUI-SAO

The module is available in the following variants:

Order No.	Installation Drawing No. IECEX	Type	Description
8965490000	451481 Bl. 9-12	ACT20X-HUI-SAO-S	Universal converter

	DANGER
	For safe installation of the Universal Converter ACT20X-HUI-SAO the following must be observed: The module may only be installed by qualified personnel familiar with the national and international laws, directives and standards that apply to this region.

The year of manufacture can be taken from the first two digits in the serial number.

CBX200 – WI-Manager Software

For installation in Zone 2 / Division 2 the following must be observed:

- The CBX200 is an interface cable for software.
- Configuration must be performed only in a safe area.

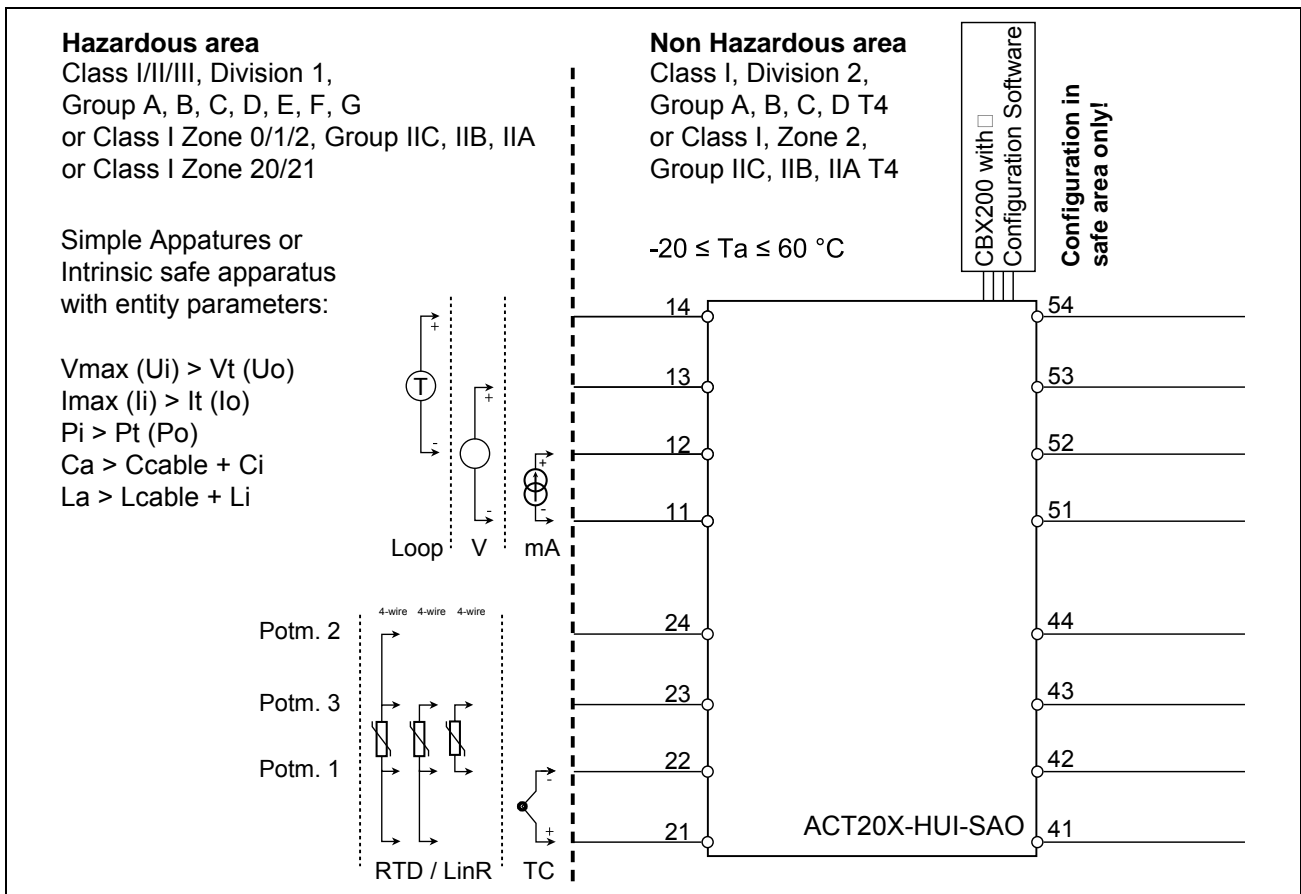

Illustration 7-33: FM Installation Drawing

Supply / Input

(terminal 41, 42, 43, 44)

(terminal 51, 52, 53, 54)

U_m : 253 V, max. 400 Hz

896549 (ACT20X-HUI-SAO), Terminal 21-24 / 22-24			Co	Lo	Lo/Ro
U_o, V_{oc}	28 V	IIC or A, B	80 nF	4.2 mH	54 $\mu\text{H}/\Omega$
I_o, I_{sc}	93 mA	IIB or C, E, F	640 nF	16.8 mH	218 $\mu\text{H}/\Omega$
P_o	0.65 W	IIA or D, G	2.1 μF	32.6 mH	436 $\mu\text{H}/\Omega$

896549 (ACT20X-HUI-SAO), Terminal 21-23			Co	Lo	Lo/Ro
U_o, V_{oc}	28 V	IIC or A, B	80 nF	100 mH	4 mH/ Ω
I_o, I_{sc}	1.1 mA	IIB or C, E, F	640 nF	100 mH	17 mH/ Ω
P_o	8 mW	IIA or D, G	2.1 μF	100 mH	35 mH/ Ω

896549 (ACT20X-HUI-SAO), Terminal 21-22			Co	Lo	Lo/Ro
U _o , Voc	8.3 V	IIC or A, B	7 µF	100 mH	10 mH/Ω
I _o , I _{sc}	0.2 mA	IIB or C, E, F	73 µF	100 mH	40 mH/Ω
P _o	0.4 mW	IIA or D, G	1000 µF	100 mH	80 mH/Ω

896549 (ACT20X-HUI-SAO), Terminal 11, 12, 13, 14			Co	Lo	Lo/Ro
U _o , Voc	8.3 V	IIC or A, B	7 µF	100 mH	1 mH/Ω
I _o , I _{sc}	13.1 mA	IIB or C, E, F	73 µF	100 mH	5 mH/Ω
P _o	27.3 mW	IIA or D, G	1000 µF	100 mH	10 mH/Ω

Terminal 21–22 / 21–23	
U _i :	30 V
I _i :	120 mA
P _i :	900 mW
C _i :	3 nF
L _i :	1 µH

Terminal (53, 54)

Status Relay:	Non Hazardous location	Zone 2 installation
Voltage max.	125 V AC / 110 V DC	32 V AC / 32 V DC
Power max.	62.5 VA / 32 W	16 VA / 32 W
Current max.	0.5 A AC / 0.3 A DC	0.5 A AC / 1 A DC

Terminal (43, 44)

Relay Output:	Non Hazardous location	Zone 2 installation
Voltage max.	250 V AC / 30 V DC	32 V AC / 30 V DC
Power max.	500 VA / 60 W	64 VA / 60 W
Current max.	2 A AC / 2 A DC	2 A AC / 2 A DC

Installation notes:

	DANGER
	To prevent ignition of explosive atmospheres, disconnect power before servicing and do not separate connectors when energized and an explosive gas mixture is present.

	WARNING
	Substitution of components may impair intrinsic safety and/or suitability for Div. 2 / Zone 2.

The installation and wiring must be in accordance with the Canadian Electrical Code for Canada and National Electrical Code NFPA 70, Article 500 or 505 for installation in USA.

For installation in Zone 2 or Division 2, the module must be installed in a suitable outer enclosure having an IP protection of at least IP54.

The module is galvanically isolated and does not require grounding.

The module must be installed in pollution degree 2 or better.

In type of protection "intrinsic safety iD" the parameters for intrinsic safety for gas group II B are applicable.

Use 60/75 °C copper conductors in the wire size AWG: (26-14).

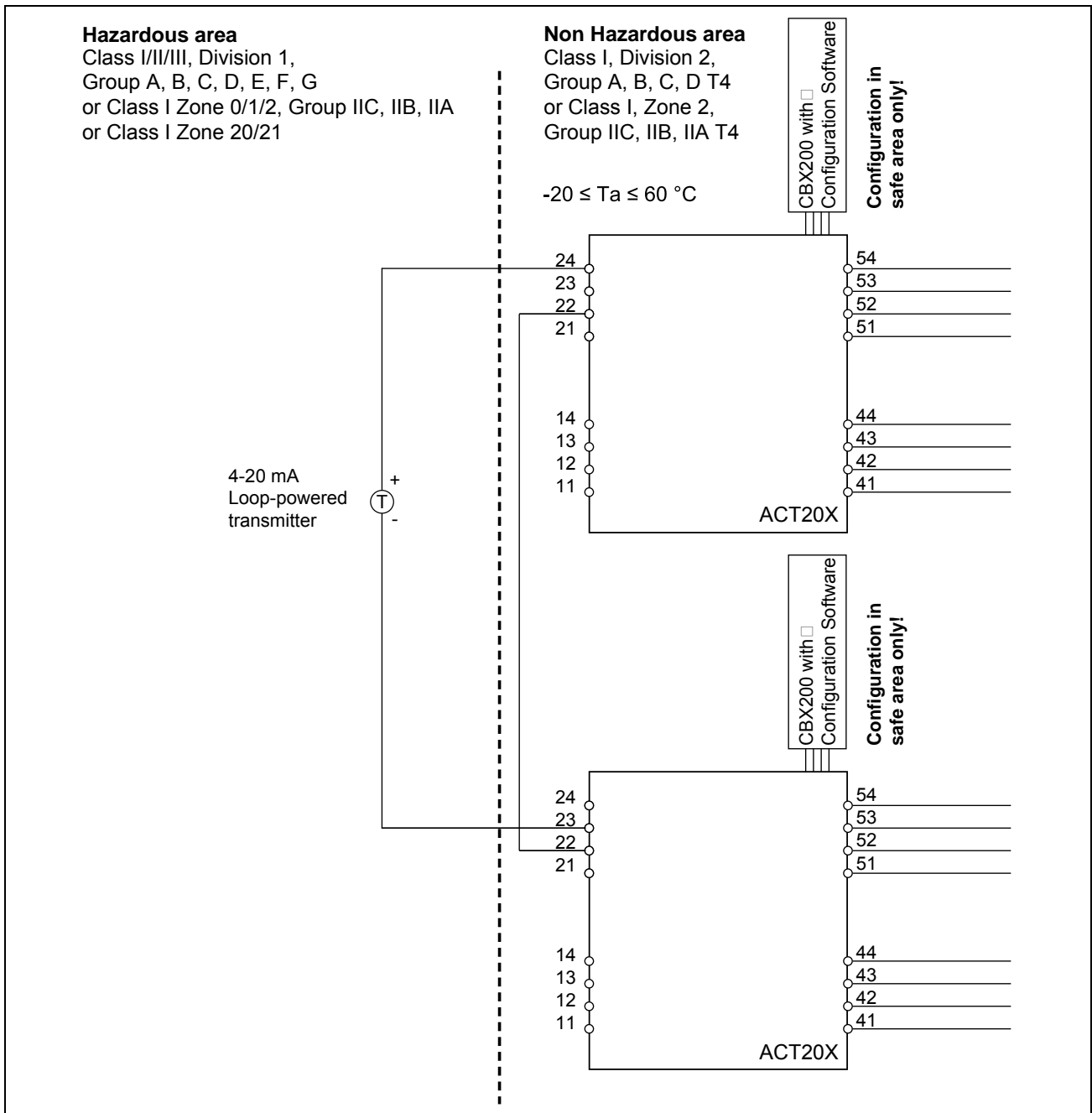

Illustration 7-34: FM Installation Drawing

Supply / Input

(terminal 41, 42, 43, 44)

(terminal 51, 52, 53, 54)

U_m : 253 V, max. 400 Hz

896549 (ACT20X-HUI-SAO), Terminal 24–22 / 21–22			Co	Lo	Lo/Ro
U _o , Voc	28 V	IIC or A, B	80 nF	4.2 mH	54 μH/Ω
I _o , Isc	93 mA	IIB or C, E, F	640 nF	16.8 mH	218 μH/Ω
P _o	0.65 W	IIA or D, G	2.1 μF	32.6 mH	436 μH/Ω

Terminal 24–22	
U _i :	30 V
I _i :	120 mA
P _i :	900 mW
C _i :	3 nF
L _i :	2 μH

Terminal (21, 22, 23)

U_i, V_{max}: 30 V

I_i, I_{max}: 120 mA

P_i: 900 mW

C_i: 3 nF

L_i: 2 μH

Terminal (53, 54)

Status Relay:	Non Hazardous location	Zone 2 installation
Voltage max.	125 V AC / 110 V DC	32 V AC / 32 V DC
Power max.	62.5 VA / 32 W	16 VA / 32 W
Current max.	0.5 A AC / 0.3 A DC	0.5 A AC / 1 A DC

Terminal (43, 44)

Relay Output:	Non Hazardous location	Zone 2 installation
Voltage max.	250 V AC / 30 V DC	32 V AC / 30 V DC
Power max.	500 VA / 60 W	64 VA / 60 W
Current max.	2 A AC / 2 A DC	2 A AC / 2 A DC

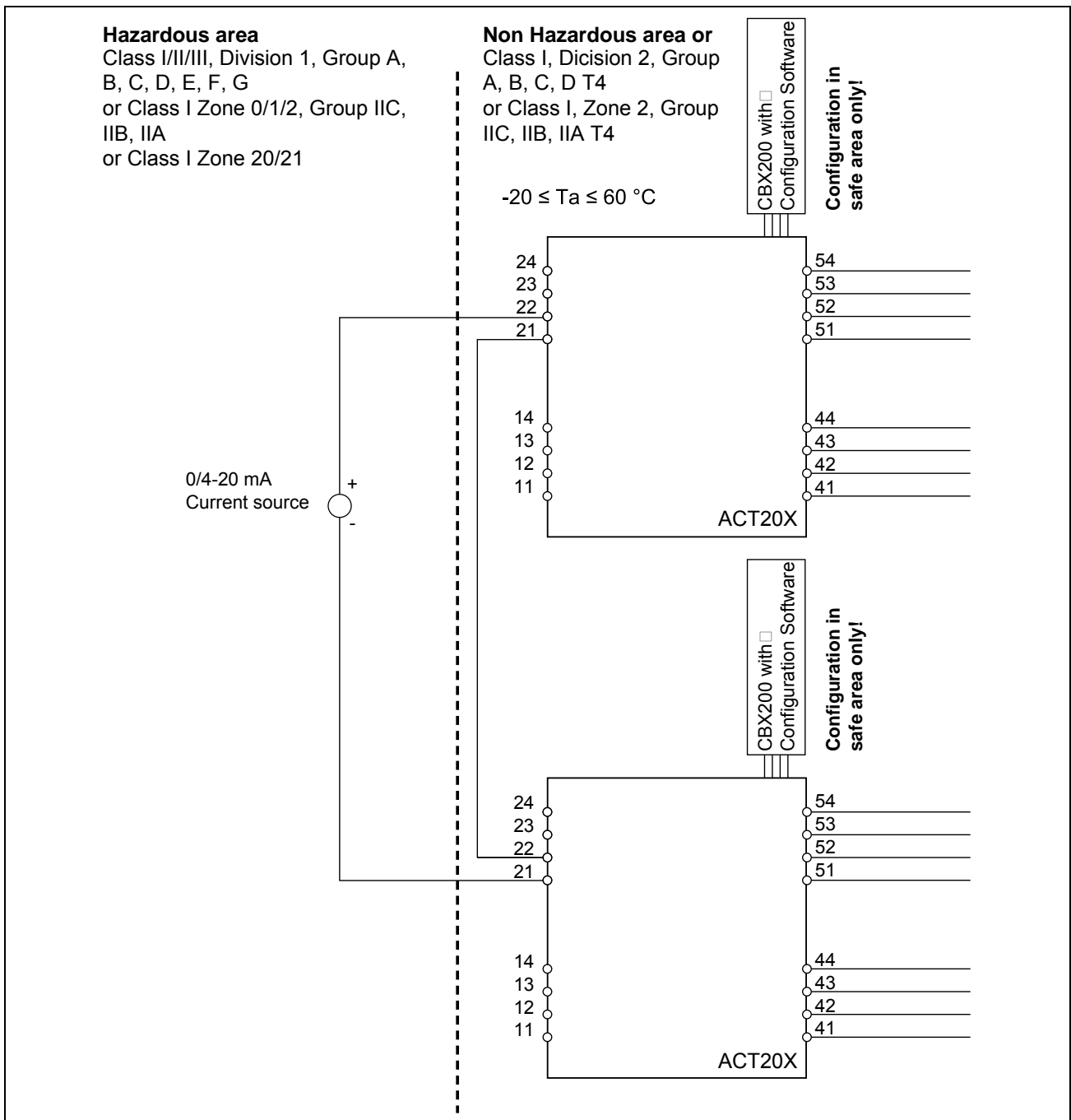

Illustration 7-35: FM Installation Drawing

Supply / Input

(terminal 41, 42, 43, 44)

(terminal 51, 52, 53, 54)

U_m : 253 V, max. 400 Hz

896549 (ACT20X-HUI-SAO), Terminal 22-21,21-22			Co	Lo	Lo/Ro
U _o , Voc	16.6 V	IIC or A, B	0.4 µF	1000 mH	25 mH/Ω
I _o , I _{sc}	0.2 mA	IIB or C, E, F	2.3 µF	1000 mH	100 mH/Ω
P _o	0.8 mW	IIA or D, G	9.5 µF	1000 mH	200 mH/Ω

Terminal 21–22	
U _i :	30 V
I _i :	120 mA
P _i :	900 mW
C _i :	3 nF
L _i :	2 µH

Terminal (21, 22, 23)

U_i, V_{max}: 30 V

I_i, I_{max}: 120 mA

P_i: 900 mW

C_i: 3 nF

L_i: 2 µH

Terminal (53, 54)

Status Relay:	Non Hazardous location	Zone 2 installation
Voltage max.	125 V AC / 110 V DC	32 V AC / 32 V DC
Power max.	62.5 VA / 32 W	16 VA / 32 W
Current max.	0.5 A AC / 0.3 A DC	0.5 A AC / 1 A DC

Terminal (43, 44)

Relay Output:	Non Hazardous location	Zone 2 installation
Voltage max.	250 V AC / 30 V DC	32 V AC / 30 V DC
Power max.	500 VA / 60 W	64 VA / 60 W
Current max.	2 A AC / 2 A DC	2 A AC / 2 A DC

www.weidmueller.com

Weidmüller Interface GmbH & Co. KG

P.O. Box 3030

D-32720 Detmold

Klingenbergstraße 16

D-32758 Detmold

Phone +49 (0) 5231 14-0

Fax +49 (0) 5231 14-2083

E-Mail info@weidmuller.com

Internet www.weidmueller.com

Order number:

1066540000/00/02.09