

---

**User's  
Manual**

**ASGW  
Analyzer Server Gateway  
Software**

**GC8000**  
GC10000 *Mark II*

IM 11B06E01-01E

---

**vigilantplant.®**

---

# Introduction

Thank you for purchasing the ASGW Analyzer Server Gateway Software.

ASGW Analyzer Server Gateway is the software to communicate between DCS and the multiple GC8000 or GC1000 MarkII which connected in ANABUS Network.

This manual describes the basic method of operating the ASGW.

For how to operate GC8000 or GC1000 MarkII, refer to their corresponding user's manuals.

## ● **Applicable Readers**

The description of the installation method assumes that the reader has a basic knowledge of hardware and software that is necessary for installing the ASGW, and Windows as well.

For further details of Windows, refer to the respective manuals.

## ● **Contents of the Package**

The contents of the package are as follows. Check the contents of your package.

- ASGW installation disc
- ASGW User's Manual (this manual)

---

# Safety Precautions

- In order to protect the system controlled by the product and the product itself and ensure safe operation, observe the safety precautions described in this user's manual. We assume no liability for safety if users fail to observe these instructions when operating the product.
- Modification of the product is strictly prohibited.

## ■ Notes on Handling User's Manuals

- Please hand over the user's manuals to your end users so that they can keep the user's manuals on hand for convenient reference.
- Please read the information thoroughly before using the product.
- The purpose of these user's manuals is not to warrant that the product is well suited to any particular purpose but rather to describe the functional details of the product.
- No part of the user's manuals may be transferred or reproduced without prior written consent from YOKOGAWA.
- YOKOGAWA reserves the right to make improvements in the user's manuals and product at any time, without notice or obligation.
- If you have any questions, or you find mistakes or omissions in the user's manuals, please contact our sales representative or your local distributor.

## ■ Warning and Disclaimer

The product is provided on an "as is" basis. YOKOGAWA shall have neither liability nor responsibility to any person or entity with respect to any direct or indirect loss or damage arising from using the product or any defect of the product that YOKOGAWA can not predict in advance.

## ■ Notes on Software

- YOKOGAWA makes no warranties, either expressed or implied, with respect to the software's merchantability or suitability for any particular purpose, except as specified in the terms of warranty.
- It is strictly prohibited to reproduce the product except for the purpose of backup.
- Store the CD-ROM (the original medium) in a safe place.
- It is strictly prohibited to perform any reverse-engineering operation, such as reverse compilation or reverse assembling on the product.
- No part of the product may be transferred, converted or sublet for use by any third party, without prior written consent from YOKOGAWA.

---

# Documentation Conventions

## ■ Symbol Marks

Throughout this user's manual, you will find several different types of symbols are used to identify different sections of text. This section describes these icons.



### **NOTE**

Identifies important information required to understand operations or functions.



### **TIP**

Identifies additional information.



### **SEE ALSO**

Identifies a source to be referred to.

**HELP !**

Indicates text describing the action to be taken when a message or indication is displayed during an operation.

## ■ Keyboard Inscriptions

Keyboard operations are indicated in this manual as shown in the following example.

(Inscription example)

[Shift] + [F1]

(Meaning)

Indicates that the operator must press the [F1] key while pressing the [Shift] key.

## ■ Menu Inscriptions

Menu operations are indicated in this manual as shown in the following example.

(Inscription example)

Click on [Connect] in the [System] menu.

(Meaning)

Click on the [System] menu, then click on the [Connect] command.

## ■ Drawing Conventions

Some drawings may be partially emphasized, simplified, or omitted, for the convenience of description.

Some screen images depicted in the user's manual may have different display positions or character types (e.g., the upper / lower case). Also note that some of the images contained in this user's manual are display examples.

---

# Copyright and Trademark Notices

## ■ All Rights Reserved

The copyrights of the programs and on-line manual contained in the CD-ROM are reserved.

The on-line manual is protected by the PDF security from modification, however, it can be output via a printer. Printing out the on-line manual is only allowed for the purpose of using the product. When using the printed information of the on-line manual, check if the version is the most recent one by referring to the CD-ROM's version.

No part of the on-line manual may be transferred, sold, distributed (including delivery via a commercial PC network or the like), or registered or recorded on video tapes.

## ■ Trademark Acknowledgments

- Microsoft, Windows and Windows NT are either registered trademarks or trademarks of Microsoft Corporation in the United States and/or other countries.
- Ethernet is a registered trademark of XEROX Corporation.
- Java is a registered trademark of Sun Microsystems, Inc.
- Modbus is a registered trademark of Schneider Electric SA.
- All other company and product names mentioned in this user's manual are trademarks or registered trademarks of their respective companies.
- We do not use TM or ® mark to indicate those trademarks or registered trademarks in this user's manual.

# ASGW

## Analyzer Server Gateway

### Software

IM 11B06E01-01E 4th Edition

## CONTENTS

Introduction .....	i
Safety Precautions .....	ii
Documentation Conventions .....	iii
Copyright and Trademark Notices .....	iv
<b>1. Outline .....</b>	<b>1-1</b>
<b>2. Configuration .....</b>	<b>2-1</b>
2.1 Hardware configuration .....	2-1
2.2 Software configuration .....	2-1
<b>3. Functions .....</b>	<b>3-1</b>
3.1 Interface to DCS .....	3-1
3.2 Address mapping .....	3-1
3.3 Alarm information .....	3-2
3.4 Modbus interface table .....	3-2
<b>4. Engineering .....</b>	<b>4-1</b>
4.1 Installation .....	4-1
4.1.1 Preparation .....	4-1
4.1.2 Initial setting .....	4-1
4.2 Data mapping .....	4-4
4.2.1 Preparation .....	4-4
4.2.2 Loading a mapping file .....	4-5
4.2.3 Setting .....	4-6
4.2.4 Transfer to ASGW .....	4-8
4.2.5 Diagnosis information .....	4-8
4.2.6 Transferring the mapping file by means other than Internet Explorer .....	4-8
4.3 Additional Information .....	4-10
4.3.1 Modification of IP addressing setting .....	4-10
4.3.2 Modification of serial port setting .....	4-14
4.3.3 Allocating DO information .....	4-14
<b>5. Diagnostic Window .....</b>	<b>5-1</b>
5.1 Start-up of the diagnostic window .....	5-1
5.2 Data transfer of the mapping file and error diagnostic .....	5-2
5.3 Checking the analyzer communication status and displaying the mapping data .....	5-4

---

5.4	Maintenance of FCJ .....	5-6
<b>6.</b>	<b>OPC DA 2.0 Interface.....</b>	<b>6-1</b>
6.1	System Configuration .....	6-1
6.2	Software Required .....	6-1
6.3	Installation and Settings .....	6-1
6.4	Update rate .....	6-1
6.5	List of OPC Data Names .....	6-2
<b>7.</b>	<b>ARCNET.....</b>	<b>7-1</b>
<b>8.</b>	<b>Troubleshooting .....</b>	<b>8-1</b>
8.1	Install .....	8-1
8.2	Diagnostic window (Web browser).....	8-1
	<b>Revision Information .....</b>	<b>i</b>

# 1. Outline

ASGW is software which serves as a gateway in the Ethernet analyzer bus system to enhance communication between the GC8000, GC1000 MarkII or ASIU (hereafter called "analyzer") and DCS. FCJ is used as its hardware component.

ASGW controls the Modbus protocol communication between multiple analyzers and DCS and improves engineering efficiency and communication performance.

ASGW has two type interfaces: Modbus TCP Ethernet one port and Modbus RTU serial.

Modbus mapping is realized with address table and programming is not necessary.

FCJ is described as ASGW is in this document.

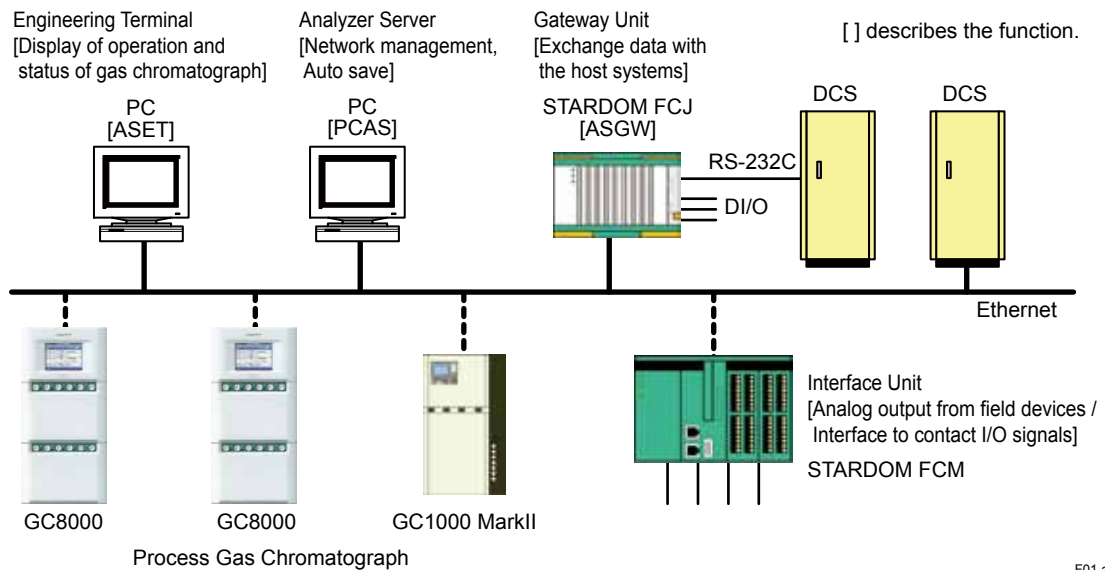

F01.ai

Figure 1.1 Conceptual Diagram of the Ethernet Analyzer Bus System



# 2. Configuration

This chapter explains the configuration of the hardware and software of STARDOM FCJ required for ASGW.

Refer to the General Specifications of STARDOM for details of each item.

## 2.1 Hardware configuration

The following type FCJ is required for the ASGW.

Model Name	Item	Remarks
NFJT100-S10□	FCJ	

## 2.2 Software configuration

ASGW

Model	Suffix Code	Option Code	Description
<b>ASGW</b>	.....	.....	Software Package
Function	<b>-A01</b>	.....	Standard
Language	<b>E</b>	.....	English
	<b>J</b>	.....	Japanese
—	<b>-N</b>	.....	Always "-N"
—	<b>N</b>	.....	Always "N"

ASGW requires the license and software shown below.

License Code	Item	Remarks
NT711AJ-LM05E	FCN/FCJ basic software for single CPU including Java	Required for each ASGW
NT8035J-LW11A	Modbus communication portfolio license	Required for each ASGW

The following software is required as an engineering tool.

CD-ROM Code	Item	Remarks
NT203AJ-PC11E	Resource configurator	Loading a license for installation Modification of IP address

# 3. Functions

ASGW has the following functions.

1. Interface to DCS through Modbus RTU Slave or Modbus TCP Server
2. Read and write data for multi-analyzers (GC1000 MarkII, ASIU)
3. Mapping analyzer data to ASGW Modbus data area
4. Alarm information

## 3.1 Interface to DCS

ASGW has 2 functions as an interface to DCS.

- Modbus TCP Server \*
- Modbus RTU Slave (2 serial ports)

\*: It requires Rev.1.01.04 or later for ASGW and Rev. 1.80 or for Stardom OS.

Modbus RTU uses two RS-232C communication ports. Both ports have the same functions. Two communication ports can be used at the same time. Modbus RTU can be used with Modbus TCP at the same time.

### ● Max number of Client

When Modbus TCP Server is used, up to 4 clients (DCS) can be connected at the same time. When the multiple clients request the same command, the last requested command is accepted.

## 3.2 Address mapping

ASGW assembles the data from multiple analyzers and sends it to the DCS.

Max. number of analyzers connectable: 31

Function	Available address for mapping	Available points	GC1000 address area
Coil	01001 to 09000	8000	Coil, Input relay
Input relay	11001 to 19000	8000	Input relay
Holding register	41001 to 49000	8000	Input register, Holding register
Input register	31001 to 39000	8000	Input register

When the data address of analyzers is the coil or holding register, it is only possible to write to the specific address.

Refer to the Modbus interface table in section 3.4.

### 3.3 Alarm information

The conditions of communication with analyzers are mapped as alarm information to the input relay.

**In operation:**

This shows that ASGW is accessing the analyzers or PCAS Analyzer Server specified in the mapping file.

**Communication failure:**

This shows that a time-out error is occurring in communicating with an analyzer. Network line or analyzer failure may cause the error.

For analyzers connected to PCAS, communication error is indicated by both communication statuses between ASGW and PCAS or analyzers and PCAS.

**Write failure:**

It shows that a write error occurs on analyzer. The failure is reset when the next writing succeeds.

PCAS for ARCNET (PCAS/ARC) has multiple virtual analyzer tables, each of which ASGW accesses.

Alarm information is created for each analyzer, not for the entire PCAS/ARC.

### 3.4 Modbus interface table

ASGW has the function of Modbus RTU Slave.

This system covers the following function code and number of data with Modbus communication

**Modbus interface table**

Function	Function Code	BIT/WORD	Maximum data by access in one communication packet.
Read coil status	1 (0x01)	BIT	2000 bits
Read input relay status	2 (0x02)	BIT	2000 bits
Read holding registers	3 (0x03)	WORD	125 words
Read input registers	4 (0x04)	WORD	125 words
Write coil	5 (0x05)	BIT	1 bit
Write single register	6 (0x06)	WORD	1 word
Loopback test	8 (0x08)	WORD	1 word
Write multiple coils	15 (0x0F)	BIT	800 bits
Write multiple registers	16 (0x10)	WORD	100 words
Read device ID *	43 (0x2B)	ASCII string	

\*: Device ID consists of vendor, product code and revision number.  
 Vendor : "YOKOGAWA"  
 Product: "ASIU"  
 REVISION: "1.01.01" (example)

**Update rate:**

ASGW accesses analyzers every 100 ms and supports each read and write request sequentially.

Read and write is individually performed, so that it is possible to offer one read request and one write request at the same time.

**Coil (00001 to 09999)**

Data	Address	Description
Time setting request	00001	For all GC8000 or GC1000 MarkII connected to ASGW Time data should be set at the holding registers 40001 to 40004 before request. Value turns to "0" after writing. To set time to all analyzers or PCAS, #TSET must be specified as 255..
Individual time setting request	00nnn	Time is set for selected GC8000 or GC1000 MarkII. Time data should be set at the holding registers 40001 to 40004 before request. "nnn" is 100 + StnID * "nnn" (= 101 to 354) Value turns to "0" after writing. The setting for ASIU is invalid.
Mapping area	01001 to 09000	Setting the coil or input relay address of analyzers. ASGW only reads the input relay on analyzers and only writes the coil on analyzers.  Available is the following coils  GC8000 Refer to "5.1 Coils (command contacts)" in "GS 11B08B02-01E GC8000 Modbus Communication". However, "00004: Time Setting Request" is not available.  GC1000 MarkII Refer to "5.1 Coil (command contact)" in "GS 11B03G02-02E GC1000 MarkII Modbus Communication". However, "00004: Time Setting Request" is not available.  ASIU: 00101 to 00116: On command for DO01 to DO16 00201 to 00216: Off command for DO01 to DO16  Setting the other address is ignored. This value turn to "0" after writing.

\*: StnID is the identification number of an analyzer. StnID is related to an IP address in the mapping file (see 4.2 Data mapping).

**Input relay (10001 to 19999)**

Data	Address	Description
In operation	10xxx	The value indicates "1" when the analyzer and PCAS is communicating.  "xxx" is StnID* of the analyzer. "xxx" (=001 to 254)
Communication error	10yyy	The value indicates "1" when there is an error in communication with analyzers and PCAS. Input relay or inout register needs to be defined.  "yyy" is 300 + Stn ID "yyy" (= 301 to 554)
Write error	10zzz	The value indicates "1" when there is an error in writing data to analyzers and PCAS; it returns to "0" when the next writing successfully finishes.  "zzz" is 600 + Stn ID "zzz" (= 601 to 854)
Mapping area	11001 to 19000	Setting the input relay address of analyzers and PCAS. ASGW reads the addressed data from analyzers and PCAS.

\*: StnID is the identification number of an analyzer. StnID is related to an IP address in the mapping file (see 4.2 Data mapping).

**Holding register (40001 to 49999)**

Data	Address	Description
Time setting value	40001 40002 40003 40004	Setting the clock time. For data format, refer to "5.3 Holding Register (set data)" in "GS 11B08B02-01E GC8000 Modbus Communication" or "GS 11B03G02-02E GC1000 MarkII Modbus Communication".  The data are kept after writing on the analyzer and PCAS.
Mapping area	41001 to 49000	Setting the input register or holding register address of analyzers. ASGW only reads the input register on the analyzer. ASGW only writes the holding register on the analyzer. The holding registers are as follows.  GC8000: Refer to "5.3 Holding registers (setting data)" in "GS 11B08B02-01E GC8000 Modbus Communication". However, "40001-40004: Time Setting Request" is not available.  GC1000 MarkII: Refer to "5.3 Holding Register (set data)" in "GS 11B03G02-02E GC1000 MarkII Modbus Communication". However, neither "40001-40004: Time Setting Request" nor "41DDD: Analysis value" is available.  The other address area is ignored. The holding register in PCAS and ASIU can not be set.

**Input register (30001 to 39999)**

Data	Address	Description
Mapping area	31001 to 39000	Setting the input register address of analyzers. ASGW reads the addressed data from analyzers.

● **Access to the address not listed or mapped**

Access to the address that is not shown on the table or not mapped does not generate an error. However, the value of data is uncertain.

DCS can not write to the coil or holding register of ASGW that is not defined in the table above. However, with setting "#ADDR\_CHK, OFF" after-mentioned, DCS can write to the coil or holding register of ASGW.

● **Retry to writing**

When an error occurs in writing to the coil or holding register of analyzers and PCAS, ASGW tries to write the specified number of times. The number of retry times can be specified on the setting file.

● **Character time-out**

Value of character time-out for communication between DCS and Modbus RTU can be set according to communication speed. The value of mean time of each characters is set on the setting file.

● **Holding time of Data renewal bits**

The variable data bits such as Data renewal, Renewal of Calibration Coefficient and Alarm Status Change and be held for a constant time for DCS reading. Holding time can be specified. The unit is second.

● **TCP time-out**

Value of time-out for Modbus TCP communication. The unit is second. 1 second or more is recommended.

---

## 4. Engineering

ASGW requires the engineering at installation, modification and address mapping.

The install procedure of FCJ is referred to “STARDOM FCN/FCJ Software Installation” (IM 34P02Q91-01E), and “STARDOM FCN/FCJ Guide” (IM 34P02Q01-01E).

### 4.1 Installation

This section explains the setup of ASGW, license registration, loading of the application software and initializing of IP address.

#### 4.1.1 Preparation

- **Installation of the engineering tool**

Install the resource configurator software from CD-ROM (NT203AJ-PC11E) to PC.

Resource configurator software is an engineering tool for STARDOM FCN/FCJ.

- **Installation of the ASGW software**

Set the ASGW application software CD on PC.

Uncompress the following compressed file on PC.

(CDR)/ASGW/INSTALL\_ASGW.ZIP

Confirm the following folder is created.

[Uncompressed folder]/INSTALL\_ASGW

#### 4.1.2 Initial setting

- **Loading the license file**

Download the ASGW license file from the STARDOM license publishing web site.

Refer to D1. License in “STARDOM FCN/FCJ Guide (IM 34P02Q01-01E) about the license.

---

- **Setting the system card**

Set the system compact flash card for FCJ to PC by USB adaptor.

Run the following batch file.

```
[Uncompressed folder]/INSTALL_ASGW/install_ASGW.bat
```

This batch file sets the IEC application, Java application and system setting file on the system card.

System setting file includes initial IP address setting.

The initial IP address can be changed later.

After writing, the system card set on the CPU card of ASGW, and turn on the ASGW.

Initial IP address = 192.168.1.151



## **NOTE**

Do not format the system compact flash card. The card becomes invalid and new one is required.

---

- **Initializing with resource configurator**

The method of initial setting operation with resource configurator is described on the instruction manual of FCJ.

The work flow is described in this chapter. However, refer to the instruction manual for details of each operation.

- (1) Setting the IP address

Refer to 4.3.1 Modification of IP address.

- (2) Downloading the license file

Download the license file that is loaded from the STARDOM web site to ASGW with the resource configurator.

Refer to on-line help of resource configurator.

- (3) To enable Java, select General tab and click Use Java program.

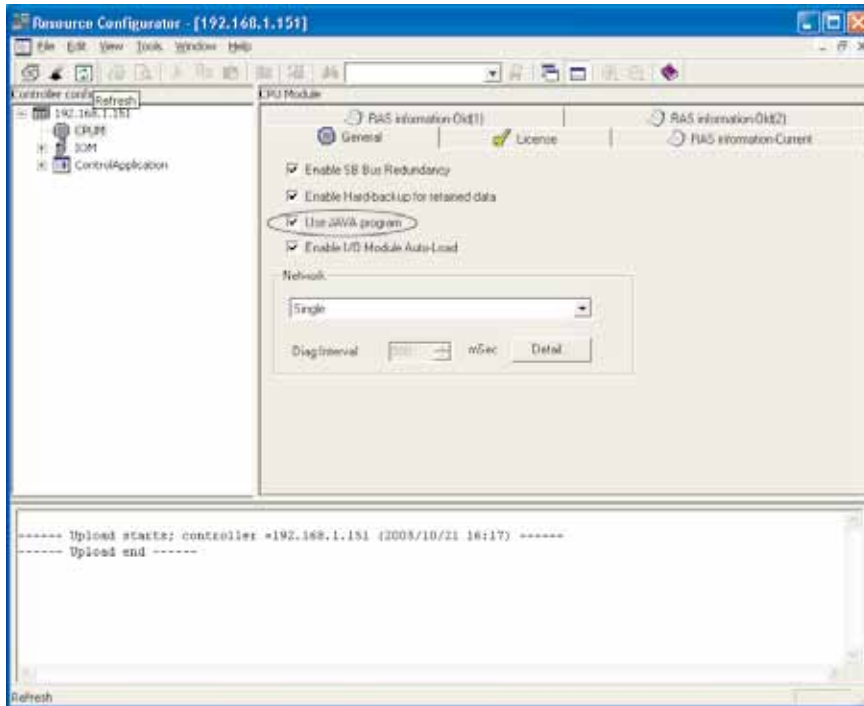

- (4) Setting the network

Specify the Ethernet connection for ASGW if it is single or duplex.

Ethernet of ASGW has dual or single type and dual type has duplex and separated mode.

After completing the above 3 items, download the information by [File] - [Download].

Reboot the ASGW by pressing Reset button or Web browser. After starting ASGW confirm that the IP address is correct by ping command of PC.

- (5) Allocating applications to the DO terminal (only when #DO function is used)

When the #DO setting is used to output alarm information to the DO terminal, the DO variable called device label in the ASGW application must be mapped to the I/O terminal by using the resource configurator. Immediately after the initial installation, the device label is not related to the I/O terminal.

The DO output definition is matched to the default factory setting of the device label of the system card. If none of the default settings are changed, this procedure is not needed.

- (6) Downloading settings

Download the five settings above to ASGW.

Resource configurator: [File] - [Download]

After finishing, reboot ASGW. Use the ping command from the PC to confirm that the IP address has been set correctly.

- (7) Setting the serial port

In the case of Modbus RTU, the communication parameters should be adjusted to a connected device.

Refer to 4.3.2 Modification of serial port setting.



## 4.2 Data mapping

### 4.2.1 Preparation

The IP addresses of analyzers, and mapping data of the Modbus address of analyzers onto the address of ASGW, are defined in the ASGW\_MAP.CSV file.

Mapping operation is complete when the file is transferred to ASGW with FTP and the ASGW is rebooted.

ASGW checks the file at start-up. Information of error diagnosis is confirmed with Web browser.

At the installation on ASGW a sample file is setted. Mapping operation is realized with modification of the sample file.

The mapping file does not depend on ASGW, so that the composition of mapped file is available in advance without ASGW.

```
#SLAVE, 1
#RETRY, 3

**** Station
#STN, 10, GC1000, 192.168.0.10, GC1000Mk2 at SiteA
#STN, 42, GC1000, 192.168.0.42, GC1000Mk2 at SiteB
#STN, 101, ASIU, 192.168.0.101, ASIU
#STN, 252, PCAS, 192.168.0.252, PCAS

**** Mapping
#MAP, 10, 1001, 1, RUN
#MAP, 42, 1002, 1, RUN
#MAP, 10, 1004, 2, STOP
#MAP, 42, 1005, 2, STOP
#MAP, 252, 11001, 11010, ID=10 A-ch Normal
#MAP, 252, 11002, 11042, ID=42 A-ch Normal
#MAP, 252, 11004, 11310, ID=10 B-ch Normal
#MAP, 252, 11005, 11342, ID=42 B-ch Normal
#MAP, 101, 31002, 30401, AI value of ASIU

**** Alarm DO ouput
#DO, 10, ALM_LVL1, 12, DO_12 output for alarm of Stn10
#DO, 10, ALM_LVL2, 13, DO_13 output for alarm of Stn10
#DO, 42, ALM_LVL1, 3, DO_3 output for alarm of Stn42
```

Example of mapping file

```

#SLAVE, 1
#RETRY, 3

**** Station
#STN, 1, GC1000, 192.168.1.252, GC1000Mk2(ARCNET)
#STN, 2, GC1000, 192.168.1.252, GC1000Mk1(ARCNET)
#STN, 3, GCIU, 192.168.1.252, GCIU(ARCNET)
#STN, 10, GC1000, 192.168.1.10, GC1000Mk2 at SiteA
#STN, 42, GC1000, 192.168.1.42, GC1000Mk2 at SiteB
#STN, 101, ASIU, 192.168.1.101, ASIU
#STN, 247, PCAS, 192.168.1.252, PCAS(ARCNET)

**** Mapping
#MAP, 1, 1001, 1, RUN
#MAP, 2, 1002, 1, RUN
#MAP, 10, 1003, 1, RUN
#MAP, 42, 1004, 1, RUN
#MAP, 1, 1011, 2, STOP
#MAP, 2, 1012, 2, STOP
#MAP, 10, 1013, 2, STOP
#MAP, 42, 1014, 2, STOP
#MAP, 1, 11001, 10001, Normal
#MAP, 2, 11002, 10001, Normal
#MAP, 10, 11003, 10001, Normal
#MAP, 42, 11004, 10001, Normal
#MAP, 1, 11011, 10002, Error
#MAP, 2, 11012, 10002, Error
#MAP, 10, 11013, 10002, Error
#MAP, 42, 11014, 10002, Error
#MAP, 101, 31002, 30401, AI value of ASIU

**** Alarm DO ouput
#DO, 10, ALM_LVL1, 12, DO_12 output for alarm of Stn10
#DO, 10, ALM_LVL2, 13, DO_13 output for alarm of Stn10
#DO, 42, ALM_LVL1, 3, DO_3 output for alarm of Stn42

```

Example of mapping file (include ARCNET)

### 4.2.2 Loading a mapping file

After the installation of ASGW, turn on the power and connect the ASGW to PC with Ethernet cable.

Open the web browser on PC and input the address of ASGW as http://(IP address of ASGW).

When the diagnostic window of ASGW is displayed, click the “File folder (FTP)”.

FTP windows appears and account and password are required.

Enter the following characters.

Account: “stardom”  
Password: “YOKOGAWA”

Mapping file “ASGW\_MAP.CSV” is displayed on FTP window.

Move this file to PC.

### 4.2.3 Setting

This file consists of text characters. Editing can be done with “Notepad” software, but “MS-Excel” software is recommended. The edited file should be saved with “CSV” as an extension.

Each line has meaning in the map file. A line beginning with character # is interpreted as a meaningful line.

And a comment line does not begin with character “#”.



#### NOTE

Comment lines must not include the # character, otherwise ASGW may not work properly.

#### #SLAVE, n

This n is the Slave ID when DCS accesses to ASGW with Modbus interface and commonly uses on the 2 communication ports. Range is 1 to 247.

#### #RETRY, m

This m is the number of retry times when a write error occurs. Range is 1 to 32767.

#### #TOUT, t

This t is character time-out in the communication between DCS and Modbus RTU. Adjust the value depending on communication speed. Unit is ms [millisecond] and range is 10 to 5000.

#### #KEEP\_BIT, t

This specifies the holding time of the variable data bits. This t is the time (sec) to hold.

This function can be used on Rev. 1.01.04 or later of ASGW. The default value is 5 sec, and range is 0 to 3276.

#### #TCP\_TIMEOUT, t

This specifies time-out value of Modbus TCP. This t is the time-out value (sec).

This function can be used on Rev. 1.01.03 or later of ASGW. The default value is 30 sec, and range is 1 to 100.

#### #TSET, StnID

Writing in address 00001 of the coil in the Modbus address table carries out time setting in all devices that have a time setting function. If StnID is set to 255 in the #TSET line, time setting is carried out for all devices; if StnID is set to any number from 1 to 254, the setting is effective only for a specified device.

### ● Specifying analyzers and PCASs

Up to 31 analyzers and PCASs can be specified to be connected.

A unique StnID number must be allocated to each analyzer and PCAS. This StnID is key data on Modbus interface.

Format = “#STN, StnID, StnType, IP\_Address”

#STN	Key word. The line start from “#STN” is recognized as one for specifying analyzers.
StnID	ID number of analyzer (1-254)
StnType	Type: GC8000/GC1000/ASIU/GCIU/PCAS
IP_Address	IP address of analyzer

Example “#STN, 3, GC1000, 192.168.0.1”



The maximum number of ASGW connections applies to PCAS. When ASGW has already been connected to two PCASs, it can accept up to 29 analyzers.

● **Definition of Mapping**

The Modbus address of an analyzer is mapped to ASGW.

Refer to “3.4 Modbus interface tables” for available mapping conditions.

Format = “#MAP, StnID, ASGW\_Address, Target\_Address”

<b>#MAP</b>	Key word. The line start from “#MAP” is recognized as one for definition of mapping. “#STN” needs to be defined firstly. “#MAP” defined before “#STN” is defined complains.
<b>StnID</b>	StnID of the analyzer (defined in #STN)
<b>ASGW_Address</b>	Modbus address of ASGW
<b>Target_Address</b>	Modbus address of the target analyzer

Example: “#MAP, 3, 11001, 10001”

The order of line is not restricted, and blank line is ignored.

● **Specifying DO output**

The alarm status of analyzers is output from the DO terminal of ASGW. Up to 16 points can be specified. Based on two pieces of alarm information (addresses 10001 and 10002) of GC1000 which can be read through the Modbus I/F, two statuses are created: ALM\_LVL1 and ALM\_LVL2. Either of these statuses can be mapped to the DO terminal of ASGW. At the start-up of ASGW, both ALM\_LVL1 and ALM\_LVL2 are OFF.

	GC1000 Address 10002: ON	GC1000 Address 10002: OFF
GC1000 Address 10001: ON	ALM_LVL1: keep the last value ALM_LVL2: keep the last value	ALM_LVL1: OFF ALM_LVL2: OFF
GC1000 Address 10001: OFF	ALM_LVL1: ON ALM_LVL2: OFF	ALM_LVL1: OFF ALM_LVL2: ON

Format: #DO, StnID, KeyWord, DO number

<b>#DO</b>	The keyword for defining the mapping. A line starting with #DO is recognized as the line for defining the alarm output at the DO terminal.
<b>StnID</b>	StnID of an analyzer which monitors alarms (defined in #STN)
<b>KeyWord</b>	Either ALM_LVL1 or ALM_LVL2 is specified.
<b>DO number</b>	The DO number of ASGW from which alarms are output (1 to 16)

Definition example: #DO, 3, ALM\_LVL1, 12

● **Definition of Address Checking Function**

Address checking function for the coil and holding register to all analyzers is overrode.

Format = “#ADDR\_CHK, OFF”

Set: ON (valid) / OFF (invalid)

- \*: Default setting is “ON (valid)”.
- \*: The setting for “#MAP” is valid only after “#ADDR\_CHK” is defined.

Example:  
 #MAP, xxxx, xxxx → Check target  
 #MAP, xxxx, xxxx → Check target  
 #ADDR\_CHK, OFF  
 #MAP, yyyy, yyyy → Exempt from check  
 #MAP, yyyy, yyyy → Exempt from check  
 #ADDR\_CHK, ON  
 #MAP, zzzz, zzzz → Check target  
 #MAP, zzzz, zzzz → Check target

### 4.2.4 Transfer to ASGW

Open the FTP window on PC that is shown in 4.2.2.  
 Move the modified mapping file to FTP window.  
 Restart ASGW after over writing is complete.

### 4.2.5 Diagnosis information

After re-starting the ASGW, Open the diagnostic window of ASGW.  
 When “check result” is clicked, the diagnosis information window appears.  
 The contents are as follows.

- (a) Out of range addressing
- (b) Duplicated addressing
- (c) Invalid combination of mapping

Modify the setting file according to the error that is shown in this window.  
 If the file includes errors, ASGW ignores the error occurred line on the file.

### 4.2.6 Transferring the mapping file by means other than Internet Explorer

#### A. Restriction on functions with IE7 or later

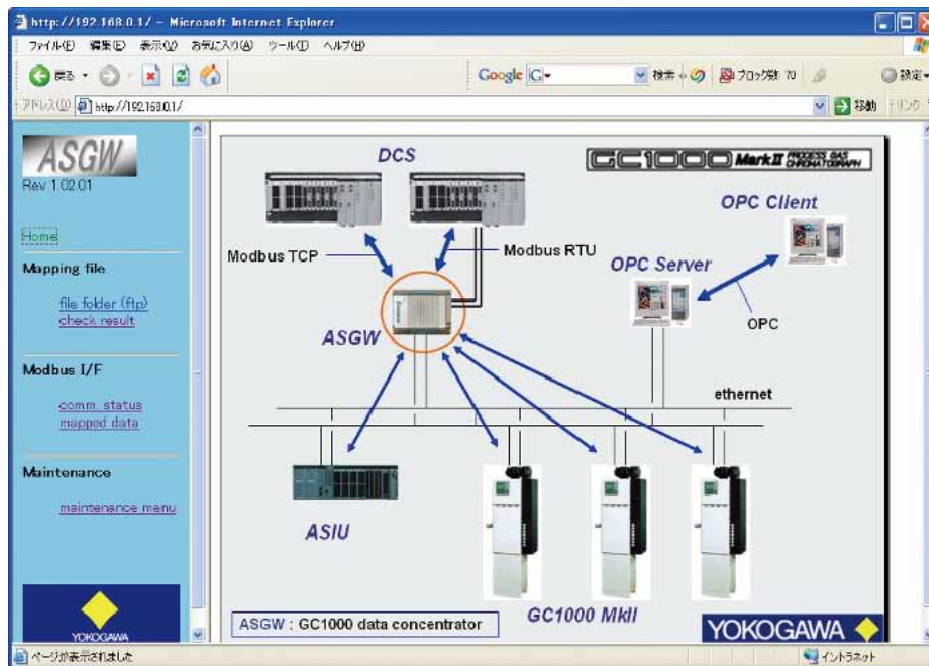

As an alternative, enter FTP commands in the Command Prompt window to transfer the mapping file.

## B. Uploading/downloading the mapping file with FTP commands

- (1) Login to ASGW.  
C:\MyWork>ftp 192.168.0.151 ← Start FTP communication  
Connected to 192.168.0.1.  
220 FCX STARDOM(FCJ-1) FTP server ready (JRS:R2.04.12).  
User (192.168.0.1:(none)): stardom ← Input Account  
331 Password required for stardom.  
Password:xxxxxxx ← Input Password (not displayed)  
230 User stardom logged in.
- (2) Move to the specified folder.  
ftp> cd conf/users/appf/ASGW ← Change directory  
250 Changed directory to "/JEROS/CONF/USERS/APPF/ASGW".
- (3) Confirm the mapping file; ASGW\_MAP.CSV  
ftp> dir ← Confirm directory  
200 Port set okay.  
150 Opening ASCII mode data connection for /JEROS/CONF/USERS/APPF/ASGW  
(192.168.0.60,3980).  
drw-rw-rw- 1 2008 03:09:50 2048 Jun 27 03:09 .  
drw-rw-rw- 1 2005 18:07:58 2048 Aug 11 2005 ..  
-rw-rw-rw- 1 2008 03:09:52 34250 Jun 27 03:09 ASGW\_MAP.CSV  
226 Transfer complete.  
ftp: 200 bytes received in 0.00Seconds 200000.00Kbytes/sec.
- (4) Upload (load the mapping file).  
ftp> get ASGW\_MAP.CSV  
200 Port set okay.  
150 Opening ASCII mode data connection for /JEROS/CONF/USERS/APPF/ASGW/  
ASGW\_MAP.  
CSV (192.168.0.60,3982) (34250 bytes).  
226 Transfer complete.  
ftp: 34250 bytes received in 0.19Seconds 183.16Kbytes/sec.
- (5) Download (Overwrite the mapping file).  
ftp> put ASGW\_MAP.CSV  
200 Port set okay.  
150 Opening ASCII mode data connection for /JEROS/CONF/USERS/APPF/ASGW/  
ASGW\_MAP.CSV (192.168.0.60,3983).  
226 Transfer complete.  
ftp: 34250 bytes sent in 0.01Seconds 2283.33Kbytes/sec.
- (6) Finish the procedure.  
ftp> quit ← Quit FTP communication  
221 Bye...see you later.  
C:\MyWork> ← Close Command prompt

## 4.3 Additional Information

This chapter explains how to change the IP address of ASIU/ASGW and the property of serial port.

The tool software that is shown below needs to be installed on PC.

CD-ROM Code	Item
NT203AJ-PC11E	Resource configurator

### 4.3.1 Modification of IP addressing setting

#### ■ Preparation of PC

Connect the PC on which resource configurator software is installed to ASIU/ASGW with Ethernet

#### ■ Starting the ASIU/ASGW on the IP address setting mode

There are two methods of starting the ASIU/ASGW on the IP address setting mode.

One is use of web browser on PC, the other is use of switches on CPU module.

Select one depending on the location of ASIU/ASGW.

During the IP address setting mode, LEDs on CPU module of ASIU/ASGW are indicated as follows.

HRDY: Flashing quickly

RDY: Flashing slowly

CTRL: Not lit

To release this mode, press the RESET button or turn off the power.

#### ● Method of use the switch on CPU module of ASIU/ASGW

- (1) Turn on ASIU/ASGW, or press "RESET" button.
- (2) ASIU/ASGW starts and during the "HRDY" and "RDY" LED are flashing rapidly (about for two seconds), press "SHUTDOWN" button once.
- (3) ASIU/ASGW starts on IP address setting mode.

● **Method of use web browser on PC.**

- (1) Connect ASGW communication entering URL as follows on Web browser.  
URL = http://FCJ's IP address/MNT

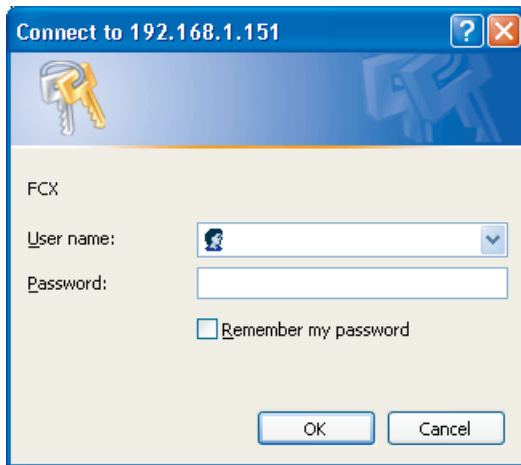

User Account = "stardom"  
Password = "YOKOGAWA"

- (2) Click the Maintenance Menu

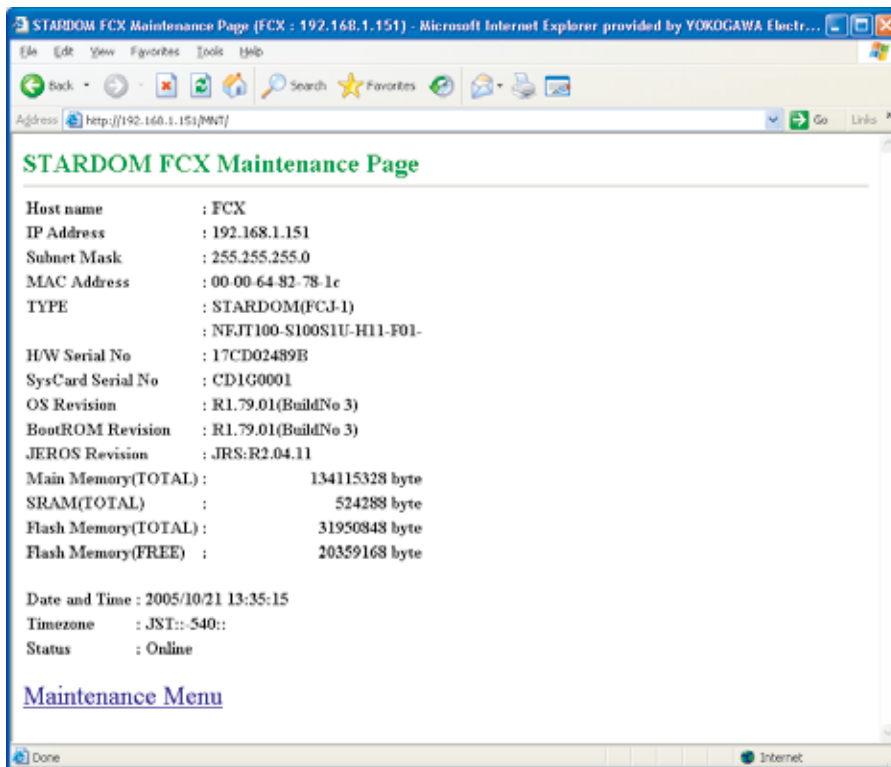



(3) Click the Reboot

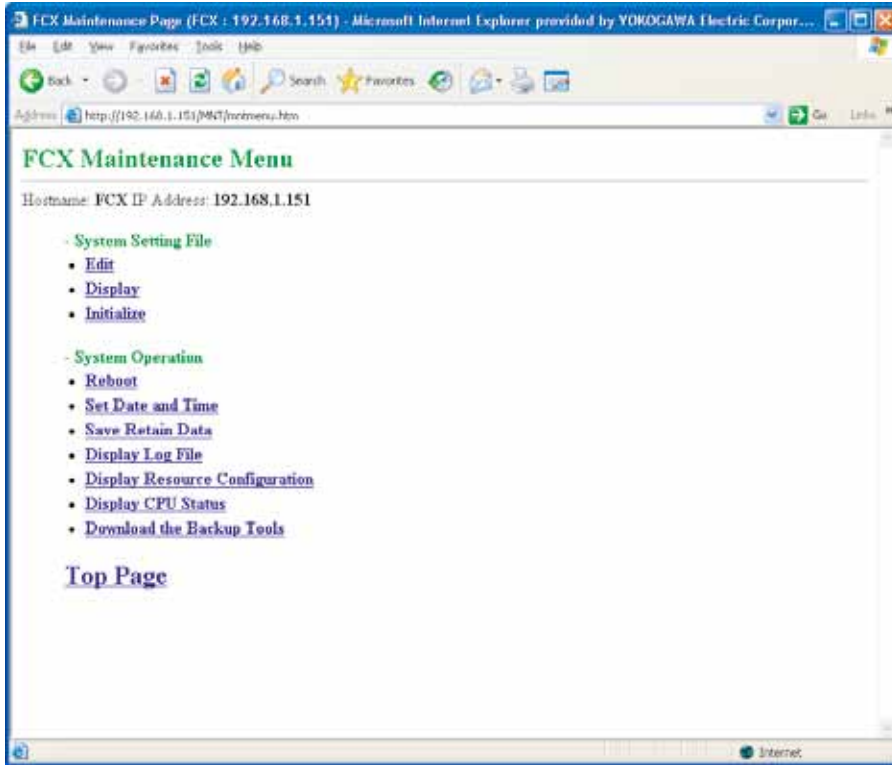

(4) Select the Reboot (IP Address Setting Mode) and press “OK”

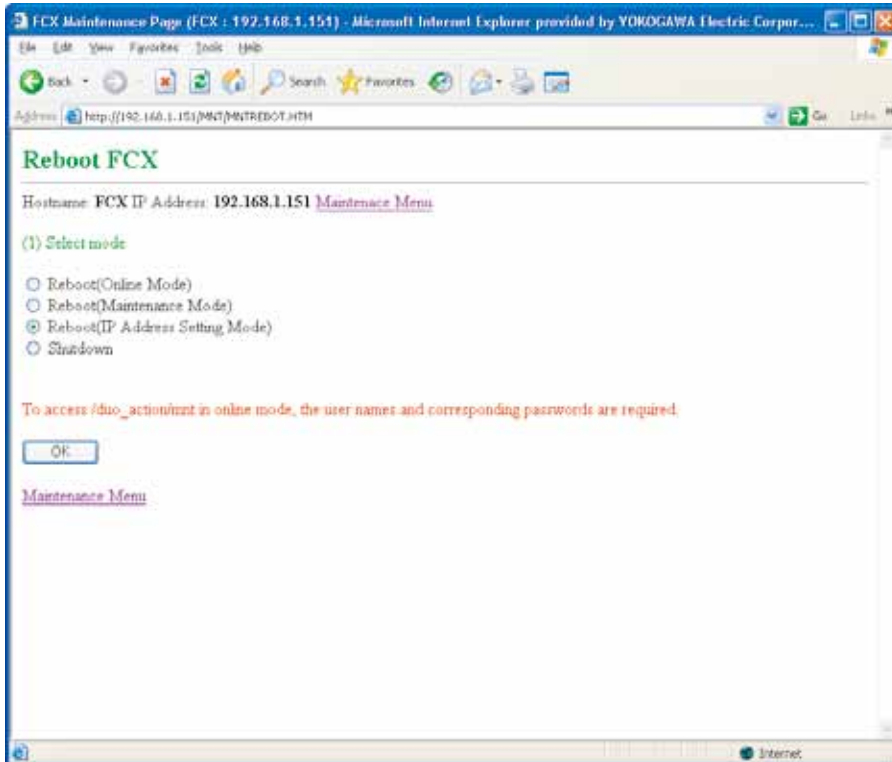

ASIU/ASGW restarts on IP address setting mode.

## ■ Setting IP address

Start the resource configurator software on PC and wait for a message “A new controller is connected”.

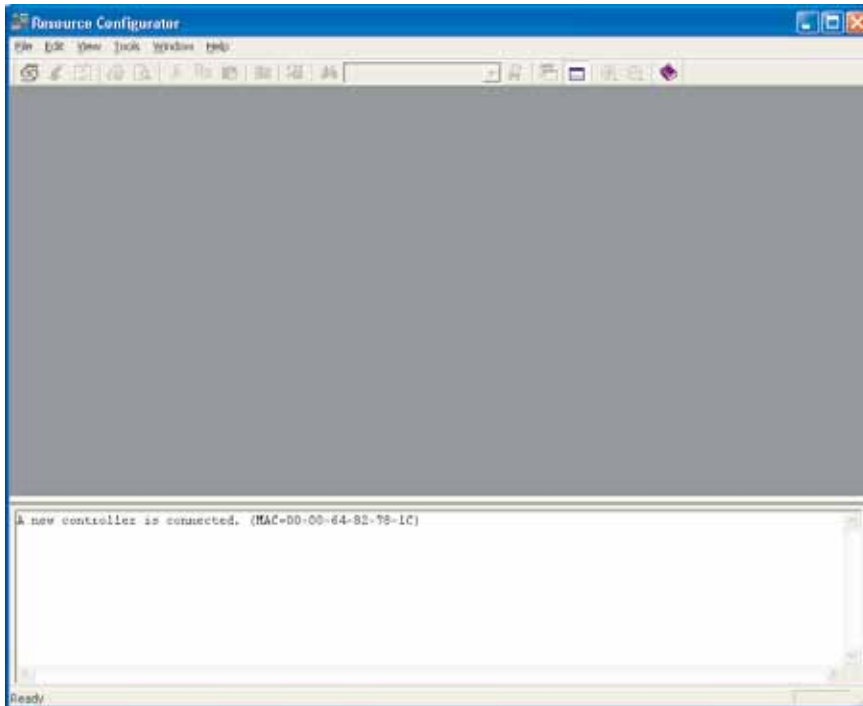

When the message appears, select the “Setting IP Address” on “File” menu.

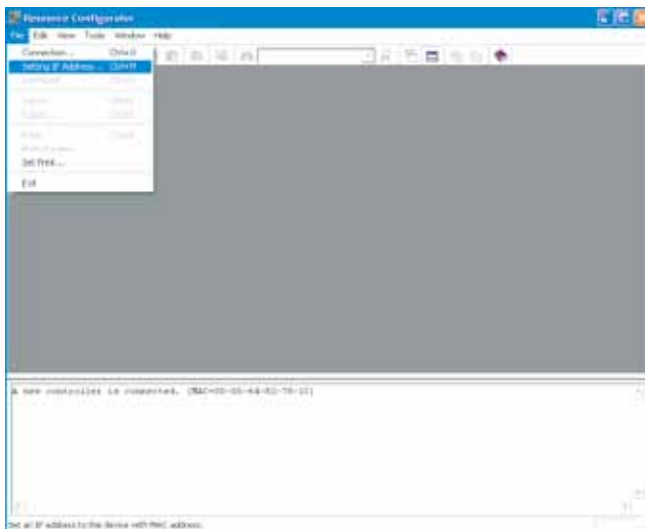

IP address, Subnet mask, Gateway and Time zone parameters are set on this dialogue window. Reboot the ASIU/ASGW after the setting.

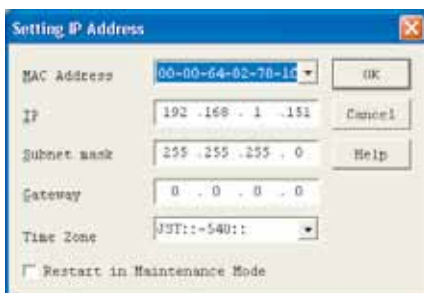



IP address of ASGW in the redundant network must be set up from 192.168.0.1 to 192.168.0.126.

### 4.3.2 Modification of serial port setting

In the case of using the Modbus RTU as external interface of ASIU/ASGW, this operation is required.

ASGW has two communication ports and both initial setting data are as follows.

Baudrate	=9600
DataBitLength	=8
StopBitLength	=1
Parity	=NONE

After ASIU/ASGW mode is changed to maintenance mode, the communication port is set with the maintenance window on web browser.

Refer to the guide of STARDOM FCN/FCJ (IM 34P02Q01-01E) about the method of modification.

Setting parameters are “COM1 Port Setting File” or “COM2 Port Setting File”.

### 4.3.3 Allocating DO information

Allocate the device label of ASGW to the DO terminal before outputting DO information of the ASGW application to the terminal. The device label of ASGW is the default factory setting.

#### (1) Confirming the current state of the ASGW application

Confirm that the ASGW application has been successfully downloaded. After connecting by using Resource Configurator, click the ControlApplication/DevLabelVar. Then, confirm that the value of I/O Category is O\_Sts and the value of Device Label is Q\_D\_17 to Q\_D\_32, as shown in the following figure.

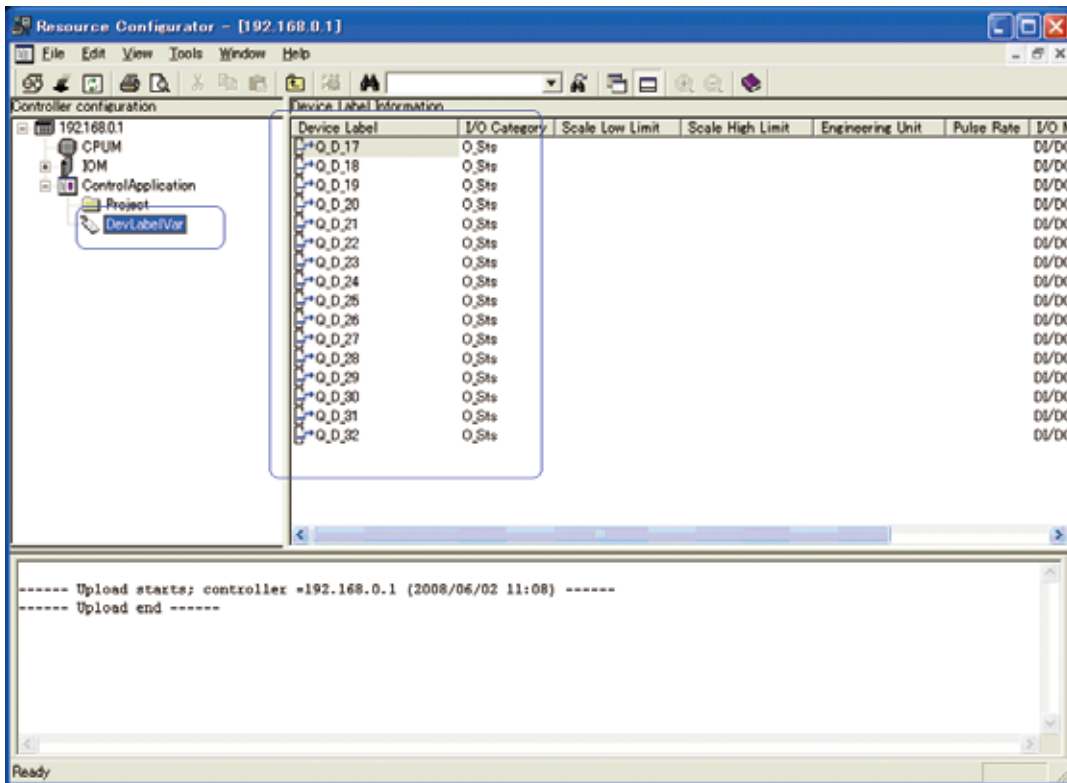

**(2) Confirming the current device**

Check that the settings of ASGW remain as the defaults, which means the setting values of ASGW are equal to those of the ASGW application. Click IOM to display DI/DO. Then, confirm that the values of Signal Type and Device Label corresponding to Channel 17 to 32 are SO and Q\_D\_17 to Q\_D\_32, respectively.

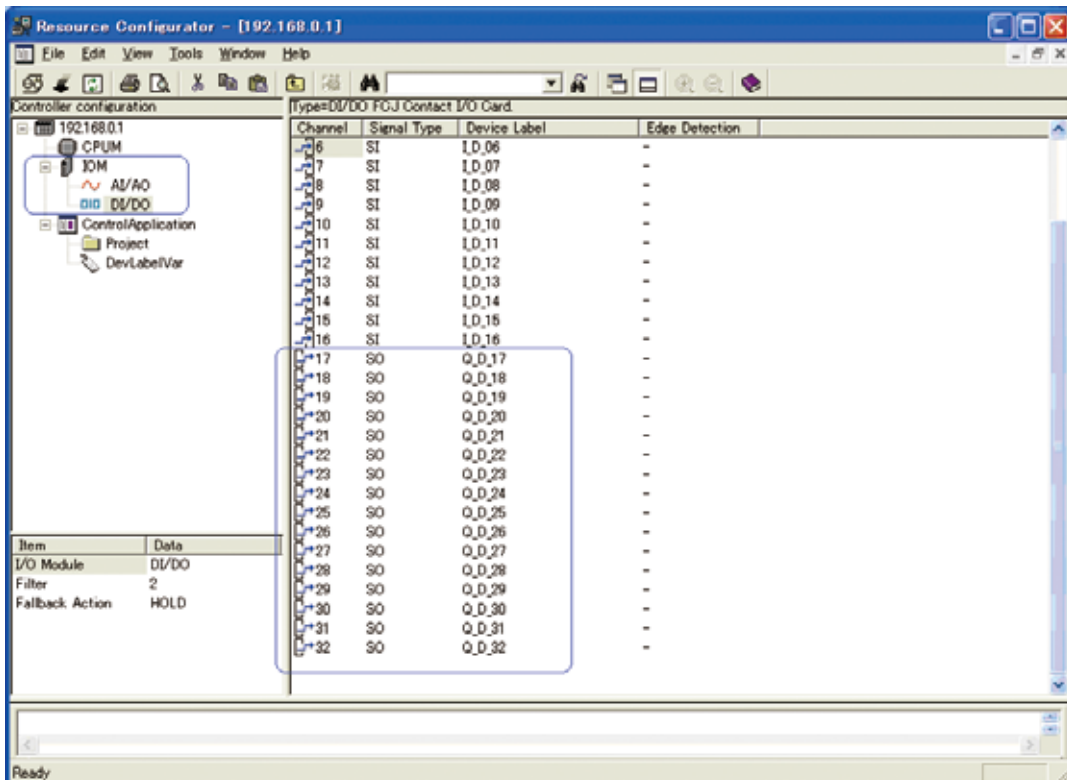

If the values of Device Label (Q\_D\_xx) in both (1) and (2) are the same, the procedures described in (3) can be skipped.

### (3) Allocating DO information if the above values are not the same

If the values in (1) and (2) are not the same, the values of Device Label in DI/DO must be set to those shown in DevLabelVar. Copy all values of Device Label in DevLabelVar and paste them to the corresponding values of Device Label in DI/DO.

Copy: Select the values of Device Label shown in (1). Then, right-click on the selected area and choose Copy from the context menu.

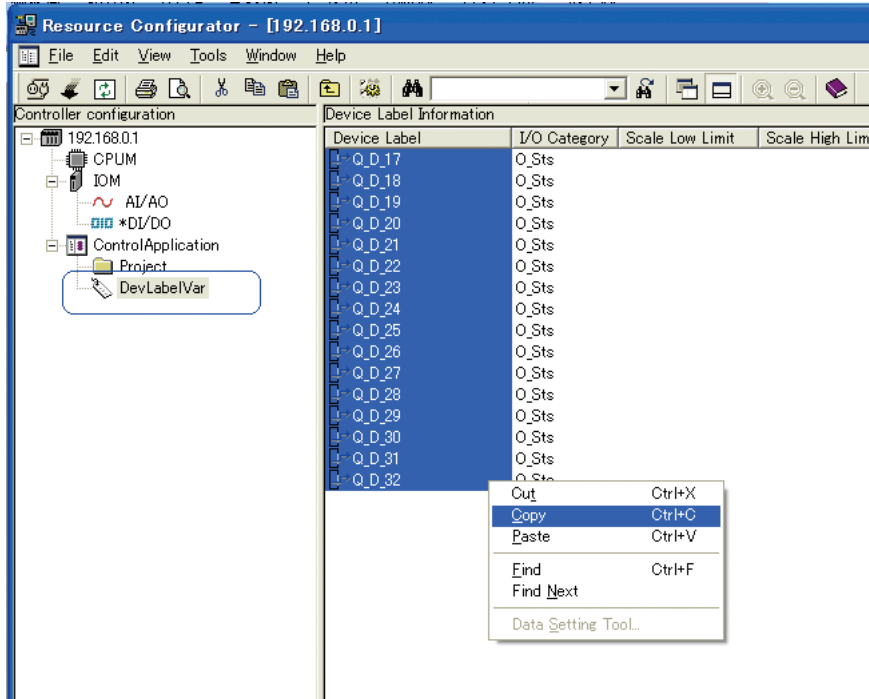

Paste: Select Channel 17 shown in (2), which is the first DO value of Device Label. Then, right-click and choose Paste from the context menu.

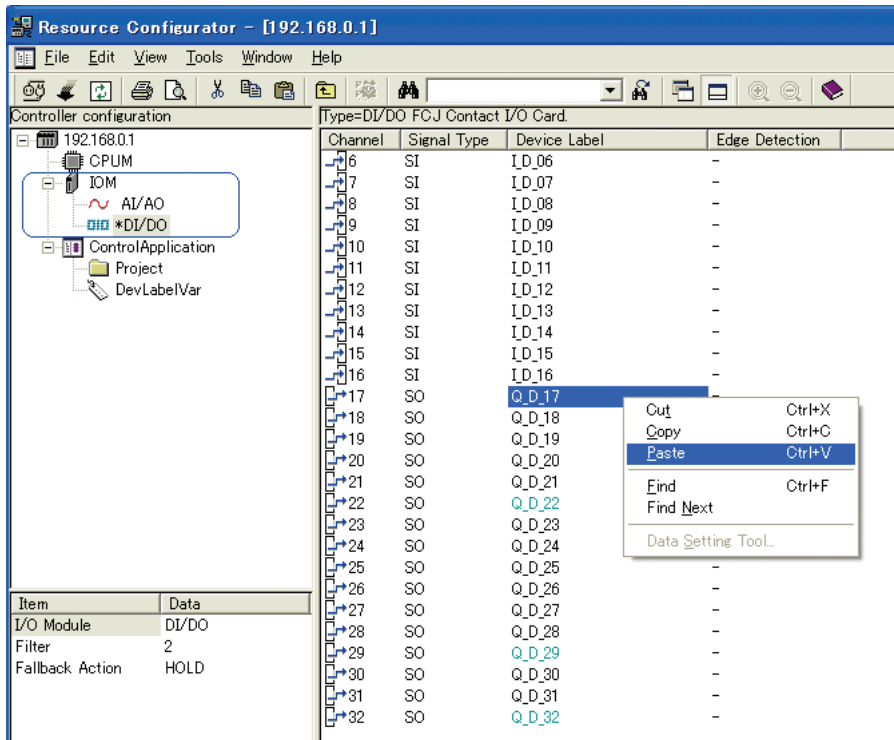

Download: Send the replaced values of Device Label to ASGW by [File] – [Download].

# 5. Diagnostic Window

The following maintenance and various type of diagnostic can be executed by the diagnostic window.

- (1) The transfer of the mapping file and error diagnostic
- (2) The communication status check of GC8000/GC1000 MarkII/ASIU and display of the mapping data
- (3) The maintenance of FCJ

## 5.1 Start-up of the diagnostic window

Enter http:// (IP address) on web browser.

(Ex.) http://192.168.0.151/

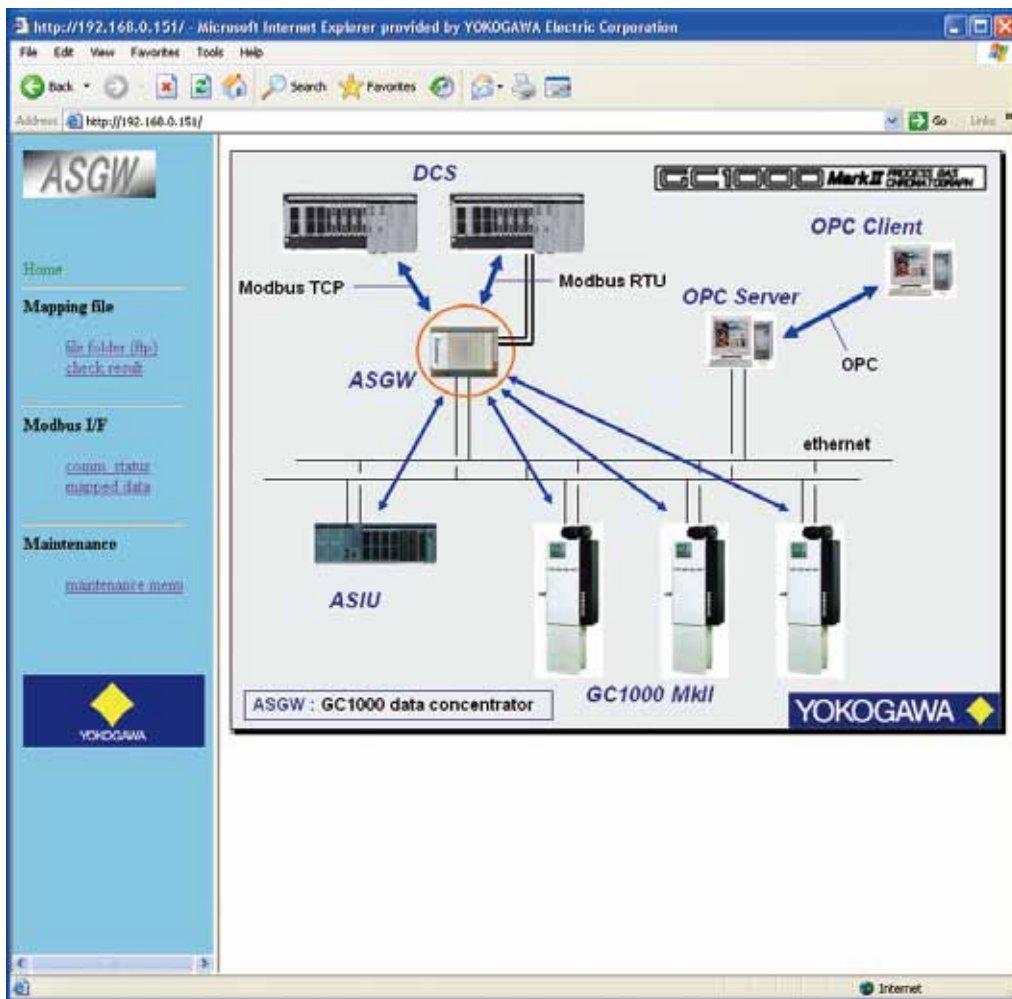

## 5.2 Data transfer of the mapping file and error diagnostic

FTP window is displayed when [Mapping File] - [file folder (ftp)] is clicked.

Enter the following account and password.

Account: "stardom"

Password: "YOKOGAWA"

Mapping file "ASGW\_MAP.CSV" is displayed on FTP window. The renewal of the Mapping file is executed by overwriting this file.

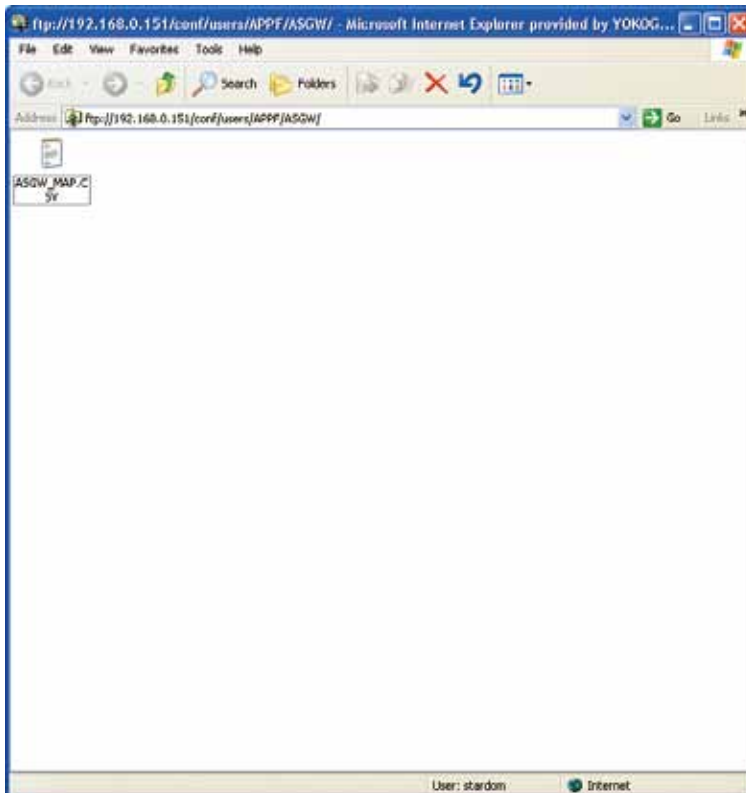
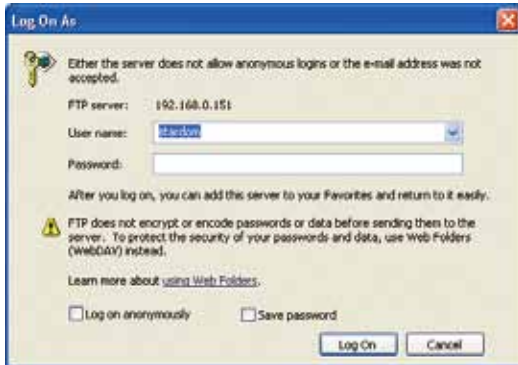

The diagnostic information of the mapping file is displayed by clicking [Mapping File] - [check result]. The content is as follows.

- (a) Out of range addressing
- (b) Duplicated addressing
- (c) Invalid combination of mapping

This window indicates where and what kind of error occurred, then correct the error by modifying the mapping file based on this information. When being included error, ASGW is operated by ignoring the line where the error occurs.

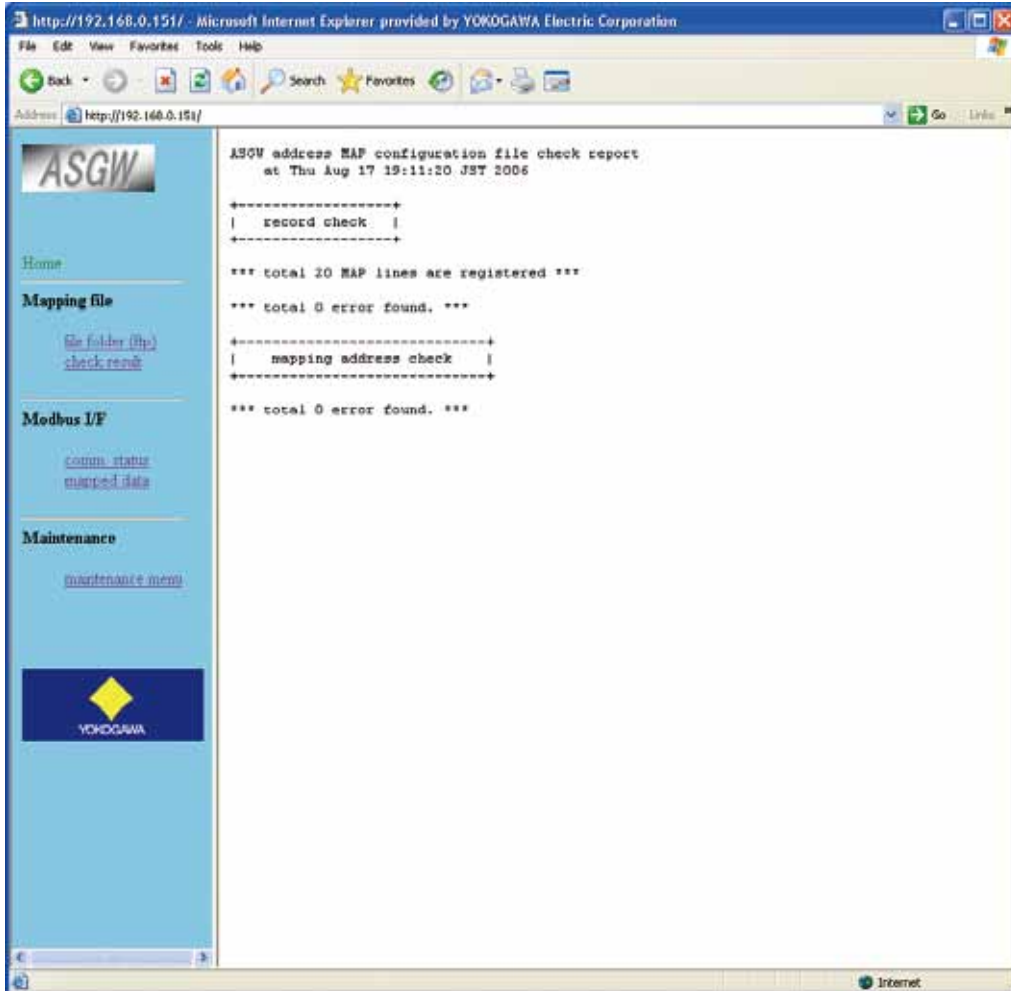



### 5.3 Checking the analyzer communication status and displaying the mapping data

The communication status window is displayed when [Modbus I/F] - [comm.status] is clicked.

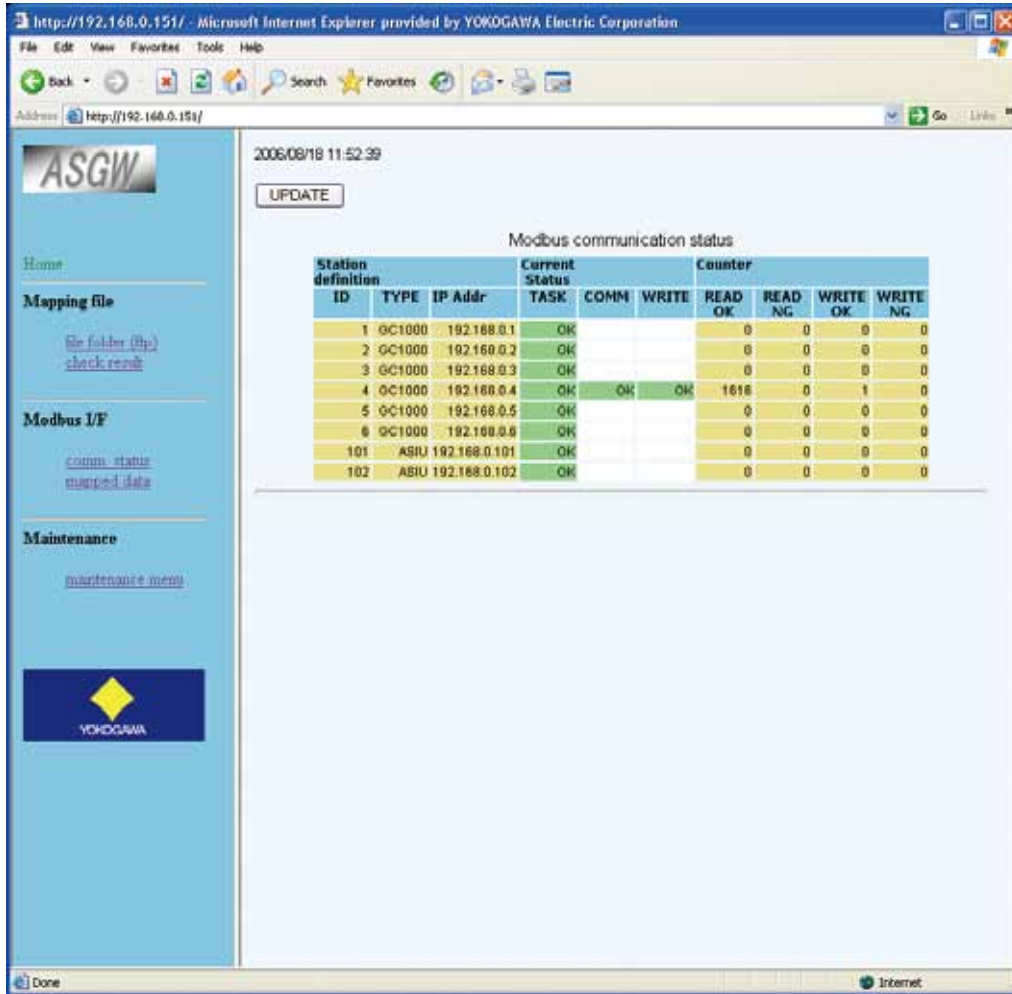

- UPDATE: The data is updated.
- ID: StnID (define in the mapping file)
- TYPE: GC8000/GC1000/PCAS/ASIU (defined in the mapping file)
- IP Addr: IP address (define in the mapping file)
- TASK: The status is "OK" when the communication task is in operation.
- COMM: The status is "NG" when the communication error occurs.
- WRITE: The status is "NG" when it fails the writing, but is "OK" when it successes.
- READ OK: Number of success in reading
- READ NG: Number of failure in reading
- WRITE OK: Number of success in writing
- WRITE NG: Number of failure in writing

The mapping data window is displayed when [Modbus I/F] - [mapped data] is clicked.

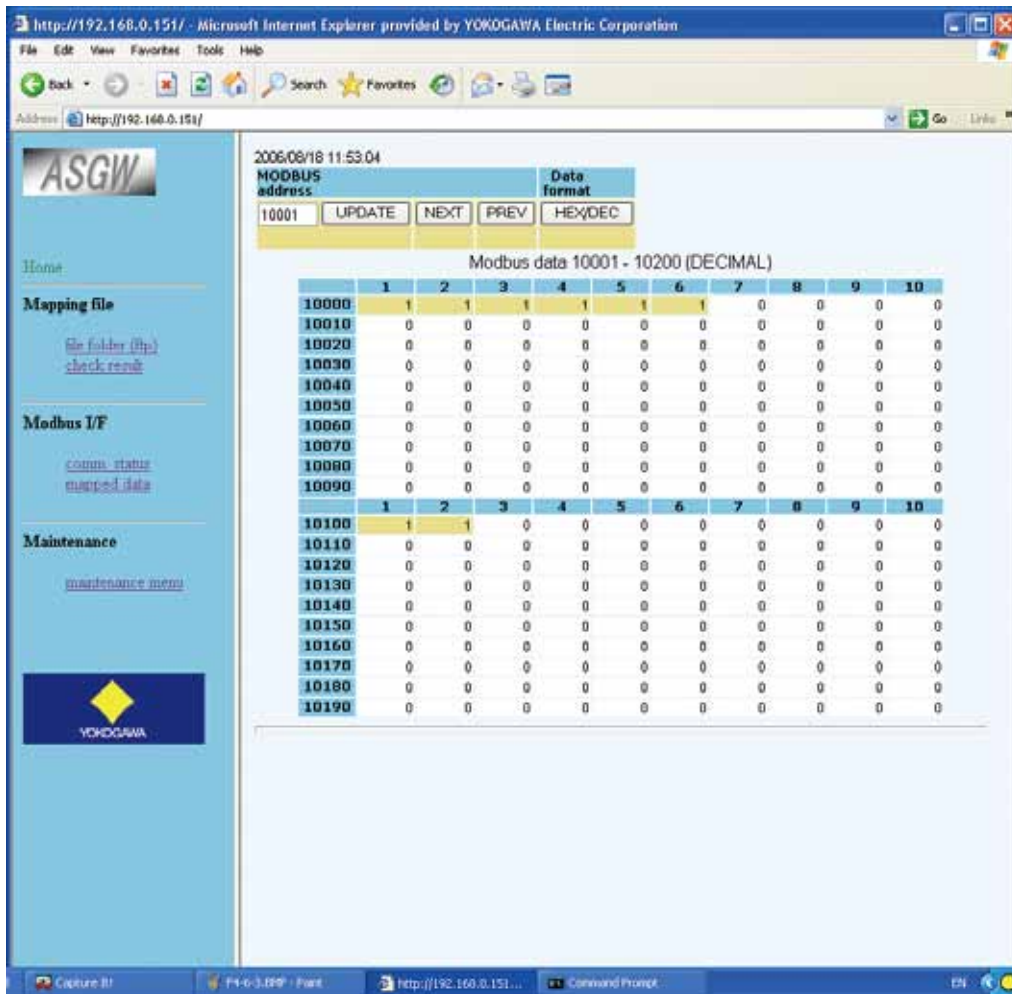

MODBUS address: 40 data is displayed from the specified address.

UPDATE: The data is updated.

NEXT: It indicate the data of the next address

PREV: It indicate the data of the previous address

HEX/DEC: Displayed format (HEX = Hexadecimal, DEC = Decimal)

## 5.4 Maintenance of FCJ

FCJ Maintenance window is displayed when [Maintenance] - [maintenance menu] is clicked.

It is available to start-up the FCJ on IP address setting mode or change the setting of serial port on Maintenance mode.

Refer to "STARDOM FCN/FCJ Guide" (IM 34P02Q01-01E) for more detail.

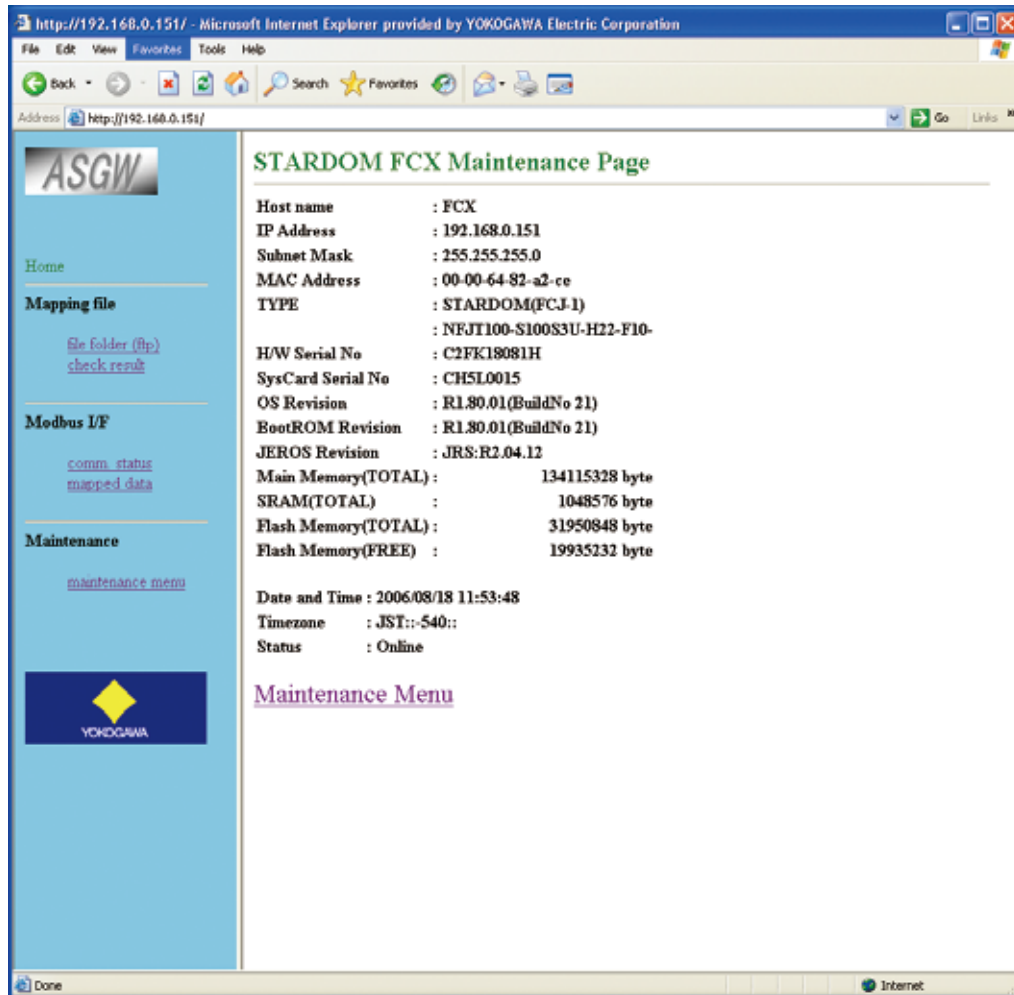

# 6. OPC DA 2.0 Interface

This chapter explains the OPC DA 2.0 interface of ASGW and ASIU.

Adding an OPC server of STARDOM to the system allows ASGW/ASIU to have the OPC interface. There is no need to add any special settings to the ASGW/ASIU application. Mapping Modbus data of ASIU to ASGW allows ASIU data to be read and written by accessing ASGW through the OPC interface.

## 6.1 System Configuration

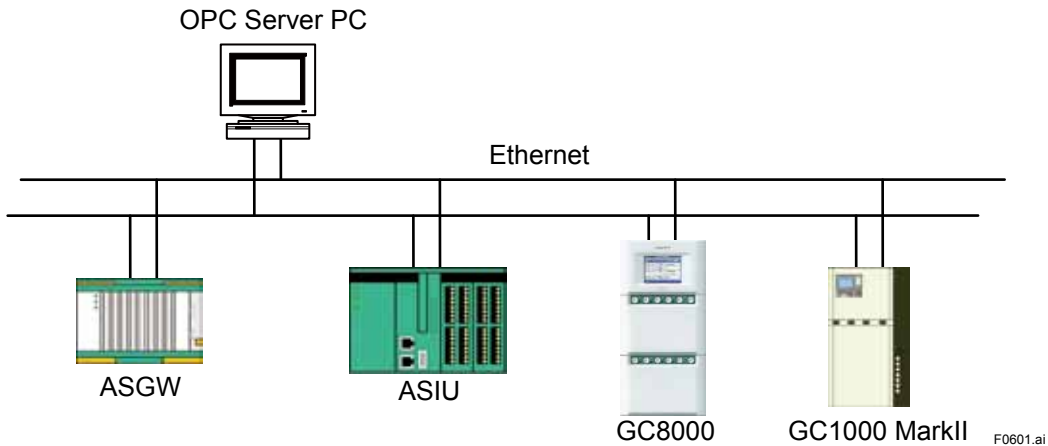

## 6.2 Software Required

ASGW do not require additional software to be installed for OPC. The STARDOM software listed below is required for a PC on which an OPC server is to be installed.

Model	Item	Remark
NT781AJ	FCN/FCJ OPC Server for Windows	
NT783AJ	Redundant Network Function License for FCN/FCJ OPC Server	Required only for redundant network.

## 6.3 Installation and Settings

For installation and settings of the OPC server and the duplexed package, refer to their respective user's manuals or online help.

## 6.4 Update rate

Data for the OPC interface is updated every second. Therefore, a delay of about one second may occur when the OPC client reads the latest data from analyzers.



Separating OPC data from Modbus data causes hogging of the CPU. To avoid this, the OPC data update rate is set to 1 second while the Modbus communication is updated every 200 ms.

## 6.5 List of OPC Data Names

The table below shows a list of ASGW/ASIU's data names that can be accessed via STARDOM OPC DA2.0 server. Data names are common to ASGW and ASIU.

ASGW/ASIU's node name designated in the setting file on the STARDOM OPC server is assigned to "Node."

OPC data name example 1: ASGW01!@GV.IREG2(312) represents the address 32312 of the Modbus data of ASGW01.

OPC data name example 2: ASGW01!@GV.COIL2(1000) represents the address 03000 of the Modbus data of ASGW01.

### ● COIL (00001 to 09000)

Read/write is possible. Writing data onto unmapped areas is ignored. Unmapped address data is always read as "FALSE".

OPC Data Name	OPC Data Type	Function	Remark
Node!@GV.COIL0(n)	VT_BOOL	Modbus Address 00001 to 01000	n = 1 to 1000
Node!@GV.COIL1(n)	VT_BOOL	Modbus Address 01001 to 02000	n = 1 to 1000
Node!@GV.COIL2(n)	VT_BOOL	Modbus Address 02001 to 03000	n = 1 to 1000
Node!@GV.COIL3(n)	VT_BOOL	Modbus Address 03001 to 04000	n = 1 to 1000
Node!@GV.COIL4(n)	VT_BOOL	Modbus Address 04001 to 05000	n = 1 to 1000
Node!@GV.COIL5(n)	VT_BOOL	Modbus Address 05001 to 06000	n = 1 to 1000
Node!@GV.COIL6(n)	VT_BOOL	Modbus Address 06001 to 07000	n = 1 to 1000
Node!@GV.COIL7(n)	VT_BOOL	Modbus Address 07001 to 08000	n = 1 to 1000
Node!@GV.COIL8(n)	VT_BOOL	Modbus Address 08001 to 09000	n = 1 to 1000

### ● DSCI (10001 to 19000)

Read only. Writing through the OPC interface does not cause an error, but nothing can be written onto the Modbus area of ASGW/ASIU. Unmapped address data is always read as "FALSE".

OPC Data Name	OPC Data Type	Function	Remark
Node!@GV.DSCI0(n)	VT_BOOL	Modbus Address 10001 to 11000	n = 1 to 1000
Node!@GV.DSCI1(n)	VT_BOOL	Modbus Address 11001 to 12000	n = 1 to 1000
Node!@GV.DSCI2(n)	VT_BOOL	Modbus Address 12001 to 13000	n = 1 to 1000
Node!@GV.DSCI3(n)	VT_BOOL	Modbus Address 13001 to 14000	n = 1 to 1000
Node!@GV.DSCI4(n)	VT_BOOL	Modbus Address 14001 to 15000	n = 1 to 1000
Node!@GV.DSCI5(n)	VT_BOOL	Modbus Address 15001 to 16000	n = 1 to 1000
Node!@GV.DSCI6(n)	VT_BOOL	Modbus Address 16001 to 17000	n = 1 to 1000
Node!@GV.DSCI7(n)	VT_BOOL	Modbus Address 17001 to 18000	n = 1 to 1000
Node!@GV.DSCI8(n)	VT_BOOL	Modbus Address 18001 to 19000	n = 1 to 1000

● **IREG (30001 to 39000)**

Read only. Writing through the OPC interface does not cause an error, but nothing can be written onto the Modbus area of ASGW/ASIU. Unmapped address data is always read as “0”.

OPC Data Name	OPC Data Type	Function	Remark
Node!@GV.IREG0(n)	VT_UI2	Modbus Address 30001 to 31000	n = 1 to 1000
Node!@GV.IREG1(n)	VT_UI2	Modbus Address 31001 to 32000	n = 1 to 1000
Node!@GV.IREG2(n)	VT_UI2	Modbus Address 32001 to 33000	n = 1 to 1000
Node!@GV.IREG3(n)	VT_UI2	Modbus Address 33001 to 34000	n = 1 to 1000
Node!@GV.IREG4(n)	VT_UI2	Modbus Address 34001 to 35000	n = 1 to 1000
Node!@GV.IREG5(n)	VT_UI2	Modbus Address 35001 to 36000	n = 1 to 1000
Node!@GV.IREG6(n)	VT_UI2	Modbus Address 36001 to 37000	n = 1 to 1000
Node!@GV.IREG7(n)	VT_UI2	Modbus Address 37001 to 38000	n = 1 to 1000
Node!@GV.IREG8(n)	VT_UI2	Modbus Address 38001 to 39000	n = 1 to 1000

● **HREG (40001 to 49000)**

Read/write is possible. Writing data onto unmapped areas is ignored. Do not write data onto the DSCI-mapped address since the DCS may read wrong values until ASGW/ASIU reads the next data from devices. Unmapped address data is always read as “0”.

OPC Data Name	OPC Data Type	Function	Remark
Node!@GV.HREG0(n)	VT_UI2	Modbus Address 40001 to 41000	n = 1 to 1000
Node!@GV.HREG1(n)	VT_UI2	Modbus Address 41001 to 42000	n = 1 to 1000
Node!@GV.HREG2(n)	VT_UI2	Modbus Address 42001 to 43000	n = 1 to 1000
Node!@GV.HREG3(n)	VT_UI2	Modbus Address 43001 to 44000	n = 1 to 1000
Node!@GV.HREG4(n)	VT_UI2	Modbus Address 44001 to 45000	n = 1 to 1000
Node!@GV.HREG5(n)	VT_UI2	Modbus Address 45001 to 46000	n = 1 to 1000
Node!@GV.HREG6(n)	VT_UI2	Modbus Address 46001 to 47000	n = 1 to 1000
Node!@GV.HREG7(n)	VT_UI2	Modbus Address 47001 to 48000	n = 1 to 1000
Node!@GV.HREG8(n)	VT_UI2	Modbus Address 48001 to 49000	n = 1 to 1000



**NOTE**

Although the input relay and input register are read-only data, they are not write protected in the OPC interface. They should be engineered so that they are write protected from the OPC client application. Otherwise, if ASGW/ASIU is connected to DCS, the value of input relay or input register that has been accidentally written via the OPC interface may be read by the DCS.

# 7. ARCNET

The New ARCNET-based bus system enables connection between an ARCNET system and an Ethernet system. This realizes addition of Ethernet analyzers to existing ARCNET systems.

A typical network configuration of analyzer bus is shown in Figure 7.1.

The network consists of analyzers (Gas chromatograph etc.) and "Analyzer bus systems for ARCNET". This "Analyzer bus systems for ARCNET" consist of "Gateway unit", "analyzer server" and "ARCNET / Ethernet Converter".

Each software (PCAS, ASET) for "Analyzer server" and "Analyzer Server Engineering Terminal" should be used ARCNET edition "/ARC".

The communication to the analyzer connected to Ethernet is also enabled.

- "Analyzer bus systems for ARCNET" should be used so that DCS communicates with analyzer connected to ARCNET.
- Redundancy for ARCNET is enabled. Redundancy for Ethernet can be done by using double "Analyzer bus systems for ARCNET".
- One "Analyzer bus systems for ARCNET" can communicate with up to 30 sets of analyzers connected to ARCNET. In case of communicating with more than 31 sets, plural number of "Analyzer bus systems for ARCNET" should be used.

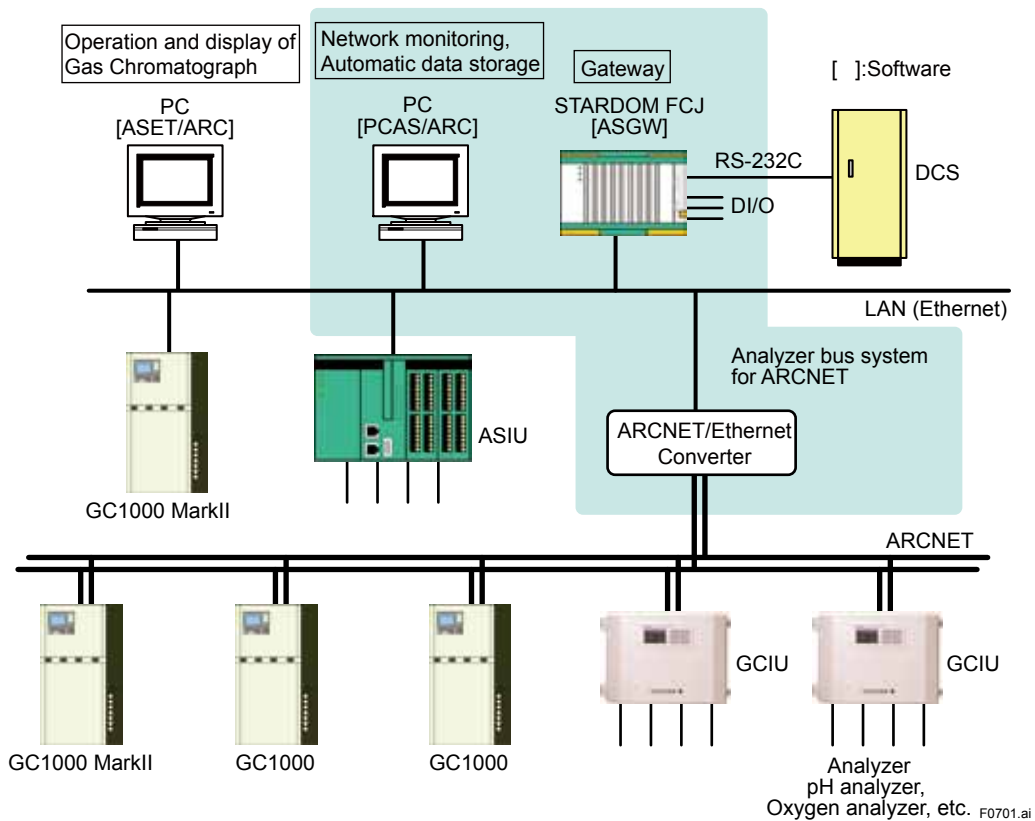

Figure 7.1 Typical System configuration

# 8. Troubleshooting

## 8.1 Install

Phenomena	Cause	Countermeasure
Fail to copy the data into the system disk when installing.	Invalid of attribution of the property of JEROS_AP folder.	Un-click "Enable to archive the folder" at the archive attribution of JEROS_AP folder.

## 8.2 Diagnostic window (Web browser)

Phenomina	Cause	Countermeasure
Diagnostic window can not be opened.	No HTML file. The copy of the file is not created.	Re-install *1
Diagnostic window can be opened but the check window of the mapping file does not come up.	Java application is not in operation. The file copying is not success.	Re-install *1
	No setting of Java is in operation. No license of Java is installed.	Check the license of Java.
"TASK" is not OK on the Modbus status window.	Modbus TCP Client is not in operation. No license of Modbus is installed.	Check the license of Modbus.

\*1: Re-install has to be executed after ASGW\_MAP.CSV file is deleted.



---

# Revision Information

- Title : ASGW Analyzer Server Gateway Software
- Manual No. : IM 11B06E01-01E

## **Aug. 2006/1st Edition**

Newly published

## **Jan. 2007/2nd Edition**

4.2.3 Addition of the value in range.  
Addition of "6. OPC DA 2.0 Interface".

## **Jun. 2011/3rd Edition**

Added the upgraded specifications.

P.1-1 modified chapter 1, P.3-1 to 3.4 modified item 3.2 to 3.4, P.4-3 added (5), (6), P.4-4 changed "Example of mapping file", P.4-5 added "Example of mapping file (include ARCNET)", P.4-6 added NOTE and "#TSET, StnID", P.4-7 added TIP and "Specifying DO output", P.4-8 added item 4.2.6, P.4-14 added TIP and item 4.3.3, P.6-1 added item 6.4, P.6-2 modified item 6.5, and Chapter 7 Corrected License Codes (P.2-1) and GS number (P.3-4).

## **Nov. 2011/4th Edition**

Revised for "GC8000".