

## Introduction

Thank you for your purchase! Based on Eagle Tree's proven inertial stabilization technology, the Guardian 2D/3D Stabilizer (the Guardian) stabilizes most types of fixed wing models, and works with most any radio. Unlike most "gyro stabilizer" products on the market, when configured correctly the Guardian provides true wing leveling stabilization as well as precise fly-by-wire control. This lets you configure the Guardian to return to level flight in an emergency, by just flipping a radio switch!

## Read the Manual!

This manual contains important instructions related to safety. Read the entire manual before proceeding, to become familiar with the features and operation of the Guardian. Failure to correctly configure or operate the Guardian could cause damage to personal property or serious injury! The latest version of this manual is available in the Product Manuals section of the Support tab on <http://www.eagletreesystems.com>. The online manual is in full color, and includes any updates that were made after this manual was printed. If, after you read the manual, you have further questions or problems, see the "How to Get Help" section below.

## Packing List

Your package should include the following: The Guardian, the receiver connection harness with labeled connectors, the quick reference card, and a printed version of this manual.

## Specifications (approximate)

- Input Voltage Range: 4.5v to 16v
- Current Draw: Approximately 31mA
- Dimensions: 41mm x 22mm x 11mm (1.62 inches x 0.86 inches x 0.42 inches)
- Mass: 11 grams (0.4 ounces) including harness
- Maximum Servo Current through Guardian: 5 Amps
- Recommended Airframes: the Guardian is not recommended for large or heavy airframes, due to no or limited testing on these types of models at this time.

## How to Get Help

Eagle Tree is committed to providing great customer service. If you've read the manual and something is not clear, just ask. We'd much prefer to take the time to answer your questions, rather than having you waste your valuable time struggling with an issue.

To get help, visit the Eagle Tree Guardian support thread at <http://www.rcgroups.com/forums/showthread.php?t=1596644>. Chances are someone has posted a solution to your problem already. If not, posting your problem there will get a very quick response from the Eagle Tree community.

If you prefer to not post on the forum, or you feel there is a problem with your Eagle Tree hardware, please open a support ticket with us at <http://ticket.eagletreesystems.com> and we will respond to your support ticket as soon as we can. Note that when you create a support ticket, you will be emailed a link that will let you check the status of the ticket. If you do not receive the email, this most likely means that a spam filter is intercepting emails from Eagle Tree.

Also Eagle Tree greatly values your feedback on how we can improve our products. To leave us feedback for a new feature request or improvement, either post the feedback on our support thread above, create a support ticket with your feedback, or just email us at [support@eagletreesystems.com](mailto:support@eagletreesystems.com).

## Terms and Symbols used in the Manual



**Warning that could affect safety or result in injury, a crash, property damage or Guardian hardware damage if not heeded.**



**Helpful Note**

**Pitch** – Lift or descent of the nose and tail of the model. Normally controlled by the elevator, or movement of elevons in same direction.

**Roll** – Rocking movement of the wings, side to side. Normally controlled by ailerons, or movement of elevons in opposite directions.

**Yaw** – Turning of the airplane without banking. Normally controlled by the rudder.

**Axis** – an imaginary line drawn horizontally through your model's wing (for Pitch), horizontally through your fuselage (for roll), or vertically through the center of your fuselage (for yaw).

**Control Stick** – The stick on your radio that controls elevator and aileron functions (pitch and roll).

**Attitude** – The orientation of the model with respect to the horizon.

**2D Mode** – A mode where the model is brought to a level attitude (level flight and level wings) by the Guardian when the control stick is centered.

**3D Mode** – A mode where the Guardian attempts to hold the model's present attitude when the Control Stick is centered, by moving the model's control surfaces automatically.

**Heading** – The present direction of travel of the model with respect to North.

## Table of Contents

- Introduction 1
- Specifications (approximate) 1
- How to Get Help 1
- Terms and Symbols 1
- General Safety Precautions 2
- Main Features 2
- Overview/Quick Start 2
- Guardian Physical Connections/ Controls 3
- The Receiver Connection Harness 4
- Configuring the Mode and Gain Channels 4
- Receiver Requirements 5
- Mounting the Guardian in your Model 6
- Preflight Checks 6
- First Flight 6
- Tuning Stabilization Gains 7
- Status LED 8
- Mode/Config Switch Behavior 9
- The Guardian PC Software 11
- Guardian Configuration Page Software Reference 12

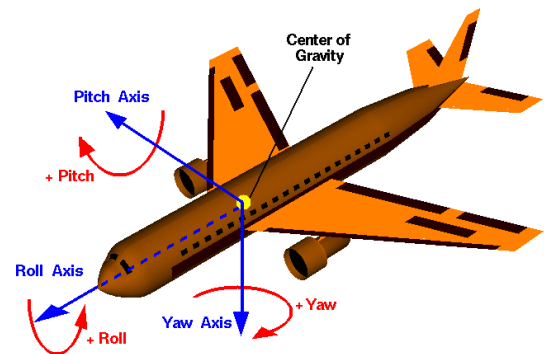

**Control Surfaces** – Your model’s elevator, ailerons (or elevons) and rudder (if equipped).

**Receiver Connection Harness** – The cable included with your Guardian that lets you connect your Guardian to your receiver’s outputs.

**Mode/Config Switch** – A two or three position switch on your radio transmitter which you have configured to control the “Mod” input on the Guardian’s Receiver Connection Harness.

**Toggle** – One fairly rapid movement the Mode/Config Switch between its extents. (UP/DOWN or DOWN/UP)

**Configuration Gestures** – A series of toggles of the Mode Config/Switch. The number of times you toggle the switch determines which configuration step is performed.

**Gain Knob** – A knob or switch on your radio transmitter which you have configured to control the “Gain” input on the Guardian’s Receiver Connection Harness.

## **General Safety Precautions**

In addition to other warnings and other precautions in this manual, the following should always be observed:

- 1) The Guardian is intended for recreational use only! Any other use is not supported.
- 2) Fly safely! Please refer to the American Model Association’s Safety Code at <http://www.modelaircraft.org/files/105.PDF>, or the appropriate safety code for your country. Always obey the law when flying.
- 3) If you have never set up or operated an RC model before, you will need help from an experienced modeler. Local RC clubs are great ways to meet experienced modelers, and receive the required training.
- 4) Never operate your model aircraft near or over buildings, power/telephone lines, or other obstacles. Never operate your model aircraft near or over yourself or other people!
- 5) RC models and accessories are not toys, and should be kept away from children, without proper adult supervision.
- 6) Be sure to always fly conservatively and exercise common sense!

## **Main Features**

The Guardian 2D/3D Stabilizer has two main modes of operation: 2D Mode and 3D Mode. While in flight, a spare switch on your radio lets you switch between 2D mode, 3D aerobatic mode, and no stabilization. Imagine performing a difficult 3D maneuver with ease, then just flipping a switch to instantly return to level flight!

 **Please see the Tuning Stabilization Gains section for notes on preventing damage from re-leveling too quickly.**

### **2D Mode**

When set for 2D Mode, the Guardian provides much smoother flight and wing leveling stabilization for your model, which makes it a lot easier to adjust and fly your plane. In this mode, the Guardian “remembers” level flight for your model and returns it to level flight when needed. In 2D mode, flying in moderate wind can seem just as easy as flying in no wind at all!

Additionally, the Guardian provides precise “fly by wire” control, in which it interprets your control stick deflections as command angles for Pitch and Roll. For example, pushing and holding your control stick left will cause your model to enter a level altitude banked left turn. This mode is ideal for beginners as well as experts looking for a reduced workload on take-off and landing. It also can be useful for aerobatic pilots seeking to recover quickly after losing orientation.

The Guardian also includes an advanced “Oscillation Suppression” feature that can quickly detect and eliminate oscillations stemming from too high gains.

### **2D Heading Hold Submode**

With 2D Heading Hold submode, the Guardian will assert Aileron deflections to keep your model locked on its current 2D heading. Whenever the control stick is moved to turn, this heading is reset and subsequently relocked as soon as the stick is centered again.

### **Automatic Turn Coordination**

When enabled, Automatic Turn Coordination will cause the Guardian to employ the “step on the ball” method of actuating your Rudder for you. As you enter a banked turn, the Guardian will assert a coordinating response on the Rudder automatically. This deflection is completely based on the side-to-side g-force measured by the Guardian and does not introduce any movement on the Ailerons. This mode is great for models that skid easily.

 Expected behavior here is that on the bench, the Guardian will introduce a Rudder movement that will yaw the model towards the direction it is being rolled. For instance, if a stationary plane is rolled to the right, the Rudder should assert a right yaw moment to follow the detected turn.

 Since this is based on horizontal g-force, the Guardian may exhibit different behavior in the air in a “skid” condition where the model is moving one direction, but pointing another. The Automatic Turn Coordination will work to point the model in the direction that it is moving through the air in this case.

### **3D Mode**

In 3D Mode, the Guardian works to smooth out turbulence and stall characteristics to bring stability and precision to your model while leaving the feel of flying the same as without stabilization. This mode is intended for more advanced pilots looking for improved stability without compromising on performance and feel.

### **3D Heading Hold Submode**

Centering the control stick in 3D Mode will engage 3D Heading Lock, which will cause your airplane to hold its present flight orientation (assuming it is aerodynamically able to do so). In this mode, when the control stick is centered the Guardian remembers its current Pitch, Roll and Heading and works to keep those locked. Moving the control stick immediately resets the locked heading, allowing for instantaneous transitions from locked maneuvers to dynamic flight. Actuation of the Rudder control will reset just the Yaw axis, without affecting the lock on Pitch and Roll.

### **Direct Rate 3D Control Submode**

Unlike many other gyro stabilization systems, the Guardian employs Direct Rate 3D Control to translate your stick deflections to angular rates without forcing you to “fight the gyro.” With this feature enabled, the Guardian interprets your stick deflections as commanded angular rates and attempts to have your model follow those commands. This way, snap rolls and other high speed maneuvers are possible without compromising on stabilization effects.

## **Overview/Quick Start**

First, read through the manual to get a “big picture” understanding of mounting, connection, configuration and operation of the Guardian.

 Consider watching the Guardian tutorial video located at <http://youtu.be/Rt8Y3Lxnv-0>.

While the Guardian has a wealth of configurable features and options, getting in the air for most airframes requires minimal setup and configuration. At a minimum, the Guardian should be connected between your receiver and your servos and then told some basic orientation and trim details of your model. These steps are detailed as follows. Note: it is assumed here that you have a transmitter switch connected to the Guardian’s Mode/Config input.

- **Connect the Guardian to your receiver using the included servo wire harness.** Refer to the *Receiver Connection Harness* section for more information.

- **Connect your servos to the matching servo output channels on the Guardian.** Note that the servo connectors' signal wires should be on top when the Guardian's label is facing the sky. See the *Wing Type Configuration* section for details on specific airframes.
- **To reduce the possibility of extreme servo deflection, it is recommended that you disable stabilization during initial setup.** There are 3 ways to disable stabilization:
  - If you are using a 3 position Mode/Config switch, move it to the center (disabled) position.
    - ☞ The Guardian's LED should be OFF when in the Mode/Config switch is in the disabled position.
  - If you are controlling overall Guardian gain with a knob on your transmitter, set your Gain dial to -100% servo deflection (~1.1ms pulse length) to disable stabilization.
  - If neither of these methods is applicable, turn the Pitch/Roll/Yaw dials on the Guardian to their centered position, which will also disable stabilization.
- **Configure your Guardian and transmitter for your wing type** (see the *Wing Type Configuration* section for more information):
  - Turn off Elevon and V-Tail mixing in your transmitter, if it is enabled. Elevon and V-Tail mixing will be done by the Guardian.
  - By default, the Guardian is programmed for traditional wing types (mixing disabled). If your model requires elevon or V-Tail mixing, you can quickly enable this feature by doing the following:
    - Within 15 seconds of powering on, toggle your Mode/Config switch **three times**, which is the *Toggle Elevon Mixing* switch gesture (move the switch up-down-up-down-up-down if the switch is presently down, or down-up-down-up-down-up if the switch is presently up).
    - Your servos should "twitch" **three times** to indicate that you have toggled elevon mixing ON/OFF.
    - Move your control sticks to ensure that the mixing is now enabled. If not, you may need to re-run the Enable Elevon Mixing step.

**⚠ Configuring the wing type correctly is critical! The model will not be controllable in the air if the wing type is incorrect.**

- **Place your plane on a test bench so its orientation is the same as it would be during straight and level flight.**
- **Reset your Trims and Level Flight Orientation:**
  - Within 15 seconds of powering on, and with your plane still in the orientation of level flight, toggle your Mode/Config switch **once**, which is the *Reset Level Flight and Trims* switch gesture. Your servos should "twitch" **once** to indicate that you have reset your controller trims and level flight orientation.
    - ☞ Any time you re-trim your plane or re-mount the Guardian, you will need to do this again to ensure best stabilization performance.
- **Compensate for servo directions and throws:**
  - Set your Mode/Config switch to -100% (switch position 2 on a Spektrum™ controller). This activates "2D Mode".
    - ☞ The Guardian's LED should be blinking on and off repeatedly, which indicates 2D Mode.
  - Turn up the Overall Gain knob on your transmitter its center position (100% overall stabilization gain) if you are using the gain knob.
  - Observe how your servos react as you pitch, roll and yaw your plane.
  - Adjust the Guardian Pitch, Roll and Yaw axis dials with a screwdriver, so the servo for each axis deflects in the correct direction to bring your model back to level. A centered dial asserts zero stabilization on that axis. Turning it clockwise or counterclockwise increases the gain and selects the servo stabilization direction. See Figure 6 to see which directions your surfaces should move as you move your model.
- **Ensure your Transmitter's elevator and aileron endpoints are set for +/-100%, if applicable.** The Guardian expects full ranges when it interprets your command stick deflections to determine the desired orientation in 2D Mode.
- **Preflight:**
  - Check that when you pitch, roll and yaw your plane while in either 2D or 3D Mode, that your servos oppose your movements. See Figure 6 in the *Preflight Checks* section for more information.

**⚠ If the control surfaces are not correctly set up to move in the appropriate directions to counteract pitch, roll and yaw movements, it could result in a crash!**

- Do an engine run-up and confirm that the control surfaces are not moving around randomly due to excessive vibration or a loosely mounted Guardian.

**⚠ If the control surfaces are moving on their own during run-up, this could result in a crash! Do not fly if this is the case.**

- Range check your model!

## Guardian Physical Connections/ Controls

Please refer to Figure 1. The Guardian has the following physical connections and controls:

- Port for Receiver Connection Harness – this is where the included harness connects. The servo plugs on the harness then connect to the appropriate receiver channels. Please see the *Receiver Connection Harness* section below for more information.
- Servo Connection Ports – connect the appropriate servos to the Guardian here, noting the plug orientation in Figure 1. Please see the *Wing Hookup Configurations* section below for more information.
- Yaw, Roll and Pitch gain control dials – these dials set the individual gains for the Yaw (Rudder), Roll (Aileron) and Pitch (Elevator) axes, as well as setting the direction of stabilizing servo travel, and are adjusted with a small screwdriver. Please see the *Tuning Stabilization Gains* section for more information.
- Micro USB port – this port accepts a "Micro B" USB cable (not included). Connection to a PC lets you update the Guardian firmware, and also configure and tune your Guardian via your PC. Please see the *PC User Interface* section for more information.

**⚠ Do not apply upward force on the USB connector when a cable is inserted! Doing so can damage it.**

- Accessory (Data) Port – this port is for future expansion, and is not used presently. Please let us know how we should use this port!
- LED Viewports – for your convenience, the status LED can be seen from both the top and side of the Guardian case. Please see the *Status LED* section for more information.

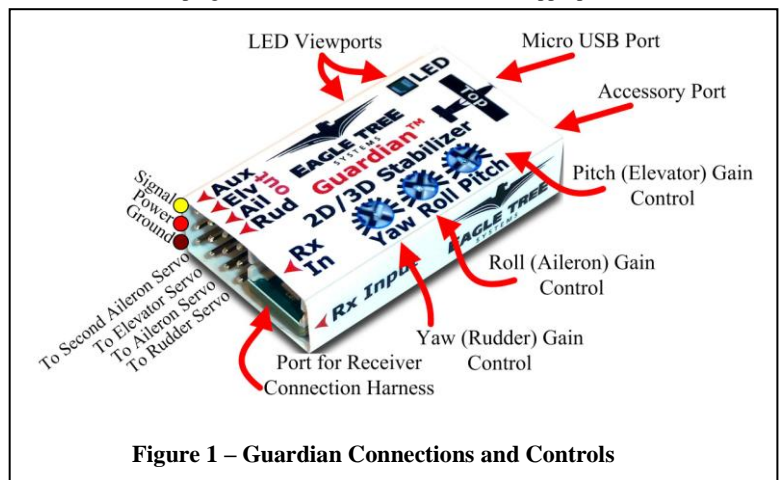

**Figure 1 – Guardian Connections and Controls**

## The Receiver Connection Harness

### Receiver Connection Harness Pinout

The lightweight receiver connection harness with labeled connectors should make it easy for you to hook up the Guardian to your receiver.

A diagram of the harness is shown in Figure 2, for your reference. It has the following labeled receiver connections:

- **Ail** – (required) Connects to your receiver’s Aileron output channel. Note that this channel also supplies power and ground to the Guardian and the servos connected to the Guardian.
- **Elv** – (required) Connects to your receiver’s Elevator output channel
- **Rud** – (optional) Connects to your receiver’s Rudder output channel
- **Aux** – (optional) Connects to your receiver’s Second Aileron or Flaperon output channel, if needed
- **Mod** – (optional, recommended) The Mode/Config input connects to either a two-position or three-position switch. It allows you to switch the Guardian mode during flight and to do radio stick configuration of the Guardian. See the *Mode/Config Switch Behavior* section for more information.
- **Gain** – (optional) The Gain input connects to a knob (or slider) on your receiver, and lets you adjust the overall stabilizer gain during flight. See the *Stabilization “Master Gain” Control* section for more information.

### Receiver Connection Harness Load Capacity

When connected typically, the Aileron lead of the Guardian’s receiver connection harness takes power from your receiver, and this powers the servos you have connected to the Guardian. The Receiver Connection Harness is easily capable of handling the power requirements of typical analog and digital servos.

**⚠ However, if the servos you have connected to the Guardian are very large, and/or have a combined current draw of greater than 5 amps, an additional power cable is required.** Note that if your BEC or receiver battery is rated at 5 amps or less (the vast majority are), a backup cable should not be needed. Note also that the Aileron lead of the harness should not be excessively warm after flying, which could indicate that backup power is needed.

If the servos you have connected to the Guardian draw greater than 5 amps all together, there are two ways to supply additional power to your servos, which will provide additional current carrying capability to the servos you have connected to the Guardian:

- 1) If you are not using all the servo output connections on your Guardian, a male to male servo wire (with the signal line cut!) can be connected between a free servo channel on the Guardian, and a free channel on your receiver.
- 2) If all the servo connections on the Guardian are being used, a male/male/female Y cable (ET p/n CAB-Y-1 or similar) with the signal line cut can be used to provide additional power to the servos, as shown in Figure 3.

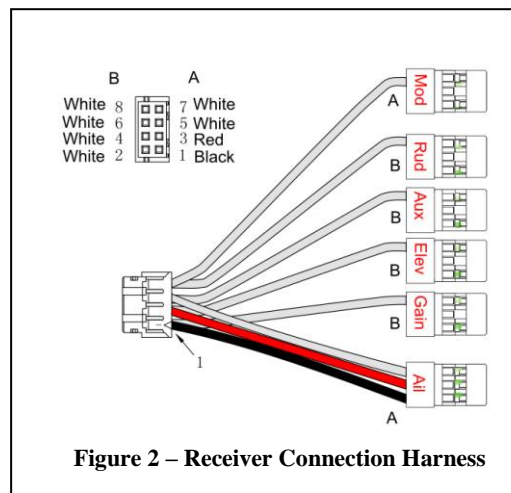

Figure 2 – Receiver Connection Harness

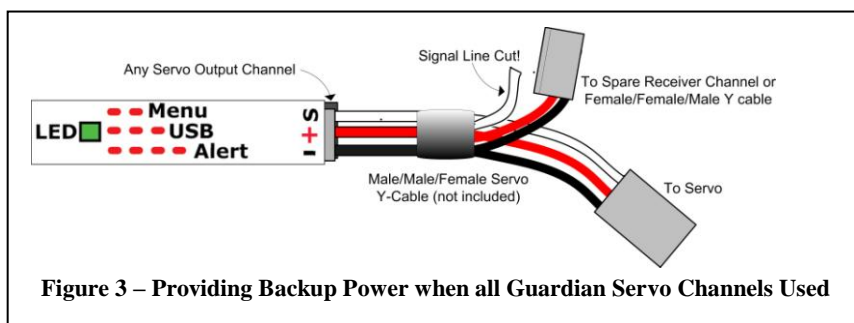

Figure 3 – Providing Backup Power when all Guardian Servo Channels Used

### Configuring the Mode and Gain Channels

For best results, we recommend that the Mode/Config input wire (labeled Mod) on the receiver connection harness be connected to a channel on your receiver that is controlled by a 2 or 3 position switch. If you have problems getting this to work, you can test the switch temporarily by connecting a servo to the channel on your receiver that is controlled by it. Then, move the switch. If it has 2 positions, you should see the servo move from one extent to the other. If it has 3 positions, you should see the servo move from one extent, to center, and to the other extent.

Once you confirm this, reconnect your Mod wire to that channel. If using a 2 position switch, the Guardian will then be able to be switched between 2D and 3D Mode. If using a 3 position switch, the Guardian will be able to be switched between 2D, off, and 3D. If you want to use the Guardian with a 2 position for 2D and off, you will need to reduce one endpoint for that channel (if your transmitter is capable of adjusting endpoints) so that in one position the Guardian’s LED blinks, and in the other position it stays off.

If you have an additional free channel that can be controlled by a slider or knob, you can use this channel to remotely change the Overall Gain on the Guardian, by connecting that channel to the Gain wire on the receiver connection harness. In order to test this slider or knob, temporarily connect a servo to the channel on your receiver that is controlled by the knob/slider. Then, move the knob/slider. You should see the servo move from one extent to the other as you operate the knob/slider.

### Performing Reset Level Flight and Trims

Assuming you are using a Mode switch, you will want to power the system on with the switch in the 2D or 3D Mode position. Then, within 15 seconds of powering on the system, move the switch to the opposite position and back to the original position quickly. The control surfaces will twitch once to indicate level flight and trims has been set.

The meaning of each switch position can be custom defined through the PC software. See *The Mode Config Tab* in the *The Guardian Configuration Page Software Reference* section of this manual, for more information.

If you need more detailed information about programming your specific radio, it is suggested to refer to your radios operating manual. Otherwise, you may want to check the Guardian thread on rcgroups.com to see if someone else is using the same setup you are. The thread is located here; <http://www.rcgroups.com/forums/showthread.php?t=1596644>

### Performing Reset Level Flight in the Air

Sometimes, the most accurate way to record level flight is when your model is in the air, flying straight and level. Fifteen seconds after initial power-on, the Guardian will enable a 5-toggle gesture that will record the current pitch and roll before storing it as the new level flight orientation.

The recommended method to best utilize this feature is to enable 2D Heading Hold. Given a little time to settle out, the 2D Heading Hold should make the model fly very straight, allowing you to focus on just controlling altitude with the Elevator stick. Once the model is flying straight and level, perform the 5-toggle gesture. Upon completion, the orientation that the model was in at the beginning of the toggle gesture will be used as the new level flight orientation.

 The current pitch and roll are recorded every time the Mode switch is transitioned out of a 2D-Mode position at the beginning of a toggle gesture. Once the 5-toggle gesture is completed, those recorded pitch and roll values are stored to permanent memory as the new level flight orientation. If the 5-toggle gesture does not complete within the standard time-out (1 second per toggle), then the recorded orientation information is discarded and no changes are made.

## Receiver Requirements

### Receiver Connection Requirements

The number of connections between the Guardian and your receiver depends on type and capabilities of your model, the level of Guardian in-flight control you require, and the number of spare receiver channels you have. For very basic models, the Guardian is capable of operating with only the Elevator input and Aileron input connected.

### BEC/Receiver Battery Power Requirements

The Guardian 2D/3D Stabilizer is sensitive to deep voltage drops, which means that **your BEC or receiver battery must be sufficient to maintain a voltage of at least 3.5 volts, even under full servo load. The Guardian will shut off if the voltage drops below this level! Under normal conditions, the BEC voltage should be at least 4.5 volts to achieve the best stabilization performance. Never exceed 16V!**

If the voltage drops below 3.5 volts for a short period of time, the Guardian will experience a “brownout.” In this case, the Guardian will attempt to recover gracefully. During recovery, stabilization may be disabled or suffer from performance issues while it does so.

 **If you experience issues like this in flight, bring the Mode/Config Switch to either 3D Mode or Stabilization Disabled Mode (if your transmitter is configured for mode control) and land immediately.**

 If a brownout condition is detected by the Guardian, the LED will blink an error code of four long blinks followed by one short blink. If this LED signal is ever seen after a flight, it is recommended that the BEC or battery be upgraded. Please see the *Status LED* section for more information on how to interpret LED blinks.

### Failsafe position of Receiver Inputs

 If, after you reset level flight and trims, an input channel should become disconnected from your receiver during flight, it will cause the Guardian to use the stored trim setting for that servo channel input as a failsafe.

### Functionality Limitations without the Mode and Gain Inputs or the PC Connection

While the Guardian is capable of flying without the Mode or Gain inputs being connected, most configuration steps need either the Mode input or a PC connection in order to be done correctly. The Guardian comes preconfigured for standard fixed wing flight. Configuring the Guardian any other way will need to be set up using either the Radio Stick Menu, which is activated using the Mode switch, or the PC Software, which requires a USB connection. Either the Mode Input or a PC is needed to Reset Level Flight and Trims as well.

In the case where neither of these is available, it is recommended that you remap an unused channel, such as Throttle or Rudder to the Mode Input temporarily to emulate a Mode Switch. Next, ensuring that your controller’s servo ranges for that channel are set to 100%, the remapped channel can be used to enter the Radio Stick Menu.

While the Radio Stick Menu will allow most configurations, it is only possible to access some features through the PC Software. These include the AHI display, saving and reloading past configurations and the ability to limit your Servo Deflections (available under the Servo Config tab).

## Wing Type Configuration

The Guardian is configurable for most common wing types. By default, it is configured for traditional wing control. Please refer to Figure 4, which shows the receiver and servo connections for typical wing types.

<p><b>Traditional Models with Single Aileron Servo</b></p> <ul style="list-style-type: none"> <li>• <i>Model Control Type</i> setting: Standard (this is the default)</li> <li>• Guardian Receiver Inputs <ul style="list-style-type: none"> <li>○ Receiver Aileron Output → Guardian Aileron In</li> <li>○ Receiver Elevator Output → Guardian Elevator In</li> <li>○ Receiver Rudder Output → Guardian Rudder In</li> <li>○ Guardian Aux-In is not connected</li> </ul> </li> <li>• Guardian Servo Outputs <ul style="list-style-type: none"> <li>○ Guardian Aileron Out → Aileron Servo (<i>if no Aileron present, connect Rudder Servo to Aileron Out</i>)</li> <li>○ Guardian Elevator Out → Elevator Servo</li> <li>○ Guardian Rudder Out → Rudder Servo</li> <li>○ Guardian Aux Out is not connected</li> </ul> </li> </ul>	<p><b>Traditional Models with Dual Aileron/ Flaperon servos (with Transmitter mixing)</b></p> <ul style="list-style-type: none"> <li>• <i>Model Control Type</i> setting: Standard (this is the default)</li> <li>• Guardian Receiver Inputs <ul style="list-style-type: none"> <li>○ Receiver Aileron Output → Guardian Aileron In</li> <li>○ Receiver Elevator Output → Guardian Elevator In</li> <li>○ Receiver Rudder Output → Guardian Rudder In</li> <li>○ Receiver Second Aileron or Flaperon Output → Guardian Aux In</li> </ul> </li> <li>• Guardian Servo Outputs <ul style="list-style-type: none"> <li>○ Guardian Aileron Out → Aileron Servo</li> <li>○ Guardian Elevator Out → Elevator Servo</li> <li>○ Guardian Rudder Out → Rudder Servo</li> <li>○ Guardian Aux Out → Second Aileron or Flaperon Servo</li> </ul> </li> </ul>
<p><b>V-Tail with Ailerons</b></p> <ul style="list-style-type: none"> <li>• <i>Model Control Type</i> setting: V-Tail</li> <li>• Guardian Receiver Inputs <ul style="list-style-type: none"> <li>○ Receiver Aileron Output → Guardian Aileron In</li> <li>○ Receiver Elevator Output → Guardian Elevator In</li> <li>○ Receiver Rudder Output → Guardian Rudder In</li> <li>○ Receiver Second Aileron Output → Guardian Aux In (optional)</li> </ul> </li> <li>• Output <ul style="list-style-type: none"> <li>○ Guardian Aileron Out → Aileron Servo</li> <li>○ Guardian Elevator Out → V-Tail Servo 1</li> <li>○ Guardian Rudder Out → V-Tail Servo 2</li> <li>○ Guardian Aux Out → Second Aileron Servo (optional)</li> </ul> </li> </ul>	<p><b>Elevon / V-Tail with no Ailerons</b></p> <ul style="list-style-type: none"> <li>• <i>Model Control Type</i> setting: Elevon</li> <li>• Guardian Receiver Inputs <ul style="list-style-type: none"> <li>○ Receiver Aileron Output → Guardian Aileron In</li> <li>○ Receiver Elevator Output → Guardian Elevator In</li> <li>○ Receiver Rudder Output → Guardian Rudder In</li> <li>○ Guardian Aux-In is not connected</li> </ul> </li> <li>• Output <ul style="list-style-type: none"> <li>○ Guardian Aileron Out → Elevon Servo 1</li> <li>○ Guardian Elevator Out → Elevon Servo 2</li> <li>○ Guardian Rudder Out → Rudder Servo</li> <li>○ Guardian Aux Out is not connected</li> </ul> </li> </ul>

**Figure 4: Receiver and Servo Connections for Typical Wing Types**

 **The Guardian requires unmixed control inputs from your receiver, even if you have a V-Tail or Elevon model.** If you have a V-Tail or Elevon model, the Guardian does the mixing internally, so you will need to change your transmitter configuration to standard wing type, rather than having your transmitter do the mixing.

 For airframe types other than standard and dual Aileron/Flaperon, you will need to be change the “Model Control Type” setting, using either the radio stick configuration or the PC software. See the *Menu Operation* section below for more information on changing this setting.

### Dual Ailerons/Flaperons

An exception to the unmixed input requirement is made for Dual Aileron and Flaperon models. By default, the Guardian will accept premixed Dual Aileron or Flaperon inputs to its Aileron and Aux inputs. But, if your controller does not have the capability of performing Dual Aileron or Flaperon mixing, then the Guardian can be configured to do this for you. See the *List of Features and Options: Onboard Dual Aileron Mixing Enabled* menu option for more information.

### Mounting the Guardian in your Model

Please refer to Figure 5, which indicates correct and wrong Guardian mounting.

 **Make sure you are mounting the Guardian in one of the correct ways shown below! The Guardian will not work correctly otherwise!**

Mount the Guardian securely with two sided servo tape, Velcro, or similar, so that it is in line with your direction of flight. It should be mounted near the model’s center of gravity and level to the horizon when your plane is flying straight and level, but the Guardian will compensate for small mounting errors.

Choose a mounting location which will allow the Guardian to be easily connected to your receiver and servos.

 **If the Guardian comes loose from its mounting location during flight, it will not be able to correctly stabilize your model! After mounting, be sure to pull up on the Guardian with a force greater than you expect to encounter in flight, to confirm mounting integrity.**

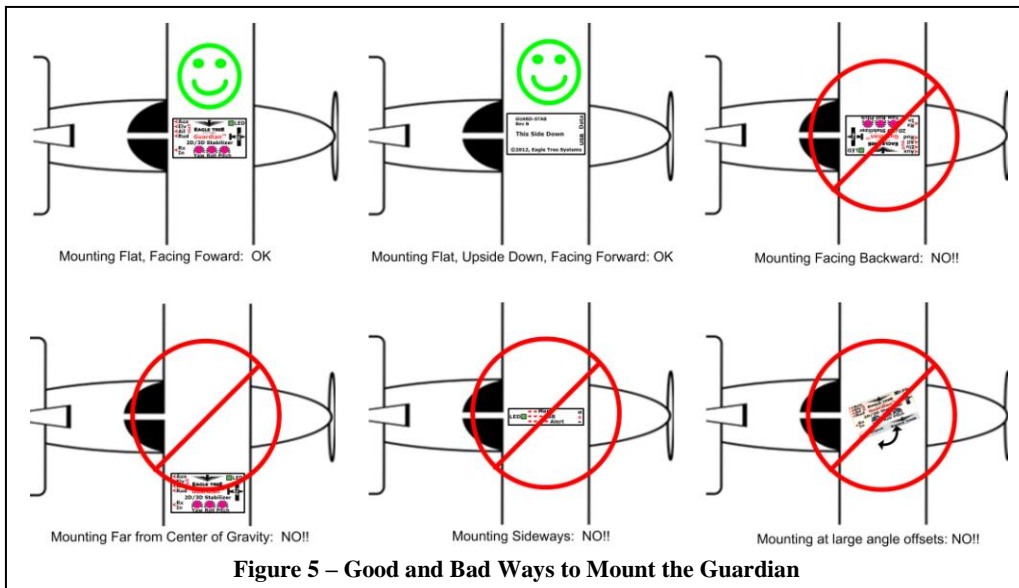

**Figure 5 – Good and Bad Ways to Mount the Guardian**

 If permanently mounting the Guardian, ensure that the USB port is still accessible for PC configuration and firmware update.

### Preflight Checks

Before every flight, it is strongly recommended that you perform the following steps:

- Perform your normal preflight check. Ensure your servos respond correctly to your RC control stick commands.
- To test that the Guardian is working, hold the airplane level. Now, pitch, roll and yaw the model. Please see Figure 6. You should see the control surfaces deflecting appropriately to level the airplane and keep it on a straight heading. If the control surfaces do not move at all, ensure that the Master Gain knob on your transmitter (if used) is set so that stabilization will occur, and ensure that the Mode/Config switch (if used) is set for either 2D or 3D Mode.
- If either 2D or 3D Heading Hold is enabled, be sure to reset the locked direction of flight just before takeoff by moving the Aileron stick.

 **If any of your control surfaces are moving the wrong direction, you need to reverse the direction of the appropriate Guardian Gain Control Dial!**

### First Flight

To account for trims and mounting errors of the Guardian within your plane, follow the instructions in the section titled “Reset Level Flight and Trims.”

On your first flight, it is recommended that you do an unpowered hand-toss of your airplane, if it is capable of hand-toss launches. If the airplane safely glides to the

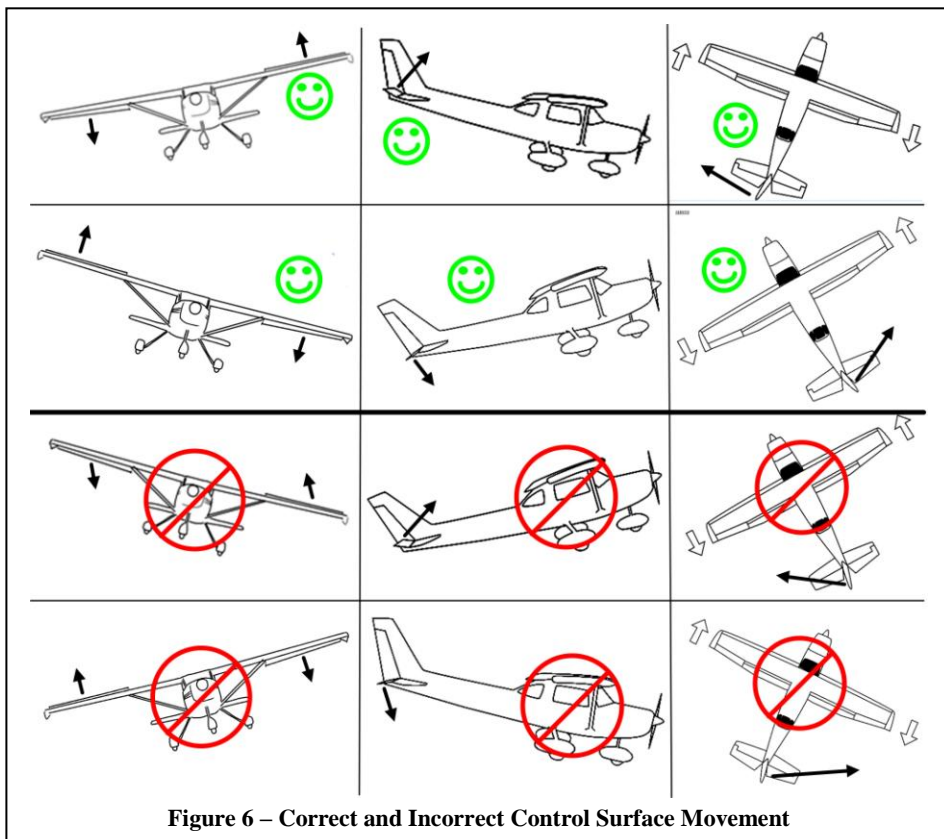

**Figure 6 – Correct and Incorrect Control Surface Movement**

ground with little or no input, then your configuration is correct. If the model oscillates or overcompensates during the hand-toss, your Gain is too high.

Once it has been shown that the Guardian has been correctly configured, perform a run-up on the ground with stabilization enabled, while watching your control surfaces for drift. If it appears as if stabilization is working properly with the engine active, then throttle down, perform one last preflight check and take off with power.

### **Don't fly your model if your control surfaces are moving unexpectedly during engine run-up!**

Once in the air and only when safe, release the control stick so it sits at zero deflection with 2D Mode enabled. Your airplane should fly straight and level. If not, your Guardian may be mounted improperly or you need to re-trim your airframe. Disable stabilization by flipping the Mode/Config switch to the center position (if available). Trim your controller in this mode until the plane achieves level flight. Land and follow the instructions for "Resetting Trims" on the ground.

## Tuning Stabilization Gains

### Stabilization Theory

The Guardian 2D/3D Stabilizer uses accelerometers and gyroscopes to measure the orientation of your model relative to the local direction of Earth's gravity. In addition, it interprets Pitch and Roll attitudes commanded by your Elevator and Aileron stick movements, respectively.

With this information, it is able to determine the error between your requested flight attitude and your plane's true orientation. By passing this error through a controller algorithm and sending it as servo commands through its Elevator, Aileron and Rudder outputs, the Guardian can help turn your squirrely model into a smooth-flying wing on rails!

Each axis has a separate gain control dial, which is used to adjust gain on that axis. The Pitch, Roll and Yaw gains are then scaled by the optional Overall "Master Gain" control, which can be mapped to a knob (or slider) on your transmitter. This arrangement allows individual axis gain adjustment while also providing in-flight Overall Gain adjustment to compensate for varying conditions and aerodynamic performance.

In general, the higher the gain, the more responsive and resilient your plane will be to disturbances such as wind, balance and trim issues. Tuning the gains too high however may result in oscillations of the airframe. It is recommended that the Master Gain control be used to tune the airframe until it barely oscillates and then be turned back down. This will ensure the best performance while preventing future oscillations.

 Since the Guardian interprets your radio's control stick inputs as commanded Pitch/Roll angles or angular rates, it is common for the servos' movements to be exaggerated when you move the control stick at high gains. This is normal. In the air, the plane should perform as expected. See *Preventing Damage to Your Model* for information on limiting servo throws with the Guardian.

### Components of Stabilization

The Guardian employs two major techniques to stabilize your model: "rate stabilization" and "orientation stabilization". Sometimes called "derivative" and "proportional" stabilization respectively, these two behaviors work together to smooth out bumps in the air while keeping your model in the orientation you want it.

#### Rate Stabilization

This is the reaction of the model to instantaneous motion. Specifically, it is the movement of your servos to oppose the *angular rate* of your model. The faster your model is rotating in a given direction, the harder the Guardian will oppose that motion. This is the effect that smoothes turbulence and makes your model feel more stable. In addition, when you fly in 3D Mode with 3D Heading Hold disabled, this is the only type of stabilization used.

#### Orientation Stabilization

This is the reaction of the model to the error between its current orientation and its commanded orientation. For instance, in 2D Mode with the sticks centered, the further the model is brought from level orientation, the harder the Guardian will fight to bring it back. This behavior is also used in 3D Mode when 3D Heading Hold is active to keep the model pointed in its locked direction.

 When in 3D Mode, Orientation Stabilization is used in the Pitch, Roll and Yaw axes to keep your model on track. When in 2D Mode, Orientation Stabilization is only used on the Pitch and Roll axes, leaving the Yaw axis (Rudder) only with Rate Stabilization. This will make the Rudder appear to be stabilizing less than the Elevator and Ailerons (or Elevons) in 2D Mode. This is expected behavior.

### Individual Axis Gain Dials

The gain control dials on the Guardian can be used for tuning the individual axes on your airframe. In addition, they allow for the reversal of the direction of stabilization servo travel. When a dial is centered (with the "double-dot" dial indication facing upwards, as shown in Figure 7) the gain for that axis is set to zero. This effectively disables stabilization on that axis.

When a dial is rotated away from its centered position in the clockwise direction, the gain for that axis is increased, and the stabilization deflection direction is set to normal. If the dial is rotated counterclockwise from its centered position, the gain will be increased as well, but the stabilization deflection direction will be reversed. This allows for stabilization to be tuned for any airframe, regardless of servo orientations.

 If you have difficulty seeing the double-dot indication on the dials, you can either gently rotate the dials counterclockwise and clockwise to find the approximate center point, or you can use the PC software to visualize the dial settings on your computer screen.

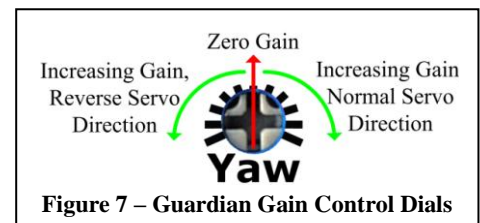

### Stabilization "Master Gain" Control

The Master Gain control increases or decreases the effective amplitude of the Pitch/Roll/Yaw gain dials and serves as a way to easily tune all three. If you have an RC controller that has a free analog knob or slider, this can be mapped to the Gain channel to allow for overall in-flight stabilization gain adjustment. The higher the gain knob setting, the stronger the Guardian's stabilization effect will be.

Another way to think about this is that it is similar to a graphic equalizer and volume control on a stereo. The individual gains are similar to the sliders on the equalizer, while the Master Gain is similar to the overall volume control.

Though not required, ideally the Gain wire from the Guardian will be plugged into a channel controlled by a knob, slider or switch on the transmitter. If you do not have a knob or slider on your transmitter than can be used for the Master Gain function, you may use a two or three position switch to provide low/high or low/mid/high gains by adjusting the travel limits in your transmitter. If you have no available channel for the Gain wire, you may leave it disconnected. In this case, the gain range of the individual gain dials is reduced to slightly less than half of the maximum possible gain to reduce the possibility of encountering oscillation. See the figure 7A below.

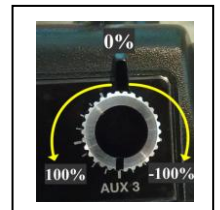

Setting the Pitch/Roll/Yaw gain dials on the Guardian and the Master Gain control on the transmitter at maximum provides maximum stabilization.

**⚠ Too high of a gain setting can result in oscillation: see the Oscillations section for more information on this.** Setting Master Gain control to the minimum will lower the overall gain to zero, while positions in between will yield proportional gain. Lowering the individual gain dials on the Guardian will lower the gain for that axis only and allow fine tuning. This might be desirable if, for instance, oscillation is encountered on one axis but not the others.

One possible strategy for setting gains would be to set all three of the individual gain control dials to maximum and the master to zero. While flying the plane with the Guardian engaged, slowly turn up the Master Gain and watch for signs of oscillation. If oscillation is encountered, back down the Master Gain until it ceases. With the plane on the ground, reduce the setting on the potentiometer for the axis for which oscillation was observed. Repeat until the plane can be flown with the Master Gain in its middle position without oscillation. If you have a plane with a wide speed range, such as a hovering 3D aircraft, using this procedure using only the mid range on the Master Gain will allow you later to turn it even higher when hovering or performing other slow speed aerobatic maneuvers as oscillation is seldom a problem under these conditions.

**👉** If continuous oscillations are experienced with the Master Gain wire disconnected, switch the Guardian off immediately with the Mode switch if necessary, and land. On the ground, reduce the gain dial for the oscillating axis as described above.

**👉** If connecting the Gain channel on a model where the Guardian had been previously tuned without it, ensure that the position of the Master Gain knob, slider or switch is set at slightly less than the centered position (see figure 7A) to prevent the possibility of strong oscillations on takeoff.

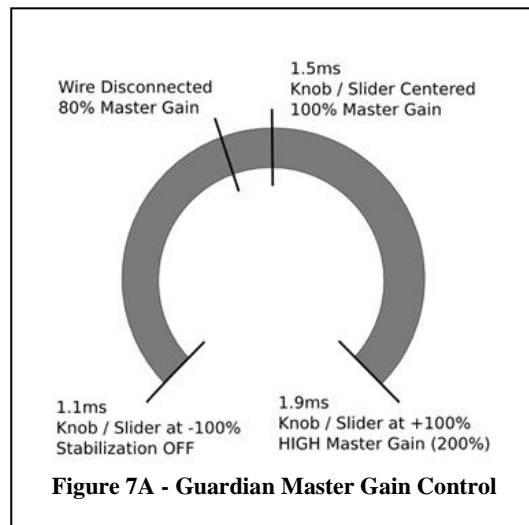

**Figure 7A - Guardian Master Gain Control**

## Oscillations

Sometimes, when the controller gains are set very high or if your model flies at a very high airspeed, oscillations can develop. If oscillations occur, turn down the Master Gain control or the gain dial for the axis that is oscillating (i.e., the Pitch axis), until the oscillations stop. Other causes of oscillations include mechanical slop in control surfaces and slow servos. If your model has digital servos, higher gain values may be made possible by increasing the Output Servo Pulse Frequency. See: *List of Menu Features and Options: Output Servo Pulse Frequency*.

## Oscillation Suppression

To help reduce pilot workload, the Guardian will automatically scale down the Overall Gain when it detects oscillations. To do this, it incrementally scales the Overall Gain down to a minimum of 50% of its currently set value. After the oscillations are eliminated, it will slowly increase the Overall Gain back up to 100% of its set value or until oscillations are detected again, whichever comes first.

If oscillations occur and subsequently disappear, it is recommended that you slowly reduce your gains to prevent this from happening in the future.

Do not increase the Overall Gain after an oscillation has been suppressed, since doing so will only cause more oscillations until the Oscillation Suppression is unable to reduce the Overall Gain sufficiently to be effective.

## Preventing Damage to Your Model

### In-Air Recovery

**⚠ The Guardian is a great tool for beginners looking for a safety net in case of lost orientation or control, however switching to 2D Mode with a combination of too-high airspeed and gains may cause damage to the airframe.**

If the model is not structurally capable of pulling out of a steep dive very quickly, some configuration may be needed to prevent excessive G-Forces. Reduce the Overall Gain (if connected) during high speed maneuvers or limit the travel of the servos through the PC software's Expanded / Custom Servo Ranges configuration tool under the "Servo Config" tab. Test your changes carefully and conservatively.

### Servo Binding / Stripping

**⚠ The Guardian may deflect any connected servos beyond the ranges defined in your controller's servo deflection settings. Exercise caution when first configuring your model to prevent binding or stripping.**

If moving the model or deflecting your control sticks results in any Guardian-controlled servos binding or reaching their mechanical extents, you can limit their movement in the Guardian PC software by selecting the "Servo Config" tab, setting "Output Servo Ranges Custom" to "On" and assigning specific endpoints for each servo channel. For more information, please see "The Servo Config Tab" under the "Guardian Configuration Page Software Reference" section.

## Tuning for Optimal Gains

While not needed for a good stabilization experience, there is a maximum gain configuration that can be found that will provide the best flight performance with the Guardian. This entails setting the highest gains for each axis without triggering oscillations. To do this, start out with the individual gain control dials set for their maximum correct deflections as described in the "Overview/Quickstart" section. Take off with the Master Gain control knob turned down low and once at a safe altitude and cruise speed, turn it up slowly to enable stabilization. Continue turning it up until an oscillation occurs. Note which axis upon which it occurs, reduce the overall gain, and land. Reduce the individual dial gain of the axis that was showing oscillations. Repeat this process until all three axes oscillate at the same Overall Gain level or no oscillations can be triggered.

## Status LED

The Guardian's LED uses blink sequences to convey information about system status, the current flight mode and any errors that have been detected.

### LED Indication during Startup

The LED will turn ON for 2 seconds, and then slowly blink the number representing the *Model Control Type* currently selected (1 blink = Standard, 2 = Elevation, 3 = V-Tail). See *List of Menu Features and Options: Model Control Type* for more information. After this startup blink sequence, the LED will display Steady State status as described below.

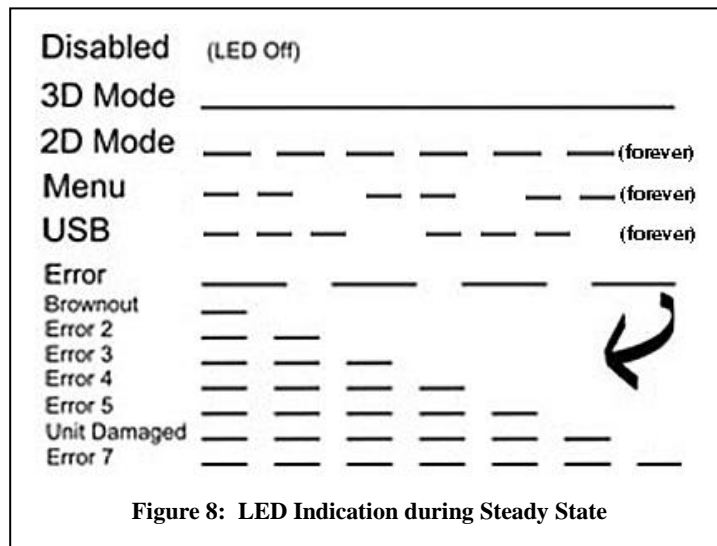

**Figure 8: LED Indication during Steady State**



### LED Indication during Steady State

- Solid On: 3D Mode
- One repeated blink: 2D Mode
- Solid Off: Stabilization Disabled

### Additional LED Messages

- 2 repeated blinks: Radio Stick Menu is active
- 3 repeated blinks: USB is connected
- 4 repeated blinks: Error condition. Error type is indicated by a pause and a number of additional, faster blinks:
  - One blink: Brownout – BEC or receiver battery is providing insufficient power for your servos and the Guardian. See the *BEC/Receiver Battery Power Requirements* section above.
  - 2 – 5 blinks: Memory / Calibration Errors – Repower the Guardian to clear. If this problem occurs repeatedly, contact technical support.
  - 6 blinks: Sensor Fault – If this problem occurs repeatedly, mechanical stress or damage to the board may have occurred.
  - 7 blinks: Internal error. If this problem occurs repeatedly, contact technical support.

## Mode/Config Switch Behavior

The Mode/Config input on the Guardian lets you change your stabilization mode in-flight between 2D Mode, 3D Mode and Disabled (if a 3 position switch is used). Additionally, you can configure the Guardian in the field via a series of toggles of the Mode/Config switch (within 15 seconds of Guardian power up), referred to as “Configuration Gestures”.

Leaving the Mode/Config input disconnected will cause the Guardian to switch to the Default Flight Mode. The factory default of this setting is “2D Mode.” If you want to use a different mode in this case, you will need to use the PC software to set the mode, or temporarily connect the Mode/Config input to change the mode via the radio stick configuration. See the Default Flight Mode menu item in the *List of Features and Options* section below.

### Flight Mode Selection

Please refer to Figure 9. The Guardian has three main operating modes (described earlier) that can be set by the Mode/Config switch position:

- Down: ( Position 2 , -100%, 1.1ms): 2D Stabilization Mode:
- Middle: (Position 1, 0%, 1.5ms, only available if you are using a 3 position switch): None – No stabilization or damping. All servo signals are directly passed through. (Elevon and V-Tail mixing is still performed)
- Up: ( Position 0, +100%, 1.9ms): 3D Stabilization Mode

☞ The meaning of each switch position can be custom defined through the PC Software. See *The Mode Config Tab* in the *The Guardian Configuration Page Software Reference* section of the manual, for more information.

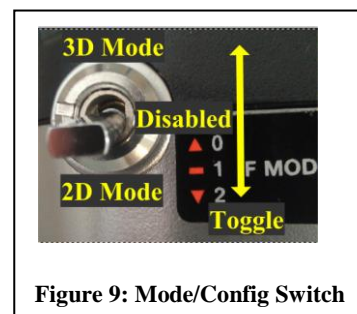

Figure 9: Mode/Config Switch

### Configuration Gestures

Within 15 seconds after Guardian power-on, the Guardian can be configured by toggling the Mode/Config switch back and forth rapidly. The number of times you toggle the switch determines which configuration step is performed. Note that if you have a 3 position switch, its center position is not used during toggling.

☞ The switch you are using on your radio must be configured with its endpoints at approximately -100%, 100% for Configuration Gestures to work correctly.

Here is a table of available configuration gestures, and what each does:

**Reset Level Flight and Trims:** 1 Toggle (up-down if the switch is presently down, or down-up if presently up)

After changing the trims on your controller or mounting orientation, you must let the Guardian know about this change so it can best control your airplane. Without this information, 3D Heading Lock will not work and stabilization performance will be degraded.

To update the trim and level flight information for your controller in the Guardian, quickly toggle the Mode Switch back and forth **once** within the first 15 seconds after power-on. You will know that the level flight orientation and trims have been reset when the servos both twitch **once** and then immediately return to normal movement.

If no twitch occurs when executing Reset Level Flight and Trims, it can either be because the switch gesture was not done quickly enough or within the first 15 seconds following boot. Alternatively, if the Guardian is mounted too far off of level flight (greater than 25 degrees in either Pitch or Roll), the Reset Level Flight and Trims will fail, presenting no servo twitch.

**Reset Trims Only:** 2 Toggles (up-down-up-down if the switch is presently down, or down-up-down-up if presently up)

Use this gesture to reset your trims without needing to also reset your level flight orientation.

To quickly update the trims of your plane in the Guardian, quickly toggle the Mode Switch back and forth **two times** within the first 15 seconds following power-on. (Example: up-down- up-down) You will know that the trims have been reset when the servos both slowly twitch **twice** and then immediately return to normal movement.

**Toggle Elevon Mixing:** 3 Toggles (up-down-up-down-up-down if the switch is presently down, or down-up-down-up-down-up if presently up)

A shortcut method for switching between normal and elevon mixed airframes.

To quickly switch elevon mixing on and off without needing to go into the Radio Stick Menu or use the PC software, quickly toggle the Mode Switch back and forth **three times** within the first 15 seconds after power-on. You will know that the mode has been changed when the servos both slowly twitch **three times** and then immediately return to normal movement. After this, moving your control sticks will reflect the current mixing configuration.

This action will toggle from Normal or V-Tail Mode to Elevon Mode and from Elevon Mode to Normal Mode.

**Enter Radio Stick Menu:** 4 Toggles (up-down-up-down-up-down-up-down if the switch is presently down, or down-up-down-up-down-up-down-up if presently up).

Enters menu mode (described below).

### Radio Stick Menu Operation

The Guardian 2D/3D Stabilizer has many advanced features that can be configured through the Radio Stick Menu.

#### Entering the Radio Stick Menu

Entering the Radio Stick Menu is done by powering the model with the Guardian connected and quickly toggling the Mode/Config Switch back and forth **four times** within the first 15 seconds following power-on. One second after the last switch movement, the menu will be invoked.

You will know that the menu has been invoked when the servos of your model stop their normal stabilization deflections and instead perform a short twitch followed by no further movement. Also, the status LED will blink in a two blink sequence when the menu is active.

### Menu Navigation

Once in the menu, you will start at menu item #1 in the *List of Features and Options* section below. The menu items can be navigated by deflecting the Aileron and Elevator control inputs (your control stick). On a controller where moving the stick to the right and pulling it back results in negative servo deflections (servo pulse width is shortened), flicking the Aileron input to the right will increase the menu item number currently being edited, while flicking the Elevator input forward increases the option value for the currently selected item in the menu.

Menu feedback is reported through the Aileron and Elevator servo outputs, as shown in Figure 10. Each time a new menu item is selected by flicking the Aileron control, the Aileron servo will “twitch” once, delay 1.5 seconds and then twitch rapidly a number of times that corresponds to the current menu item number selected. After this, the Elevator servo will count up to the current option value number selected for that menu item. If a new option value is chosen by flicking the Elevator stick, the Elevator servo output only will twitch once each time the value is changed, wait 1.5 seconds and then count up to the selected option value number.

-  **If you have your Aileron or Elevator directions reversed on your transmitter, then they will also be reversed as you navigate the menu!**
-  **If you have reduced the rates/deflection ranges configured on your transmitter for your servos, ensure that they are deflecting at least 50% in order for the menu to detect their movements.**

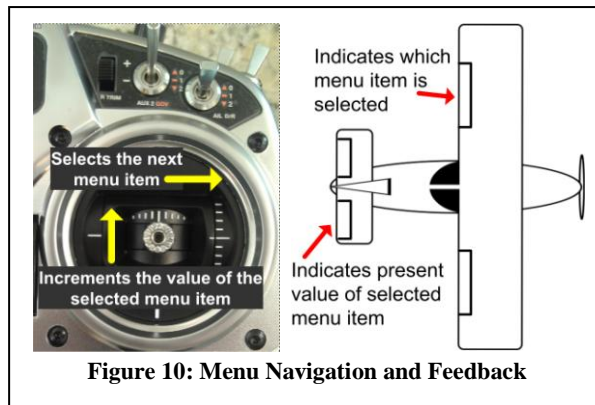

**Figure 10: Menu Navigation and Feedback**

### Exiting the Menu

To exit the menu, saving the settings that were changed, quickly toggle the Mode/Config switch back and forth once. (up-down or down-up) Once out of the menu, normal servo deflections will start again, using the new settings.

To exit the menu without saving your changes, simply disconnect the receiver battery and repower the plane. The Guardian will boot up again with its previous settings.

### Menu Example

Let's say you want to set the 2D Heading Hold Gain (menu option 5) to a value of 6. First, toggle the Mode/Config switch 4 times, to enter menu mode, which starts at menu option 1. Then, you will flick the Aileron stick to the right (or left, if your ailerons are reversed) 4 times, to reach menu option 5. Then, your Aileron should twitch 5 times, to indicate that menu option 5 is selected. And, your Elevator will twitch a number of times, indicating the present setting for the 2D Heading Hold Gain. Then, flick your Elevator stick up or down, to increase or decrease the 2D Heading Hold Gain setting, until it reaches 6. At this point, the Elevator should twitch 6 times, which is the desired setting. To save the new setting, toggle the Mode/Config switch once, which exits menu mode, and returns servo control.

## List of Menu Features and Options

The following is an ordered list of all the options adjustable in the Guardian's Radio Stick Menu, and from the PC software. Note that options 14 and higher are available only via the PC software.

### 1. Model Control Type

Enables internal mixing if needed. The Guardian expects only an unmixed servo control signal from the Rx.

- 1: Standard – Dual ailerons / flaperons are supported.
- 2: Elevon – The Guardian does the elevon mixing internally. Dual Aileron / Flaperon support is not available.
- 3: V-Tail – The Rudder and Elevator channels are mixed internally. Dual ailerons / flaperons are supported.

### 2. Center Stick Stabilize Only Mode

This feature is primarily for those who don't have the Mode/Config switch connected, but want the benefits of 2D mode while also being able to perform acrobatics. Maximum 2D Mode stabilization is active when the control stick is centered, and as the control stick is moved from center, the Overall Stabilization Gain reduces proportionally as illustrated in Figure 11. (2D Mode Only)

Radio Stick Menu Options: 1: Off; 2: On

### 3. Center Stick Box Size

The maximum deflection of the control stick before stabilization is fully disabled in Center Stick Only mode. The stabilization gain will decrease proportionally with the deflection of the control stick from its centered position. Once the stick is moved past a certain point, controlled by this setting, stabilization is fully disabled. (2D Mode Only)

Radio Stick Menu Options: 1-10: Center Stick Box Width

### 4. Automatic Turn Coordination

Employs the “Step On The Ball” method to move the Rudder in order to coordinate your turns in 2D Mode. For more information, see “Automatic Turn Coordination” under the “Main Features”/“2D Mode” section. (2D Mode Only)

 **When taxiing in 2D Mode on an incline, this feature will try to yaw your model down the hill. Additionally, if the Guardian is not very close to the center of gravity, then this feature can increase the chance of Yaw oscillations.**

Radio Stick Menu Options: 1: Off; 2: Low; 10: High

### 5. 2D Heading Hold Gain

When the control stick is centered horizontally (zero Roll command) in 2D Mode, the controller will roll the plane to track its current heading. (2D Mode Only)

Radio Stick Menu Options: 1: Off; 2: Low; 10: High

### 6. Direct Rate 3D Control

When in 3D Mode, the plane will react much more precisely with this feature enabled. Instead of simply stabilizing the 3D flight, it will control the rotational rates of the plane directly. This provides very strong disturbance (wind, airframe inertia, etc) rejection without having to “fight the gyro”. (3D Mode Only)

 **This feature will expand your servo deflections beyond any limits set on your transmitter, up to the limits set by the Guardian. See Expanded / Custom Servo Ranges for more details on how to limit servo deflections.**

Radio Stick Menu Options: 1: Off; 2: On

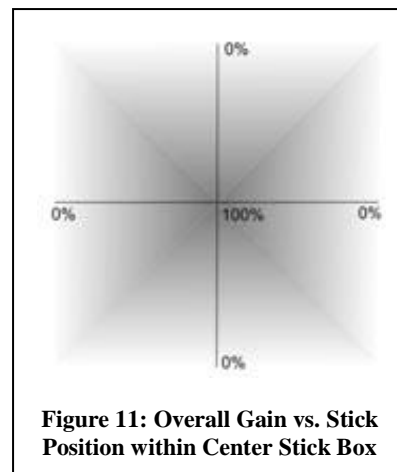

**Figure 11: Overall Gain vs. Stick Position within Center Stick Box**

## 7. Enable 3D Heading Hold

Enables the 3D Heading Hold feature in 3D Mode. Those looking for the stability and precision of the Guardian without anything else getting between them and their airplane can disable this feature for a rate-gyro experience. Be sure to move the your radio's control stick to reset the locked heading immediately before takeoff. (3D Mode Only)

 Enabling Direct Rate 3D Stabilization is strongly recommended if this mode is set to "Off".

Radio Stick Menu Options: 1: Off; 2: On

## 8. Derivative Gain

Tunes the dampening/derivative gain of the airplane. Increasing this value will strengthen the "rate gyro" behavior of the Guardian while leaving the 2D leveling and 3D Heading Hold behaviors the same.

 Increasing this value without reducing your overall or individual axis gains will increase the chance of oscillations.

Radio Stick Menu Options: 1: Low Derivative; 10: High Derivative

## 9. Onboard Dual Aileron Mixing Enabled

Configures the Guardian to accept unmixed Aileron and Flap (Aux In) inputs and mixes them internally to provide Dual Aileron / Flaperon outputs on Ail and Aux Out. If disabled, the Guardian will accept premixed Flaperon signals. Useful with limited controllers that cannot perform Flaperon mixing. Disabled by default.

Radio Stick Menu Options: 1: Off; 2: On

## 10. Aux Servo Output Reversed

Reverses the direction that stabilization will move your second Aileron servo if you are using the Aux channel in a Dual Aileron configuration.

Radio Stick Menu Options: 1: Off; 2: On

## 11. Reverse 2<sup>nd</sup> V-Tail /Elevon

Set this if the second V-Tail or Elevon servo on a "Delta" wing plane is not symmetrically mounted and is resulting in incorrect servo movements.

Radio Stick Menu Options: 1: Off; 2: On

## 12. Expanded / Custom Servo Ranges

Allows advanced users to expand the functional range of their servos from 100%(±400us) around their trim values to 150%(±600us) around their trim values. Overall servo deflection range is expanded to by default to 125%(1500us ± 500us) around the standard servo neutral position. When configured on the PC software, this option also enables custom servo limits that can be set there.

 This can damage your servos and your plane if activated carelessly. It is included for modelers that either need the extra range or wish to limit the ranges to their servos. Make sure to reset your trims before activating this mode!

Radio Stick Menu Options: 1: Off; 2: On

## 13. Default Flight Mode (For when Mode/Config switch is unused/disconnected)

If you don't have the Mode input channel connected during flight, the Guardian will use the flight mode selected here. Note that you will need to set this with the PC Software, or temporarily connect a switch to the Mode input channel to set it.

Radio Stick Menu Options: 1: 2D Mode (default); 2: 3D Mode

## 14. Output Servo Pulse Frequency (PC Software Configuration ONLY)

Sets the pulse frequency of the servo signals going out of the Guardian. A default of 50 Hz is recommended for analog servos, but some digital servo support higher frequencies. If the electronics are designed for it, the maximum frequency of 400 Hz will improve stability on more responsive airframes.

 Setting this option above 50Hz for analog servos can cause them to work too hard and may cause damage if left for too long. Use with caution.

## The Guardian PC Software

Firmware update, quick and easy configuration of the Guardian, and the ability to save and restore configuration profiles are supported via our powerful Guardian configuration software. Some advanced features beyond fixed-wing operation are also only configurable in the software.

The Guardian connects to your Windows PC or laptop through its integrated USB Micro B connector. A standard "Micro B" USB cable is required to use the software, but is not included. Generally, USB cables for recently made mobile phones and eBooks (that let you access these devices on your PC) should work, so you probably already have a suitable USB cable. If not, you can purchase it at most major stores, or from Eagle Tree (p/n USB-CAB-MICRO). Note that there are "charge only" USB cables that will not let you access your device on the PC, and will not work with the Guardian.

When connected, the USB cable will only power the Guardian, not the servos or receiver. Powering the servos and receiver while the Guardian is connected to USB is fine, just use caution when changing settings as it is possible to strip out servos accidentally through some settings.

### Installing the Software

The Guardian software is installed from the support page of our website, located at <http://eagletreesystems.com/Support/apps.htm>. Please install software version 10.63 or later from our website.

### Running the Software and Updating the Firmware

After installation, just click on the Data Recorder icon on your desktop, or select the Data Recorder application under the Windows start menu. A message should appear that requests you to connect the Guardian to USB, if it is not already connected. After USB connection, you may be prompted to update the Guardian firmware. If so, click the "Update" button for the Guardian 2D/3D Stabilizer on the Firmware Control page, and follow the on-screen prompts. Once the firmware is updated to the latest version, the Guardian Stabilizer Configuration Dialog should appear.

### Running the Guardian Software if you have other Eagle Tree Products Configured on your PC

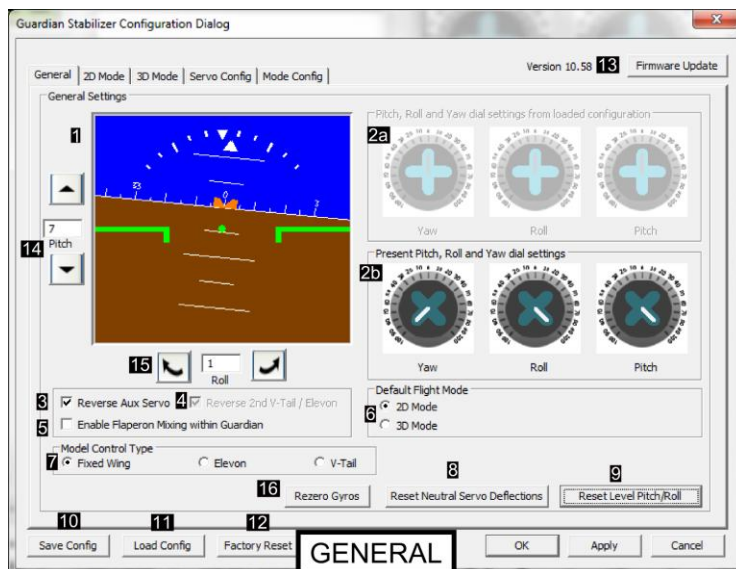

If you have other Eagle Tree products (such as the eLogger, OSD Pro, or Seagull) the main software screen will continue to appear, just as it does now. To launch the Guardian Stabilization configuration page, just click “Hardware, Configure Guardian 2D/3D Stabilizer”.

## Guardian Configuration Page Software Reference

### The General Tab

1. Artificial Horizon Indicator (AHI): Displays the measured Pitch/Roll of the Guardian relative to level (when in 2D mode) or when in 3D Mode, relative to the last locked 3D Heading. Note: since 3D mode results in the AHI showing level related to the last locked 3D heading, it will NOT display true level when your model is sitting level. Switch to 2D mode if you want the AHI to display true level.
2. Indicators for the positions of the dials on the Guardian (2b) and the last recorded positions as loaded from a saved file (2a). When loading a saved configuration file, you can use the two displays to match your previous dial configurations with your current setup, allowing you to easily replicate the saved profile.
3. See: *Aux Servo Output Reversed*
4. See: *Reverse 2<sup>nd</sup> V-Tail/Elevon*
5. See: *Onboard Dual Aileron Mixing Enabled*
6. See: *Default Flight Mode*
7. See: *Model Control Type*
8. Reset Neutral Servo Deflections: When pressed, this will record the current servo signals coming into the Guardian from your receiver. If no receiver is connected and powered at this time, then the zero servo deflection of 1.5ms pulse length will be used as the failsafe value for each disconnected channel except for Gain and Mode, which will failsafe to approximately 40% gain and the currently selected *Default Flight Mode*.
9. Reset Level Pitch/Roll: Will record the orientation of the Guardian relative to level to compensate for mounting offsets. This step will fail if either the Pitch or Roll is greater than 25 degrees.
10. Save Configuration: Records your current settings as set on the Guardian to a .txt file to load later. Useful for saving profiles for individual airplanes.
11. Load Configuration: Recovers the settings from a previously saved configuration file and writes them to the connected Guardian.
12. Factory Reset: Restores the connected Guardian unit to its factory default settings.
13. Firmware Update: Loads the Firmware Control dialog.
14. Level Pitch Trim: Adjust this value to fine tune the level flight orientation in the pitch axis.
15. Level Roll Trim: Adjust this value to fine tune the level flight orientation in the roll axis.
16. Rezero Gyros: Zeroes the gyroscopes inside the Guardian. Under some circumstances, this can help improve leveling accuracy after extended maneuvering in the air.

### The 2D Mode Tab

1. Controls the 2D Heading Hold gain. When set above zero, this option determines how hard the Guardian will assert a roll to keep the airframe on its locked 2D Heading. 0: Off; 1: Low; 10: High. See: *2D Heading Hold Gain*
2. Controls the Automatic Turn Coordination gain. In 2D Mode, this feature will automatically coordinate your turns for you. 0: Off; 1: Low; 10: High. See: *Automatic Turn Coordination*
3. Stabilization Pitch/Roll Angle: The maximum target Pitch/Roll angles that the Guardian will allow your model to assert. This will be approximate as stabilization gains can affect this behavior.
4. See: *Center Stick Stabilization Only Mode*
5. See: *Center Stick Box Size*

### The 3D Mode Tab

1. See: *Enable 3D Heading Hold*
2. See: *Direct Rate 3D Control*
3. When Direct Rate 3D Control is enabled, this sets the angular rate in rotations per second for each axis that the Guardian will attempt to get your airframe to assert at full control stick deflection.
4. See: *Derivative Gain*

### The Servo Config Tab

1. See: *Expanded / Custom Servo Ranges*
2. If *Expanded / Custom Servo Ranges* is enabled, these fields allow an advanced user to specify hard limits to the Guardian’s outputs. Useful for custom setups that will be damaged by servo deflection beyond certain angles. Normal servo deflection pulse length ranges (+/-100%) are 1100 us to 1900 us. +/- 150% servo deflection ranges are 900us to 2100us.
3. Controls the pulse frequency from the outputs of the Guardian. Useful for digital servos. See: *Output Servo Pulse Frequency*

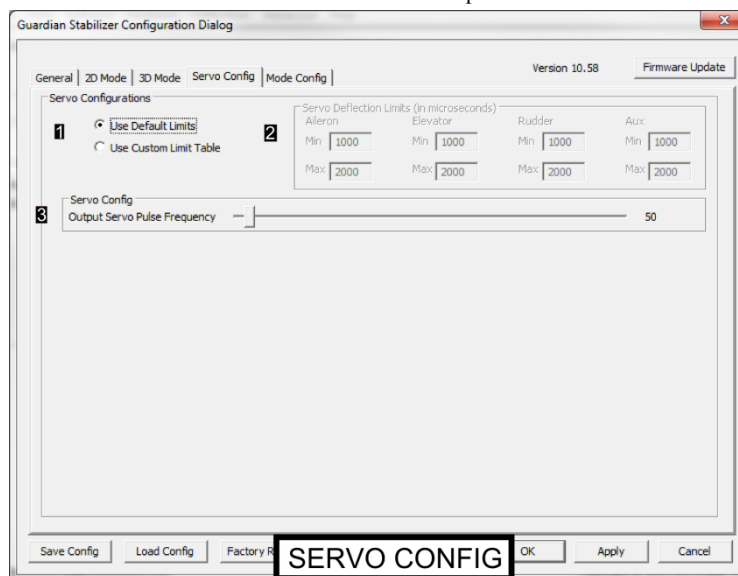
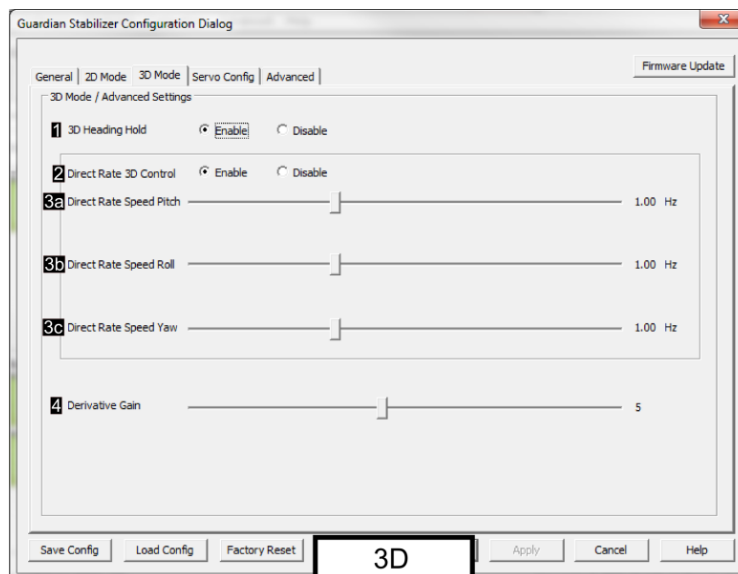
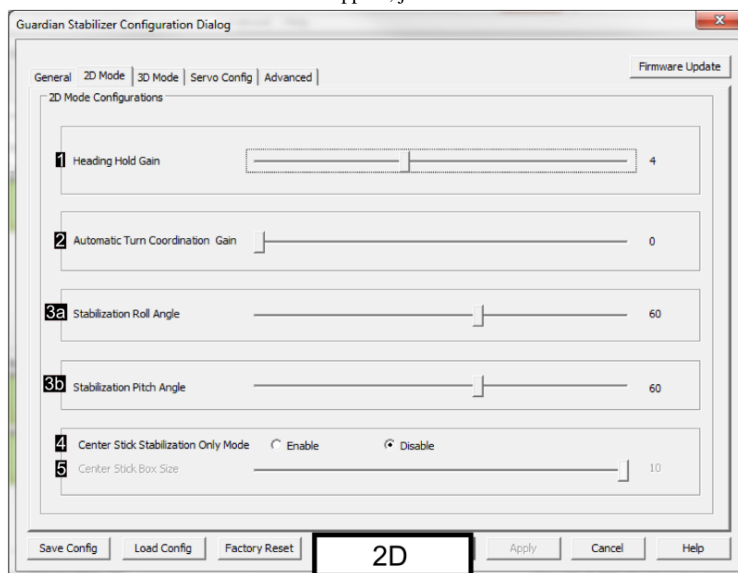

## The Mode Config Tab

1. Allows the configuration of the 3 positions on the Mode switch input to be customized. Use the drop down menus in each position field to customize which mode becomes active when that position is selected by the mode switch.

## Troubleshooting / F.A.Q.

**Question:** Is it OK to use dual/expanded rates/ranges on my transmitter?

**Answer:** While using expanded servo ranges on your controller will not cause problems, they are not needed and may cause confusion. The Guardian will use its own expanded ranges depending on your gains, and any Custom Servo Ranges that may be defined through the PC App. In both 2D and 3D Modes, higher gains will result in an improved responsiveness. In 3D Mode, activating Direct Rate 3D Control and increasing the Direct Rate Speed for a given axis will cause the model to rotate more quickly around that axis. In this way, when stabilization is enabled, the Guardian 2D / 3D Stabilizer makes user-defined Dual (Expanded) Servo Rates unnecessary. If you need expanded servo ranges when stabilization is disabled, it is recommended that you configure your transmitter to enable those expanded rates only when your mode switch is in the “stabilization disabled” position. Consult your transmitter manual for details on doing this and to see if your transmitter is capable.

Please note that when testing with the aircraft sitting still on the ground, and the Guardian in 2D or 3D mode, you will not see the normal dual rates/expo behavior that you have come to expect when testing. You must disable the Guardian to check your dual rates/expo. Once in the air, the dual rates/expo should work as you would expect.

Below are the responses to non-standard servo ranges when stabilization is enabled:

**Reduced Servo Rates / Ranges:** In 2D Mode, full stick deflection will yield less than the configured “Stabilization Pitch/Roll Angle(s)”, making it feel like you are “fighting” with the Guardian. 3D Mode will exhibit slower than the “Direct Rate Speed” at full stick deflection. At some low servo rates, the Radio Stick Menu may not work correctly.

**Expanded Servo Rates / Ranges:** 2D Mode may not be able to prevent inverted maneuvers, even at high gains. In 3D Mode, expanded servo rates will result in proportionally faster Pitch/Roll/Yaw rates.

**Question:** This is my first flight with the Guardian, or my maiden flight with a new plane equipped with the Guardian. What should I do?

**Answer:** If it is your first time learning how to use the Guardian, it is strongly recommended that you first test it on an inexpensive and robust model that you have flown before. After performing the Guardian’s preflight check (consult the relevant portion of the manual) to confirm that stabilization is working correctly, use your Mode or Gain channel to disable it. Perform a standard take-off without stabilization and fly up to a safe height. Activate the Guardian at this time by slowly increasing your Gain or switching into 2D Mode. If your model begins to flip over, immediately disable stabilization, recover, and land. One or more of your individual axis gain control dials are likely turned the wrong direction. If oscillations occur, then your gains are too high. Turn down either your Overall Gain knob or bring the individual Guardian gain control dial of the oscillating axis closer to its center position.

**Issue:** The Guardian does not move my servos when I move the model around.

**Solutions:**

- Make sure that the gain control knobs on the Guardian are not in the center (vertical) position, which disables stabilization
- If you are using a 3 position Mode/Config switch, make sure it is not set in the center (disabled) position.
- If you are using a Gain knob on your transmitter, make sure that it’s not turned to -100% servo deflection, which will disable stabilization.

**Issue:** The Guardian moves my servos in the wrong direction as I move the model around.

**Solution:** The gain control knobs on the Guardian set the direction of stabilized servo movement, as well as the gain level.

**Issue:** My rudder is not moving or is not moving as much as the other control surfaces.

**Solution:** Unless you are in 3D Mode with 3D Heading Hold enabled, the Rudder will not deflect very much to oppose your flight movements in the Yaw axis. This is expected behavior. See the section called “Components of Stabilization” for more info.

**Issue:** Stabilization suddenly stops working or stabilizes incorrectly during flight, but resumes correct operation later.

**Solutions:**

- The Guardian may be experiencing brownout. See *BEC/Receiver Battery Power Requirements* section above.
- Make sure that the Guardian is securely mounted, and not “flapping around” during aggressive maneuvers
- If, during engine run-up, you notice the servos shifting or moving around inappropriately, you may need to move the Guardian away from sources of RFI (such as a powerful BEC or motor). Or, you may need to mount the Guardian differently to reduce excessive vibration.

**Issue:** Reset Level Flight doesn’t seem to work.

**Solution:** Make sure the Guardian is mounted approximately level. Mounting offsets in excess of 25 degrees from flat or upside-down can reduce performance and will cause the Reset Level Flight to fail.

**Solution:** Make sure the endpoints of the switch you are using with the Mode input are configured to approximately -100%, 100%. This is required for the Reset Level Flight and other Mode switch Configuration Gestures to work correctly.

**Issue:** My servos are getting stripped or are burning out due to excessive deflection.

**Solutions:**

- Reduce the gains on the channels that are experiencing too much deflection. This reduces both load and deflection.
- Use the Custom Servo Ranges option in the PC software to specify limits to the servo deflections. When properly configured, this guarantees that the servos will not bind or deflect beyond their engineered limits.

**Issue:** In the PC software, the Artificial Horizon Indicator (AHI) display is not correctly showing level, even when my model is sitting level on the table.

**Solution:** **The AHI will not show true level if the Guardian is in 3D mode.** In this mode, the AHI shows level based on the last time 3D lock was invoked (stick centered). Please switch the Guardian to 2D mode if you want the AHI to show true level.

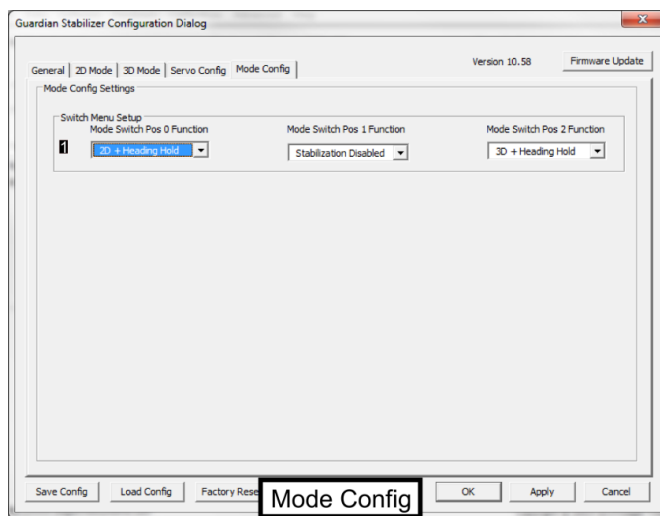

**Issue:** When I increase the Gain on the Guardian, I see one or more control surfaces move, even though my model is level.

**Solution:** This can happen if the Guardian does not know your latest trim settings. Make sure you perform the “Reset Level Flight and Trims” or “Reset Level Trims” operation (described above) each time you change your model’s trim settings.

**Issue:** My USB cable does not fit well in the Guardian’s USB connector.

**Solution:** We have received a few reports of tight-fitting USB cables. The Micro-B USB cable sold by Eagle Tree fits correctly, and we’ve also observed that Kindle™ USB cables and the mobile phone USB cables we have tested in-house fit well also. Note that “mini” USB cables will not fit!

**Issue:** I have performed a Reset Level Flight, but the AHI doesn’t seem to be accurate after moving the Guardian around and placing it flat again, or the model still isn’t flying level, particularly after turn maneuvers.

**Solution:** This can sometimes be solved by using the “Rezero Gyros” button on the General page of the Guardian PC UI and carefully following the directions in the PC software.

### **Regulatory**

The Guardian has been tested with a typical installation and was found to comply with EU EMC requirements. As with any change or addition to an R/C system, you are strongly advised to carry out a range and performance check before operating the equipment.

### **Limited Warranty**

Eagle Tree Systems, LLC, (ET) warrants to the original purchaser (the Purchaser) that the purchased product (the Product) will be free from defects in materials and workmanship for a period of one (1) year from the date of original purchase. This limited warranty is nontransferable.

This limited warranty does not cover problems that result from:

- External causes such as accident, abuse, misuse, or problems with electrical power
- Acts of God
- Commercial use
- Servicing not authorized by ET
- Product not purchased from an ET authorized dealer
- Usage that is not in accordance with the Product instructions
- Failure to follow the Product instructions

OTHER THAN THE EXPRESS WARRANTY DESCRIBED ABOVE, ET MAKES NO OTHER WARRANTY OR REPRESENTATION OF ANY KIND, AND HEREBY DISCLAIMS ANY AND ALL IMPLIED WARRANTIES, INCLUDING, WITHOUT LIMITATION, THE IMPLIED WARRANTIES OF NON-INFRINGEMENT, MERCHANTABILITY AND FITNESS FOR A PARTICULAR PURPOSE. THE PURCHASER ACKNOWLEDGES THAT HE OR SHE HAS DETERMINED THAT THE PRODUCT WILL SUITABLY MEET THE REQUIREMENTS OF THE PURCHASER’S INTENDED USE.

### **Remedy of Purchaser**

ET’s sole obligation and purchaser’s sole and exclusive remedy shall be that ET will replace or repair the Product, at our option. REPAIR OR REPLACEMENT AS PROVIDED UNDER THIS WARRANTY IS THE PURCHASER’S SOLE AND EXCLUSIVE REMEDY.

### **Limitation of Liability**

ET SHALL NOT BE LIABLE FOR SPECIAL, INDIRECT, INCIDENTAL OR CONSEQUENTIAL DAMAGES, LOSS OF PROFITS OR PRODUCTION OR COMMERCIAL LOSS IN ANY WAY, REGARDLESS OF WHETHER SUCH CLAIM IS BASED IN WARRANTY, CONTRACT, NEGLIGENCE, TORT, STRICT LIABILITY OR ANY OTHER THEORY OF LIABILITY, EVEN IF ET HAS BEEN ADVISED OF THE POSSIBILITY OF SUCH DAMAGES. Further, in no event shall the ET’s liability exceed the retail sales price of the Product on which liability is asserted.

As ET has no control over setup, use, assembly, modification or misuse of the Product, no liability shall be assumed nor accepted for any resulting damage or injury. By the act of setup, use, or assembly, the user accepts all resulting liability. If the purchaser or user is not prepared to accept the liability associated with the use of the Product, the purchaser is advised to return the Product immediately in new condition to the place of purchase.

### **Obtaining Warranty Service**

If the Product requires warranty service during this period, please email us at [support@eagletreesystems.com](mailto:support@eagletreesystems.com) or open a support ticket with us at <http://ticket.eagletreesystems.com> for further instructions.

*All technical information in this manual is subject to change without notice. All non Eagle Tree brand and product names referenced in this manual are trademarks of their respective holders.*