

Electrochemical Test Cell ECC-Opto-Std

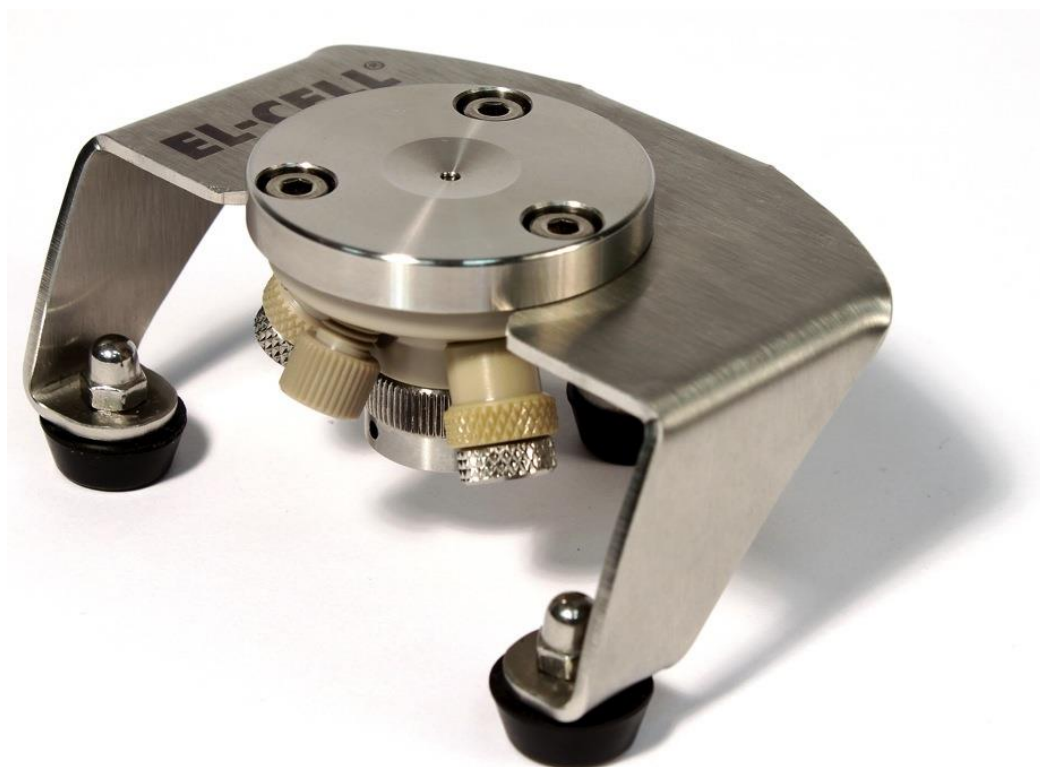

User Manual

Release: 2.2

2014-01-22

The information in this manual has been carefully checked and believed to be accurate; however, no responsibility is assumed for inaccuracies.

EL-CELL GmbH maintains the right to make changes without further notice to products described in this manual to improve reliability, function, or design. EL-CELL GmbH does not assume any liability arising from the use or application of this product.

Contents

- 1 Product Description 3
- 2 Features 3
- 3 Safety Precautions..... 5
- 4 Unpacking..... 5
- 5 Assembly and Connection 6
- 6 X-ray Experiments 8
- 7 Disassembly and Cleaning..... 9
- 8 Accessories and Spare Parts..... 10
- 9 Technical Support..... 12
- 10 Warranty 13

EL-CELL GmbH
Tempowerkring 8
D-21079 Hamburg - Germany
phone:+49 (0)40 790 12 733
fax: +49 (0)40 790 12 736
info@el-cell.com
www.el-cell.com

1 Product Description

The ECC-Opto-Std test cell serves to monitor the optical properties of an electrode material in the course of electrochemical charging. For this purpose, the working electrode (WE) material is placed right below an optical window, and is contacted by a holed current collector foil. This WE is sandwiched from below with a glass fiber separator and an appropriate counter electrode. Thus, the optical instrument “looks” from the top through a glass window onto the backside of the WE material. Typical instrumentations include optical microscopy and confocal Raman spectroscopy in the reflection mode. A re-fitting kit for X-ray is available as an option. The maximum diameter of the working electrode is 10 mm while that of the inspection hole is 1 mm (optional up to 10 mm). The cell is equipped with a reference electrode for 3-electrode operation.

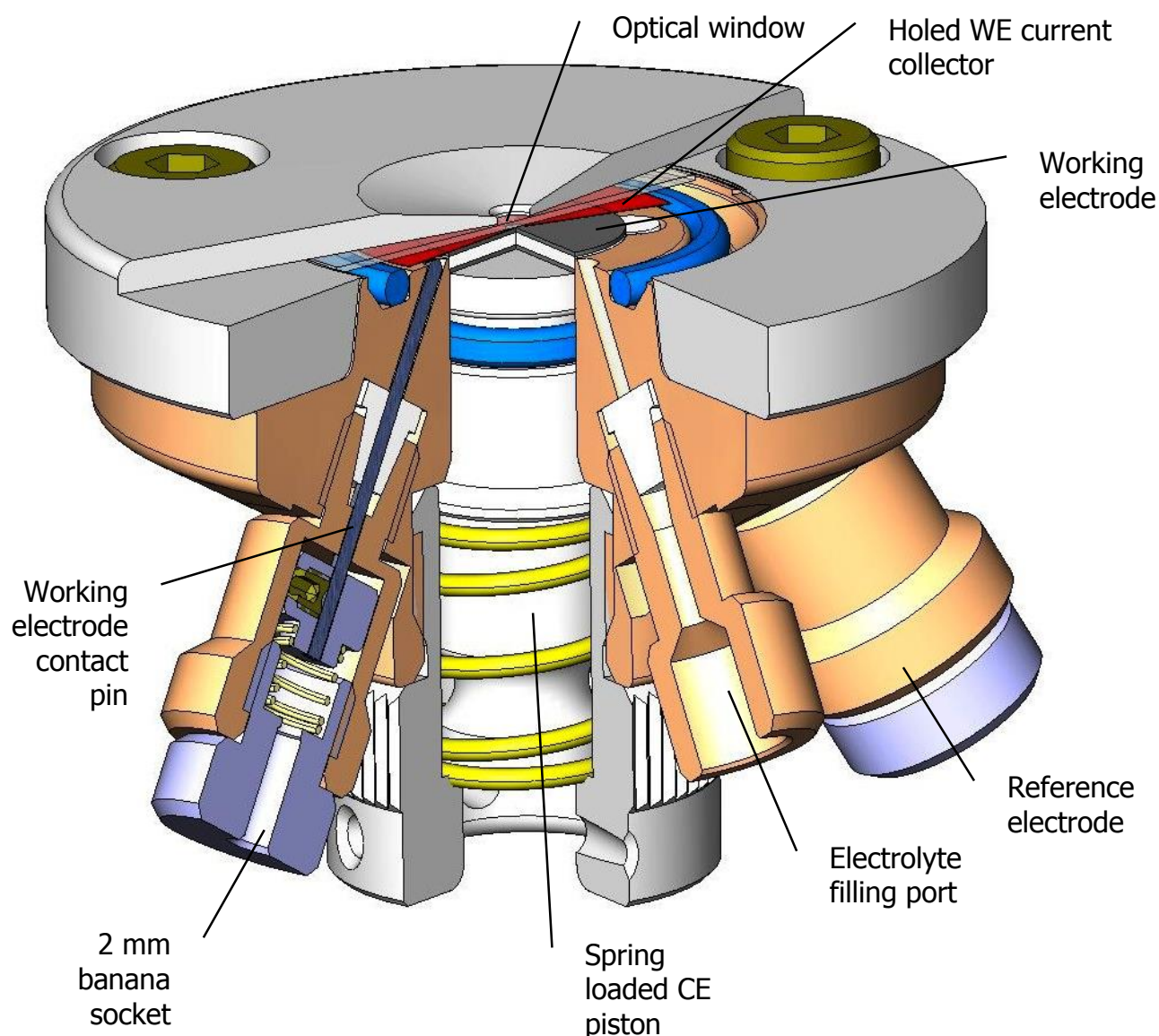

2 Features

- 3-electrode cell with optical window for aprotic electrochemistry. A version for aqueous electrochemistry is available on request.
- Materials in media contact are stainless steel 1.4404, PEEK and EPDM
- The backside of the working electrode material can be observed through a holed current collector and the optical window on top. Inspection area diameter is 1 mm. Other diameters up to 10 mm available.
- Typically used in combination with optical microscopy or Raman spectroscopy in the reflection mode. X-ray option with Beryllium window available.
- The window is made of optical glass. Sapphire, Beryllium and Kapton windows are available on request.
- Working electrodes can be single crystals or grains, powder samples, and bound electrodes (self-supporting or with an expanded metal / holed metal foil as the current collector). Maximum electrode diameter is 10 mm.
- Easy and clean electrolyte filling via the vacuum (syringe) method. All necessary equipment is included.
- Cell assembly and filling are to be carried out inside a glove box. Once sealed, the cell may be operated outside the box at ambient atmosphere.
- Fast assembly and dismantling, and easy cleaning of cell components
- Electrodes are conveniently accessible for post-mortem analysis
- Re-usable cell components
- Small and defined electrolyte volume down to 0.3 cm³ due to minimized dead volume
- Adjustable, reproducible and homogeneous mechanical pressure on the electrode stack.
- Connection to potentiostat/ battery tester via 2 mm banana sockets
- Temperature operation range -20 to +70 °C
- Size (including stand): 46 mm x 88 mm x 63mm (height x width x depth)
- Weight: approx. 210 g

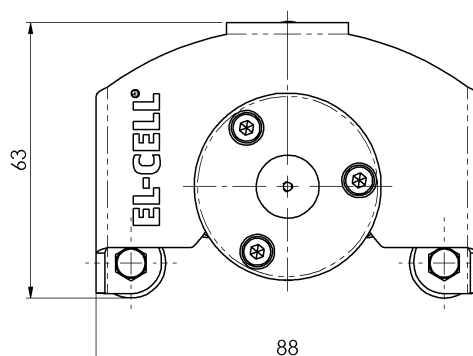
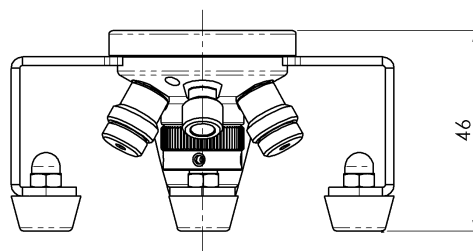

3 Safety Precautions

Use proper safety precautions when using hazardous electrode materials and electrolytes. Wear protective glasses and gloves to protect you against electrolyte that may accidentally spill out during filling and disassembly. Upon cell disassembly, dispose all materials properly. Metallic lithium and some insertion compounds may decompose heavily in contact with water and other solvents, and can cause fire.

4 Unpacking

Check the contents of the packages against the list given below to verify that you have received all of the components. Contact the factory if anything is missing or damaged. **NOTE:** Damaged shipments must remain with the original packaging for freight company inspection.

List of Components

1. ECC-Opto-Std test cell with stand, fully equipped for use in both 2-electrode and 3-electrode (reference) configuration in aprotic electrolytes
2. Transfer line with syringe (5 ml) for vacuum filling
3. Glass windows (5 pieces)
4. Glass fiber separators (5 pieces)
5. Holed current collector foils Aluminium (5 pieces)
6. Holed current collector foils Cooper (5 pieces)
7. Sealings (2 x 2 O-rings)

5 Assembly and Connection

Generally, all assembly steps are to be carried out in inert glove box atmosphere. All components used are to be dried upfront in a vacuum oven at 80°C for at least 12 hours. Once fully assembled, the cell is hermetically sealed so that it may be operated in ambient atmosphere.

The test cell can be used in either 2-electrode or 3-electrode (reference) configuration. In the following, the cell assembly is described for operation with a lithium metal reference electrode.

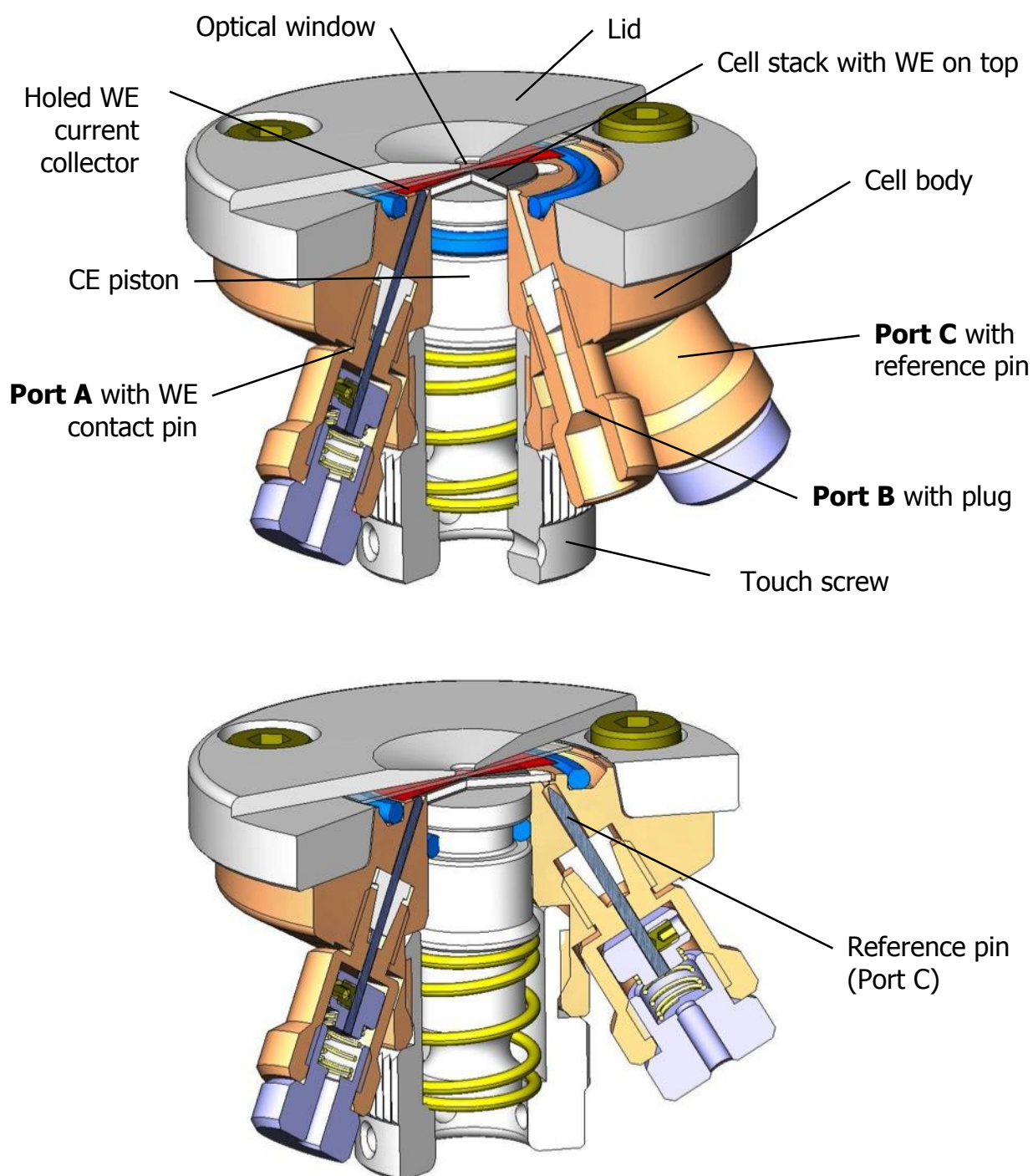

Assembly:

- i) By means of the optionally available [ECC-RefLoad](#), press a small piece of lithium metal into port C so that the Li metal just appears at the upper narrow end of the feed-through hole. Attach the spring-loaded reference pin to the port. Skip this initial step if working without reference electrode.
- ii) Push the counter electrode piston into the cell body to the uppermost position.
- iii) Pull the piston slightly back, and insert the Li counter electrode (max. 10 mm in diameter, max. 1 mm thick)
- iv) Put the provided glass fiber separator on top.
- v) Place the WE material onto the center of the separator. The WE material can either be a self-supported electrode film, a single grain/ crystal, or a small amount of powder.
- vi) Cover the WE material with one of the provided (holed) current collectors. Use Al foil for excursions to potentials >1.5 V vs. Li/Li⁺, Cu foil for excursions to potentials between 0 and 3 V vs. Li/Li⁺.
- vii) Insert the upper O-ring seal into the cell body, and place the optical window on top. Make sure that the window is in the center position.
- viii) Attach the cell lid and fasten the three hex socket screws.
- ix) Attach the WE contact pin to port A.
- x) Attach the touch screw from below and raise it to the uppermost position; then turn the touch screw back (counter-clockwise) by about 30°.
- xi) Fill the cell with electrolyte according to the following procedure.
 1. Connect the provided transfer (fill) line to port B.
 2. Charge a 5 mL syringe with ca. 1 mL of electrolyte. **NOTE:** We recommend one-time use PP plastic syringes with low friction polysiloxane pistons.
 3. Connect the syringe to the Luer adapter of the transfer line.
 4. Pull the syringe piston back to evacuate the cell. Hold the piston a few seconds in the strained position.
 5. Release the piston so that the electrolyte is being drawn deliberately into the cell. **NOTE:** Never pressurize the cell during the filling procedure.
 6. Repeat the two previous steps to complete filling.
 7. Remove the transfer line and close port B with the provided plug. Optionally port B may be plugged with the second WE contact pin assembly.
- xii) Insert the cell into the stand.
- xiii) Connect the cell to your potentiostat/ galvanostat or battery tester via the 2 mm banana sockets.

6 X-ray Experiments

For X-ray experiments, the optional XRD Kit is available, part# ECC1-00-0156-B. The XRD-kit comprises a Beryllium window, part# ECC1-00-0222-A, and a modified cell lid, part# ECC1-00-0127-C. The cell lid features a 12 mm wide groove that allows for a viewing angle onto the sample surface as low as 8°.

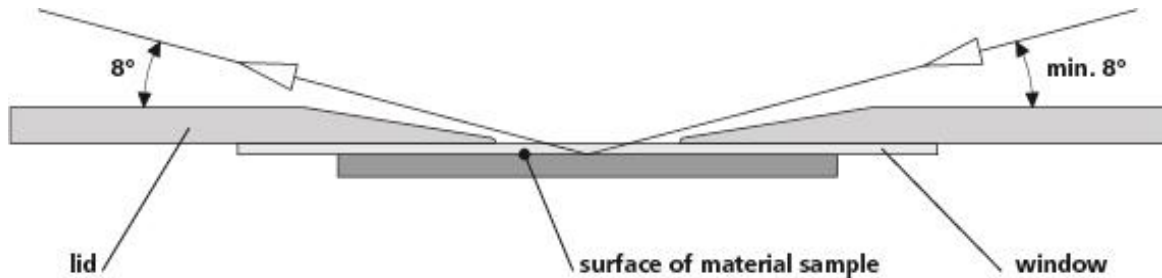

At very positive potentials, the Beryllium window may suffer from oxidation. In this case we recommend placing a thin insulation layer, e.g. a small piece of polyethylene foil (15 mm in diameter, 10 µm thick), in between the holed current collector and the Beryllium window.

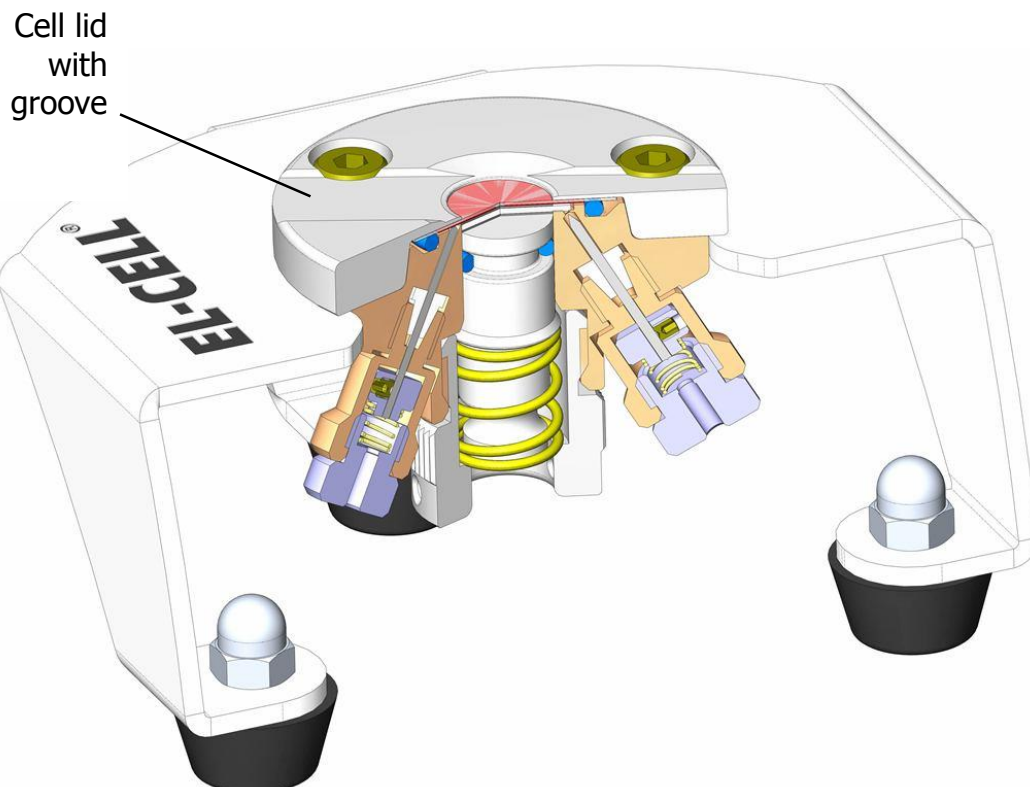

Beryllium is highly toxic and can cause cancer. Take proper precautions when handling the Beryllium window. Avoid direct contact with skin. Carefully collect and dispose properly any Beryllium fragments when accidentally breaking the window.



7 Disassembly and Cleaning

Right after use, disassemble the cell in the reverse order of assembly.

All chemicals used have to be disposed properly. All wetted parts are to be cleaned with water and/or other appropriate solvents. Ultrasonic cleaning is recommended except for the cell window. All parts are to be dried immediately after cleaning at 80°C.

NOTE: Leaving cell parts in contact with ambient atmosphere while still being wetted with electrolyte may result in severe corrosion.

8 Accessories and Spare Parts

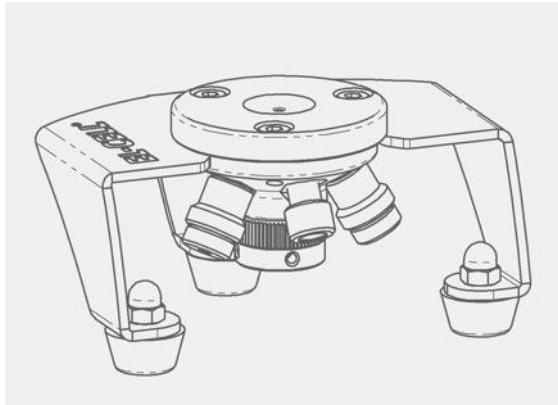

ECC-Opto-Std
ECC1-00-0150-A

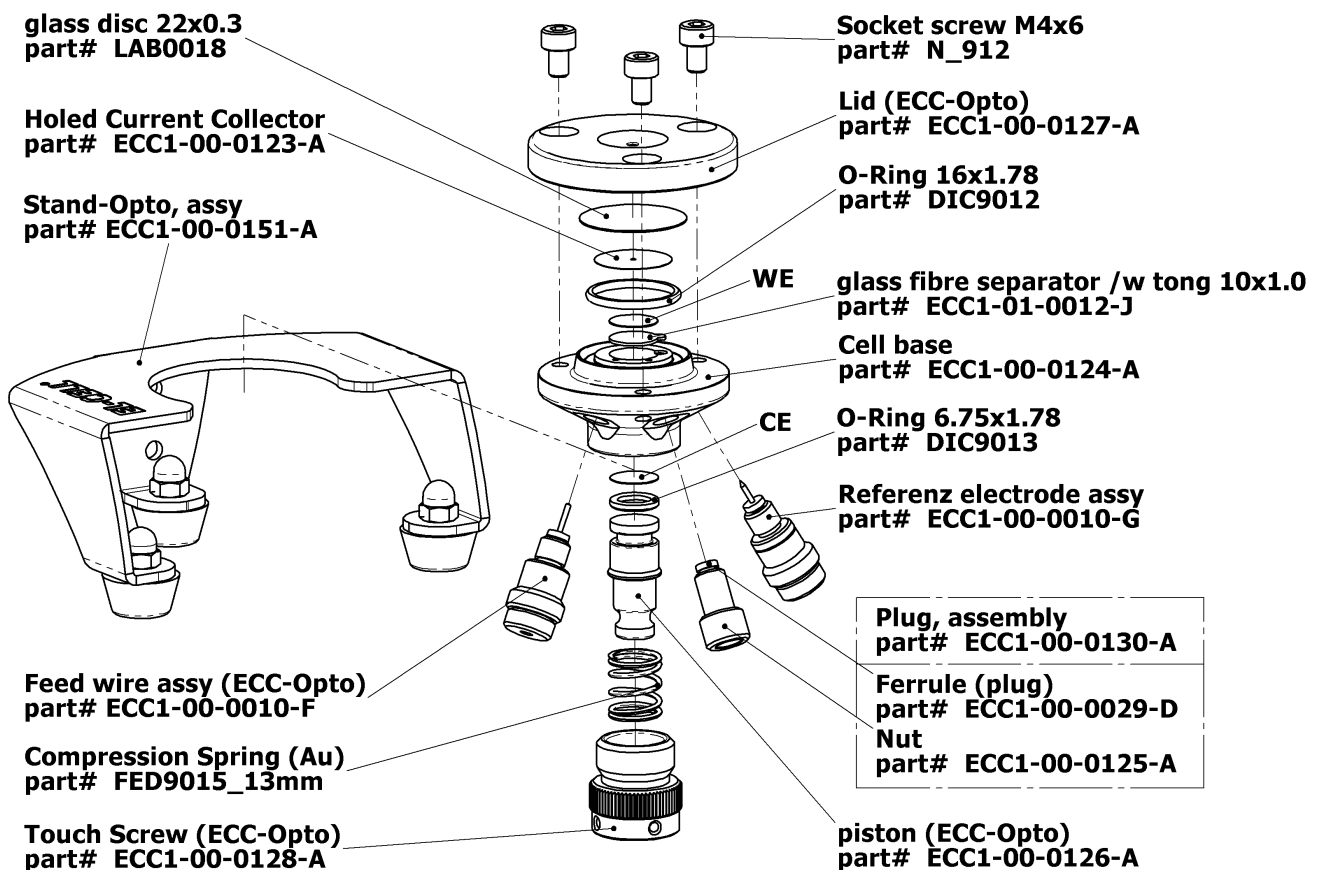

Window materials:

- Optical glass 22 mm x 0.3 mm (5 pcs), part# LAB0018/V
- Sapphire 22 mm x 0.3 mm (3 pcs), part# ECC1-00-0149-A
- Beryllium 22 mm x 0.2 mm (1 pc), part# ECC1-00-0222-A

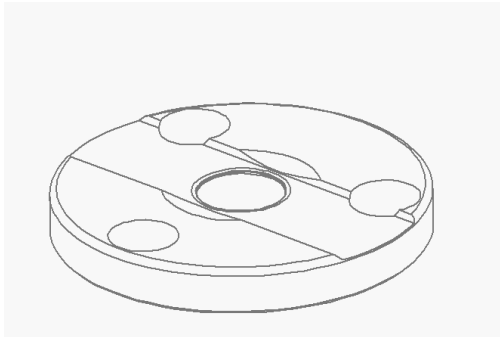

ECC-Opto XRD Kit
part# ECC1-00-0156-B

Lid (ECC-Opto) XRD
part# ECC1-00-0127-C

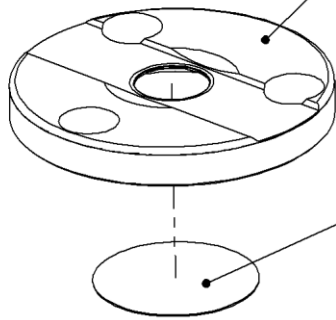

beryllium window
part# ECC1-00-0222-A



9 Technical Support

Technical support for this product is exclusively handled by EL-CELL GmbH. The following procedure must be followed when the ECC test cell or any part of it is returned to EL-CELL GmbH for repair:

1. Send an e-mail to info@el-cell.com to obtain a return authorization number and a decontamination report form.
2. Sign the decontamination report asserting that the instrument has been decontaminated and is safe for technicians to work on it.
3. Describe in detail what is wrong.
4. Include a contact name, address, telephone number and email address.
5. Return the equipment to

EL-CELL GmbH
Tempowerkring 8
D-21079 Hamburg
Germany
Email info@el-cell.com

10 Warranty

For a period of one year from the date of shipment, EL-CELL GmbH (hereinafter Seller) warrants the goods to be free from defect in material and workmanship to the original purchaser. During the warranty period, Seller agrees to repair or replace defective and/or nonconforming goods or parts without charge for material or labour, or, at the Seller's option, demand return of the goods and tender repayment of the price. Buyer's exclusive remedy is repair or replacement of defective and nonconforming goods, or, at Seller's option, the repayment of the price.

Seller excludes and disclaims any liability for lost profits, personal injury, interruption of service, or for consequential incidental or special damages arising out of, resulting from, or relating in any manner to these goods.

This Limited Warranty does not cover defects, damage, or nonconformity resulting from abuse, misuse, neglect, lack of reasonable care, modification, or the attachment of improper devices to the goods. This Limited Warranty does not cover expendable items. This warranty is void when repairs are performed by a non-authorized person or service centre. At Seller's option, repairs or replacements will be made on site or at the factory. If repairs or replacements are to be made at the factory, Buyer shall return the goods prepaid and bear all the risks of loss until delivered to the factory. If Seller returns the goods, they will be delivered prepaid and Seller will bear all risks of loss until delivery to Buyer. Buyer and Seller agree that this Limited Warranty shall be governed by and construed in accordance with the laws of Germany.

The warranties contained in this agreement are in lieu of all other warranties expressed or implied, including the warranties of merchantability and fitness for a particular purpose.

This Limited Warranty supersedes all prior proposals or representations oral or written and constitutes the entire understanding regarding the warranties made by Seller to Buyer. This Limited Warranty may not be expanded or modified except in writing signed by the parties hereto.