

Analog Input Module

ST-3xxx User Manual



Version 1.07

2013 CREVIS Co.,Ltd

DOCUMENT CHANGE SUMMARY				
REV	PAGE	REMARKS	DATE	EDITOR
1.0	New Document		2011/10/07	JE KANG
1.01	6	Add your experience Changed ST-3804, ST-3808, Module input wiring diagram	2012/1/13	JE KANG
1.02		Add the Certificate RoHS	2012/3/21	JE KANG
1.03		Deleted ST-3704, ST-3804 Type B Add ST-3704, ST-3804 PT100	2012/6/8	JE KANG
1.04	55	Add the Dimension	2013/2/22	JE KANG
1.05		ST-3804, ST-3808 module Add the "External PT100 Sensor"	2013/5/2	JE KANG
1.06		Environment Spec. 50°C→55°C (UL Temp)	2013/7/3	JE KANG
1.07		Changed Power Dissipation "ST-3118, ST-3428, ST-3218, ST-3474, ST-3544, ST-3644"	2013/7/17	JE KANG

Table of Contents

1. Important Notes	6
1.1. Safety Instruction	7
1.1.1. Symbols	7
1.1.2. Safety Notes	7
1.1.3. Certification	7
2. ANALOG INPUT MODULE LIST	8
3. Specification	9
3.1. The Interface and data	9
3.1.1. ST-3114	9
3.1.2. ST-3118	10
3.1.3. ST-3134	11
3.1.4. ST-3214	12
3.1.5. ST-3218	13
3.1.6. ST-3234	14
3.1.7. ST-3274	15
3.1.8. ST-3424	16
3.1.9. ST-3428	17
3.1.10. ST-3444	18
3.1.11. ST-3474	19
3.1.12. ST-3524	20
3.1.13. ST-3544	21
3.1.14. ST-3624	22

3.1.15.	ST-3644.....	23
3.1.16.	ST-3702.....	24
3.1.17.	ST-3704.....	26
3.1.18.	ST-3708.....	27
3.1.19.	ST-3802.....	28
3.1.20.	ST-3804.....	29
3.1.21.	ST-3808.....	30
3.2.	Environment Specification	30
3.3.	Specification	32
3.3.1.	ST-3114.....	32
3.3.2.	ST-3118.....	33
3.3.3.	ST-3134.....	34
3.3.4.	ST-3214.....	35
3.3.5.	ST-3218.....	36
3.3.6.	ST-3234.....	37
3.3.7.	ST-3274.....	38
3.3.8.	ST-3424.....	39
3.3.9.	ST-3428.....	40
3.3.10.	ST-3444.....	41
3.3.11.	ST-3474.....	42
3.3.12.	ST-3524.....	43
3.3.13.	ST-3544.....	44
3.3.14.	ST-3624.....	45

3.3.15.	ST-3644.....	46
3.3.16.	ST-3702.....	47
3.3.17.	ST-3704.....	48
3.3.18.	ST-3708.....	49
3.3.19.	ST-3802.....	50
3.3.20.	ST-3804.....	51
3.3.21.	ST-3808.....	52
4.	Dimension.....	53
4.1.	ST-3xx2, ST-3xx4, ST-3xx8.....	53
4.2.	ST-3704, ST-3708, ST-3804, ST-3808.....	54
4.3.	ST-3274, ST-3474.....	55
5.	Mapping Data into the image Table.....	56
5.1.	ST-3xx2.....	56
5.2.	ST-3xx4.....	56
5.3.	ST-3xx8.....	57
5.4.	ST-3274, ST-3474.....	58
6.	Trouble Shooting.....	59
6.1.	Normal Module.....	59
6.2.	ST-3704, ST-3708, ST-3804, ST-3808.....	60

1. Important Notes

Solid state equipment has operational characteristics differing from those of electromechanical equipment.

Safety Guidelines for the Application, Installation and Maintenance of Solid State Controls describes some important differences between solid state equipment and hard-wired electromechanical devices.

Because of this difference, and also because of the wide variety of uses for solid state equipment, all persons responsible for applying this equipment must satisfy themselves that each intended application of this equipment is acceptable.

In no event will CREVIS be responsible or liable for indirect or consequential damages resulting from the use or application of this equipment.

The examples and diagrams in this manual are included solely for illustrative purposes. Because of the many variables and requirements associated with any particular installation, CREVIS cannot assume responsibility or liability for actual use based on the examples and diagrams.

Warning!



- ✓ **If you don't follow the directions, it could cause a personal injury, damage to the equipment or explosion**
- Do not assemble the products and wire with power applied to the system. Else it may cause an electric arc, which can result into unexpected and potentially dangerous action by field devices. Arching is explosion risk in hazardous locations. Be sure that the area is non-hazardous or remove system power appropriately before assembling or wiring the modules.
- Do not touch any terminal blocks or IO modules when system is running. Else it may cause the unit to an electric shock or malfunction.
- Keep away from the strange metallic materials not related to the unit and wiring works should be controlled by the electric expert engineer. Else it may cause the unit to a fire, electric shock or malfunction.

Caution!

- ✓ **If you disobey the instructions, there may be possibility of personal injury, damage to equipment or explosion. Please follow below Instructions.**
- Check the rated voltage and terminal array before wiring. Avoid the circumstances over 55°C of temperature. Avoid placing it directly in the sunlight.
- Avoid the place under circumstances over 85% of humidity.
- Do not place Modules near by the inflammable material. Else it may cause a fire.
- Do not permit any vibration approaching it directly.
- Go through module specification carefully, ensure inputs, output connections are made with the specifications. Use standard cables for wiring.
- Use Product under pollution degree 2 environment.

1.1. Safety Instruction

1.1.1. Symbols

<p>DANGER</p> 	<p>Identifies information about practices or circumstances that can cause an explosion in a hazardous environment, which may lead to personal injury or death property damage, or economic loss</p>
<p>IMPORTANT</p>	<p>Identifies information that is critical for successful application and understanding of the product</p>
<p>ATTENTION</p> 	<p>Identifies information about practices or circumstances that can lead to personal Injury, property damage, or economic loss. Attentions help you to identity a hazard, avoid a hazard, and recognize the consequences</p>

1.1.2. Safety Notes

<p>DANGER</p> 	<p>The modules are equipped with electronic components that may be destroyed by electrostatic discharge. When handling the modules, ensure that the environment (persons, workplace and packing) is well grounded. Avoid touching conductive components, e.g. FnBUS Pin.</p>
--	--

1.1.3. Certification

c-UL-us UL Listed Industrial Control Equipment, certified for U.S. and Canada

See UL File E235505

DNV CERTIFICATE No. A-10666

CE Certificate

EN 61000-6-2; Industrial Immunity

EN 61000-6-4; Industrial Emissions

RoHS (EU, CHINA)

2. ANALOG INPUT MODULE LIST

ST-Number	Description	ID(hex)	Production Status
ST-3114	4 Channels, Current, 0~20mA, 12bit	41 43 1C	Active
ST-3118	8 Channels, Current, 0~20mA, 12bit	41 47 82	Active
ST-3134	4 Channels, Current, 0~20mA, 14bit	41 43 1E	Active
ST-3214	4 Channels, Current, 4~20mA, 12bit	41 43 1D	Active
ST-3218	8 Channels, Current, 4~20mA, 12bit	41 47 83	Active
ST-3234	4 Channels, Current, 4~20mA, 14bit	41 43 1F	Active
ST-3274	4 Channels, Current, 4~20mA, 12bit, Sensor Connector	41 43 A3	Active
ST-3424	4 Channels, Voltage, 0~10Vdc, 12bit	41 43 20	Active
ST-3428	8 Channels, Voltage, 0~10Vdc, 12bit	41 47 22	Active
ST-3444	4 Channels, Voltage, 0~10Vdc, 14bit	41 43 22	Active
ST-3474	4 Channels, Voltage, 0~10Vdc, 12bit, Sensor Connector	41 43 A0	Active
ST-3524	4 Channels, Voltage, -10Vdc~10Vdc, 12bit	41 43 21	Active
ST-3544	4 Channels, Voltage, -10Vdc~10Vdc, 14bit	41 43 23	Active
ST-3624	4 Channels, Voltage, 0~5Vdc, 12bit	41 43 24	Active
ST-3644	4 Channels, Voltage, 0~5Vdc, 14bit	41 43 25	Active
ST-3702	2 Channels, RTD, Status	41 41 28	Active
ST-3704	4 Channels, RTD, Status	41 43 64	Active
ST-3708	8 Channels, RTD, Status	41 47 65	Active
ST-3802	2 Channels, TC	41 41 2A	Active
ST-3804	4 Channels, TC	41 43 66	Active
ST-3808	8 Channels, TC	41 47 67	Active

3. Specification

3.1. The Interface and data

3.1.1. ST-3114

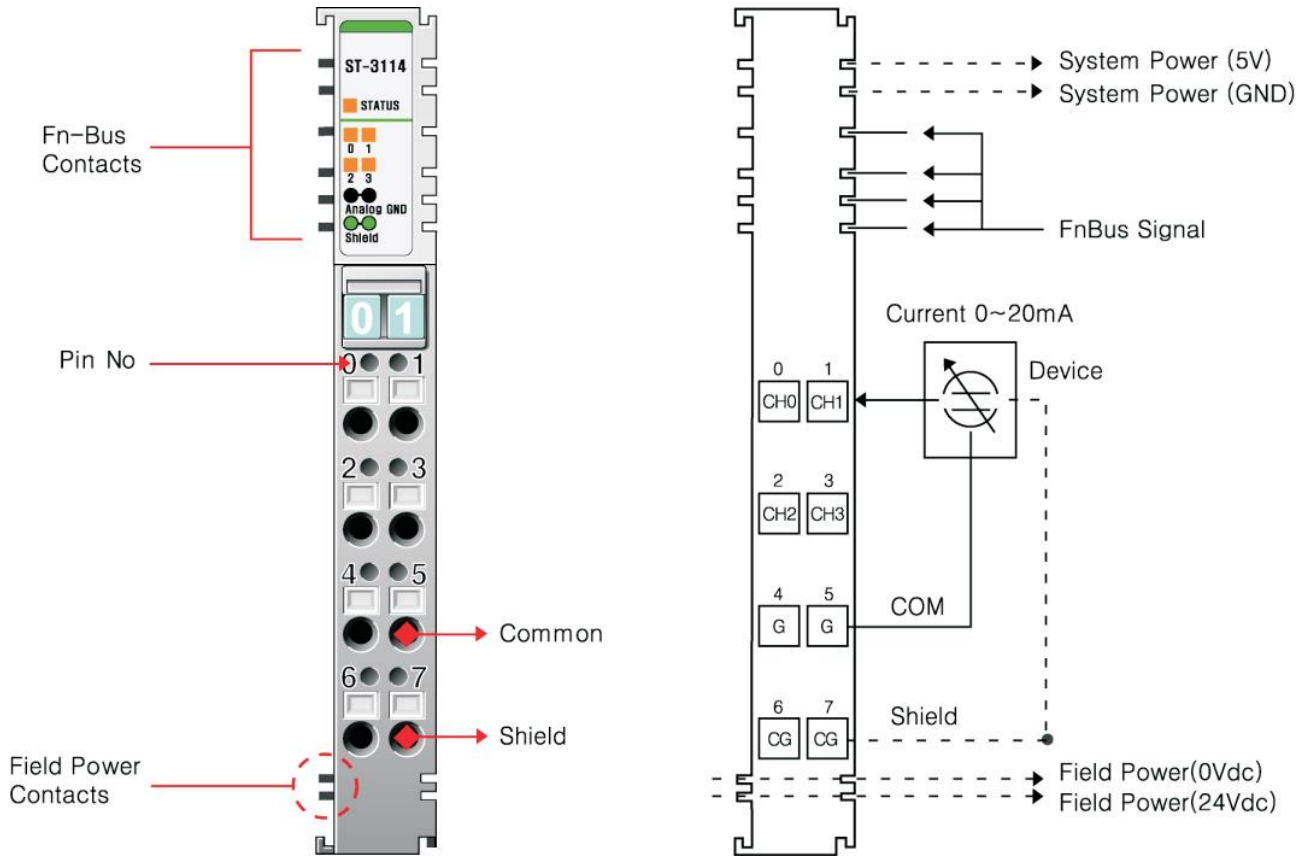

Pin No.	Description	Pin No.	Description
0	Input Channel 0	1	Input Channel 1
2	Input Channel 2	3	Input Channel 3
4	Input Channel Common (0V)	5	Input Channel Common (0V)
6	Chassis Ground / Shield	7	Chassis Ground / Shield

Current	0.0mA	5.0mA	10.0mA	20.0mA
Data(Hex)	H 0000	H 03FF	H 07FF	H 0FFF

3.1.2. ST-3118

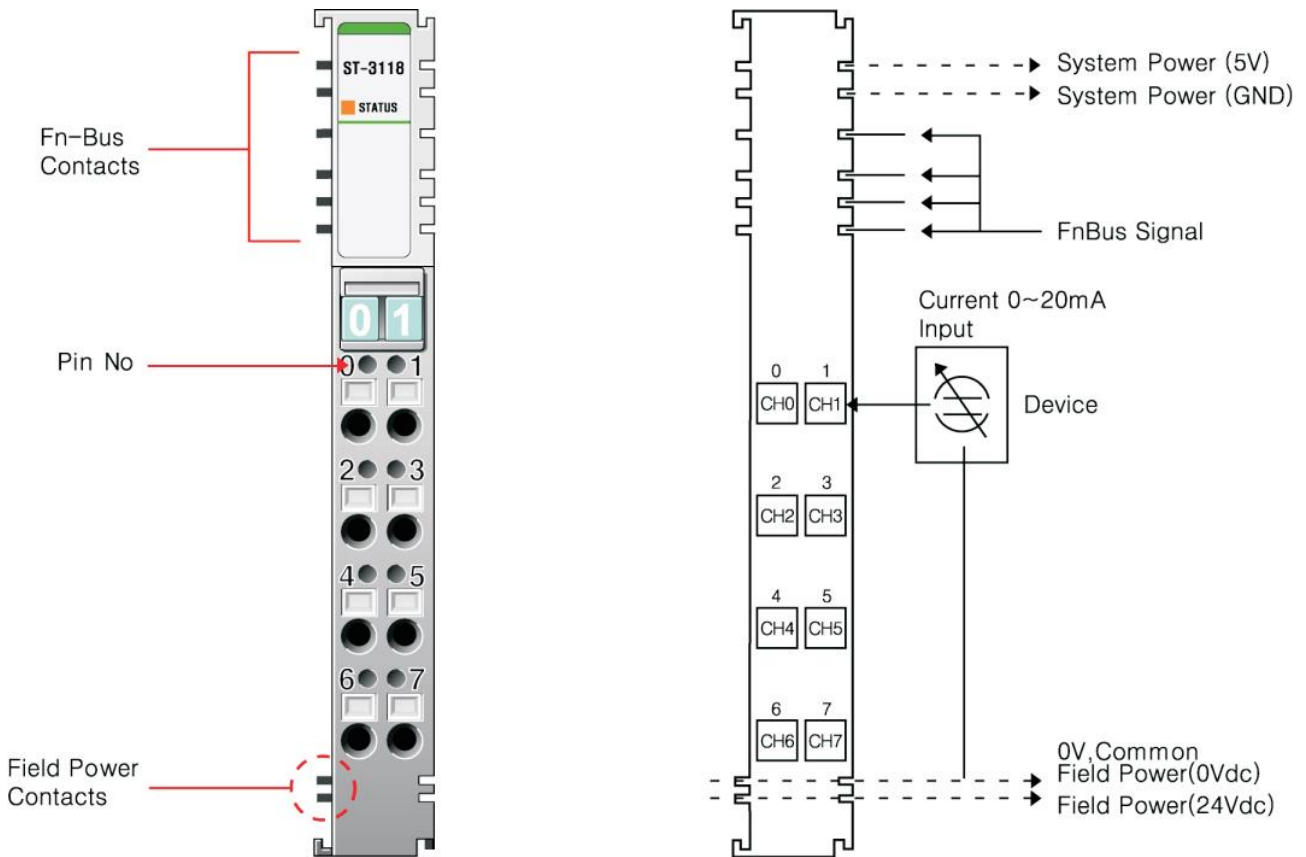

Pin No.	Description	Pin No.	Description
0	Input Channel 0	1	Input Channel 1
2	Input Channel 2	3	Input Channel 3
4	Input Channel 4	5	Input Channel 5
6	Input Channel 6	7	Input Channel 7

Current	0.0mA	5.0mA	10.0mA	20.0mA
Data(Hex)	H 0000	H 03FF	H 07FF	H 0FFF

3.1.3. ST-3134

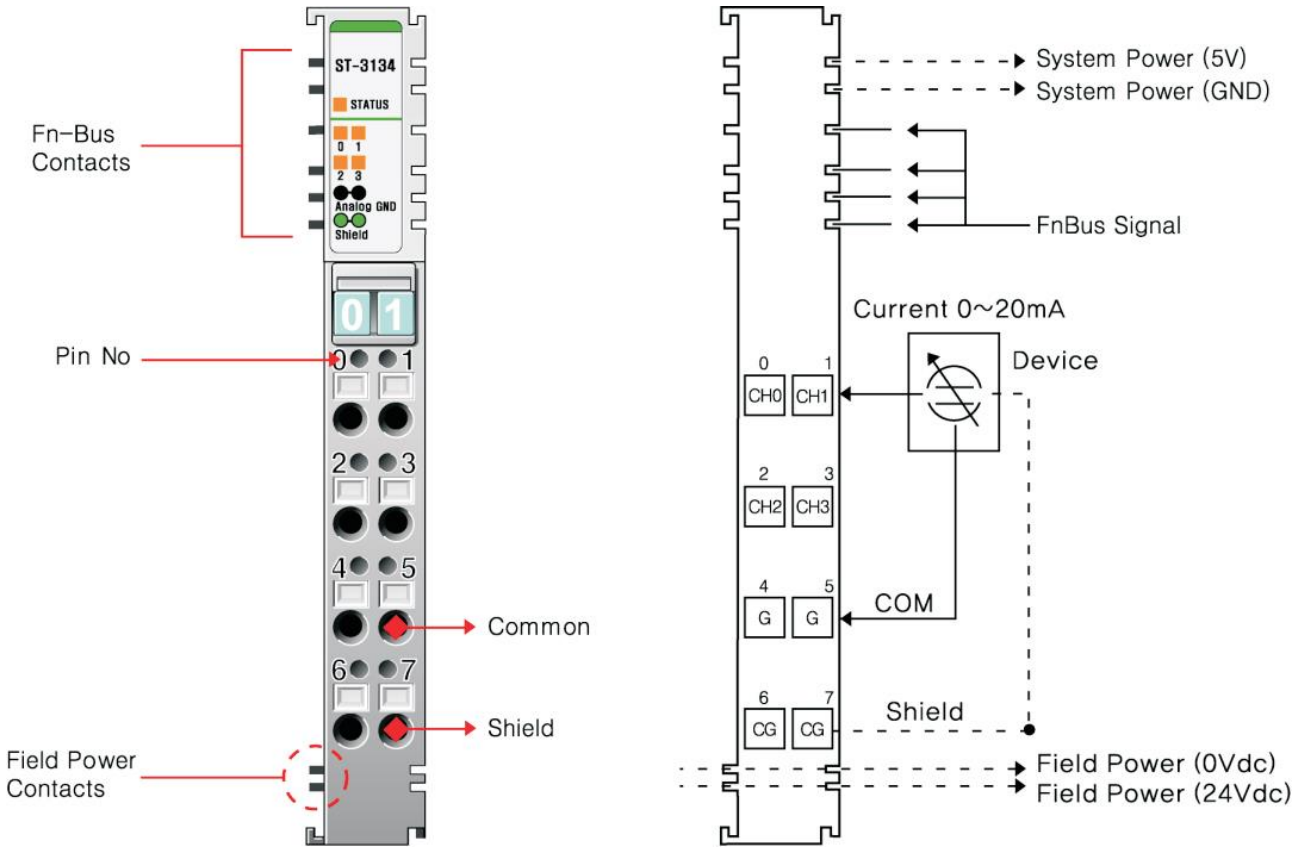

Pin No.	Description	Pin No.	Description
0	Input Channel 0	1	Input Channel 1
2	Input Channel 2	3	Input Channel 3
4	Input Channel Common (0V)	5	Input Channel Common (0V)
6	Chassis Ground / Shield	7	Chassis Ground / Shield

Current	0.0mA	5.0mA	10.0mA	20.0mA
Data(Hex)	H 0000	H 0FFF	H 1FFF	H 3FFF

3.1.4. ST-3214

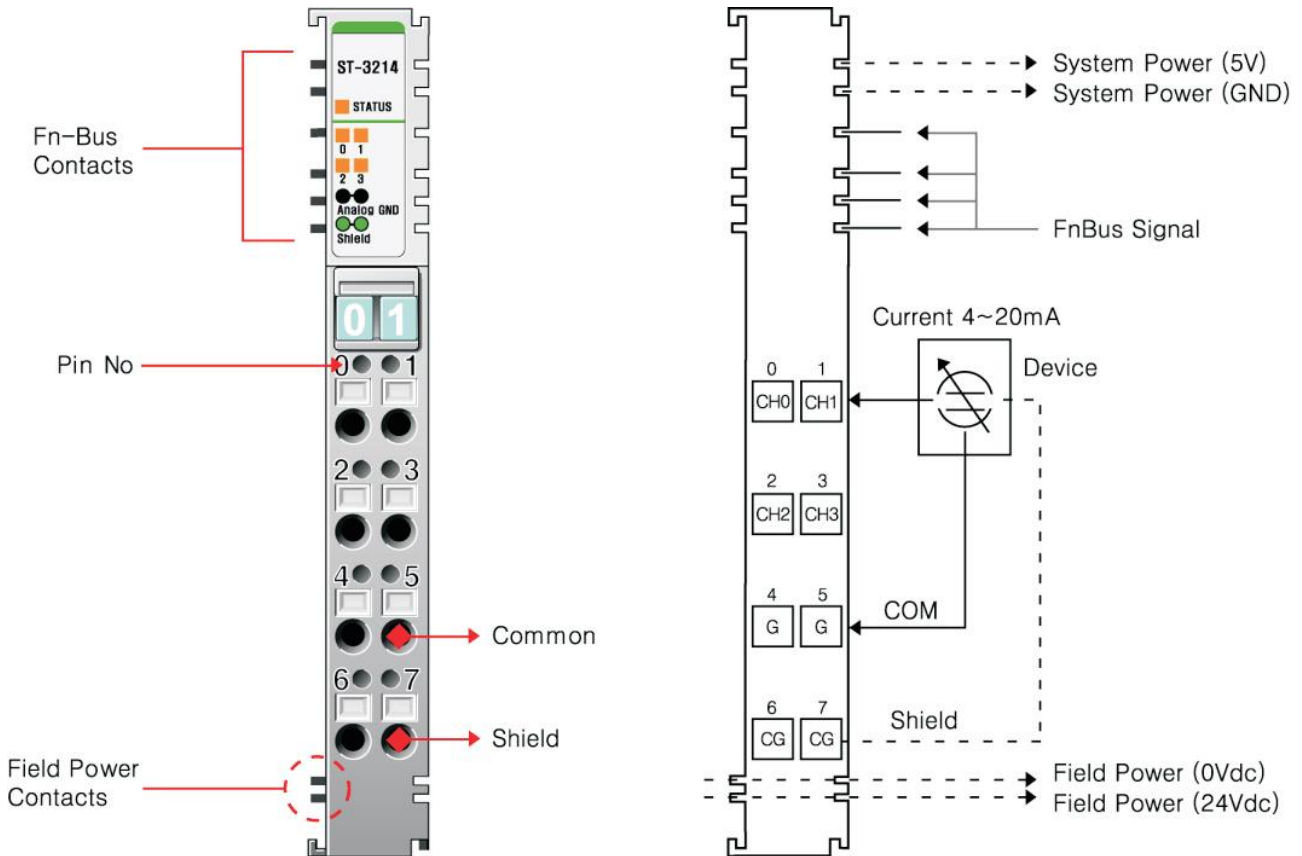

Pin No.	Description	Pin No.	Description
0	Input Channel 0	1	Input Channel 1
2	Input Channel 2	3	Input Channel 3
4	Input Channel Common (0V)	5	Input Channel Common (0V)
6	Chassis Ground / Shield	7	Chassis Ground / Shield

Current	3.0mA	4.0mA	5.0mA	10.0mA	20.0mA
Data(Hex)	H 8000	H 0000	H 00FF	H 05FF	H 0FFF

3.1.5. ST-3218

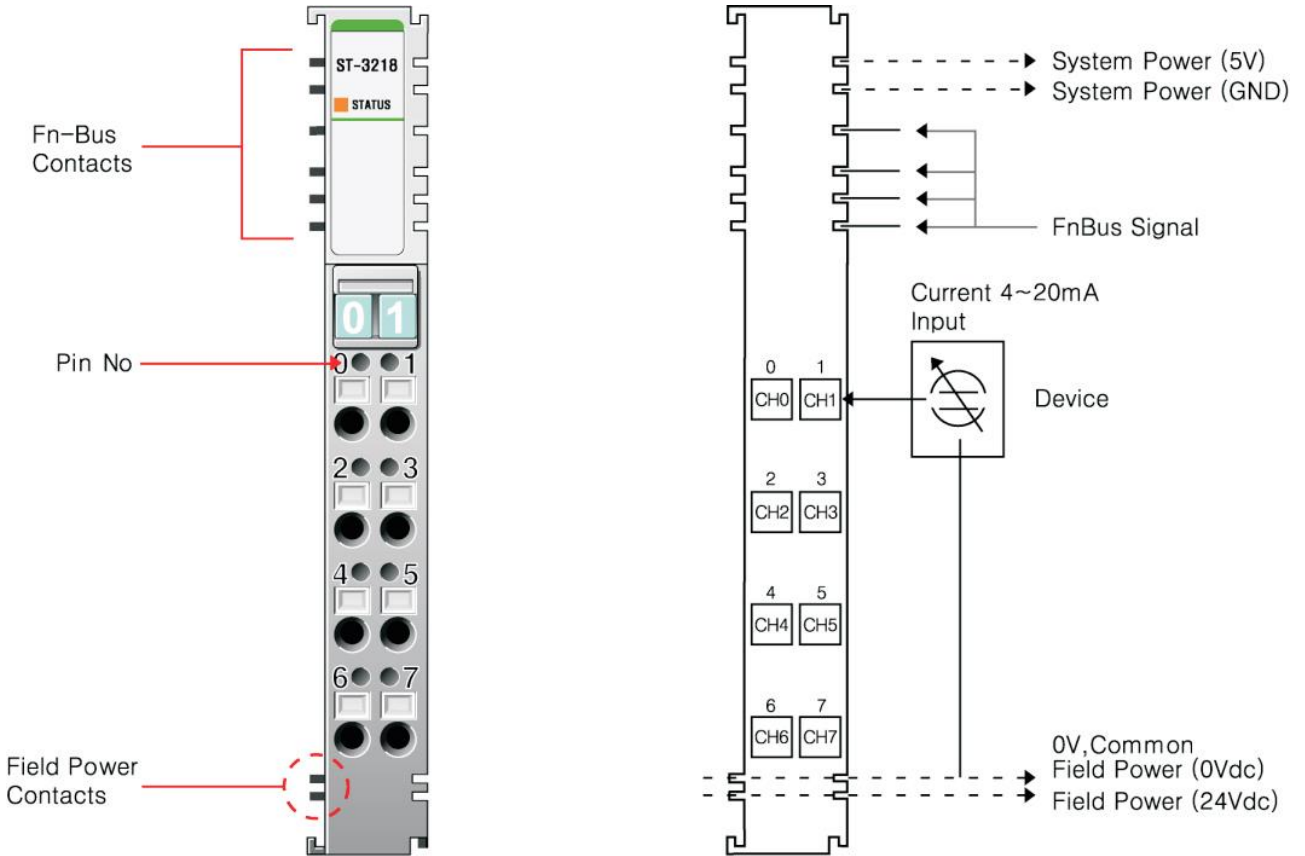

Pin No.	Description	Pin No.	Description
0	Input Channel 0	1	Input Channel 1
2	Input Channel 2	3	Input Channel 3
4	Input Channel 4	5	Input Channel 5
6	Input Channel 6	7	Input Channel 7

Current	3.0mA	4.0mA	12.0mA	20.0mA
Data(Hex)	H 8000	H 0000	H 07FF	H 0FFF

3.1.6. ST-3234

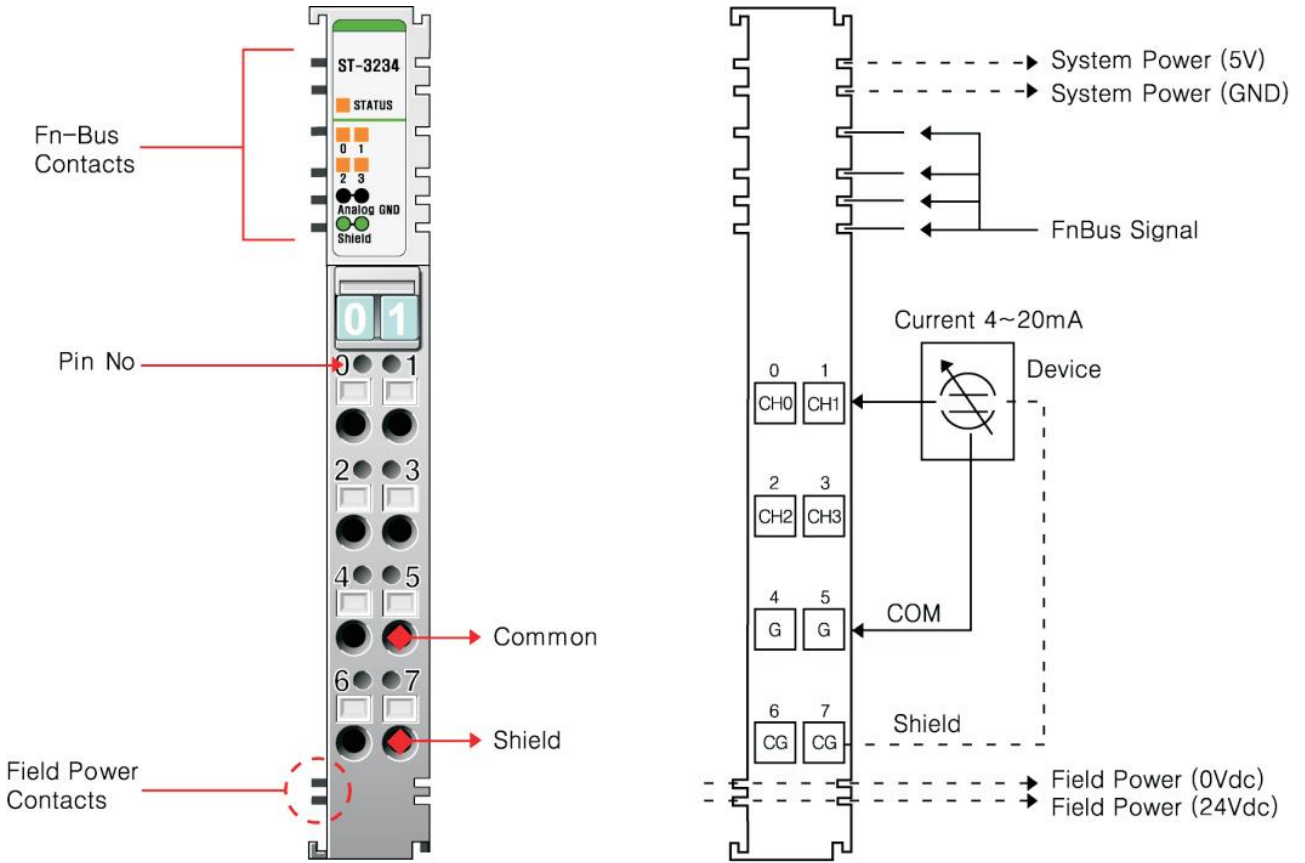

Pin No.	Description	Pin No.	Description
0	Input Channel 0	1	Input Channel 1
2	Input Channel 2	3	Input Channel 3
4	Input Channel Common (0V)	5	Input Channel Common (0V)
6	Chassis Ground / Shield	7	Chassis Ground / Shield

Current	3.0mA	4.0mA	5.0mA	10.0mA	20.0mA
Data(Hex)	H 8000	H 0000	H 03FF	H 17FF	H 3FFF

3.1.7. ST-3274

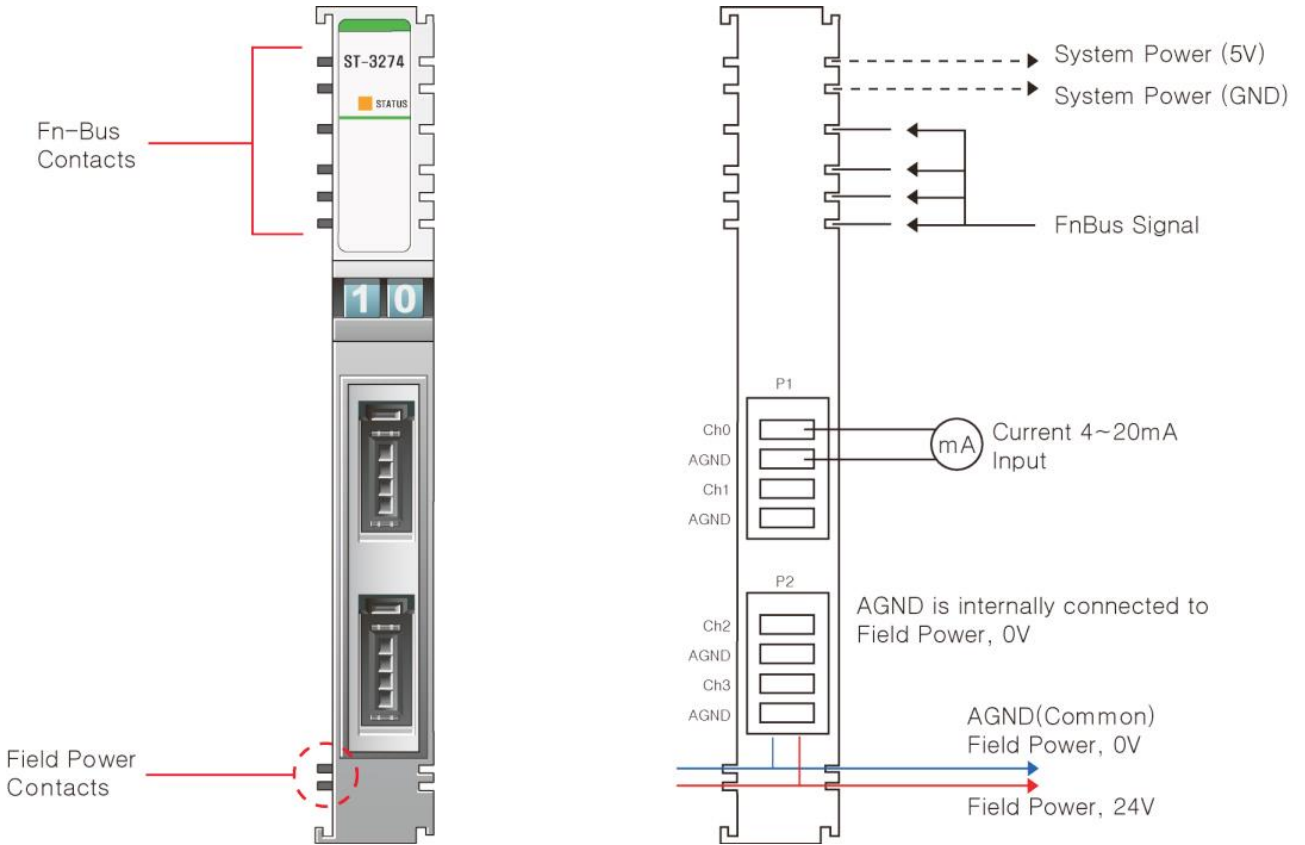

P1 Connector (Upper Connector)

P2 Connector (Lower Connector)

Pin No.	Description	Pin No.	Description
1	Input Channel 0	1	Input Channel 2
2	Field Power 0V(AGND), Common	2	Field Power 0V(AGND), Common
3	Input Channel 1	3	Input Channel 3
4	Field Power 0V(AGND), Common	4	Field Power 0V(AGND), Common

Current	<3.0mA	4.0mA	12.0mA	20.0mA	20.4mA<
Data(Hex)	H 8000	H 0000	H 07FF	H 0FFF	H 7FFF

3.1.8. ST-3424

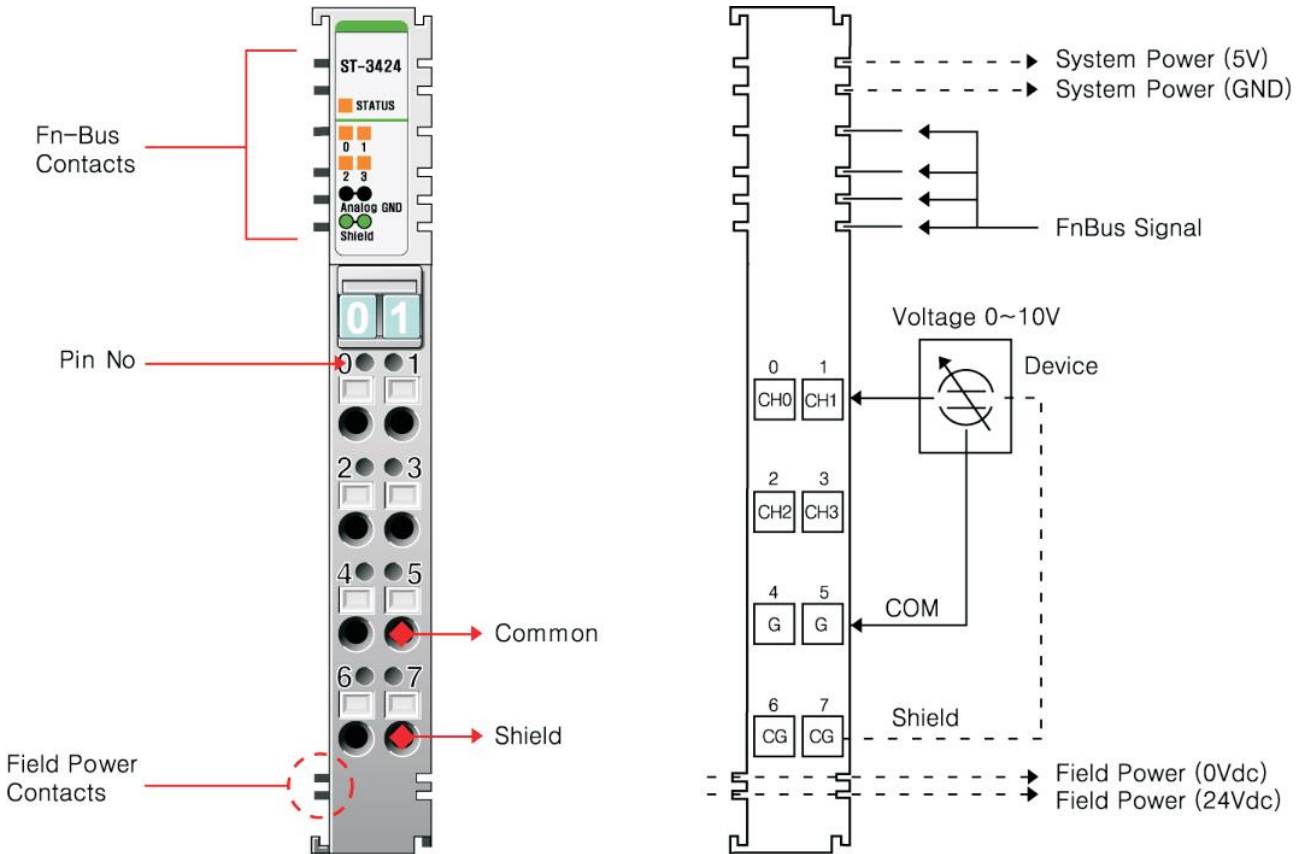

Pin No.	Description	Pin No.	Description
0	Input Channel 0	1	Input Channel 1
2	Input Channel 2	3	Input Channel 3
4	Input Channel Common (0V)	5	Input Channel Common (0V)
6	Chassis Ground / Shield	7	Chassis Ground / Shield

Voltage	0V	2.5V	5V	10V
Data(Hex)	H 0000	H 03FF	H 07FF	H 0FFF

3.1.9. ST-3428

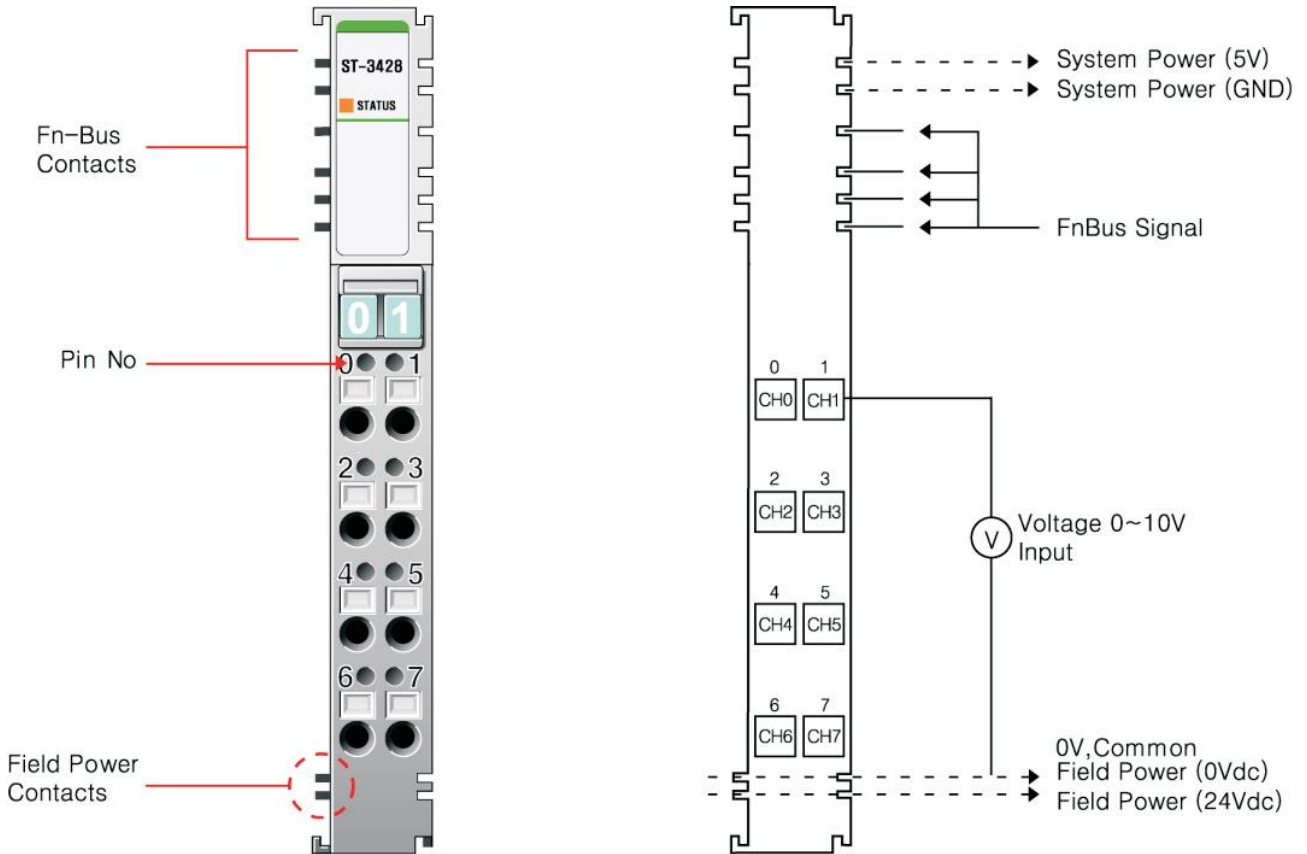

Pin No.	Description	Pin No.	Description
0	Input Channel 0	1	Input Channel 1
2	Input Channel 2	3	Input Channel 3
4	Input Channel 4	5	Input Channel 5
6	Input Channel 6	7	Input Channel 7

Voltage	0V	2.5V	5V	10V
Data(Hex)	H 0000	H 03FF	H 07FF	H 0FFF

3.1.10. ST-3444

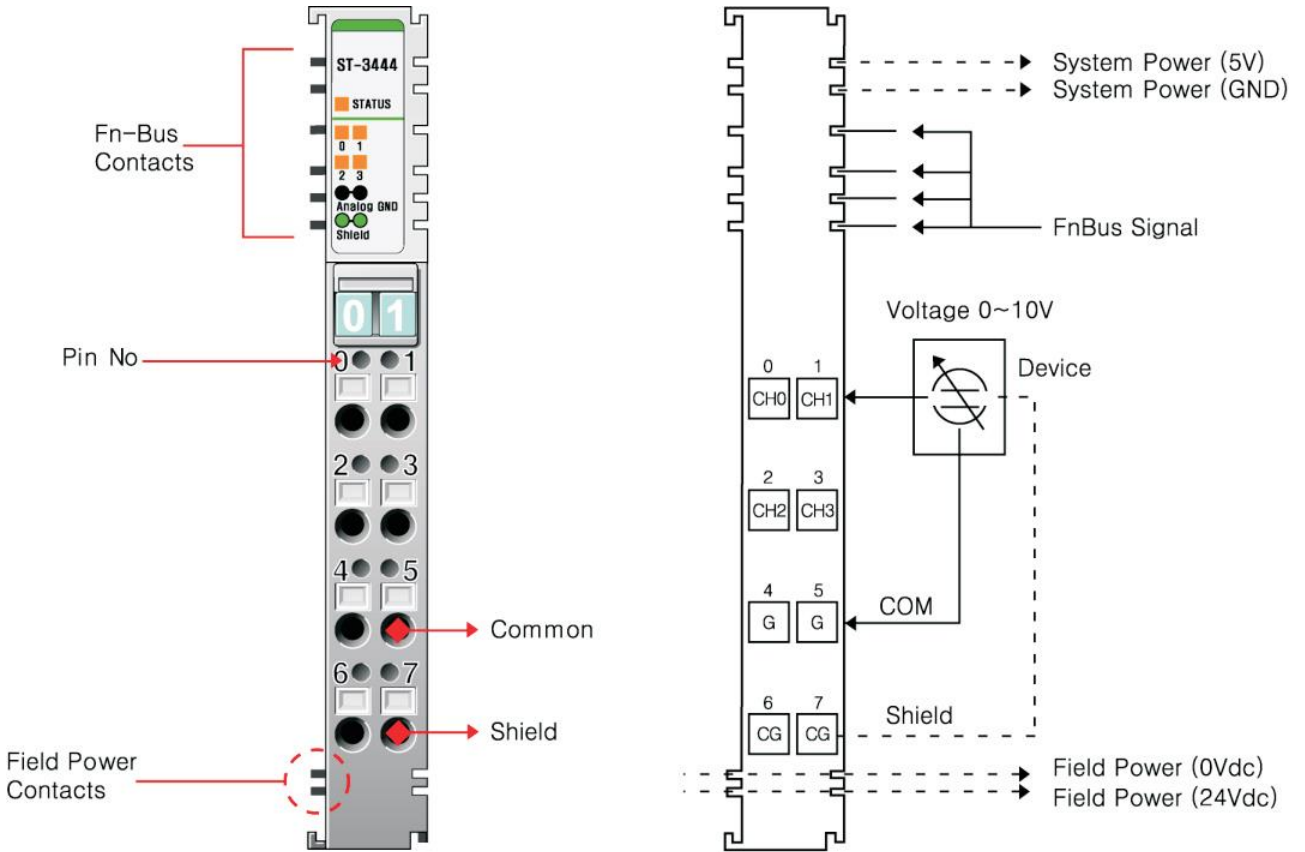

Pin No.	Description	Pin No.	Description
0	Input Channel 0	1	Input Channel 1
2	Input Channel 2	3	Input Channel 3
4	Input Channel Common (0V)	5	Input Channel Common (0V)
6	Chassis Ground / Shield	7	Chassis Ground / Shield

Voltage	0V	2V	5V	10V
Data(Hex)	H 0000	H 0CCC	H 1FFF	H 3FFF

3.1.11. ST-3474

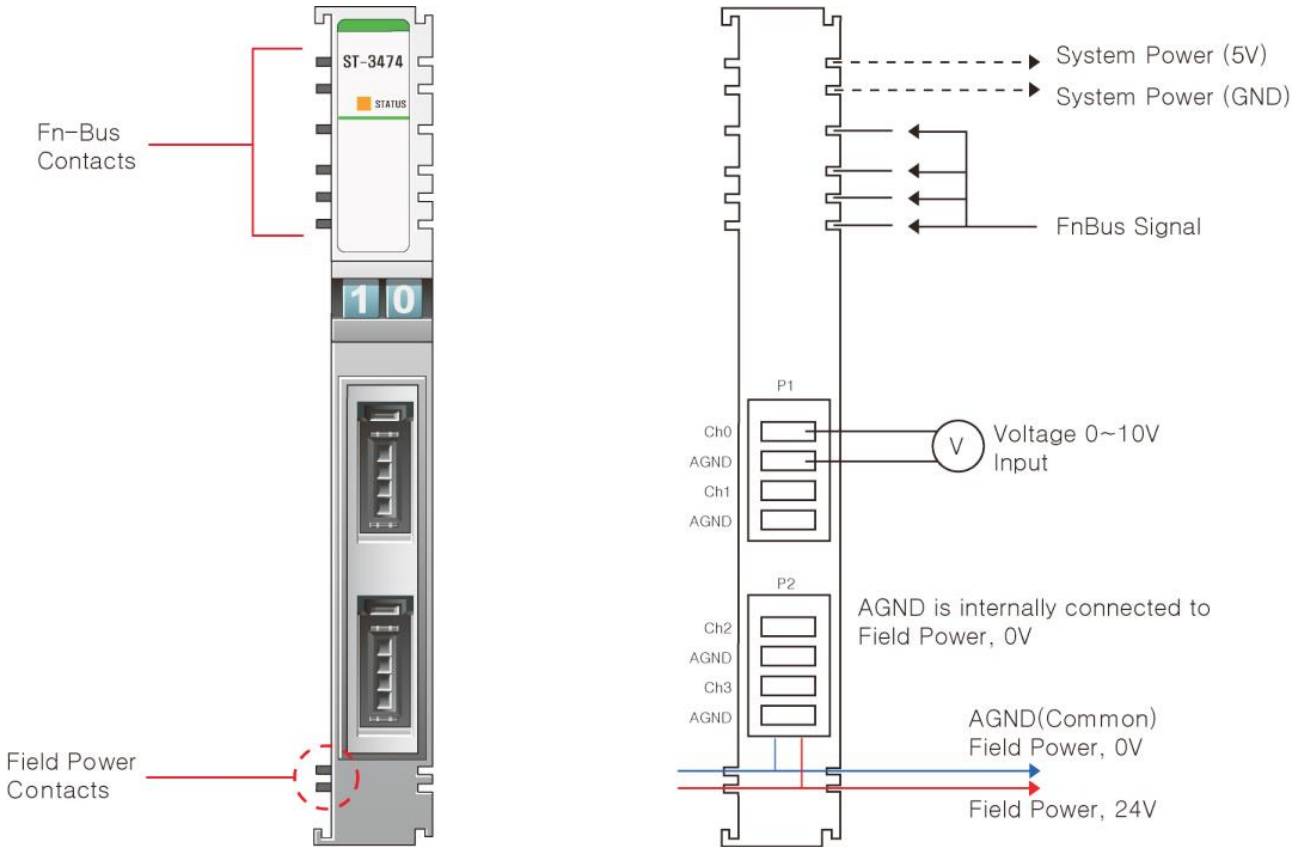

P1 Connector (Upper Connector)

P2 Connector (Lower Connector)

Pin No.	Description	Pin No.	Description
1	Input Channel 0	1	Input Channel 2
2	Field Power 0V(AGND), Common	2	Field Power 0V(AGND), Common
3	Input Channel 1	3	Input Channel 3
4	Field Power 0V(AGND), Common	4	Field Power 0V(AGND), Common

Voltage	0V	2.5V	5V	10V
Data(Hex)	H 0000	H 03FF	H 07FF	H 0FFF

3.1.12. ST-3524

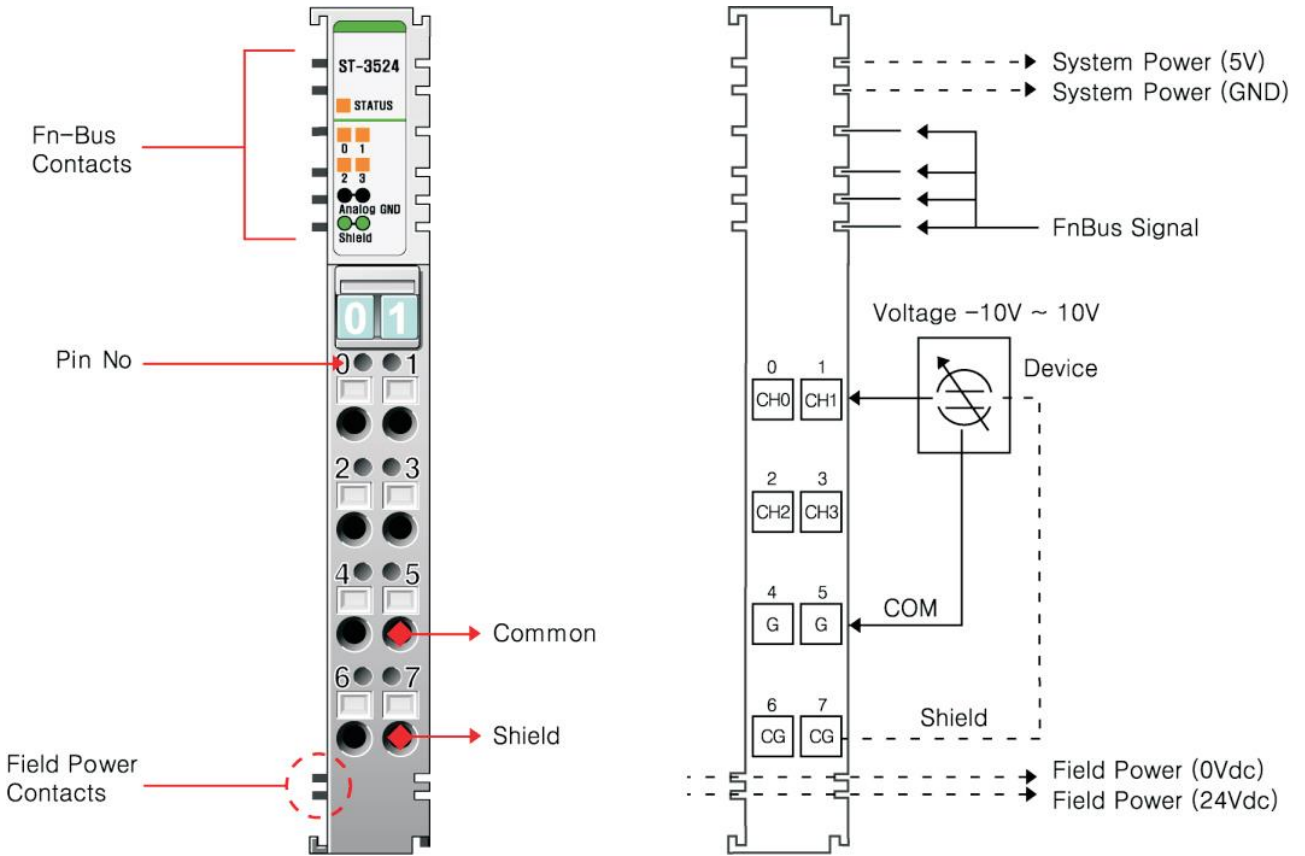

Pin No.	Description	Pin No.	Description
0	Input Channel 0	1	Input Channel 1
2	Input Channel 2	3	Input Channel 3
4	Input Channel Common (0V)	5	Input Channel Common (0V)
6	Chassis Ground / Shield	7	Chassis Ground / Shield

Voltage	-10V	-5V	0V	5V	10V
Data(Hex)	H F800	H FC00	H 0000	H 03FF	H 07FF

3.1.13. ST-3544

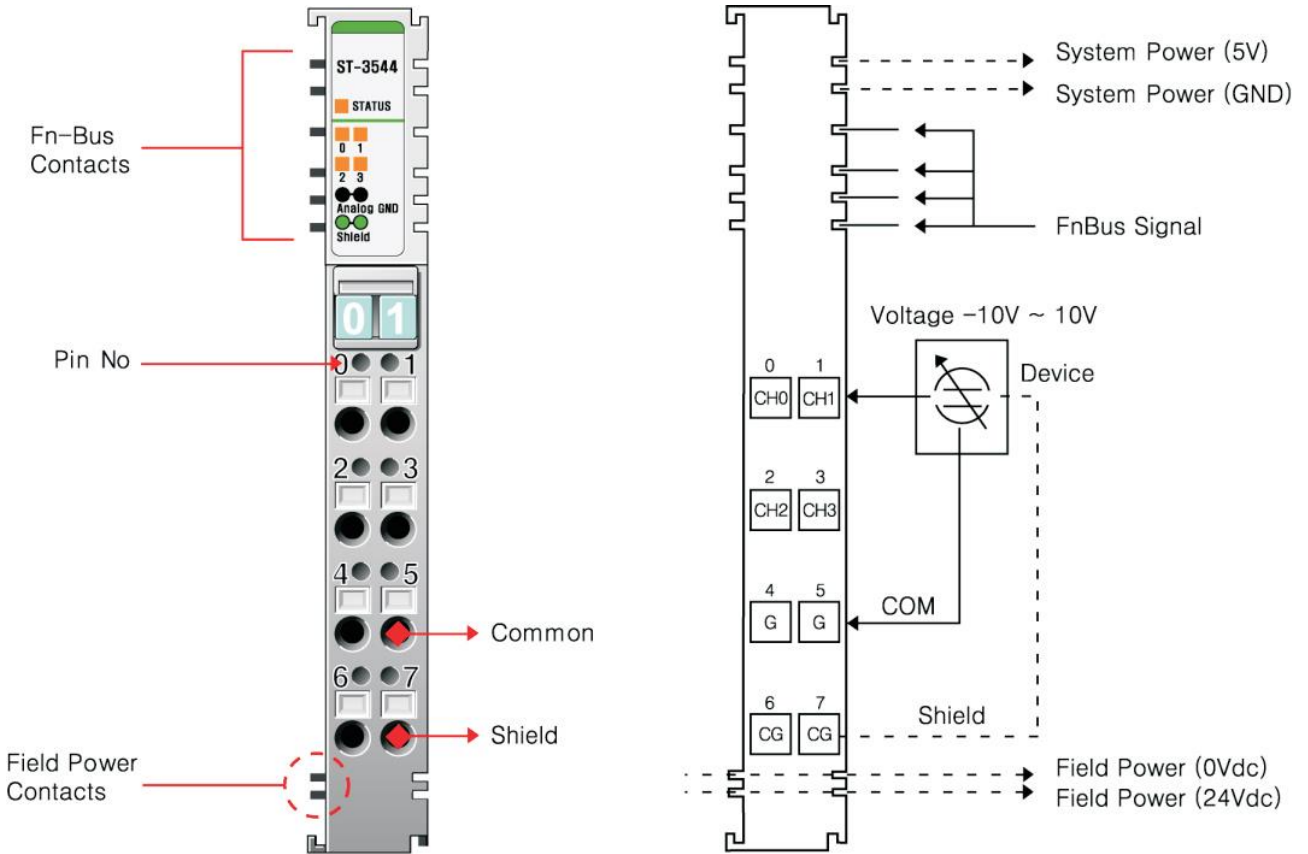

Pin No.	Description	Pin No.	Description
0	Input Channel 0	1	Input Channel 1
2	Input Channel 2	3	Input Channel 3
4	Input Channel Common (0V)	5	Input Channel Common (0V)
6	Chassis Ground / Shield	7	Chassis Ground / Shield

Voltage	-10V	-5V	0V	5V	10V
Data(Hex)	H E000	H F000	H 0000	H 0FFF	H 1FFF

3.1.14. ST-3624

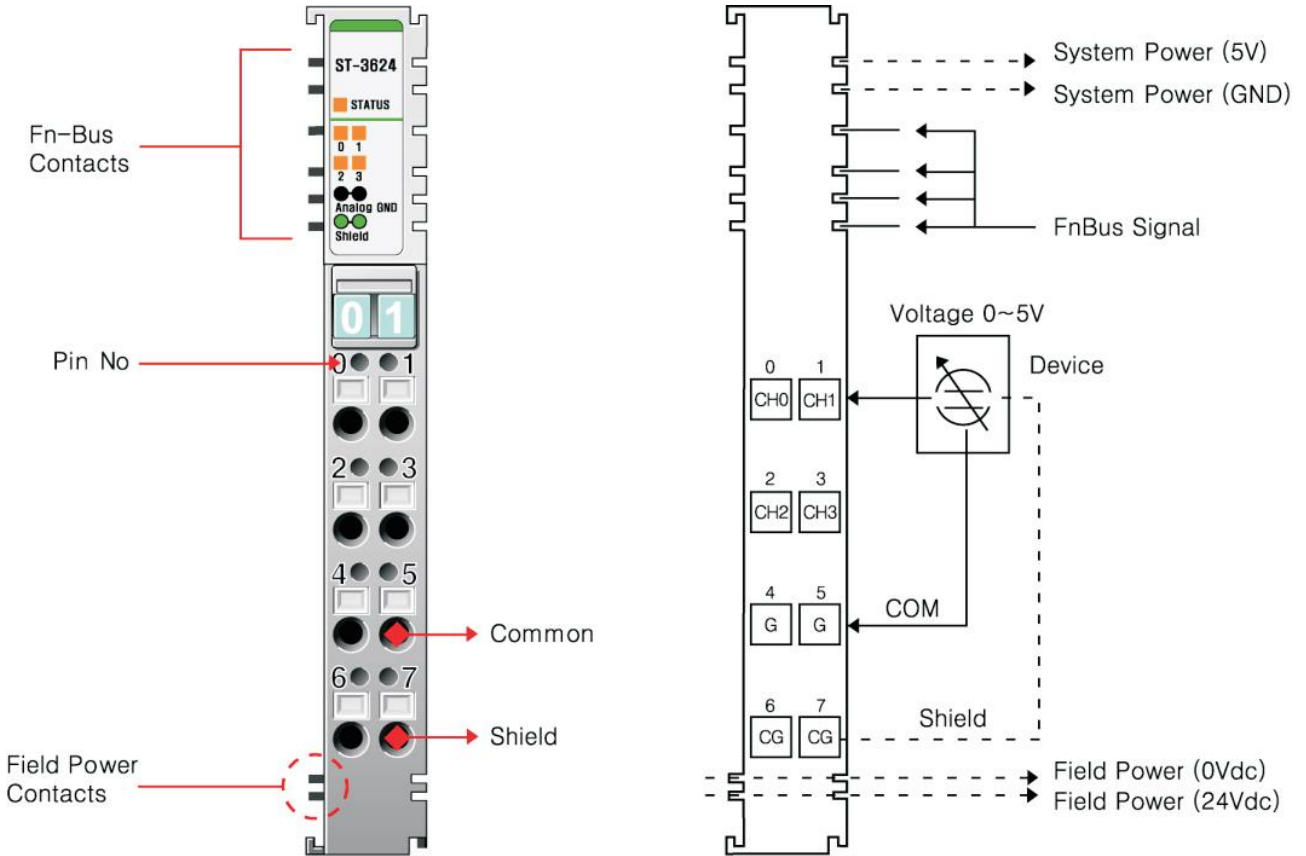

Pin No.	Description	Pin No.	Description
0	Input Channel 0	1	Input Channel 1
2	Input Channel 2	3	Input Channel 3
4	Input Channel Common (0V)	5	Input Channel Common (0V)
6	Chassis Ground / Shield	7	Chassis Ground / Shield

Voltage	0V	2V	4V	5V
Data(Hex)	H 0000	H 0666	H 0CCC	H 0FFF

3.1.15. ST-3644

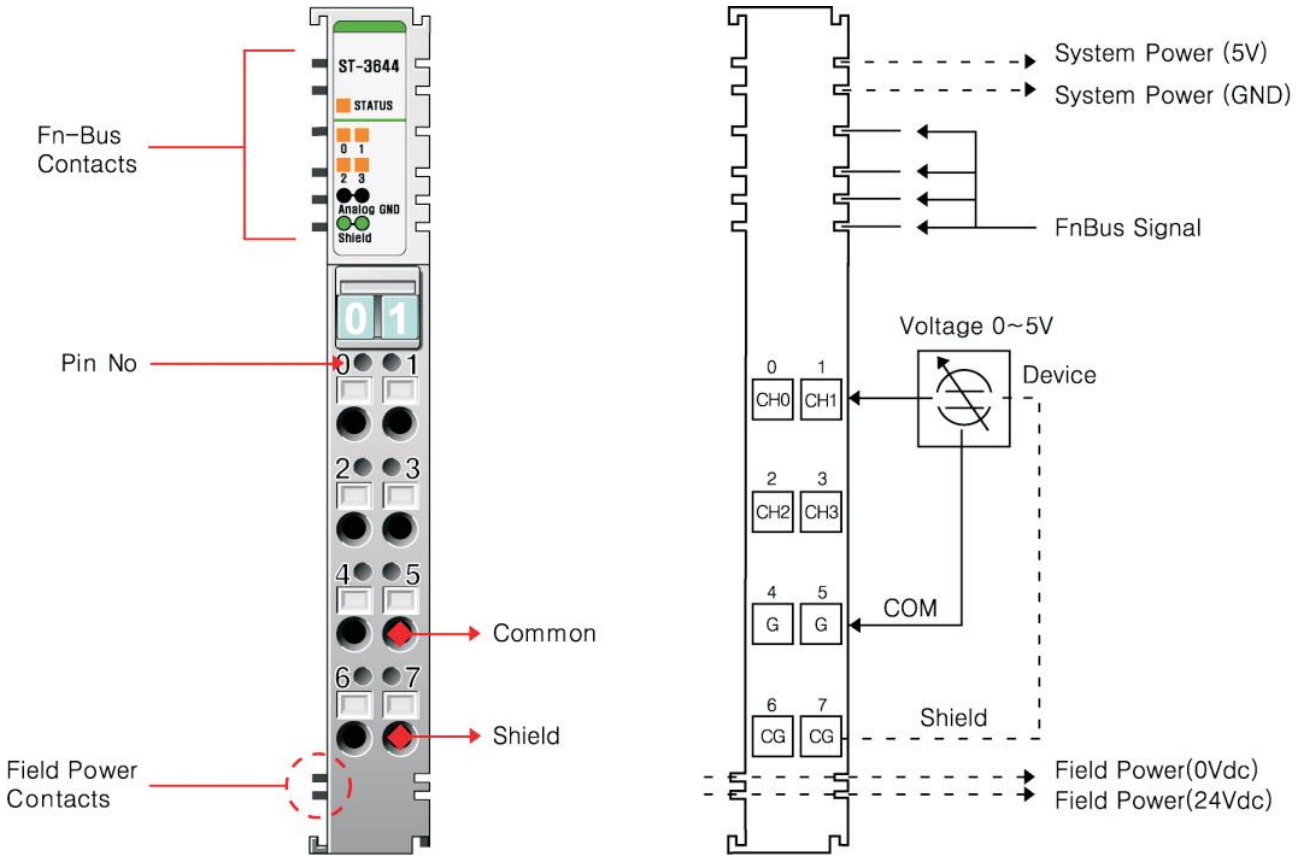

Pin No.	Description	Pin No.	Description
0	Input Channel 0	1	Input Channel 1
2	Input Channel 2	3	Input Channel 3
4	Input Channel Common (0V)	5	Input Channel Common (0V)
6	Chassis Ground / Shield	7	Chassis Ground / Shield

Voltage	0V	2V	4V	5V
Data(Hex)	H 0000	H 1999	H 3332	H 3FFF

3.1.16. ST-3702

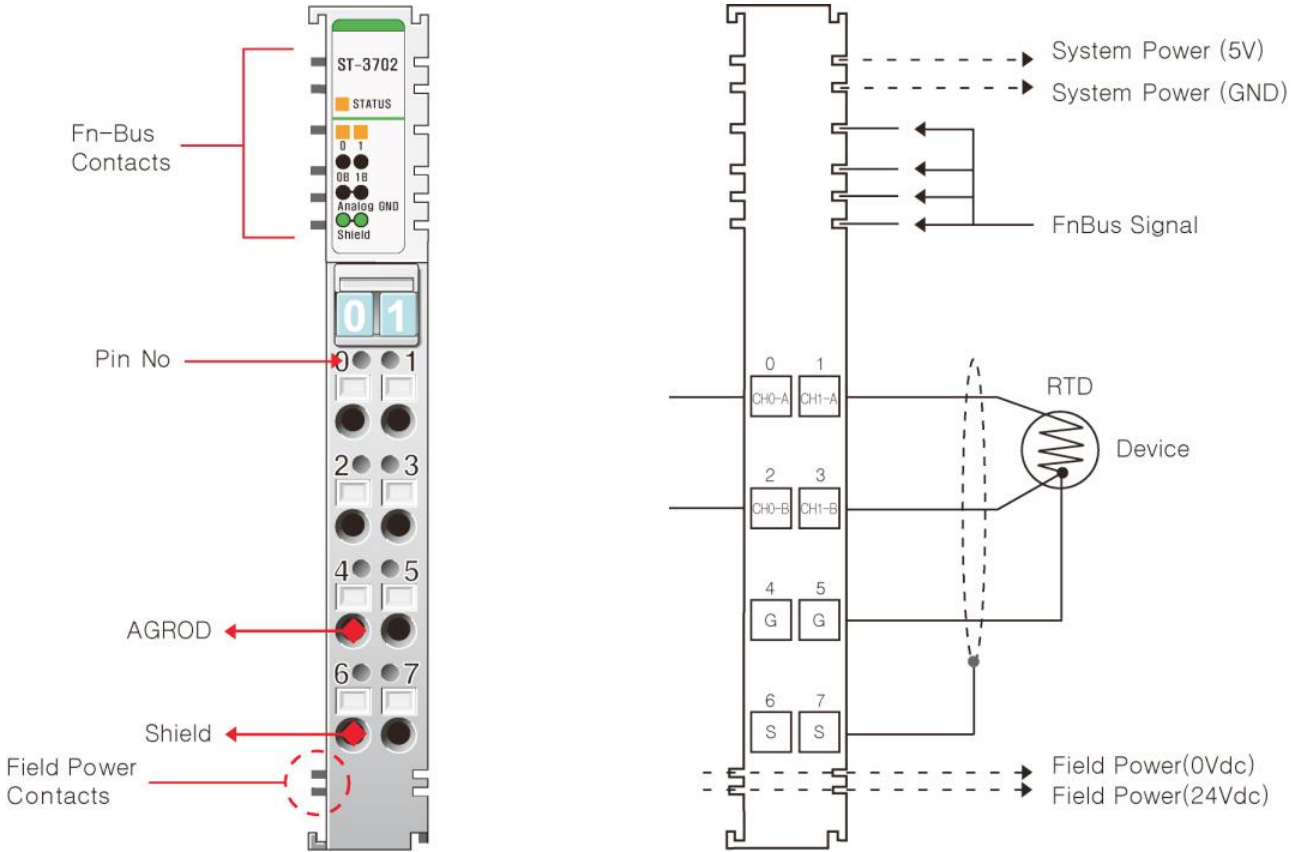

Pin No.	Description	Pin No.	Description
0	Input Channel 0_A	1	Input Channel 1_A
2	Input Channel 0_B	3	Input Channel 1_B
4	Analog Ground	5	Analog Ground
6	Shield	7	Shield

Resistance	100mΩ	0Ω	500Ω	1000Ω	1500Ω	2000Ω		
Data(Hex)		H 0000	H 1388	H 2710	H 3A98	H 4E20		
Sensor	PT100	-200℃	-100℃	0℃	200℃	400℃	600℃	850℃
Data(Hex)		H F830	H FC18	H 0000	H 07D0	H 0FA0	H 1770	H 2134
Sensor	JPT100	-200℃	-100℃	0℃	200℃	400℃	640℃	
Data(Hex)		H F830	H FC18	H 0000	H 07D0	H 0FA0	H 1900	

Sensor Type Data

Sensor Type	Degree	Counts	Resolution
Resistance 100mΩ	1~2000Ω	10~20000	100mΩ / 1count
Resistance 10mΩ	1~327Ω	10~3270	10mΩ / 1count
Resistance 20mΩ	1~620Ω	10~6200	20mΩ / 1count
PT50, 0.00385	200~850℃	-2000~8500	0.1℃ or 0.1°F / count
PT100, 0.00385	-200~850℃	-2000~8500	0.1℃ or 0.1°F / count
PT200, 0.00385	-200~850℃	-2000~8500	0.1℃ or 0.1°F / count
PT500, 0.00385	-200~850℃	-2000~8500	0.1℃ or 0.1°F / count
PT1000, 0.00385	-200~350℃	-2000~3500	0.1℃ or 0.1°F / count
JPT100, 0.003916	-200~640℃	-2000~6400	0.1℃ or 0.1°F / count
JPT200, 0.003916	-200~640℃	-2000~6400	0.1℃ or 0.1°F / count
JPT500, 0.003916	-200~640℃	-2000~6400	0.1℃ or 0.1°F / count
JPT1000, 0.003916	-200~350℃	-2000~3500	0.1℃ or 0.1°F / count
NI100, 0.00618	-60~250℃	-600~2500	0.1℃ or 0.1°F / count
NI120, 0.00672	-80~250℃	-800~2500	0.1℃ or 0.1°F / count
NI200, 0.00618	-60~250℃	-600~2500	0.1℃ or 0.1°F / count
NI500, 0.00618	-60~250℃	-600~2500	0.1℃ or 0.1°F / count
NI1000, 0.00618	-60~180℃	-600~1800	0.1℃ or 0.1°F / count
CU10, 0.00427	-200~260℃	-2000~2600	0.1℃ or 0.1°F / count

3.1.17. ST-3704

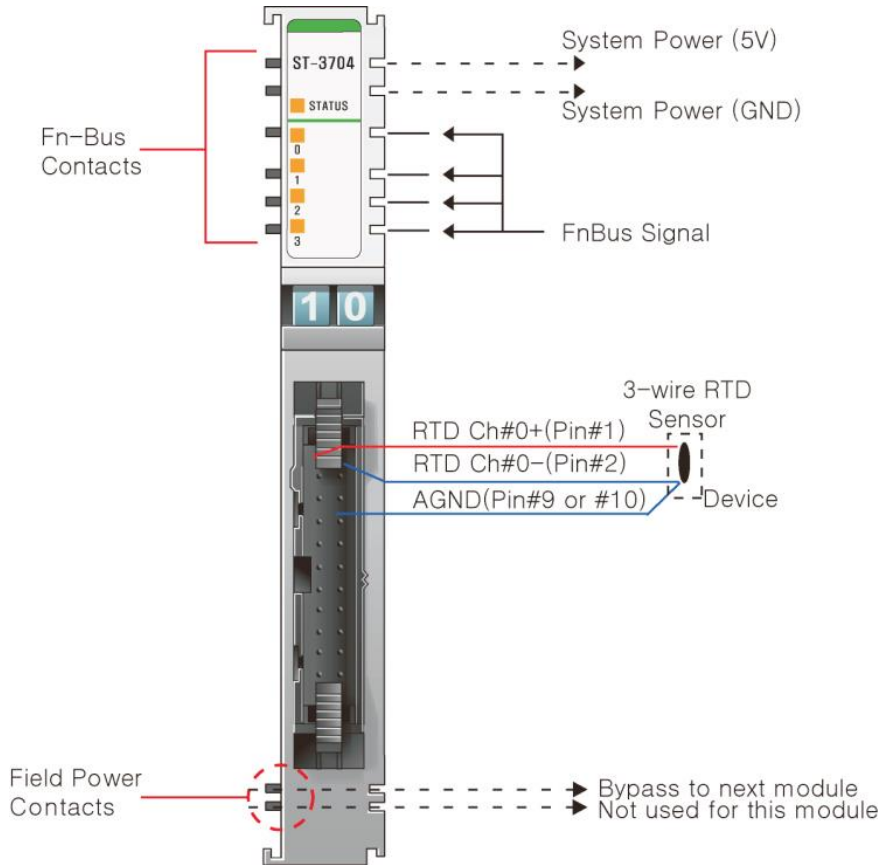

Pin No.	Description	Pin No.	Description
1	RTD Ch#0+	2	RTD Ch#0-
3	RTD Ch#1+	4	RTD Ch#1-
5	RTD Ch#2+	6	RTD Ch#2-
7	RTD Ch#3+	8	RTD Ch#3-
9	AGND	10	AGND
11	-	12	-
13	-	14	-
15	-	16	-
17	-	18	-
19	AGND	20	AGND

PT100

Sensor PT100	-200℃	-100℃	0℃	200℃	400℃	600℃	850℃
Data(Hex)	H F830	H FC18	H 0000	H 07D0	H 0FA0	H 1770	H 2134

3.1.18. ST-3708

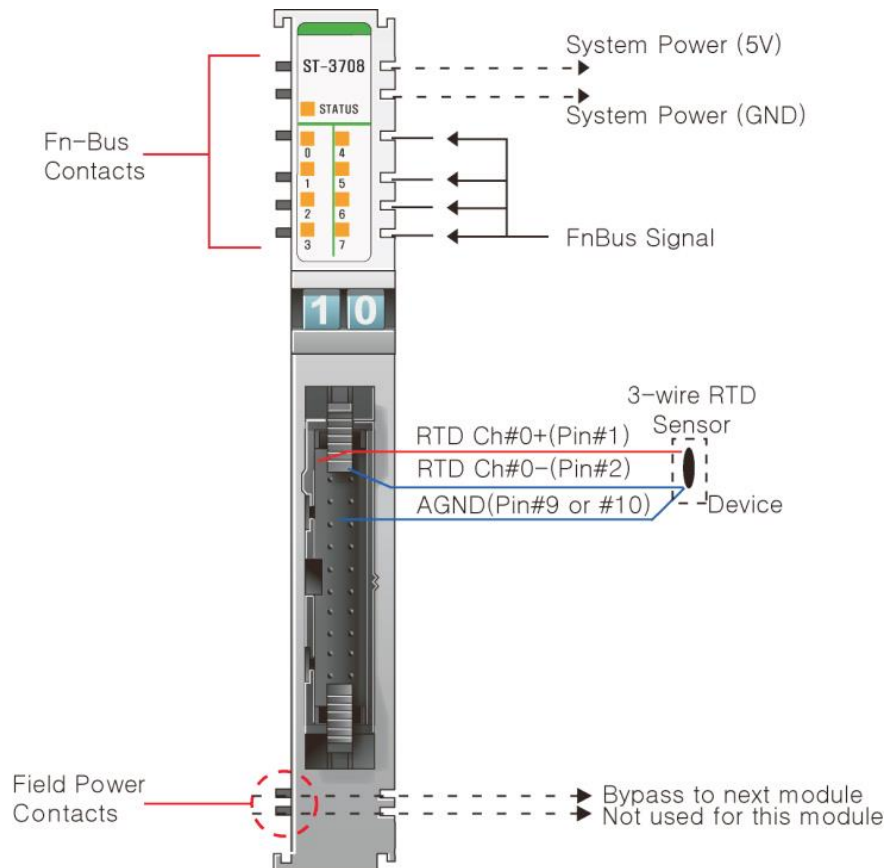

Pin No.	Description	Pin No.	Description
1	RTD Ch#0+	2	RTD Ch#0-
3	RTD Ch#1+	4	RTD Ch#1-
5	RTD Ch#2+	6	RTD Ch#2-
7	RTD Ch#3+	8	RTD Ch#3-
9	AGND	10	AGND
11	RTD Ch#4+	2	RTD Ch#4-
13	RTD Ch#5+	4	RTD Ch#5-
15	RTD Ch#6+	6	RTD Ch#6-
17	RTD Ch#7+	8	RTD Ch#7-
19	AGND	20	AGND

PT100

Sensor PT100	-200°C	-100°C	0°C	200°C	400°C	600°C	850°C
Data(Hex)	H F830	H FC18	H 0000	H 07D0	H 0FA0	H 1770	H 2134

3.1.19. ST-3802

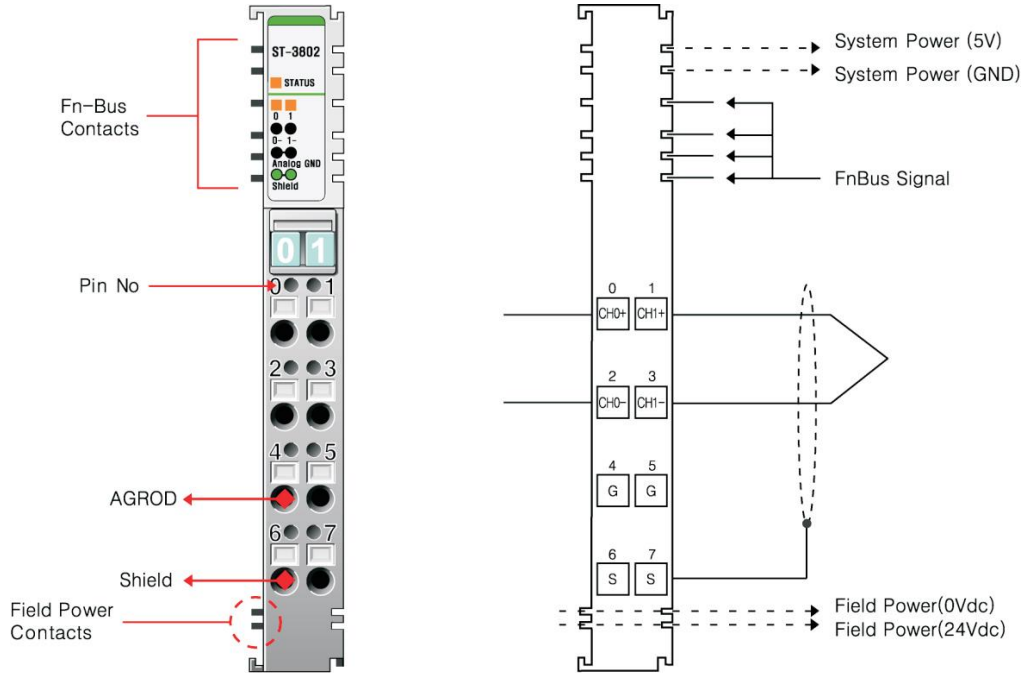

Pin No.	Description	Pin No.	Description
0	Input Channel 0+	1	Input Channel 1+
2	Input Channel 0-	3	Input Channel 1-
4	Analog Ground	5	Analog Ground
6	Shield	7	Shield

Type B

temperature °C	0 °C	300 °C	900 °C	1800 °C
Data(Hex)	H 0000	H 0BB8	H 2328	H 4650

Thermocouple Input Range		
Type	Maximum Input Range	Recommended Input Range
Type K	-270 ~ 1372 °C	-100 ~ 1200 °C
Type J	-210 ~ 1200 °C	-100 ~ 1100 °C
Type T	-270 ~ 400 °C	-200 ~ 350 °C
Type B	30 ~ 1820 °C	500 ~ 1700 °C
Type R	-50 ~ 1768 °C	0 ~ 1600 °C
Type S	-50 ~ 1768 °C	0 ~ 1600 °C
Type E	-270 ~ 1000 °C	-200 ~ 800 °C
Type N	-270 ~ 1300 °C	-200 ~ 1250 °C
Type L	-200 ~ 900 °C	-100 ~ 850 °C
Type U	-200 ~ 600 °C	-100 ~ 550 °C
Type C	0 ~ 2310 °C	100 ~ 2100 °C
Type D	0 ~ 2490 °C	100 ~ 2200 °C

- °F = 1.8°C + 32

3.1.20. ST-3804

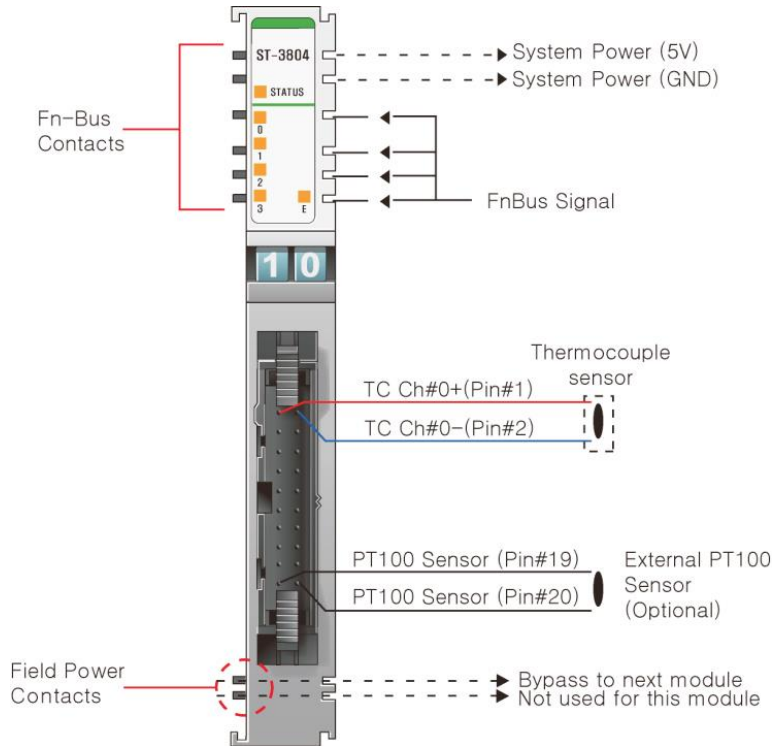

Pin No.	Description	Pin No.	Description
1	TC Ch#0+	2	TC Ch#0-
3	TC Ch#1+	4	TC Ch#1-
5	TC Ch#2+	6	TC Ch#2-
7	TC Ch#3+	8	TC Ch#3-
9	AGND	10	AGND
11	-	2	-
13	-	4	-
15	-	6	-
17	-	8	-
19	External PT100	20	External PT100

Type B

temperature °C	0 °C	300 °C	900 °C	1800 °C
Data(Hex)	H 0000	H 0BB8	H 2328	H 4650

LED : External PT100 Sensor status for Cold Junction Compensation (E)

Status	LED is	To indicate
Normal Operation	Off	External PT100 Sensor Not Found
Normal Operation	Green	External PT100 Sensor Found

3.1.21. ST-3808

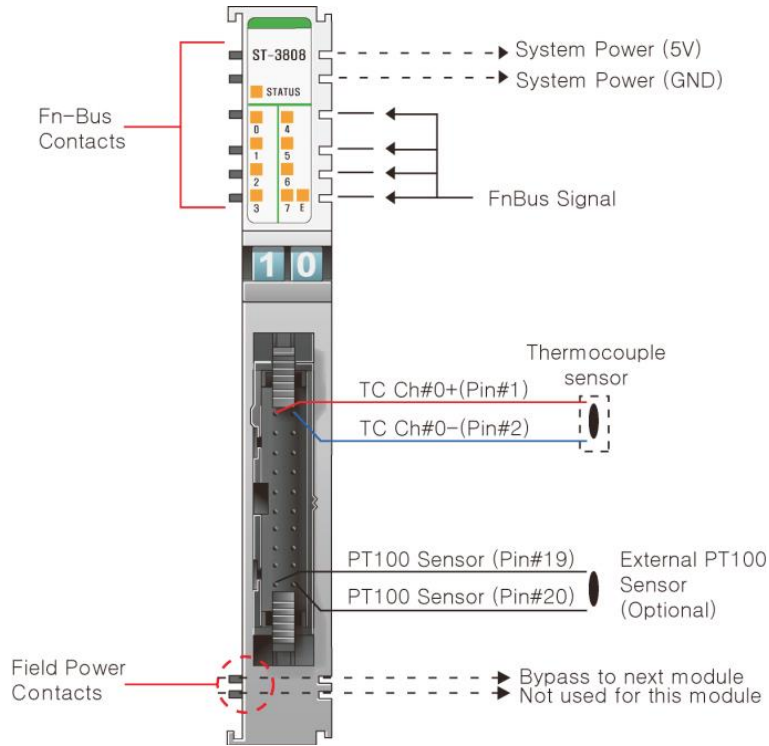

Pin No.	Description	Pin No.	Description
1	TC Ch#0+	2	TC Ch#0-
3	TC Ch#1+	4	TC Ch#1-
5	TC Ch#2+	6	TC Ch#2-
7	TC Ch#3+	8	TC Ch#3-
9	AGND	10	AGND
11	TC Ch#4+	2	TC Ch#4-
13	TC Ch#5+	4	TC Ch#5-
15	TC Ch#6+	6	TC Ch#6-
17	TC Ch#7+	8	TC Ch#7-
19	External PT100	20	External PT100

Type B

temperature °C	0 °C	300 °C	900 °C	1800 °C
Data(Hex)	H 0000	H 0BB8	H 2328	H 4650

LED : External PT100 Sensor status for Cold Junction Compensation (E)

Status	LED is	To indicate
Normal Operation	Off	External PT100 Sensor Not Found
Normal Operation	Green	External PT100 Sensor Found

3.2. Environment Specification

Environmental Specifications	
Operating Temperature	-20 to 55 °C (Discrete I/O) 0 to 55 °C (Analog I/O)
Non-Operating Temperature	-40 °C to 85 °C
Relative Humidity	5%~90% non-condensing
Operating Altitude	2000m
Mounting	DIN rail
General Specifications	
Shock Operating	10g
Shock Non-Operating	30g
Vibration/Shock resistance	Displacement : 0.012Inch p-p from 10~57Hz Acceleration : 2G's from 57~500Hz Sweep Rate : 1 octave Per Minute Axes to test : x, y, z Frequency Sweeps Per Axis : 10
EMC resistance burst/ESD	Confirms to EN-61000-6-2
EMI	Confirms to EN-61000-6-4
Installation Pos. /Protect. Class	Variable / IP20
Product Certification	UL / cUL, CE
Network Conformance	NA-9111 : ODVA Conformance Test Completion NA-9122 : PTO Conformance Test Completion NA-9131 : CLPA Conformance Test Completion
Isolation	DC Module (Included Analog Module) : Terminal Block to F.G 500Vac/1min AC Module : Terminal Block to F.G 1500Vac/1min Relay Module : Terminal Block to F.G 2500Vac/1min

3.3. Specification

3.3.1. ST-3114

Items	Specification
Input Specification	
Number of Inputs	4 Channels Single Ended, Non-isolated Between Channels
Indicators	4 Green/Red States, 1 Green/Red FnBus State
Resolution in Ranges	12Bits : 4.88uA/Bit
Input current Range	0 ~ 20mA
Data Format	16bits Integer (2's compliment)
Module Error	±0.1% Full Scale @25 °C ±0.3% Full Scale @0 °C, 60 °C
Input Impedance	120Ω
Conversion Time	4msec / All channel
Calibration	Not Required
Diagnostic	No
Common Type	4 Channels / 2COM (Single Common)
General Specification	
Power Supply	From System Power DC/DC
Power Dissipation	Max. 165mA @ 5.0Vdc
Isolation	I/O to Logic : Photocoupler isolation Field power : Not Connected
Wiring	I/O Cable Max. 2.0 mm ²
Weight	70g
Module Size	12mm x 99mm x 70mm
Environment Condition	Refer to " Environment Specification"(page : 35)

3.3.2. ST-3118

Items	Specification
Input Specification	
Number of Inputs	8 Channels Single Ended
Indicators	1 Green/Red FnBus State
Resolution in Ranges	12Bits : 4.88uA/Bit
Input current Range	0 ~ 20mA
Data Format	16bits Integer (2's compliment)
Module Error	±0.1% Full Scale @25 °C ±0.3% Full Scale @0 °C, 60 °C
Input Impedance	120Ω
Conversion Time	4msec / All channel
Calibration	Not Required
Diagnostic	No
Common Type	Nothing in the module terminal Field Power 0V is Common(AGND)
General Specification	
Power Dissipation	Max. 80mA @ 5.0Vdc
Isolation	I/O to Logic : Photocoupler isolation I/O to Logic : Non-Isolation
Field Power	Supply Voltage : 24Vdc nominal Voltage Range : 18~28.8Vdc Power Dissipation: Max. 40mA@24Vdc
Wiring	I/O Cable Max. 2.0 mm ²
Weight	70g
Module Size	12mm x 99mm x 70mm
Environment Condition	Refer to " Environment Specification"(page : 35)

3.3.3. ST-3134

Items	Specification
Input Specification	
Number of Inputs	4 Channels Single Ended, Non-isolated Between Channels
Indicators	4 Green/Red States, 1 Green/Red FnBus State
Resolution in Ranges	14Bits : 1.22uA/Bit
Input current Range	0 ~ 20mA
Data Format	16bits Integer (2's compliment)
Module Error	±0.1% Full Scale @25 °C ±0.3% Full Scale @0 °C, 60 °C
Input Impedance	120Ω
Conversion Time	4msec / All channel
Calibration	Not Required
Diagnostic	No
Common Type	4 Channels / 2COM (Single Common)
General Specification	
Power Supply	From System Power DC/DC
Power Dissipation	Max. 165mA @ 5.0Vdc
Isolation	I/O to Logic : Photocoupler isolation Field power : Not Connected
Wiring	I/O Cable Max. 2.0 mm ²
Weight	70g
Module Size	12mm x 99mm x 70mm
Environment Condition	Refer to " Environment Specification"(page : 35)

3.3.4. ST-3214

Items	Specification
Input Specification	
Number of Inputs	4 Channels Single Ended, Non-isolated Between Channels
Indicators	4 Green/Red States, 1 Green/Red FnBus State
Resolution in Ranges	12Bits : 3.9uA/Bit
Input current Range	4 ~ 20mA
Data Format	16bits Integer (2's compliment)
Module Error	±0.1% Full Scale @25 °C ±0.3% Full Scale @0 °C, 60 °C
Input Impedance	120Ω
Conversion Time	4msec / All channel
Calibration	Not Required
Diagnostic	Channel Open (if < 3mA, Data=0x8000)
Common Type	4 Channels / 2COM (Single Common)
General Specification	
Power Supply	From System Power DC/DC
Power Dissipation	Max. 165mA @ 5.0Vdc
Isolation	I/O to Logic : Photocoupler isolation Field power : Not Connected
Wiring	I/O Cable Max. 2.0 mm ²
Weight	70g
Module Size	12mm x 99mm x 70mm
Environment Condition	Refer to " Environment Specification"(page : 35)

3.3.5. ST-3218

Items	Specification
Input Specification	
Number of Inputs	8 Channels Single Ended
Indicators	1 Green/Red FnBus State
Resolution in Ranges	12Bits : 3.9uA/Bit
Input current Range	4 ~ 20mA
Data Format	16bits Integer (2's compliment)
Module Error	±0.1% Full Scale @25 °C ±0.3% Full Scale @0 °C, 60 °C
Input Impedance	120Ω
Conversion Time	4msec / All channel
Calibration	Not Required
Diagnostic	No
Common Type	Nothing in the module terminal Field Power 0V is Common(AGND)
General Specification	
Power Dissipation	Max. 80mA @ 5.0Vdc
Isolation	I/O to Logic : Photocoupler isolation I/O to Logic : Non-Isolation
Field Power	Supply Voltage : 24Vdc nominal Voltage Range : 18~28.8Vdc Power Dissipation: Max. 40mA@24Vdc
Wiring	I/O Cable Max. 2.0 mm ²
Weight	70g
Module Size	12mm x 99mm x 70mm
Environment Condition	Refer to " Environment Specification"(page : 35)

3.3.6. ST-3234

Items	Specification
Input Specification	
Number of Inputs	4 Channels Single Ended, Non-isolated Between Channels
Indicators	4 Green/Red States, 1 Green/Red FnBus State
Resolution in Ranges	14Bits : 0.9uA/Bit
Input current Range	4 ~ 20mA
Data Format	16bits Integer (2's compliment)
Module Error	±0.1% Full Scale @25 °C ±0.3% Full Scale @0 °C, 60 °C
Input Impedance	120Ω
Conversion Time	4msec / All channel
Calibration	Not Required
Diagnostic	Channel Open (if < 3mA, Data=0x8000)
Common Type	4 Channels / 2COM (Single Common)
General Specification	
Power Supply	From System Power DC/DC
Power Dissipation	Max. 165mA @ 5.0Vdc
Isolation	I/O to Logic : Photocoupler isolation Field power : Not Connected
Wiring	I/O Cable Max. 2.0 mm ²
Weight	70g
Module Size	12mm x 99mm x 70mm
Environment Condition	Refer to " Environment Specification"(page : 35)

3.3.7. ST-3274

Items	Specification
Input Specification	
Number of Inputs	4 Channels Single Ended
Indicators	1 Green/Red FnBus State
Resolution in Ranges	12Bits : 3.9uA/Bit
Input current Range	4 ~ 20mA
Data Format	16bits Integer (2's compliment)
Module Error	±0.1% Full Scale @25 °C ±0.3% Full Scale @0 °C, 60 °C
Input Impedance	120Ω
Conversion Time	4msec / All channel
Calibration	Not Required
Diagnostic	No
Common Type	Nothing in the module terminal Field Power 0V is Common(AGND)
General Specification	
Power Dissipation	Max. 40mA @ 5.0Vdc, TBD
Isolation	I/O to Logic : Photocoupler isolation Field power : Not Isolation
Field Power	Supply Voltage : 24Vdc nominal Voltage Range : 20~26Vdc Power Dissipation : Max.20mA@24Vdc, TBD
Wiring	3M Mini-Clamp Socket 4pin, 37204-62A3-004PL Matching Connector : 3M Mini-Clamp Plug, 37104 Series AWG#20~22 available
Weight	70g
Module Size	12mm x 99mm x 70mm
Environment Condition	Refer to " Environment Specification"(page : 35)

3.3.8. ST-3424

Items	Specification
Input Specification	
Number of Inputs	4 Channels Single Ended, Non-isolated Between Channels
Indicators	4 Green/Red States, 1 Green/Red FnBus State
Resolution in Ranges	12Bits : 2.44mV/Bit
Input current Range	0~10Vdc
Data Format	16bits Integer (2's compliment)
Module Error	±0.1% Full Scale @25 °C ±0.3% Full Scale @0 °C, 60 °C
Input Impedance	500KΩ
Conversion Time	4msec / All channel
Calibration	Not Required
Diagnostic	No
Common Type	4 Channels / 2COM (Single Common)
General Specification	
Power Supply	From System Power DC/DC
Power Dissipation	Max. 165mA @ 5.0Vdc
Isolation	I/O to Logic : Photocoupler isolation Field power : Not Connected
Wiring	I/O Cable Max. 2.0 mm ²
Weight	70g
Module Size	12mm x 99mm x 70mm
Environment Condition	Refer to " Environment Specification"(page : 35)

3.3.9. ST-3428

Items	Specification
Input Specification	
Number of Inputs	8 Channels Single Ended
Indicators	1 Green/Red FnBus State
Resolution in Ranges	12Bits : 2.44mV/Bit
Input current Range	0~10Vdc
Data Format	16bits Integer (2's compliment)
Module Error	±0.1% Full Scale @25 °C ±0.3% Full Scale @0 °C, 60 °C
Input Impedance	500KΩ
Conversion Time	4msec / All channel
Calibration	Not Required
Diagnostic	No
Common Type	Nothing in the module terminal Field Power 0V is Common(AGND)
General Specification	
Power Dissipation	Max. 80mA @ 5.0Vdc
Isolation	I/O to Logic : Photocoupler isolation Field power : Non-Isolation
Field Power	Supply Voltage : 24Vdc nominal Voltage Range : 18~28.8Vdc Power Dissipation: Max. 40mA@24Vdc
Wiring	I/O Cable Max. 2.0 mm ²
Weight	70g
Module Size	12mm x 99mm x 70mm
Environment Condition	Refer to " Environment Specification"(page : 35)

3.3.10. ST-3444

Items	Specification
Input Specification	
Number of Inputs	4 Channels Single Ended, Non-isolated Between Channels
Indicators	4 Green/Red States, 1 Green/Red FnBus State
Resolution in Ranges	14Bits : 0.6mV/Bit
Input current Range	0~10Vdc
Data Format	16bits Integer (2's compliment)
Module Error	±0.1% Full Scale @25 °C ±0.3% Full Scale @0 °C, 60 °C
Input Impedance	500KΩ
Conversion Time	4msec / All channel
Calibration	Not Required
Diagnostic	No
Common Type	4 Channels / 2COM (Single Common)
General Specification	
Power Supply	From System Power DC/DC
Power Dissipation	Max. 170mA @ 5.0Vdc
Isolation	I/O to Logic : Photocoupler isolation Field power : Not Connected
Wiring	I/O Cable Max. 2.0 mm ²
Weight	70g
Module Size	12mm x 99mm x 70mm
Environment Condition	Refer to " Environment Specification"(page : 35)

3.3.11. ST-3474

Items	Specification
Input Specification	
Number of Inputs	4 Channels Single Ended
Indicators	1 Green/Red FnBus State
Resolution in Ranges	12Bits : 2.44mV/Bit
Input current Range	0 ~ 10Vdc
Data Format	16bits Integer (2's compliment)
Module Error	±0.1% Full Scale @25 °C ±0.3% Full Scale @0 °C, 60 °C
Input Impedance	500KΩ
Conversion Time	4msec / All channel
Calibration	Not Required
Diagnostic	No
Common Type	Nothing in the module terminal Field Power 0V is Common(AGND)
General Specification	
Power Dissipation	Max. 80mA @ 5.0Vdc, TBD
Isolation	I/O to Logic : Photocoupler isolation Field power : Not Isolation
Field Power	Supply Voltage : 24Vdc nominal Voltage Range : 20~26Vdc Power Dissipation : Max.20mA@24Vdc, TBD
Wiring	3M Mini-Clamp Socket 4pin, 37204-62A3-004PL Matching Connector : 3M Mini-Clamp Plug, 37104 Series AWG#20~22 available
Weight	70g
Module Size	12mm x 99mm x 70mm
Environment Condition	Refer to " Environment Specification"(page : 35)

3.3.12. ST-3524

Items	Specification
Input Specification	
Number of Inputs	4 Channels Single Ended, Non-isolated Between Channels
Indicators	4 Green/Red States, 1 Green/Red FnBus State
Resolution in Ranges	12Bits : 4.8mV/Bit
Input current Range	-10~10Vdc
Data Format	16bits Integer (2's compliment)
Module Error	±0.1% Full Scale @25 °C ±0.3% Full Scale @0 °C, 60 °C
Input Impedance	500KΩ
Conversion Time	4msec / All channel
Calibration	Not Required
Diagnostic	No
Common Type	4 Channels / 2COM (Single Common)
General Specification	
Power Supply	From System Power DC/DC
Power Dissipation	Max. 170mA @ 5.0Vdc
Isolation	I/O to Logic : Photocoupler isolation Field power : Not Connected
Wiring	I/O Cable Max. 2.0 mm ²
Weight	70g
Module Size	12mm x 99mm x 70mm
Environment Condition	Refer to " Environment Specification"(page : 35)

3.3.13. ST-3544

Items	Specification
Input Specification	
Number of Inputs	4 Channels Single Ended, Non-isolated Between Channels
Indicators	4 Green/Red States, 1 Green/Red FnBus State
Resolution in Ranges	14Bits : 1.2mV/Bit
Input current Range	-10~10Vdc
Data Format	16bits Integer (2's compliment)
Module Error	±0.1% Full Scale @25 °C ±0.3% Full Scale @0 °C, 60 °C
Input Impedance	500KΩ
Conversion Time	4msec / All channel
Calibration	Not Required
Diagnostic	No
Common Type	4 Channels / 2COM (Single Common)
General Specification	
Power Supply	From System Power DC/DC
Power Dissipation	Max. 200mA @ 5.0Vdc
Isolation	I/O to Logic : Photocoupler isolation Field power : Not Connected
Wiring	I/O Cable Max. 2.0 mm ²
Weight	70g
Module Size	12mm x 99mm x 70mm
Environment Condition	Refer to " Environment Specification"(page : 35)

3.3.14. ST-3624

Items	Specification
Input Specification	
Number of Inputs	4 Channels Single Ended, Non-isolated Between Channels
Indicators	4 Green/Red States, 1 Green/Red FnBus State
Resolution in Ranges	12Bits : 1.22mV/Bit
Input current Range	0~5Vdc
Data Format	16bits Integer (2's compliment)
Module Error	±0.1% Full Scale @25 °C ±0.3% Full Scale @0 °C, 60 °C
Input Impedance	500KΩ
Conversion Time	4msec / All channel
Calibration	Not Required
Diagnostic	No
Common Type	4 Channels / 2COM (Single Common)
General Specification	
Power Supply	From System Power DC/DC
Power Dissipation	Max. 170mA @ 5.0Vdc
Isolation	I/O to Logic : Photocoupler isolation Field power : Not Connected
Wiring	I/O Cable Max. 2.0 mm ²
Weight	70g
Module Size	12mm x 99mm x 70mm
Environment Condition	Refer to " Environment Specification"(page : 35)

3.3.15. ST-3644

Items	Specification
Input Specification	
Number of Inputs	4 Channels Single Ended, Non-isolated Between Channels
Indicators	4 Green/Red States, 1 Green/Red FnBus State
Resolution in Ranges	14Bits : 0.3mV/Bit
Input current Range	0~5Vdc
Data Format	16bits Integer (2's compliment)
Module Error	±0.1% Full Scale @25 °C ±0.3% Full Scale @0 °C, 60 °C
Input Impedance	500KΩ
Conversion Time	4msec / All channel
Calibration	Not Required
Diagnostic	No
Common Type	4 Channels / 2COM (Single Common)
General Specification	
Power Supply	From System Power DC/DC
Power Dissipation	Max. 200mA @ 5.0Vdc
Isolation	I/O to Logic : Photocoupler isolation Field power : Not Connected
Wiring	I/O Cable Max. 2.0 mm ²
Weight	70g
Module Size	12mm x 99mm x 70mm
Environment Condition	Refer to " Environment Specification"(page : 35)

3.3.16. ST-3702

Items	Specification
Input Specification	
Number of Inputs	2 Channels Single Ended, Non-isolated Between Channels
Indicators	2 Green/Red States, 1 Green/Red FnBus State
Sensor Types	PT50, PT100, PT200, PT500, PT1000, JPT100, JPT200, JPT500, JPT1000, NI100, NI200, NI500, NI1000, NI120, CU10, Resistance 100mΩ/Bit, Resistance 10mΩ/Bit, Resistance 20mΩ/Bit
Conversion Time	200msec / All Channel
Data Format	16bits Integer (2's compliment)
Dissolution ability	0.1 °C / 10mΩ
Module Error	±0.1% Full Scale @25 °C ±0.3% Full Scale @0 °C, 60 °C
Calibration	Not Required
Diagnostic	Channel Open (if it is not Connected, Data=0x8000)
Common Type	2 Channels / 2COM (Single Common)
General Specification	
Power Supply	From System Power DC/DC
Power Dissipation	Max. 70mA @ 5.0Vdc
Isolation	I/O to Logic : Photocoupler isolation Field power : Not Connected
Wiring	I/O Cable Max. 2.0 mm ²
Weight	70g
Module Size	12mm x 99mm x 70mm
Environment Condition	Refer to " Environment Specification"(page : 35)

3.3.17. ST-3704

Items	Specification
Input Specification	
Number of Inputs	4 Channels
Indicators	1 Green/Red Status, 4 Green States
Sensor Types	RTD Input - PT 100, PT200, PT500, PT1000, PT50 - JPT100, JPT200, JPT500, JPT1000, JPT50 - NI100, NI200, NI500, NI000 - NI120, NI1000LG Resistance Input - 100mΩ/bit, 10mΩ/bit, 20mΩ/bit, 50mΩ/bit
Excitation Current	About 1mA
Conversion Method	3-Wire or 2-Wire
Conversion Time	30msec/1Channel when Normal Conversion
Data Format	16bits signed Integer(2's compliment)
Resolution of Data	±0.1 °C/ F, 10mΩ
Module Accuracy	±0.1% Full Scale @25 °C ±0.3% Full Scale @0 °C, 60 °C
Calibration	Not Required
Diagnostic	Sensor Open or Range Over, then Conversion Data=0x8000(-32768) Except Resistance Input Mode
Common Type	4 Common/Module
General Specification	
Power Dissipation	Max. 100mA @5.0Vdc
Isolation	I/O to Control Logic : Photocoupler Isolation
Field power	Not used, Field Power by pass to next expansion module
Wiring	Connector Type, up to AWG22 Module Connector : HIF3BA-20D-2.54DSA
Weight	70g
Module Size	12mm x 99mm x 70mm
Environment Condition	Refer to " Environment Specification"(page : 35)

3.3.18. ST-3708

Items	Specification
Input Specification	
Number of Inputs	8 Channels
Indicators	1 Green/Red LED, Module Status, 8Green LED, Input State
Sensor Types	RTD Input - PT 100, PT200, PT500, PT1000, PT50 - JPT100, JPT200, JPT500, JPT1000, JPT50 - NI100, NI200, NI500, NI000 - NI120, NI1000LG Resistance Input - 100mΩ/bit, 10mΩ/bit, 20mΩ/bit, 50mΩ/bit
Excitation Current	About 1mA
Conversion Method	3-Wire or 2-Wire
Conversion Time	30msec/1Channel when Normal Conversion
Data Format	16bits signed Integer(2's compliment)
Resolution of Data	±0.1 °C/ F, 10mΩ
Module Accuracy	±0.1% Full Scale @25 °C ±0.3% Full Scale @0 °C, 60 °C
Calibration	Not Required
Diagnostic	Sensor Open or Range Over, then Conversion Data=0x8000(-32768) Except Resistance Input Mode
Common Type	4 Common/Module
General Specification	
Power Dissipation	Max. 110mA @5.0Vdc
Isolation	I/O to Control Logic : Photocoupler Isolation
Field power	Not used, Field Power by pass to next expansion module
Wiring	Connector Type, up to AWG22 Module Connector : HIF3BA-20D-2.54DSA
Weight	70g
Module Size	12mm x 99mm x 70mm
Environment Condition	Refer to " Environment Specification"(page : 35)

3.3.19. ST-3802

Items	Specification
Input Specification	
Number of Inputs	2 Channels Single Ended, Non-isolated Between Channels
Indicators	2 Green/Red States, 1 Green/Red FnBus State
Sensor Types	Type K/J/T/B/R/S/E/N/L/U/C/D mV Input 10uV/Bit, 1uV/Bit, 2uV/Bit
Conversion Time	200msec / All Channel
Data Format	16bits Integer (2's compliment)
Dissolution ability	0.1 °C / 10mΩ
Module Error	±0.1% Full Scale @25 °C ±0.3% Full Scale @0 °C, 60 °C
Calibration	Not Required
Diagnostic	Channel Open (if it is not Connected, Data=0x8000)
Common Type	2 Channels / 2COM (Single Common)
General Specification	
Power Supply	From System Power DC/DC
Power Dissipation	Max. 70mA @ 5.0Vdc
Isolation	I/O to Logic : Photocoupler isolation Field power : Not Connected
Connection	2 or 3-Wire
Wiring	I/O Cable Max. 2.0 mm ²
Weight	70g
Module Size	12mm x 99mm x 70mm
Environment Condition	Refer to " Environment Specification"(page : 35)

3.3.20. ST-3804

Items	Specification
Input Specification	
Number of Inputs	4 Channels
Indicators	1 Green/Red LED, Module Status 4 Green LED, Input State 1 Green LED, E, Cold Junction
Sensor Types	Thermocouple Input - Type K/J/T/B/R/S/E/N/L/U/C/D mV Input -10uV/bit, 1uV/bit, 2uV/bit
Cold Junction Temperature	-20~70℃
Cold Junction Compensation Method	External "PT100 Sensor (recommended) or Internal Temperature Sensor *Auto Detection if External PT100 (high priority) is Connected
Conversion Time	30msec/1Channel when Normal Conversion
Data Format	16bits Integer (2's compliment)
Resolution of Data	±0.1℃/ F, 10mΩ
Module Accuracy	±0.1% Full Scale @25℃ (K/J/mV) ±0.3% Full Scale @0℃, 60℃(K/J/mV) ±0.5% Full Scale @25℃ (The others) ±1.0% Full Scale @0℃, 60℃(The others)
Calibration	Not Required
Diagnostic	Sensor Open or Range Over, then Conversion Data=0x8000(-32768)
Common Type	1 Common / 1 Input
General Specification	
System Power Dissipation	Max. 120mA @ 5.0Vdc
Isolation	I/O to Control Logic : Photocoupler Isolation
Field Power	Not used, Field Power by pass to next expansion module
Wiring	Connector Type, up to AWG22 Module Connector : HIF3BA-20D-2.54DSA
Weight	70g
Module Size	12mm x 99mm x 70mm
Environment Condition	Refer to " Environment Specification"(page : 35)

- For more Accuracy, strongly recommend to use Extern PT100 Sensor for Cold Junction Compensation.
- If External PT100 Sensor is found, ST-3804/3808 uses PT100 Temperature as Cold Junction Compensation.

3.3.21. ST-3808

Items	Specification
Input Specification	
Number of Inputs	8 Channels
Indicators	1 Green/Red LED, Module Status 8 Green LED, Input State 1 Green LED, E, Cold Junction
Sensor Types	Thermocouple Input - Type K/J/T/B/R/S/E/N/L/U/C/D mV Input - 10uV/bit, 1uV/bit, 2uV/bit
Cold Junction Temperature	-20~70°C
Cold Junction Compensation Method	External "PT100 Sensor (recommended) or Internal Temperature Sensor *Auto Detection if External PT100 (high priority) is Connected
Conversion Time	30msec/1Channel when Normal Conversion
Data Format	16bits Integer (2's compliment)
Resolution of Data	±0.1 °C / F, 10mΩ
Module Accuracy	±0.1% Full Scale @25 °C (K/J/mV) ±0.3% Full Scale @0 °C, 60 °C(K/J/mV) ±0.5% Full Scale @25 °C (The others) ±1.0% Full Scale @0 °C, 60 °C(The others)
Calibration	Not Required
Diagnostic	Sensor Open or Range Over, then Conversion Data=0x8000(-32768)
Common Type	1 Common / 1 Input
General Specification	
System Power Dissipation	Max. 140mA @ 5.0Vdc
Isolation	I/O to Control Logic : Photocoupler Isolation
Field Power	Not used, Field Power by pass to next expansion module
Wiring	Connector Type, up to AWG22 Module Connector : HIF3BA-20D-2.54DSA
Weight	70g
Module Size	12mm x 99mm x 70mm
Environment Condition	Refer to " Environment Specification"(page : 35)

- For more Accuracy, strongly recommend to use Extern PT100 Sensor for Cold Junction Compensation.
- If External PT100 Sensor is found, ST-3804/3808 uses PT100 Temperature as Cold Junction Compensation.

4. Dimension

4.1. ST-3xx2, ST-3xx4, ST-3xx8

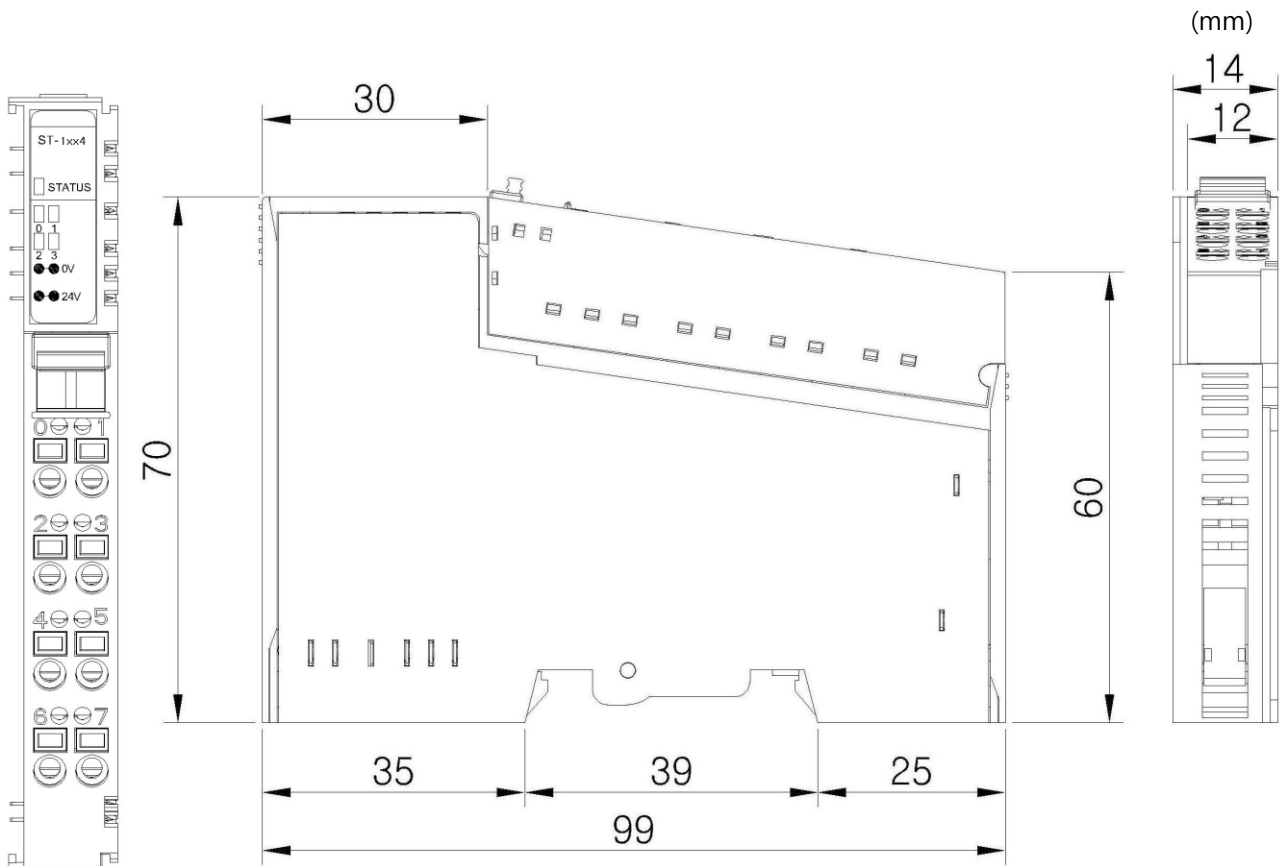

4.2. ST-3704, ST-3708, ST-3804, ST-3808

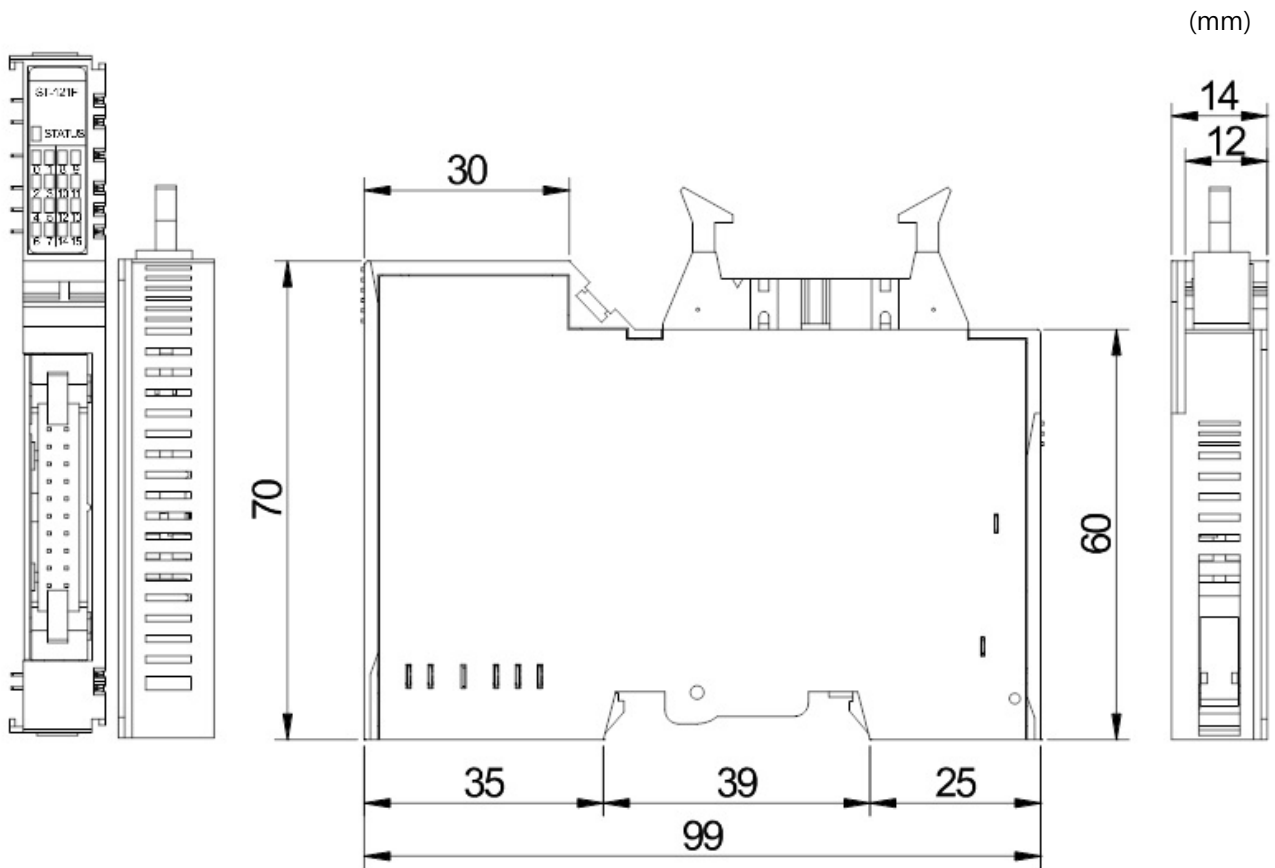

4.3. ST-3274, ST-3474

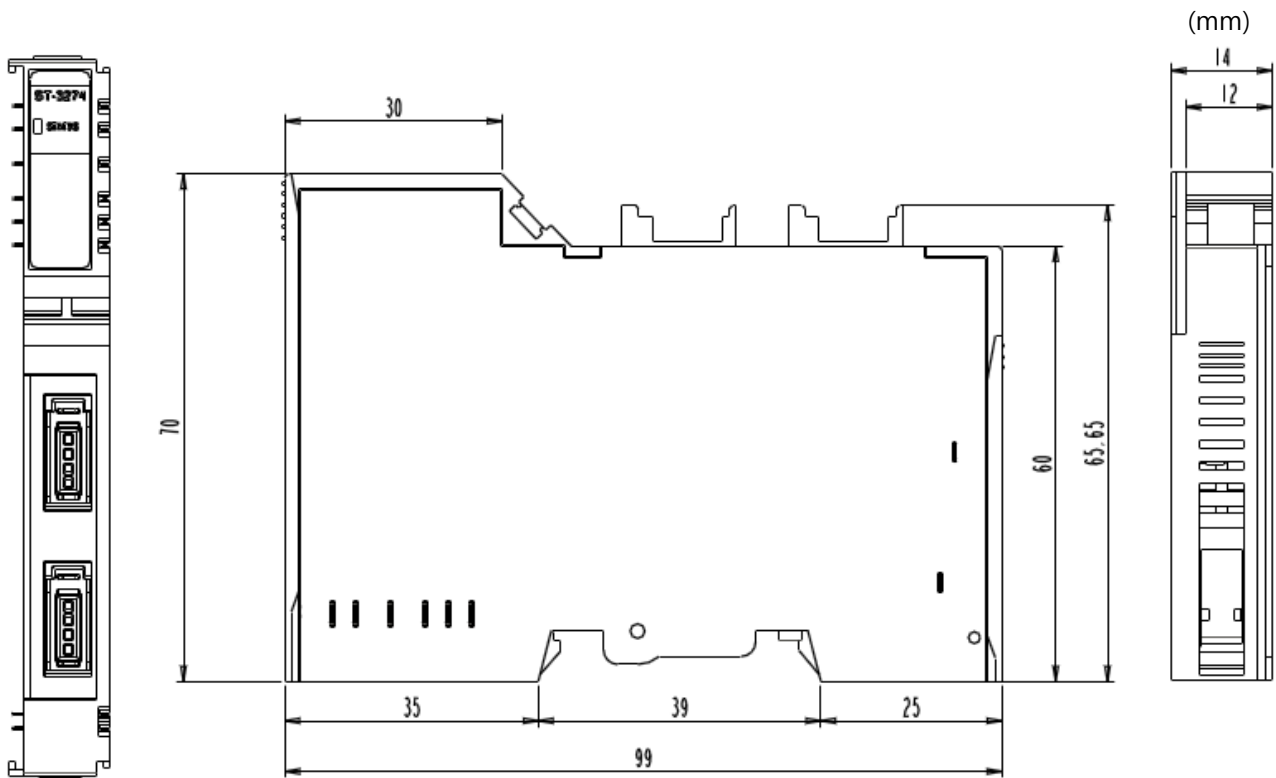

5. Mapping Data into the image Table

5.1. ST-3xx2

Input Module Data

Analog Input Ch 0
Analog Input Ch 1



Input Image Value

Bit No	Bit7	Bit6	Bit5	Bit4	Bit3	Bit2	Bit1	Bit0
Byte 0	Analog Input Ch 0 Low byte							
Byte 1	Analog Input Ch 0 High byte							
Byte 2	Analog Input Ch 1 Low byte							
Byte 3	Analog Input Ch 1 High byte							

5.2. ST-3xx4

Input Module Data

Analog Input Ch 0
Analog Input Ch 1
Analog Input Ch 2
Analog Input Ch 3



Input Image Value

Bit No	Bit7	Bit6	Bit5	Bit4	Bit3	Bit2	Bit1	Bit0
Byte 0	Analog Input Ch 0 Low byte							
Byte 1	Analog Input Ch 0 High byte							
Byte 2	Analog Input Ch 1 Low byte							
Byte 3	Analog Input Ch 1 High byte							
Byte 4	Analog Input Ch 2 Low byte							
Byte 5	Analog Input Ch 2 High byte							
Byte 6	Analog Input Ch 3 Low byte							
Byte 7	Analog Input Ch 3 High byte							

5.3. ST-3xx8

Input Module Data
- 16byte Input Data

Analog Input Ch 0
Analog Input Ch 1
Analog Input Ch 2
Analog Input Ch 3
Analog Input Ch 4
Analog Input Ch 5
Analog Input Ch 6
Analog Input Ch 7



Input Image Value

Bit No	Bit7	Bit6	Bit5	Bit4	Bit3	Bit2	Bit1	Bit0
Byte 0	Analog Input Ch 0 Low byte							
Byte 1	Analog Input Ch 0 High byte							
Byte 2	Analog Input Ch 1 Low byte							
Byte 3	Analog Input Ch 1 High byte							
Byte 4	Analog Input Ch 2 Low byte							
Byte 5	Analog Input Ch 2 High byte							
Byte 6	Analog Input Ch 3 Low byte							
Byte 7	Analog Input Ch 3 High byte							
Byte 8	Analog Input Ch4 Low byte							
Byte 9	Analog Input Ch4 High byte							
Byte 10	Analog Input Ch5 Low byte							
Byte 11	Analog Input Ch5 High byte							
Byte 12	Analog Input Ch6 Low byte							
Byte 13	Analog Input Ch6 High byte							
Byte 14	Analog Input Ch7 Low byte							
Byte 15	Analog Input Ch7 High byte							

5.4. ST-3274, ST-3474

IO Input Image Data

- 8 byte

Bit No	Bit7	Bit6	Bit5	Bit4	Bit3	Bit2	Bit1	Bit0
Byte 0	Ch#0 Conversion Data Low byte							
Byte 1	Ch#0 Conversion Data High byte							
Byte 2	Ch#1 Conversion Data Low byte							
Byte 3	Ch#1 Conversion Data High byte							
Byte 4	Ch#2 Conversion Data Low byte							
Byte 5	Ch#2 Conversion Data High byte							
Byte 6	Ch#3 Conversion Data Low byte							
Byte 7	Ch#3 Conversion Data High byte							

Configuration Parameter Data-4byte

Byte	Bit7	Bit6	Bit5	Bit4	Bit3	Bit2	Bit1	Bit0
	Ch#3 Fault Action		Ch#2 Fault Action		Ch#1 Fault Action		Ch#0 Fault Action	
0	Fault Action 00b : Fault Value (* All Channels use the same fault value) 01b : Hold Last Value 10b : Low Limit 11b : High Limit							
1	Reserved							
2	Ch#0~3 Fault Value Low							
3	Ch#0~3 Fault Value High							

6. Trouble Shooting

ATTENTION



In this manual, it couldn't be described all variety case with Network Adapter of several protocols. So if you couldn't find any fault after investigating all below cases, refer to NA user manual.

6.1. Normal Module

LED Status	Cause	Action
EXPANSION MODULE STATUS LED	Off	Not Power No Initialized
	Green	Fn-Bus Connection
	Flashing Green	Fn-Bus Ready
	Flashing Red	Fn-Bus Fault
	Red	Device Fault
CHANNEL STATUS LED	Off	Device has no expansion Module or may not be powered The Parameter is not initialized yet.
	Green	FnBus normal Operation
		FnBus ready
		FnBus Time Out, FnBus Failed Communication
		Device fault
	Not Signal	Normal Operation
	On Signal	Normal Operation

6.2. ST-3704, ST-3708, ST-3804, ST-3808

LED Status	Cause	Action
EXPANSION MODULE STATUS LED		
Off	Not Power No Initialized	Not powered Not Initialized yet.
Green	Module Connection	Normal Operation, IO Exchange
Flashing Green	Module Ready	Module ready
Flashing Red	Module Fault	Module failed in Communication
Red	Module Fault	Module fault
CHANNEL STATUS LED		
Off	Normal Operation	Input Sensor Open or Input Range Over
Green	Normal Operation	Sensor Connected and Input Range Valid
Red	Channel Fault	Channel Open