

**1000Base-X to 10/100/1000Base-T  
802.3at PoE Media Converter**

User's Manual

## **Trademarks**

Copyright © Antaira Technologies 2013.

Contents subject to revision without prior notice.

Antaira is a registered trademark of Antaira Technologies. The information in this manual is subject to change without notice. All other trademarks belong to their respective owners.

## **Disclaimer**

Antaira Technologies does not warrant that the hardware will work properly in all environments and/or applications, and makes no warranty and representation, either implied or expressed, with respect to the quality, performance, merchantability, or fitness for a particular purpose.

Antaira has made every effort to ensure that this User's Manual is accurate; Antaira disclaims liability for any inaccuracies or omissions that may have occurred.

Information in this User's Manual is subject to change without notice and does not represent a commitment on the part of Antaira. Antaira assumes no responsibility for any inaccuracies that may be contained in this User's Manual. Antaira makes no commitment to update or keep current the information in this User's Manual, and reserves the right to make improvements to this User's Manual and/or to the products described in this User's Manual, at any time without notice.

If you find information in this manual that is incorrect, misleading, or incomplete, we would appreciate your comments and suggestions.

## **FCC Warning**

This equipment has been tested and found to comply with the regulations for a Class A digital device, pursuant to Part 15 of the FCC Rules. These limits are designed to provide reasonable protection against harmful interference when the equipment is operated in a commercial environment. This equipment generates, uses, and can radiate radio frequency energy and, if not installed and used in accordance with this user's guide, may cause harmful interference to radio communications. Operation of this equipment in a residential area is likely to cause harmful interference, in which case the user will be required to correct the interference at his own expense.

## **CE Mark Warning**

This is a Class A product. In a domestic environment, this product may cause radio interference, in which case the user may be required to take adequate measures.

## **Energy Saving Note of the Device**

This power required device does not support Standby mode operation.

For energy saving, please remove the DC-plug to disconnect the device from the power circuit.

Without removing the DC-plug, the device will still consume power from the power source. In the view of Saving the Energy and reduce the unnecessary power consuming, it is strongly suggested to remove the DC-plug for the device if this device is not intended to be active.

## WEEE Warning



To avoid the potential effects on the environment and human health as a result of the presence of hazardous substances in electrical and electronic equipment, end users of electrical and electronic equipment should understand the meaning of the crossed-out wheeled bin symbol. Do not dispose of WEEE as unsorted municipal waste and have to collect such WEEE separately.

## Revision

Antaira 1000Base-X to 10/100/1000Base-T 802.3at PoE+ Media Converter User's Manual

**Rev 1.2** January, 2013

**Part No.** 2350-AA4480-471

# Table of Contents

|  |    |
|--|----|
| 1. Overview .....                                  | 6  |
| About the Power over Ethernet Injector .....       | 6  |
| 2. Checklist .....                                 | 7  |
| 3. Product Outlook.....                            | 8  |
| 4. Link Fault Pass Through (LFP).....              | 10 |
| Link Loss Carry Forward (LLCF) .....               | 10 |
| Link Loss Return (LLR).....                        | 11 |
| 5. Installing the Converter.....                   | 13 |
| 6. PoE Function .....                              | 15 |
| 7. LED Indication.....                             | 17 |
| 8. Cable Connection Parameter .....                | 18 |
| 9. FCU-2805P-SFP Technical Specifications .....    | 19 |
| APPENDIX A.....                                    | 20 |
| A.1 Device's RJ-45 Pin Assignments .....           | 20 |
| A.2 RJ-45 Cable Pin Assignment .....               | 21 |
| A.3 Fiber Optical Cable Connection Parameter ..... | 22 |

## **1. Overview**

Thank you for purchasing the Antaira 1000Base-X Fiber-optic to 10/100/1000Mbps Ethernet Twisted pair 802.3at PoE Bridge Converter. This converter is used to convert one type to another equivalent type of media signal that allows the two segments to connect easily, efficiently and inexpensively. The converter provides a Power over Ethernet power injector function which is able to drive IEEE 802.3at / 802.3af compliant powered devices.

### **About the Power over Ethernet Injector**

The FCU-2805P-SFP is an IEEE 802.3at / 802.3af Power over Ethernet Injector that provides DC 52V over Ethernet cables. By inserting DC Voltage into Cat.5 / 5e/ 6 cables, the cable between the Injector (FCU-2805P-SFP) and PoE PD (Powered Device) allows the transfer of data and power simultaneously. The maximum distance between the Injector and PoE PD is 100 meters. The FCU-2805P-SFP combines Ethernet digital data with power over the twisted pair cables as an IEEE 802.3at / 802.3af Power over Ethernet Injector. Using the Power over Ethernet splitter, it can separate the digital data and the power into two outputs.

The benefits of the Antaira FCU-2805P-SFP include ease of network planning, higher reliability, and cost effectiveness. When any IEEE 802.3at / 802.3af device is installed, the FCU-2805P-SFP or PD can make a connection while migrating and the Ethernet digital packets, such as connecting the FCU-2805P-SFP to an IEEE 802.3at / 802.3af complied devices, wireless AP or IP Camera.

---

## 2. Checklist

Your FCU-2805P-SFP box should contain the following items:

1. 1000Base-X to 10/100/1000Base-T 802.3at PoE Media Converter x 1
2. User's Manual x 1
3. AC-DC Adapter (Input: 52V~56V DC, 0.58A max.) x 1
4. Power Cord x 1

If any of these are missing or damaged, please contact your dealer immediately. If possible, retain the carton including the original packing material, and use them to repack the product in case there is a need to return it to us for repair.



Note

FCU-2805P-SFP has one vacant SFP module slot. The mini GBIC SFP module is not bundled within the package.

### 3. Product Outlook

#### Overview

The layout of the FCU-2805P-SFP

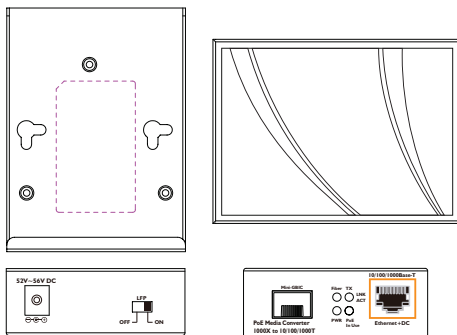

**Figure 3-1:** Product Outlook of the FCU-2805P-SFP



## Left View

There is one RJ-45 Twisted-Pair jack (Auto-MDI/MDI-X), one fiber-optic connector (vary by model) and four LED indicators.

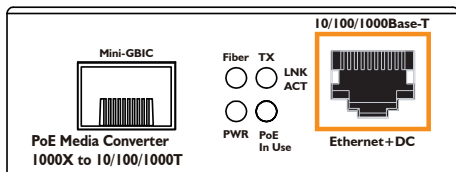

Figure 3-2: Left View of FCU-2805P-SFP

## Right View

One DIP switch for Link Fault Pass Through (LFP) features an, "ON" switch to turn-on the LLCF and LLR detection and an "OFF" switch to turn off this feature. Please refer to the following Link Fault Pass Through (LFP) and Link Loss Carry Forward (LLCF) sections for more information. Also found is one DC 52V ~ 56V power socket for the PoE+ Media Converter.

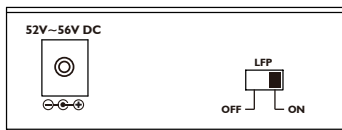

Figure 3-3: Right View of FCU-2805P-SFP

## 4. Link Fault Pass Through (LFP)

The LFP function includes the Link Fault Pass Through function (LLCF/LLR) and the DIP Switch design. LLCF/LLR can immediately alarm administrators to a link media problem and provide an efficient solution to monitor the net. The DIP Switch allows you to disable or enable the LFP function.

LLCF (Link Loss Carry Forward) is when a device is connected to the converter and the TP line loses the link, the converter's fiber will disconnect the link of transmit. LLR (Link Loss Return) means when a device is connected to the converter and the fiber line loses the link, the converter's fiber will disconnect the link of transmit. Both can immediately alarm administrators of a link media problem and provide an efficient solution to monitor the net.

### Link Loss Carry Forward (LLCF)

The FCU-2805P-SFP incorporates an LLCF function for troubleshooting a remote connection. When the LFP function is enabled, the FL / TP ports do not transmit a link signal until they receive a link signal from the opposite port.

The diagram below shows a typical network configuration with a good link status using FCU-2805P-SFP for remote connectivity.

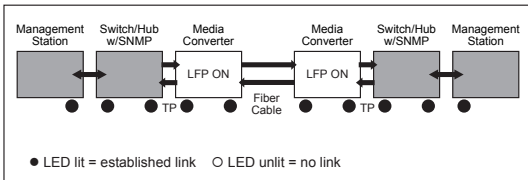

If the connection breaks, the FCU-2805P-SFP link loss forwards to the Switch / Hub and generates a trap to the management station. The administrator can then determine the source of the problem.

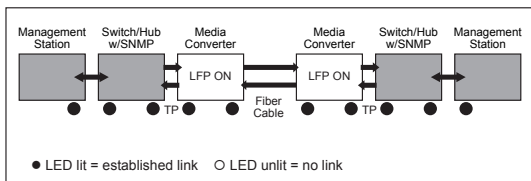

\*Units are shipped with the LFP function disabled (OFF).

## Link Loss Return (LLR)

The fiber ports of the FCU-2805P-SFP have been designed with an LLR function for troubleshooting a remote connection. LLR works in conjunction with LLCF.

When LFP function is enabled, the port's transmitter shuts down when its receiver fails to detect a valid receive link. LLR should only be enabled on one end of the link and is typically enabled on either the unmanaged or remote device.

The diagram below shows a typical network configuration with a good link status using FCU-2805P-SFP for remote connectivity. Note that LLR and LLCF are enabled as indicated in the diagram.

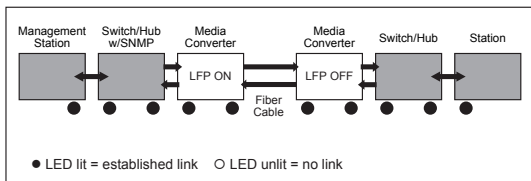

If one of the optical conductors is down (as shown in the diagram box below), the converter with LLR function will return a no-link condition to its link partner. With the LLCF function also enabled, the no-link condition is carried forward to the switch/hub where a trap is generated to the management station, and the administrator can then determine the source of the loss.

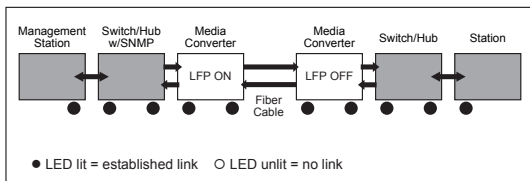

#### Note

LFP function is turned-off in default. This feature can also be turned on/off via the side DIP-switch. If you are not familiar with the network installation for diagnostic purposes (i.e. check which end is broken), you can turn it on and reset the converter to make it take effect. Otherwise, please keep it in the default position.

---

## ***5. Installing the Converter***

Please follow these steps to install the PoE+ Media converter:

1. Turn off the power of the device / station in a network to which the FCU-2805P-SFP will be attached.
2. Ensure that there is no activity in the network.
3. Attach fiber cable from the FCU-2805P-SFP to the fiber network.
4. Attach a Cat.5 / 5e / 6 UTP cable from the 10/100/1000Base-T network to the RJ-45 port on the FCU-2805P-SFP.
5. Connect the 52V~56V DC power adapter to the GTP-80X and verify that the Power LED lights up.
6. Turn on the power of the device / station, the TX Link and FX Link LEDs should light when all cables are attached.

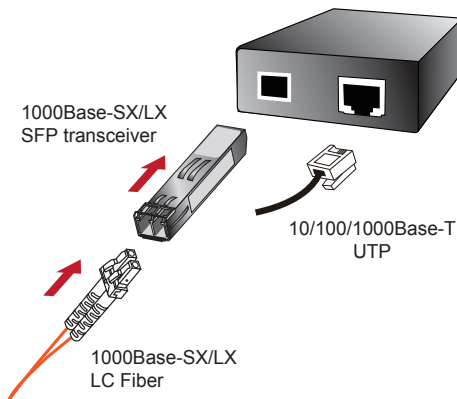

**Figure 5-1:** FCU-2805P-SFP Installation



**Note**

RJ-45 / STP, UTP Cat5 / 5e / 6, straight / cross-over cable is accepted.

Please refer to section 9 for more about the wiring distance of your TP, Optic-fiber networks.

## 6. PoE Function

### FCU-2805P-SFP and the IEEE 802.3at / 802.3af Injector / Splitter equipment installation:

Before your installation, we recommend that you check your network environment. If there are any IEEE 802.3at / 802.3af devices needed to be powered on, the FCU-2805P-SFP can provide you a way to supply power for this Ethernet device conveniently and easily.

The FCU-2805P-SFP is equipped with an AC-DC adapter with DC 52V~56V input that injects the DC power into the pin of the twisted pair cable (Pin 1, 2, 3 and 6).

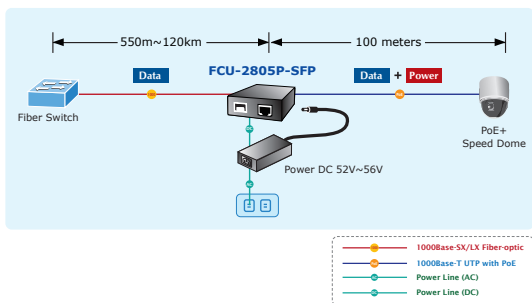

For places that prove difficult to find a power inlet, the FCU-2805P-SFP provides the easiest way to power your Ethernet devices with an Internet Camera or PoE Wireless Access Point installed in the wild range place.

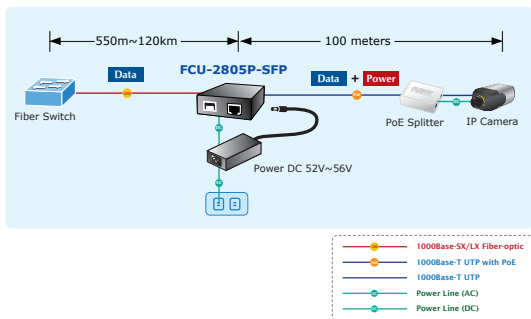



## 7. LED Indication

### System

| LED | Color | Function     |                                  |
|-----|-------|--------------|----------------------------------|
| PWR | Green | <b>Light</b> | Indicates the device is powered. |

### 10/100/1000Base-T Port

| LED        | Color  | Function     |   |
|------------|--------|--------------|---|
| LNK/ACT    | Green  | <b>Blink</b> | Indicates that the PoE+ Media Converter is actively sending or receiving data over that port. |
|            |        | <b>Light</b> | Indicates that the port is link up at 10/100/1000Mbps.  |
|            |        | <b>Off</b>   | Indicates that the port is link down.   |
| PoE in Use | Orange | <b>Light</b> | Indicates that the port is providing DC 52V to remote powered device.                         |
|            |        | <b>Off</b>   | Indicates that the port is not providing DC 52V to remote powered device.                     |

### 1000Base-X Fiber Port

| LED     | Color | Function     |   |
|---------|-------|--------------|---|
| LNK/ACT | Green | <b>Blink</b> | Indicates that PoE+ Media Converter is actively sending or receiving data over that port. |
|         |       | <b>Light</b> | Indicates that port is link up.   |
|         |       | <b>Off</b>   | Indicates that port is link down.   |

## 8. Cable Connection Parameter

The limitations are as below:

| Duplex                                | Connection                         | Limitation (max.)  |
|---------------------------------------|------------------------------------|--------------------|
| <b>Twisted Pair</b>                   |                                    |                    |
| Half / Full                           | Node to Node<br>Node to Switch/Hub | 100 meters         |
| <b>Multi-Mode Converters</b>          |                                    |                    |
| MM Half                               | Node to Node<br>Node to Switch     | 412 meters         |
| MM Full                               | Node to Node<br>Node to Switch     | 220 / 550 meters   |
| <b>Single-Mode Converters</b>         |                                    |                    |
| SM Full                               | Node to Node<br>Node to Switch     | 10 kilometers      |
| <b>Multi / Single Mode Converters</b> |                                    |                    |
| Full                                  | Node to Node<br>Node to Switch     | Vary on SFP module |

---

## 9. FCU-2805P-SFP Technical Specifications

The FCU-2805P-SFP comes with the following standard features:

- **Standard:** IEEE 802.3 / 802.3u / 802.3ab, 10/100/1000Base-T and IEEE 802.3at / 802.3af Power over Ethernet standard
- **Connectors:**
  - 1 x RJ-45 (Auto-MDI/MDI-X) Twisted Pair, EIA568 w/ PoE
  - 1 x Fiber-optic, connector-type vary with model
- **Data Transfer Rate:** 10/100/1000Mbps (TP), 1000Mbps (Fiber)
- **Duplex mode support:** Full or Half-duplex mode by Auto-Negotiation (TP)
- **LED Indicators:** PWR, FX LNK/ACT, TP LNK/ACT, PoE in Use
- **PoE Power Output:** DC 52V, Max. 30 Watts
- **Power Pin Assignment:** 1/2(+), 3/6(-) / End-Span
- **Power Supply:** DC 52V, 0.58A, external AC-DC adapter
- **Ambient Temperature:** 0° to 50°C (operating)
- **Humidity:** 5% to 90% (non-condensing)
- **Dimension:** 26 x 70 x 94mm (H x W x D)
- **Cable:**
  - UTP: Cat 5 / 5e / 6 UTP cable
  - Fiber: MM: 50/125 µm or 62.5/125 µm optic fiber
  - Fiber: SM: 9/125 µm optic fiber

Connecting to Router, Bridge, Switch, or Hub, please refer to the device's Technical Manual.

## APPENDIX A

### A.1 Device's RJ-45 Pin Assignments

#### 1000Mbps, 1000Base-T

| RJ-45 Connector pin assignment |        |        |
|--------------------------------|--------|--------|
| Contact                        | MDI    | MDI-X  |
| 1                              | BI_DA+ | BI_DB+ |
| 2                              | BI_DA- | BI_DB- |
| 3                              | BI_DB+ | BI_DA+ |
| 4                              | BI_DC+ | BI_DD+ |
| 5                              | BI_DC- | BI_DD- |
| 6                              | BI_DB- | BI_DA- |
| 7                              | BI_DD+ | BI_DC+ |
| 8                              | BI_DD- | BI_DC- |

#### 10/100Mbps, 10/100Base-TX

| RJ-45 Connector pin assignment |                               |  |
|--------------------------------|-------------------------------|--|
| Contact                        | MDI Media Dependant Interface | MDI-X Media Dependant Interface -Cross |
| 1                              | Tx + (transmit)               | Rx + (receive)                         |
| 2                              | Tx - (transmit)               | Rx - (receive)                         |
| 3                              | Rx + (receive)                | Tx + (transmit)                        |
| 4, 5                           | Not used                      |  |
| 6                              | Rx - (receive)                | Tx - (transmit)                        |
| 7, 8                           | Not used                      |  |

Implicit implementation of the crossover function within a twisted-pair cable, or at a wiring panel, while not expressly forbidden, is beyond the scope of this standard.

## A.2 RJ-45 Cable Pin Assignment

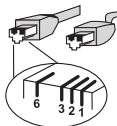

There are 8 wires on a standard UTP/STP cable and each wire is color-coded. The following shows the pin allocation and color of straight cable and crossover cable connection:

| <u>Straight Cable</u> |   | <u>SIDE 1</u>    | <u>SIDE 2</u>    |
|-----------------------|---|------------------|------------------|
| 1                     | 1 | 1 = White/Orange | 1 = White/Orange |
| 2                     | 2 | 2 = Orange       | 2 = Orange       |
| 3                     | 3 | 3 = White/Green  | 3 = White/Green  |
| 4                     | 4 | 4 = Blue         | 4 = Blue         |
| 5                     | 5 | 5 = White/Blue   | 5 = White/Blue   |
| 6                     | 6 | 6 = Green        | 6 = Green        |
| 7                     | 7 | 7 = White/Brown  | 7 = White/Brown  |
| 8                     | 8 | 8 = Brown        | 8 = Brown        |

---

| <u>Crossover Cable</u> |   | <u>SIDE 1</u>    | <u>SIDE 2</u>    |
|------------------------|---|------------------|------------------|
| 1                      | 3 | 1 = White/Orange | 1 = White/Green  |
| 2                      | 6 | 2 = Orange       | 2 = Green        |
| 3                      | 1 | 3 = White/Green  | 3 = White/Orange |
| 4                      | 4 | 4 = Blue         | 4 = Blue         |
| 5                      | 5 | 5 = White/Blue   | 5 = White/Blue   |
| 6                      | 2 | 6 = Green        | 6 = Orange       |
| 7                      | 7 | 7 = White/Brown  | 7 = White/Brown  |
| 8                      | 8 | 8 = Brown        | 8 = Brown        |

**Figure A-1:** Straight-Through and Crossover Cable

Please make sure your connected cables are with the same pin assignment and color as above picture before deploying the cables into your network.

### A.3 Fiber Optical Cable Connection Parameter

The wiring details are as below:

#### Fiber Optical Patch Cables:

| Standard             | Fiber Type  | Cable Specification                |
|----------------------|-------------|------------------------------------|
| 1000Base-SX (850nm)  | Multi-mode  | 50/125 $\mu$ m or 62.5/125 $\mu$ m |
| 1000Base-LX (1300nm) | Multi-mode  | 50/125 $\mu$ m or 62.5/125 $\mu$ m |
|                      | Single-mode | 9/125 $\mu$ m                      |

