



Model SAF205H Electronic Handheld Siren



Installation and operation manual

Notice to installer

Before installation and use -- read all instructions and warnings.
Deliver this manual to the end user of this equipment.

Doc. No.: SAF205H Siren_v.1

www.cell2.com

Table of Contents

GENERAL DESCRIPTION.....	2
SPECIFICATIONS.....	3
INSTALLATION.....	4
CONTENTS.....	4
MOUNTING.....	4
WIRING.....	5
Electrical Connections.....	5
Light Control Connections.....	7
PROGRAMMING.....	8
OPTION SWITCHES.....	10
OPERATION.....	11
POWER (ON/OFF).....	11
SIREN CONTROLS.....	11
Hands-Free Button.....	11
Siren Button.....	12
Radio Button.....	12
Manual Button.....	12
Horn Button.....	12
PA.....	12
HRT Input (optional).....	12
PKL Input (optional).....	12
LIGHT CONTROLS.....	13
LV Buttons.....	13
Auxiliary Buttons.....	13
TROUBLESHOOTING.....	14

GENERAL DESCRIPTION

The SAF205H Handheld Siren Amplifier is a premium 200W unit designed for single or dual 100W speaker use with full lighting control. A remote handheld controller is connected to the amplifier with a thin cable. The control head comes with a noise-canceling microphone for PA use and push-button override in all modes. It contains illuminated buttons that change color to indicate status. A potentialmeter is also provided on the controller to adjust PA volume. The SAF205H also includes 3 push buttons for primary lighting system control and 4 auxiliary output push buttons; each button is capable of 10 amps current. There are 3 primary operation modes: HandsFree, Siren, and Radio with a Horn button Override and a Manual button Override. The Radio and Siren volume can be adjusted on the side of the siren amplifier.

A Horn Ring Transfer input is available for the connection to vehicle horn ring or remote switch for hands-free siren operation. A Park Kill input is available for connection to a door switch, etc. to stop siren tones when exiting the vehicle. A 16-position DIP switch on the amplifier allows selection of various options. The handheld controller is backlit with LED's for night visibility.

front view Handheld controller

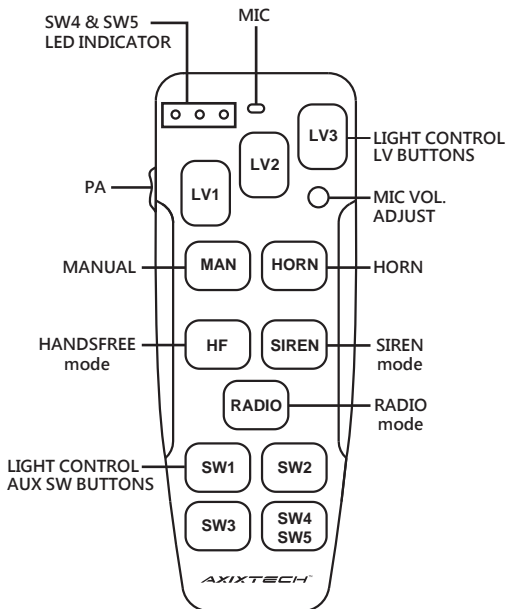

front view (Light control connector)

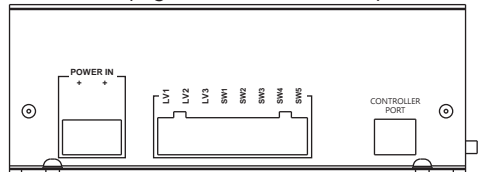

side view (12-Pin Siren Connector)

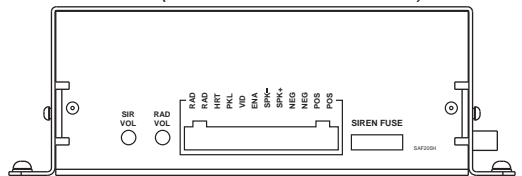

side view (DIP switches)

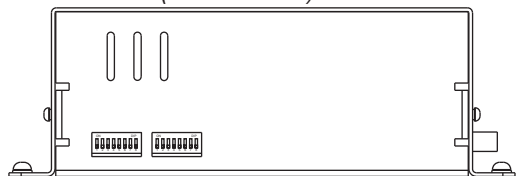

SPECIFICATIONS



Input Voltage	10-16VDC (negative ground)				
Siren Input Current	8.5Amps (@13.6VDC - single 100W speaker)				
	16Amps (@13.6VDC - dual 100W speakers)				
Siren Standby Current	Less than 150mA				
Audio Frequency	200Hz - 10kHz \pm 3db				
Siren Output Power	40 watts (@13.6VDC-single 100W speaker)				
Siren Output Power	100 Watts RMS MAX. (14VDC - single 100W speaker)				
	200 Watts RMS MAX. (14VDC - dual 100W speakers)				
Siren Frequency	725Hz - 1465Hz				
Tones/ Cycle Rates	HORN	WAIL	YELP	PHASER	HILO
Cycle Rates	Composite (Constant)	12CPM	190CPM	650CPM	60CPM
Operating Temp	-25° C to +60° C (-15° F to +140° F)				
Siren Controls	3 push-button Mode switch (SIREN, HF, RADIO).				
	Momentary push-button Horn switch.				
	Momentary push-button Manual/Tone toggle switch.				
	ENA input (positive) to turn on unit.				
	HRT input programmable for positive or negative operation.				
	PKL input programmable for positive or negative latching operation.				
	Side DIP switch option selectors.				
Light Controls	3 push-button switch with position 3 siren activation and LED indicators.				
	4 - on/off lighted push-button switches with replaceable legends.				
Light Output Ragings	10A fuse on each of the 8 outputs. (LV - 3 push buttons & SW - 4 push buttons)				
Siren Connections (Removable 12-P Terminal Block)	Positive x 2, Negative x 2, Speaker x 2, Radio x 2, Enable, Park Kill, Horn Ring Transfer, Park Kill.				
Light Control Connections	Power In 2-position screw terminal inputs.				
	LV1, LV2, LV3 (push buttons) 3-position screw terminal outputs.				
	SW1, SW2, SW3, SW4 (push buttons) 5-position screw terminal outputs.				
Size	Siren Amplifier 20.8cm x 18.8cm x 6.9cm Controller: 5.6cm x 14cm x 3.3cm				
Boxed Weight	2.5kg				

INSTALLATION

It is essential to install the unit properly to ensure safe and reliable operation. Please read through all instructions thoroughly and carefully before installing the unit. Failure to follow these instructions could result in serious damage to the unit or vehicle and may void warranties.

The correct mounting and wiring is key to the effectiveness of SAF205H siren. Installers must read and follow installation instructions and warnings in the manual from original manufacturer. The vehicle operator should verify the siren system is fastened to the vehicle securely and is functioning properly. Failure to follow all safety precautions and instructions may cause property damage, injury, or death.

WARNING: The installer must have good knowledge of electricity, vehicle electrical systems and emergency equipment. Always seek professional assistance if in doubt.

		WARNING Sound Hazard - Sound level from siren speaker (>120dBA @ 10 feet) may cause hearing damage. Do not operate siren without adequate hearing protection for you and anyone in immediate vicinity. (Ref. OSHA 1910.95 for occupational noise exposure guidelines)
--	---	---

CONTENTS

Inspect the product contents carefully to see if there is shipping damage or missing content. Contents include:

- | | |
|---|---------------------------------|
| 1pc – Siren (Amplifier) | 1pc – 6’ Extension Cable |
| 1pc – Handheld Controller with Coil Cord | 1pc – Extension Cable Connector |
| 1pc – Handheld Controller Mounting Bracket | 1pc – 15 Button Plate |
| 1pc – 12-Pin Siren Input Connector | 1pc – Button Decals |
| 1pc – 2-Pin Light Control Power Input Connector | 1pc – User Manual |
| 1pc – 8-Pin Light Control Output Connector | 1pc – Operation Warning Label |

Please contact supplier immediately if any component is missing or damaged.

MOUNTING

Mount the siren unit in a location that is not exposed directly to weather elements such as the driver compartment firewall, below the seat, or in the trunk; and away from any air bag deployment areas. Mount the handheld controller in an area where it can be easily accessed by the vehicle operator, and not affect the vehicle the air bag. Be sure that all wiring harness connections are made prior to connecting the harness to the amplifier unit.

WARNING: Do not interfere with the proper operation of the vehicle airbag deployment system. Ensure to install “Operation Warning Label” in the vehicle in an area that is clearly visible to operators and passengers.

WIRING

Use wires that are capable of handling the required current. Route the wires properly to prevent wear, overheating and interference with air bag deployment. Ensure that all connections are tight and double check wiring before connecting to the vehicle battery.

ELECTRICAL CONNECTIONS

Electrical connections to the unit are made by using block plugs and screw terminals. Route all wiring to the siren and secure onto block plug terminals, then plug onto the siren. The plug can be easily removed without unwiring when the unit requires servicing. The power supply for the fused amplifier (12-P plug) must be capable of delivering peak currents up to 50A for adequate short circuit protection and proper operation. It is recommended to wire directly to the vehicle battery.

WARNING: ensure that all wires are firmly secured onto the block plug, and plug is firmly secured onto the siren.

Wire Size and Termination – The “AMPLIFIER CONNECTIONS” diagram shows the minimum size of the wires used for each connection, along with recommended lead color. If the wire is longer than 10 ft., use the next larger size.

ENA Input Connection – This serves as the power switch for the entire unit. Connect to a positive circuit controlled by the vehicle ignition switch, usually a terminal at the vehicle fuse panel. It is not recommended to make permanent power connection as this may drain battery.

HRT Input Connection – The Horn Ring Transfer input allows activation by an external source of either the Horn or other function. It can be set for positive or negative switching, see DIP-SW1-1 (HRT_N) under OPTION SWITCHES section.

PKL Input Connection – The Park Kill input may be connected to the vehicle door switch or other switching device to turn off any siren tone when activated. It can be set for positive or negative switching, see DIP-SW1-2 (PKL_N) under OPTION SWITCHES section.

RAD Input Connection – Connect to radio output terminals or its speaker. The Radio volume can be adjusted by using a small flat blade screwdriver.

Speaker Output Connection – Both connections must be used. Two speakers may be connected in parallel.

VID Output Connection (Option) – A Video Camera trigger output is activated when ever the unit is in SIREN or HF mode. (Not available in this model).

AMPLIFIER CONNECTIONS

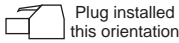
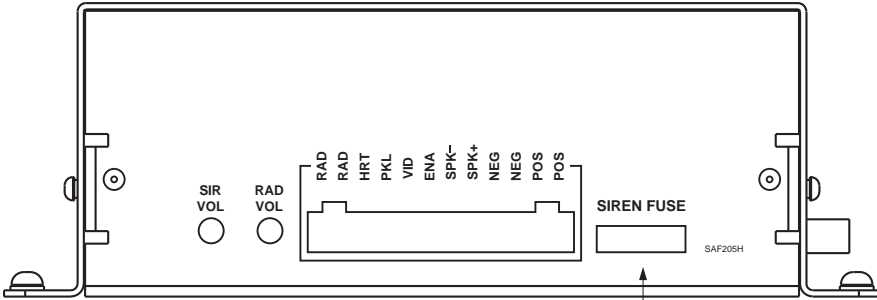

12-P Terminal Block Plug

20A Automotive Type Fuse

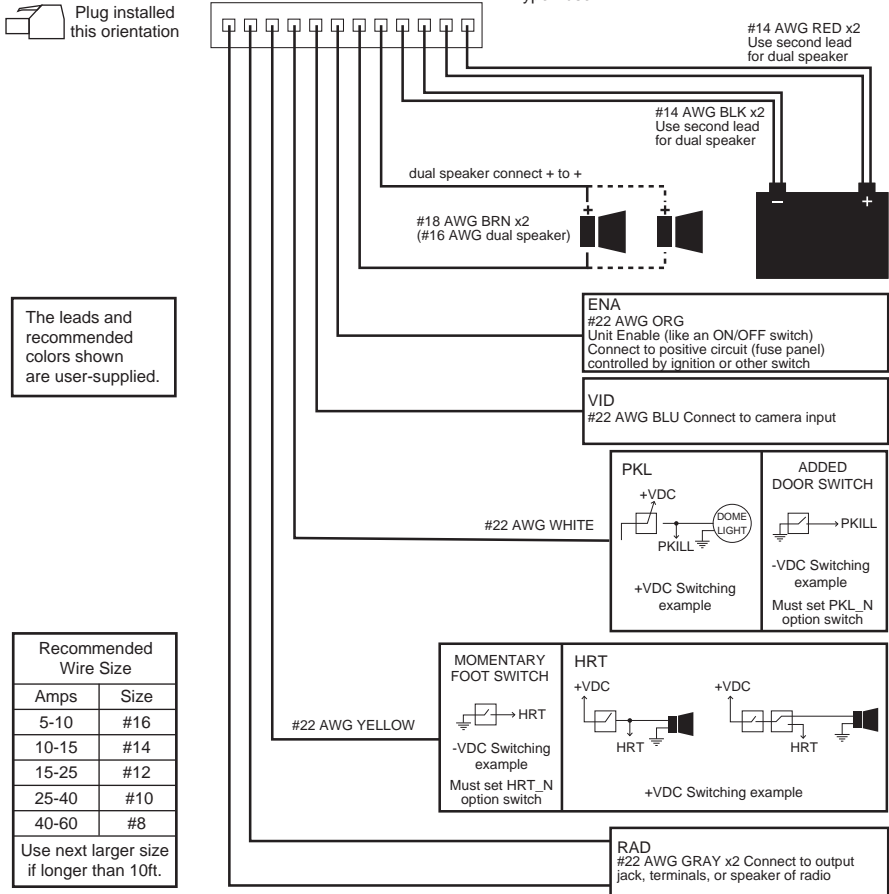

The leads and recommended colors shown are user-supplied.

Recommended Wire Size	
Amps	Size
5-10	#16
10-15	#14
15-25	#12
25-40	#10
40-60	#8

Use next larger size if longer than 10ft.

LIGHT CONTROL CONNECTIONS

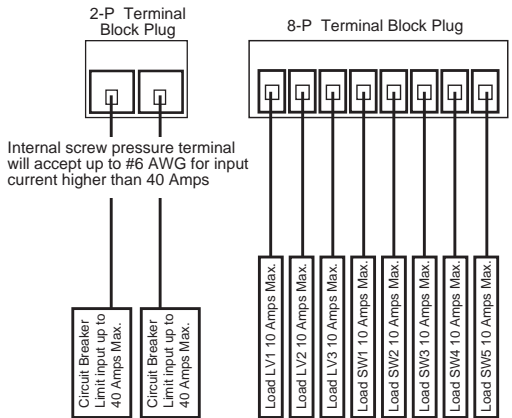
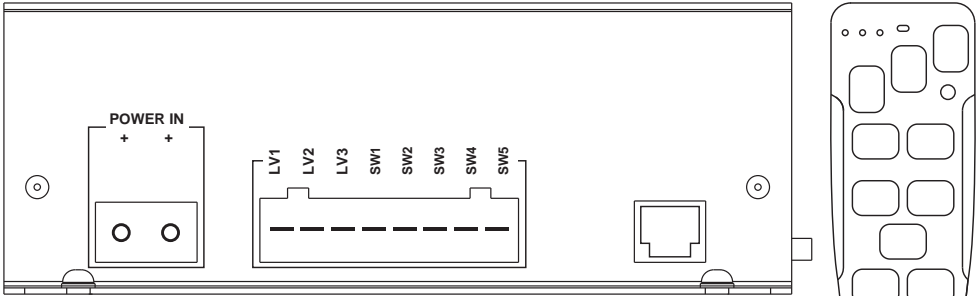

Internal screw pressure terminal will accept up to #6 AWG for input current higher than 40 Amps

Circuit Breaker
Limit input up to
40 Amps Max.

Circuit Breaker
Limit input up to
40 Amps Max.

Load LV1 10 Amps Max.
Load LV2 10 Amps Max.
Load LV3 10 Amps Max.
Load SW1 10 Amps Max.
Load SW2 10 Amps Max.
Load SW3 10 Amps Max.
Load SW4 10 Amps Max.
Load SW5 10 Amps Max.

Recommended Wire Size	
Amps	Size
5-10	#16
10-15	#14
15-25	#12
25-40	#10
40-60	#8
Use next larger size if longer than 10ft.	

Hand held controller

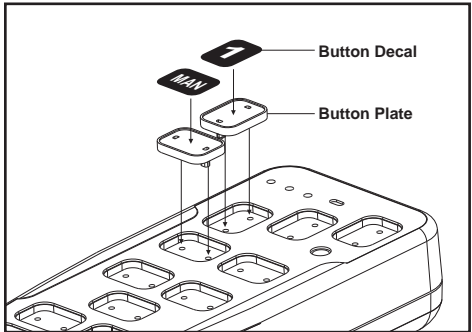

NOTE: The controller is shipped without any button plates or decals installed. Place decal onto button plates, then install plates onto each button.

LIGHT CONTROL CONNECTIONS

Power – The power input for the light controls (the three LV switches and the four auxiliary control switches) are separate from the power inputs for siren. This design helps prevent a fault in one main circuit from affecting another main circuit.

Fuses/Breakers – Each light control output is fused and should be limited to 10 Amps. Proper rated circuit breakers should be connected between the power source and light control power inputs. Refer to “FUSE LOCATION” diagram for proper fuse location below.

WARNING: Improper circuit breakers or fuses can result in damage to the unit and/or vehicle.

FUSE LOCATION (open siren top view)

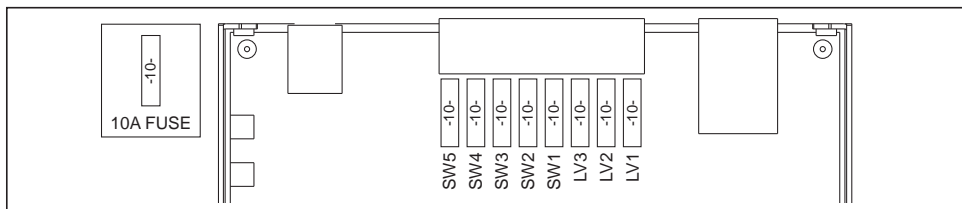

PROGRAMMING

Once the electrical connections are made and the power is available to the unit, each of the three LV buttons and four auxiliary control buttons are ready to be programmed. The programming mode is entered by changing the DIP switch.

Follow these steps to program the unit:

Get into program mode.

1. Turn unit on with enable input.
2. Enter the program mode by turning DIP-SW2-8 (PRG) switch on.

Set Auxiliary Control Buttons Operation (all LV buttons off)

1. With all LV buttons off, each auxiliary switch current operation program status is indicated on each push button. See the table below for switch status definition.
2. Change button operation by momentarily pushing the auxiliary button.

LED showing	AUXILIARY button setting
Red Steady	PUSH on / PUSH off (default)
Red Flashing	MOMENTARY
Red off	TIMED MOMENTARY (10 seconds)

NOTE: The Timed Momentary operation, typically used as a Gun Lock Timer, must begin with push button 3. If push button 3 is programmed as timed momentary, only then push button 2 may be programmed also as a timed momentary and so on.

Each LV button (LV1, LV2, LV3) may be programmed to automatically turn on any of the auxiliary button controls (SW1~SW3) except Timed Momentary. These auxiliary button controls may still be operated manually even if they were turned on automatically. Each time the LV button changes position, the combined auxiliary button controls are turned on or off. When the LV button is turned off, the entire auxiliary button controls tied to a position on the LV button is turned off while the other auxiliary buttons are unaffected.

Set LV buttons (LV1, LV2, LV3) and Auxiliary buttons Combination

1. Activate desired LV button to program.
2. Press the desired auxiliary button to change LED color to Red. Press the auxiliary button again to change LED color to Green to remove from combination.
3. Once the LV buttons are programmed as desired, save and exit programming mode by turning DIP-SW2-8 (PRG) switch off.

NOTE: If the unit is turned off before the DIP-SW2-8 (PRG) switch is turned off, the new programming will not be saved.

OPTION SWITCHES

Various options can be selected by turning on or off DIP switches located on the side of the siren. The DIP SWITCH functions are described below. (see Appendix 1 for quick reference)

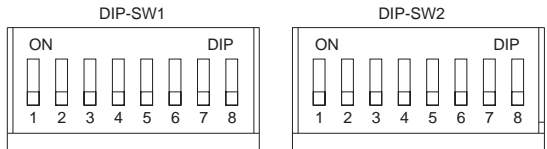

DIP-SW1-1 (HRT_N) HRT Input Polarity – The HRT input is normally activated by a positive voltage. Set switch on to activate with negative.

DIP-SW1-2 (PKL_N) PKL Input Polarity – The PKL input is normally activated by a positive voltage. Set switch on to activate with negative.

DIP-SW1-3 (HILO) – HiLo tone replaces Phaser tone by setting this switch on.

DIP-SW1-4 (PHASER_D) – Phaser/HiLo tones are disabled by setting this switch on.

DIP-SW1-5 (HORN_D) – Horn tone is disabled by setting this switch on.

DIP-SW1-6 (SIREN_SW1) – See “Siren Mode settings” chart.

DIP-SW1-7 (SIREN_SW2) – See “Siren Mode settings” chart

DIP-SW1-8 (TA_D) – With this switch off, the handheld LED indicator operates in Traffic Arrow mode. With this switch on, the Traffic Arrow mode is disabled.

Press SW4 button:	Handheld controller LED Indicator	
	With DIP-SW1-8 off (Traffic Arrow mode)	With DIP-SW1-8 on (Regular mode)
1st Press	LED flashes right to left	Left LED on
2nd Press	LED flashes left to right	Right LED on
3rd Press	LED flashes center out	Left and Right LEDs on
4th Press	all LEDs off	all LEDs off

DIP-SW2-1 (HRT_HF_HORN) – With this switch off, when in HF mode, Horn Ring will not produce Horn tone. With this switch on, when in HF mode, pressing Horn Ring for more than 0.5 seconds produces Horn tone.

DIP-SW2-2 (HRT_STBY_D) – With this switch off, when in standby (ie. no modes selected), pressing Horn Ring or RAD button produces Horn tone. With this switch on, Horn Ring will not produce Horn tone.

DIP-SW2-3 (MAN_CHANGE) – With this switch off, pressing MAN button momentarily produces next tone. With this switch on, pressing MAN button changes to next tone.

DIP-SW2-4 (SHORT_MAN) – With this switch off, MAN Siren tone slowly winds down when released. With this switch on, MAN Siren tone stops immediately when released.

DIP-SW2-5 (LV_SW1) – See LIGHT CONTROLS section.

DIP-SW2-6 (LV_SW2) – See LIGHT CONTROLS section.

DIP-SW2-7 (AUTSR_D) – With this switch off, Siren tone is automatically activated when LV3 button is activated. With this switch on, Automatic Siren tone is disabled.

DIP-SW2-8 (PRG) – Turn this switch on to enter Programming mode; see PROGRAMMING section.

OPERATIONS

POWER (ON/OFF)

The unit can be activated by applying positive voltage to the ENA terminal in the amplifier. Normally, this is wired to the ignition switch of the vehicle; it can also be wired to another switch to act as ON/OFF. See “AMPLIFIER CONNECTIONS” diagram.

SIREN CONTROLS

There are 5 buttons in the middle area of the handheld controller dedicated for primary operating modes of the siren.

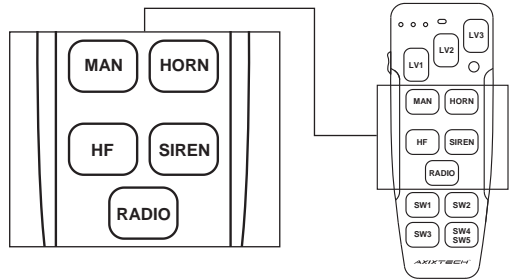

Function modes

Modes	Standard	+ MAN button	+ HRT trigger
Standby (no mode selected)	SILENT	MANUAL / SHORT MANUAL see DIP-SW2-4 SHORT_MAN	HORN / SILENT see DIP-SW2-2 HRT_STBY_D
RADIO	RADIO	RADIO	HORN / RADIO see DIP-SW2-2 HRT_STBY_D
HF	SILENT	CYCLER (see HF settings)	CYCLER (see HF settings)
SIREN	WAIL (see Siren Mode)	YELP (see Siren Mode)	YELP (see Siren Modes)

HF – This is a standby mode dedicated for HRT (Horn Ring Transfer). When installing the unit, the auxiliary input must be connected to the horn ring or other switching device. Tap the horn ring or MAN button once to activate Wail tone, then tap again to activate Yelp tone, and quickly tap the horn ring twice to shut off siren tone. By setting DIP-SW2-1 on, pressing and holding the horn ring will produce Horn tone until released, then the siren will return to its previous siren tone.

HF settings

Press Horn Ring:	PHASER_D off		PHASER_D on	
	HILO off	HILO on	HILO off	HILO on
HRT tap once (MAN press once)	SILENT-> WAIL-> YELP-> PHASER	SILENT-> WAIL-> YELP-> HILO	SILENT -> WAIL -> YELP	
HRT quickly tap twice (MAN quickly tap twice)	SILENT			
HRT press +0.5 secs	SILENT (with DIP-SW2-1 off) HORN (with DIP-SW2-1 on)			

SIREN – This button will activate Wail tone. When pressing with MAN button together, it will produce Yelp tone. See Siren Modes chart.

Siren Modes

MODE	SIREN_SW1 off	SIREN_SW1 off	SIREN_SW1 on
	SIREN_SW2 off	SIREN_SW2 on	SIREN_SW2 ---
SIREN	WAIL	YELP	PHASER (see PHASER settings)
SIREN + MAN (or HRT) (w/ MAN_CHANGE off)	YELP	PHASER (see PHASER settings)	YELP
SIREN + MAN (or HRT)	WAIL / YELP	YELP / PHASER (see PHASER settings)	PHASER / YELP (see PHASER settings)

RADIO – This function amplifies the radio speaker input for re-broadcast outside the vehicle. It is also known as Radio Re-broadcaster, and no siren tones are available in this position. The Radio Volume can be adjusted via potentiometer on the siren amplifier unit.

MAN – It provides manual control of siren tone rise and fall while in Standby, HF or SIREN modes. See “Function Modes” chart.

HORN – It provides a simulated air-horn tone when pressed, and overrides all siren tones. The Horn tone may be disabled entirely by setting the DIP-SW1-5 (HORN_D) option on. See OPTION SWITCHES section.

PA – The noise-canceling microphone is used for public address operation. It will override any siren mode when the button on the side is pressed. The volume can be adjusted through a pot switch located in the upper right corner of the control head. Insert a small, flat-blade screwdriver into the pot switch; turn clockwise direction to increase the sound level.

HRT Input (optional) – The Horn Ring Transfer input may be connected to the horn ring or other switching devices. Activating this input will produce Horn tone or other functions depending on the push button position.

PKL Input (optional) – The Park Kill input may be connected to the vehicle door switch or other switching device to turn off any siren tone when activated. The siren will remain deactivated until the vehicle is shifted into gear or the door is closed and the siren is automatically restarted.

LIGHT CONTROLS

The 3 LV buttons (LV1, LV2, LV3) in the top area of the handheld controller are dedicated for primary lighting functions. There are additional 4 programmable on/off buttons for auxiliary lighting or other devices.

LV buttons – The LV buttons can be set to operate as a Progressive or Non-progressive switching. There are four modes available.

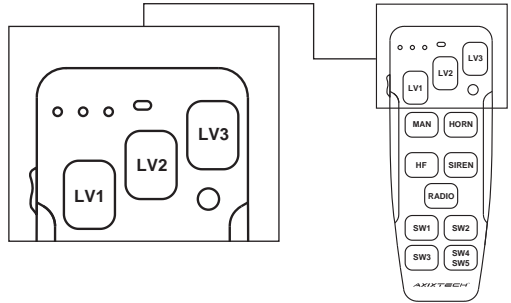

LV Button Modes

LV Button Modes:	MODE1 LV_SW1 off LV_SW2 off	MODE2 LV_SW1 off LV_SW2 on	MODE3 LV_SW1 on LV_SW2 off	MODE4 LV_SW1 on LV_SW2 on
LV1	LV1	LV1	LV1 ∩ LV3	LV1
LV2	LV2	LV2	LV2 ∩ LV3	LV1 ∩ LV2
LV3	LV1 ∩ LV2 ∩ LV3	LV3	LV1 ∩ LV2 ∩ LV3	LV1 ∩ LV2 ∩ LV3

Progressive/Non-progressive Switch - There are 4 different combination modes available. This is configured by setting the DIP-SW 2-5 (LV_SW1) and DIP-SW 2-6 (LV_SW2) option. At each of the LV switches, it is possible to program the additional AUX on/off buttons to be activated together.

LV3 Button – When LV3 is switched on, the siren tone is automatically activated. This function can be disabled by setting the DIP-SW2-7 (AUTSR_D) option; see OPTION SWITCHES section.

VID Output Option – The VID output is activated whenever the unit is in SIREN or HF modes. (Available in future models).

AUXILIARY Buttons – The 4 lighted on/off buttons are for controlling other lighting functions or devices. SW1~SW3 buttons can be programmed for three operating modes such as Push On/Off, Momentary, or Timed momentary; see PROGRAMMING section. SW4 button is designed to control SW4 and SW5 outputs, which is mainly used to control the traffic arrow functions.

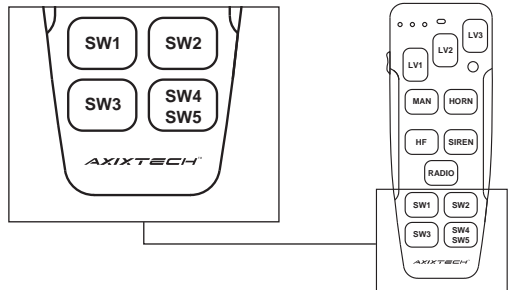

1st Press	Activates output SW4
2nd Press	Activates output SW5
3rd Press	Activates outputs SW4 & SW5
4th Press	Deactivates outputs SW4 & SW5

See DIP-SW1-8 (TA_D) for corresponding Handheld controller LED indicator.

TROUBLESHOOTING

SAF205H Siren has been designed to provide reliable quality service under the worst conditions. If encounter any difficulties, check its installation or speakers. The following table represents problems and probable causes.

PROBLEM	POSSIBLE CAUSE
NO SOUND	Loose wires or connectors Bad speaker or speaker wiring Siren fuse down PA volume in the lowest sound level
NO SIREN TONE-PA WORKS	High input voltage (greater than 16V) PKL activated PA button pressed Speaker not connected Defective speaker
DISTORTED SIREN SOUND	Bad speaker Damaged or loose speaker housing or tip Low voltage to siren amplifier Loose wires or connectors at ENA or SPKR
SIREN VOLUME LOW	Speaker connected to wrong tap Low voltage to siren amplifier High resistance in speaker wiring PA volume in low position
WEAK PA	Microphone no held close to mouth Defective microphone Microphone loose connection
INTERMITTENT	High input voltage (greater than 16V) Bad speaker driver Unused wires touching vehicle ground or supply

Appendix 1

DIP-SW1 Options

PORT	DIP-SW1	FUNCTIONS	
		OFF	ON
1-1	HRT_N	HRT activate with positive	HRT activate with negative
1-2	PKL_N	PKL activate with positive	PKL activate with negative
1-3	HILO	PHASER normal operation	PHASER replaced by HILO
1-4	PHASER_D	PHASER and HILO normal operation	PHASER and HILO disabled
1-5	HORN_D	HORN normal operation	HORN disabled (replaced by PHASER/HILO/YELP)
1-6	SIREN_SW1	for configuration of Siren tone (see "Siren Modes" chart)	
1-7	SIREN_SW2		
1-8	TA_D	LED Indicator as Traffic Arrow	LED Indicator Constant

DIP-SW2 Options

PORT	DIP-SW2	FUNCTIONS	
		OFF	ON
2-1	HRT_HF_HORN		
		During HF, HORN is disabled for HRT	During HF, press HRT for more than 0.5 secs produces Horn tone
2-2	HRT_STBY_D	During Standby, HRT and RADIO produces HORN tone.	During Standby and RADIO, HRT is disabled
2-3	MAN_CHANGE	During SIREN, press MAN produces next tone when pressed	During SIREN, press MAN skips to next tone when pressed
2-4	SHORT_MAN	MAN Siren tone slowly winds down when released	MAN Siren tone stops immediately when released
2-5	LV_SW1	for configuration of Progressive or Non-Progressive switching (see "LV Button Modes" chart)	
2-6	LV_SW2		
2-7	AUTSR_D	Automatic Siren at LV3	Automatic Siren Disabled at LV3
2-8	PRG	Operation Mode	Light Control Program Mode