



e-Tag
User Manual

Contents

By purchasing the Montblanc e-Tag you made a good decision. Please read this user manual with care to make the most of your e-Tag.

A. Getting Started

Box contents

Understanding your e-Tag

Opening the key ring

Charging the battery

Switching the e-Tag on/off

Installing the e-Tag app

Pairing the e-Tag with your iPhone

Reconnecting the e-Tag to another iPhone

B. Montblanc e-Tag app

Overview

Connecting your e-Tag

Home screen

Locate your e-Tag

Motion alarm

Turn alarm on/off

Settings

Last location

Reconnection notification

Managing your e-Tag connections

Safety zones and further settings

C. Safety instructions

D. Certification statements

E. End user licence agreement

F. Privacy policy

G. Terms of Use

H. Technical information

I. Disclaimer

A. Getting Started

The e-Tag can be located with your smartphone, alarm you when it is moved, send a notification if the e-Tag gets out of range and show you the area it was last located in. Attach it to your belongings to protect them against theft or loss. Follow this Getting Started chapter or the quick-start guide enclosed with the e-Tag to set up your e-Tag and connect it to your phone.

Box contents

The e-Tag comes with the following items:

- 1 x e-Tag
- 1 x micro-USB cable
- 1 x Quick-start guide
- 1 x Montblanc service guide

Understanding your e-Tag

The e-Tag consists of a key ring to attach it to your items and an electronic tag that connects via Bluetooth to your smartphone.

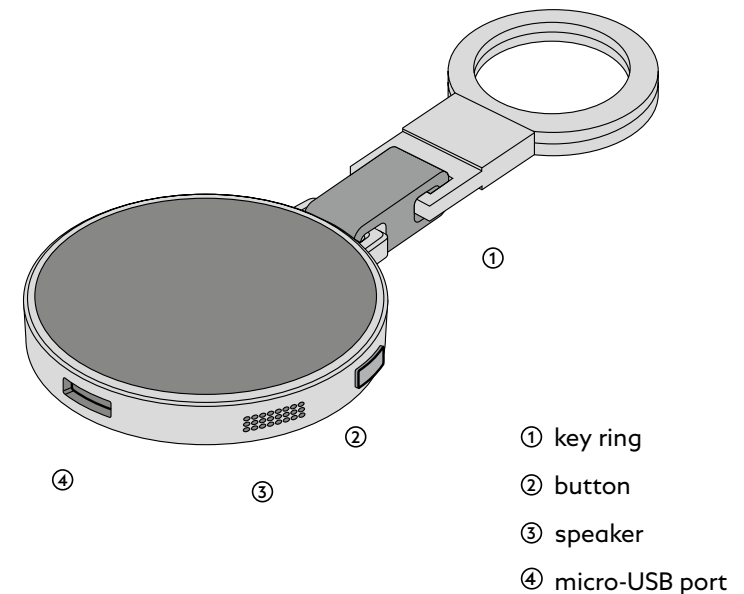

Opening the key ring

To open the key ring pull down the flat metal plate (1) and turn the ring to the left or right (2) until it opens up (3). Attach the e-Tag to one of your belongings and close the key ring again by turning it back.

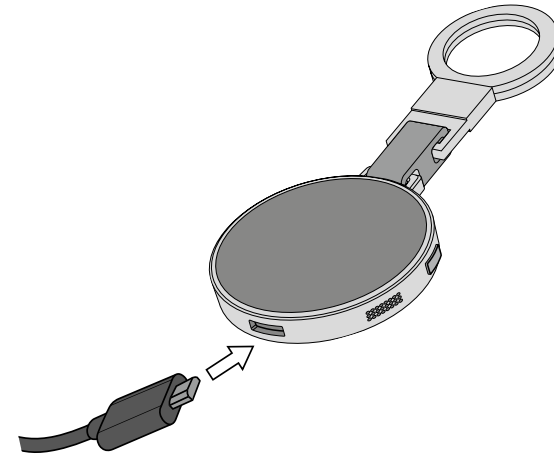
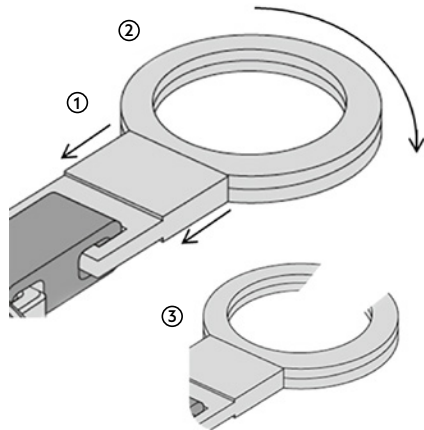

After approximately three hours of charging remove the USB cable first from the computing device or USB charger and then disconnect the micro-USB from the e-Tag. Please do not leave the e-Tag on prolonged charging, as it may harm the battery performance. The device runs with a rechargeable lithium - ion battery that provides power for a maximum of two weeks. The battery life may vary depending on your personal usage pattern and environmental conditions. You can check the battery status in the settings of the smartphone application.

Charging the battery

Use the enclosed Montblanc micro-USB cable to charge your e-Tag. Plug the micro-USB cable into the micro-USB port and plug the other end into the USB port of a computer or a suitable USB charger.

Switching the e-Tag on/off

To turn the device on/off press and hold the button on the e-Tag for three seconds. The e-Tag will make an ascending sound when turning on and a descending sound when turning off.

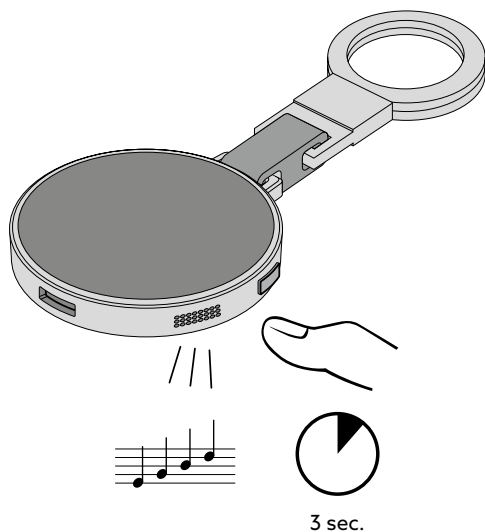

Installing the e-Tag app

The Montblanc e-Tag app is compatible with Apple iPhone 4S and later running iOS 8 and later. Other mobile devices are not supported.

To install the e-Tag app make sure that you have an active Wi-Fi or mobile network connection to access the App Store.

By clicking on the App Store logo below you will be forwarded to the app download.



You can also download the app by following these instructions:

1. Access the store from your phone by tapping on the "App Store" icon.
2. Tap the "Search" icon in the navigation bar.
3. Tap on the search field and type "Montblanc e-Tag".
4. Select the first search result from the list and tap on the "Load" button.

Pairing the e-Tag with your iPhone

The e-Tag is paired to your mobile phone using Bluetooth® Low Energy. Pairing enables the e-Tag to communicate continuously with your phone. The pairing process only needs to be carried out once.

Before pairing, please ensure the following:

1. Bluetooth on your phone is on
2. e-Tag is on
3. e-Tag is nearby
4. The app is up to date
5. Your phone has an active Internet connection

Turn Bluetooth® on

1. Swipe from bottom to top
2. Tap on the Bluetooth icon in the overlay



Connect the e-Tag to your iPhone

Launch the e-Tag app and make sure the e-Tag is charged. Turn the e-Tag on by pressing and holding the button on the device for three seconds. The e-Tag will make an ascending sound and connect to your smartphone.

Reconnecting the e-Tag to another iPhone

Once the e-Tag is paired, it cannot be used with another phone unless you unpair it. To reconnect the e-Tag to another phone follow these three steps.

1. **Remove the e-Tag from your app**

Tap on the "-" icon next to the e-Tag in order to remove it from the app.

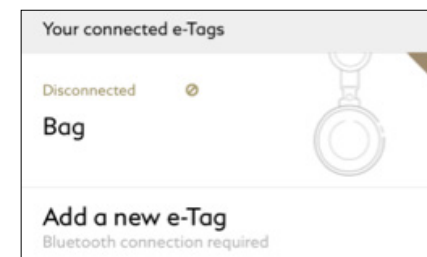

2. Unpair the e-Tag from your iPhone

Enter the iPhone settings and tap on Bluetooth.

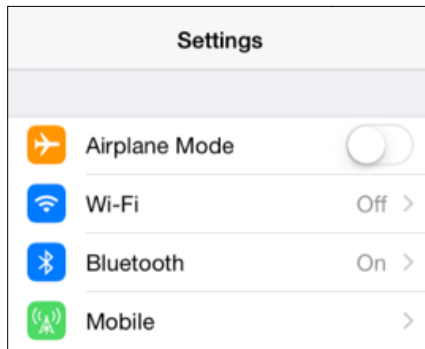

Tap on "Forget This Device".

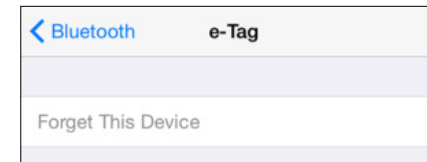

Press and hold the button of the e-Tag until it plays four short consecutive beeps. During that the e-Tag will turn on/off with an ascending/descending melody. Do not release the button. The e-Tag is now ready to pair again!

Under "My Devices", tap on the information icon next to "e-Tag".

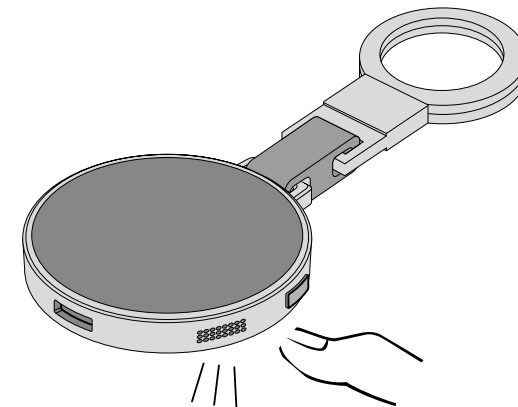
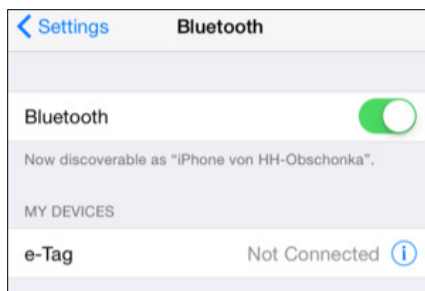

B. Montblanc e-Tag app

The Montblanc e-Tag app manages the connection between your e-Tag and phone. To set up the e-Tag app follow the "Getting Started" chapter at the beginning of this manual.

Overview

Once you have connected the e-Tag to your iPhone and launched the application, you will be forwarded to the connection screen. After the connection process is completed you will be prompted to the home screen. Please keep the application running in the background for best operation.

Connecting your e-Tag

The application will ask you to charge and then switch the e-Tag on by pressing its button for three seconds. The application will guide you through the pairing and connection process.



After the connection between your smartphone and your e-Tag is set up you can either choose between a preselected item you want to attach your e-Tag to (1) or enter a custom name.



Home screen

All functionalities of the application can be accessed from the home screen.

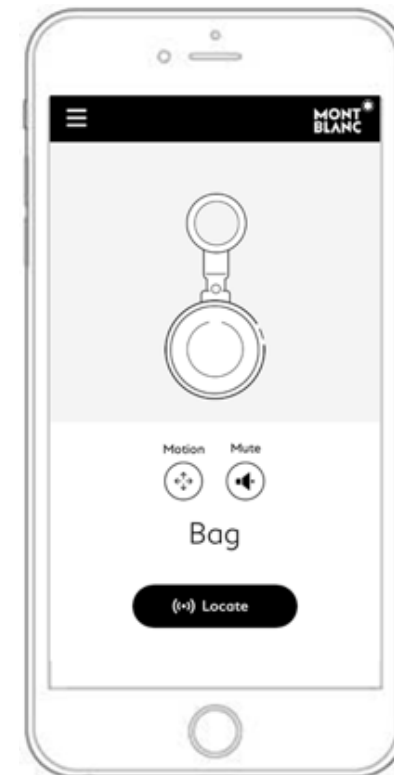

1. Locate your e-Tag
2. Motion alarm
3. Turn alarm on/off
4. Settings

1. Locate your e-Tag

Use the "Locate" function to find your e-Tag within your proximity. Tap on the locate button on the home screen and the e-Tag will play a melody to reveal its position.



Once you have found your device you can turn the alarm off by tapping on the "Done" button or pressing the button on the e-Tag.

2. Motion alarm

The motion alarm will react to any movement of the e-Tag and send an alert to your smartphone. To activate the alarm please tap on the "Motion" symbol on the home screen. For longer battery lifetime turn the motion alarm off when you don't need it.

3. Turn alarm on/off

To turn all alarms on/off tap on the "Mute" symbol on the home screen. If the symbol is black, alarms are turned off. It is recommended to only turn the alarm off in safe areas. There is no protection for your items if the alarm is turned off!

4. Settings

You can access the settings menu from the home screen by swiping from left to right or tapping on the three bars. The settings enable you to add safe zones (1) and display the connection status of your e-Tag (2). You can find additional information and support for your e-Tag in the lower part of the screen (3).

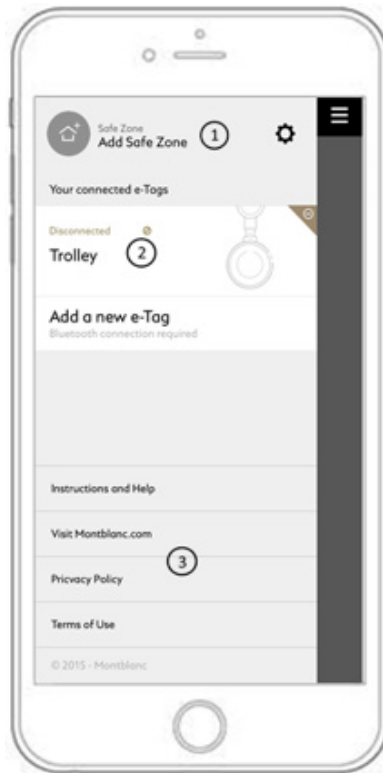

The last location of your e-Tag will be shown in the map. Tap on the “Get directions” button and the route to the last location of the device before it got out of range will be calculated.

Last location

When your e-Tag gets out of range you can tap on the “Last Location” button to see the last area your e-Tag was located in. The last location is the area where the e-Tag lost the connection to your phone.

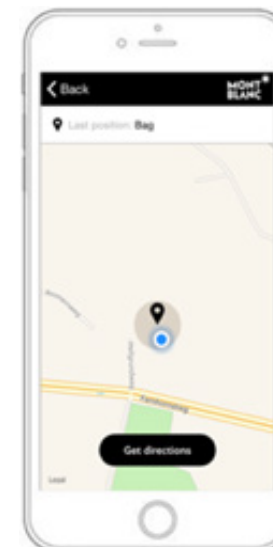

Reconnection notification

When your e-Tag gets back into range after losing connection it sends a notification to your iPhone to inform you that it reconnected.

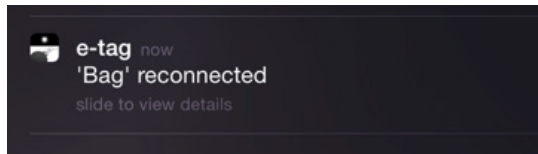

This feature is useful for example to track the arrival of your luggage on the carousel!

Managing your e-Tag connections

You can check the status of your e-Tag connections under "Your connected e-Tags".

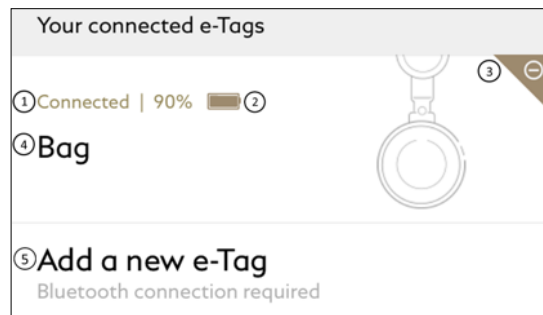

1. Connection status: shows "Connected" when the e-Tag is tethered to your iPhone or "Disconnected" when it is not connected.
2. Battery status: shows the current power level of the e-Tag as a percentage. Please charge when this falls below 10%.
3. Change connection: tap on the "-" sign in order to disconnect the e-Tag.
4. Name: displays the name of your e-Tag.
5. Add a new e-Tag: adds an e-Tag to your iPhone. The number of e-Tags that can be connected to the application is limited to two.

Safe zones and further settings

You can add safe zones to avoid false alarms in secure areas. A safe zone can be any safe location like your home or your office. To add a safe zone tap on the house symbol in the settings (1) and enter the address of your safe zone. Please make sure that GPS is turned on during this process.

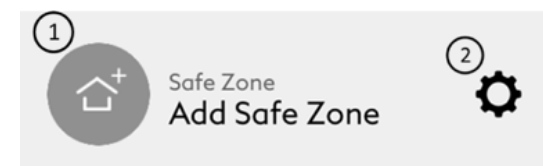

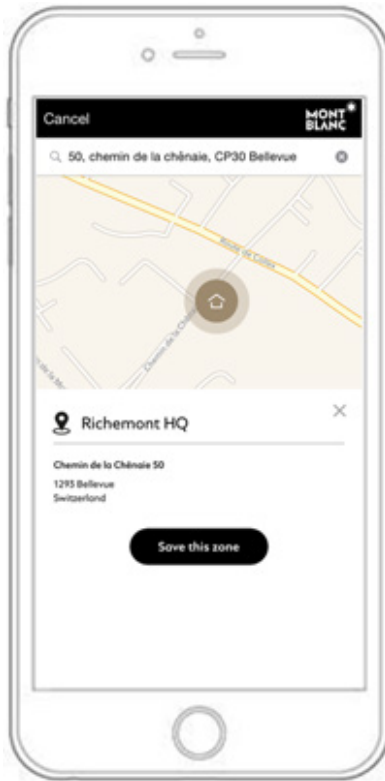

To adjust settings tap on the gearwheel (2). A menu will open up and you can decide whether to turn on/off the following options:

Notifications If turned off, the app will stop pushing notifications to the iPhone home screen when an alarm occurs or the e-Tag moves again into your range.

Sound If turned off, the phone will not play sounds on alarms.

Vibration

If turned off, the phone will not vibrate on alarms.

Bluetooth

Disables Bluetooth in the app and disconnects all e-Tags.

Alert in silent mode

If turned on, the app plays sounds on alarms even when the phone is muted.

Battery saving mode

If turned on, battery is saved at the expense of a less sensitive alarm detection.

C. Safety instructions

Please read the following warning and safety information carefully to prevent incidents. Any configuration or use other than what is in line with the suggested and intended use is not covered or guaranteed.

- Keep the e-Tag away from any ear, as hearing damage may occur.
- Montblanc does not guarantee against loss of possessions or people. Using the e-Tag in the correct and intended way might prevent loss of possessions.
- Do not disassemble, repair, modify, open, drop, puncture, crush, shred or try otherwise to damage the e-Tag. Refrain from putting high pressure on it or placing it near or in a heat source. The e-Tag should be used in temperatures between 32–95°F (0–35°C).
- Do not service the e-Tag yourself. For service and maintenance, contact a Montblanc Boutique or an authorised Montblanc Retailer.
- The e-Tag comes with a rechargeable lithium-ion battery which is flammable. Keep away from open flame. If the battery inside the e-Tag leaks, discontinue use, and do not allow the e-Tag to come in contact with your skin or eyes. In the event of accidental contact wash the affected area with large amounts of water and seek medical assistance immediately.
- Do not leave the e-Tag on prolonged charge when not in use. Damage resulting from the usage of an improper charger are not covered by the warranty.
- Please refrain from using the e-Tag while operating a vehicle as it may distract you.
- Only use the micro-USB cable provided for charging the e-Tag and take care to use a stable power source for charging.
- Keep your e-Tag dry, and do not use it with wet hands. Do not store your e-Tag in elevated temperatures or in high humidity. Moisture in or on the e-Tag may lead to electric shock.
- The e-Tag is not a toy. Keep the e-Tag and accessories away from small children.

D. Certification statements

FCC

This device complies with Part 15 of the FCC Rules. Operation is subject to the following two conditions:

1. this device may not cause harmful interference, and (2) this device must accept any interference received, including interference that may cause undesired operation.

Changes or modifications not expressly approved by the party responsible for compliance could void the user's authority to operate the equipment.



IC

This device complies with Industry Canada licence exempt RSS standard(s). Operation is subject to the following two conditions:

1. this device may not cause interference, and
2. this device must accept any interference, including interference that may cause undesired operation of the device.

Le présent appareil est conforme aux CNR d'Industrie Canada applicables aux appareils radio exempts de licence. L'exploitation est autorisée aux deux conditions suivantes:

1. l'appareil ne doit pas produire de brouillage, et
2. l'utilisateur de l'appareil doit accepter tout brouillage

IC ID: 20163-MB150911

IDA

Registration Number: N3079-15



Qualified Design ID: 72538

Disposal

If you wish to discard this product please contact your local authorities or dealer and ask for the correct method of disposal. Penalties may be applicable for incorrect disposal of this waste, in accordance with your national legislation.



E. End user licence agreement

About Montblanc and this End User Licence Agreement

Montblanc-Simplo GmbH has its registered offices at Hellgrundweg 100, D-22525 Hamburg. In this Device EULA, we use the term Montblanc (and "we", "us" and "our") to refer to the head office of Montblanc at the registered address above and to its affiliates.

This End User Licence Agreement ("Device EULA") is a legal agreement between you and Montblanc-Simplo GmbH for your use of the Montblanc e-Tag or other wearable technology (together the "Device"), including all associated media and online or electronic documentation. The Terms of Use also contain an end user licence agreement in respect of your use of the mobile application and forms part of the user documentation provided to you when you download the mobile application for the Device. Data is transferred from the Device to the mobile application and is encrypted over Bluetooth.

Please read the terms of this Device EULA carefully before using the Device. By using the Device, you signify your assent and agreement to this Device EULA. If you do not agree to this Device EULA, then you are not authorised to continue use of the Device.

Changes to this Device EULA

We may make changes to this Device EULA from time to time. If you do

not agree with the Device EULA at any time, you should cease using the Device. Your continued use of the Device constitutes your continued agreement with the current Device EULA.

Intellectual property and end user licence

You acknowledge that all intellectual property rights in the Device anywhere in the world belong to us or our licensors, that rights in the firmware that forms part of the Device are licenced (not sold) to you, and that you have no rights in, or to, the Device other than the right to use it in accordance with the terms of this Device EULA.

The design, trademarks, service marks, logos and branding displayed in the Device and all content and information within it, belongs to Montblanc and its licensors, and are protected by intellectual property legislation such as copyright, designs and trademark legislation and under international treaty provisions and national laws worldwide and you must not use it except as strictly permitted by this Device EULA.

In consideration of you agreeing to abide by this Device EULA, Montblanc grants you a limited, non-transferable, non-exclusive licence use of the Device and its firmware for your own non-commercial, educational, private or domestic use only. We reserve all other rights not expressly granted to you under this Device EULA.

You may not:

- a. rent, lease, sell, sublicense, redistribute, adapt, vary or modify the Device;
- b. copy, reverse engineer, decompile, attempt (in whole or in part) to obtain the source code of, modify or create derivative works of the Device, or any updates except to the extent that you cannot be prohibited from so doing under applicable law; or
- c. adapt or circumvent or disable any technological protection measures contained in or used to protect the Device.

You must not transmit any data, send or upload any material that contains viruses, Trojan horses, worms, time-bombs, keystroke loggers, spyware, adware or any other harmful programs or similar computer code designed to adversely affect the operation of any computer software.

Disclaimers and limitation of liability

This section applies to the Device only and not other Montblanc products. Nothing in this section is intended to limit any of your rights pursuant to the Montblanc International Guarantee provided to you with the Device. Montblanc hopes to provide helpful and accurate information on the Device, but makes no endorsement, representation or warranty of any

kind about any information, services or recommendations made available through the Device. All information, services or recommendations is provided for informational purposes only. Montblanc is not responsible for the accuracy, completeness, reliability, effectiveness, or correct use of information displayed or accessed through the Device. If you rely on any information provided by Montblanc or available through the Device, then this is at your own risk. In addition, Montblanc does not warrant or represent that the use of the Device will not infringe rights of third parties.

Access and information transmitted in connection with the Device will pass over public telecommunications networks. We make no representation or warranty in connection with, and disclaim any liability for, the network or service used to access and use the Device.

Montblanc does not warrant that the functional and/or technical aspects of the Device will be error-free or that the Device is free of viruses or other harmful components. If use of the Device results in the need for servicing or replacing property, material, equipment, data or other element, Montblanc is not responsible for those costs. Without limiting the foregoing, everything on the Device is provided to you "AS IS" AND "AS AVAILABLE" AND, TO THE FULLEST EXTENT PERMITTED BY APPLICABLE LAW, WITHOUT WARRANTY OF ANY KIND, EITHER EXPRESSED OR IMPLIED, INCLUDING, BUT NOT LIMITED TO, THE IMPLIED WARRANTIES OF MERCHANTABILITY, SATISFACTORY QUALITY, FITNESS FOR A PARTICULAR PURPOSE, REASONABLE CARE AND SKILL, OR NON-INFRINGEMENT. Montblanc and its suppliers or licensors make no warranties about the

(i) software, text, downloads, graphics, and links that form part of the Device, or about results to be obtained from using the Device; and (ii) the ability of the Device to integrate with any third-party software (including compatibility issues arising out of upgrades released for mobile operating systems).

Our maximum aggregate liability under or in connection with this Device EULA (including your use of the Device) and the Terms of Use whether in contract, tort (including negligence) or otherwise, shall in all circumstances be limited to the amount that you paid for the Device, provided that nothing in this Device EULA shall limit or exclude our liability for (i) death or personal injury resulting from our negligence, (ii) fraud or fraudulent misrepresentation, and (iii) any other liability that cannot be excluded or limited by law.

To the fullest extent permitted by applicable law, Montblanc shall not be liable for any indirect, incidental, special or consequential damages of any kind arising out of or in connection with the use of the Device (including reliance on information made available as part of your use of the Device) or any liability relating to any loss of use, interruption of business, lost profits or lost data, regardless of the form of action, whether in contract, tort (including negligence) or otherwise, even if Montblanc has been advised of the possibility of such damages.

Please note that in some jurisdictions consumer protection laws may not allow certain exclusions or limitation of warranties or liabilities, and consequently some of the above exclusions and limitations may not apply.

Termination and suspension

You agree that Montblanc may terminate or suspend your licence to use the Device at any time, with or without notice to you. We may terminate your licence if Montblanc reasonably believes that you have violated or acted inconsistently with the letter or spirit of the Device EULA, or violated the rights of Montblanc, its affiliated companies or any third party. You agree that Montblanc may modify or discontinue providing the Device, with or without notice to you. Upon termination of your licence you must stop using the Device.

Changes to the Device

You agree that Montblanc may change or update the Device and its features at any time. Depending on the update, you may not be able to use the Device until you have downloaded the latest version of it and accepted any new terms.

General provisions

If any provision, or part of a provision, of this Device EULA is found to be illegal, invalid or unenforceable, that provision or part-provision shall be deemed not to form part of this Device EULA, and the legality, validity or enforceability of the remainder of the provisions of this Device EULA shall not be affected, unless otherwise required by operation of applicable law.

This Device EULA, the Terms of Use and the Privacy Policy constitute the entire agreement between you and us in relation to the use of the Device, and replace and extinguish all prior agreements, draft agreements, arrangements, undertakings, or collateral contracts of any nature made by the parties, whether oral or written, in relation to such subject matter. The waiver by Montblanc of a breach of any provision of these Terms of Use will not operate to be interpreted as a waiver of any other or subsequent breach.

Applicable law and jurisdiction

This Device EULA shall be governed by and construed in accordance with the laws of Switzerland, without reference to conflict of laws provisions. Any dispute, controversy or claim arising out of or in relation to this Device EULA, including the validity, invalidity, breach or termination thereof, shall be adjudicated or arbitrated in accordance with this Device EULA. Where the laws of Switzerland are different to the mandatory consumer laws in your own country, we will afford you with similar protection.

F. Privacy policy

About Montblanc and this Privacy Policy

Montblanc-Simplo GmbH has its registered offices at Hellgrundweg 100, D-22525 Hamburg and acts as the data controller in connection with all personal information that is processed under this Privacy Policy. In this Privacy Policy, we use the term Montblanc (and "we", "us" and "our") to refer to the head office of Montblanc at the registered address above and its affiliates.

Please take a moment to read the following policy, which explains how the Montblanc e-Tag or other wearable technology and the associated mobile applications (together the "Device") collects, uses, discloses and transfers information provided to it through use.

You can find out more about terms governing the use of the Device in the Terms of Use (www.montblanc.com/e-tag).

Updates to this Privacy Policy

From time to time we may update this Privacy Policy. When we do we will publish the changes on this Platform.

Protecting your information

We want you to feel confident about using the Device, and we are committed to protecting the personal information that the Device collects. Accordingly, such information will be stored locally on the Device and can only be accessed on your device.

Contact us

If you have any questions or comments about this Privacy Policy, or privacy matters generally, please contact us at the address provided below. You can also use this address if you wish to request access to the personal data we hold about you.

service@montblanc.com

Montblanc-Simplo GmbH

Hellgrundweg 100

D-22525 Hamburg

Telephone: +49 40 84 001 0 / Telefax: +49 40 84 001 300

G. Terms of Use

About Montblanc and these Terms of Use

Montblanc-Simplo GmbH has its registered offices at Hellgrundweg 100, D-22525 Hamburg. In these Terms of Use, we use the term Montblanc (and "we", "us" and "our") to refer to the head office of Montblanc at the registered address above and its affiliates.

These Terms of Use represent a legal agreement between you and Montblanc Simplo GmbH governing your use of the Montblanc e-Tag or other wearable technology and the associated mobile application (together the "Device"), including all associated media and online or electronic documentation. The Device is operated by or on behalf of Montblanc-Simplo GmbH.

These Terms of Use also contain an end user licence agreement in respect of your use of the mobile application for the Device. The Device EULA governs the use of the Device itself and forms part of the user documentation provided to you with your device.

Please read these Terms of Use carefully before using the Device. Your use of the Device is governed by and subject to the terms of these Terms of Use. By downloading the mobile application and using the device, you signify your assent and agreement to these Terms of Use. If you do not

agree to these Terms of Use, then you are not authorised to continue use of the Device.

Updates to these Terms of Use

We may make changes from time to time to these Terms of Use so please check back regularly to stay informed of updates. The latest version of these Terms of Use will always be available on www.montblanc.com/e-tag. Any new version of these Terms of Use shall take effect and will govern the use of the Device and your relationship with us immediately upon the date of posting. By continuing to use the Device, you agree to be bound by the terms of these updates and amendments.

About our hosting services

Hosting Services for our website is provided by Richemont International SA at 1752 Villarssur Glâne, which is located in Switzerland. We do not host data as part of your use of the Device.

Mobile applications may be hosted by us or by other companies and you should refer to the relevant conditions of such other company.

Our privacy policy

Our information collection practices are governed by the terms of our Privacy Policy (www.montblanc.com/e-tag).

Your use of the Device

Full use of the Device requires compatible devices.

You agree to use the Device only for lawful purposes and only in compliance with (i) all applicable local, national and international laws and regulations connected with the Device, (ii) these Terms of Use and the Device EULA, and (iii) any reasonable instructions and guidelines that we may issue within the Device or otherwise in relation to the Device from time to time.

Intellectual property and end user licence for the mobile application

You acknowledge that all intellectual property rights in the mobile application anywhere in the world belong to us or our licensors, that rights in the software that forms part of the mobile application are licenced (not sold) to you, and that you have no rights in, or to, the mobile application other than the right to use each of them in accordance with these Terms of Use. In consideration of you agreeing to abide by these Terms of Use,

Montblanc grants you a limited, non-transferable, non-exclusive licence to install and use the mobile application on any supported mobile device for your own non-commercial, educational, private or domestic use only. Your download of the mobile application is subject to the terms of download imposed by the operator of the app store from which you download the mobile application. We reserve all other rights not expressly granted to you under these Terms of Use.

You may not:

- use the mobile application on any device that you do not own or control;
- rent, lease, sell, sublicense, redistribute, adapt, vary or modify the mobile application;
- copy, reverse engineer, decompile, attempt (in whole or in part) to obtain the source code of, modify or create derivative works of the mobile application, or any updates except to the extent that you can not be prohibited from so doing under applicable law; or
- adapt or circumvent or disable any technological protection measures contained in or used to protect the mobile application.

You must not transmit any data, send or upload any material that contains viruses, Trojan horses, worms, time-bombs, keystroke loggers, spyware, adware or any other harmful programs or similar computer code designed to adversely affect the operation of any computer software.

Use of materials on the Device

You may download one computer copy or print one copy of the material made available to you as part of your use of the Device, or download the application on to your mobile device, for your own non-commercial, educational, private or domestic use only, provided that proprietary notices, in particular intellectual property notices such as copyright© and trademark™, are preserved intact and are not modified, deleted or changed. Unless otherwise stated, you should assume that everything that you see or read on the Device (such as images, photographs, including any person represented in the photographs, illustrations, icons, texts, video clips, music, written and other materials) ("Montblanc Material") are protected by legislation such as copyright, designs and trademark legislation and under international treaty provisions and national laws worldwide.

You are not authorised to sell, reproduce, distribute, communicate, modify, display, publicly perform, report or otherwise prepare derivative or second-hand works based on or use any Montblanc Material in any way for any public or commercial purposes. Furthermore, Montblanc Material may not be displayed or communicated on any other platform, in a networked computer environment or on any other digital platform for any purpose whatsoever. In the event of breach of any of these Terms of Use, your permission to use the Montblanc Material will automatically terminate and any copies made of Montblanc Material must be immediately destroyed. Any unauthorised use of the Montblanc Material may infringe copyright laws, trademark laws, the laws of privacy and publicity, and communications regulations and statutes.

Disclaimers and limitation of liability

This section applies to the Device only and not other Montblanc products. Nothing in this section is intended to limit any of your rights pursuant to the Montblanc International Guarantee provided to you with the device. Montblanc hopes to provide helpful and accurate information on the Device, but makes no endorsement, representation or warranty of any kind about any information, services or recommendations made available through the Device. All information, services or recommendations is provided for informational purposes only. Montblanc is not responsible for the accuracy, completeness, reliability, effectiveness or correct use of information displayed or accessed through the Device. If you rely on any information provided by Montblanc or available through the Device, then this is at your own risk. In addition, Montblanc does not warrant or represent that the use of the Device and/or Montblanc Material will not infringe rights of third parties.

Access and information transmitted in connection with the Device will pass over public telecommunications networks. We make no representation or warranty in connection with, and disclaim any liability for, the network or service used to access and use the Device.

Montblanc does not warrant that the functional and/or technical aspects of the Device will be error-free or that the Device, Montblanc Material or the servers that make them available are free of viruses or other harmful components. If use of the Device or Montblanc Material results in the need for servicing or replacing property, material, equipment, data or

other element, Montblanc is not responsible for those costs. Without limiting the foregoing, everything on the Device is provided to you "AS IS" AND "AS AVAILABLE" AND, TO THE FULLEST EXTENT PERMITTED BY APPLICABLE LAW, WITHOUT WARRANTY OF ANY KIND, EITHER EXPRESSED OR IMPLIED, INCLUDING, BUT NOT LIMITED TO, THE IMPLIED WARRANTIES OF MERCHANTABILITY, SATISFACTORY QUALITY, FITNESS FOR A PARTICULAR PURPOSE, REASONABLE CARE AND SKILL, OR NON-INFRINGEMENT. Montblanc and its suppliers or licensors make no warranties about the (i) Montblanc Materials, software, text, downloads, graphics, and links of the Device, or about results to be obtained from using the Device; and (ii) the ability of the Device to integrate with any third-party software (including compatibility issues arising out of upgrades released for mobile operating systems).

Our maximum aggregate liability under or in connection with these Terms of Use (including your use of the mobile application) and the Device EULA whether in contract, tort (including negligence) or otherwise, shall in all circumstances be limited to the amount that you paid for the device, provided that nothing in these Terms of Use shall limit or exclude our liability for (i) death or personal injury resulting from our negligence, (ii) fraud or fraudulent misrepresentation, and (iii) any other liability that cannot be excluded or limited by law.

To the fullest extent permitted by applicable law, Montblanc shall not be liable for any indirect, incidental, special or consequential damages of any kind arising out of or in connection with the use of the Device (including

reliance on information made available as part of your use of the Device) or any liability relating to any loss of use, interruption of business, lost profits or lost data, regardless of the form of action, whether in contract, tort (including negligence) or otherwise, even if Montblanc has been advised of the possibility of such damages.

Please note that in some jurisdictions consumer protection laws may not allow certain exclusions or limitation of warranties or liabilities, and consequently some of the above exclusions and limitations may not apply.

Trademark notice

In general, all trademarks, logos and service marks that appear on the Device are registered, unregistered or otherwise protected Montblanc trademarks or are licenced for use by Montblanc by third parties. Other trademarks are proprietary marks and are registered to their respective owners. Nothing contained on the Device should be construed as granting, by implication or otherwise, any licence or right to use any trademark without Montblanc's prior written permission or that of such third party who owns the trademark. Misuse of any trademark displayed on the Device, or any other content on the Device, except as provided herein, is strictly prohibited.

Copyright notice

All content (including Montblanc Materials) on the Device are either Copyright © Montblanc or are licenced for use by Montblanc. All rights are reserved. Please refer to the section above on Use of Materials on the Device.

Links & linking

The Device may contain links to other platforms operated by third-parties not affiliated to Montblanc. The inclusion of any link to such third-party sites does not imply endorsement by Montblanc of those sites. Montblanc has not reviewed all of the content contained in the linked sites and is not responsible for the content or accuracy of any off-site pages or any other sites linked to any of the Device. If you choose to click through any link to off-site pages or third-party sites then this is at your own risk.

Termination and suspension

You agree that Montblanc may terminate or suspend your access to and use of the Device if Montblanc reasonably believes that you have violated or acted inconsistently with the letter or spirit of these Terms of Use, or violated the rights of Montblanc, its affiliated companies or any third party, with or without notice to you. You agree that Montblanc may modify or discontinue providing any use of the Device, with or without notice to

you. You agree that Montblanc will not be liable to you or any third party as a result of such modification or discontinuation. The provisions entitled "Disclaimers and Limitation of liability" and "General provisions" will survive termination of these Terms of Use.

General provisions

If any provision, or part of a provision, of these Terms of Use is found to be illegal, invalid or unenforceable, that provision or part-provision shall be deemed not to form part of these Terms of Use, and the legality, validity or enforceability of the remainder of the provisions of these Terms of Use shall not be affected, unless otherwise required by operation of applicable law.

These Terms of Use, the Privacy Policy and the End User Agreement for the device constitute the entire agreement between you and us in relation to the use of the Device, and replace and extinguish all prior agreements, draft agreements, arrangements, undertakings, or collateral contracts of any nature made by the parties, whether oral or written, in relation to such subject matter.

The waiver by Montblanc of a breach of any provision of these Terms of Use will not operate to be interpreted as a waiver of any other or subsequent breach.

Applicable law and jurisdiction

These Terms of Use shall be governed by and construed in accordance with the laws of Switzerland, without reference to conflict of laws provisions. Any dispute, controversy or claim arising out of or in relation to the Terms of Use, including the validity, invalidity, breach or termination thereof, shall be adjudicated or arbitrated in accordance with said Terms of Use. Where the laws of Switzerland are different to the mandatory consumer laws in your own country, we will afford you with similar protection.

Contact us

If you have any questions or comments about these Terms of Use, or matters generally, please contact us at the address provided below. You can also use this address if you wish to request a copy of the personal data we hold about you.

service@montblanc.com

Montblanc-Simplo GmbH

Hellgrundweg 100

D-22525 Hamburg

Telephone: +49 40 84 001 0

Telefax: +49 40 84 001 300

H. Technical information

Battery	Lithium-ion battery
Connectivity	Bluetooth® Low Energy
Sensor	Accelerometer
Functions	<ul style="list-style-type: none">• Locate function• Proximity alarm• Last seen• Motion alarm
Temperature	Operating temperature of 32-95°F (0-35°C)

I. Disclaimer

The Bluetooth® word mark and logos are registered trademarks owned by Bluetooth SIG, Inc. and any use of such marks by Montblanc-Simplo GmbH is under licence.

All trademarks mentioned are the properties of their respective owner. iPhone® is a trademark of Apple Inc., registered in the U.S. and other countries. App Store™ is a service mark of Apple Inc.

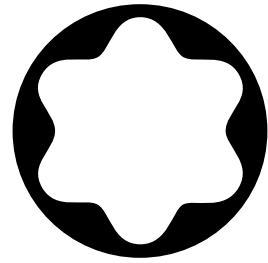

www.montblanc.com