

Service Manual and Parts List



29K71, 29K72 and 29K73

THE SINGER MANUFACTURING COMPANY

USE **SINGER**** OILS and LUBRICANTS

They insure freedom from lubricating trouble and give longer life to sewing equipment

The following are the correct lubricants for this machine:

TYPE B — MANUFACTURING MACHINE OIL, HEAVY GRADE

When an oil is desired which will produce a minimum of stain on fabrics, even after a long period of storage, use:

TYPE D — MANUFACTURING MACHINE OIL, HEAVY GRADE

OTHER **SINGER**** LUBRICANTS

TYPE E — THREAD LUBRICANT

For lubricating the needle thread of sewing machines for stitching fabrics or leather where a thread lubricant is required.

TYPE F — MOTOR OIL

For oil lubricated motors and plain bearings in power tables and transmitters.

NOTE: All of the above oils are available in 1 quart, 1 gallon and 5 gallon cans.

GEAR LUBRICANT

This specially prepared grease is recommended for gear lubrication on manufacturing sewing machines.

BALL BEARING LUBRICANT

This pure grease is specially designed for the lubrication of ball bearings and ball thrust bearings of motors and electric transmitters, ball bearing hangers of power tables, etc. Furnished in 1 lb. and 4 lb. tins.

SERVICE MANUAL
AND
PARTS LIST
FOR
SINGER**
29K71, 29K72 and 29K73
UNIVERSAL UPPER FEED MACHINES
SINGLE NEEDLE LOCK STITCH



THE SINGER MANUFACTURING COMPANY

Copyright © 1958 by The Singer Manufacturing Company

FOREWORD

This book contains complete information covering operation, adjustment, and parts list, for **Machines 29K71, 29K72 and 29K73**. Descriptions and exploded views of all parts assemblies on pages **17 to 44** inclusive, will be found helpful when ordering any part of the machine requiring renewal.

DESCRIPTION

Machines 29K71, 29K72 and 29K73, for stitching boots, shoes, and other tubular work in leather and fabrics, have the following characteristics:

Single Needle, Lock Stitch.

Stop Motion Hand Wheel—releases hand wheel from stitching mechanism for bobbin winding.

Horizontal Oscillating Shuttle.

Eccentric Adjustment for Shuttle Timing.

Cylinder Bed.

Replaceable Steel Horn.

Universal Upper Feed for Stitching in any direction without turning the work.

Stitch Length: 7 to 15 to the inch, depending on material being stitched and operations performed.

Presser Foot rise during feeding action: 1/4 inch — (Maximum clearance: 3/8 inch).

Double End Needle Plate — (two sizes of needle holes at each end for various sizes of needles).

Adjustable Thread Take-up Lever.

Two Speed Machine Pulley.

ACCESSORIES AVAILABLE UPON ORDER

(at additional charge)

Attachment for fitting Hand Wheel on front of machine (Part No. 82121).

Stand for mounting the machine $\left\{ \begin{array}{l} 601405 \text{ or } 601407 \text{ for foot power.} \\ 601406 \text{ or } 601408 \text{ for electric power.} \end{array} \right.$

Detachable Work Table for flat stitching operations (Part No. 83739, 83740, or 83741).

Electric Transmitter S-9.

SPECIAL FEATURES

MACHINE 29K71

End of cylinder bed is 1 inch wide and 7/8 inch deep.

Space at right of needle 12-1/4 inches.

Diameters of belt grooves 2-7/8 inches and 4-7/8 inches.

MACHINE 29K72

End of cylinder bed is 1-5/32 inches wide and 1-1/16 inches deep.

Space at right of needle 17-1/2 inches.

Diameters of belt grooves 3-1/4 inches and 5-1/2 inches.

Large Bobbin.

MACHINE 29K73

End of cylinder bed is 1 inch wide and 7/8 inch deep.

Space at right of needle 17-1/2 inches.

Diameters of belt grooves 3-1/4 inches and 5-1/2 inches.

SPEED

The maximum speed recommended for these machines is 500 stitches per minute, depending on material being stitched and operations performed.

For thick work, patching, mending, and stitching elastics, put the driving belt on the larger pulley of the machine and the smaller pulley of the stand.

For light work, put the belt on smaller pulley of the machine and the larger pulley of the stand.

When in operation, the hand wheel must always turn over toward the operator (counter-clockwise).

NOTE: If fitted on front of machine, hand wheel must always turn over toward the right (clockwise).

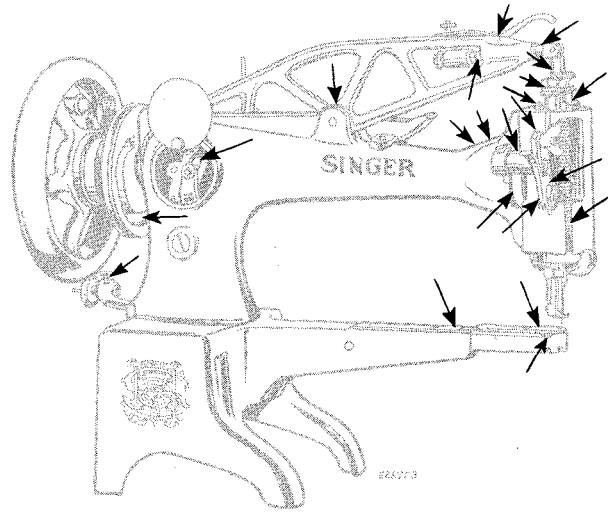

Fig. 3. Oiling Rear of Machine

TO OIL MACHINE

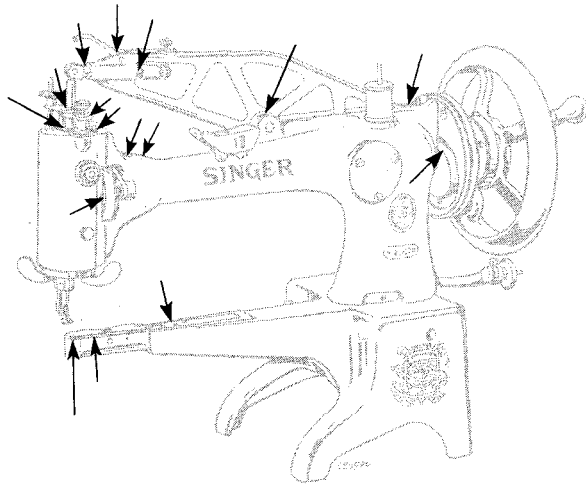

Fig. 2. Oiling Front Side of Machine

When machine is received from the factory, it should be thoroughly cleaned and a drop of oil should be applied to all parts indicated in Figs. 2, 3 and 4.

Apply a drop of oil to the stand at the centers upon which band wheel and treadle work. Also to both ends of the pitman rod connecting the treadle with band wheel.

Run machine for a few minutes to work oil into bearings. When the machine is in constant use, it should be oiled daily.

Use "TYPE B" or "TYPE D" OIL, sold by Singer Sewing Machine Company.

See inside front cover of this book for description of these oils.

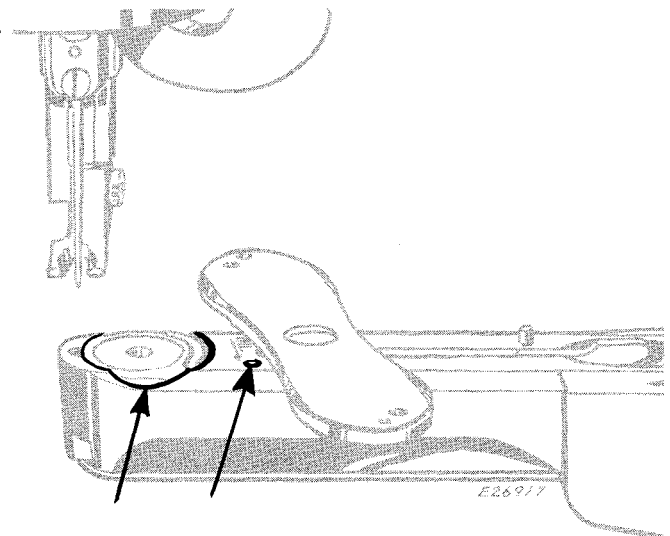

Fig. 4. Oiling Shuttle Race

To oil shuttle race, raise needle bar to its highest point and lift feeding foot A, Fig. 5 by moving lifter B upward.

Press down lever C, Fig. 5 and swing needle plate to position shown in Fig. 4.

Apply a drop of oil to the face of shuttle race and to the hole shown by arrow in Fig. 4.

TO OPERATE THE MACHINE

1. Raise feeding foot **A**, **Fig. 5** by moving lifter **B** upward.
2. Place both feet upon the treadle.
3. Turn top of hand wheel over toward you to start machine. (If hand wheel is fitted on front of machine, turn top of hand wheel from left to right to start machine.)
4. Allow the feet to move freely with the motion of the treadle. Continue this motion with an alternating pressure of heel and toe until a regular easy movement is acquired and the hand wheel is kept in continuous rotation by use of the feet alone.
5. When familiar with the treadle movement, and you are able to re-start the machine without turning the hand wheel in the wrong direction, place a piece of material under the feeding foot.
6. Lower feeding foot by lowering lifter and operate machine until you have become accustomed to guiding the material.

Material is moved along by the feeding foot only, and, the direction of stitching can be changed as desired, by turning wings, **Fig. 32**. To make a curved line of stitching, operate machine slowly and, without turning work, turn the revolving wings enough to produce the desired curve.

Feeding foot rises between each stitch while needle is in the material. With needle serving as pivot, material can be turned in any direction. When desired, the feeding foot may be fixed to work in a straight line, in any direction, by tightening the knurled screw **A**, **Fig. 22**.

Never turn the work or alter the direction of the feed while the foot is pressing on the material, as this may cause missed stitches and damage the surface of the work.

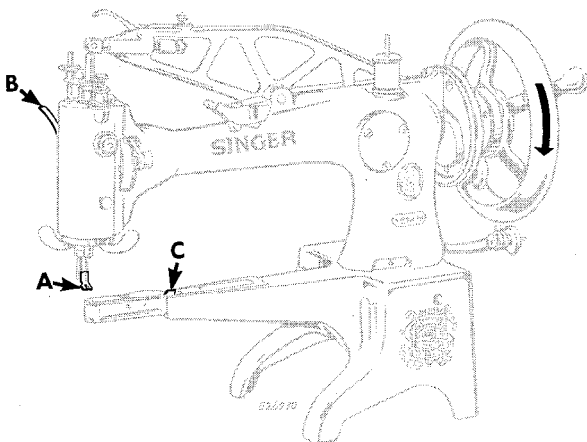

Fig. 5. Operating Machine

NEEDLES

Needles for **MACHINES 29K71, 29K72 and 29K73** are of Class and Variety 29 x 3 for cloth and 29 x 4 for leather. Needles 29 x 3 are made in sizes 11, 14, 16, 17, 18, 19, 21, 22, 23, 24 and 25, Needles 29 x 4 are made in sizes 9, 11, 14, 16, 18, 19, 21, 22, 23, 24 and 25.

The above needles regularly have nickel finish but can be supplied with chromium finish if ordered.

The size of the needle to be used should be determined by the size of the thread which must pass freely through the eye of the needle. Rough or uneven thread, or thread which passes with difficulty through the eye of the needle will interfere with the successful use of the machine.

Orders for needles must specify the **Quantity** required, the **Size** number, also the **Class** and **Variety** numbers separated by an x.

The following is an example of an intelligible order:

"100 No. 16, 29 x 3 Needles", for cloth.

"100 No. 16, 29 x 4 Needles", for leather.

The best stitching results will be obtained by using the needles sold by Singer Sewing Machine Company.

THREAD

Left twist thread should be used in the needle. Either right or left twist thread can be used for the bobbin.

To determine the twist, hold the thread as shown. Turn the thread over toward you between the thumb and forefinger of the right hand; if left twist, the strands will wind tighter. If right twist, the strands will unwind.

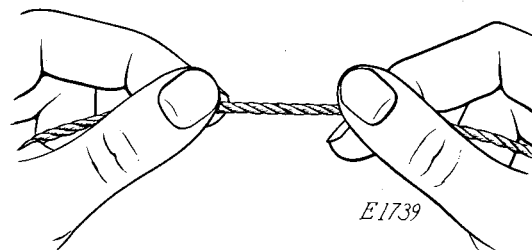

Fig. 6. Determining Twist of Thread

TO REMOVE THE BOBBIN

Raise needle bar to its highest point and lift feeding foot **A**, **Fig. 7** by moving lifter **B**, **Fig. 5** upward.

Press down lever **C**, **Fig. 7** and swing needle plate around as shown.

Turn hand wheel until point of shuttle is nearest operator, then lift out shuttle with thumb and forefinger.

Turn shuttle over and bobbin will drop out.

NOTE: For **29K72** machine, move bobbin retaining spring **D**, **Fig. 7** outward before taking out the bobbin.

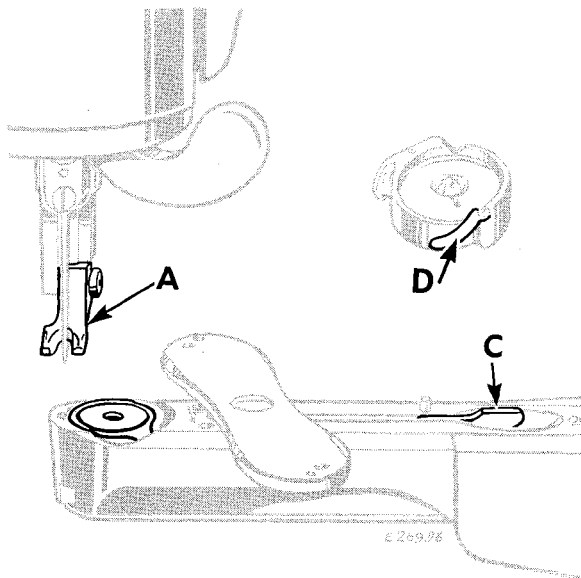

Fig. 7. Taking out the Shuttle

TO WIND THE BOBBIN

Disengage hand wheel from operating stitching mechanism by drawing out plunger **F**, **Fig. 8** and turning it slightly to left or right.

Place spool of thread on the spool pin and pass end of thread through the center slot or hole in the bobbin. Then press the bobbin, with slot in the side of the bobbin facing to the left, as far as it will go, on bobbin winder spindle.

Loosen thumb screw **D**, **Fig. 9** on bobbin winder and push it down until the rubber ring presses against the rim of the hand wheel, then tighten screw.

Turn hand wheel over toward you as when sewing and simultaneously guide the thread with the finger as shown in **Fig. 9**.

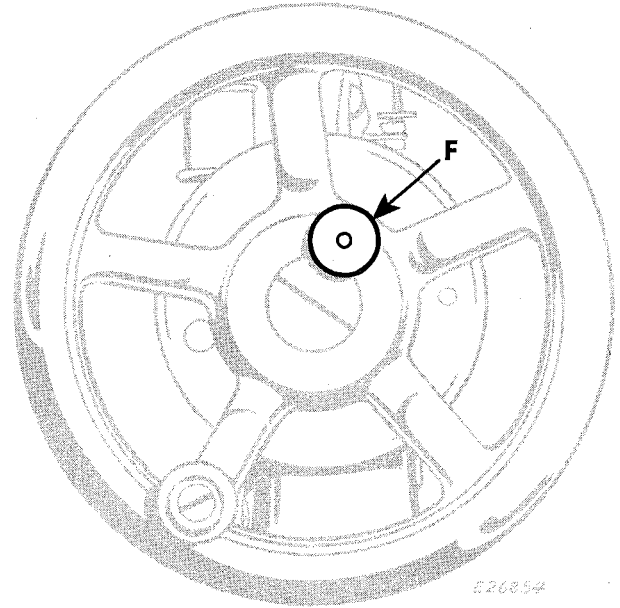

Fig. 8

NOTE: If hand wheel and bobbin winder are fitted on front of machine, the slot in the side of the bobbin must face to the outside. The top of hand wheel must then turn over to the right (clockwise) as when sewing to insure properly wound bobbins.

When bobbin is sufficiently full, remove it from the spindle. Loosen thumb screw **D**, **Fig. 9** on the winder and move screw upward in slot until the rubber ring is out of contact with the hand wheel, then tighten thumb screw.

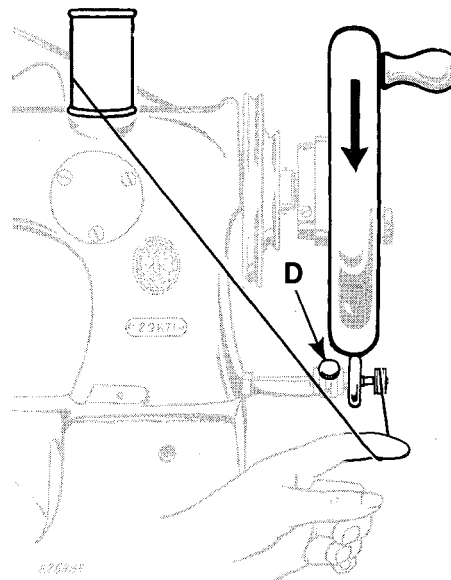

Fig. 9. Winding the Bobbin

Re-engage the hand wheel with the stitching mechanism by turning plunger **F**, **Fig. 8** slightly while simultaneously turning the hand wheel slowly until the plunger enters the hole in the inner disc.

TO THREAD THE SHUTTLE FOR 29K71 AND 29K73

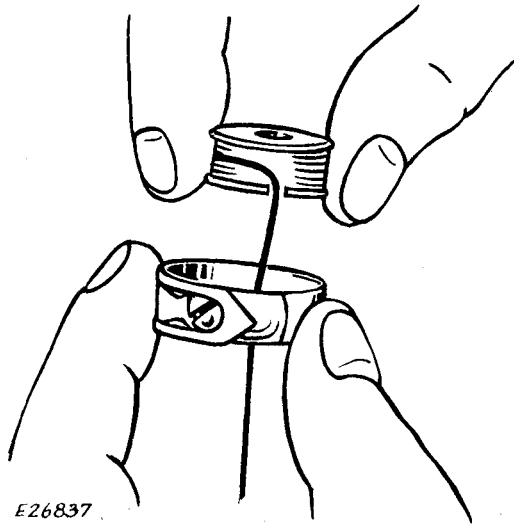

Fig. 10

Turn shuttle over while holding bobbin in it and draw the thread into the slot in the edge of the shuttle and under the end of the tension spring. See Fig. 11.

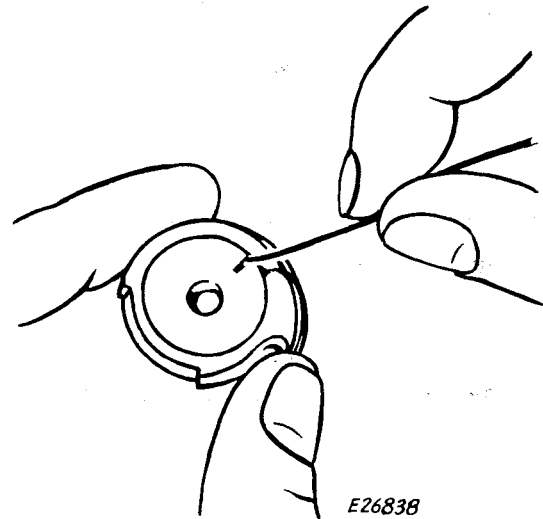

Fig. 11

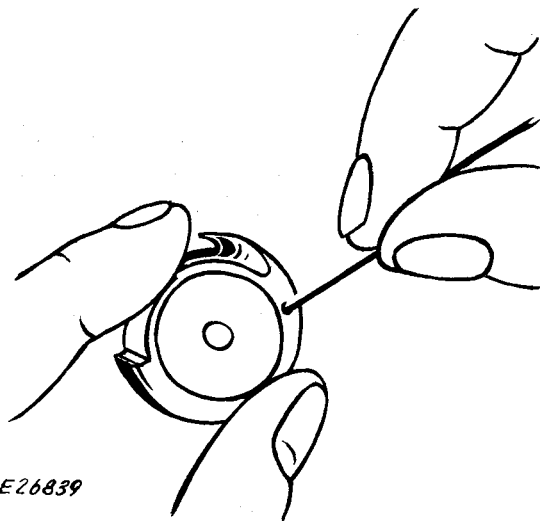

Fig. 12

Hold the bobbin between the thumb and forefinger of right hand, the slot in the edge of the bobbin being at the bottom. Allow two or three inches of thread to hang free.

Hold the shuttle in the left hand with the wide opening uppermost. Let end of thread pass through shuttle opening, then place bobbin into shuttle. See Fig. 10.

Pass the thread through delivery eye which is in the upper edge of the shuttle. See Fig. 12.

TO THREAD SHUTTLE FOR 29K72

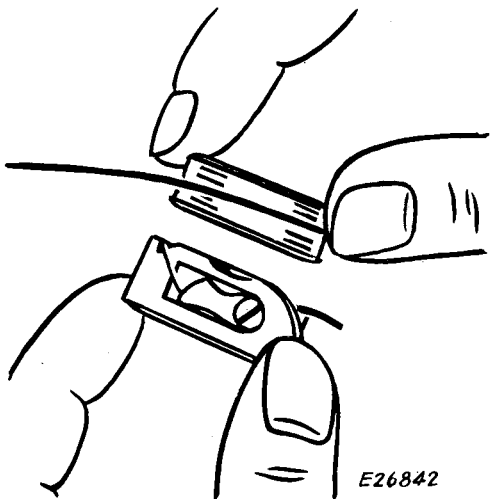

Fig. 13

Place bobbin into shuttle and push back the retaining spring which will hold the bobbin in the shuttle.

With the right hand, draw the thread into the slot in the edge of the shuttle as far as possible. See Fig. 14.

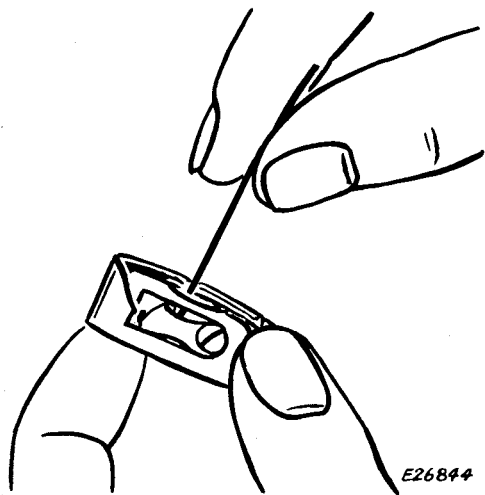

Fig. 15

Hold the bobbin between thumb and forefinger of right hand with the thread leading from right to left.

Hold the shuttle in the left hand with its open end up and its retaining spring moved outward. See Fig. 13.

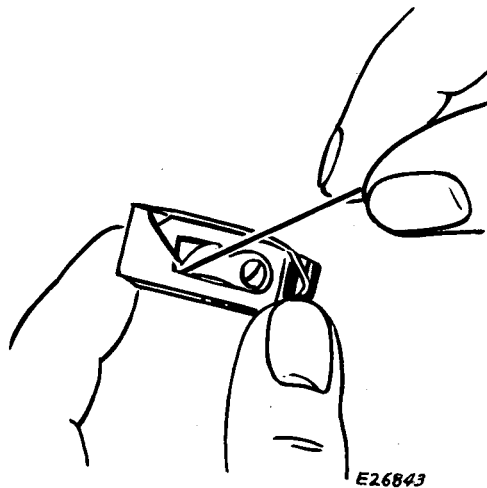

Fig. 14

Then draw thread to the left, up, and to the right under the spring. See Fig. 15.

Now insert end of thread up through the small hole in the edge of the shuttle and through the eye in top of the bobbin position post. See Fig. 16.

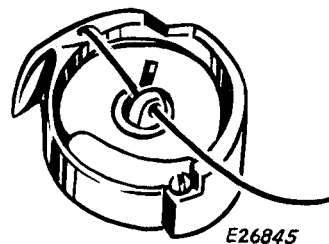

Fig. 16

TO REPLACE THE SHUTTLE

After threading the shuttle, turn hand wheel until the upright part of the shuttle carrier is to the right. Then with the point of the shuttle nearest you, and pointing towards the right, place it into the recess as shown in Fig. 17. With needle bar at its highest point, press down lever C, Fig. 17 and swing back needle plate to its sewing position.

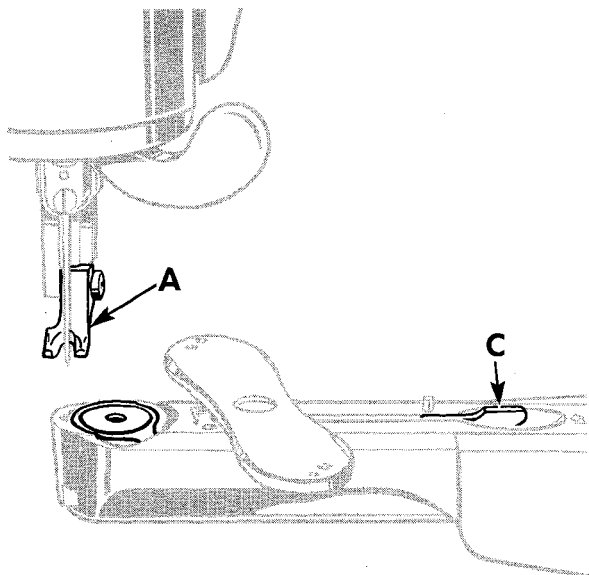

Fig. 17. Replacing Shuttle

TO SET THE NEEDLE

Raise needle bar to its highest point and loosen screw H, Fig. 18. Then insert shank of the needle up into the needle clamp as far as it will go with long groove of the needle to the left and its eye directly in line with the arm of the machine. Tighten screw H, Fig. 18. Loosen screw G, Fig. 18 and move the clamp to right or left until the needle passes through the center hole in the needle plate, then tighten screw G.

CAUTION: There are two double end needle plates furnished with each machine. Be certain needle is straight and corresponds to the correct needle hole size indicated on end of needle plate.

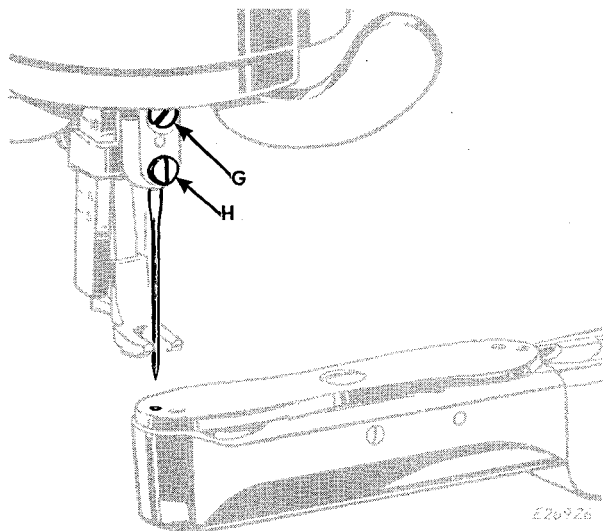

Fig. 18. Setting the Needle

TO THREAD NEEDLE

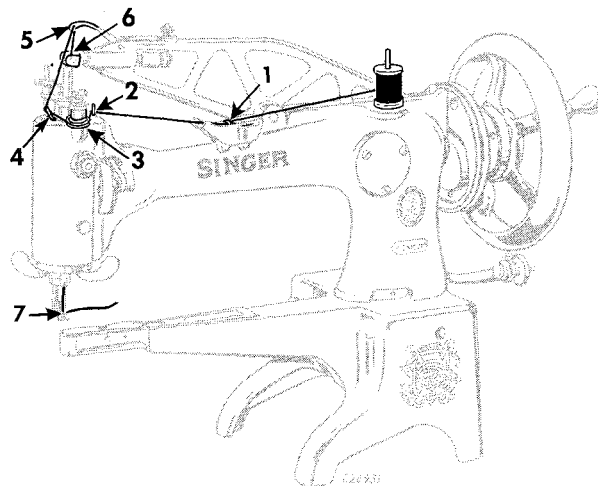

Fig. 19. Threading Needle

1. Place the spool of thread on the spool pin so that thread will draw from the rear side of spool. See Fig. 19.

2. Raise the wire guide in the oil cup on top of the arm and pass thread under guide 1, then press guide back into position.

3. Draw the thread around back of pin 2 which is near the tension discs on top of the arm and from back to front and right to left between the tension discs 3. See Fig. 20.

4. Pass thread through wire eyelet 4.

5. Lead thread up and from front to back through the hole 5 in the take-up lever.

6. Draw about 10 inches of thread through the hole in take-up lever and insert the end into the slit in the end of the threading wire supplied with the machine. Then pass end of threading wire down through hole 6 which runs through the center of the needle bar.

7. Remove thread from threading wire then withdraw threading wire. Pass the thread from left to right through the eye of the needle 7. Draw about three inches of thread through the eye of the needle with which to start sewing.

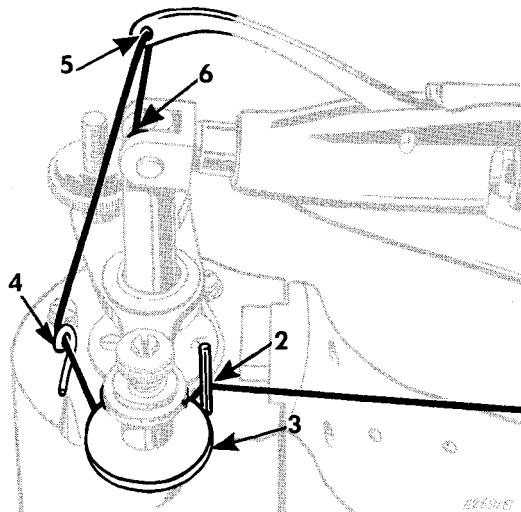

Fig. 20. Upper Threading

TO THREAD NEEDLE FOR DARNING

1. Place the spool of thread on the spool pin so that thread will draw from rear side of spool.
2. Raise the wire guide in the oil cup on top of the arm and pass thread under guide 1 then press guide back into position. See Fig. 19.
3. Pass thread over the pin 2 near the tension discs in front of the arm and from right to left under and between the tension discs 3, Fig. 21.
4. Pass thread through wire eyelet 4.
5. Pass thread up and from front to back through the hole 5 in the take-up lever.
6. Draw about 10 inches of thread through the hole in take-up lever and insert the end into the slit in the end of the threading wire supplied with the machine. Then pass end of threading wire down through hole 6 which runs through the center of the needle bar.
7. Remove thread from threading wire then withdraw threading wire. Pass the thread from left to right through the eye of the needle 7. Draw about three inches of thread through the eye of the needle with which to start darning.

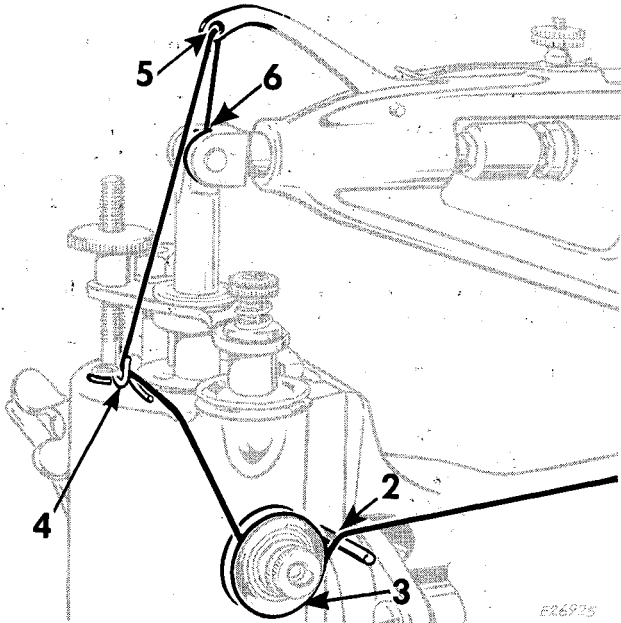

Fig. 21. Upper Threading for Darning

TO PREPARE FOR SEWING

With the left hand hold the end of the needle thread, leaving it slack from the hand to the needle. Turn top of hand wheel over toward you until the needle moves down and up again to its highest point, thus catching

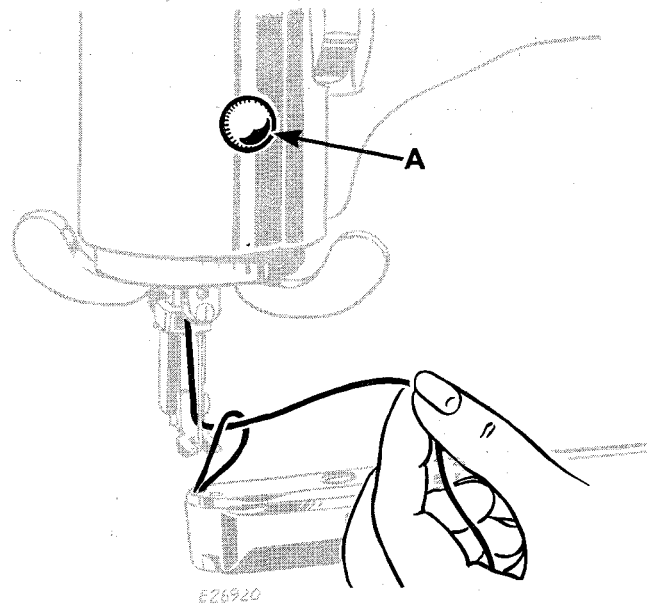

Fig. 22. Drawing up Bobbin Thread

the bobbin thread; draw up the needle thread and the bobbin thread will come up with it through the hole in the needle plate. See Fig. 22. Lay both threads back under the feeding foot.

NOTE: Turn top of hand wheel over toward the right (clockwise) if hand wheel is fitted on front of machine.

TO START SEWING

Place the material under the feeding foot, lower the foot and start to sew, turning the hand wheel over toward you. (Turn hand wheel to the right if located on front of machine.)

CAUTION: Do not try to help feeding of the work by pulling the material as this may deflect the needle and cause it to break. The machine feeds the work easily without any assistance.

TO REMOVE THE WORK

Let the needle bar rest at its highest point, raise the feeding foot, then draw the material backward about 3 inches and cut the threads close to the work. Leave the ends of the threads under the feeding foot.

TENSIONS

For perfect stitching, the tension on needle and bobbin threads must be heavy enough to pull threads to center of material and make a firm stitch, thus:



Fig. 23. Perfect Stitch

If the tension on the needle thread is too tight, or if that on the bobbin thread is too loose, the needle thread will lie straight along the upper surface of the material thus:

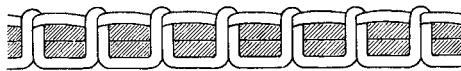

Fig. 24. Tight Needle Thread Tension

If the tension on the bobbin thread is too tight, or if that on the needle thread is too loose, the bobbin thread will lie straight along the under side of the material, thus:

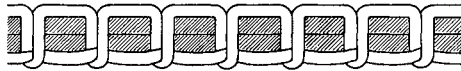

Fig. 25. Loose Needle Thread Tension

NEEDLE THREAD TENSION

The tension on the needle thread is regulated by the thumb nut near the tension discs. See Fig. 26.

To increase the needle thread tension, tighten thumb nut.

To decrease the needle thread tension, loosen thumb nut.

NOTE: Tension on needle thread can be tested only when the feeding foot is down.

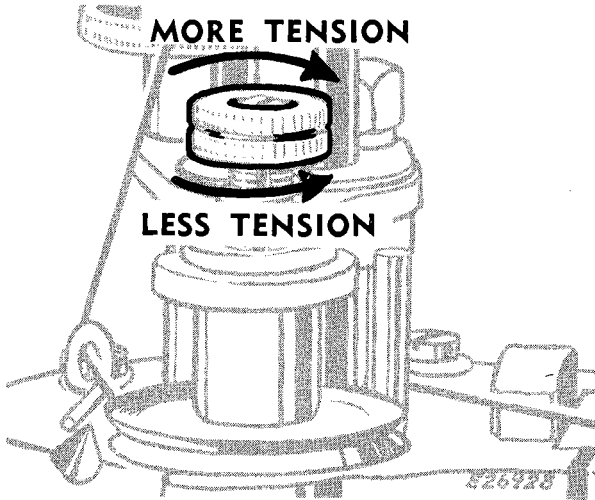

Fig. 26. Regulating Needle Thread Tension

BOBBIN THREAD TENSION

The tension on bobbin thread is regulated by the screw in Figs. 27 and 28 on the end of the shuttle tension spring.

To increase bobbin thread tension, gradually tighten screw. See Fig. 27.

To decrease bobbin thread tension, gradually loosen screw. See Fig. 28.

When bobbin thread tension has been properly adjusted, it is seldom necessary to change it because a correct stitch can be usually obtained by varying the needle thread tension.

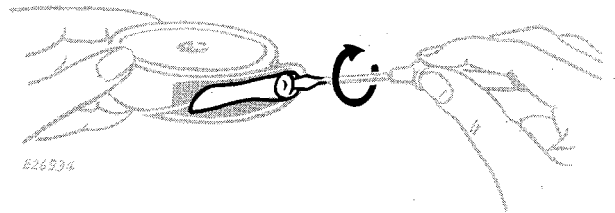

Fig. 27. Increasing Bobbin Thread Tension

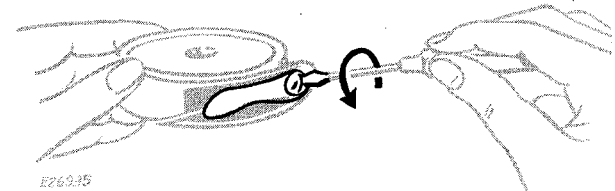

Fig. 28. Decreasing Bobbin Thread Tension

TO REGULATE THE TAKE-UP LEVER WITH REGULATOR INDICATOR

The spring tension on take-up lever **J**, Fig. 29 is adjusted by thumb nut **K**. The tension on this lever should be about the same as that applied to the upper thread by the tension discs.

When the stitch is set, at the top of the needle bar stroke, lever **J** should be held down far enough by the tension of the thread so that the take-up action will keep the thread taut until the needle enters the work.

When sewing light weight materials with fine thread, more take-up action may be secured by turning the thumb nut **K** so that it screws up to decrease the take-up spring tension. This should be done instead of tightening the thumb nut of the tension discs.

For heavier materials and thread, the take-up tension must be about the same as that applied to the upper thread by the tension discs.

The travel of take-up lever **J** is regulated by means of knurled nut **L**. The indicator near nut **L** is marked with the figures 0 to 4. This indicator provides a useful guide to the operator in setting the take-up movement most suitable for the material and thread being used. For thin materials, such as kid or box calf, turn knurled nut **L** until the zero mark is opposite the small plunger **U**.

Other adjustments can be made in steps by turning the nut to suit any thickness of material and thread within the capacity of the machine.

NOTE: All machines sent out from the factory are so adjusted that they will give satisfactory results on a general range of materials. Before any adjustment is made to the travel of the take-up lever, the needle bar should be raised to its highest point.

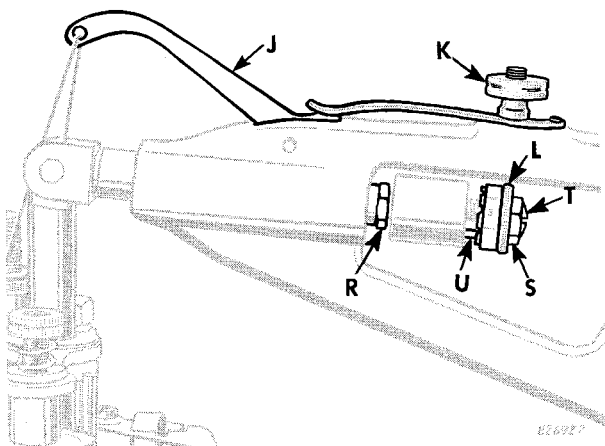

Fig. 29. Regulating Tension and Travel of Take-up Lever

ADJUSTMENT OF THREAD TAKE-UP LEVER REGULATOR INDICATOR

The range of adjustment given by the indicator, when sent out from the factory, should suffice for all general purposes, but, if desired, the range can be raised or lowered by means of the adjusting screw **T**, Fig. 29 at the extreme right.

To alter the range, loosen the lock nut **S** and, using a screwdriver, turn the center screw **T** to the right to reduce the travel of the take-up lever.

To increase the travel, turn the screw **T** to the left. Wear at the tip of the center screw can also be taken up in this manner. When the proper adjustment has been obtained, tighten the lock nut **S**.

It is most important that the hexagon head nut **R** be securely locked against the face of the piston.

TO CHANGE LENGTH OF STITCH

The length of stitch is regulated by the stitch regulator which is held in position by thumb screw **M**, Fig. 30 at back of the feeding foot bar. Loosen thumb screw **M** and move the regulator up or down until its top is in line with the mark indicating desired number of stitches to the inch as shown by the arrow. Then tighten the thumb screw.

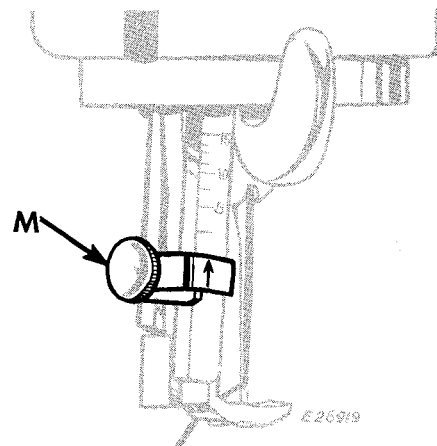

Fig. 30. Changing Stitch Length

TO REGULATE PRESSURE ON THE MATERIAL

The pressure on the material is regulated by knurled thumb nut **O**, Fig. 31. To increase the pressure, tighten the thumb nut. To reduce the pressure, loosen the thumb nut.

Heavier pressure is required for leather work than for sewing cloth or cotton materials. The pressure should be only heavy enough to enable the feed to move the work along evenly.

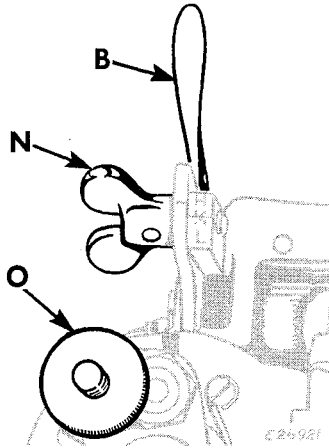

Fig. 31. Regulating Pressure on Material

TO TURN A CORNER

Stop the machine with the needle in the work and turn top of hand wheel over toward you until the feeding foot rises. Then turn the work as desired, using the needle as a pivot.

NOTE: If hand wheel is located on front of machine, turn top of hand wheel over to the right.

TO REGULATE THE AUTOMATIC LIFT OF THE FEEDING FOOT

While the machine is in operation, the feeding foot rises after it has moved the work forward; then the foot moves toward the needle and descends again upon the fabric. It is advisable that the lift of the foot should be only sufficient to clear the thickest part of the work.

To adjust the lift, raise the feeding foot by means of lifter **B**, Fig. 31. To increase the feeding foot lift, loosen wing screw **N** and move the screw toward you. To reduce the lift, move the screw away from you. When the desired height of lift is obtained, tighten the wing screw.

TO CHANGE DIRECTION OF THE FEED

While stitching, the work is moved along by the action of the feeding foot only.

The direction of the stitching can be changed as desired by turning the foot around by means of the two handles **E**, Fig. 32.

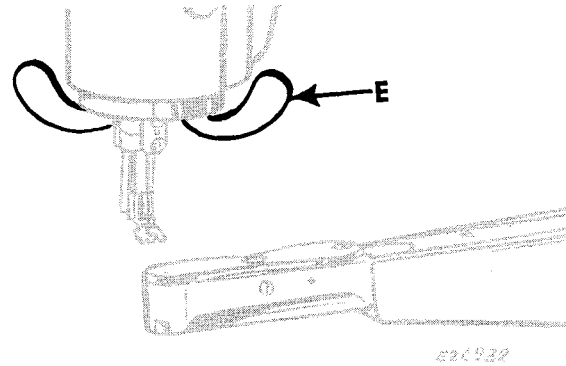

Fig. 32. Changing Feed Direction

TO CHANGE THE NEEDLE PLATE

1. Raise the needle bar to its highest position.
2. Loosen screw **Q**, Fig. 33 and, by lifting upward, remove needle plate and hinge pin **P**.
3. When replacing the needle plate, place flat side of pin **P** toward screw **Q**.
4. Tighten screw **Q** on flat side of pin **P**.

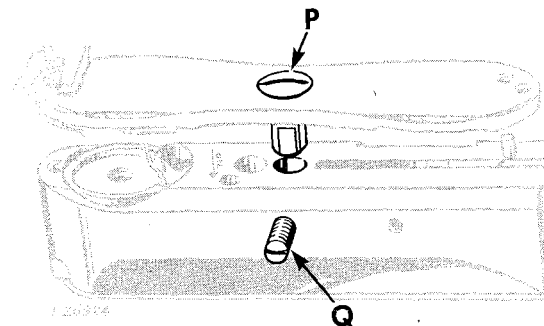

Fig. 33. Correct Position of Hinge Pin in Needle Plate

HINTS FOR PERFECT OPERATION

Oil the machine regularly.

The top of hand wheel must always turn over toward the operator (counterclockwise).

If located at side of machine, the hand wheel must turn over from left toward right (clockwise).

Never run the machine without material between the feeding foot and needle plate.

Do not run the machine when both shuttle and needle are threaded unless there is material under the feeding foot.

The Belt

See that the belt is not too tight; it should be just tight enough not to slip. If too loose, remove the hook at one end, shorten the belt and rejoin.

Machine Working Heavily

If the machine runs hard after standing idle for some time, use a little kerosene or benzine in the oiling places, run the machine rapidly, then wipe clean and oil.

To Avoid Breaking Needles

The feeding foot should be securely fastened by the thumb screw. Do not sew heavy seams or very thick material with too fine a needle. A large needle and thread to correspond should be used on heavy work.

See page 5.

Avoid pulling the material when stitching. This may cause the needle to strike on the needle plate and break.

Breaking of Upper Thread

Improper threading of machine.

Tension being too tight.

The thread being too coarse for the size of the needle.

The needle being bent, having a blunt point, or being set incorrectly.

Breaking of Under Thread

Improper threading of shuttle.

Bobbin Thread tension being too tight.

Skipping of Stitches

The needle may not be accurately set into the needle bar or the needle may be blunt or bent.

Remove the accumulation of dirt or lint which might gather behind thread retaining spring near bottom of needle bar by working a piece of tape or thread back and forth between spring and needle bar.

CAUTION: Do not bend spring away from needle bar or spring may become permanently damaged.

Examine feeding foot and remove any dirt or lint from the teeth to insure regular feeding of material.

Working on old, hard leather

When working on old, hard leather, it is advisable to soften the leather with oil, use a coarse needle and make a long stitch to prevent needle from splitting the leather.

TO EXAMINE, REMOVE AND RE-ASSEMBLE THE PARTS FROM THE RACK BOX

Remove machine from treadle stand or power bench after taking out the four screws located at the base of the machine. The machine should then be tilted back upon its machine pulley end, the underside facing the adjuster. Parts can be examined or removed from the rack box after taking out the two screws **V**, **Fig. 34** and removing the cover plate. The following parts are then exposed as shown in **Fig. 35**: long rack **Y**, short rack **X**, intermediate pinion **Z**, shuttle driving pinion **W**, needle plate locating pin and spring **A2**, all of which can be removed without disconnecting the rack box from the machine.

To take out the shuttle carrier, remove the small set screw in the shuttle driving pinion **W** by inserting a small screwdriver through the groove at the side of the rack box as shown in **Fig. 35**. The shuttle carrier can then be pressed through the pinion. To remove the long rack **Y**, insert a screwdriver through hole as shown in **Fig. 36** and take out the screw **X2**. Before proceeding to withdraw the rack, remove the pinion **Z**, **Fig. 35** then grip the rack and draw it straight toward the pulley end of the machine. The short rack **X** and shuttle driving pinion **W** can be removed without difficulty. When replacing any one or re-assembling the whole of these parts, care must be taken to see that the gears and racks are correctly engaged, as shown in **Fig. 36**.

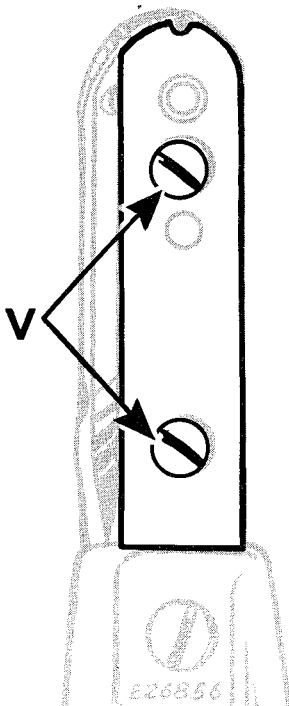

Fig. 34. Removing Cover Plate

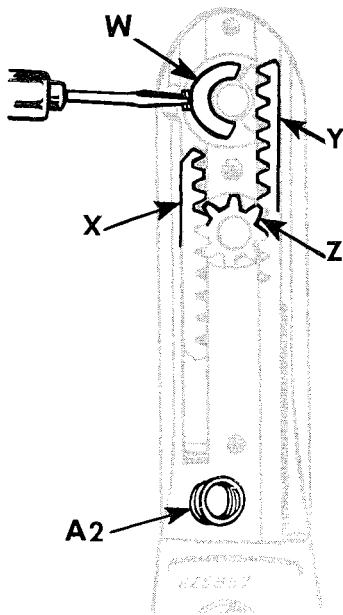

Fig. 35. Removing Parts from Rack Box

INSTRUCTIONS FOR REMOVAL OF THE RACK BOX

If for any reason it is necessary to remove the rack box from the machine, proceed as follows: Remove the machine from its treadle stand or power bench. Turn the hand wheel until the connecting rod hinge screw **X2**, **Fig. 36** is opposite the hole in the lower arm. Then tilt the machine back upon its machine pulley end, the underside facing the adjuster. Insert a screwdriver through the hole as shown in **Fig. 36**, and remove the screw **X2**. Slightly loosen the two screws **B2** by giving them a half turn with a screwdriver. Then drive out the taper pin **C2**, using a 3/16" punch and hammer, and take out the two screws **B2**. The machine should now be replaced on its feet and the horn will then come away if pulled in a horizontal direction.

CAUTION: Never raise the front of the horn or the end of the long rack may be damaged.

When re-assembling the box to the machine, be sure that the taper pin **C2** is driven in as far as it will go before finally tightening the two screws **B2**, **Fig. 36**.

NOTE: Cover plate is shown removed in **Fig. 36** to illustrate how the gears and racks should be correctly engaged.

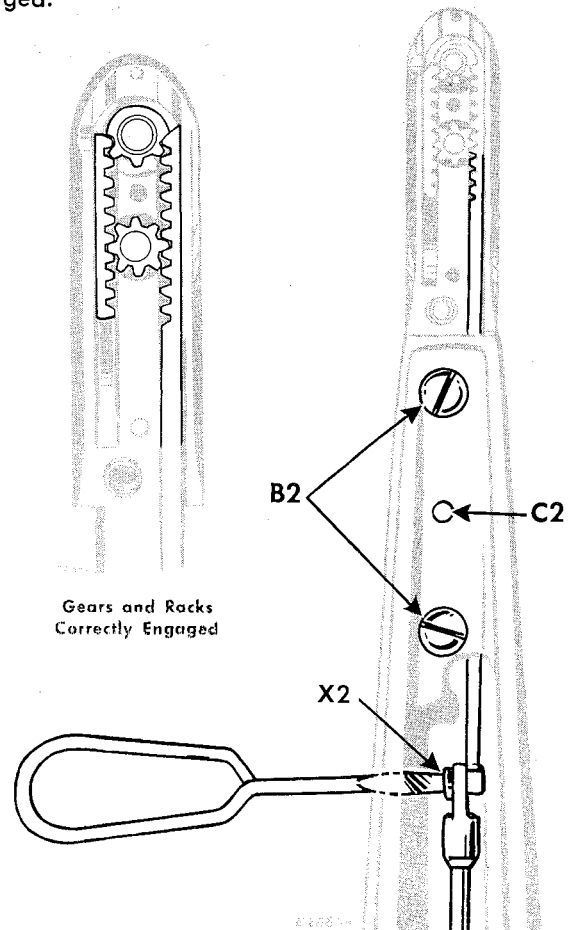

Fig. 36. Removing Rack Box

TO TIME THE SHUTTLE

Turn hand wheel until eccentric stud is aligned with screwdriver hole **D2**, **Fig. 37**.

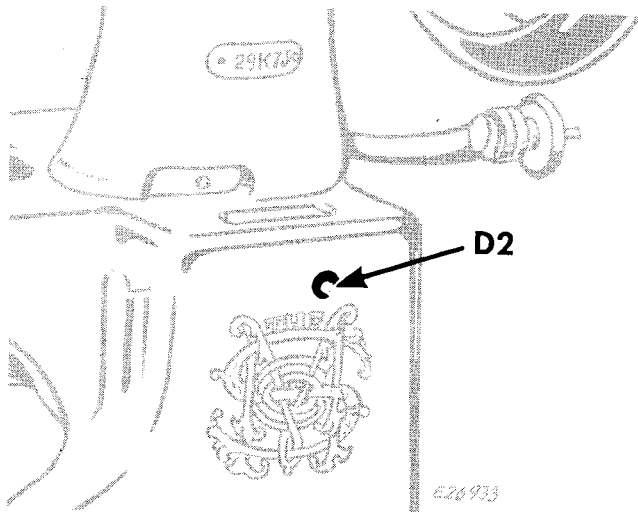

Fig. 37. Location of Eccentric Stud for Timing Shuttle

To time the shuttle, turn eccentric stud at hole **D2** until the leading edge of the shuttle carrier moves at each oscillation to a position approximately one-third the distance across the needle slot below the face plate as shown in **Fig. 38**.

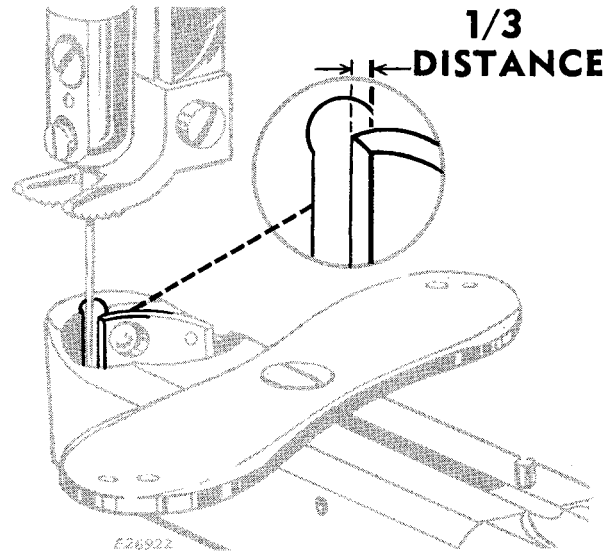

Fig. 38. Correct Timing of Shuttle Carrier

NOTE: Shuttle is removed in **Fig. 38** to illustrate correct timing of leading edge of shuttle carrier.

PARTS LIST

FOR

SINGER**

29K71, 29K72 and 29K73

SINGLE NEEDLE

LOCK STITCH

UNIVERSAL UPPER FEED MACHINES

THE SINGER MANUFACTURING COMPANY

PARTS LIST
FOR
MACHINES 29K71 TO 29K73

INSTRUCTIONS FOR ORDERING

To simplify ordering of parts, exploded views of the various sections of the mechanism are shown in the same illustration as the assembly of those parts. On the page opposite the illustration is a list of parts with key or reference numbers to indicate the position of that part in the illustration. These key numbers in the first column are for reference only and are not to be used in ordering parts.

In ordering from this list, use ONLY the PART number in the SECOND column.

The number stamped on a Sewing Machine Part is the number of the single part only.

Every combination of parts sent out has its specific number which, although not stamped on Parts must be used when ordering the combination.

Each number always indicates the SAME PART in whatever list it appears, or for whatever Machine.

The letters after some of the numbers indicate the style of finish only, as follows:

- AL Heat Treated for Toughness.
- C Hardened only.
- D Polished only.
- E Soft, Not polished.
- F Hardened and Polished.
- H Blued.
- J Nickel Plated only.
- K Hardened and Nickel Plated.
- R Phosphate Coating Formed on Surface of Iron or Steel.
- W Polished and Nickel Plated.

These letters MUST BE USED when they appear in the list and AFTER the number, as in the list.

Parts marked with an asterisk (*) are furnished only when repairs are made at the factory.

SHAFT, CAM WHEEL, SHUTTLE DRIVING LEVER, PULLEY WHEEL
AND SHUTTLE DRIVING LEVER CONNECTING ROD ASSEMBLY

Ref. No.	Part No.	Description
1	82122	Shuttle Driving Cam and Gear, Nos. 81872 and 82073
2	82010	Shaft (29K71 Machine)
	82011	Shaft (29K72 and 29K73 Machines)
3	3012	Pin
4	81872	Gear
5	82073	Shuttle Driving Cam with SS235C
6	SS235C	Screw
7	8661	Needle Bar Cam and Pulley Wheel with 361C (29K71 Machine)
	81941	Needle Bar Cam and Pulley Wheel with 361C (29K72 and 29K73 Machines)
8	82149	Feed Motion Cam Wheel with RR18 and 81868
9	11663	Cam Wheel Pin
10	RR18	Roller
11	4449	Shaft Bushing
12	81868	Roller Pin
13	1808	Roller and Stud
14	SS572C	Bearing Screw (29K71 Machine)
	SS575C	Bearing Screw (29K72, 29K73 Machines)
15	82184	Shuttle Driving Lever with 1808
16	1520R	Eccentric Stud Nut
17	361C	Cam and Pulley Wheel Set Screw
18	82233	Shuttle Driving Lever Connecting Rod complete, Nos. 8569, 8645, 82186, 82194 and 82232 (29K71 Machine)
	82237	Shuttle Driving Lever Connecting Rod complete, Nos. 8569, 8645, 82186, 82194 and 82236 (29K72 Machine)
	82239	Shuttle Driving Lever Connecting Rod complete, Nos. 8569, 8645, 82186, 82194 and 82238 (29K73 Machine)
19	82194	Connecting Rod End (front)
20	8645	Pin (front)
21	82232	Connecting Rod (29K71 Machine)
	82236	Connecting Rod (29K72 Machine)
	82238	Connecting Rod (29K73 Machine)
22	8569	Pin (back)
23	82186	Connecting Rod End (back)
24	SS573C	Eccentric Stud

SHAFT, CAM WHEEL, SHUTTLE DRIVING LEVER, PULLEY WHEEL
AND SHUTTLE DRIVING LEVER CONNECTING ROD ASSEMBLY

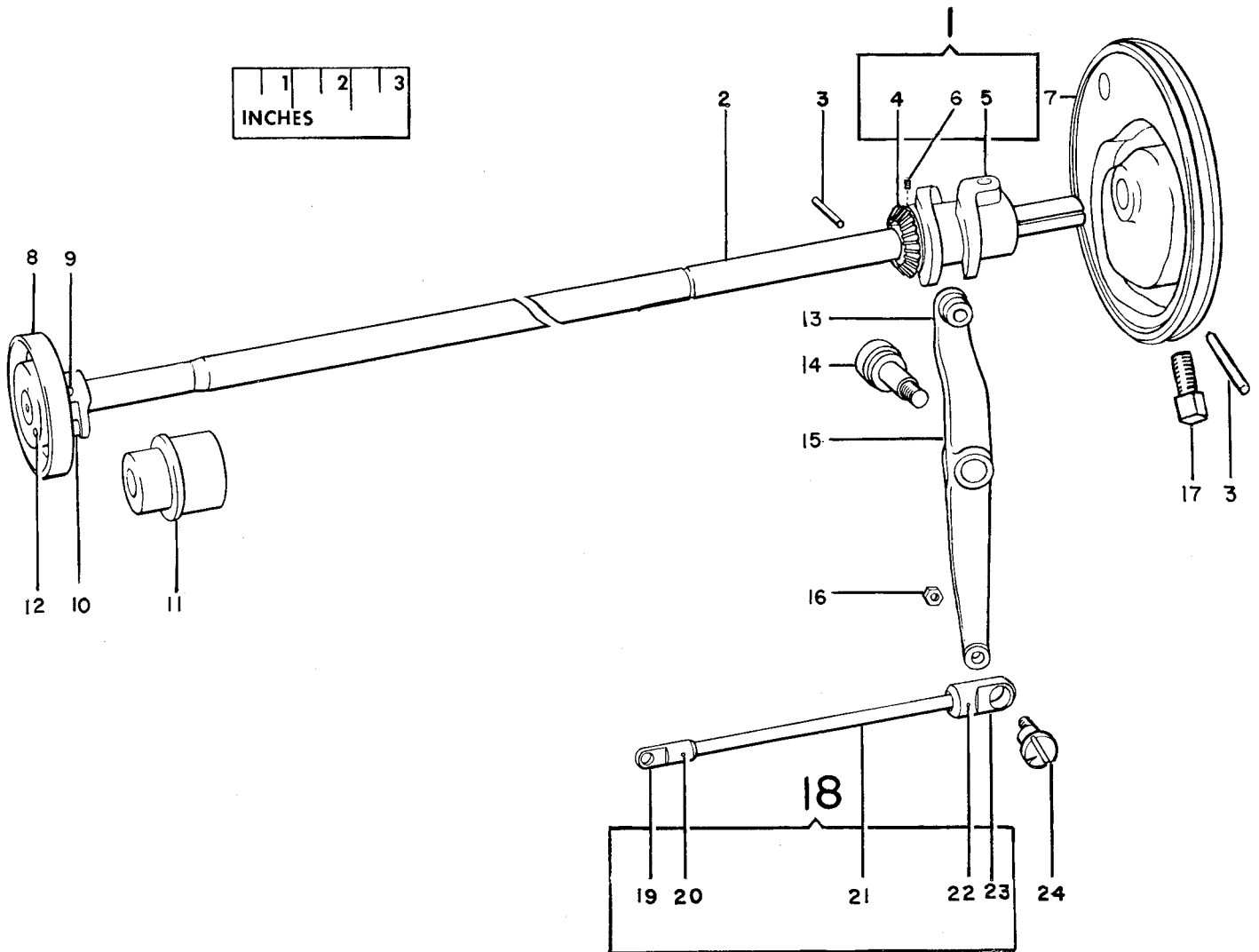

HEAD OF MACHINE AND TENSIONS COMPLETE

Ref. No.	Part No.	Description
1	193F	Screw
2	8620	Thread Eyelet (head of arm)
3	8574	Friction Spring
4	1177C	Clamping Screw
5	82154	Lifting Lever Shaft Lever with 1177C
6	82153	Lifting Lever Shaft
7	82155	Lifting Lever Shaft Adjusting Lever
8	515J	Clamping Screw
9	648J	Hinge Screw
10	1560W	Tension Thumb Nut (2)
11	8619	Tension Spring
12	668D	Adjusting Stud (top)
13	8617	Cup (release)
14	8618	Disc (2)
15	84113	Washer (leather)
16	8575	Friction Spring Pin
17	82058	Head of Machine
18	82116	Thread Guide Pin (side)
19	SS535W	Head Revolving Bush Stop Thumb Screw
20	* 413D	Adjusting Stud (side)
21	2102	Disc (2)
22	{ 2103	Tension (side) Spring (29K71, 29K73 Machines)
	{ 80548	Tension (side) Spring (29K72 Machine)
23	128D	Head Binding Screw (4)
24	NN101J	Slide Rod Lock Nut (upper)
25	82055	Foot Bar Revolving Joint Bearing
26	8569	Hinge Pin
27	NN96J	Lock Nut (lower)
28	82056	Slide Rod
29	82059	Lifter
30	66F	Hinge Screw
	8568	Vibrating Presser Lifting Lever Shaft Adjusting Lever Clamping Screw Rivet
	33892	Tension (side) Adjusting Stud 413D with 1560W
	82057	Foot Bar Revolving Joint complete, Nos. NN96J, NN101J, 82055 and 82056

HEAD OF MACHINE AND TENSIONS COMPLETE

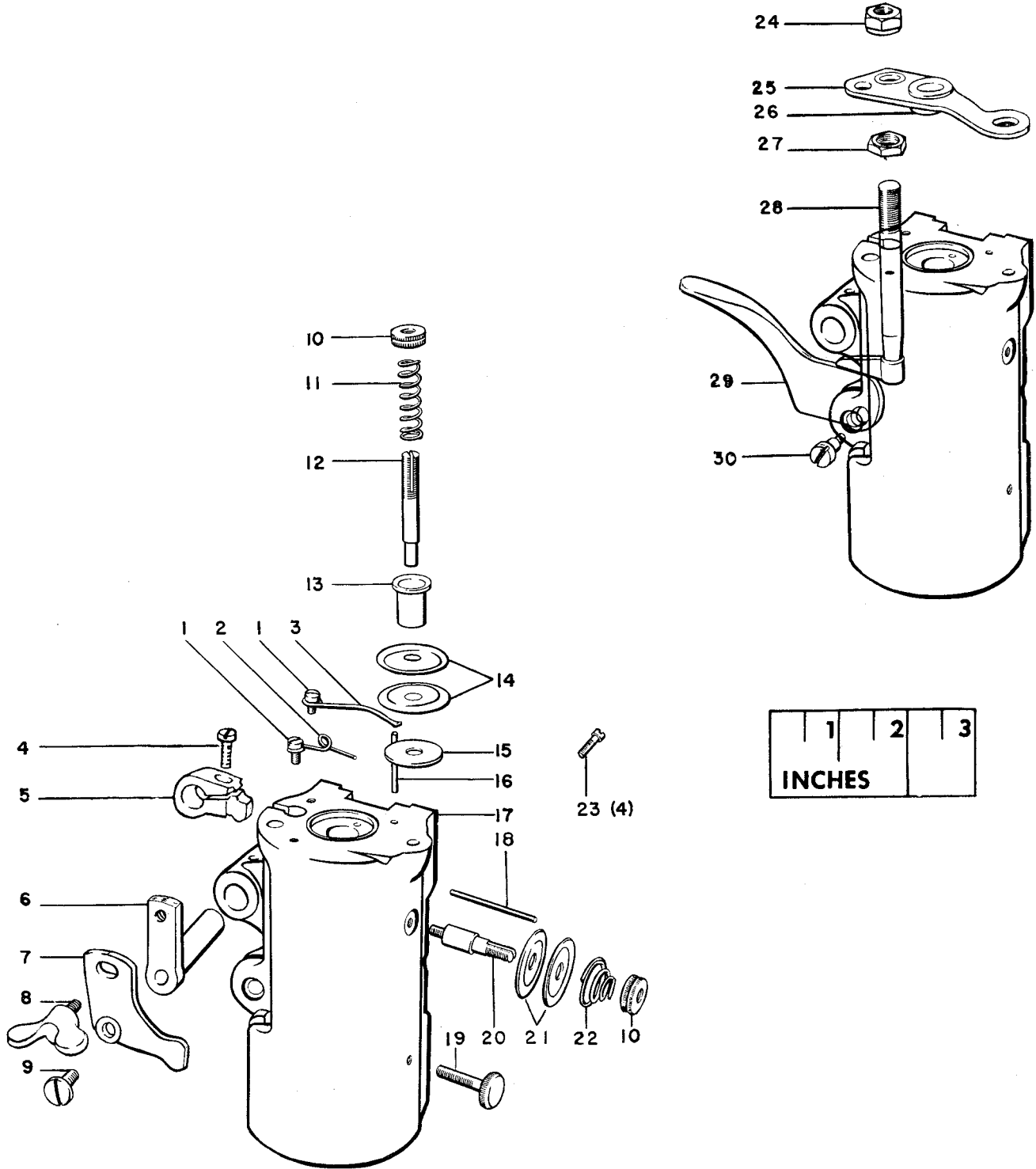

ARM SIDE COVERS, SHUTTLE DRIVING AND LIFTING LEVERS
MACHINE NO. 29K71

Ref. No.	Part No.	Description
1	NN105H	Stud Nut
2	82219	Spring
3	418J	Spring Stud
4	82220	Needle Bar Driving Lever with 1801 and 82216
5	82216	Spring Steady Pin
6	8601	Spool Pin
7	1801	Cam Roller and Stud
8	8586	Joint Pin
9	327D	Oil Cup Screw
10	8670	Oil Cup with 8597 and 8695
11	8597	Spring
12	8695	Oil Pad (cloth)
13	82150	Vibrating Presser Lifting Lever (for medium work)
14	41D	Lifting Lever Screw
15	51224W	Thumb Screw
16	82151	Lifting Lever (for light work)
17	82152	Lifting Lever (for heavy work)
18	SS 45E	Hub Screw(3)
19	82034	Arm Side Cover (front) for use when Machine is fitted with Hand Wheel on end of shaft
20	4288	Arm Side Cover (back)
21	82121	Hand Wheel Hub complete, Nos. 11663, 81869, 82008 and 82052
22	81869	Hand Wheel Shaft Gear
23	11663	Gear Pin
24	82008	Shaft
25	82052	Hub

ARM SIDE COVERS, SHUTTLE DRIVING AND LIFTING LEVERS
MACHINE NO. 29K71

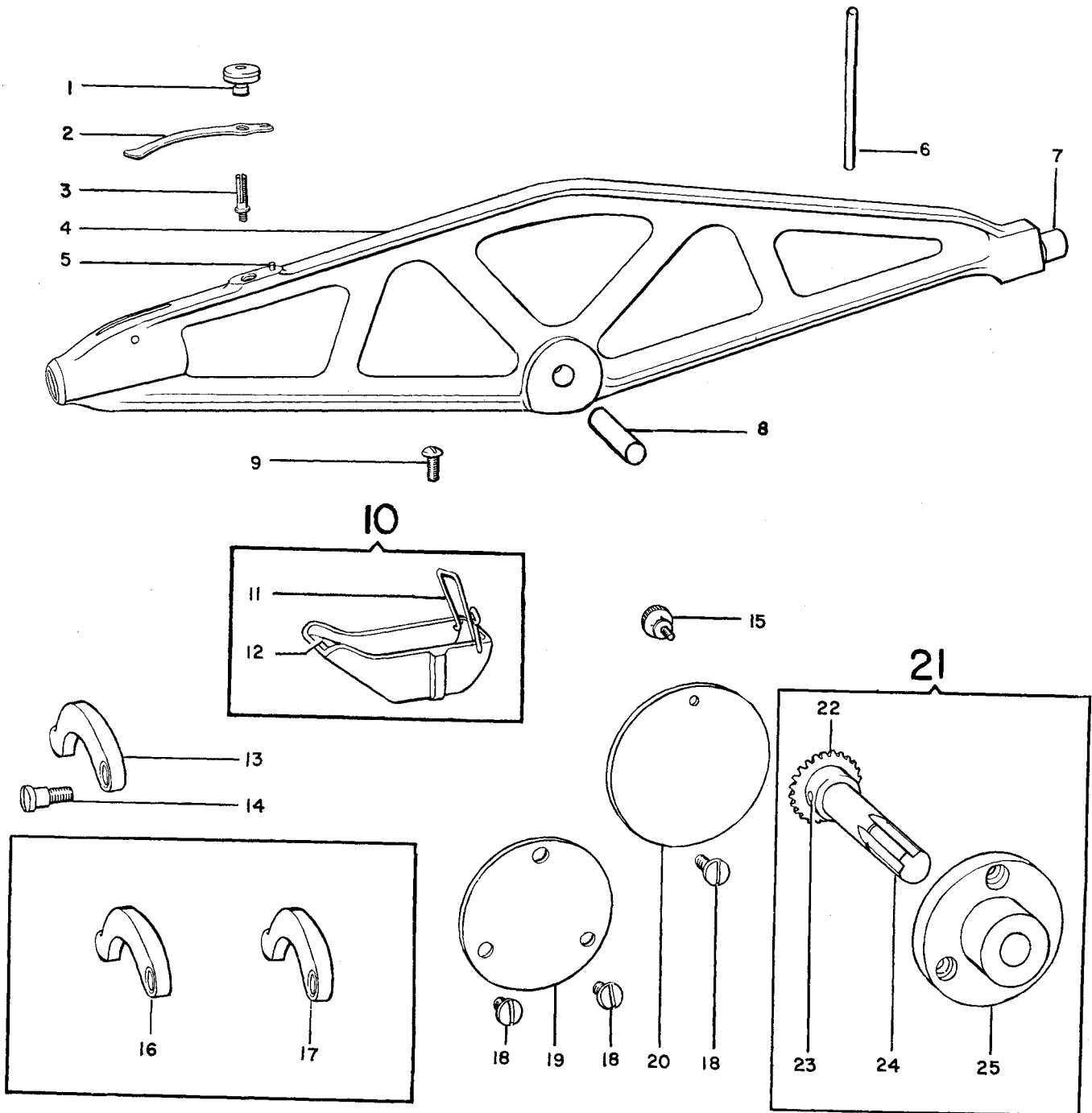

	1	2	3
INCHES			

ARM SIDE COVERS, SHUTTLE DRIVING AND LIFTING LEVERS
MACHINES NOS. 29K72 AND 29K73

Ref. No.	Part No.	Description
1	NN105H	Stud Nut
2	82219	Spring
3	418J	Spring Stud
4	82241	Needle Bar Driving Lever with 1801 and 82216
5	82216	Spring Steady Pin
6	8601	Spool Pin
7	1801	Cam Roller and Stud
8	81943	Joint Pin
9	327D	Oil Cup Screw
10	8670	Oil Cup with 8597 and 8695
11	8597	Spring
12	8695	Oil Pad (cloth)
13	82150	Vibrating Presser Lifting Lever (for medium work)
14	41D	Lifting Lever Screw
15	51224W	Thumb Screw
16	82151	Lifting Lever (for light work)
17	82152	Lifting Lever (for heavy work)
18	SS 45E	Hub Screw (3)
19	82034	Arm Side Cover (front) for use when Machine is fitted with Hand Wheel on end of shaft
20	4288	Arm Side Cover (back)
21	82121	Hand Wheel Hub complete, Nos. 11663, 81869, 82008 and 82052
22	81869	Hand Wheel Shaft Gear
23	11663	Gear Pin
24	82008	Shaft
25	82052	Hub

ARM SIDE COVERS, SHUTTLE DRIVING AND LIFTING LEVERS
MACHINE NOS. 29K72 AND 29K73

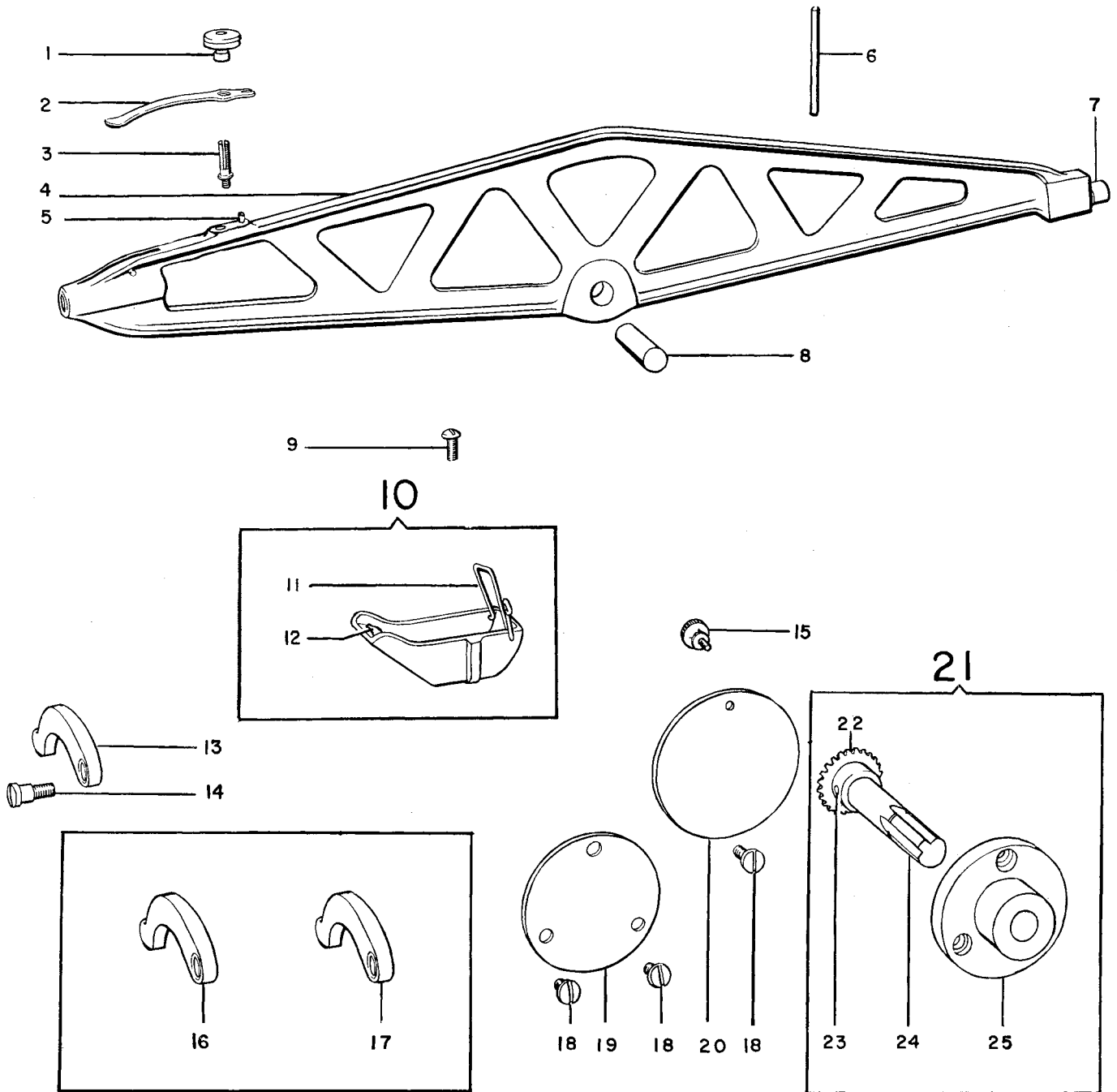

CHECK LEVER AND NEEDLE BAR COMPLETE

Ref. No.	Part No.	Description
1	8659	Check Lever
2	8554	Joint Pin
3	82231	Piston Joint (29K71 Machine)
	82199	Piston Joint (29K72, 29K73 Machines)
4	8589	Joint Pin
5	211D	Washer Screw (2)
6	8577	Head Revolving Bush Supporting Washer
7	82166	Check Lever Thread Take-up Adjusting Screw with Indicator complete, Nos. NN99K, NN100K, SS570K, 2975, 56033, 82164, 82165 and 82189
8	NN99K	Lock Nut
9	82164	Index Head
10	56033	Index Head Stop Pin
11	SS570K	Adjusting Screw
12	82165	Locating Plunger
13	2975	Spring
14	82189	Indicator Body
15	NN100K	Indicator Body Lock Nut
16	82031	Needle Bar complete, Nos. SS50F, 8656, 81858, 82030 and two SS133D (29K71, 29K73 Machines)
	82213	Needle Bar complete, Nos. SS50F, 8656, 81888, 82212 and two SS133D (29K72 Machine)
17	SS133D	Spring Screw (2)
18	8656	Thread Tension Spring
19	82030	Needle Bar (29K71, 29K73 Machines)
	82212	Needle Bar (29K72 Machine)
20	81858	Needle Bar Clamp with 237F (29K71, 29K73 Machines)
	81888	Needle Bar Clamp with 237F (29K72 Machine)
21	237F	Needle Clamping Screw
22	SS 50F	Clamp Screw

CHECK LEVER AND NEEDLE BAR COMPLETE

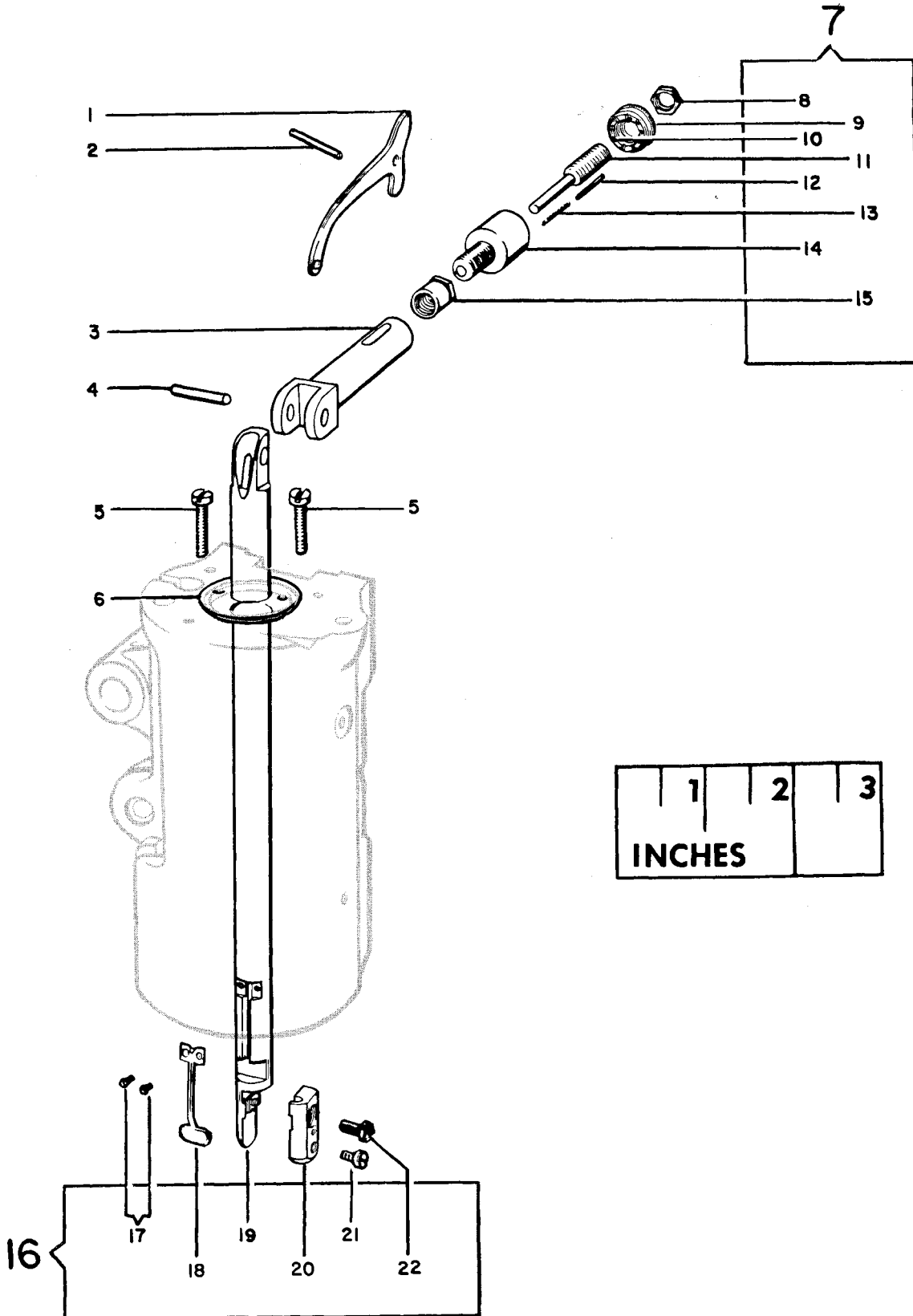

FOOT BAR AND FOOT BAR REVOLVING JOINT

Ref. No.	Part No.	Description
1	NN88W	Adjusting Nut
2	82130	Spring Bar
3	82129	Vibrating Presser Spring (heavy)
	82023	Vibrating Presser Spring (light)
		NOTE: Spring No. 82129 is supplied with these Machines unless otherwise specified on order.
4	8675	Foot Bar
5	179E	Collar Screw
6	82131	Spring Bar Collar
7	193F	Feeding Foot Screw
8	82007	Feeding Foot
		NOTE: Feeding Foot No. 82007 is supplied with Machines Nos. 29K71 and 29K73 unless otherwise specified on order.
		Feeding Foot No. 8666 is supplied with Machine No. 29K72 unless otherwise specified on order.
		(See Accessories page for extra Feeding Feet)
9	291W	Stitch Regulator Thumb Screw
10	1816	Roller and Stud
11	82053	Slide Bar with 1816
12	8573	Revolving Bush
13	194E	Joint Screw (2)
14	82123	Revolving Bush Handle
15	152F	Handle Screw (2)
16	82167	Bell Crank Lever
17	82230	Gib
18	82188	Stitch Regulator

FOOT BAR AND FOOT BAR REVOLVING JOINT

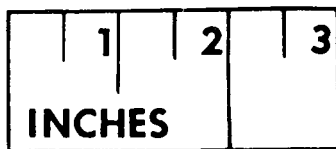
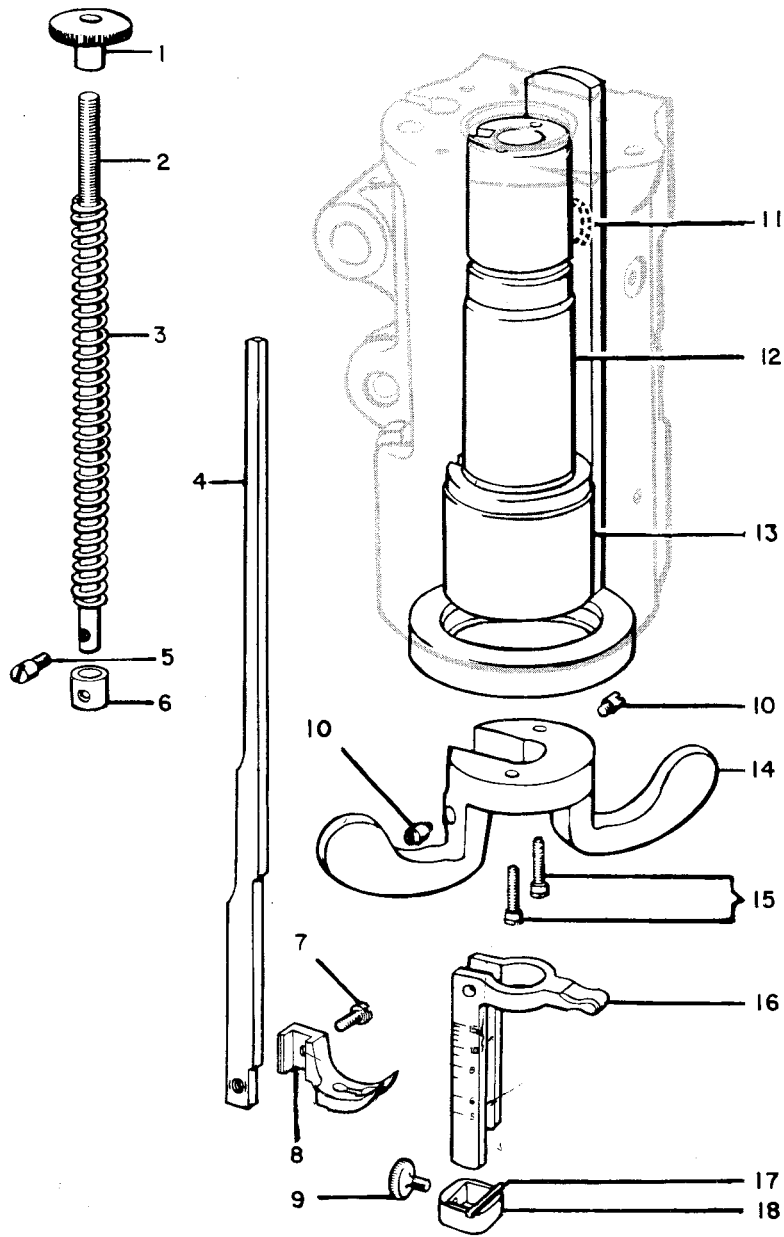

NEEDLE PLATES, GEAR BOX AND SHUTTLE COMPLETE
MACHINES NOS. 29K71 AND 29K73

Ref. No.	Part No.	Description
1	82240	Needle Plate Hinge Pin
2	82235	Needle Plate (fine and medium needle holes)
3	8603	Shuttle complete, Nos. 662F, 8604, 8611 and 8654
4	8604	Bobbin
5	* 8654	Shuttle Body
6	662F	Tension Regulating Screw
7	8611	Tension Spring
8	82177	Shuttle Carrier with 241D and 8610
9	8610	Spring
10	241D	Spring Screw
11	*82224	Gear Box
12	82179	Pinion Bushing
13	82176	Rack (short)
14	SS571AL	Pinion Screw
15	82178	Driving Pinion
16	82175	Rack (long)
17	82174	Pinion Cover Plate
18	1423J	Plate Screw (2)
19	82234	Needle Plate (medium and coarse needle holes)
20	82181	Following Pinion Stud
21	11661	Gear Box Position Pin
22	82063	Releasing Lever Hinge Pin
23	82173	Releasing Lever
24	82171	Locating Plunger
25	SS658	Needle Plate Hinge Pin Binding Screw
26	82172	Plunger Spring
27	82180	Following Pinion
28	146J	Gear Box Screw (2)
29	89E	Connecting Rod Hinge Screw
	82226	Shuttle Driving Gear Box complete, Nos. SS571AL, 82063, 82171, 82172, 82173, 82174, 82175, 82176, 82177, 82178, 82179, 82180, 82181, 82224 and two 1423J
	82242	Shuttle Driving Gear Box 82226 with SS658 and 82240
	82244	Shuttle Driving Gear Box 82224 with 82179 and 82181 (for Agents only)
	82245	Shuttle Driving Gear Box 82244 with SS258 and 82240 (for Agents only)

NEEDLE PLATES, GEAR BOX AND SHUTTLE COMPLETE
MACHINES NOS. 29K71 AND 29K73

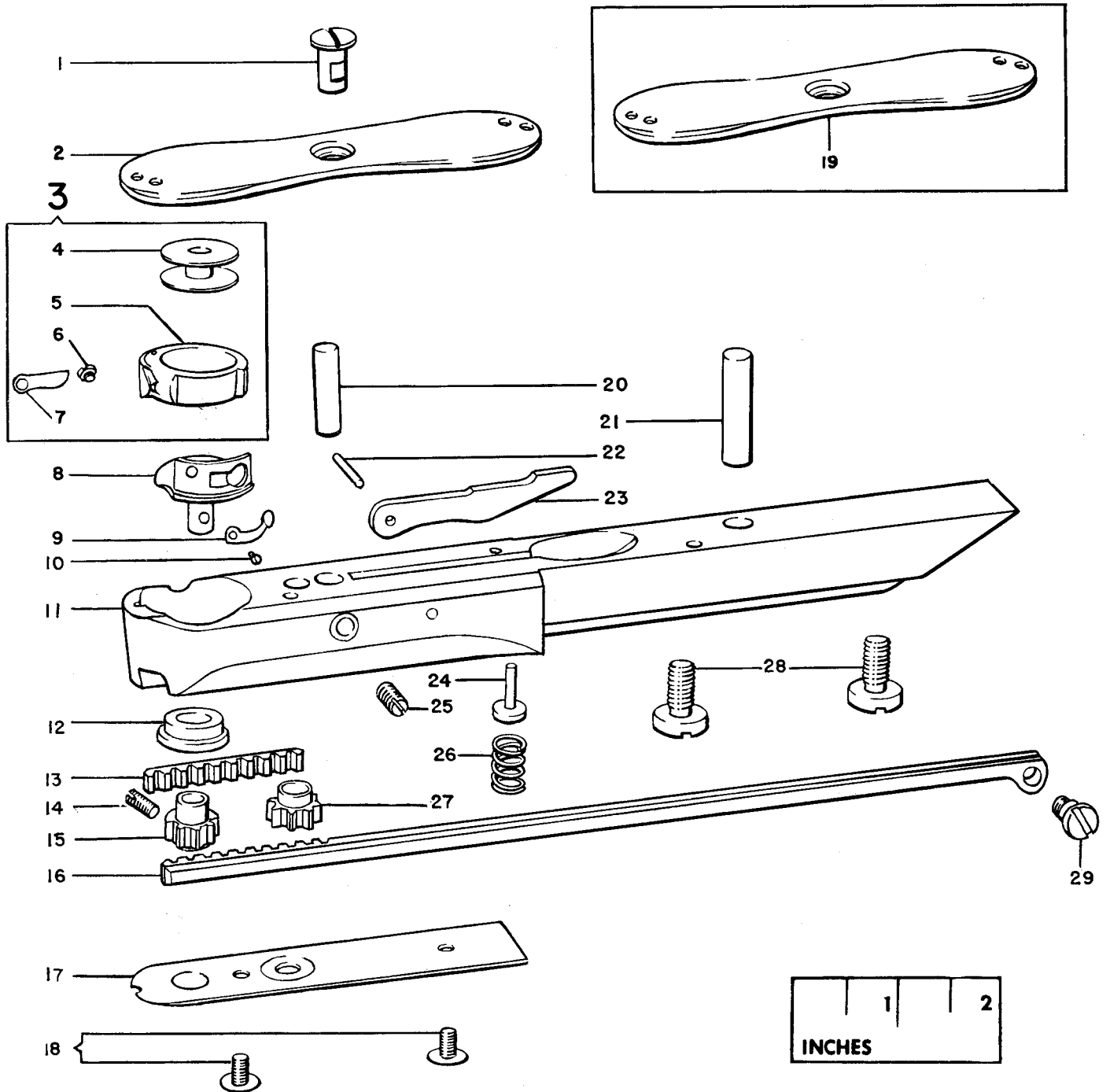

NEEDLE PLATES, GEAR BOX AND SHUTTLE COMPLETE
MACHINE NO. 29K72

Ref. No.	Part No.	Description
1	82240	Needle Plate Hinge Pin
2	82201	Needle Plate (fine and medium needle holes)
3	81952	Shuttle complete, Nos. SS132D, SS133D, 404D, 7868, 81951, 81993, 81994 and 82552
4	82552	Bobbin
5	<i>109</i> SS133D	Shuttle Bobbin Retaining Spring Screw <i>109133</i>
6	7868	Retaining Spring
7	*81993	Shuttle Body
8	SS132D	Tension Regulating Screw
9	81994	Tension Spring
10	81951	Shuttle Thread Pull-off
11	404D	Pull-off Screw
12	82205	Shuttle Carrier
13	*82225	Shuttle Driving Gear Box
14	82179	Pinion Bushing
15	82176	Rack (short)
16	SS571AL	Pinion Screw
17	82206	Driving Pinion
18	82175	Rack (long)
19	82204	Pinion Cover Plate
20	1423J	Plate Screw (2)
21	82202	Needle Plate (medium and coarse needle holes)
22	82181	Following Pinion Stud
23	82208	Gear Box Position Pin
24	82063	Releasing Lever Hinge Pin
25	82173	Releasing Lever
26	82171	Locating Plunger
27	SS658	Needle Plate Hinge Pin Binding Screw
28	82203	Plunger Spring
29	82180	Following Pinion
30	146J	Gear Box Screw (2)
31	89E	Connecting Rod Hinge Screw
	82227	Shuttle Driving Gear Box complete, Nos. SS571AL, 82063, 82171, 82173, 82175, 82176, 82179, 82180, 82181, 82203, 82204, 82205, 82206, 82225 and two 1423J
	82243	Shuttle Driving Gear Box 82227 with SS658 and 82240
	82246	Shuttle Driving Gear Box 82225 with 82179 and 82181 (for Agents only)
	82247	Shuttle Driving Gear Box 82246 with SS658 and 82240 (for Agents only)

NEEDLE PLATES, GEAR BOX AND SHUTTLE COMPLETE MACHINE NO. 29K72

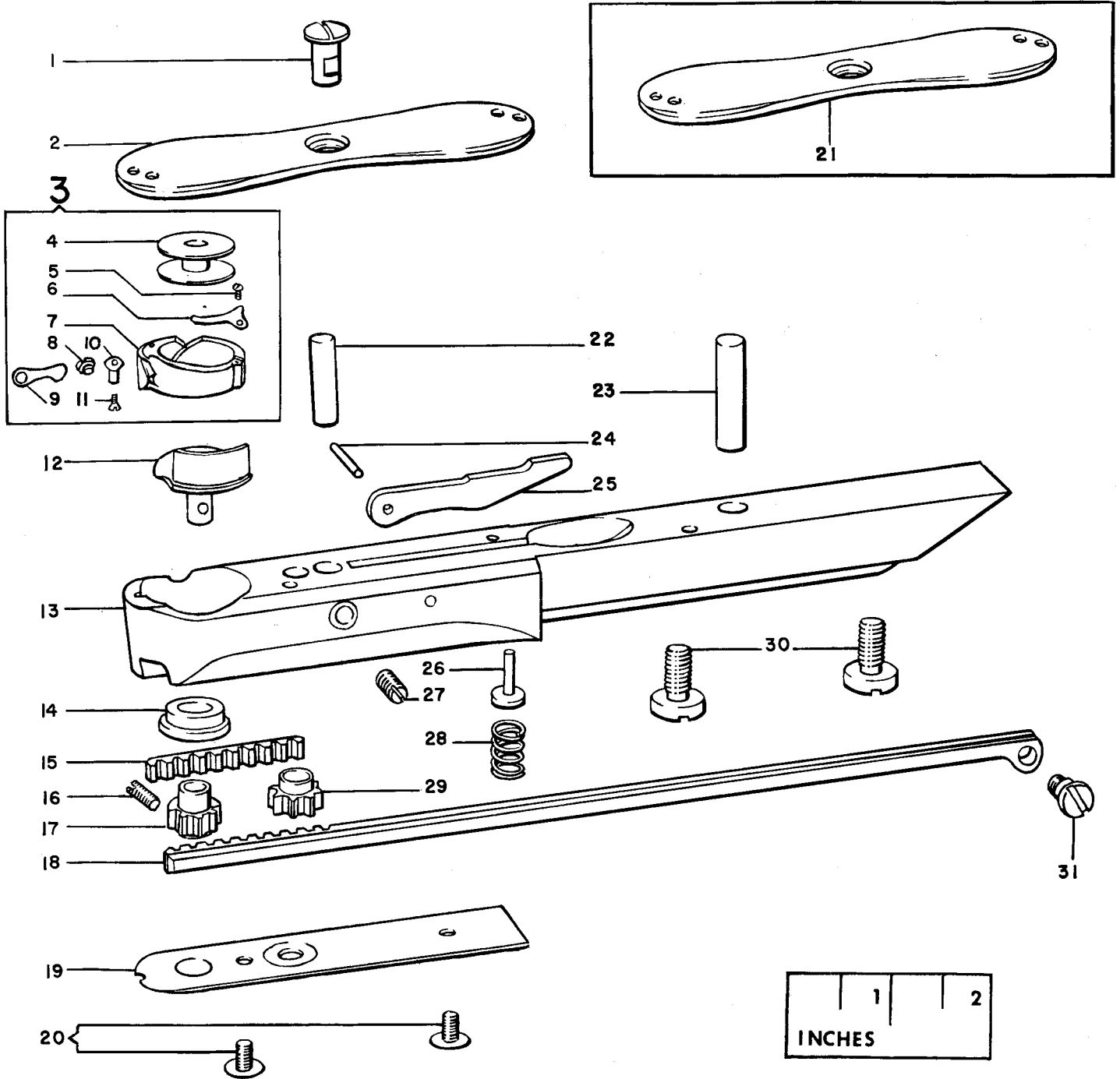

HAND WHEEL AND STOP MOTION COMPLETE

Ref. No.	Part No.	Description
1	82163	Hand Wheel and Stop Motion complete, Nos. NN98R, SS135D, SS569C, 761C, 1519E, 81866, 82159, 82160, 82161 and 82162
2	1519E	Nut
3	434C	Binding Screw (2)
4	82160	Hand Wheel Stop Motion Flanged Bushing with two 434C
5	82162	Spring
6	82161	Stop Motion Plunger
7	82159	Hand Wheel
8	NN98R	Plunger Thumb Nut
9	81866	Handle (wood)
10	SS135D	Spindle
11	SS569C	Retaining Screw
12	761C	Plunger Stop Screw

HAND WHEEL AND STOP MOTION COMPLETE

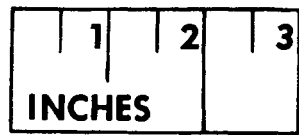
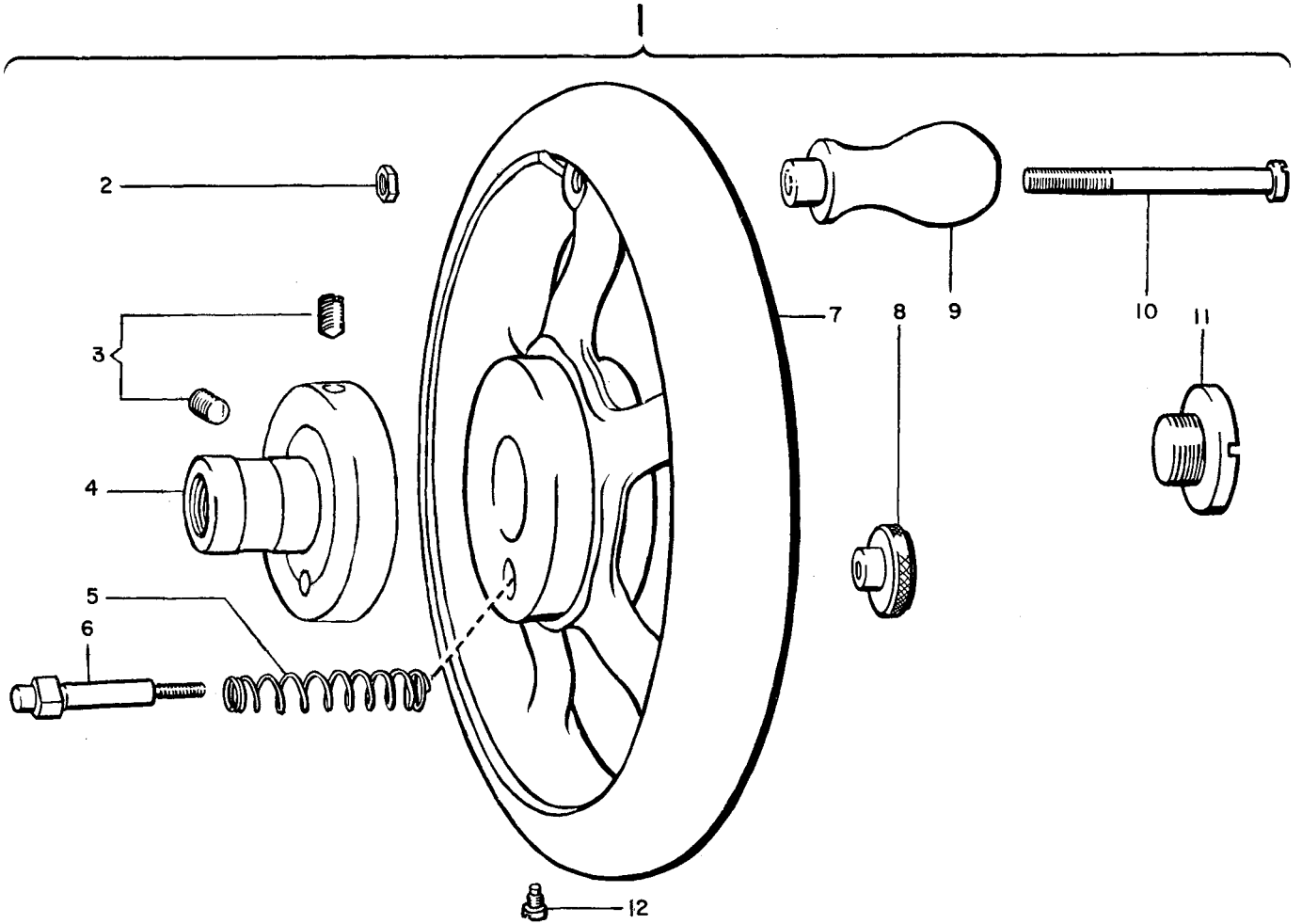

BOBBIN WINDER COMPLETE
MACHINES NOS. 29K71 AND 29K73

Ref. No.	Part No.	Description
1	82087	Bobbin Winder complete, Nos. 128D, SS469W, 2460, 8684, 81965 and 82086
2	128D	Frame Screw
3	8651	Spindle
4	82086	Frame
5	8684	Eccentric
6	SS469W	Eccentric Thumb Screw
7	8371	Pulley
8	2460	Rubber Ring
	81965	Spindle 8651 with 8371

BOBBIN WINDER COMPLETE
MACHINES NOS. 29K71 AND 29K73

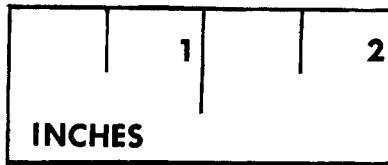
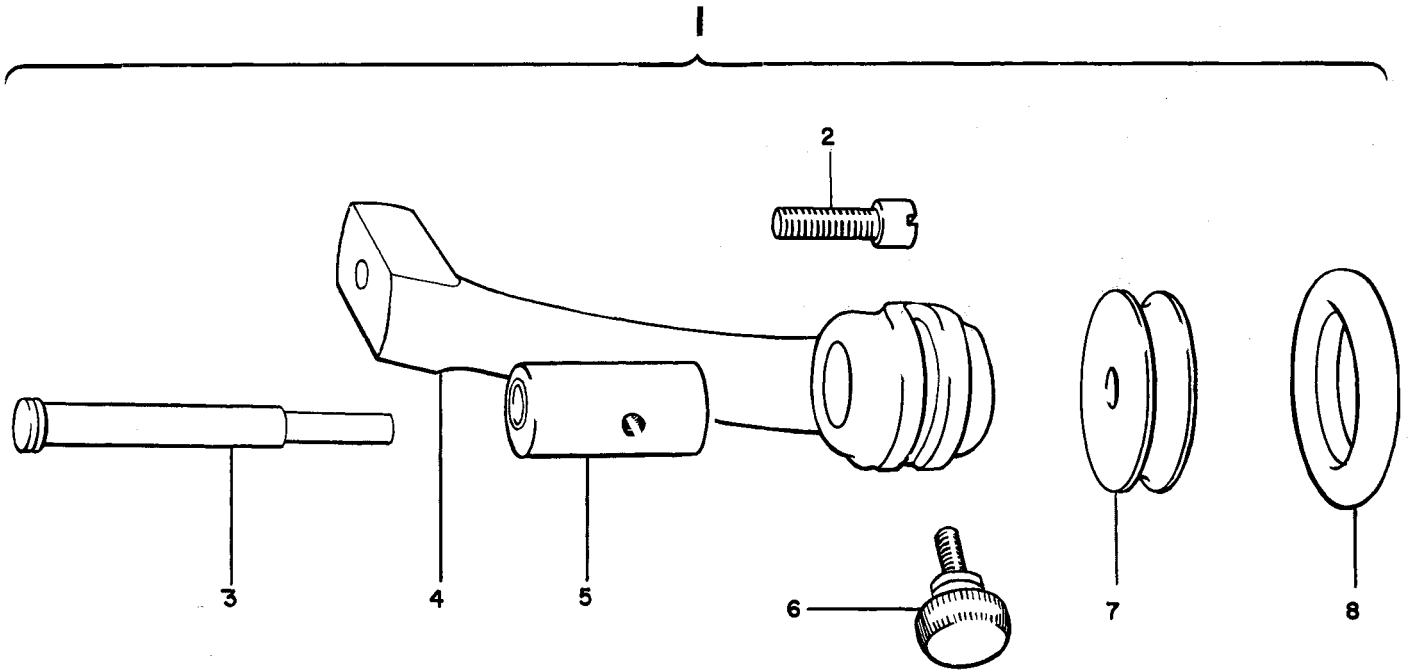

BOBBIN WINDER COMPLETE
MACHINE NO. 29K72

Ref. No.	Part No.	Description
1	82090	Bobbin Winder complete, Nos. 128D, SS469W, 2460, 8684, 82086 and 82089
2	128D	Frame Screw
3	82088	Spindle
4	82086	Frame
5	8684	Eccentric
6	SS469W	Eccentric Thumb Screw
7	8371	Pulley
8	2460	Rubber Ring
	82089	Spindle 82088 with 8371

BOBBIN WINDER COMPLETE
MACHINE NO. 29K72

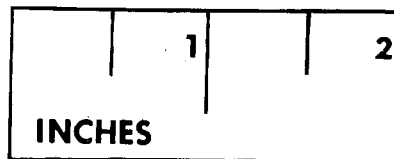
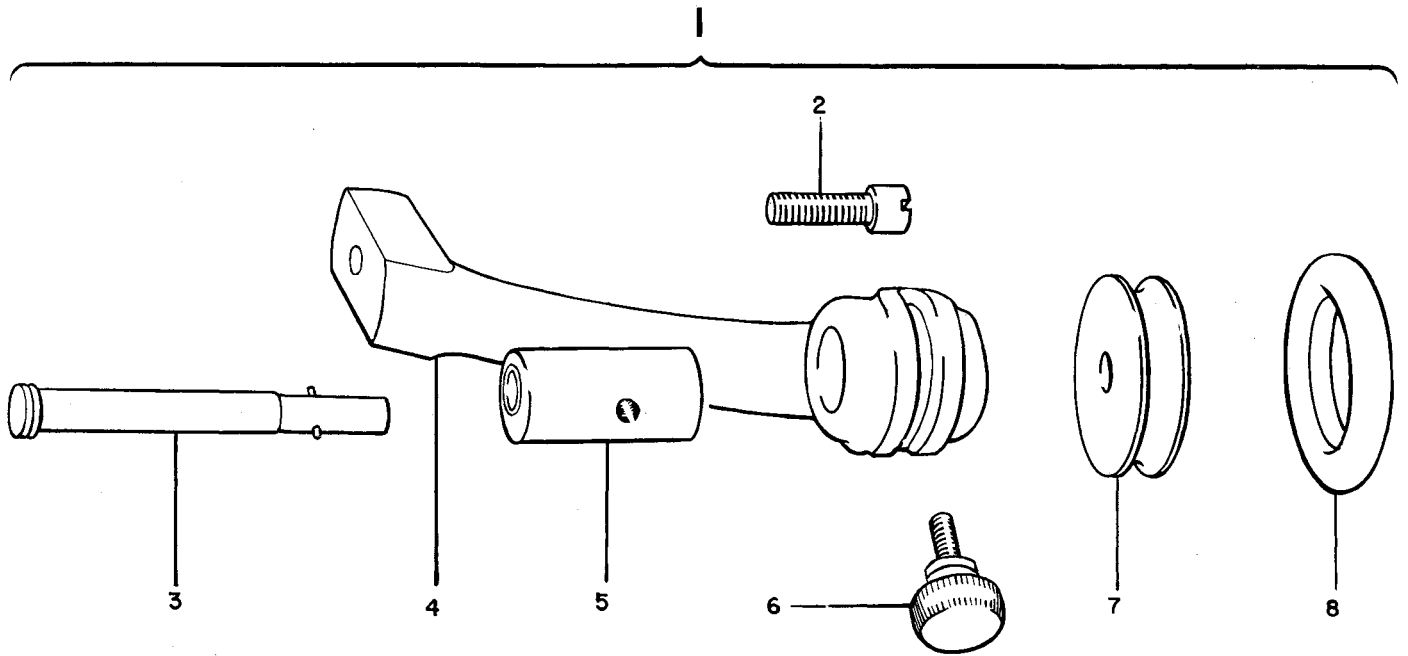

ACCESSORIES

Ref. No.	Part No.	Description
1	36570	Oiler 36569 (filled with oil)
2	36571	Oiler Spout, 1-3/4 inch long with 36807
3	36807	Washer (leather)
4	36569	Oiler with 36571
5	25537	Screw Driver (machine)
6	120378	Screw Driver (shuttle tension)
7	418E	Machine Screw (for fastening Machine to Power Table) (4)
8	82833	Machine Screw Washer (4)
9	50616	Machine Screw (for fastening Machine to Stand) (4)
10	8604	Bobbin (29K71, 29K73 Machines) (2)
11	82552	Bobbin (29K72 Machine) (2)
12	8582	Steady Pin (2)
13	8590	Threading Wire

FEEDING FEET

14	8557	Feeding Foot (narrow fork, fine)
15	8558	Feeding Foot (narrow fork, coarse)
16	8666	Feeding Foot (for waxed thread)

NOTE: No. 8666 is used on Machine No. 29K72, unless otherwise specified on order.

ACCESSORIES

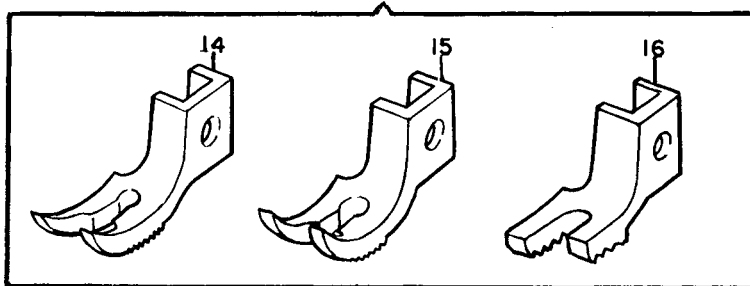
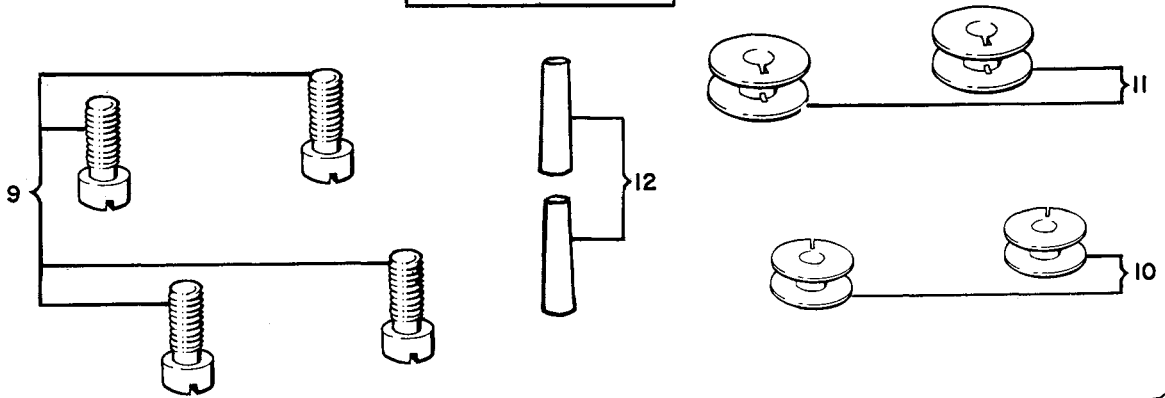
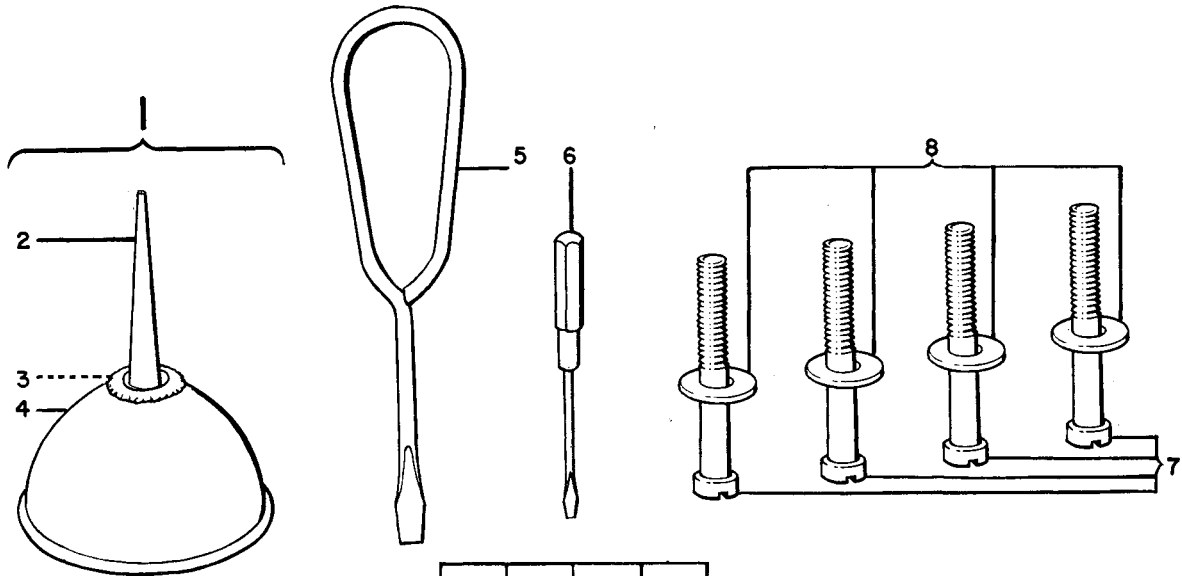

MACHINE BASES FOR POWER TABLES

Ref. No.	Part No.	Description
82214		Machine Base, for No. 29K71 Machine
82113		Machine Base, for Nos. 29K72 and 29K73 Machines
50616		Machine Base Screw (for fastening Base to Machine) (4) NOTE: Illustrated on page 40 Ref. No. 9
		Machine Base Screw (wood) 1 in. No. 12 (for fastening Base to Power Table) (4) NOTE: These bases are only supplied when specified on order and are charged extra.

NUMERICAL LIST OF PARTS

Part No.	Page No.	Part No.	Page No.	Part No.	Page No.
RR 18.....	18	SS658.....	30, 32	8645.....	18
41D.....	22, 24	662F.....	30	8651.....	36
SS 45E.....	22, 24	668D.....	20	*8654.....	30
SS 50F.....	26	761C.....	34	8656.....	26
66F.....	20	1177C.....	20	8659.....	26
NN 88W.....	28	1423J.....	30, 32	8661.....	18
89E.....	30, 32	1519E.....	34	8666.....	40
NN 96J.....	20	1520R.....	18	8670.....	22, 24
NN 98R.....	34	1560W.....	20	8675.....	28
NN 99K.....	26	1801.....	22, 24	8684.....	36, 38
NN100K.....	26	1808.....	18	8695.....	22, 24
NN101J.....	20	1816.....	28	11661.....	30
NN105H.....	22, 24	2102.....	20	11663.....	18, 22, 24
128D.....	20, 36, 38	2103.....	20	25537.....	40
SS132D.....	32	2460.....	36, 38	33892.....	20
SS133D.....	26, 32	2975.....	26	36569.....	40
SS135D.....	34	3012.....	18	36570.....	40
146J.....	30, 32	4288.....	22, 24	36571.....	40
152F.....	28	4449.....	18	36807.....	40
179E.....	28	7868.....	32	50616.....	40, 42
193F.....	20, 28	8371.....	36, 38	51224W.....	22, 24
194E.....	28	8554.....	26	56033.....	26
211D.....	26	8557.....	40	80548.....	20
SS235C.....	18	8558.....	40	81858.....	26
237F.....	26	8568.....	20	81866.....	34
241D.....	30	8569.....	18, 20	81868.....	18
291W.....	28	8573.....	28	81869.....	22, 24
327D.....	22, 24	8574.....	20	81872.....	18
361C.....	18	8575.....	20	81888.....	26
404D.....	32	8577.....	26	81941.....	18
* 413D.....	20	8582.....	40	81943.....	24
418E.....	40	8586.....	22	81951.....	32
418J.....	22, 24	8589.....	26	81952.....	32
434C.....	34	8590.....	40	81965.....	36
SS469W.....	36, 38	8597.....	22, 24	*81993.....	32
515J.....	20	8601.....	22, 24	81994.....	32
SS535W.....	20	8603.....	30	82007.....	28
SS569C.....	34	8604.....	30, 40	82008.....	22, 24
SS570K.....	26	8610.....	30	82010.....	18
SS571AL.....	30, 32	8611.....	30	82011.....	18
SS572C.....	18	8617.....	20	82030.....	26
SS573C.....	18	8618.....	20	82031.....	26
SS575C.....	18	8619.....	20	82034.....	22, 24
648J.....	20	8620.....	20	82052.....	22, 24

NUMERICAL LIST OF PARTS

Part No.	Page No.	Part No.	Page No.	Part No.	Page No.
82053.....	28	82177.....	30	82246.....	32
82055.....	20	82178.....	30	82247.....	32
82056.....	20	82179.....	30, 32	82552.....	32, 40
82057.....	20	82180.....	30, 32	82833.....	40
82058.....	20	82181.....	30, 32	84113.....	20
82059.....	20	82184.....	18	120378.....	40
82063.....	30, 32	82186.....	18		
82073.....	18	82188.....	28		
82083.....	28	82189.....	26		
82086.....	36, 38	82194.....	18		
82087.....	36	82199.....	26		
82088.....	38	82201.....	32		
82089.....	38	82202.....	32		
82090.....	38	82203.....	32		
82113.....	42	82204.....	32		
82116.....	20	82205.....	32		
82121.....	22, 24	82206.....	32		
82122.....	18	82208.....	32		
82123.....	28	82212.....	26		
82129.....	28	82213.....	26		
82130.....	28	82214.....	42		
82131.....	28	82216.....	22, 24		
82149.....	18	82219.....	22, 24		
82150.....	22, 24	82220.....	22		
82151.....	22, 24	*82224.....	30		
82152.....	22, 24	*82225.....	32		
82153.....	20	82226.....	30		
82154.....	20	82227.....	32		
82155.....	20	82230.....	28		
82159.....	34	82231.....	26		
82160.....	34	82232.....	18		
82161.....	34	82233.....	18		
82162.....	34	82234.....	19		
82163.....	34	82235.....	30		
82164.....	26	82236.....	18		
82165.....	26	82237.....	18		
82166.....	26	82238.....	18		
82167.....	28	82239.....	18		
82171.....	30, 32	82240.....	30, 32		
82172.....	30	82241.....	24		
82173.....	30, 32	82242.....	30		
82174.....	30	82243.....	32		
82175.....	30, 32	82244.....	30		
82176.....	30, 32	82245.....	30		

I N D E X

	Page		Page
Accessories (List).....	3	Oiling the Machine.....	4
Adjustments.....	12-16	Operation of Machine.....	5
Bobbin:		Parts List.....	17-42
Removal.....	6	Perfect Stitch.....	11
Replacement.....	6	Preparation for Sewing.....	10
Winding.....	6	Presser Bar Height, Setting.....	13
Bobbin Thread Tension.....	11	Presser Bar Lift.....	13
Bobbin Winder.....	6	Pressure on Material.....	13
Description of Machines.....	3	Rack Box:	
Description		Removal and Inspection.....	15
of Oils.....	Cover	Removing the Work.....	10
Direction of Feed.....	13	Shuttle:	
Feeding Foot Lift.....	13	Threading.....	7-8
Foreword.....	2	Timing.....	16
Hand Wheel.....	6	Special Characteristics.....	3
Height Adjustment:		Speed.....	4
Feeding Foot.....	13	Start Sewing.....	10
Needle Bar.....	12	Stitch Length.....	12
Hints for perfect Operation.....	14	Stop Motion (Hand Wheel).....	6
Information for Operator.....	5-16	Tensions:	
Length of Stitch.....	12	Explanation.....	11
Needles:		Regulation for Needle	
Class and Variety.....	5	Thread and Bobbin Thread....	11
Ordering.....	5	Thread Twist.....	5
Setting.....	9	Thread Take-up Lever	
Sizes recommended.....	5	Regulation and Adjustment....	12
Needle and Thread Relationship..	5	Threading:	
Needle Plate.....	13	Upper (Needle).....	9-10
Needle Thread Tension.....	11	Lower (Bobbin).....	7-8
Needle Thread Twist.....	5	Timing the Shuttle.....	16
Numerical List of Parts.....	43-44		

TO ALL WHOM IT MAY CONCERN:

The improper placing or renewal of the Trademark "**SINGER**" or any other of the Trademarks of The Singer Manufacturing Company (all of which are duly Registered Trademarks) on any machine that has been repaired, rebuilt, reconditioned, or altered in any way whatsoever outside a SINGER factory or an authorized SINGER agency is forbidden.

THE IMPORTANCE OF USING
SINGER** PARTS AND NEEDLES
IN SINGER MACHINES

The successful operation of SINGER machines can only be assured if SINGER parts and needles are used. Supplies are available at all SINGER Shops for the Manufacturing Trade, and mail orders will receive prompt attention.

SINGER Needles should be used
in SINGER Machines
These Needles and their Containers
are marked with the
Company's Trademark "**SIMANCO**" 1

Needles in Containers marked
"**FOR SINGER MACHINES**"
are NOT SINGER made needles 2

