

NS3L500MTGEVB

3.3V, 8-Channel, 2:1 Gigabit Ethernet LAN Switch with LED Switch Evaluation Board User's Manual



ON Semiconductor®

<http://onsemi.com>

EVAL BOARD USER'S MANUAL

Overview

The NS3L500 is an 8-channel 2:1 LAN switch with 3 additional built-in SPDT switches for LED routing. This switch is ideal for Gigabit LAN applications due to its low ON-state resistance and capacitance giving the switch a typical bandwidth of 800 MHz. The switch also has excellent ON-state resistance match, low bit-to-bit skew, and low crosstalk among channels. The switch is bidirectional and offers little or no attenuation of the high-speed signals at the outputs.

This part can be used to replace mechanical relays in low-voltage LAN applications that interface a physical layer over CAT 5 or CAT 6 unshielded twisted pair cable through an isolation transformer. The NS3L500 is available in a 56-pin WQFN package and operates over the extended -40°C to $+85^{\circ}\text{C}$ temperature range.

The NS3L500 evaluation board has been designed for a quick evaluation of the NS3L500. Among its main characteristics, this evaluation board has been constructed to easily interface with a customer's systems and equipment through SMA connectors. This document provides a bill of materials, board schematic, and a layout overview of the evaluation board. The appropriate lab test setups are also provided.

This document should be used with the NS3L500 datasheet available on www.onsemi.com. The datasheet contains full technical details about the NS3L500 specifications and operation. The evaluation board is implemented in four metal layers with $50\ \Omega$ characteristic impedance. The PCB dimensions are 50mm by 57.6 mm.

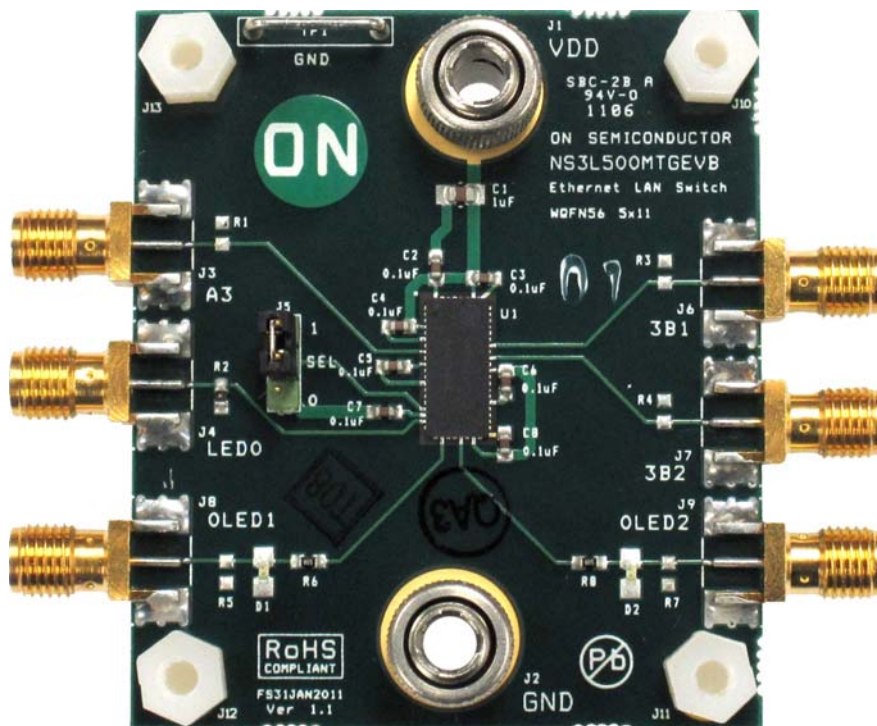

Figure 1. NS3L500 Evaluation Board Photo

NS3L500MTGEVB

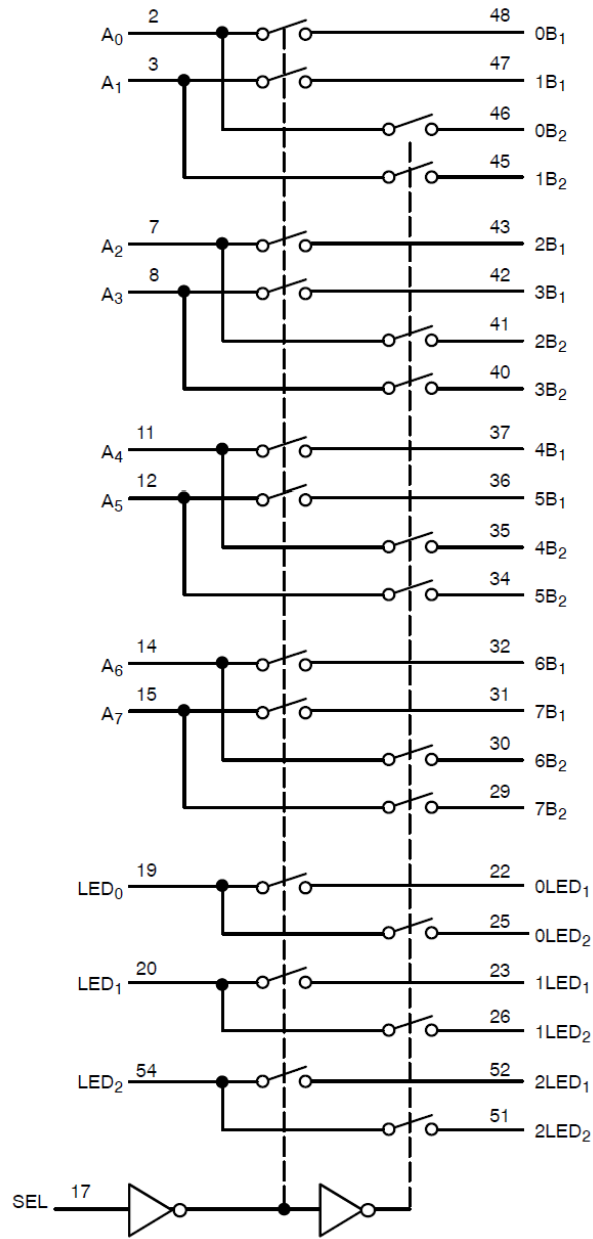

Figure 2. Block Diagram

PIN DESCRIPTION

Pin Name	Description
A _x	Data I/Os
xB _y	Data I/Os
SEL	Select Input
LED _x	LED I/O Port
xLED _y	LED I/O Port

TRUTH TABLE

SEL	Function
L	A _x to xB ₁ : LED _x to xLED ₁
H	A _x to xB ₂ : LED _x to xLED ₂

NS3L500MTGEVB

Equipment

The following table details the equipment used in the context of this application note manual:

Table 1. EQUIPMENT

Description	Quantity
Regulated DC Power Supply	1
Banana Cable	2
Oscilloscope with SMA Adapters	1
Differential Waveform Generator	1
SMA Cable	2-3

Get Started...

I. Set the power supply to 3.3 V. Connect the power supply to V_{CC} and GND on the board using the banana cables. The supply current should be less than 1 μ A.

II. To observe the switching of the data I/O channels:

1. Use an SMA cable to connect the function generator to A3. Adjust the internal impedance of the waveform generator 50 ohms. Set the desired bit rate up to 1 Gbps (1000BASE-T) and amplitude up to 3 Vpp per differential channel. Set the frequency and pattern to a 1 Gbps square wave (1000BASE-T). Do not turn on the generator until the load has been connected.
2. Connect channels 3B1 and 3B2 to the oscilloscope through single-ended 50 Ω probes.
3. Turn on the generator.
4. Move the jumper at J5 to change the logic level of SEL in order to switch between 3B1 and 3B2.

III. To observe switching of the LED I/O channels:

1. LED0 can be connected directly to V_{CC} or to the function generator. If using the function generator, use an SMA cable to connect the function generator to LED0, which has been set up as the LED input channel. Set the function generator to the desired pulse frequency from 0 to V_{CC} .
2. Move the jumper at J5 to change the logic level of SEL in order to switch between 0LED1 and 0LED2. Observe the switching of the LEDs at D1 and D2. The outputs should not be connected to the oscilloscope.
3. In order to observe LED channel switching on an oscilloscope, remove diodes at D1 and D2 and series resistors at D6 and D8. Solder 0 Ω resistors at D6 and D8. The LED channels can now be tested in the same manner as the data I/O channels in the previous section.

NS3L500MTGEVB

SCHEMATIC

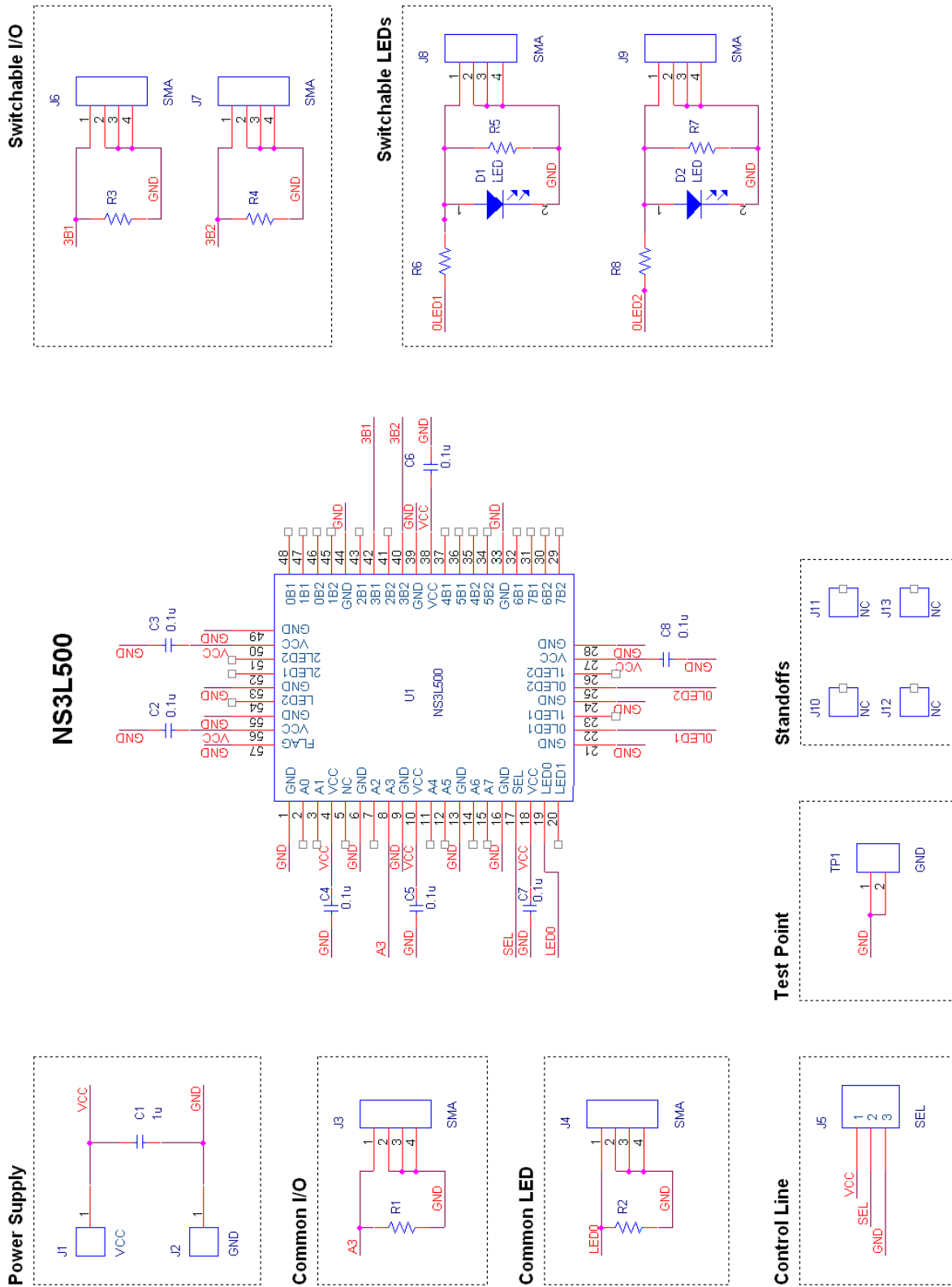

Figure 3. Board Schematic

NS3L500MTGEVB

Table 2. BILL OF MATERIALS

Designator	Qty	Description	Value	Tolerance	Footprint	Manufacturer	Manufacturer Part Number
C1	1	Ceramic Capacitor SMD	1 μ F	10%	805	TDK Corporation	C2012Y5V1C105Z/0.85
C2, C3, C4, C5, C6, C7, C8	7	Ceramic Capacitor SMD	0.1 μ F	10%	603	Yageo	CC0603ZRY5V7BB104
D1, D2	2	LED	n/a	n/a	0603/0805	Panasonic	LNJ326W83RA
R1, R3, R4, R5, R7	5	Do not populate	n/a	n/a	n/a	n/a	n/a
R2	1	0.2W Surface Mount Resistor	51	1%	603	Rohm Semiconductor	ESR03EZPF51R0
R6, R8	2	0.125W Surface Mount Resistor	392	1%	603	Stackpole Electronics Inc	RNCP 0603 T1 392 1% R
J1, J2	2	Banana Connector	n/a	n/a	7mm Hole	Johnson Components	111-2223-001
J3, J4, J6, J7, J8, J9	6	SMA Connector	n/a	n/a	n/a	Emerson Network Power Connectivity Solutions	142-0711-821
J10, J11, J12, J13	4	Standoff Nut	n/a	n/a	n/a	Keystone Electronics	1903C
J10, J11, J12, J13	4	Standoff Screw	n/a	n/a	n/a	Keystone Electronics	4814K-ND
J5	1	3-pin Header	n/a	n/a	Header3	Tyco Electronics	5-826629-0
J5	1	2-pin Jumper	n/a	n/a	n/a	3M	969102-0000-DA
TP1	1	PCB Shorting Link	n/a	n/a	n/a	Harwin	D3082-46
U1	1	NS3L500	n/a	n/a	WQFN56 5x11, 0.5P	ON Semiconductor	NS3L500MTTWGTAG

NS3L500MTGEVB

PCB Design

The PCB is implemented in four metal layers and FR-4 dielectric. Signal traces on the PCB have 50 Ω characteristic impedance to minimize high speed signal loss. The PCB is

made of lead-free and RoHS compliant materials. The PCB dimensions are 50 mm by 57.6 mm.

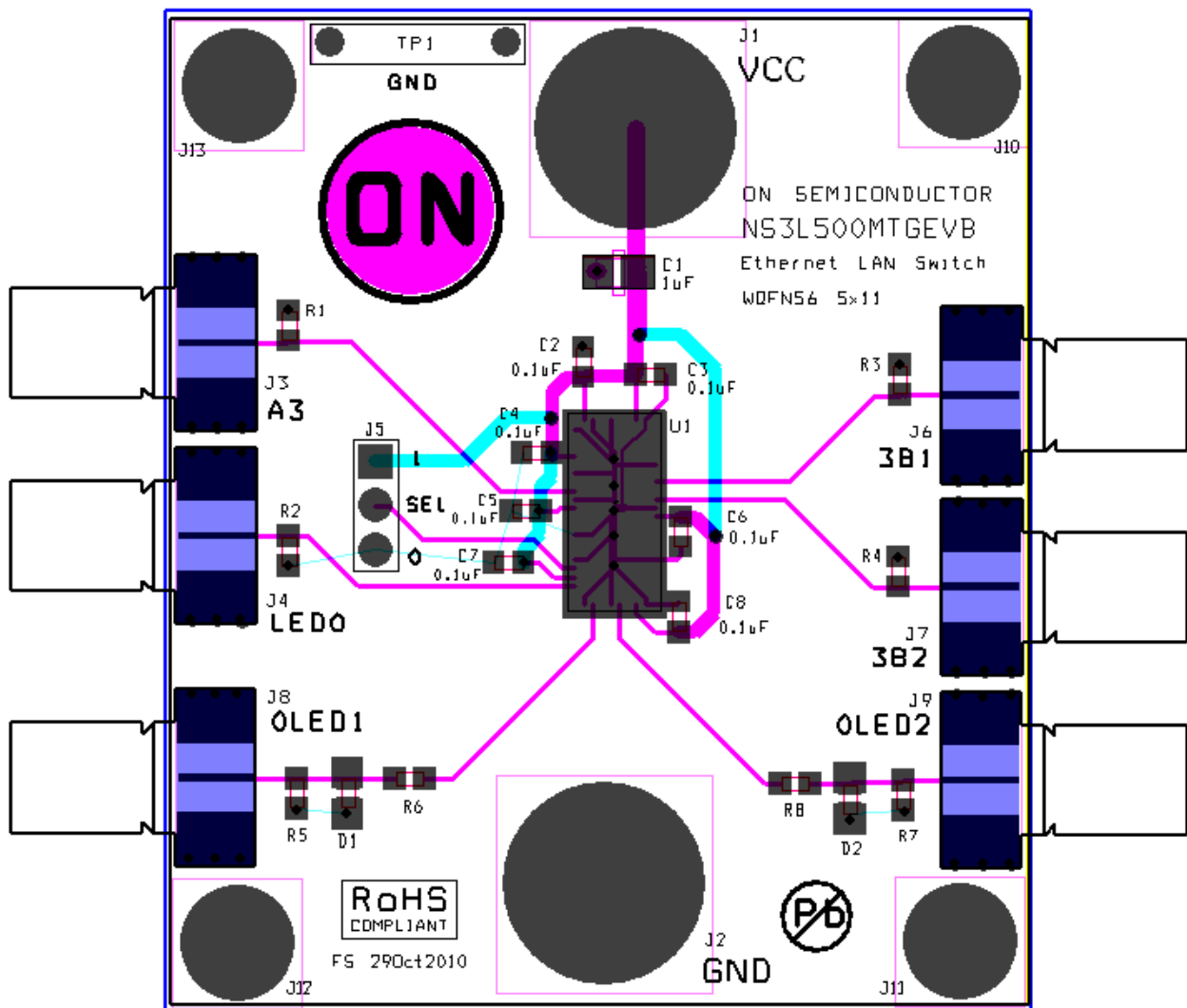

Figure 4. Evaluation Board Layout. Top layer: magenta. Bottom layer: cyan.

NS3L500MTGEVB

Electrical Layout Considerations

Implementing a high speed switch device requires careful PCB design to preserve signal integrity. The evaluation board serves as a layout example and can support the design engineers to preserve high speed performances.

Electrical layout guidelines:

- The bypass capacitor must be placed as close as possible to the Vcc input pin for noise immunity.
- The characteristic impedance of each segment must be 50 Ω single-ended and 100 Ω differential according to IEEE standard 802.3.
- The ground plane of the PCB will be used to determine the characteristic impedance of each line.
- All corresponding differential A+/- line segment pairs must be the same length.
- The use of vias to route these signals should be avoided when possible.
- The use of turns or bends to route these signals should be avoided when possible. When bends are needed, use 45° bends instead of 90° bends.

ON Semiconductor and **ON** are registered trademarks of Semiconductor Components Industries, LLC (SCILLC). SCILLC owns the rights to a number of patents, trademarks, copyrights, trade secrets, and other intellectual property. A listing of SCILLC's product/patent coverage may be accessed at www.onsemi.com/site/pdf/Patent-Marking.pdf. SCILLC reserves the right to make changes without further notice to any products herein. SCILLC makes no warranty, representation or guarantee regarding the suitability of its products for any particular purpose, nor does SCILLC assume any liability arising out of the application or use of any product or circuit, and specifically disclaims any and all liability, including without limitation special, consequential or incidental damages. "Typical" parameters which may be provided in SCILLC data sheets and/or specifications can and do vary in different applications and actual performance may vary over time. All operating parameters, including "Typicals" must be validated for each customer application by customer's technical experts. SCILLC does not convey any license under its patent rights nor the rights of others. SCILLC products are not designed, intended, or authorized for use as components in systems intended for surgical implant into the body, or other applications intended to support or sustain life, or for any other application in which the failure of the SCILLC product could create a situation where personal injury or death may occur. Should Buyer purchase or use SCILLC products for any such unintended or unauthorized application, Buyer shall indemnify and hold SCILLC and its officers, employees, subsidiaries, affiliates, and distributors harmless against all claims, costs, damages, and expenses, and reasonable attorney fees arising out of, directly or indirectly, any claim of personal injury or death associated with such unintended or unauthorized use, even if such claim alleges that SCILLC was negligent regarding the design or manufacture of the part. SCILLC is an Equal Opportunity/Affirmative Action Employer. This literature is subject to all applicable copyright laws and is not for resale in any manner.

PUBLICATION ORDERING INFORMATION

LITERATURE FULFILLMENT:

Literature Distribution Center for ON Semiconductor
P.O. Box 5163, Denver, Colorado 80217 USA
Phone: 303-675-2175 or 800-344-3860 Toll Free USA/Canada
Fax: 303-675-2176 or 800-344-3867 Toll Free USA/Canada
Email: orderlit@onsemi.com

N. American Technical Support: 800-282-9855 Toll Free
USA/Canada
Europe, Middle East and Africa Technical Support:
Phone: 421 33 790 2910
Japan Customer Focus Center
Phone: 81-3-5817-1050

ON Semiconductor Website: www.onsemi.com

Order Literature: <http://www.onsemi.com/orderlit>

For additional information, please contact your local Sales Representative