

WSG Series of Intelligent Servo-Electric Grippers

Scripting Reference Manual

Firmware Version 2.4.3

January 2013

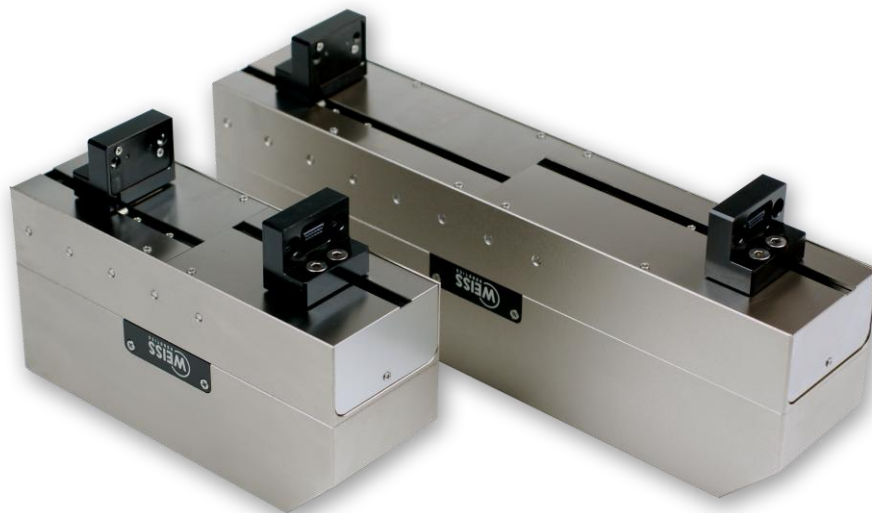



Contents

1	Introduction	5
1.1	The LUA Scripting Language	5
1.2	The Scripting Environment.....	5
1.2.1	Using the Interactive Script Editor.....	5
1.2.2	Uploading and downloading scripts	7
1.2.3	Automatically run a script on startup.....	7
1.2.4	Accessing files from within a script	9
1.2.5	Restrictions	9
2	WSG-specific script extensions	10
2.1	Generic Extensions	10
2.1.1	Error codes	10
2.1.2	Print a formatted string - printf()	10
2.1.3	Wait some time - sleep()	11
2.1.4	Convert bytes into a LUA number - bton()	11
2.1.5	Convert LUA number into bytes - ntob()	12
2.1.6	Convert an error code into a string – etos().....	12
2.1.7	Convert an error code into bytes – etob().....	13
2.1.8	Replace characters inside a string – replace()	13
2.2	System	14
2.2.1	Get system information - system.info()	14
2.2.2	Device tag - system.tag()	15
2.2.3	Get the service tag - system.servicetag()	15
2.2.4	Get temperature - system.temperature()	16
2.3	Gripper state and device information.....	16
2.3.1	Read system state flags - gripper.state().....	16
2.3.2	Get the system state as table - gripper.flags()	17
2.3.3	Get gripper limits - gripper.limits().....	18
2.4	General purpose I/O (GPIO)	18
2.4.1	Access a single pin - gpio.pin().....	19
2.4.2	Set an output pin to high - gpio.set()	19
2.4.3	Set output Pin to low - gpio.clear().....	20
2.4.4	Access I/O pins directly - gpio.pins()	20



2.5	Motion Control.....	21
2.5.1	Speed controller gain - mc.pid()	21
2.5.2	Position controller gain - mc.kv()	22
2.5.3	Finger speed - mc.speed()	22
2.5.4	Finger opening width - mc.position()	23
2.5.5	Get block - mc.blocked().....	24
2.5.6	Current grasping force and force limit - mc.force().....	24
2.5.7	Get approximated grasping force - mc.aforce()	25
2.5.8	Tare force sensors - mc.tare()	25
2.5.9	Finger acceleration limit - mc.acceleration().....	26
2.5.10	Set soft limits - mc.softlimits().....	27
2.5.11	Enable soft limits - mc.softlimits_en().....	28
2.5.12	Soft limits reached - mc.softlimits_reached()	29
2.5.13	Stop current movement - mc.stop().....	29
2.5.14	Are the fingers moving? - mc.busy().....	30
2.5.15	Move fingers - mc.move()	30
2.5.16	Move fingers using a ramp profile – mc.move_ramp().....	32
2.5.17	Move fingers using a rectangular profile – mc.move_rect()	33
2.5.18	Stop in case of an error - mc.faststop()	33
2.5.19	Execute custom trajectory - mc.trajectory()	34
2.5.20	Execute homing sequence - mc.homing()	35
2.6	Grasping.....	36
2.6.1	Grasp a part - grasping.grasp()	36
2.6.2	Release a part - grasping.release()	37
2.6.3	Manually clamp a part - grasping.clamp().....	38
2.6.4	Manually stop clamping a part - grasping.stop_clamping()	40
2.6.5	Get grasping state - grasping.state()	40
2.6.6	Get grasping state as string – grasping.statestring()	41
2.6.7	Get grasping statistics - grasping.stats().....	42
2.6.8	Reset grasping statistics - grasping.resetstats()	43
2.7	Command Interface	44
2.7.1	Interface – cmd.interface().....	44
2.7.2	Get command statistics – cmd.stats()	44
2.7.3	Host connected? – cmd.online()	45
2.7.4	Register a packet ID – cmd.register()	46
2.7.5	Unregister a packet ID – cmd.unregister()	47



2.7.6	Send a data packet – cmd.send()	47
2.7.7	Get number of available packets – cmd.available()	48
2.7.8	Read a received data packet – cmd.read()	49
2.8	Finger control	50
2.8.1	Get number of fingers – finger.count()	50
2.8.2	Get finger type – finger.type()	51
2.8.3	Get or set a finger parameter – finger.param()	51
2.8.4	Get the current finger data – finger.data()	53
2.8.5	Digital sensor interface – finger.interface()	54
2.8.6	Get finger state – finger.state()	57
2.8.7	Get the finger state as table - finger.flags()	58
2.8.8	Control finger power – finger.power()	59
2.8.9	Get analog voltage – finger.analog()	60
2.8.10	Write data to finger – finger.write()	60
2.8.11	Bytes available – finger.bytes_available()	61
2.8.12	Read data from finger – finger.read()	62
2.8.13	Synchronous data transfer via SPI – finger.spi()	63
2.8.14	Finger configuration memory – finger.config()	64
2.9	Profibus	66
2.9.1	Get connection state – profibus.online()	66
2.9.2	Get bitrate – profibus.bitrate()	67
2.9.3	Access an I/O flag – profibus.flag()	67
2.9.4	Write/read user flags – profibus.flags()	69
2.9.5	Set one or more output flags – profibus.fset()	69
2.9.6	Clear one or more output Flags – profibus.fclear()	70
2.9.7	Wait for activity – profibus.waitact()	71
3	Appendix A: Error Codes	72
4	Appendix B: System State Flags	73
5	Appendix C: Finger State Flags	75
6	Appendix D: Syntax Notation	76



1 Introduction

The WSG family of grippers includes a powerful scripting engine based on the LUA language that enables you to implement application specific behavior of your gripper. The WSG Grippers include the LUA interpreter version 5.1.4.

1.1 The LUA Scripting Language

LUA is a lightweight and extensible configuration language and was developed by a research group around Roberto Ierusalimschy at Pontifical Catholic University of Rio de Janeiro, Brazil in 1993. This manual will not give you a complete introduction in how to program LUA, but will focus on the gripper-specific extensions of the programming language. A good source for learning LUA and for programming examples is the official LUA Website at <http://LUA.org> and the LUA User's website at <http://LUA-users.org>.

In addition, the following books will give you an introduction in the LUA programming language:

For beginners in programming, we recommend this book:

- K. Jung, A. Brown: *Beginning LUA Programming*, 2007, ISBN 0-470-06917-1

If you are already familiar with programming, you may read instead:

- R. Ierusalimschy: *LUA 5.1 Reference Manual*, August 2006, ISBN 85-903798-3-3
- R. Ierusalimschy: *Programming in LUA*, March 2006, ISBN 85-903798-2-5

There is also a German edition of the latter one:

- R. Ierusalimschy: *Programmieren mit LUA*, September 2006, ISBN 3-937514-22-8

1.2 The Scripting Environment

1.2.1 Using the Interactive Script Editor

For developing and testing scripts, the WSG Grippers contain an interactive script editor (see Figure 1) that is accessible over its web interface. It consists of an editor with syntax highlighting and a console window to display log messages from your script. To open the interactive script editor, go to the gripper's website by entering its IP address in your browser's address line. Alternatively, you can use the symbolic name <http://wsg50-00000000.local> of your gripper, replacing the "00000000" by the serial number of your Gripper (this requires mDNS to be enabled on the gripper and an mDNS service like "Bonjour" running on your PC). This 8 digit number can be found on the type label located above the connectors. When accessing the WSG's web interface, you may have to log in first, depending on the security settings of the gripper.



You need administrator rights to use the interactive script editor

Go to the interactive scripting page by choosing “*Scripting -> Interactive Scripting*” from the main menu. You can now either write a new script or load one from the WSG’s SD-Card by pressing the “Open” button. To run a script, it has to be saved first. Select a name that allows an easy identification of the script by its function. The file extension has to be “.lua”. To abort a currently running script, press the “Stop” button. The editor supports common hotkeys, e.g. CTRL-C for copy, CTRL-P for paste and CTRL-S for save.

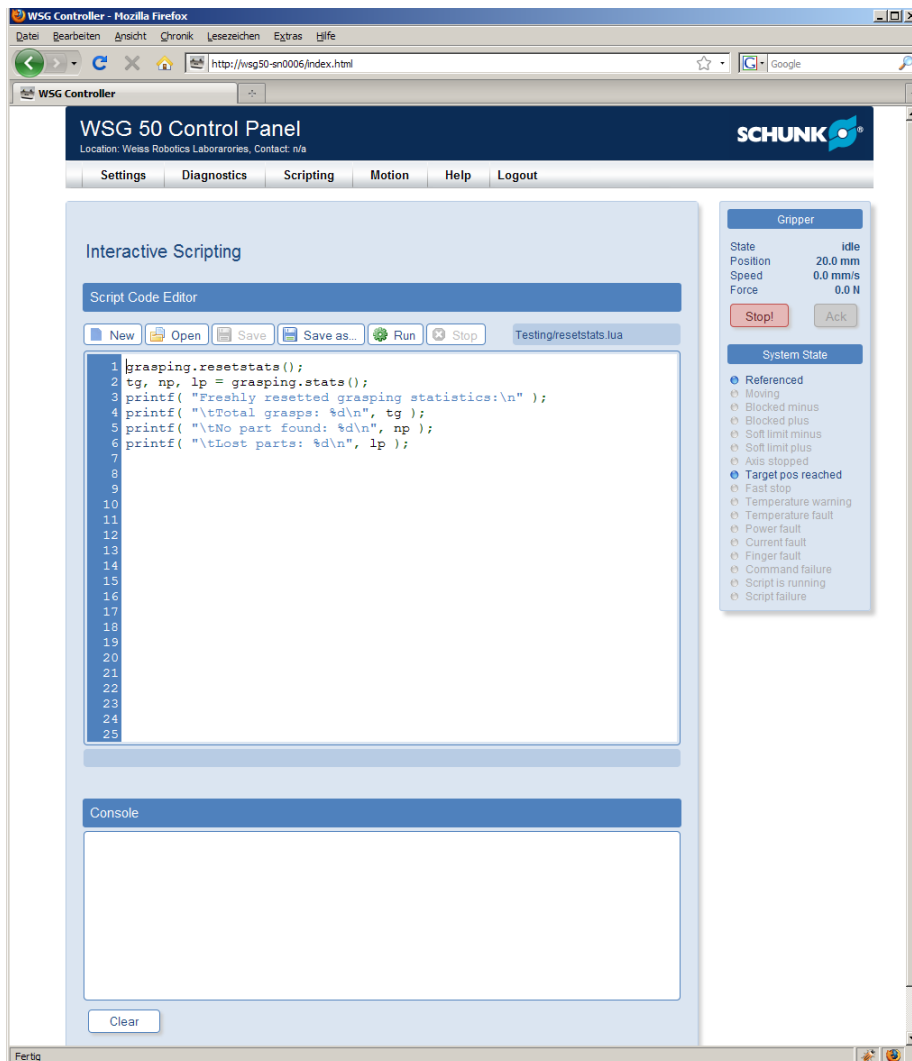



Figure 1: The Interactive Scripting Editor

1.2.2 Uploading and downloading scripts

You can either copy your scripts to the SD card manually by placing the SD card into a compatible reader or you can use the upload feature of the WSG's web interface, see Figure 2.

 **Scripts must be located in the `/user` directory or any subdirectory and must end with `“.lua”` to be started.**

 **You need administrator rights to upload or download scripts**

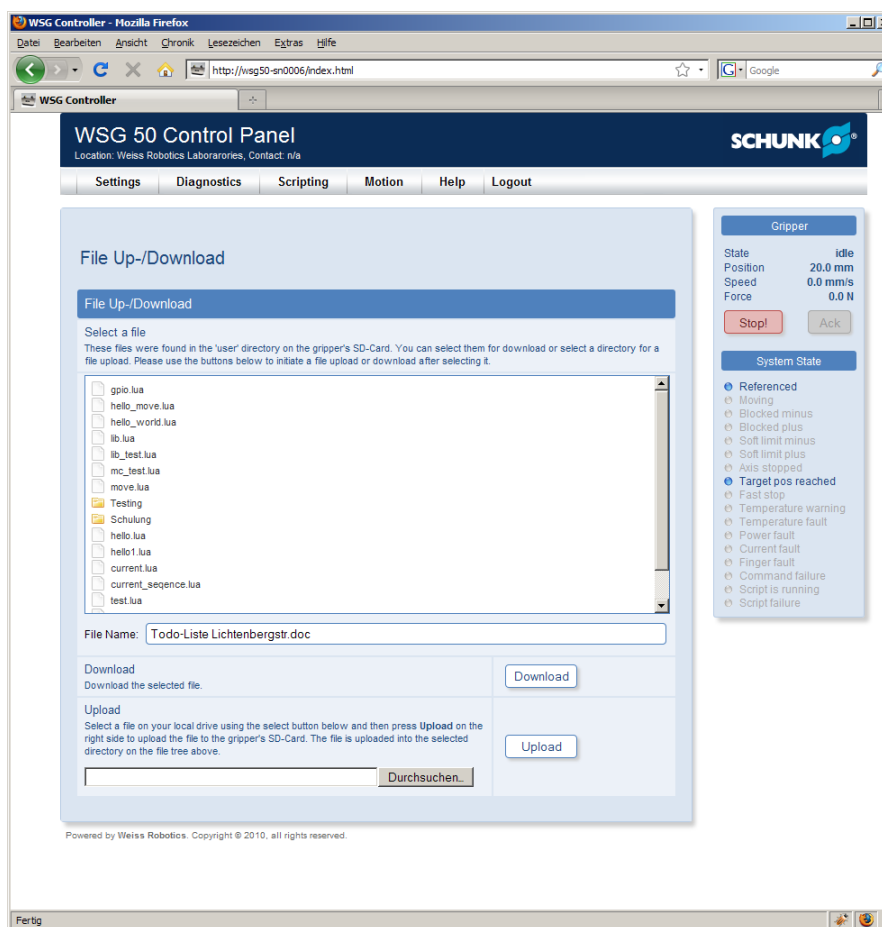

Figure 2: Up-/Download Page

1.2.3 Automatically run a script on startup

Via the web interface of the WSG Gripper (go to the system settings page via *“Settings -> System”*), you may specify any script from the `/user` directory to be automatically executed when the gripper starts up (see Figure 3). Care should be taken that the script runs error-free. It is easy to imagine that you can

seriously disturb the normal operation of the gripper with an erroneous script. We recommend testing the script extensively using the interactive scripting editor before using it as an autorun script.

In autorun mode, all console outputs are discarded, unless you open the web interface and go to the interactive scripting editor page. There, you can see the currently running script.

In case of a script error, a FAST STOP is raised and the error is written to the system log.

 Scripts must be located in the /user directory to be selectable as autostart script.

 You need administrator rights to configure the autostart feature

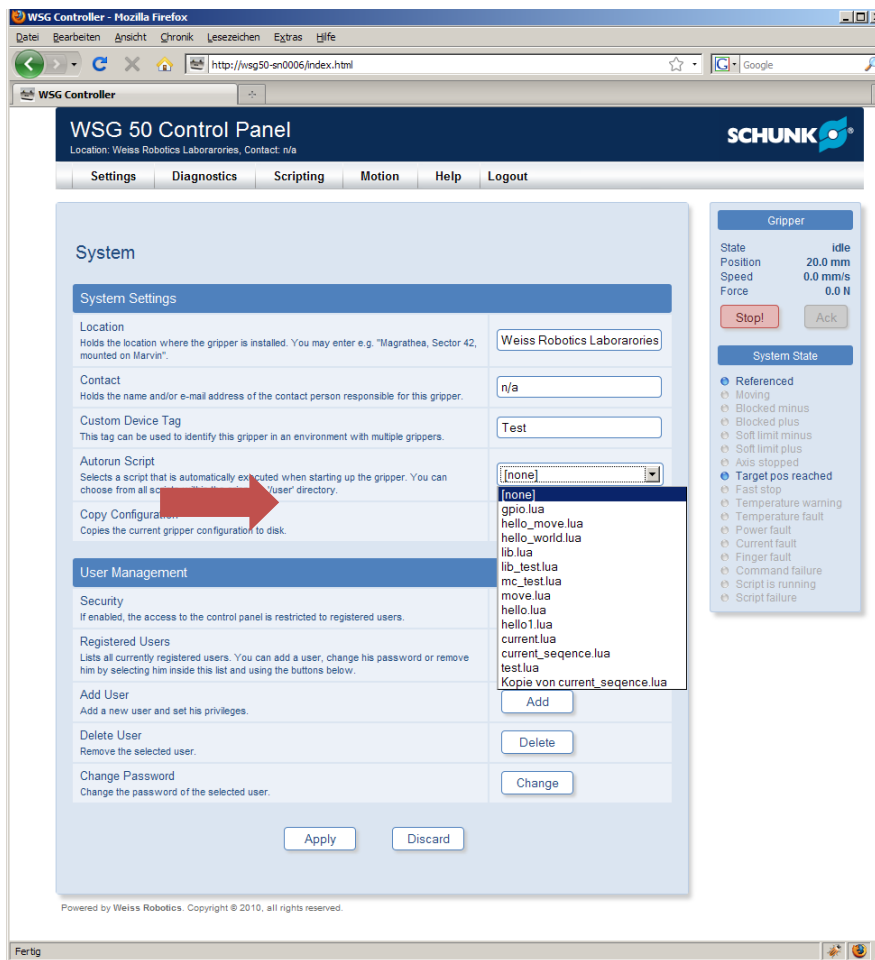

Figure 3: Configuring an autostart script



1.2.4 Accessing files from within a script

You can create and access files on the WSG Gripper's integrated SD card. This may be useful e.g. to store grasping information on different parts that have to be grasped in the same process. The default directory when starting a script is `/user`. To read the content of a file, you can use the example code below. It accesses the file `test.txt` which is assumed to be located in the user directory on the SD card. For a complete "How To" on accessing files from within LUA, please see the LUA Manual at <http://lua.org>.

Example

```
f = assert( io.open("test.txt", "r" ) );
text = f:read( "*all" );
f:close();
print( text );
```



Care should be taken if accessing a file using an absolute path, as manipulation of system-related files (outside the `/user` directory) may endanger the correct operation of the gripper!

1.2.5 Restrictions

Even if the WSG Grippers support the complete functional range and syntax of the LUA programming language, the following restrictions apply when running a script on the gripper hardware:

- Arithmetic calculations are done using single precision floating point functions.
- Environment variables are not available.
- Console buffer does not block if full. Prints to the console (either via "print" or "printf") are internally buffered with a buffer of a constant length. If the script constantly prints messages but they are not polled by a client (i.e. the web interface's console window is not active), the message buffer may discard new messages if it is already full.
- The script cannot read characters from the standard input (e.g. keyboard input).
- If the script was started automatically on startup, a script error will raise a FAST STOP condition and an entry describing the error is created in the system log.



2 WSG-specific script extensions

2.1 Generic Extensions

2.1.1 Error codes

The WSG firmware provides the available error codes as global variables that can be used from within your script. They can be used as a standard variable inside your code, e.g. to print the error number for success to the console, you can simply write `printf("E_SUCCESS = %d\n", E_SUCCESS)`.

Since LUA does not support constants by default, the provided variables can be changed (however this is not a good idea!).

 For a list of the available error codes see [Appendix A \(chapter 2.9\)](#).

2.1.2 Print a formatted string - printf()

Print a formatted string to the console. The format string follows the same rules as the ANSI C `printf()` command. The following options/modifiers are not supported: *, l, L, n, p, h. For further details on formatting strings, see the description of `string.format` in the LUA Reference Manual.

 The console uses line buffering for `printf()` outputs. To force a line to be printed immediately, terminate it using a carriage return (`'\n'`) character.

 The internal buffer of the console output will hold a limited number of characters. If no console window is open or your script prints too much text, this buffer may become full and additional text may be lost!

Syntax

```
printf( fmt, [...] )
```

Parameters

fmt

Format string

... (optional)

Optional list of parameters that are output using the format described in *fmt*.

Return Value



none

Example

```
printf( "Hello World!\n" ); -- outputs "Hello World" at the console
printf( "This is a %s: %d\n", "ten", 10 ); -- outputs "This is a ten: 10" at the console
```

2.1.3 Wait some time - sleep()

Pauses the script execution for a given time.

Syntax

```
sleep( ms )
```

Parameters

ms (integer)

Time to wait in milliseconds. Negative values are treated as 0.

Return Value

none

Example

```
sleep( 1000 ); -- waits for 1 second
```

2.1.4 Convert bytes into a LUA number - bton()

Converts a table with 4 bytes representing an IEEE 754 single precision floating point number into a LUA number.

Syntax

```
<number> = bton( bytes )
```

Parameters

bytes <table>

Table containing four integers in the range of [0..255]. Byte addressing is little endian.

Return Value



floating point number

Example

```
number = hton( {164, 112, 157, 63} );  
printf( "Number is %g\n", number ); -- outputs "Number is 1.23" at the console
```

2.1.5 Convert LUA number into bytes - ntob()

Interprets a LUA number as an IEEE 754 single precision floating point number and converts it into its byte representation.

Syntax

```
<number> = ntob( number )
```

Parameters

number <number>

LUA Floating point number.

Return Value

Returns a table with four integers in the range of [0..255] that holds the binary representation of the passed LUA number.

Example

```
bytes = {};  
bytes = ntob( 1.23 );  
print( bytes ); -- outputs "164 112 157 63" at the console
```

2.1.6 Convert an error code into a string – etos()

Some functions may return a gripper-specific error code as a return value. This function converts the error code into given as parameter into a human readable string. For a list of error codes, see the Appendix A.

Syntax

```
<string> = etos( errorcode )
```

Parameters



errorcode (integer)

Error code.

Return Value

returns a human readable string describing the error.

Example

```
s = etos( E_CMD_FAILED );  
printf( "Error text: %s\n", s ); -- Will output: "Error text: Command failed"
```

2.1.7 Convert an error code into bytes – etob()

Convert the given error code into its two-byte representation as it is used e.g. as a return code for custom commands. The function does not check for the validity of the given error code. For a list of error codes, see the Appendix A.

Syntax

<table> = etob(errorcode)

Parameters

errorcode (integer)

Error code. See Appendix A for a list of error codes.

Return Value

Returns a table containing the two byte values as integer values (range 0..255).

Example

```
-- This will output "Error code bytes: 18, 0" at the console:  
printf( "Error code bytes: %d, %d\n", etob( E_CMD_FAILED ));
```

2.1.8 Replace characters inside a string – replace()

Replace all occurrences of the old character inside a string by a new character.

Syntax

<string> = replace(str, oldch, newch)

Availability



This command is available from firmware version 2.4.0 onwards

Parameters

str (string)

String where the characters should be replaced.

oldch (string)

Character to be replaced. This string must only contain one character.

newch (string)

Replacement character. This string must only contain one character.

Return Value

Returns a copy of the given string where the characters have been replaced.

Example

```
-- Replace all points by commas:  
s = "These are numbers: 1.234 and 3.45";  
print( replace( s, ".", "," )); -- -> produces "These are numbers: 1,234 and 3,45"
```

2.2 System

2.2.1 Get system information - system.info()

Returns a table containing the system information and the gripper-specific physical limits.

Syntax

```
<table> = system.info()
```

Parameters

none

Return Value

Table containing the system information:

<code><table>.serial_number = <int></code>	Serial Number
<code><table>.hw_revision = <int></code>	Hardware revision
<code><table>.sw_revision = <string></code>	Software revision
<code><table>.bl_version = <string></code>	Bootloader version



<code><table>.type = <string></code>	System type, e.g. "WSG 50"
<code><table>.macaddr = <string></code>	The sensor's MAC address

Example

```
info = {};
info = system.info();
printf( "type: %s mm\n", info.type );      -- outputs: "type: WSG 50"
```

2.2.2 Device tag - system.tag()

Sets and/or returns the system tag. The system tag is a string that can be set to any value. You can write e.g. application specific data or the gripper location to it. The system tag can be accessed via the command interface, too.

Syntax

```
<string> = system.tag( [value] )
```

Parameters

value (string), optional

If this parameter is passed, it defines the new value for the tag.

Return Value

Current tag value.

Example

```
system.tag( "Example" );                  -- Set the system tag to "Example"
printf( "System tag is %s\n", system.tag()); -- outputs: "System tag is Example"
```

2.2.3 Get the service tag - system.servicetag()

Return the service tag of the device. The service tag is an alphanumeric string that is used to identify the device for service purposes.

Syntax

```
<string> = system.servicetag()
```

Availability

This command is available from firmware version 2.4.0 onwards

**Parameters**

none

Return Value

String containing the service tag of the device

Example

```
tag = system.servicetag();  
printf("The system service tag is %s\n", tag );
```

2.2.4 Get temperature - `system.temperature()`

Return the temperature of the device.

Syntax

```
<number> = system.temperature()
```

Availability

This command is available from firmware version 2.4.0 onwards

Parameters

none

Return Value

Temperature in degrees celsius

Example

```
t = system.temperature();  
printf("The current system temperature is %f degC\n", t );
```

2.3 Gripper state and device information

2.3.1 Read system state flags - `grripper.state()`

Get the currently set system state flags. A mask can be applied to filter out specific flags. See chapter 4 for the system flags definition.



i If you want to read the system state flags as a table, use `gripper.flags()` instead (see chapter 2.3.2)

Syntax

```
<int> = gripper.state( [mask] )
```

Parameters

mask (integer), optional

If passed, only the system flags that are masked (i.e. set to HIGH) will be returned.

Return Value

Returns the currently set system state flags.

Example 1

```
flags = gripper.state(); -- returns the current system state flags.
```

Example 2

```
if gripper.state( 0x0018 ) then -- Test for the AXIS BLOCKED flags
    printf(" Axis blocked!\n" );
end;
```

2.3.2 Get the system state as table - gripper.flags()

Get the currently set system state flags as an associative table. The flags can be easily accessed by using their symbolic name, see the example below. Chapter 4 lists the symbolic names of the system flags.

i If you want to read the system state flags as an integer value, use `gripper.state()` instead (see Chapter 2.3.1)

Syntax

```
<table> = gripper.flags()
```

Availability

This command is available from firmware version 2.4.0 onwards

Parameters

none

Return Value

Current system state flags as an associative table.



Example

```
flags = gripper.flags(); -- returns the current system state flags.
if flags.SF_AXIS_BLOCKED == true then
    print(" Axis is blocked!" );
else
    print(" Axis is not blocked!" );
end;
```

2.3.3 Get gripper limits - gripper.limits()

Returns a table containing the gripper-specific physical limits.

Syntax

```
<table> = gripper.limits()
```

Parameters

none

Return Value

Table containing the system information:

<code><table>.stroke = <number></code>	Stroke in mm
<code><table>.min_speed = <number></code>	Minimum speed of the gripper in mm/s
<code><table>.max_speed = <number></code>	Maximum speed of the gripper in mm/s
<code><table>.min_acc = <number></code>	Minimum acceleration in mm/s ²
<code><table>.max_acc = <number></code>	Maximum acceleration in mm/s ²
<code><table>.min_force = <number></code>	Minimum grasping force in N
<code><table>.nominal_force = <number></code>	Nominal grasping force in N (duty cycle 100%)

Example

```
info = {};
info = gripper.limits();
printf( "stroke: %d mm\n", info.stroke ); -- outputs: "stroke: 110 mm"
```

2.4 General purpose I/O (GPIO)

Control the GPIO interface of the gripper. The WSG 50 has two channels with one IN and one OUT pin each.



2.4.1 Access a single pin - gpio.pin()

Access a discrete GPIO channel. Used to change the value of a discrete GPIO pin and/or to read the value of the corresponding input pin.

Syntax

```
gpio.pin( index, [state] )
```

Parameters

index (integer)

Index of the channel to be accessed (0..1)

state (boolean), optional

Logic level to be set for the selected OUT pin. If this parameter is not given, the logic level of the OUT pin is not changed. Can be either an integer (0..1) or a boolean value.

Return Value

The function returns the logic level of the channel's IN pin (0 or 1).

Example

```
level = gpio.pin(1);      -- Get the logic level of IN1
gpio.pin(0, 1);         -- Set the logic level of OUT0 to logic HIGH
```

2.4.2 Set an output pin to high - gpio.set()

Produce a HIGH level on the OUT pins. Passing a '1' results in a HIGH level of the resp. OUT pin. Passing '0' has no effect.

Syntax

```
gpio.set( bitvector )
```

Parameters

bitvector (integer)

Integer value, where every bit selects one GPIO channel. state.0 -> OUT0, state.1 -> OUT1, ...

Return Value

none

Example



```
gpio.set(2);  -- Sets OUT1 to logic HIGH. The logic level of OUT0 remains unchanged.  
gpio.set(3);  -- Sets both OUT0 and OUT1 to logic HIGH
```

2.4.3 Set output Pin to low - `gpio.clear()`

Produce a LOW level on the OUT pins. Passing a '1' results in a LOW level of the resp. OUT pin while passing '0' has no effect.

Syntax

```
gpio.clear( bitvector )
```

Parameters

bitvector (integer)

Integer value where every bit selects one GPIO channel. state.0 -> OUT0, state.1 -> OUT1, ...

Return Value

none

Example

```
gpio.clear(1); -- Clear OUT0 and leave OUT1 untouched  
gpio.clear(3); -- Clears both OUT0 and OUT1
```

2.4.4 Access I/O pins directly - `gpio.pins()`

Accesses the GPIO pins directly. This function can be used to write to all OUT pins simultaneously and/or to read from all IN pins.

Syntax

```
<int> = gpio.pins( [bitvector] )
```

Parameters

bitvector (integer), optional

If passed, the OUT pins will be set according to this bit vector. Output is treated as bit vector, where bit 0 corresponds to OUT0 pin, bit 1 to OUT1, etc.

Return Value

Returns the current logic level of the IN pins as a bit vector, where bit 0 represents the logic level of IN0, bit 1 that of IN1, etc.

**Example**

```
levels = gpio.pins();    -- returns 2, if IN1 is HIGH and IN0 is LOW.  
gpio.pins(2);          -- sets OUT0 to LOW and OUT1 to HIGH
```

2.5 Motion Control

2.5.1 Speed controller gain - mc.pid()

Set and get the PID parameters for the speed controller.

 **Incorrect settings of the controller gains may result in swinging of the fingers which can damage the mechanics. Please use this command with care!**

Syntax

```
<number>, <number>, <number> = mc.pid( [new_p, new_i, new_d] )
```

Parameters

new_p (number), optional

New proportional gain for the speed controller. Must be a positive value.

new_i (number), optional

New integral gain for the speed controller. Must be ≥ 0 .

new_d (number), optional

New differential gain for the speed controller. Must be ≥ 0 .

Return Value

The function returns three parameters:

1. currently set proportional gain
2. currently set integral gain
3. currently set differential gain

If new gain values are passed, the function returns these values.

Example

```
p, i, d = mc.pid();    -- stores the current gain values in the variables p, i and d.  
mc.pid( 3.2, 60, 0 ); -- sets the proportional gain to 3.2, integral to 60 and differential to 0
```



2.5.2 Position controller gain - mc.kv()

Set and get the position controller's proportional gain.

 **Incorrect settings of the controller gains may result in swinging of the fingers which can damage the mechanics. Please use this command with care!**

Syntax

```
<number> = mc.kv( [kv] )
```

Parameters

kv (number), optional

New proportional gain for the position controller. Must be a positive value.

Return Value

The function returns the currently set kv value.

Example

```
printf( "Kv is %.2f\n", mc.kv() );  
-- Set kv:  
mc.kv( 13.2 ); -- sets the proportional gain of the position controller to 13.2
```

2.5.3 Finger speed - mc.speed()

Set and/or read back the current speed of the fingers. The speed is measured between the fingers, i.e. a value of 100 mm/s means that every finger moves with 50 mm/s. If a speed value outside the gripper's limits is set, the value is clamped to the limiting value.

The function raises a runtime error, if at least one of the following conditions is met:

- Gripper is in FAST STOP state.
- Gripper is not referenced.

Syntax

```
<number> = mc.speed( [new_speed] )
```

Parameters

new_speed (number), optional

New speed value in mm/s.

Return Value



Returns the current speed of the fingers in mm/s.

Example

```
speed = mc.speed();           -- stores the current finger speed in variable "speed".
mc.speed( 50 );              -- set the finger speed to 50 mm/s
```

2.5.4 Finger opening width - mc.position()

Set and/or read back the current opening width of the fingers. The position value is treated as the opening width of the fingers, i.e. it is measured as the distance between the fingers. If a position outside the gripper's limits is set, the Fingers will move against the resp. mechanical end stop. When setting a new position, the function will block, until movement was finished. The function accepts an optional speed parameter. If not set, the speed value from the last move/position command is used.

The function raises a runtime error, if at least one of the following conditions is met:

- Movement timed out, i.e. the target position was not reached in the calculated time.
- The given position violates the soft limits.
- Gripper is in FAST STOP state.
- Gripper is not referenced.



The force limit for repositioning mode can be set by the `mc.force()` command (see page 24 for details)

Syntax

```
<number> = mc.position( [targetpos], [speed] )
```

Parameters

targetpos (number), optional

New finger opening width in mm.

speed (number), optional

Finger opening speed in mm/s.

Return Value

Returns the current opening width of the fingers in mm.

Example

```
width = mc.position();        -- stores the current opening width of the fingers in variable "width".
mc.position( 50 );           -- set the finger opening width to 50 mm.
```



2.5.5 Get block - mc.blocked()

Get the current blocking state of the fingers.

 The block direction can be obtained from the System Flags.

Syntax

```
<boolean> = mc.blocked()
```

Parameters

none

Return Value

The function returns true, if the fingers are blocked.

Example

```
print( mc.blocked() );           -- print the current blocking state
```

2.5.6 Current grasping force and force limit - mc.force()

The function returns the current grasping force as well as the currently set force limit. If an additional parameter is given, it will set a new force limit for future pre-positioning movements and grasping commands.

 The value set as force limit is lost power-down.

 In prepositioning mode (using mc.position() and mc.move() commands), force always estimated by measuring the motor current. If you want to have true force control using an installed WSG-FMF measurement finger, please use the grasping.grasp() command instead.

Syntax

```
<number>, <number> = mc.force( [forcelimit] )
```

Parameters

forcelimit (number), optional

New force limit in Newton. If you set a value that is outside the gripper's capabilities, it is clamped to the nearest possible value.

Return Value



The function returns two parameters:

1. Current grasping force
2. Force limit value

Example

```
mc.force( 50 );           -- Set the force limit to 50 N
print( mc.force() );     -- print the current grasping force and the force limit
```

2.5.7 Get approximated grasping force - mc.aforce()

The function returns the approximated grasping force computed from the motor current. Especially with force measurement fingers installed, this command is useful to determine any loads that are applied outside the force-sensitive area of the finger.

 **Without force measurement fingers installed, this is same as the grasping force returned by mc.force() (see chapter 2.5.6).**

Syntax

```
<number> = mc.aforce()
```

Availability

This command is available from firmware version 2.0.0 onwards

Parameters

none

Return Value

The function returns the actual approximated force in Newton.

Example

```
f = mc.aforce();
print( "Approximated Force is %.1f N\n", f );    -- print the approximated force
```

2.5.8 Tare force sensors - mc.tare()

Adjusts the force sensor output to zero, hiding any static offset error or initial load condition.

 **Depending on the system settings, the force sensors are automatically zeroed with every homing sequence, too.**

 This command is only allowed, if the gripper is not in force control mode (i.e. the grasping state must not be HOLDING when issuing this command).

Syntax

```
<integer> = mc.tare()
```

Availability

This command is available from firmware version 1.1.0 onwards

Parameters

none

Return Value

The function returns a standard error code as listed in Appendix A:

Example

```
err = mc.tare(); -- Tares the connected force sensing fingers
printf( "Taring done: %s\n", etos( err ) );
```

2.5.9 Finger acceleration limit - mc.acceleration()

The function returns the finger acceleration limit. If a parameter is given, it will set a new acceleration limit for future movements, too. The acceleration limit is the maximum allowed acceleration for the finger movement and is used for all movement-related commands, except STOP and FAST STOP, which stop the axis immediately.

 The value set as acceleration limit is lost power-down.

Syntax

```
<number> = mc.acceleration( [acceleration] )
```

Parameters

acceleration (number), optional

New finger acceleration limit in mm/s². If this value is outside the gripper's capabilities, it is clamped to the nearest possible value.

Return Value

The function returns the currently set acceleration limit.



Example

```
mc.acceleration( 1000 ); -- Set the acceleration to 1000 mm/s2
printf( "Current acceleration limit is %g mm/s2", mc.acceleration() );
```

2.5.10 Set soft limits - mc.softlimits()

The function returns the currently set soft limits. If two parameters are passed, they will be set as new soft limit values and soft limits checking will be enabled automatically. You can only set soft limits in both movement directions. To effectively disable checking in one direction, set its limit to a value that is outside the gripper movement range.

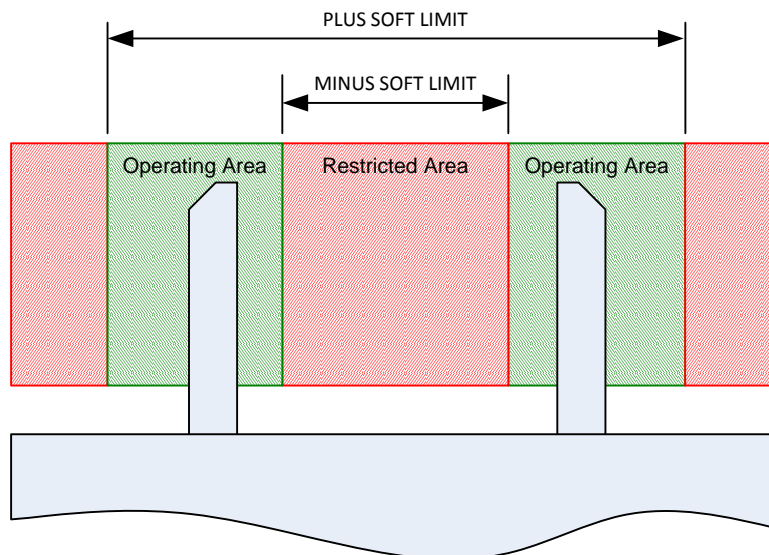

Figure 4: Soft Limits definition

To see if soft limit checking is currently enabled or to enable/disable checking, you may use the *Enable Soft Limits* command, see chapter 2.5.11.

 Any value set by this command is lost at power-down.

Syntax

```
<number>, <number> = mc.softlimits( [minus, plus] )
```

Parameters

minus (number), optional

New soft limit in mm, negative movement direction.



plus (number), optional

New soft limit in mm, positive movement direction.

Return Value

The function returns two parameters (even if soft limit checking is disabled):

1. Currently set limit in mm, negative direction.
2. Currently set limit in mm, positive direction.

Example

```
-- Set new limits:
printf( "Setting negative limit: %.1f mm, positive limit: %.1f mm\n", mc.softlimits( 10, 90 ));
-- Soft limit checking is enabled, now!
end;
```

2.5.11 Enable soft limits - mc.softlimits_en()

The function returns true, if the soft limits are enabled. It can also be used to enable or disable soft limits checking by passing true or false as a parameter to this function. The soft limits have to be set separately using the *Set Soft Limits* command, see chapter 2.5.10.



Any value set by this command is lost at power-down.

Syntax

```
<number> = mc.softlimits_en( [enable] )
```

Parameters

enable (boolean), optional

If set to true, soft limits checking is enabled. On false, it is disabled.

Return Value

The function returns the currently set acceleration limit.

Example

```
if not mc.softlimits_en() then
  -- Currently no soft limits set, so we do it, now:
  printf( "Setting negative limit: %.1f mm, positive limit: %.1f mm\n", mc.softlimits( 10, 90 ));
end;

-- Disable soft limits checking again:
mc.softlimits_en( false );
```

2.5.12 Soft limits reached - mc.softlimits_reached()

The function returns true, if one of the soft limits is violated. If soft limit checking is disabled, the function always returns false.

Syntax

```
<boolean> = mc.softlimits_reached()
```

Parameters

none

Return Value

True, if soft limits are violated.

Example

```
if not mc.softlimits_reached() then
  -- Soft limits not reached:
  printf( "Soft limits are not reached\n" );
end;
```

2.5.13 Stop current movement - mc.stop()

Abort the current movement immediately and disable the position controller. The command sets the E_AXIS_STOPPED system flag. After issuing a stop command, the position controller is disabled, i.e. the fingers can be moved by an externally applied force that is larger than the currently set grasping force limit. The position controller will be enabled again by the next positioning command.

Syntax

```
mc.stop()
```

Parameters

none

Return Value

none

Example

```
mc.move( 10, 100 ); -- Move to 10mm, speed=100mm/s, wait, until target position was reached.
mc.move( 100, 10, 0 ); -- Move to 100mm, speed=10mm/s, 0=return immediately
```

```
sleep( 2000 );  
mc.stop(); -- Stop axis  
mc.force( 0 ); -- Set force limit to minimum value, thus enabling a manual movement of the fingers
```

2.5.14 Are the fingers moving? - mc.busy()

mc.busy() returns true, if the fingers are currently moving. This function is helpful when waiting for the completion of a movement.

Syntax

```
<boolean> = mc.busy()
```

Parameters

none

Return Value

true, if fingers are currently moving or false, if the previously given movement command is already completed.

Example

```
mc.move( 10, 100 );  
mc.move( 100, 10, 0 ); -- Move to 100mm, speed=10mm/s, 0=return immediately  
while mc.busy() do  
    printf( "Current opening width: %.2f mm\n", mc.position() );  
    sleep( 300 );  
end;  
printf( "Done, opening width: %.2f mm\n", mc.position() );
```

2.5.15 Move fingers - mc.move()

Initiate a pre-positioning movement of the fingers. The function is similar to mc.position(), but accepts special flags to control the movement. In addition, the function returns an error code as a result of the movement. The force limit set by mc.force() is used for the movement.

mc.move() uses an acceleration- and jerk-limited speed profile for motion (sin²x profile) as shown below.

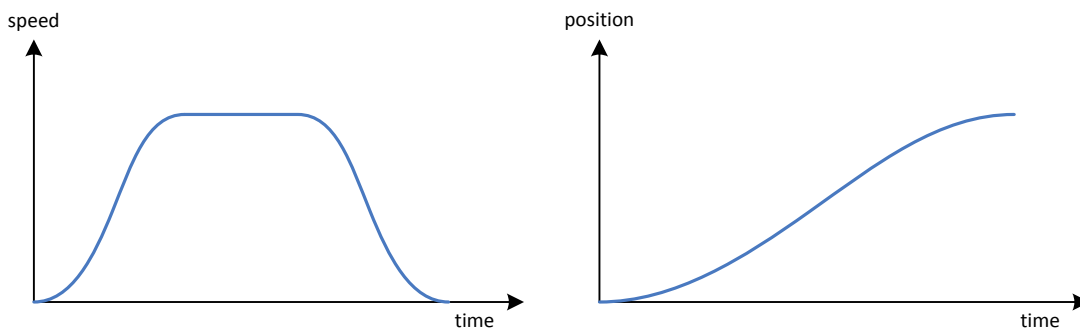

mc.move() raises a runtime error, if at least one of the following conditions is met:

- The given position violates the soft limits.
- Gripper is in FAST STOP state.
- Gripper is not referenced.

i mc.move() is intended to preposition the fingers, not to grasp a part. To grasp a part, please use the grasping.grasp() command instead, since it offers additional features as part detection and monitoring.

i Even with installed force measurement finger (WSG-FMF), prepositioning is always done by approximating the force from the measured motor current, which is not as accurate as the measurement by the force measurement finger.

Syntax

<integer> = mc.move(openingwidth, [speed], [flags])

Parameters

openingwidth (number)

Target opening width of the fingers in mm

speed (number), optional

Positioning speed in mm/s. If not set, the speed from the last move command is taken.

flags (integer), optional

Additional flags to control the movement. If this parameter is not given, flags are treated as PC_WAIT.

Bit No.	Symbol	Description
D31..D3	unused	It is a good practice to set unused flags to 0, since they may be used in future versions.
D2	PC_STOP_ON_BLOCK	If set, a STOP command is issued, if a mechanical block of the fingers was detected.



D1	PC_IGNORE_BLOCK	If set, any mechanical block condition is ignored. In this case, the function returns with a timeout error, if the target position was not reached in a pre-calculated time.
D0	PC_WAIT	If set, the function waits, until the target position was reached or a mechanical block was detected.

Return Value

The function returns an error code describing the movement result. It can be of one of the following values:

E_AXIS_BLOCKED: A block condition occurred while moving (i.e. a part was grasped)

E_TIMEOUT: The target position was not reached in the pre-calculated time.

For further error codes and its meanings, see Appendix A.

Example

```
mc.move( 10, 50 ); -- Move to 10mm, speed=50mm/s, wait until finished
mc.move( 50 );      -- Move to 50mm, speed is still 50mm/s, wait until finished
mc.move( 100, 10, 0 ); -- Move to 100mm, speed=10mm/s, Flags: not set
while mc.busy() do
    printf( "Current opening width: %.2f mm\n", mc.position() );
    sleep( 300 );
end;
printf( "Done, opening width: %.2f mm\n", mc.position() );
```

2.5.16 Move fingers using a ramp profile – mc.move_ramp()

Same as mc.move(), but uses a ramp instead of the \sin^2x profile. This is an acceleration limited speed profile, where a constant acceleration is used to increase and decrease the finger speed. This profile is similar to the \sin^2x -profile, but is not jerk-limited.

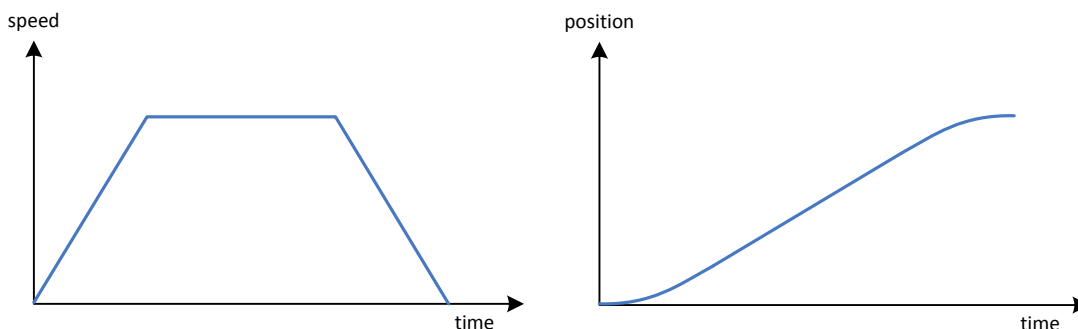

Availability

This command is available from firmware version 2.2.0 onwards



2.5.17 Move fingers using a rectangular profile – mc.move_rect()

Same as mc.move(), but uses a rectangular motion profile. This function is intended e.g. for clamping actions, where the fingers don't have to move but have to apply a preload.

⚠ This speed profile is not acceleration- and not jerk-limited and should be used with care, since it may degrade the mechanical properties of the gripper when used with high speeds and finger loads.

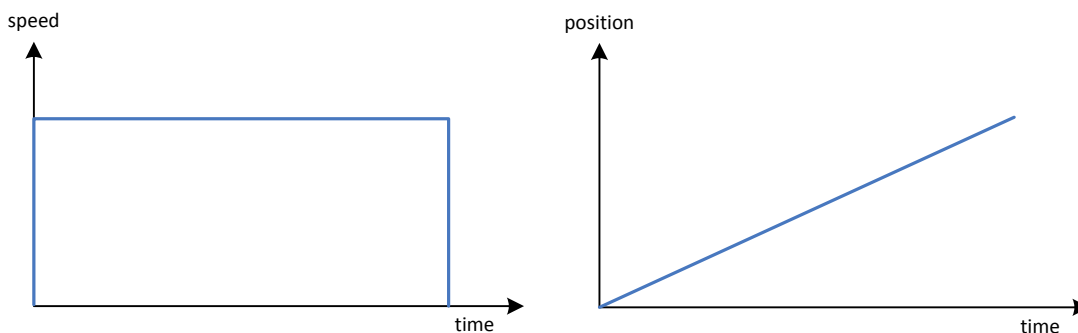

Availability

This command is available from firmware version 2.2.0 onwards

2.5.18 Stop in case of an error - mc.faststop()

Abort the current movement immediately and disable the position controller. A FAST STOP command inhibits any further movement, until the user did acknowledge it. You should only use it to react on a (severe) error condition. Every FAST STOP produces an entry in the system log file. The function can accept a string parameter that is written into the log file, too, to identify the reason of the FAST STOP.

Syntax

```
mc.faststop( [reason] )
```

Parameters

reason (string)

Text string, describing the reason of the FAST STOP.

Return Value

none

Example

```
mc.faststop( "This is a test" );
```



2.5.19 Execute custom trajectory - mc.trajectory()

Execute a trajectory. The trajectory is a sequence of position points that are directly sent to the gripper's interpolation engine. Every interpolation cycle (i.e. every 10 ms), a point is taken from the sequence and used as new target opening width for the fingers. Therefore, the distance between the points determines the moving speed of the fingers. You have to ensure, that the resulting speed becomes not higher than the gripper's maximum speed. The force limit set by mc.force() is applied.

The function will return immediately. Use mc.busy() to wait, until the trajectory execution is finished.

 **The gripper does not test for maximum acceleration when executing a custom trajectory. Your application has to ensure, that speed and acceleration limits of the hardware are not violated.**

The function raises a runtime error, if at least one of the following conditions is met:

- The given position violates the soft limits.
- Gripper is in FAST STOP state.
- Gripper is not referenced.
- The moving speed exceeds the system limits.

Syntax

```
<integer>, <integer> = mc.trajectory( trajectory )
```

Parameters

trajectory (table)

Table containing the position points in mm. The table must only contain numeric values.

Return Value

The function returns two parameters:

1. Error Code. For a list of error codes and their meaning, see Appendix A.
2. Number of processed points

Example



```
t = {};  
len = 200; -- Length of the trajectory is 200 points  
-- Move to start position:  
mc.move( 10, 50 );  
-- Calculate trajectory points:  
pos = mc.position();  
for i=1,len do  
    t[i] = pos + ( math.sin(( i - 1 ) * math.pi / len )^2 * 80 );
```



```
end;
-- Execute trajectory:
error_code, cnt = mc.trajectory( t );
if error_code ~= 0 then
    -- An error occurred:
    printf( "Error while executing: %s. %d points processed.\n", error2str( error_code ), cnt );
else
    -- No error, wait until movement finished:
    while mc.busy() do
        sleep( 50 );
    end;
    printf( "Trajectory executed successfully\n" );
end;
```

2.5.20 Execute homing sequence - mc.homing()

Execute a homing sequence to reference the gripper. During homing, the fingers are moved to one of the mechanical end stops. An optional parameter determines, which end stop is used. The function raises a runtime error, if the gripper is currently in FAST STOP state.

-  **The best positioning performance will be achieved if homing is done into the direction you require the better positioning accuracy.**
-  **Depending on the system settings, the force sensors are automatically zeroed during the homing sequence, too.**

 **During homing, soft limits are disabled!**

 **Obstacles in the movement range of the fingers and collision with these during homing may result in a wrong reference point for the finger position!**

Syntax

```
mc.homing( [direction] )
```

Parameters

direction (boolean), optional

If true, the end stop in positive direction will be used. If set to false, the end stop in negative moving direction will be used. If the parameter is not given, the default end stop is used. You can use the web interface to setup the default value.

Return Value



none

Example

```
mc.homing(); -- homes in the default direction
sleep( 500 );
mc.homing( true ); -- homes towards the positive end stop
sleep( 500 );
mc.homing( false ); -- homes towards the negative end stop
```

2.6 Grasping

2.6.1 Grasp a part - grasping.grasp()

Grasp a part with a given nominal width. As optional parameters, you can pass the finger opening width, traveling speed and the maximum clamping travel.

The function raises a runtime error, if at least one of the following conditions is met:

- Gripper is in FAST STOP state.
- Gripper is not referenced.
- Another movement is currently in progress.



If a force measurement finger (WSG-FMF) is installed on the gripper, the part is grasped using true force control. If no force measurement finger is found, the grasping force is approximated by measuring the motor current. Please note, that this is not as accurate as a direct force measurement.

Syntax

<boolean> = grasping.grasp([width], [speed], [clampingtravel])

Parameters

width (number), optional

Nominal width of the part to be grasped in mm. If not given, the width set by the last call to grasp() is used. Default value on startup is 10 mm.

speed (number), optional

Grasping speed in mm/s. If not given, the speed set by the last call to grasp() is used. Default value on startup is 50 mm/s.

clampingtravel (number), optional

Clamping travel in mm. After touching a part, the gripper tries to establish the grasping force by moving the finger further to the part. This value defines a travel limit for this. If the parameter is not given, the clamping travel set by the last call to `grasp()` is used.

The default value can be set up using the Web Interface (Settings|Motion Configuration -> Default Clamping Travel).

Return Value

Returns true, if a part was grasped (i.e. the grasping state is "holding"). If no part was found or an error occurred, the function returns false.

Example

```
-- Set a grasping force of 10N:
mc.force( 10 );
-- Grasp a part with a nominal width of 10mm, a speed of 50mm and with a
-- max. clamping travel is 5mm:
if grasping.grasp( 10, 50, 5 ) then
    printf( "Part successfully grasped\n" );
else
    printf( "No part grasped\n" );
end;
```

2.6.2 Release a part - grasping.release()

Release a part by opening the fingers. By an optional parameter, you can specify the opening speed.

The function raises a runtime error, if at least one of the following conditions is met:

- Gripper is in FAST STOP state.
- Gripper is not referenced.

Syntax

```
grasping.release( [width], [speed] )
```

Parameters

width (number), optional

Opening width in mm to release the part. If not given, the width set by the last call to `release()` is used. Default value on startup is the gripper's stroke – 5mm.

speed (number), optional



Opening speed in mm/s. If not given, the speed set by the last call to `release()` is used.
Default value on startup is 50 mm/s.

Return Value

none

Example

```
mc.force( 10 ); -- Set Grasping Force to 10N
-- Grasp a part with a nominal width of 10mm and a speed of 50mm. Max. Clamping travel is 5mm:
while not grasping.grasp( 10, 50, 5 ) do
    printf( "No part grasped - trying again...\n" );
    sleep( 500 );
    grasping.release( 30, 100 );
    sleep( 2000 );
end;
printf( "Part successfully grasped\n" );
```

2.6.3 Manually clamp a part - grasping.clamp()

This command can be used to manually clamp a part with a defined grasping force and a defined clamping travel. Since the speed cannot be set with this command, the gripper's fingers should already touch the part. Finger prepositioning can be realized e.g. using a `mc.move()` command (see chapter 2.5.15). The clamping travel is the way, the fingers will move towards the part to establish the specified clamping force. If the fingers can move further than given the clamping travel, the gripper stops and the grasping state is set to "PART LOST".

Note that the axis must already be blocked by the part to be grasped. Else, the command will fail.



Once initiated the clamping of a part manually, you need to stop clamping using the `grasping.release()` or `grasping.stop_clamping()` command (see chapters 2.6.2 and 2.6.4) prior the issuing of another movement command.

Syntax

```
grasping.clamp( travel, force )
```

Availability

This command is available from firmware version 1.2.0 onwards

Parameters

travel (number)



Clamping travel width in mm. Measured between the two fingers (i.e. every finger will move at most half this value). Must be a positive value. The clamping direction will be detected automatically from the block direction.

force (number)

Clamping force in N.

Return Value

none

Example

```
force_threshold = 2.0; -- Force threshold in N to detect a part

-- Make sure a WSG-FMF force measurement finger is installed
if finger.type(0) ~= FT_FMF then
    printf( "Finger 0 is not a force measurement finger\n" );
    return;
end;

mc.homing(); -- Home the gripper
mc.force( 30 ); -- Set force limit (high enough to allow a smooth movement)
mc.move( 10, 50, 0 ); -- Move towards the center to grasp a part

-- Wait, until we touched something:
while ( mc.busy() and ( finger.data(0) < force_threshold )) do
    sleep( 1 );
end;

-- Clamp the touched part:
grasping.clamp( -5, 5 ); -- for the WSG 50, the minimum grasping force is 5N!
printf( "Holding\n" );
while ( mc.busy() ) do
    sleep( 100 );
end;
printf( "bye!\n" );

-- Stop clamping:
grasping.stop_clamping();
```



2.6.4 Manually stop clamping a part - grasping.stop_clamping()

Stop clamping a part after issuing a grasping.grasp() or grasping.clamp() command. This command simply stops the force control without opening the fingers. This function will set the grasping state to IDLE.

Syntax

```
grasping.stop_clamping()
```

Availability

This command is available from firmware version 1.2.0 onwards

Parameters

none

Return Value

none

Example

```
mc.force( 10 ); -- Set Grasping Force to 10N

if grasping.grasp( 10, 50, 15 ) then -- Grasp a part with 10 mm width and a force of 15 N
    printf( "Part successfully grasped\n" );
    sleep( 3000 );

    -- Stop clamping:
    grasping.stop_clamping();
end;
```

2.6.5 Get grasping state - grasping.state()

Returns the current grasping state.

Syntax

```
<integer> = grasping.state()
```

Parameters

none

Return Value

Integer value holding the current grasping state. The grasping state can have one of the following values:



Value	Symbol	Description
0	GS_IDLE	Gripper is in idle state, i.e. it is not holding a part.
1	GS_GRASPING	The fingers are currently closing to grasp a part. The part has not been grasped, yet
2	GS_NO_PART	The fingers have been closed, but no part was found at the specified nominal width. This state will be active until the next grasp or release command is issued.
3	GS_PART_LOST	A part was grasped but then lost before the fingers have been opened again. This state will be active until the next grasp or release command is issued.
4	GS_HOLDING	A part was grasped successfully and is now being hold with the grasping force.
5	GS_RELEASING	The fingers are currently opening towards the opening width to release a part.
6	GS_POSITIONING	The fingers are currently pre-positioned using a “move” command.
7	GS_ERROR	An error occurred.

Example

```
state = grasping.state();
if state == 4 then
    printf( "Holding a part\n" );
else
    printf( "No part!\n" );
end;
```

2.6.6 Get grasping state as string – grasping.statestring()

Returns the current grasping state as a human-readable string.

Syntax

```
<string> = grasping.statestring()
```

Parameters

none

Return Value



String describing the current grasping state:

State	Return value	Description
GS_IDLE	"idle"	Gripper is in idle state, i.e. it is not holding a part.
GS_GRASPING	"grasping"	The fingers are currently closing to grasp a part. The part has not been grasped, yet
GS_NO_PART	"no part"	The fingers have been closed, but no part was found at the specified nominal width. This state will be active until the next grasp or release command is issued.
GS_PART_LOST	"part lost"	A part was grasped but then lost before the fingers have been opened again. This state will be active until the next grasp or release command is issued.
GS_HOLDING	"holding"	A part was grasped successfully and is now being hold with the grasping force.
GS_RELEASING	"releasing"	The fingers are currently opening towards the opening width to release a part.
GS_POSITIONING	"positioning"	The fingers are currently pre-positioned using a "move" command.
GS_ERROR	"error"	An error occurred.

Example

```
grasping.grasp( 10 );
printf( "Current grasping state is '%s'\n", grasping.statestring() );
```

2.6.7 Get grasping statistics - grasping.stats()

Get the current grasping statistics.

Syntax

```
<integer>, <integer>, <integer> = grasping.stats()
```

Parameters

none

Return Value

The function returns three parameters:



1. *Number of total grasps.*

This counter is incremented whenever a grasp command is executed and returned with an error code of E_SUCCESS or E_CMD_FAILED

2. *Number of grasps where no part was found.*

This counter is incremented whenever a grasp commands doesn't find a part at the given nominal width, i.e. returns with E_CMD_FAILED.

3. *Number of lost parts.*

This counter is incremented, if a part was successfully grasped, but removed from in between of the fingers before a release command was given.

Example

```
-- do some grasping...
for i=1,10 do
    grasping.grasp();
    sleep( 500 );
    grasping.release( 20 );
end;
-- get grasping statistics:
tg, np, lp = grasping.stats();
printf( "Current grasping statistics:\n" );
printf( "\tTotal grasps: %d\n", tg );
printf( "\tNo part found: %d\n", np );
printf( "\tLost parts: %d\n", lp );
```

2.6.8 Reset grasping statistics - grasping.resetstats()

Reset the grasping statistics. All counters are set to 0.

Syntax

```
grasping.resetstats()
```

Parameters

none

Return Value

none

Example

```
grasping.resetstats();
tg, np, lp = grasping.stats();
```



```
printf( "Freshly resetted grasping statistics:\n" );  
printf( "\tTotal grasps: %d\n", tg );  
printf( "\tNo part found: %d\n", np );  
printf( "\tLost parts: %d\n", lp );
```

2.7 Command Interface

2.7.1 Interface – cmd.interface()

Get the currently used command interface or to change it. When changing to a connection-based interface, you may want to ensure that the connection is established by using the cmd.connected() command.

Syntax

```
<string> = cmd.interface( [name] )
```

Availability

This command is available from firmware version 1.3.0 onwards

Parameters

name (string), optional

Name of the interface to be used for commands. Possible string values are: “none”, “RS232”, “CAN”, “TCP”, “Profibus”. The name evaluation is not case sensitive.



Depending on the hardware platform you are using, not all of these interfaces might be available.

Return Value

String descriptor for the currently used interface (e.g. “CAN”)

Example

```
printf( "Current Interface is %s\n", cmd.interface() );  
iface = cmd.interface( "can" ); -- changing interface to CAN-Bus  
printf( "Interface changed to %s\n", iface );
```

2.7.2 Get command statistics – cmd.stats()

Read the command interface statistics. They give you detailed information on the health of your high level communication with the gripper.

**Syntax**

```
<table> = cmd.stats()
```

Parameters

none

Return Value

The function returns a table with the following predefined fields:

- **rx_count**
Number of successfully received data packets.
- **checksum_errs**
Counts the checksum errors in received data packets
- **length_errs**
Counts the number of data packets that are too long to be accepted (the gripper accepts payloads with a length of up to 1024 bytes)
- **timeout_errs**
Number of timeout errors. A timeout error occurs, if the time between two received bytes of a packet is larger than 300ms.
- **unknown_id_errs**
Number of received command packets with an unknown ID.
- **tx_count**
Number of successfully transmitted packets.

Example

```
stats = cmd.stats();
printf( "Command statistics:\n" );
printf( "\tReceived Packets: %d\n", stats.rx_count );
printf( "\tRx checksum errors: %d\n", stats.checksum_errs );
printf( "\tRx length errors: %d\n", stats.length_errs );
printf( "\tRx timeout errors: %d\n", stats.timeout_errs );
printf( "\tRx unknown IDs: %d\n", stats.unknown_id_errs );
printf( "\tSent packets: %d\n", stats.tx_count );
```

2.7.3 Host connected? – cmd.online()

Returns true, if a host is connected via the specified command interface. This command will only be useful on TCP and Profibus connections. On communication via CAN-Bus and RS232, the host is assumed to be always connected.

**Syntax**

```
<Boolean> = cmd.online()
```

Parameters

none

Return Value

The function returns true, if a host is connected or false, if not. For RS232 and CAN-Bus, the function returns always true.

Example

```
if cmd.online() then
    printf( "Currently online!\n" );
    -- Send a message:
    cmd.register( 0xBB );
    cmd.send( 0xBB, "This is a test!" );
else
    printf( "offline\n" );
end;
```

2.7.4 Register a packet ID – cmd.register()

Register a custom packet ID to send and receive data packets via the command interface. The function raises a runtime error, if you try to register an ID that is already used, e.g. by the built-in command set.

Syntax

```
cmd.register( id )
```

Parameters

id (integer)

Packet ID to be registered. Valid ID values are from 0 to 255.

Return Value

none

Example

```
id = 0xBB;
cmd.register( id );           -- Register ID BBh
cmd.send( id, "This is a test!" );  -- Send a message to the connected host via this Id
```



2.7.5 Unregister a packet ID – cmd.unregister()

Unregister a previously registered custom packet ID.

 You cannot unregister an ID of a built-in command.

Syntax

```
cmd.unregister( id )
```

Parameters

id (integer)

Packet ID to be unregistered. Valid ID values are from 0 to 255.

Return Value

none

Example

```
id = 0xBB;
cmd.register( id );           -- Register ID BBh
cmd.send( id, "This is a test!" ); -- Send a message to the connected host via this Id
cmd.unregister( id );       -- Un-register ID BBh
cmd.send( id, "I will produce an error!" ); -- This line will raise a runtime error!
```

2.7.6 Send a data packet – cmd.send()

Send a data packet using a custom ID. The ID that is used for sending the packet has to be registered before using `cmd.register()` (see chapter 2.7.4). The payload of the data packet is passed as a variable argument list that can contain integer types, Boolean types and string types and well as tables containing these types.

The following conversion rules will be applied:

- Integer and Number types are treated as single bytes, i.e. have a valid range of 0 to 255. If this range is exceeded, the function raises a runtime error. To send a number value, use the `ntob()` conversion function (see chapter 2.1.5).
- Boolean values are converted into a single byte set to 0 and 1, respectively.
- String values are converted into a sequence of bytes (without a trailing zero).
- Tables can contain the above types and can be nested at a total of up to 5 levels.

 The maximum length for a custom command is 65536 bytes.

 Trying to send a packet while the connection is offline will produce a runtime error.

Syntax



```
cmd.send( id, [...] )
```

Parameters

id (integer)

Packet ID. Valid ID values are from 0 to 255.

..., optional

Variable argument list with one or more integer parameters (range: 0 to 255) forming the payload of the data packet. See the description above.

Return Value

none

Example

```
id = 0xBB;
cmd.register( id );    -- Register ID BBh
if cmd.online() then
  -- String payload:
  cmd.send( id, "This is a test!" );
  -- Number as payload:
  cmd.send( id, ntob( 1.234 ) );
  -- Payload combining various types:
  cmd.send( id, 0x54, 0x68, "is is a test!", {1, 2, 3}, {4, 5, ntob(6.7)}, { "Nested Table" } );
  -- Payload with nested tables:
  cmd.send( id, {1, 2, { 3, 4, { 5, 6, { 7, 8, { 9, 10 } } } } } );
else
  printf( "Sorry, currently offline!\n" );
end;
```

2.7.7 Get number of available packets – cmd.available()

Returns the number of received data packets waiting in the input buffer for being read.

 If the connection is currently offline, cmd.available() returns always 0.

Syntax

```
<integer> = cmd.available()
```

Parameters

none



Return Value

The function returns the number of data packets waiting in the reception buffer.

Example

```
cmd.register( 0xBB );      -- Register ID BBh
cmd.register( 0xBC );      -- Register ID BCh
cmd.register( 0xBD );      -- Register ID BDh
while cmd.online() do
  if cmd.available() > 0 then
    id, payload = cmd.read();
    printf( "Data packet received: ID=%d, payload length=%d\n", id, #payload );
  end;
end;
```

2.7.8 Read a received data packet – cmd.read()

To receive data packets with a certain ID, you have first to register this ID by calling `cmd.register()`, see chapter 2.7.4. You can only receive data packets which IDs are not used by the integrated command set. `cmd.read()` blocks, until a data packet was received. You can poll the state of the receive buffer by using `cmd.available()`, see chapter 2.7.7.

 The payload length for received messages is limited to 1024.

Syntax

```
<integer>, <table> = cmd.read()
```

Parameters

none

Return Value

The function returns two parameters:

1. ID of the received data packet (range: 0 to 255)
2. Table containing the payload as consecutive bytes. If the received packet has no payload, the function returns an empty table.

Example

```
-- This example implements a custom command (ID=0xBB) to set the GPIO's output pins
cmd.register( 0xBB );      -- Register ID BBh
while true do
  if cmd.online() then
```



```
id, payload = cmd.read();
if #payload == 1 then
    -- Payload length is okay:
    printf( "Setting outputs to %d\n", payload[1] );
    gpio.pins( payload[1] );
    cmd.send( id, etob( E_SUCCESS )); -- Send E_SUCCESS as return value
else
    -- Error: Payload length mismatch:
    printf( "Payload length mismatch (%d)\n", #payload );
    cmd.send( id, 15, etob( E_CMD_FORMAT_ERROR )); -- Send E_CMD_FORMAT_ERROR as return value
end;
else
    -- Interface is offline...
    sleep( 50 );
end;
end;
```

2.8 Finger control

The Finger Module is used to control and communicate with active fingers connected to the sensor port of the WSG Gripper's base jaws. In contrast to the Lua standard, finger numbering starts at 0, i.e. WSG Grippers with two fingers uses the indices 0 and 1.

2.8.1 Get number of fingers – `finger.count()`

Get the number of available fingers. For the WSG, this is always 2.

Syntax

```
<integer> = finger.count()
```

Parameters

none

Return Value

Number of fingers.

Example

```
printf( "This gripper has %d fingers\n", finger.count() );
```



2.8.2 Get finger type – `finger.type()`

Get the type of the finger with the given index. There are three finger types supported:

- “generic”
This finger type has no predefined function and can be fully controlled by the script.
- “fmf”
Force Measurement Finger. Used by the gripper to control the grasping force. Accessing the finger via `finger.param()` and `finger.data()`.
- “dsa”
Tactile Sensing Finger. Accessing the finger via `finger.param()` and `finger.data()`.

 **The finger types are registered as global variables on startup and can be directly used from inside your script, please see the example below.**

Syntax

```
<string> = finger.type( index )
```

Availability

Syntax changed in firmware version 2.3.0 onwards

Parameters

index (integer)

Finger index. Range is `0..finger.count()-1`.

Return Value

Returns the finger type as string.

Example

```
for i=0,finger.count()-1 do
  t = finger.type(i);
  printf( "Finger %d is a %s finger\n", i, t );
end;
```

2.8.3 Get or set a finger parameter – `finger.param()`

Predefined finger types may have one or more finger-specific parameters that can be set or read using this command.

 **For the finger-specific parameters please refer to the finger’s User Manual.**

**Syntax**

```
<var> = finger.param( index, descr, [value] )
```

Availability

This command is available from firmware version 2.3.0 onwards

Parameters*index (integer)*

Finger index. Range is 0..finger.count()-1.

descr (string)

Descriptor for the parameter. See the list of available parameters in the finger's User Manual.

value (type depending on the parameter), optional

If given, the parameter is changed to this value. The variable type depends on the parameter and is listed in the finger's User Manual.

Return Value

Returns the current value of the parameter. The type depends on the parameter and is listed in the finger's User Manual.

Example

```
-- This example prints some information about the connected
-- Tactile Sensing finger(s)

for i=0,finger.count()-1 do
  if finger.type( i ) == "dsa" then
    -- This is a tactile sensing finger
    controllerType = finger.param( i, "dsatype" );
    version = finger.param( i, "version" );
    cellsX = finger.param( i, "cells_x" );
    cellsY = finger.param( i, "cells_y" );
    width = finger.param( i, "width" );
    height = finger.param( i, "height" );

    printf( "Transducer type: %s (software V%s)\n", controllerType, version );
    printf( "Matrix has %d x %d sensor cells ", cellsX, cellsY );
    printf( "and has an active area of %.1f x %.1f mm\n", width, height );
  end;
end;
```



2.8.4 Get the current finger data – `finger.data()`

Read the current data from a predefined finger. It returns a single value whose format depends on the finger type. This command is only available for fingers of predefined type.

The command will raise a runtime error, if

- you try to access a generic finger
- you try to access an unpowered finger or a finger with a communication error indicated in the finger flags.



For the finger-specific parameters please refer to the finger's User Manual.

Syntax

```
<var> = finger.data( index )
```

Availability

This command is available from firmware version 2.3.0 onwards

Parameters

index (integer)

Finger index. Range is 0..`finger.count()`-1.

Return Value

Returns the current data from the selected finger. Only one value is returned, but its type depends on the finger type. The returned data is described in the finger's User Manual.

Example

```
-- This example tries to read the finger data
-- and print it to the console output

-- Determines the data type and print it:
function printData( m )
    local x, y;
    if type( m ) == "table" then

        -- This is a WSG-DSA frame:
        printf( "Timestamp: %d\n", m.timestamp );
        -- data is a matrix:
        for y=1,#m.frame[1] do
            for x=1,#m.frame do
                printf( "%4d ", m.frame[x][y] );
            end;
        end;
    end;
end;
```



```

        printf( "\n" );
    end;
else
    -- data is a scalar value (e.g. WSG-FMF):
    printf( "%.1f\n", m );
end;
end;

-- Read data from all fingers that support it:
for i=0,1 do
    printf( "Finger %d (%s)\n", i, finger.type(i) );
    res, data = pcall( finger.data, i );
    if res == true then
        printData( data );
        printf( "\n" );
    else
        printf( "Finger doesn't provide any data\n" );
    end;
end;
end;

```

2.8.5 Digital sensor interface – `finger.interface()`

Get or configure the digital sensor interface inside the gripper's base jaw that is used to communicate with a custom finger electronics. This command allows to set up the communication type (SPI or UART), as well as other interface settings like bit rate, frame size, clocking polarity and phasing (SPI).

The current interface settings can be obtained by using this function without any of the optional parameters (e.g. `finger.interface(0)` for finger 0).

 **Setting the interface configuration is only possible for generic fingers.**

Syntax

```
<string> = finger.interface( index, [ifacetype], [bitrate], [framesize], [CPOL], [CPHA] )
```

Availability

Configuring the interface is available from firmware version 2.0.0 onwards

Parameters

index (integer)

Finger index. Range is `0..finger.count()-1`.



*ifacetype (string), optional**

String describing the new interface to be used. Valid descriptors are

- “spi” for SPI interface
- “uart” for UART interface
- “none” to disable the interface.

*bitrate (integer), optional**

Bit rate of the interface in Bits per second.

For SPI connections: available bitrates can be determined using the following formula ($n=0..255$):

 **If a bit rate is set that does not satisfy the formula above, the device uses the nearest possible bit rate. To determine the actual bit rate, you may evaluate the return value of the function.**

For UART connections: only the following bitrates are allowed:

- 1.200 bit/s
- 2.400 bit/s
- 4.800 bit/s
- 9.600 bit/s
- 19.200 bit/s
- 38.400 bit/s
- 57.600 bit/s
- 115.200 bit/s
- 230.400 bit/s
- 460.800 bit/s

 **Setting other bit rates as those listed above will produce a runtime error.**

*framesize (integer), optional**

Only for SPI communication: Size of the data frame, can be 4 to 16 bits long, see

Figure 5.

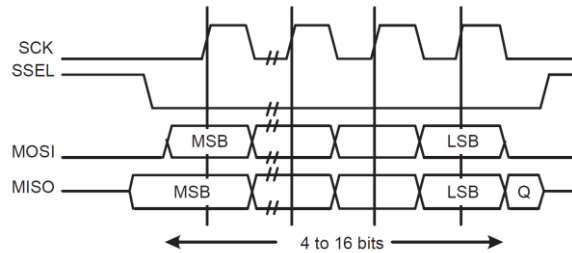

Figure 5: SPI Frame length

*cpol (boolean), optional**

Only for SPI communication: Clock polarity, see Figure 6 for explanation.

*cpha (boolean), optional**

Only for SPI communication: Clock phase, see Figure 6 for explanation.

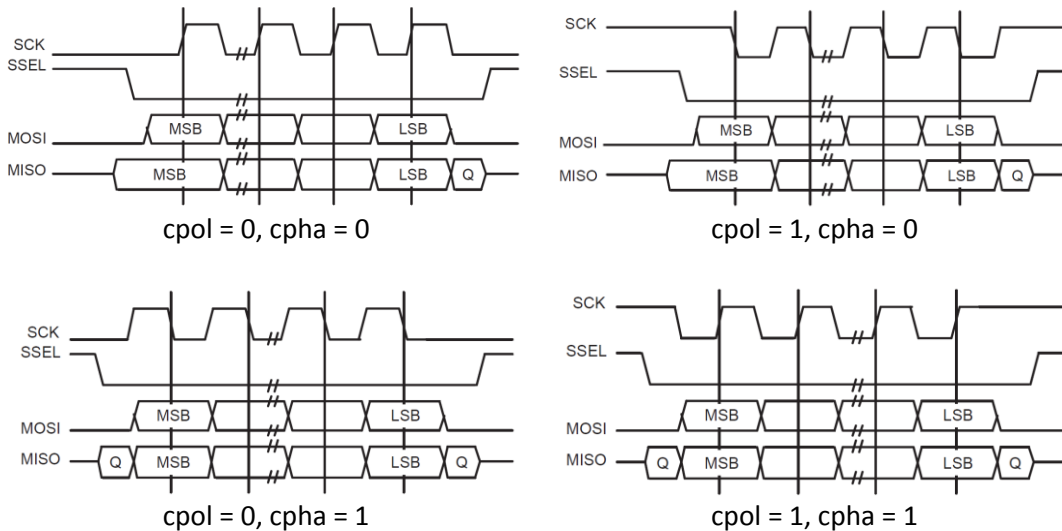

Figure 6: SPI Frame with available clock and phase settings

*) To configure the sensor interface properly, the following parameters are required, depending on the selected interface type:

Interface Type:	SPI	UART	none
index	required	required	required
ifacetype	required	required	required
bitrate	required	required	-
framesize	required	-	-



cpol	required	-	-
cpha	required	-	-

Return Value

The function returns two parameters:

- Interface used for communication. Can be of either
 - “none” - No interface is used.
 - “uart” - The UART interface is used.
 - “spi” - The SPI interface is used.
- Effective bitrate in bits per second (for interface “none”, 0 is returned).

Example

```
for i=0,finger.count()-1 do
  iface, speed = finger.interface( i );
  printf( "Finger %d interface: %s, speed: %d bps\n", i, iface, speed );
end;
```

```
-- Setting the interface of Finger 0 to UART mode with 115200 baud:
if ( finger.type( 0 ) == "generic" ) then
  finger.interface( 0, "uart", 115200 );
end;
```

```
-- Setting the interface of Finger 1 to SPI mode with 8 MBit/s, 8 bits per frame and CPOL=CPHA=0:
if ( finger.type( 1 ) == "generic" ) then
  finger.interface( 1, "spi", 8000000, 8, 0, 0 );
end;
```

2.8.6 Get finger state – `finger.state()`

Get the state of the finger with the given index. For a description of the Finger State Flags, see Appendix C (chapter 5).



If you want to read the finger state flags as a table, use `finger.flags()` instead (see Chapter 2.8.7)

Syntax

```
<integer> = finger.state( index [, mask] )
```

Parameters

index (integer)

Finger index. Range is 0..`finger.count()-1`.



mask (integer), optional

If passed, only the finger state flags that are masked (i.e. set to HIGH) will be returned.

Return Value

Returns the currently set finger state flags.

Example

```
for i=0,finger.count()-1 do
  if finger.state( i, 0x0001 ) then  -- Test for the FINGER ENABLED flag
    printf( "Finger %d is enabled! (state: %.4xh)\n", i, finger.state( i ) );
  else
    printf( "Finger %d is disabled!\n", i );
  end;
end;
end;
```

2.8.7 Get the finger state as table - finger.flags()

Get the currently set Finger State Flags as an associative table. The flags can be easily accessed by using their symbolic name, see the example below. Chapter 5 lists the symbolic names of the system flags.



If you want to read the system state flags as an integer value, use `finger.state()` instead (see Chapter Get finger state – `finger.state()` 2.8.6)

Syntax

<table> = `finger.flags(index)`

Availability

This command is available from firmware version 2.4.0 onwards

Parameters

index (integer)

Finger index. Range is 0..`finger.count()-1`.

Return Value

Current finger state flags as an associative table.

Example

```
flags = finger.flags(0);  -- returns the state flags of finger 0.
if flags.FF_POWER_ON == true then
  print(" Finger 0 is switched on!" );
```



```
else
    print(" Finger 0 is switched off!" );
end;
```

2.8.8 Control finger power – `finger.power()`

Enable or disable the power supply of the given finger. You can only control the power of generic fingers (see chapter 2.8.2), power control for predefined finger types is not possible.

This command will raise a runtime error, if

- you try to change the power of a finger whose type is different from “generic”
- you try to enable power of a short-circuited finger



You may check the current power state of the finger by evaluating its state flags via `finger.state()`, see chapter 2.8.2.

Syntax

```
finger.power( index, enabled )
```

Parameters

index (integer)

Finger index. Range is `0..finger.count()-1`.

enabled (integer)

Set to true to enable power for the resp. finger or to false to disable power.

Return Value

none

Example

```
if finger.type(0) == "generic" then
    printf( "Toggle power of finger 0...\n" );
    for i=1,5 do
        printf( "Step %d of 5\n", i );
        finger.power( 0, true ); -- enable power of finger 0
        sleep( 2000 );
        finger.power( 0, false ); -- disable power of finger 0
        sleep( 2000 );
    end;
    printf( "done!\n" );
else
    printf( "Not a generic finger, cannot change its power state.\n" );
end;
```



```
end;
```

2.8.9 Get analog voltage – `finger.analog()`

Get the analog voltage from the finger interface with the given index. The voltage signal is between 0 and 2.5 V. This command is only available for generic fingers.

Syntax

```
<number> = finger.analog( index )
```

Parameters

index (integer)

Finger index. Range is 0..`finger.count()`-1.

Return Value

Returns the voltage at the analog input pin of the selected finger interface in Volts.

Example

```
while true do
  printf( "Analog input: %.2fV\n", finger.analog( 0 ) ); -- Get the analog input voltage of finger 0
  sleep( 500 );
end;
```

2.8.10 Write data to finger – `finger.write()`

Write the given data to the indexed finger. Direct communication with the finger is only possible for generic fingers.

The data to be written is passed as a variable argument list that can contain integer types, Boolean types and string types as well as tables containing these types.

The following conversion rules will be applied:

- Integer and Number types are treated as single bytes, i.e. have a valid range of 0 to 255. If this range is exceeded, the function raises a runtime error. To send a number value, use the `ntob()` conversion function (see chapter 2.1.5).
- Boolean values are converted into a single byte set to 0 and 1, respectively.
- String values are converted into a sequence of bytes (without a trailing zero).
- Tables can contain the above types and can be nested at a total of up to 5 levels.

This command will raise a runtime error, if



- you try to write to a finger with predefined finger type
- you try to write to an unpowered finger
- the finger is not properly configured or configuration cannot be read

i If SPI is used for communication with the finger, `finger.write()` uses 16-bit frames for data exchange, even if the frame size is configured to 8 or less bits. This means that two consecutive bytes are used for each frame, e.g. to write 4 frames (0x0001, 0x0002, 0x0003, 0xF004) from finger 0 via SPI, use `finger.write(0,{1,0,2,0,3,0,4,0xF0})`.

i If SPI is used for communication, the received data that was clocked in while transmitting is discarded. Use the `finger.spi()` command, if you require to receive and transmit simultaneously.

Syntax

`finger.write(index, ...)`

Parameters

index (integer)

Finger index. Range is 0..`finger.count()`-1.

...

Variable arguments list containing the data to be sent. See description above.

Return Value

none

Example

```
if finger.type( 0 ) == "generic" then
  for i=1,10 do
    finger.write( 0, "Hello Finger, this is a test: "..tostring(i).."\n" );
  end;
else
  printf( "Cannot send data to a non-generic finger.\n" );
end;
```

2.8.11 Bytes available – `finger.bytes_available()`

Returns the number of bytes waiting in the input buffer of the given finger. For SPI communication, the function always returns 2, since SPI transfers aren't internally buffered.

The function returns 0 for non-generic fingers or if the finger is unpowered or not properly configured.

Syntax



<integer> = finger.bytes_available(index)

Parameters

index (integer)

Finger index. Range is 0..finger.count()-1.

Return Value

Number of bytes waiting in the input buffer.

Example

```
if finger.type( 0 ) == "generic" then
    printf( "%d bytes available\n", finger.bytes_available( 0 ) );
end;
```

2.8.12 Read data from finger – finger.read()

Read data from the finger with the given index. Direct communication is only possible for generic fingers. `finger.read()` returns the data in form of a table containing the received bytes. You can optionally specify the number of bytes to be read. The function blocks in case there is not enough data inside the receive buffer. If you don't specify the number of bytes to be read, the function returns all available data or an empty table, if there is currently no data available.

This command will raise a runtime error, if

- you try to read from a finger whose type is different from "generic"
- you try to read from an unpowered finger
- the finger is not properly configured or configuration cannot be read



If SPI is used for communication with the finger, `finger.read()` uses 16-bit frames for data exchange, even if the frame size is configured to 8 or less bits. This means that each frame is returned as two consecutive bytes, e.g. to read 4 frames from finger 0 via SPI, use `rxdata = finger.read(0, 8)`. The result will be a table containing 8 bytes that represent the 4 frames.



If SPI is used for communication, the gripper clocks out zeros to read the data. Use the `finger.spi()` command, if you require to receive and transmit simultaneously.

Syntax

<table> = finger.read(index, [count])

Parameters

index (integer)



Finger index. Range is 0..finger.count()-1.

count (integer), optional

Number of bytes to be read. If you try to read more bytes than currently available, the function will not return, until the given number of bytes is available.

Return Value

Table containing the received data.

Example

```
if finger.type( 0 ) == "generic" then
  while true do
    data = finger.read( 0 ); -- read data from finger 0
    if #data > 0 then
      for i=1,#data do -- print out all data, assuming it is ASCII coded.
        printf( "%c", data[i] );
      end;
    end;
  end;
else
  printf( "Cannot read data from a non-generic finger.\n" );
end;
```

2.8.13 Synchronous data transfer via SPI – finger.spi()

Exchange data with the finger with the given index. Direct communication is only possible with generic fingers.



This command can only be used, if the finger is configured to use the SPI interface and is intended as an alternative to `finger.read()` and `finger.write()` supporting true bidirectional data transfers.

The data to be written is passed as a variable argument list that can contain integer types, Boolean types and string types as well as tables containing these types. The length of the given table defines the number of frame transfers to be made.

The following conversion rules will be applied:

- Integer and Number types are treated as single frame, i.e. have a valid range of 0 to 65535 for a frame width of 16 bits. If this range is exceeded, the function raises a runtime error.
- Boolean values are converted into a single frame whose content is set to 0 or 1, respectively.
- String values are converted into a sequence of frames (without a trailing zero), one frame each character.



- Tables can contain the above types and can be nested at a total of up to 5 levels.

The simultaneously read data is returned as a table containing the single frames. Received data is assumed to be unsigned, so each value is in the range of 0 to 65535.

This command will raise a runtime error, if

- you try to communicate with a non-generic finger
- you try to communicate with an unpowered finger
- the finger is not properly configured or configuration cannot be read

Syntax

<table> = finger.spi(index, data)

Parameters

index (integer)

Finger index. Range is 0..finger.count()-1.

data (table)

Frame data to be sent. See conversion rules above.

Return Value

Table containing the received frame data. It will be of the same length as the given transmit data table.

Example

```
if finger.type( 1 ) == "generic" then
  while true do
    sleep( 1000 );
    rxdata = finger.spi( 1, 0x1234 ); -- SPI transfer with finger 0
    for i=1,#rxdata do -- print out the received data
      printf( "%.4Xh ", rxdata[i] );
    end;
    printf( "\n" );
  end;
else
  printf( "Cannot read data from a non-generic finger.\n" );
end;
```

2.8.14 Finger configuration memory – finger.config()

If the finger has a built-in configuration memory, this function allows you to read or write its content.



Accessing the finger configuration is only possible for generic fingers.



The finger configuration can be stored as value pairs in the form of “descriptor” = “value”.

`finger.config(index)` will always return an associative table containing the configuration value pairs. If you want to store an updated configuration set to the finger’s memory persistently, you may pass an optional table to the function containing the value pairs.

⚠ Neither values nor descriptors must contain Line Feeds (0Ah) or “=” characters, as these are used as internal storage formatters.

⚠ You should never set the descriptor key “type” manually to something different than `FT_GERERIC`, since this may render the Finger unusable !!!

Syntax

```
<table> = finger.config( index, data )
```

Availability

This command is available from firmware version 2.0.0 onwards

Parameters

index (integer)

Finger index. Range is `0..finger.count()-1`.

data (table)

New configuration data to be stored. You should pass an associative table using string descriptor keys (see the example below).

Return Value

Table containing the current finger configuration.

Example

```
if finger.type( 1 ) == "generic" then

    -- read the configuration of Finger 1:
    cfg = finger.config( 1 );

    -- Print the current finger configuration:
    for key in pairs( cfg ) do
        print( key, cfg[key] );
    end;

    -- Add a custom value pair to the configuration:
    cfg["key"] = 1.05;
```



```
-- Store the updated configuration to the finger's nonvolatile memory:
finger.config( 1, cfg );
else
  printf( "Cannot read the configuration data from a non-generic finger.\n" );
end;
```

2.9 Profibus

This module extends the scripting environment with Profibus functionality and virtual I/O terminals that can be used to interact with the connected PLC.

 **The Profibus Scripting Extension is only supported by devices that have a built-in Profibus interface**

Virtual I/O over Profibus

In addition to the gripping command interface, the WSG Grippers have 8 user input flags (IF1 to IF8) and eight user output flags (OF1 to OF8) that can be independently controlled. From the PLC side, they can be accessed as a normal input or output respectively, thus enabling an effective data exchange between a PLC program on the one side and the user script running on the WSG Gripper on the other.

 **for further details about the WSG's Profibus Interface, please see the "WSG Profibus Interface Manual"**

2.9.1 Get connection state – profibus.online()

Return the state of the Profibus connection.

Syntax

```
<online> = profibus.online()
```

Availability

This command is available from firmware version 2.2.0 onwards

Parameters

no parameters expected

Return Value

true, if the device is online.

Example

```
while profibus.online() do
```



```
-- Do something here...  
end;
```

2.9.2 Get bitrate – profibus.bitrate()

Return the currently used bit rate on the Profibus network.

Syntax

```
<bitrate> = profibus.bitrate()
```

Availability

This command is available from firmware version 2.2.0 onwards

Parameters

no parameters expected

Return Value

Bitrate in bits/s.

Example

```
if profibus.online() then  
    br = profibus.bitrate();  
    printf( "Bitrate: %d bit/s\n", br );  
else  
    printf( "Profibus is offline\n" );  
end;
```

2.9.3 Access an I/O flag – profibus.flag()

Read the state of the user input flag (IF) with the given index and optionally change the value of the corresponding user output flag (OF). This command can be used in conjunction with the PLC program to implement custom behavior on the device using scripts.

Syntax

```
<value> = profibus.flag( index, [setvalue] )
```

Availability

This command is available from firmware version 2.2.0 onwards

**Parameters***index (integer)*

User Flag index. Range is 1..8.

setvalue (bool), optional

New value for the indexed output user flag (OF).

Return Value

Current value of the input user flag (IF) as integer (i.e. '0' or '1').

Example

```
-- Movement speed is determined by the state of Input Flag 1
-- State of Output Flags 1 and 2 are toggled according to the position reached
POS_A = 10;
POS_B = 60;
position = POS_A;

profibus.fclear( 0xFF ); -- reset Output User Flags
while profibus.online() do

    -- Determine speed from the state of Input User Flag 1:
    if profibus.flag( 1 ) == 0 then
        speed = 50.0;
    else
        speed = 10.0;
    end;
    -- move and wait while busy:
    mc.move( position, speed, 1 );

    -- Toggle target position:
    if position == POS_A then
        profibus.flag( 1, 0 );
        profibus.flag( 2, 1 ); -- set Output User Flag 2 as ack to the PLC
        position = POS_B;
    else
        profibus.flag( 1, 1 ); -- set Output User Flag 1 as ack to the PLC
        profibus.flag( 2, 0 );
        position = POS_A;
    end;
end;
```



2.9.4 Write/read user flags – profibus.flags()

Read the state of all user input flags (IF) and optionally change the value of all user output flag (OF). This command can be used in conjunction with the PLC program to implement custom behavior on the device using scripts.

 if you want to read the state of a single flag or manipulate it, you can use the [profibus.flag\(\)](#) command instead.

Syntax

```
<value> = profibus.flags( [setvalue] )
```

Availability

This command is available from firmware version 2.2.0 onwards

Parameters

setvalue (integer), optional

New value for the output user flags (OF) as a bit field value, i.e. bit 0 of setvalue corresponds to OF1, bit 1 to OF2, ...

Return Value

Current value of the input user flags (IF) as a bit field value (i.e. bit 0 has state of IF1, bit 1 of IF2, ...).

Example

```
-- Simple counter example. The counting value is written to the Profibus Output Flags (OF)
count = 0;
while profibus.online() do
    count = count + 1;
    if count == 256 then
        count = 1;
    end;
    profibus.flags( count ); -- write counting value to the Profibus Output Flags
    sleep( 500 );
end;
```

2.9.5 Set one or more output flags – profibus.fset()

Set the state of one or more user output flags (OF) to '1'.

Syntax



profibus.fset(mask)

Availability

This command is available from firmware version 2.2.0 onwards

Parameters

mask (integer)

A bit field value for the output user flags (OF) where bit 0 corresponds to OF1, bit 1 to OF2, and so on. A '1' in the bit field will set the corresponding OF while a '0' has no effect.

Return Value

no return value.

Example

```
-- Set OF1, OF5 and OF7 (mask is 01010001b or 0x51)
if profibus.online() then
    profibus.fset( 0x51 );
end;
```

2.9.6 Clear one or more output Flags – profibus.fclear()

Set the state of one or more user output flags (OF) to '0'.

Syntax

profibus.fclear(mask)

Availability

This command is available from firmware version 2.2.0 onwards

Parameters

mask (integer)

A bit field value for the output user flags (OF) where bit 0 corresponds to OF1, bit 1 to OF2, and so on. A '1' in the bit field will clear the corresponding OF while a '0' has no effect.

Return Value

no return value.

Example



```
-- Clear OF1, OF5 and OF7 (mask is 01010001b or 0x51)
if profibus.online() then
    profibus.fclear( 0x51 );
end;
```

2.9.7 Wait for activity – profibus.waitact()

Wait for a state transition on one or more user input flags (IF). An optional timeout can be used. Use this function, if you have to wait on a change of certain input flags.

Syntax

<integer>, <integer> = profibus.waitact(mask, [timeout])

Availability

This command is available from firmware version 2.2.0 onwards

Parameters

mask (integer)

A bit field value for the input user flags (IF) that shall be monitored, where bit 0 corresponds to OF1, bit 1 to OF2, and so on. Write a '0' in the bit field at the flag position that has not to be monitored.

timeout (integer), optional

An optional timeout in milliseconds. If no activity on the selected user flags occurs after this time, the function returns with activity = 0.

Return Value

Two parameters are returned:

1. Parameter: "activity" (integer) is a bit field with '1's at the position of the changed input flags.
2. Parameter: "state" (integer) is the input flag state after the change. This can be used e.g. to detect the transition direction, i.e. raising or falling edge.

Example

```
-- Wait for Activity on IF1:
activity, state = profibus.waitact( 0x01 );
if activity ~= 0 then
    printf( "Activity detected!\n" );
    if state > 0 then
        printf( "Raising edge\n" );
    else printf( "Falling edge\n" );
end;
```



3 Appendix A: Error Codes

Error code	Symbol name	Description
0	E_SUCCESS	No error occurred, operation was successful
1	E_NOT_AVAILABLE	Function or data is not available
2	E_NO_SENSOR	No measurement converter is connected
3	E_NOT_INITIALIZED	Device was not initialized
4	E_ALREADY_RUNNING	The data acquisition is already running
5	E_FEATURE_NOT_SUPPORTED	The requested feature is currently not available
6	E_INCONSISTENT_DATA	One or more parameters are inconsistent
7	E_TIMEOUT	Timeout error
8	E_READ_ERROR	Error while reading data
9	E_WRITE_ERROR	Error while writing data
10	E_INSUFFICIENT_RESOURCES	No more memory available
11	E_CHECKSUM_ERROR	Checksum error
12	E_NO_PARAM_EXPECTED	A Parameter was given, but none expected
13	E_NOT_ENOUGH_PARAMS	Not enough parameters for executing the command
14	E_CMD_UNKNOWN	Unknown command
15	E_CMD_FORMAT_ERROR	Command format error
16	E_ACCESS_DENIED	Access denied
17	E_ALREADY_OPEN	Interface is already open
18	E_CMD_FAILED	Error while executing a command
19	E_CMD_ABORTED	Command execution was aborted by the user
20	E_INVALID_HANDLE	Invalid handle
21	E_NOT_FOUND	Device or file not found
22	E_NOT_OPEN	Device or file not open
23	E_IO_ERROR	Input/Output Error



24	E_INVALID_PARAMETER	Wrong parameter
25	E_INDEX_OUT_OF_BOUNDS	Index out of bounds
26	E_CMD_PENDING	No error, but the command was not completed, yet. Another return message will follow including an error code, if the function was completed.
27	E_OVERRUN	Data overrun
28	RANGE_ERROR	Range error
29	E_AXIS_BLOCKED	Axis blocked
30	E_FILE_EXISTS	File already exists

4 Appendix B: System State Flags

The System State Flags are arranged as a 32-bit wide integer value that can be read using the function `system.state()` (see chapter 2.3.1). Each bit has a special meaning listed below.

Bit No.	Flag Name	Description
D31..21	reserved	These bits are currently unused but may be used in a future release of the WSG firmware.
D20	SF_SCRIPT_FAILURE	Script Error. An error occurred while executing a script and the script has been aborted. This flag is reset whenever a script is started.
D19	SF_SCRIPT_RUNNING	A script is currently running. The flag is reset if the script either terminated normally, a script error occurred or the script has been terminated manually by the user.
D18	SF_CMD_FAILURE	Command Error. The last command returned an error.
D17	SF_FINGER_FAULT	Finger Fault. The status of at least one finger is different from “operating” and “not connected”. Please check the finger flags for a more detailed error description.



D16	SF_CURR_FAULT	<p>Engine Current Error.</p> <p>The engine has reached its maximum thermal power consumption. The flag will be reset automatically as soon as the engine has recovered. Then the corresponding Fast Stop can be committed.</p>
D15	SF_POWER_FAULT	<p>Power Error.</p> <p>The power supply is outside the valid range.</p>
D14	SF_TEMP_FAULT	<p>Temperature Error.</p> <p>The gripper hardware has reached a critical temperature level. All motion related commands are disabled until the temperature falls below the critical level.</p>
D13	SF_TEMP_WARNING	<p>Temperature Warning.</p> <p>The gripper hardware will soon reach a critical temperature level.</p>
D12	SF_FAST_STOP	<p>Fast Stop.</p> <p>The gripper has been stopped due to an error condition. You have to acknowledge the error in order to reset this flag and to re-enable motion related commands.</p>
D11..10	reserved	<p>These bits are currently unused but may be used in a future release of the WSG firmware.</p>
D9	SF_FORCECNTL_MODE	<p>Force Control Mode.</p> <p>True Force Control is currently enabled by using the installed Force Measurement Finger (WSG-FMF). If this flag is not set, the grasping force is controlled by approximation based on the motor current.</p>
D8	reserved	<p>This bit is currently unused but may be used in a future release of the WSG firmware.</p>
D7	SF_TARGET_POS_REACHED	<p>Target position reached.</p> <p>Set if the target position was reached. This flag is not synchronized with SF_MOVING, so it is possible that there is a delay between SF_MOVING being reset and SF_TARGET_POS becoming active.</p>
D6	SF_AXIS_STOPPED	<p>Axis stopped.</p> <p>A previous motion command was aborted using the stop command. This flag is reset on the next motion command.</p>



D5	SF_SOFT_LIMIT_PLUS	<p>Positive direction soft limit reached.</p> <p>The fingers reached the defined soft limit in positive moving direction. A further movement into this direction is not allowed anymore. This flag is cleared, if the fingers have been moved away from the soft limit position.</p>
D4	SF_SOFT_LIMIT_MINUS	<p>Negative direction soft limit reached.</p> <p>The fingers reached the defined soft limit in negative moving direction. A further movement into this direction is not allowed anymore. This flag is cleared, if the fingers have been moved away from the soft limit position.</p>
D3	SF_BLOCKED_PLUS	<p>Axis is blocked in positive moving direction.</p> <p>Set if the axis is blocked in positive moving direction. The flag is reset if either the blocking condition has been resolved or a stop command has been issued.</p>
D2	SF_BLOCKED_MINUS	<p>Axis is blocked in negative moving direction.</p> <p>Set if the axis is blocked in negative moving direction. The flag is reset if either the blocking condition has been resolved or a stop command has been issued.</p>
D1	SF_MOVING	<p>The Fingers are currently moving.</p> <p>This flag is set whenever a movement is started (e.g. MOVE command) and reset automatically if the movement stops.</p>
D0	SF_REFERENCED	<p>Fingers Referenced.</p> <p>If set, the gripper is referenced and accepts movement commands.</p>

5 Appendix C: Finger State Flags

The finger state flags are arranged as a 16-bit wide integer value that can be read using the function `finger.state()` (see chapter 2.8.1). Each bit has a special meaning listed below.

Bit No.	Flag Name	Description
D15..10	reserved	These bits are currently unused but may be used in a future release of the WSG firmware.



D9	FF_COMM_FAULT	Communication Fault. A communication error occurred during runtime.
D8	FF_POWER_FAULT	Power Fault. An over-current condition was detected at the resp. finger.
D7..2	reserved	These bits are currently unused but may be used in a future release of the WSG firmware.
D1	FF_CONFIG_AVAIL	Configuration available. If the connected finger provides a configuration memory and its content is valid, this bit is set.
D0	FF_POWER_ON	Power enabled. If true, the finger is powered up.

6 Appendix D: Syntax Notation

The following command syntax notation is used throughout this document:

Parameters

- a Denotes a mandatory parameter
- [a] Denotes an optional parameter
- {a, b, c} Denotes a selection of mandatory parameters (exactly one must be present)
- [[a, b, c]] Selection of optional parameters (either exactly one or none must be present)

Values

- <integer> An integer value
- <number> A floating point value
- <string> A string literal
- <table> A table
- <var> variable type



Weiss Robotics GmbH & Co. KG

In der Gerste 2

D-71636 Ludwigsburg, Germany

e-mail: office@weiss-robotics.com

For further information and other products from Weiss Robotics, please visit our homepage at <http://www.weiss-robotics.com>.

© 2010-2012 Weiss Robotics, all rights reserved.

All technical data mentioned in this data sheet can be changed to improve our products without prior notice. Used trademarks are the property of their respective trademark owners. Our products are not intended for use in life support systems or systems whose failure can lead to personal injury.