



Rack installation instructions

Review the documentation that comes with the rack cabinet for safety and cabling information. Before you install the server in a rack cabinet, review the following guidelines:

- Two or more people are required to install devices 2U or larger in a rack cabinet.
- Make sure that the room air temperature is below 35°C (95°F).
- Do not block any air vents; usually 15 cm (6 in.) of space provides proper airflow.
- Do not leave open spaces above or below an installed server in your rack cabinet. To help prevent damage to server components, always install a blank filler panel to cover the open space and to help ensure proper air circulation.
- Install the server only in a rack cabinet with perforated doors.
- Plan the device installation starting from the bottom of the rack cabinet.
- Install the heaviest device in the bottom of the rack cabinet.
- Always install the tip plates on the rack.
- Do not extend more than one device out of the rack cabinet at the same time.
- Remove the rack doors and side panels to provide easier access during installation.
- Connect the server to a properly grounded outlet.
- Do not overload the power outlet when you install multiple devices in the rack cabinet.
- Install the server in a rack that meets the following requirements:
 - Minimum depth of 70 mm (2.76 in.) between the front mounting flange and inside of the front door.
 - Minimum depth of 157 mm (6.18 in.) between the rear mounting flange and inside of the rear door.
 - Minimum depth of 718 mm (28.27 in.) and maximum depth of 762 mm (30 in.) between the front and rear mounting flanges to support the use of the cable-management arm.



Use safe practices when lifting.



≥18 kg (39.7 lb)



≥32 kg (70.5 lb)



≥55 kg (121.2 lb)



Do not place any objects on top of rack-mounted devices.



Notes:

1. If you are scaling this server as part of a multinode system, see the rack installation instructions that come with the option kit for instructions on installing the extra hardware required in the multinode setup.
2. You can install the cable-management arm on either side of the server. The installation instructions in this document can be reversed if you are installing the cable-management arm on the side of the server that is not shown.
3. Cage nuts and clip nuts are not required to install the server in a rack cabinet.

The following illustration shows the items that you need to install the server in the rack cabinet. If any items are missing or damaged, contact your place of purchase.

Note: Some items come with the server, not in the rack installation kit.

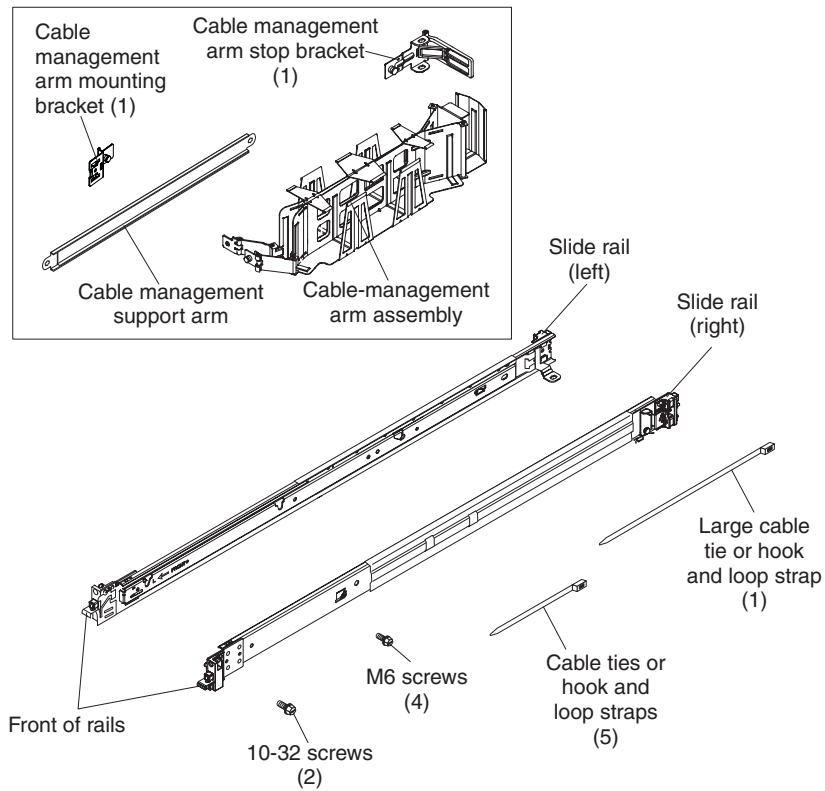

Use the following illustration of the front and rear rack-mounting flanges to determine the appropriate rack-mounting holes for installing the slide rails.

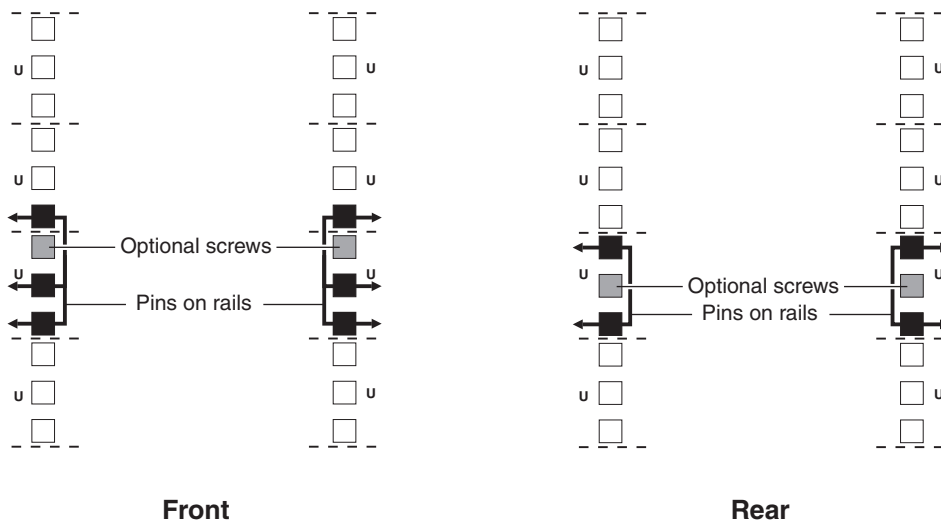

Note: If the slide rails in your rack installation kit came with shipping thumbscrews, remove them before you begin the following installation procedure.

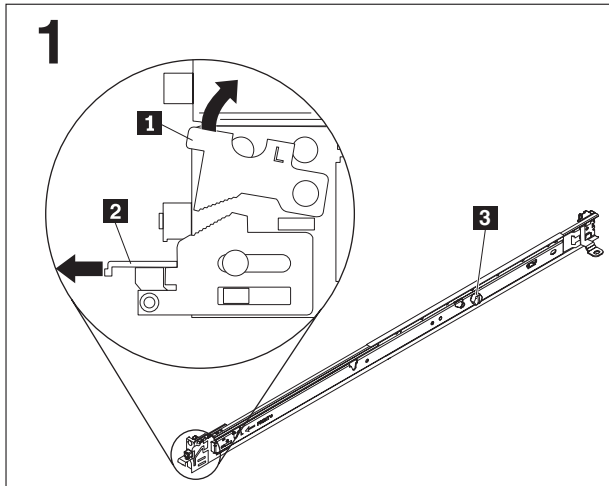

Open the front slide rail latches.

Each slide rail is marked with either an R (right) or an L (left). Select one of the slide rails and push up on the front moveable tab **1**; then, pull out the front latch **2**. If a thumbscrew is installed in the slide rail **3**, remove it.

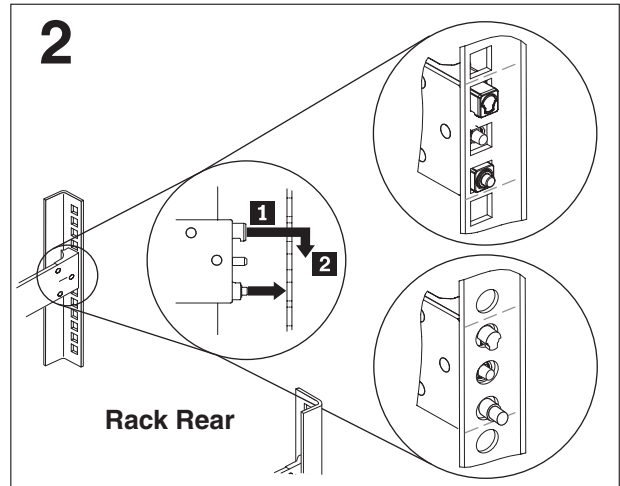

Install the rear end of the slide rails.

Note: When you install a 4U server, be sure to install the slide rails in the second U from the bottom of the 4U area in the rack.

From the front of the rack, line up the three pins on the rear of the slide rail with the three holes in the selected U on the rear of the rack. Push the rails so that the pins go into the holes **1**, and drop the slide rail down **2** until it latches into place.

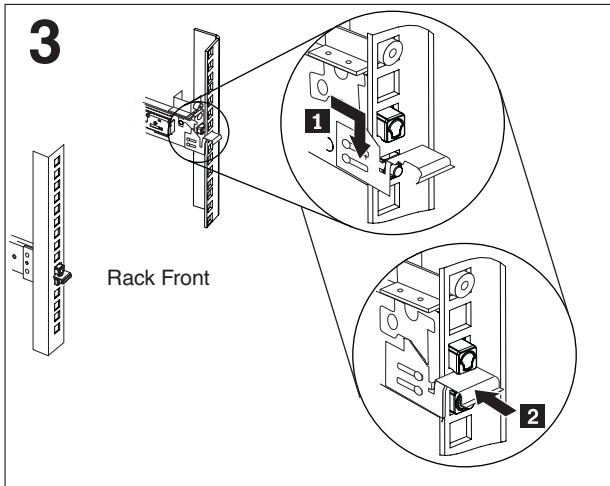

Install the front end of the slide rails.

Pull the slide rail forward and insert the two lower pins **1** on the front of the rail into the two lower holes in the U on the front of the rack. Drop the rail into place until it clicks. Push the front latch **2** in all the way with one hand while you pull on the rail assembly with your other hand. Make sure that the front of the rail flange is in contact with the EIA flange.

Repeat steps 1 through 3 to install the other rail into the rack. Make sure that each front latch is fully engaged.

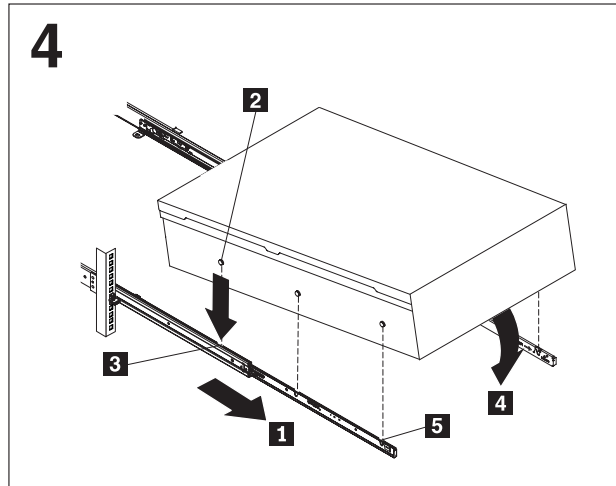

Install the server on the slide rails.

Pull the slide rails forward **1** until they click, two times, into place. Carefully lift the server and tilt it into position over the slide rails so that the rear nail heads **2** on the server line up with the rear slots **3** on the slide rails. Slide the server down until the rear nail heads slip into the two rear slots, and then slowly lower the front of the server **4** until the other nail heads slip into the other slots on the slide rails. Make sure that the front latch **5** slides over the nail heads.

It is possible to install the server horizontally, but it is easier to install when the server is tilted.

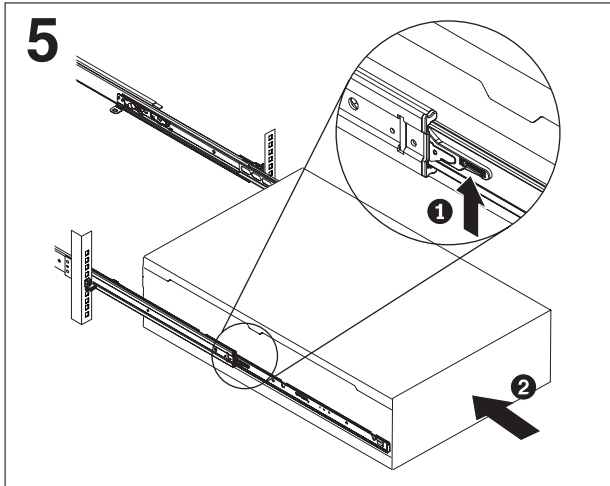

Slide the server into the rack.

Lift the locking levers **1** on the slide rails and push the server **2** all the way into the rack until it clicks into place.

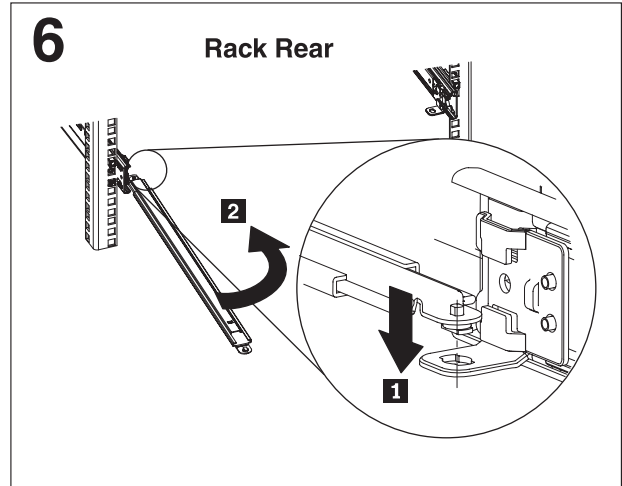

Install the cable management support arm.

The cable-management arm can be installed on either side of the server. This document shows it being installed on the left side. To install the cable-management arm on the right side, follow the instructions and install the hardware on the opposite side.

Connect one end of the support arm **1** to the same slide rail to which you plan to attach the cable-management arm so that you can swing the other end of the support arm **2** toward the rack. Make sure the shiny bar is on top, as shown in the illustration.

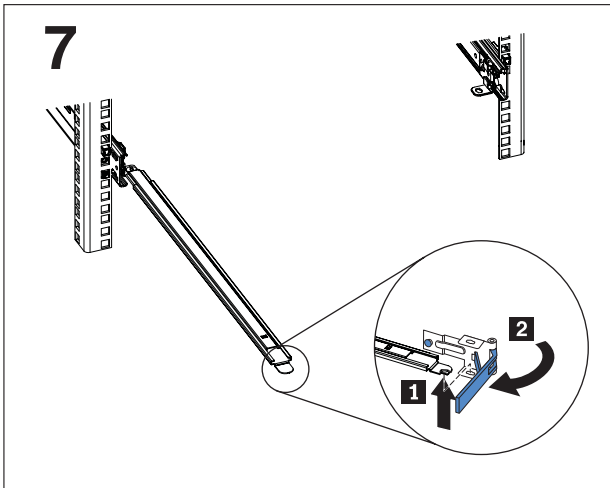

Install the cable management arm stop bracket.

Install the L-shaped cable-management stop bracket **1** on the unattached end of the support arm. Turn the bracket **2** to secure it to the support arm.

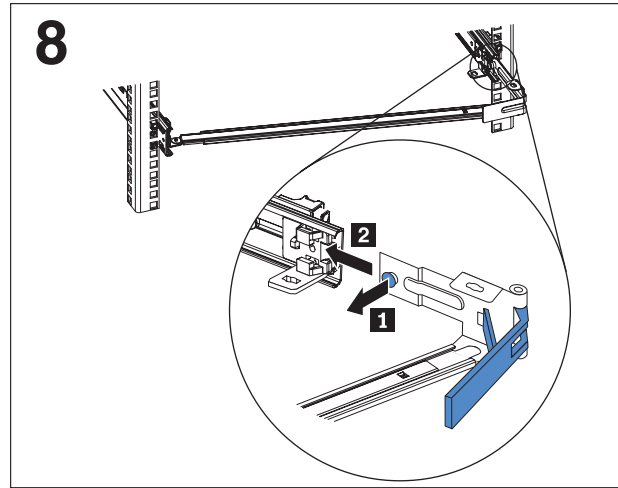

Connect the stop bracket to the slide rail.

To attach the other side of the support arm to the rear of the slide rail, pull the pin out **1**, and then slide the bracket **2** into the slide rail.

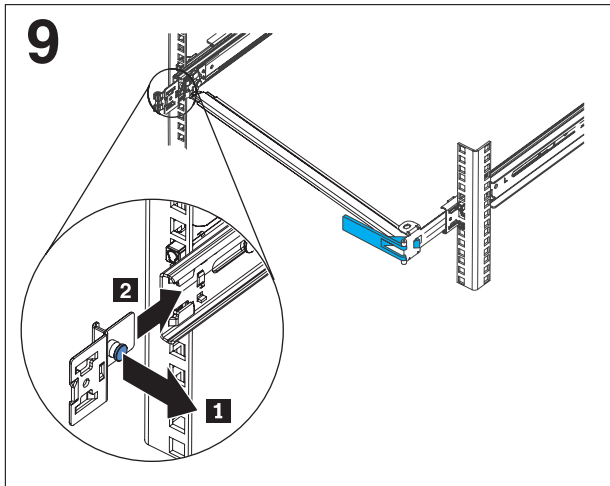

Install the cable management arm mounting bracket.

Pull out the mounting bracket pin **1** and slide the mounting bracket **2** into the slide rail onto which you are installing the cable-management arm. Push the bracket into the slide rail until the spring-loaded pin snaps into place.

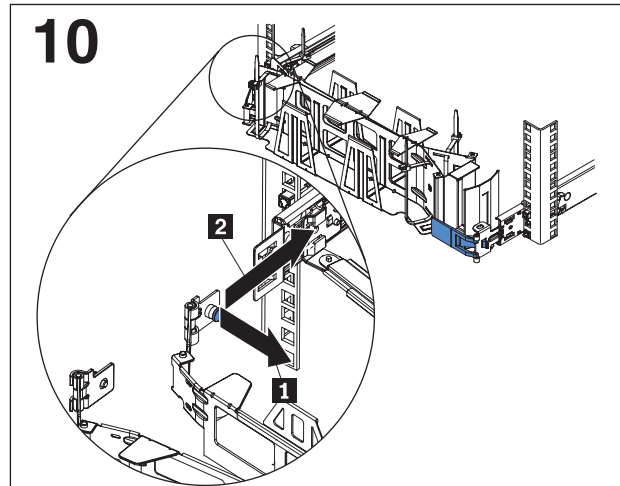

Install the cable management arm.

Place the cable-management arm on the support arm. Pull out the cable-management arm pin **1**, and then slide the cable-management arm tab **2** into the slot on the inside of the slide rail. Push the tab until it snaps into place.

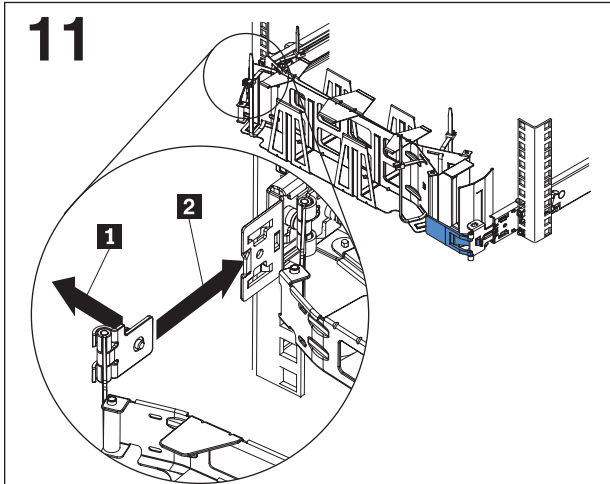

Install the cable management arm.

Pull out the other cable-management arm pin **1**, and then slide that cable management arm tab into the slot **2** on the outside of the slide rail. Push the tab until it snaps into place.

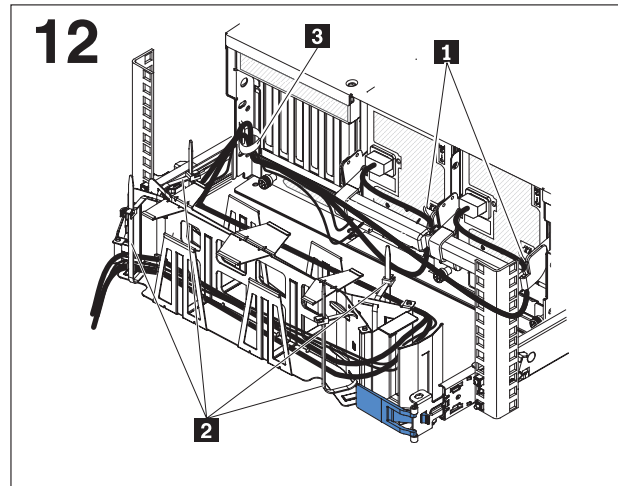

Connect and route the cables.

Attach the power cords and other cables to the rear of the server (including keyboard, monitor, and mouse cables, if required). (To access the rear of the server, lift the cable management arm above the stop bracket and rotate it out of the way.)

Route the cables and power cords through the cable clamps **1** on the back of the power supplies, then route them in the cable-management arm **2** and secure them with cable ties or hook-and-loop fasteners. Thread a cable tie through the loop **3** on the rear of the server and secure the cables in place so that they do not drop below the cable management arm.

Note: Allow slack in all cables to avoid tension in the cables as the cable-management arm moves.

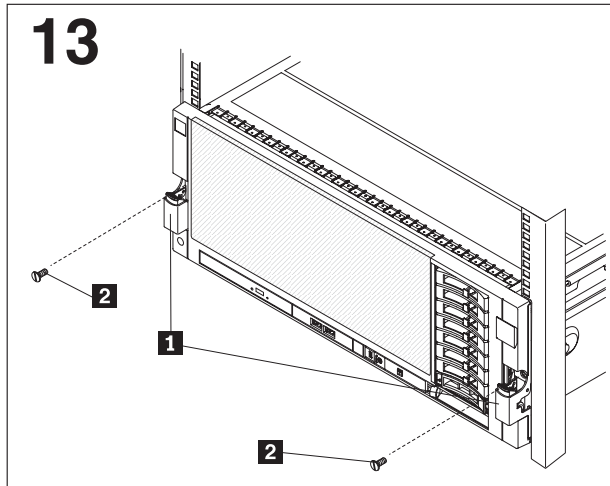

Install the front screws, if necessary.

Slide the server into the rack until it snaps into place. To slide the server out of the rack, press on the release latches **1**.

Note: When you move the rack cabinet, or if you install the rack cabinet in a vibration-prone area, insert the optional M6 screws **2** in the front of the server.

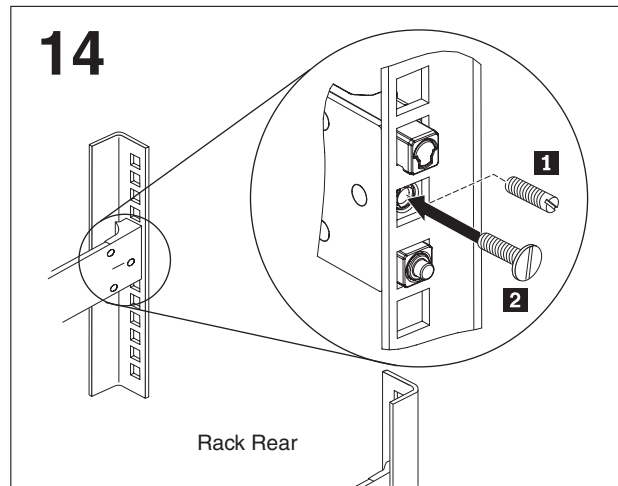

Secure the cable management arm and the server in the rack for shipping.

To ship the server in a rack, use a flat blade screwdriver to remove the screws **1** from the rear of the slides and replace them with the 10-32 **2** screws. Use a cable tie to secure the free end of the cable management arm to the EIA rack.

Removing the server from the rack

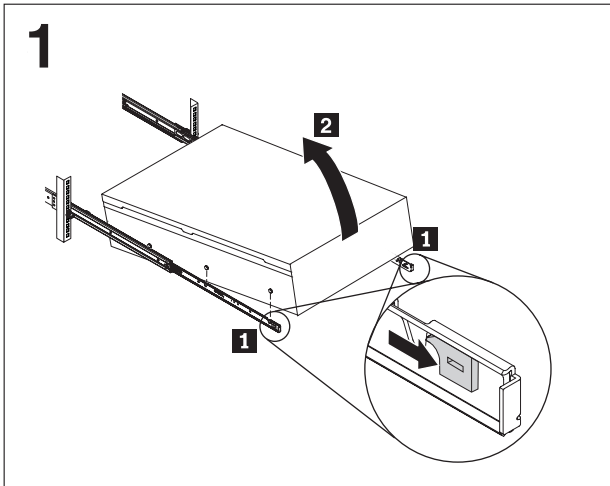

Unlatch and rotate the front of the server.

To remove the server from the rack, disconnect the cables from the rear of the server. Remove the cable management arm by pulling the pins out while sliding the tabs out of the mounting location.

Pull the locking levers **1** forward, while supporting the rear of the server, and lift the front of the server up slightly **2** to clear the nailhead from the slot.

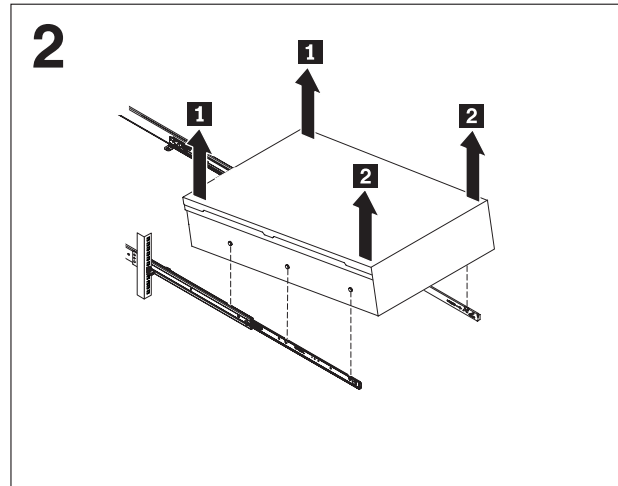

Lift the server off of the slide rails.

After the front nailheads clear the latches, lift up on the rear **1** of the server to level the server. Lift the server out of the rack **2** and place it on a sturdy surface.

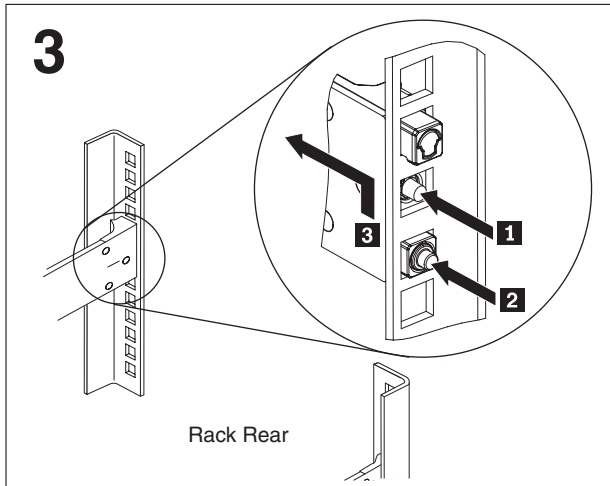

Remove the rear end of the slide rails.

To disengage the slide rails from the rear of the rack, push in the pins (**1** and **2**) and then push back on the rail **3** .

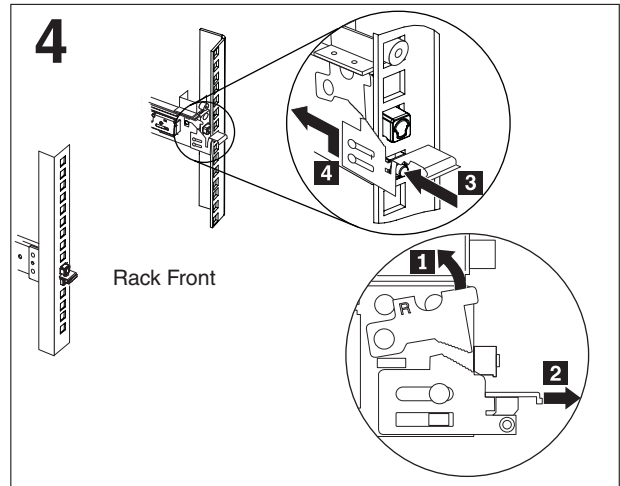

Remove the front end of the slide rails.

To remove the slide rails from the front of the rack, push up the front tab **1** and slide out the front latch **2** . Push in the lower pin **3** and lift up slightly on the front of the slide rail **4** . Remove the slide rail from the rack.

Store this information with your server documentation for future use.

First Edition (February 2010)

Printed in the U.S.A.

IBM is a trademark of the IBM Corporation in the United States, other countries, or both.

© **Copyright IBM Corporation 2010.**

US Government Users Restricted Rights – Use, duplication or disclosure restricted by GSA ADP Schedule Contract with IBM Corp.

(1P) P/N: 59Y7193

