

**DENSO ROBOT**  
**RC8 CONTROLLER**

**ELECTRIC GRIPPER**  
**USER'S MANUAL**

Copyright © DENSO WAVE INCORPORATED, 2012

All rights reserved. No part of this publication may be reproduced in any form or by any means without permission in writing from the publisher.

Specifications are subject to change without prior notice.

All products and company names mentioned are trademarks or registered trademarks of their respective holders.

1.	Preface.....	1
2.	FOR SAFE USE.....	2
2.1.	CAUTION.....	3
2.1.1.	General.....	3
2.1.2.	Design.....	3
2.1.3.	Operating Environment.....	4
2.1.4.	Installation.....	4
2.1.5.	Operation.....	4
2.1.6.	Maintenance and Inspection.....	4
2.2.	WARNING.....	5
2.2.1.	Operating Environment.....	5
2.2.2.	Installation.....	5
2.2.3.	Operation.....	6
2.2.4.	Maintenance and Inspection.....	6
2.2.5.	Disposal.....	7
2.3.	CAUTION.....	7
2.3.1.	General.....	7
2.3.2.	Working Environment.....	7
2.3.3.	Fixing the Product.....	8
2.3.4.	Operation.....	8
2.3.5.	Maintenance and Inspection.....	8
2.3.6.	Storage Environment.....	8
2.3.7.	Disposal.....	9
3.	Handling Instructions and Precautions.....	10
3.1.	Names of the Parts.....	10
3.2.	Design.....	11
3.2.1.	Design of Fingers.....	11
3.3.	Selection.....	12
3.3.1.	Gripping Force vs Instruction Value.....	12
3.4.	Installation.....	14
3.4.1.	Installation Bolts.....	14
3.4.2.	Mounting surface.....	15
3.4.3.	Connecting the Electric Gripper Connection Cable.....	22
3.4.4.	System Configuration.....	23
3.5.	Trial Run and Adjustment.....	24
3.5.1.	Setting Operation Mode.....	24

3.5.2.	Operating with electric gripper command.....	24
3.5.3.	Removing a Workpiece .....	24
3.6.	Maintenance and Inspection .....	25
3.6.1.	Inspection Timings and Items.....	25
3.6.2.	Procedure for Visual Inspection.....	25
3.6.3.	Conducting Operation Check .....	25
3.6.4.	Reapplication of Grease .....	26
3.6.5.	Cleaning Outside of the Gripper.....	28
4.	Specifications.....	29
5.	External Dimensions .....	31



## **1. Preface**

Thank you for purchasing our DRH-ESG1 Series Electric Gripper.

This operation manual contains information necessary to use the DRH-ESG1 Series. Be sure to read the respective operation/instruction manuals for the electric gripper, electric gripper control board, and electric gripper command to gain a firm understanding of their content before use. Be sure to store the manual in a readily accessible location after reading in order that it may be referenced at any time.

## 2. FOR SAFE USE

Cautionary descriptions given here are for correct use of the products and for prevention of hazard on you and other people in vicinity and damage with equipment. These descriptions are divided into three items of “DANGER”, “WARNING” and “CAUTION” depending on the severity of hazard or damage and level of imminence. All bear important descriptions pertaining to safety. Strictly observe the instructions in addition to those of ISO 10218-2\*<sup>1)</sup> and other safety rules.

	<b>DANGER</b>	Indicates an imminently hazardous situation which, if not avoided, will result in death or serious injury.
	<b>WARNING</b>	Indicates a potentially hazardous situation which could result in death or serious injury, if the equipment is operated wrongly.
	<b>CAUTION</b>	Indicates a potentially hazardous situation which may result in injury and machine damage, if the equipment is operated wrongly.

1) ISO 10218-2: Robots and robotic devices -- Safety requirements for industrial robots -- Part 2: Robot systems and integration

- This product is designed and manufactured as a component for use in general industrial machinery.
- Devices must be selected and handled by system designer, personnel in charge of the actual operation using the product or similar individual with sufficient knowledge and experience.
- Be sure to read the catalogue and operation manual before handling the product. Mishandling of the product poses a risk. Please read the respective operation/instruction manuals for the electric gripper, electric gripper control board, and electric gripper command.
- It is the user’s responsibility to verify and determine the compatibility of this product with the user’s system, and to use them properly.
- After reading the catalog, operation manual and other materials, be sure to keep them in a convenient place easily accessible to the personnel using this product.
- The danger, warning and caution directions in this “Safety Precautions” do not cover every possible case. Please read the catalog and operation manual for the given device, particularly for descriptions unique to it, to ensure its safe and proper handling.
- If the electric gripper is used integrated into a system (machine, robot, etc.), the system must satisfy regulations and standards for safety measures. First check whether the system satisfies the relevant regulations and standards, and if so, handle

the product properly in accordance with the regulations and standards. The electric gripper is an end effector for the robot system. When you design and/or assemble an electric gripper, be sure to satisfy all requirements and conditions written in ISO 10218-2.

- When you design and/or assemble an electric gripper, you must comply with the stipulation of ISO10218-2 "End-effectors shall be designed and constructed so that the loss or change of energy supply (e.g. electrical, hydraulic, pneumatic, vacuum supply) does not cause release of the load that would result in a hazardous condition. When practicable, power can be supplied to end-effectors for troubleshooting without applying motive energy to the robot actuator(s)."
- Do not use the product for the following applications:
  1. Medical equipment used to maintain, control or otherwise affect human life or physical health
  2. Mechanisms and machinery designed for the purpose of moving or transporting people
  3. Important safety parts of machinery

This product has not been planned or designed for applications requiring high levels of safety. Use of this product in such applications may jeopardize the safety of human life.

## 2.1. CAUTION

### **2.1.1. General**

Do not use the product outside the specifications. Using the product outside the specifications may cause it to fail, stop functioning or sustain damage. It may also significantly reduce the service life of the product.

### **2.1.2. Design**

- If the machine will stop in the case of system (machine, robot, etc.) problem such as emergency stop or power failure, design a safety circuit or other device that will prevent equipment damage or injury.
- To avoid falling a work piece that the electric gripper holds when the loss of power supply to the robot, design a circuit so that the power supply for the electric gripper is maintained or design fingers so that it does not drop a work piece.
- If you require an electric gripper that equips a function to keep holding a work piece (grip force), please contact our sales representatives.

### **2.1.3. Operating Environment**

- Do not use this product in a place exposed to ignitable, inflammable or explosive substances. The product has not been designed with explosion protection. The product may explode or ignite, resulting in product damage or injury.
- Do not use the product in a place where it may be exposed to water or oil droplets.

### **2.1.4. Installation**

Wire the product correctly by referring to the ELECTRIC GRIPPER CONTROL BOARD USER'S MANUAL. Securely connect the cables and connectors so that they will not be disconnected or come loose. Failure to do so may cause the product to malfunction or cause fire.

### **2.1.5. Operation**

- When operating or adjusting the gripper after it was mounted to the system (machine, robot, etc.), be sure to observe safety measures for the system. Failure to do so may result in serious injury.
- Before supplying power to and operating the product, always check the operation area of the equipment to ensure safety. Supplying power to the product carelessly may cause electric shock or injury due to contact with the moving parts.
- Do not touch the connectors or other parts power being supplied to the product. It may result in electric shock or malfunction.
- If you are using a pace maker or other mechanical implant, do not come within one meter of the product. The strong magnetic field generated by the product may cause the pace maker, etc., to malfunction. Keep pacemaker wearers one meter away from the product. The pacemaker may not work properly due to strong magnetic affection.
- Do not pour water onto the product. Spraying water over the product, washing it with water or using it in water may cause the product to malfunction, resulting in injury, electric shock, fire, etc.
- When conducting operation checks or performing operation, increase the robot speed gradually to check whether the electric gripper gripping force can be sustained relative to the robot speed. If not, there is a possibility of danger such as flying workpieces.

### **2.1.6. Maintenance and Inspection**

- If the electric gripper is used integrated into a system (machine, robot, etc.), ensure



that regulations and standards for safety measures are strictly observed, and use the product properly and safely.

- Do not disassemble and reassemble the components relating to the basic structure of the product or its performance and function. Doing so may result in injury, electric shock, fire, etc.
- Never cut and/or reconnect the cables supplied with the product for the purpose of extending or shortening the cable length. Doing so may result in fire.

2.2.



**WARNING**

### **2.2.1. Operating Environment**

- Do not use the product under direct sunlight or ultraviolet ray.
- Do not expose the product to radiant heat generated from a heat source.
- Use the product within the ambient temperature range of 0°C to 40°C.
- Use the product in the place having humidity range of 35% to 85% (without dew condensation).
- Do not use the product in an atmosphere of corrosive gases (sulfuric acid or hydrochloric acid). Rust may form and reduce the structural strength of the product.
- Do not use the product in a place exposed to dust, iron powder. If dust enters the product through small openings and gaps, the product may suffer damage.
- Do not use the product in a place where it may come in contact with water droplets, cutting oil, cleansing liquid, organic solvent, and operating oil. If expected, sufficiently protect the product with a cover or panel. Since the product has not been designed with waterproof, water droplets or other liquid may enter the product, resulting in product damage.
- Do not install the product in a place subject to large vibration or impact (9.8 m/s<sup>2</sup>). Doing so may result in the malfunctioning of the product.
- Do not use the product in the place where high magnetic field may cause electromagnetic interference. Failure to do so may result in malfunction.
- Do not use the product in the places where large current or high magnetic field is present, welding or other operations are performed that cause arc discharge, subject to electrostatic noise, and with potential exposure to radiation. Failure to do so may result in malfunction.

### **2.2.2. Installation**

- Provide an emergency-stop device in a readily accessible position so the device can

be actuated immediately upon occurrence of a dangerous situation during operation. Lack of such device in an appropriate position may result in injury.

- When installing the product including fingers, be sure to securely support and mount them. Failure to do so may cause the product or workpiece to tip over, drop or malfunction, resulting in injury.
- Provide sufficient maintenance space when installing the product. Routine inspection and maintenance cannot be performed without sufficient space, which will eventually cause the equipment to stop or the product to sustain damage.
- Before installing or adjusting the product or performing other operations on the product, display a sign that reads, "WORK IN PROGRESS. DO NOT TURN ON POWER." If the power is turned on inadvertently, injury may result due to electric shock or sudden activation of the controller.
- Do not hold the moving parts of the product or its cables during installation. It may result in injury.

#### **2.2.3. Operation**

- Keep your fingers away from the product to prevent you from being caught into the other devices.
- Do not touch the connectors or exposed terminals of the electric gripper control board. Doing so may result in electric shock.
- Turn off the power of the electric gripper in the event of power failure. Failure to do so may cause the product to suddenly start moving when the power is restored, thus resulting in injury or product damage.
- When moving electric gripper finger by hand for the purpose of manual positioning, etc., confirm that the motor of the electric gripper is turned off beforehand. Failure to do so may result in injury.
- If the product is generating heat, smoke or a strange smell, turn off the power immediately. Continuing to use the product may result in product damage or fire.
- If any of the internal protective (alarms) function of the product has actuated, turn the electric gripper power off immediately. Continuing to use the product may result in product damage or injury due to malfunction. Once the power supply is cut off, investigate and remove the cause and then turn on the power again.

#### **2.2.4. Maintenance and Inspection**

- Before conducting maintenance/inspection, parts replacement, or other operations on the product, completely shut down the power supply. At this time, take the

following measures:

1. Display a sign that reads, "WORK IN PROGRESS. DO NOT TURN ON POWER" at a conspicuous place, in order to prevent a person other than the operator from accidentally turning on the power while the operation is working.
  2. When two or more operators are to perform maintenance/inspection together, always call out every time the power is turned on/off or a moving part is moved in order to ensure safety.
- Perform inspection or maintenance work with a thorough understanding of the specific tasks. Insufficient maintenance/inspection by the user may result in reduction of service life of the moving parts and malfunction. If any abnormalities are detected, stop the operation immediately.

#### **2.2.5. Disposal**

Do not throw the product into fire. The product may burst or generate toxic gases.

**2.3.**



**CAUTION**

#### **2.3.1. General**

- If you are planning to use the product under a condition or environment not specified in the catalogs or operation manual, or in an application requiring strict safety such as aircraft facility, combustion system, entertainment machine, clean room, safety device, or other equipment having significant impact on human life or property, design operating ranges with ample margins from the ratings and design specifications, or provide sufficient safety measures such as fail-safes. Whatever you do, always consult us.
- Always use the cable supplied with the product for connection between the electric gripper and electric gripper control board.
- Use DENSO WAVE genuine products for main components such as electric gripper, electric gripper control board.

#### **2.3.2. Working Environment**

- Provide sufficient space when performing maintenance and inspection safely.
- Do not bring a floppy disk or other magnetic media within one meter of the product. The magnetic field generated by the magnet may destroy the data in the floppy disk, etc.

### **2.3.3. Fixing the Product**

- When handling the product, wear protective gloves, protective goggles, safety shoes, or other necessary gear to ensure safety.
- Protect the product from excessive impact load such as bumping or throwing.
- Do not step onto the package or place on the package a heavy object that allows the load concentrate.
- After unpacking the product, do not carry by holding cables or connectors.
- The electric gripper connection cables supplied with the product are flexible, but do not store the cables in a movable cable duct (cable bearer, etc.) that bends more than the specified bending radius.
- Do not scratch the electric gripper connection cable. Scratching, forcible bending, straining, winding, and pinching may cause short circuit and insulation failure, which results in electric shock and malfunction.
- The workpiece gripping force will be lost if an emergency stop condition or power failure occurs. Take measures to prevent workpieces from dropping at such times.

### **2.3.4. Operation**

- Turn on the power to individual equipment one by one, starting from the equipment at the highest level in the system hierarchy. Failure to do so may cause the product to start suddenly, resulting in injury or product damage
- Do not insert a finger or object in the openings in the product. It may cause fire, electric shock, or injury.
- The motor incorporated into the product generates a large amount of heat during operation, and the product surface temperature is high. Take care not to affect the workpiece or other objects around the gripper.

### **2.3.5. Maintenance and Inspection**

Never touch terminals while performing insulation resistance test. Doing so may result in electric shock. (Do not perform dielectric strength test, because DC power is supplied with the product.)

### **2.3.6. Storage Environment**

The environment in which the gripper is stored must be:

- Not exposed to direct sunlight and moisture
- Be dark cool and 30 cm higher or more than the floor surface to prevent occurrence of dew condensation

- Be free from large vibration and impact

### **2.3.7. Disposal**

When the product no longer becomes usable or necessary, dispose of it properly as an industrial waste.

### 3. Handling Instructions and Precautions

#### 3.1. Names of the Parts

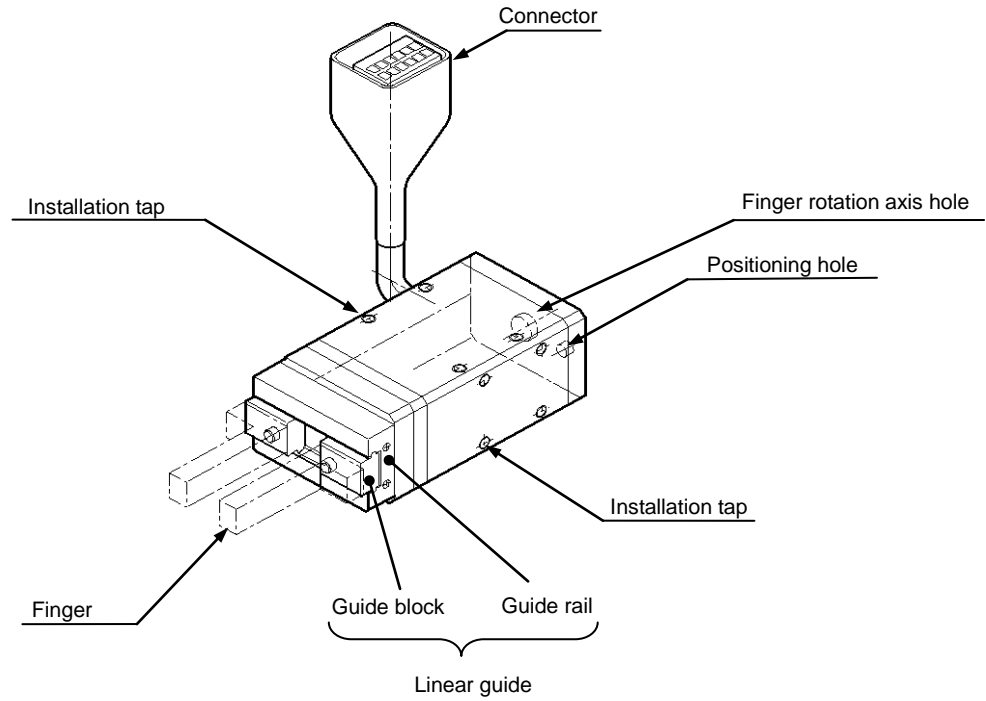

Fig. 1

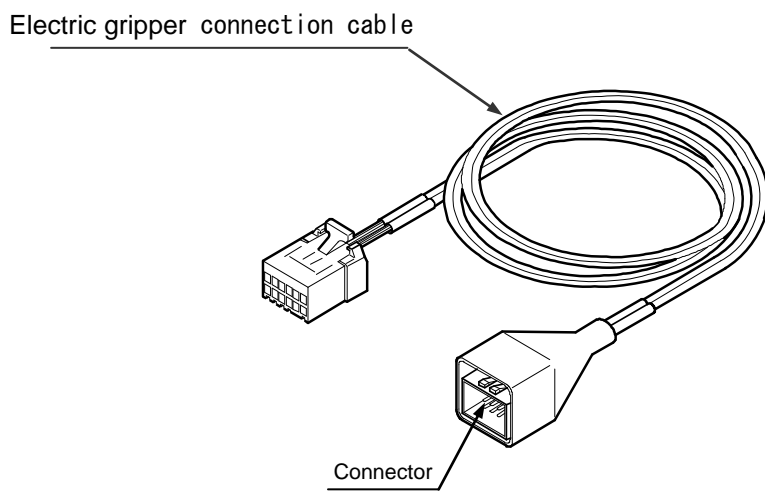

Fig. 2

## 3.2. Design

### 3.2.1. Design of Fingers

#### ! CAUTION

- Mount fingers not to exceed the allowable in the tables 1 and 1-1.
- Observe the limits of the mass, gripping point between finger installation surface and gripping point (L), and overhang (H) in the tables 1 and 1-1.

Table 1

				Single cam type			Double cam type			Screw type	
				SS-20	SS-28	SS-42	SD-20	SD-28	SD-42	F*-20	F*-28
Guide part	Allowable load	F	[N]	450	350	600	1000	1000	2000	1000	1300
	Allowable Pitching moment	M <sub>p</sub>	[N·m]	0.7	0.5	1.1	6.7	8.1	20.1	3.5	5
	Allowable Yawing moment	M <sub>y</sub>	[N·m]	0.8	0.6	1.3	4	4.8	12	4.2	6
	Allowable Rolling moment	M <sub>r</sub>	[N·m]	2.3	2.8	8.6	5.1	7.8	25.9	7.3	12.7
Finger	Max. mass (1 pair)		[g]	15	30	50	40	80	200	40	80
	Maximum gripping point	L	[mm]	20	20	25	30	30	50	30	30
	Maximum overhang	H	[mm]	20	25	30	20	20	30	20	20

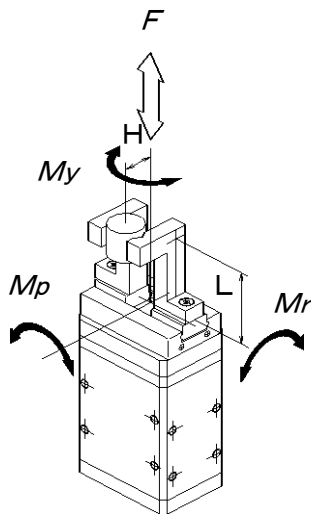

Fig. 3

				Single cam type	
				SS-2005-3N	SS-2005-5N
Guide part	Allowable load	F	[N]	12	
	Allowable pitching moment	M <sub>p</sub>	[N·m]	0.04	
	Allowable yawing moment	M <sub>y</sub>	[N·m]	0.04	
	Allowable rolling moment	M <sub>r</sub>	[N·m]	0.08	
Finger	Max. mass (1 pair)		[g]	10	
	Max. gripping point	L	[mm]	20	
	Max. overhang	H	[mm]	20	

Table 1-1

Note: Choose as short and lightweight finger as possible.

### 3.3. Selection

#### 3.3.1. Gripping Force vs Instruction Value

Gripping force can be adjusted freely according to instruction value. Refer to figures 4 to 6.

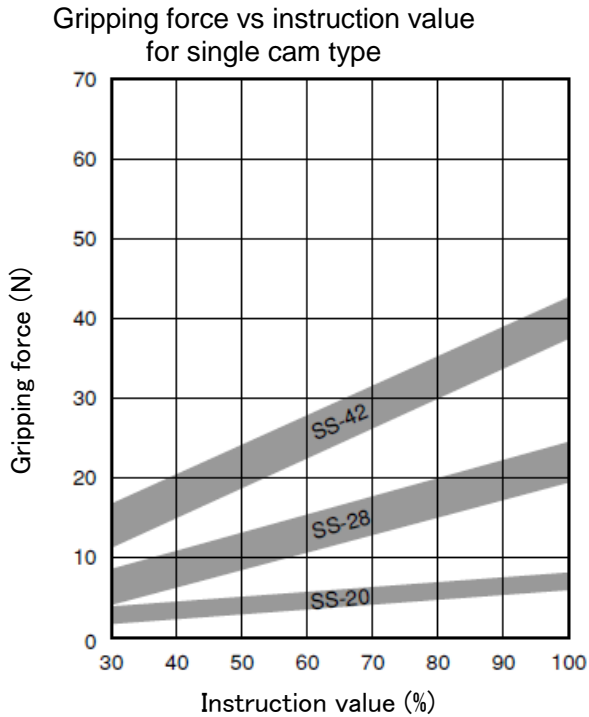

Fig. 4

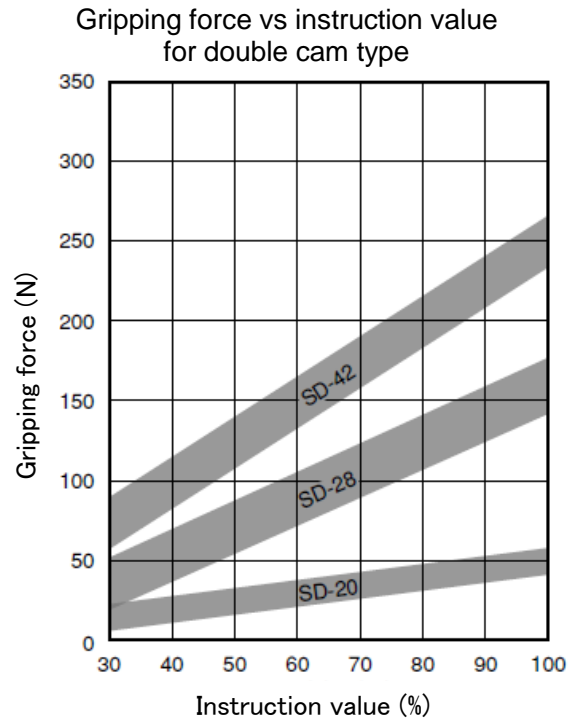

Fig. 5

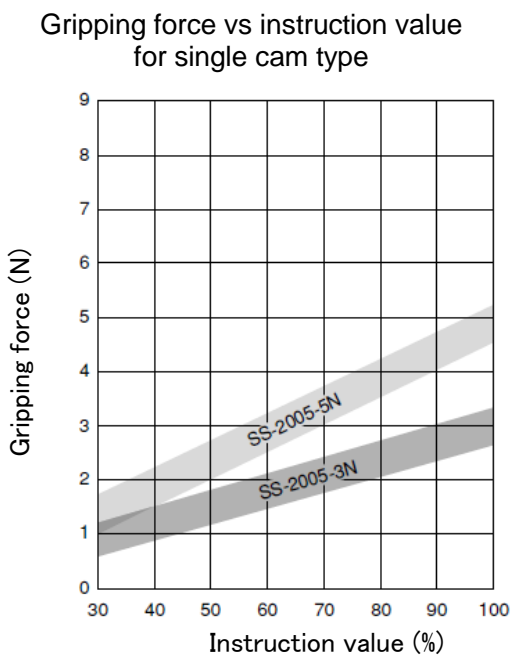

Fig. 4-1

#### ! CAUTION

- Use the charts between gripping force and instruction value for reference. There is variance in actual gripping force.
- Design so that mass of a gripped workpiece is approximately 1/10 to 1/20 of the gripping force.
- When the electric gripper is moved and revolved while it is gripping a workpiece, design operating ranges with ample margins from the ratings.
- Mass of a workpiece that the fingers can grip greatly differs depending on the material quality, shape, and gripping surface condition of the fingers.



Gripping force vs instruction value  
for screw type

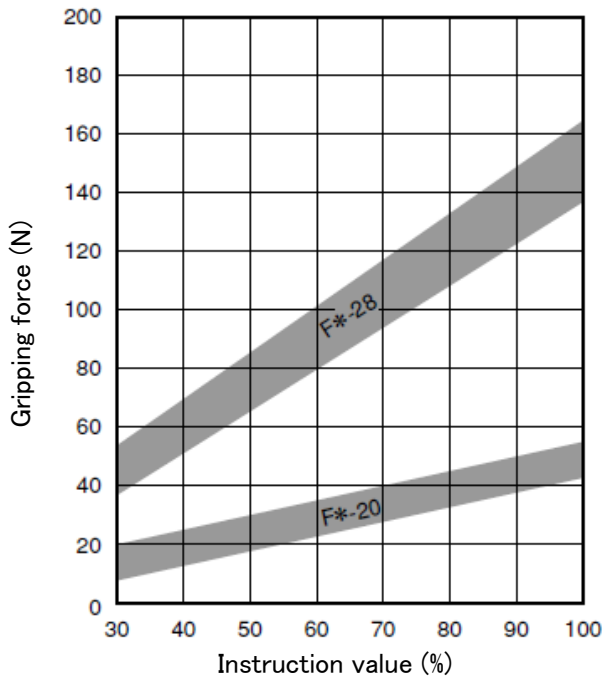

Fig. 6

**CAUTION**

- Use the charts between gripping force and instruction value for reference. There is variance in actual gripping force.
- Design so that mass of a gripped workpiece is approximately 1/10 to 1/20 of the gripping force.
- When the electric gripper is moved and revolved while it is gripping a workpiece, design operating ranges with ample margins from the ratings.
- Mass of a workpiece that the fingers can grip greatly differs depending on the material quality, shape, and gripping surface condition of the fingers.

## 3.4. Installation

### 3.4.1. Installation Bolts

**! WARNING**

- Surely fix the product by use of the four installation taps in each mounting surface.
- Material of installation tap is aluminum. Applying excessive high torque to the installation bolts may cause damage to the taps and loose bolt. This may lead to personal injuries. Apply proper torque to the bolts and take measures to prevent loose bolt.
- Installation taps on the guide block are pass-through holes. If a bolt that is deep enough to be inserted beyond the effective depth of hole of the electric gripper is used, it may reach to the guide rail. This may cause damage to the parts in the product. Never use any bolt that is longer than the effective depth of hole of the electric gripper. The effective depths of the installation taps are distinct from each mounting surfaces. Please refer to [Mounting surfaces and fixing taps](#) which starts from the next page

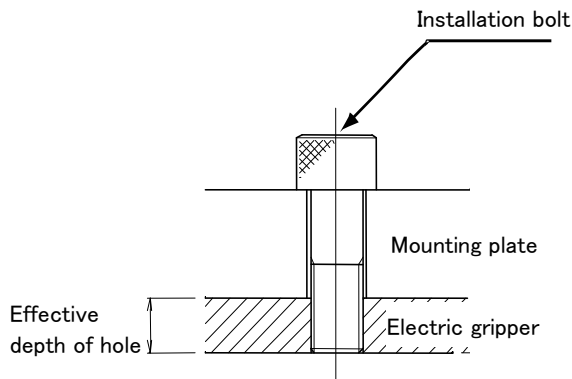

Fig. 7

Type	Tap	Recommended tightening torque (N·m)
SX-20	M3	0.55~0.70
SS-2005		
SX-28	M4	1.15~1.55
SX-42	M5	2.65~3.20
FX-20	M4	1.15~1.55
FX-28	M5	2.65~3.20

**! CAUTION**

Recommended tightening torque in the table above is generally used one. Take material quality of your installation bolts and flanges into consideration and decide tightening torque.

### **3.4.2. Mounting surface**



Be sure to mount the product onto the flat surface.

Single cam type (SS) and double cam type (SD) have five mounting surfaces, and screw type (FT/FS) has three mounting surfaces; therefore, the gripper can flexibly installed. (SS-2005 has only two mounting surfaces.) In the opposite surface of the fingers mounting surface, rotation axis hole for fingers and positioning holes are provided.

**Mounting surfaces and fixing taps**

Single/Double cam type

Installation dimensions of single/double com type are the same.

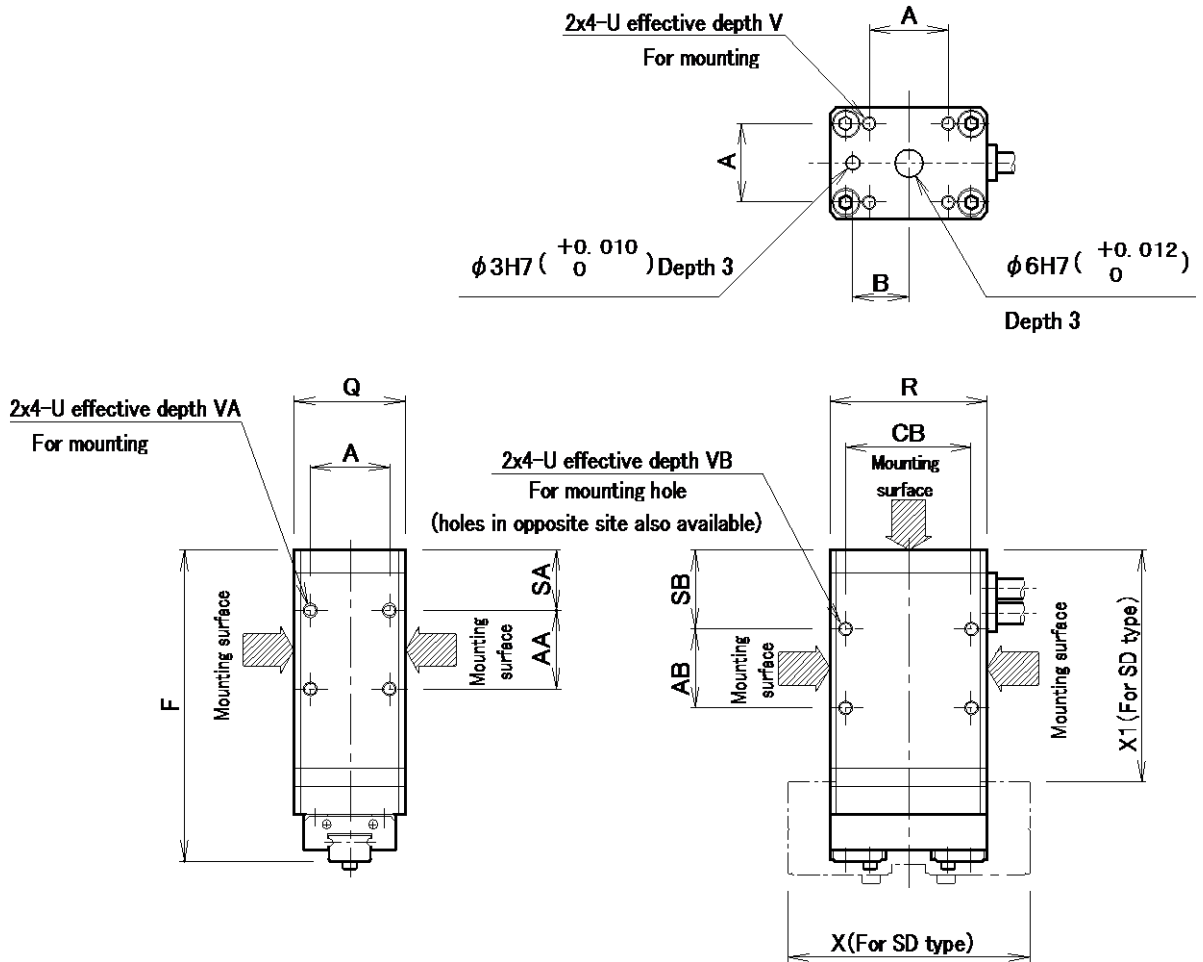

Fig. 8

Unit: mm

Model	A	AA	AB	B	CB	F	Q	R	SA	SB	U	V	VA	VB	X	X1
DRH-ESG1-SX-20XX	17	17	17	12	27	71	24	34	13	17	M3	5	6	6	52	54
DRH-ESG1-SX-28XX	24	24	14	15	38	78	32	46	16	21	M4	6	8	8	67	61
DRH-ESG1-SX-42XX	36	25	13	20	50	86	46	60	18	24	M5	7.5	8	10	96	62

DRH-ESG1-SS-2005-3N·5N

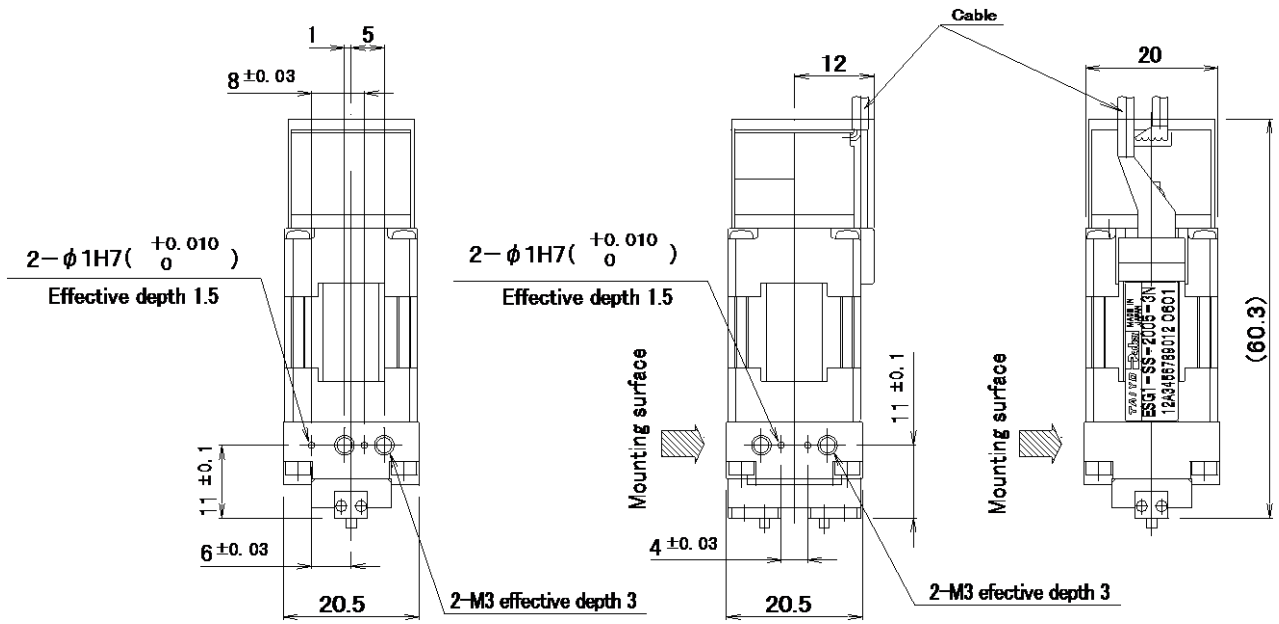

Fig. 8-1

Note: DRH-ESG1-SS-2005-3N·5N have only two installation surfaces.

Screw type

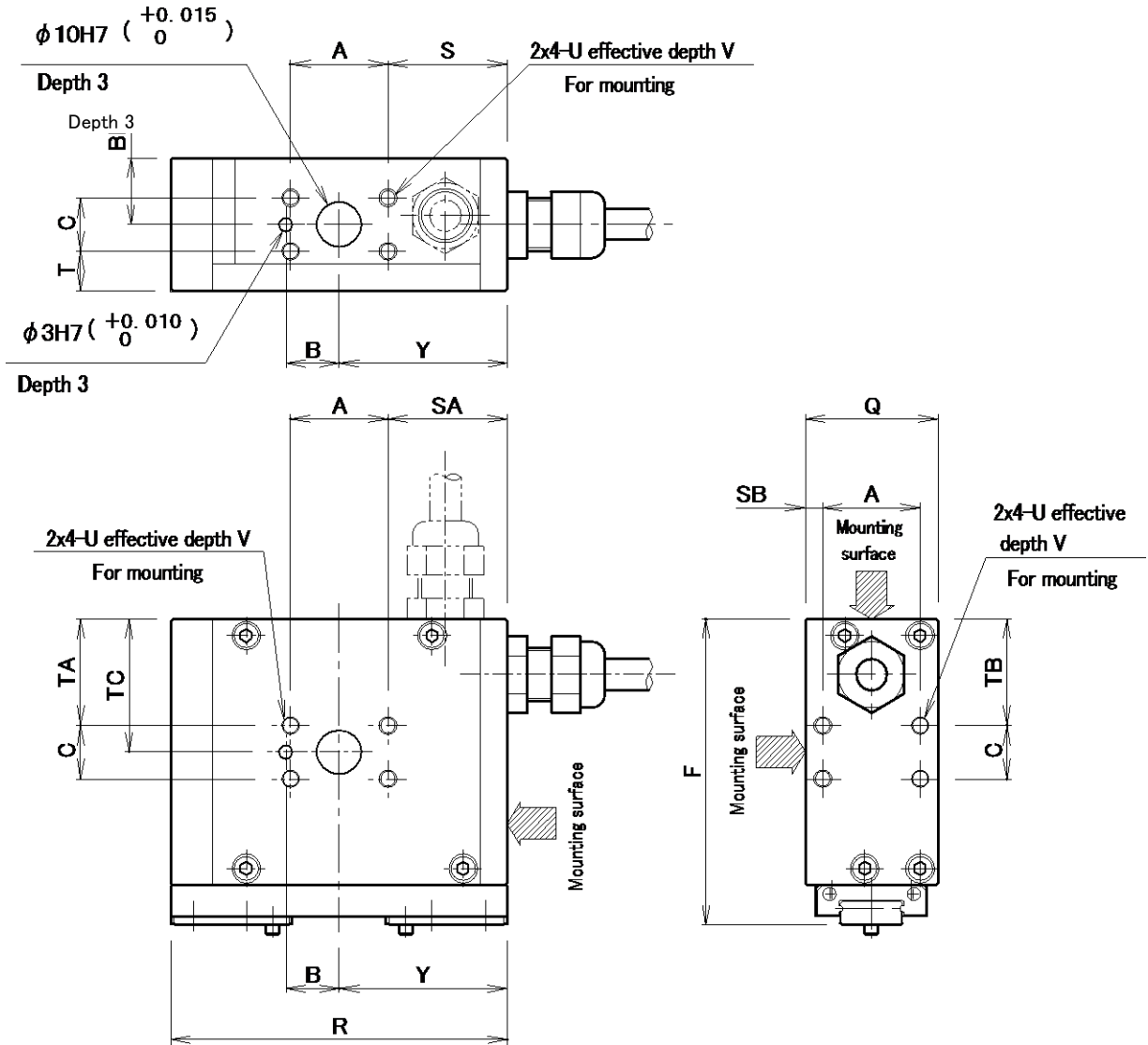

Fig. 9

Unit: mm

Model	A	B	BD	C	F	Q	R	S	SA	SB	T	TA	TB	TC	U	V	Y
DRH-ESG1-F S-20XX	22	12	15	12	69	30	76	27	27	4	9	24	24	30	M4	6	38
DRH-ESG1-F S-28XX	30	15	20	16	84	40	110	40	40	5	12	28	28	36	M5	7.5	55

Screw type

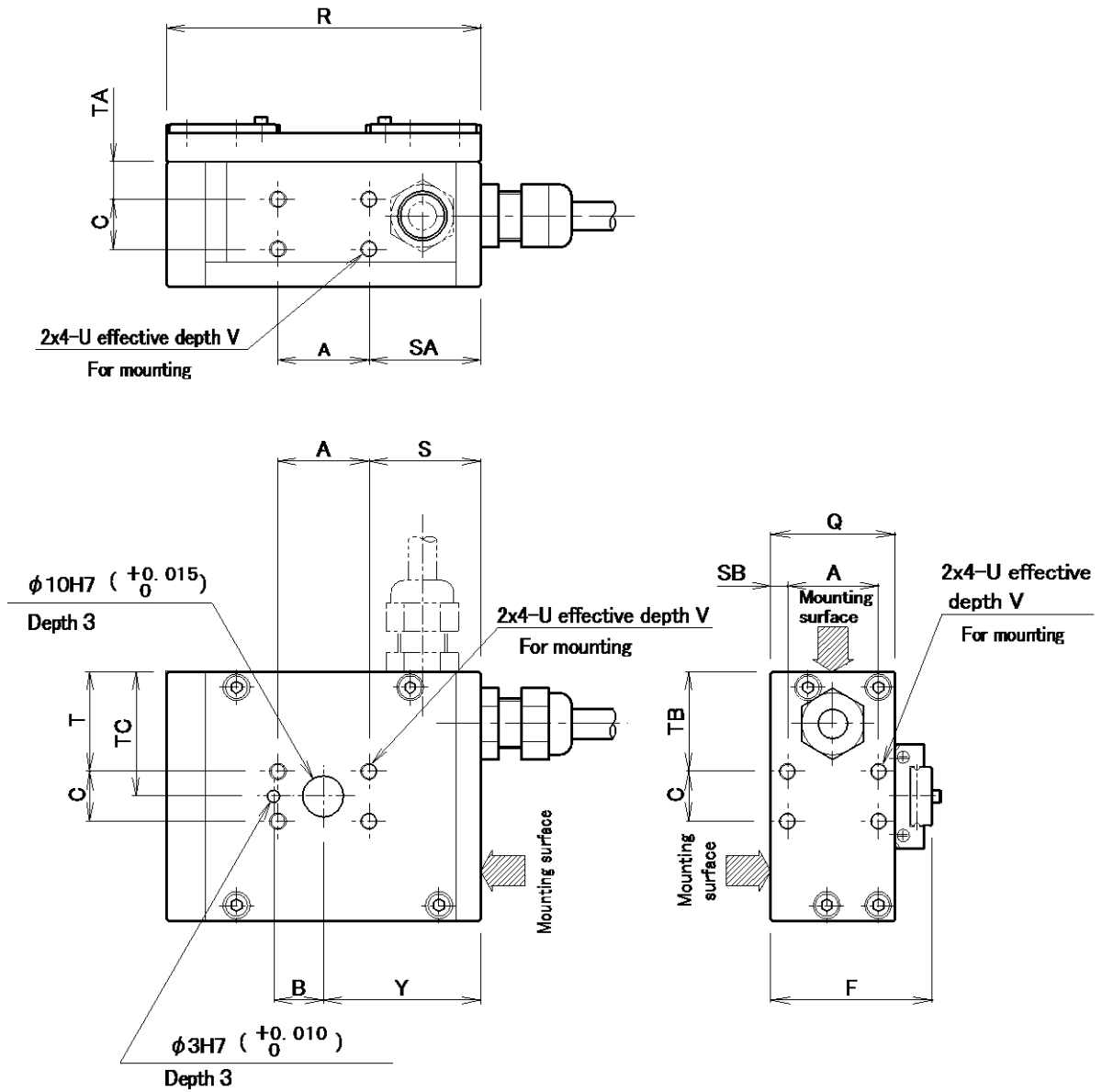

Fig. 10

Unit: mm

Model	A	B	C	F	Q	R	S	SA	SB	T	TA	TB	TC	U	V	Y
DRH-ESG1-FT-20XX	22	12	12	39	30	76	27	27	4	24	9	24	30	M4	6	38
DRH-ESG1-FT-28XX	30	15	16	52	40	110	40	40	5	28	12	28	36	M5	7.5	55

## Installing the Fingers

### ! CAUTION

- When installing and uninstalling the fingers, surely support them to prevent applying excessive force to or impacting on the guide block.
- This may cause damage to the parts in the product. The tapped holes used for installing the fingers are through holes. Therefore, never use long screws exceeding the effective thread length. They may damage the product.

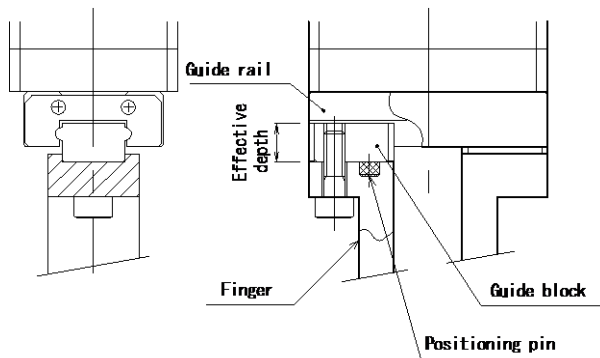
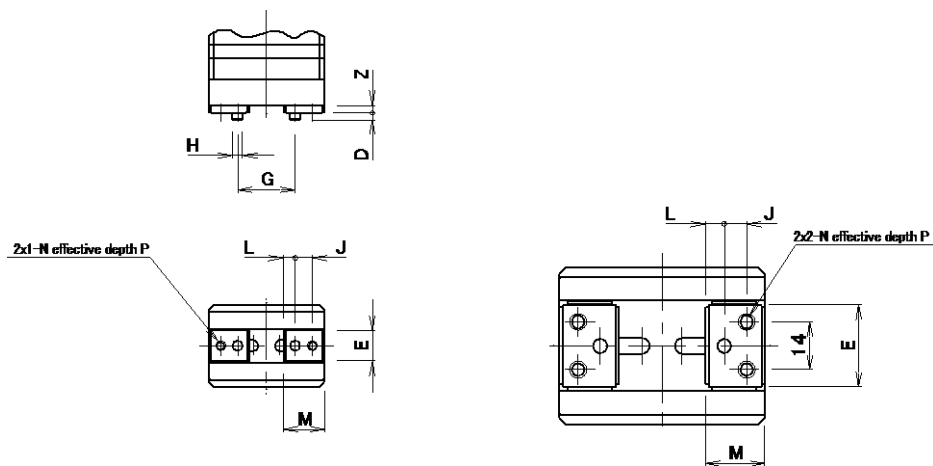

Fig. 11

Using the positioning pin on the guide block may improve installation accuracy and repeatability. For further improvement of installation repeatability, place a guide block between a finger and guide rail as the figure 11.

## Installation Dimensions of Fingers

### Single cam type



For SS42 type

Fig. 12

Unit: mm

Model	D	E	G	H	J	L	M	N	P	Z
DRH-ESG1-SS-20XX	2	9 <sup>0.05</sup> <sub>0</sub>	8.4~16	φ3 <sup>0.01</sup> <sub>0</sub>	5	3.5	12.1	M3	5	2.2
DRH-ESG1-SS-2005-XN	1.5	5± <sup>0.025</sup>	5.8~9	φ1.5 <sup>0.01</sup> <sub>0</sub>	3	2.5	8	M2	3.5	1.5
DRH-ESG1-SS-28XX	2	14 <sup>0.05</sup> <sub>0</sub>	9.6~23.9	φ3 <sup>0.01</sup> <sub>0</sub>	6	4.3	15	M4	5	2
DRH-ESG1-SS-42XX	3	24 <sup>0.05</sup> <sub>0</sub>	12~35.5	φ4 <sup>0.012</sup> <sub>0</sub>	6.5	5.5	17.4	M5	8	3



Double cam type

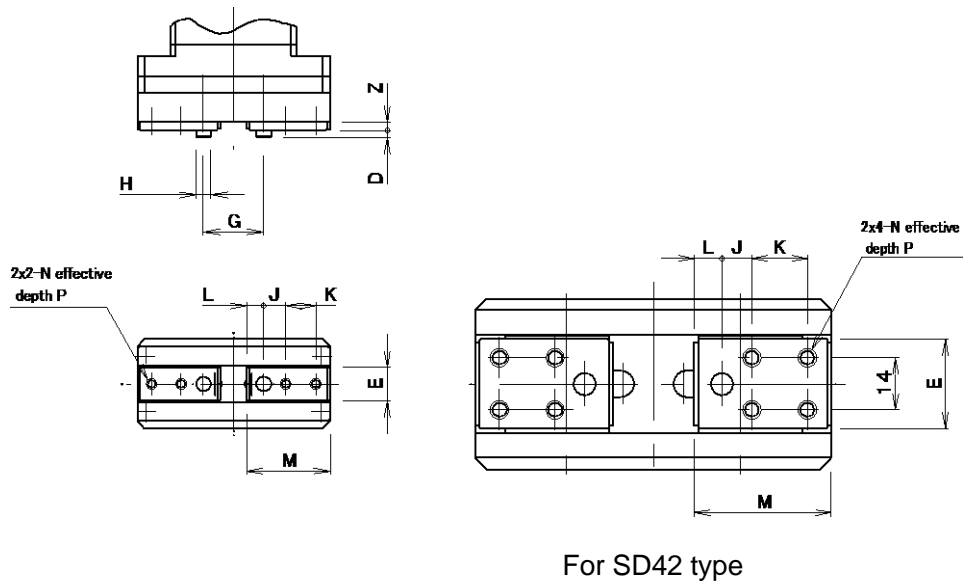

Fig. 13

Unit: mm

Model	D	E	G	H	J	K	L	M	N	P	Z
DRH-ESG1-SD-20XX	2	$9_{-0.05}^0$	10.6~15.6	$\phi 4_{-0.01}^0$	6	8	4.6	22.5	M3	5	2.2
DRH-ESG1-SD-28XX	2	$14_{-0.05}^0$	12.6~22.6	$\phi 5_{-0.012}^0$	7	10	5.65	27.5	M4	5	2
DRH-ESG1-SD-42XX	3	$24_{-0.05}^0$	17.0~36.3	$\phi 6_{-0.015}^0$	8	15	7.5	37	M5	8	3

Screw type

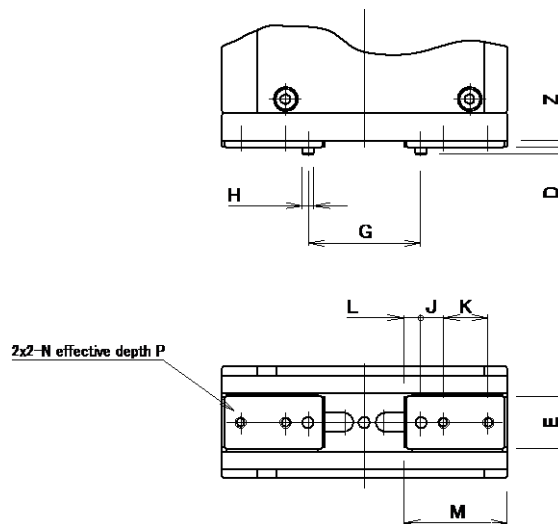

Fig. 14

Unit: mm

Model	D	E	G	H	J	K	L	M	N	P	Z
DRH-ESG1-FX-20XX	2	$14_{-0.05}^0$	10.5~29.5	$\phi 3_{-0.01}^0$	6	12	4.5	27.5	M3	5	2
DRH-ESG1-FX-28XX	2	$18_{-0.05}^0$	13.0~51.0	$\phi 4_{-0.012}^0$	8	14	5.5	34.5	M4	7.5	3

### **3.4.3. Connecting the Electric Gripper Connection Cable**

Refer to the “Electric Gripper Control Board Operation Manual” for details on connecting the electric gripper and electric gripper control board.

#### **! WARNING**

Always ensure that the electric gripper control board and robot controller power has been turned OFF before connecting or disconnecting the electric gripper connection cable.

If connected or disconnected with the power ON, the electric gripper may malfunction, resulting in possible damage to the unit, and or physical injury.

Before connecting the motor cable, check for scratches on the cable and bent connector pins. Be sure to use the supplied motor cable.

Never cut and/or reconnect the cables supplied with the product for the purpose of extending or shortening the cable length.

#### **! CAUTION**

The highly flexible electric gripper connection cable is used for connecting between the gripper and the controller. When connecting the electric gripper connection cable, be sure to observe the followings:

- Do not let the cable flex at a single point to minimize the curvature.
- Do not let the cable get tangled or kinked.
- Do not pull the cable with a strong force.
- When fixing the cable, provide a moderate slack and do not tension it too tight.
- Do not scratch the cable.

Be sure to fix the cable coming out of the electric gripper.

### 3.4.4. System Configuration

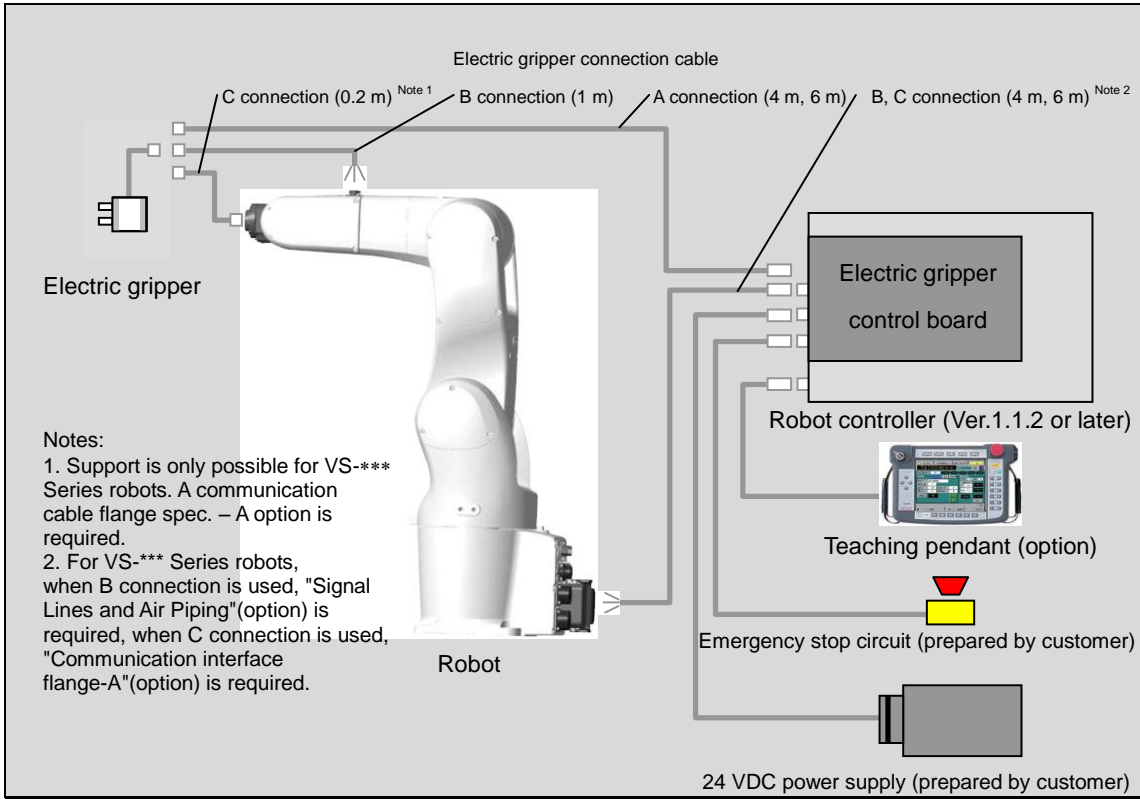

## 3.5. Trial Run and Adjustment

### 3.5.1. Setting Operation Mode

All parameters, operating modes, and point data are set with the electric gripper screen of the teach pendant.

Refer to the Electric Gripper Control Board Operation Manual or Electric Gripper command Instruction Manual for specific details on how to perform operation.

#### WARNING

Set parameters and operation mode not to impact excessively on or apply moment to the fingers while in operation. The product may be damaged or its service life may be shortened.

### 3.5.2. Operating with electric gripper command

All point operations can be performed individually with the electric gripper command.

Refer to the Electric Gripper command Instruction Manual.

### 3.5.3. Removing a Workpiece

#### CAUTION

Self lock function is not available in single cam type (SS). The fingers can be moved by hand while the power is off.

The screw type (FT/FS) and double-cam type (SD) have a reduction gear system, and therefore fingers cannot be moved by hand. Therefore if removing workpieces when turning OFF the power, do so by removing the fingers. Do not attempt to remove the workpiece or open between the fingers forcibly. The gripper may be damaged. Remove the workpiece while the gripper is not in use for long time. If the gripper is left unused for long time with the gripper holding a workpiece, the slide may be negatively affected.

### **3.6. Maintenance and Inspection**

Daily and periodic inspections are essential to making sure your gripper will operate safely and efficiently.

#### **3.6.1. Inspection Timings and Items**

Inspection	Timing	Items
Daily Inspection	Daily (at start of operation)	Visual inspection Check for correct operations
Periodical Inspection	Every six months after start of operation	Grease supply
Others	As needed	External cleansing

#### **3.6.2. Procedure for Visual Inspection**

Check the following for external inspection.

Inspection point	What to be inspected	Troubleshooting
Electric gripper	Installation bolts are not loose. Fingers are firmly attached.	If you find the loose installation bolts, tighten them by applying the specified torque and take measures to prevent loosening.
Electric gripper connection cable	Connectors are surely connected. There are no flaws. There are no scratches on the moving parts.	If there are flaws and/or scratches on the electric hand connection cable, replace it and eliminate the cause.

#### **3.6.3. Conducting Operation Check**

Check for abnormal noise, vibration, and smooth operation. If any abnormalities are detected, stop the operation immediately.

#### **3.6.4. Reapplication of Grease**

##### **! Warning**

- Apply proper amount of grease to the prescribed points on the gripper. Electric devices such as a stepping motor or rotary encoder exist in the gripper. Accidental application of grease to the parts may result in unavailability of exhibition of full performance, malfunction, damage of mechanical device and physical accident.
- Do not use spray grease. Flying grease may come in contact with the encoder.
- Never use fluorine grease. If fluorine grease is mixed with lithium grease, the lubricating function of grease will drop and the electric gripper may suffer damage.
- Do not use spray oil, because it may cause grease to wash out, resulting in lubrication failure. It may also travel to the unexpected parts and cause them to malfunction.
- When disassembling and reassembling the gripper to add grease, be sure to observe the specified instructions. Failure to do so may result in product malfunction or damage.

##### **Applicable Grease**

Multemp PSNo.2 (KYODO USHI) or equivalent product (lithium grease)

Applying Grease to the Guide Par

⚠ Caution

Apply the specified grease to the space between the guide block and guide rail (to four ball screws) with an injection device.

After application of grease, wipe off unnecessary grease around the guide part.

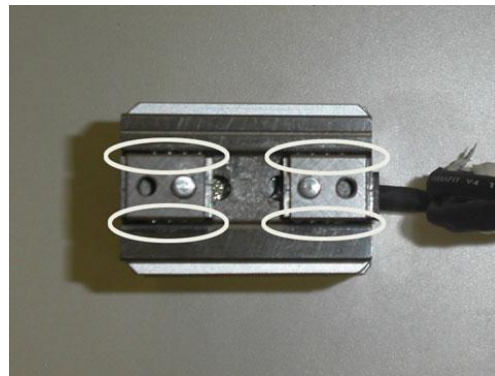
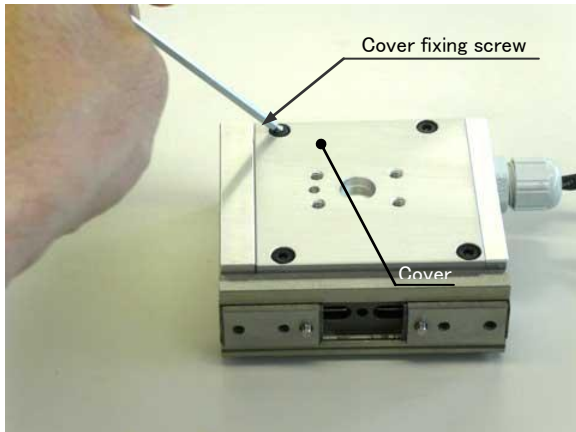

Fig. 16

### Applying Grease to the Ball Screws



- ① For easier application of grease, open the guide block first.
- ② Unscrews and remove the cover.
- ③ Apply proper amount of grease on the surface of ball screws with fingers.
- ④ Screw the cover at recommended torque level.

Cover fixing screw size and recommended tightening torque



Model	Screw size	Recommended tightening torque (N·m)
DRH-ESG1-FX-20XX	M3 × 6	0.55~0.70
DRH-ESG1-FX-28XX	M4 × 10	1.15~1.55

Fig. 17

### 3.6.5. Cleaning Outside of the Gripper

#### ⚠ CAUTION

Wipe dirt with soft cloth to prevent dust flying

To clean stubborn soiling, moisten a soft cloth, etc., with neutral detergent. Care should be taken not to prevent water droplets on the surface of the ball screws from rusting the product.

Do not blow compressed air onto the electric gripper too strongly to prevent dust from entering the electric gripper through small openings and gaps.



## 4. Specifications

### Cam type

Type			Single					Double		
			SS-20	SS-28	SS-42	SS-2005-3N	SS-2005-5N	SD-20	SD-28	SD-42
Gripping force	Max. rating continuous	[N]	6	22	40	3.1	5.1	50	150	250
	Minimum setting	[%](N)	30(1.8)	30(6.6)	34(13.5)	0.9	1.5	30(15)	30(45)	30(75)
	Resolution	[%](N)	1(0.06)	1(0.22)	1(0.45)	1(0.03)	1(0.05)	1(0.5)	1(1.5)	1(2.5)
Open/close stroke		[mm]	7.6	14.3	23.5	3.2		5	10	19.3
Speed	Max (Rating)	[mm/sec]	100	100	100	100		60	60	45
	Min. setting	[%] (mm/sec)	20(20)	20(20)	20(20)	20(20)		20(12)	20(12)	20(9)
	Resolution	[%] (mm/sec)	1(1)	1(1)	1(1)	1(1)	1(1)	1(0.6)	1(0.7)	1(0.45)
	Constant-speed move and grip (max)	[%]	50	50	50	50	50	50	50	50
Position	Repeatability	[mm]	±0.02	±0.02	±0.02	±0.03	±0.02	±0.03	±0.03	±0.03
Finger	Max. mass (1 pair)	[g]	15	30	50	10	10	40	80	200
	Allowable load	[N]	450	350	600	12		1000	1000	2000
	Allowable pitching moment	[N·m]	0.7	0.5	1.1	0.04		6.7	8.1	20.1
	Allowable yawing moment	[N·m]	0.8	0.6	1.3	0.04		4	4.8	12
	Allowable rolling moment	[N·m]	2.3	2.8	8.6	0.08		5.1	7.8	25.9
	Max. gripping point	[mm]	20	20	25	20		30	30	50
	Max. overhang	[mm]	20	25	30	20		20	20	30
Guide structure			Linear guide							
Max. gripping mass	[%](kg)		10 (0.06)	10 (0.22)	10 (0.45)	10 (0.03)	10 (0.05)	10(0.5)	10(1.5)	10 (2.5)
Operating temperature range	[°C]	0~40								
Operating humidity range	[%]	RH35~90								
Operating storage temperature	[°C]	-10~60								
Mass	[g]		160	300	580	90		200	350	800

## Screw type

Type			Screw type			
			FS-20	FT-20	FS-28	FT-28
Gripping force	Max. continuous rating	[N]	50		150	
	Minimum setting	[%](N)	30(15)		30(45)	
	Resolution	[%](N)	1(0.5)		1(1.5)	
Open/close stroke		[mm]	19		38	
Speed	Max (Rating)	[mm/sec]	50		50	
	Minimum setting	[%] (mm/sec)	20(10)		20(10)	
	Resolution	[%] (mm/sec)	1(0.5)		1(0.5)	
	Low-speed gripping mode (max.)	[%]	50		50	
Position	Repeatability	[mm]	±0.01		±0.01	
Finger	Maximum mass (1 pair)	[g]	40		80	
	Allowable load	[N]	1000		1300	
	Allowable pitching moment	[N·m]	3.5		5	
	Allowable yawing moment	[N·m]	4.2		6	
	Allowable rolling moment	[N·m]	7.3		12.7	
	Max. gripping point	[mm]	30		30	
	Max. overhang	[mm]	20		20	
Guide structure			Linear guide			
Max. gripping mass		[%](kg)	10(0.5)		10(1.5)	
Operating temperature range		[°C]	0~40			
Operating humidity range		[%]	RH35~90			
Operating storage temperature		[°C]	-10~60			
Mass		[g]	420	420	880	890

## 5. External Dimensions

Single Cam : SS

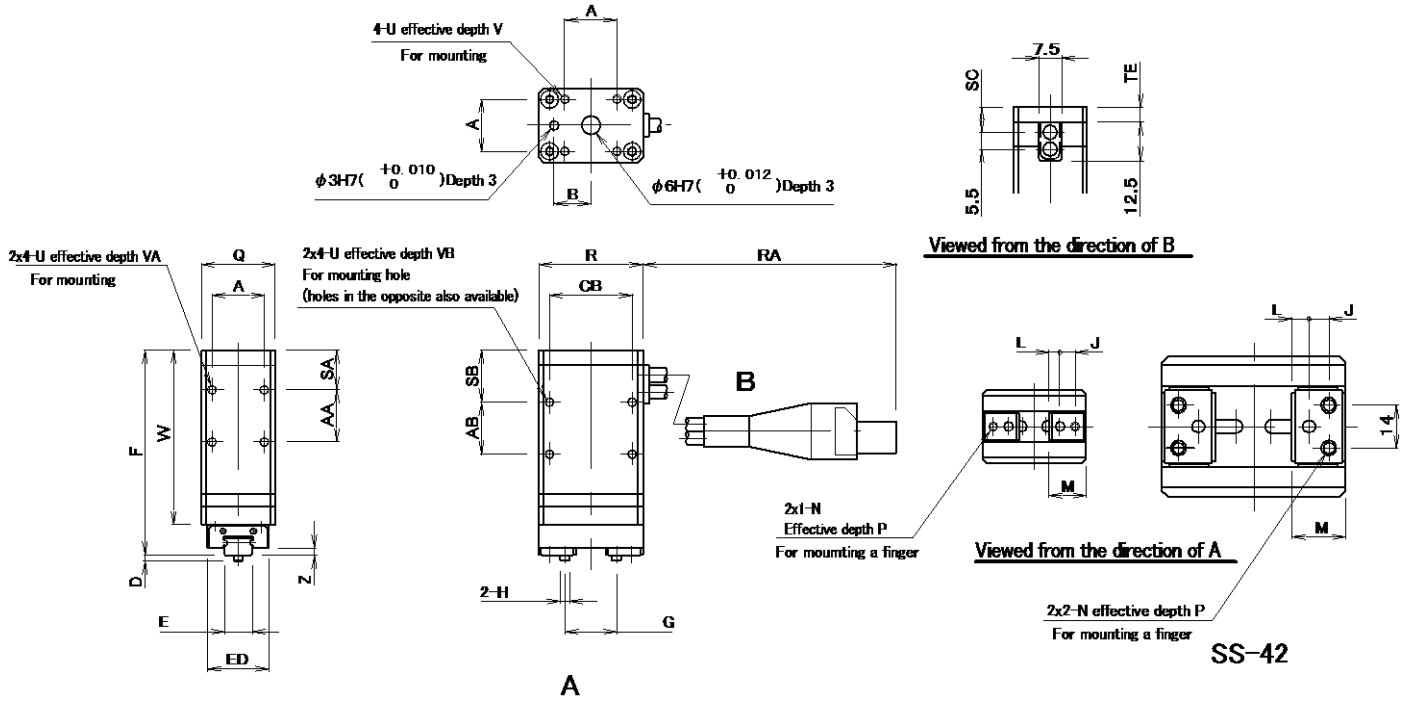

Fig. 18

Unit: mm

	A	AA	AB	B	CB	D	E	ED	F	G	H
DRH-ESG1-SS-20XX	17	17	17	12	27	2	$9_{-0.05}^0$	20	71	8.4~16	$\phi 3_{-0.01}^0$
DRH-ESG1-SS-28XX	24	24	14	15	38	2	$14_{-0.05}^0$	25	78	9.6~23.9	$\phi 3_{-0.01}^0$
DRH-ESG1-SS-42XX	36	25	13	20	50	3	$24_{-0.05}^0$	40	86	12~35.5	$\phi 4_{-0.012}^0$

	J	L	M	N	P	Q	R	RA	SA	SB	SC	TE	U
DRH-ESG1-SS-20XX	5	3.5	12.1	M3	5	24	34	165±10	13	17	8.3	5	M3
DRH-ESG1-SS-28XX	6	4.3	15	M4	5	32	46	140±10	16	21	9.3	6	M4
DRH-ESG1-SS-42XX	6.5	5.5	17.4	M5	8	46	60	235±10	18	24	10.8	7.5	M5

	V	VA	VB	W	Z
DRH-ESG1-SS-20XX	5	6	6	61	2.2
DRH-ESG1-SS-28XX	6	8	8	69	2
DRH-ESG1-SS-42XX	7.5	8	10	72	3

Single Cam: DRH-ESG1-SS-2005-3N·5N

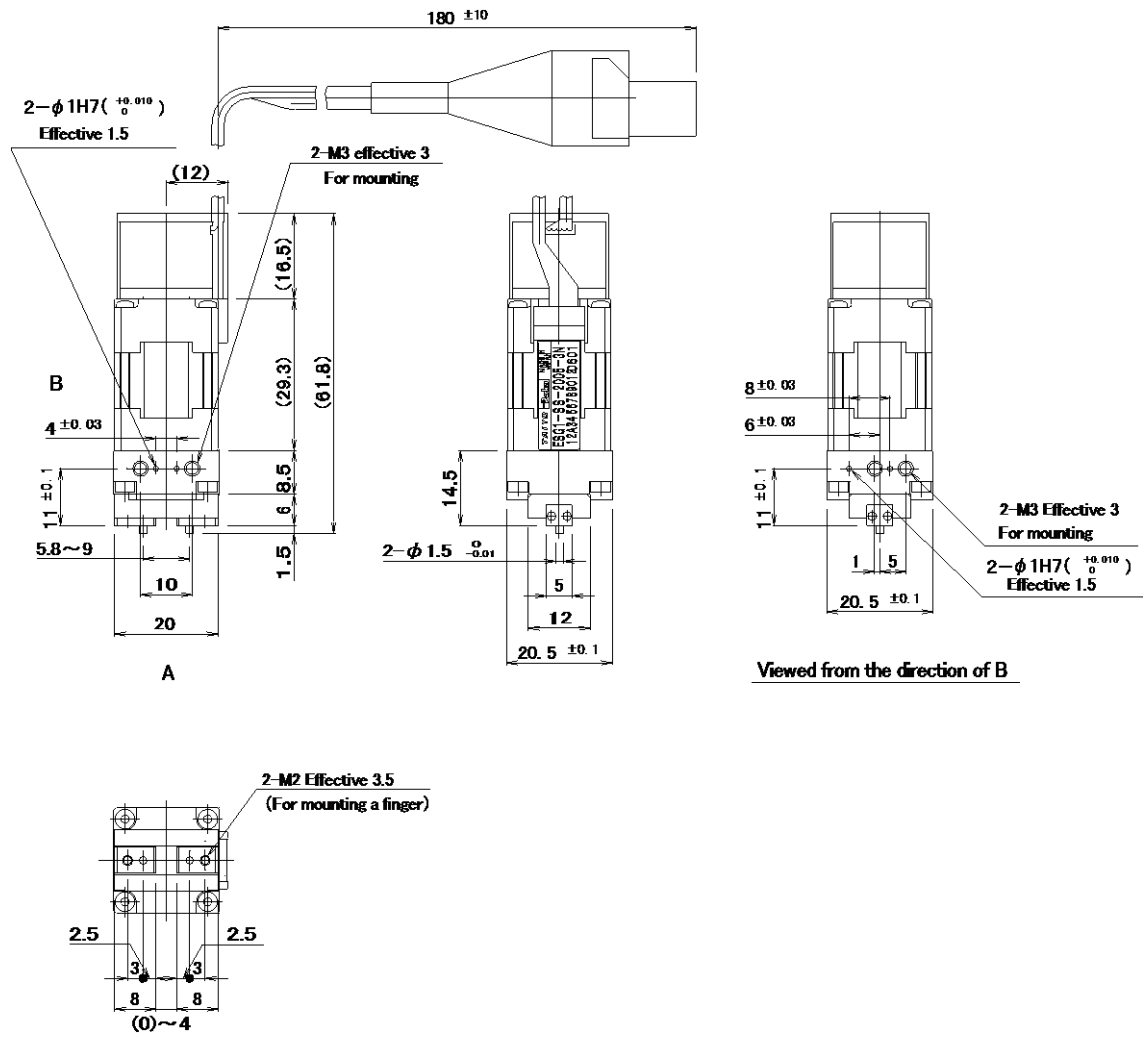

Fig. 18-1

### Double Cam: SD

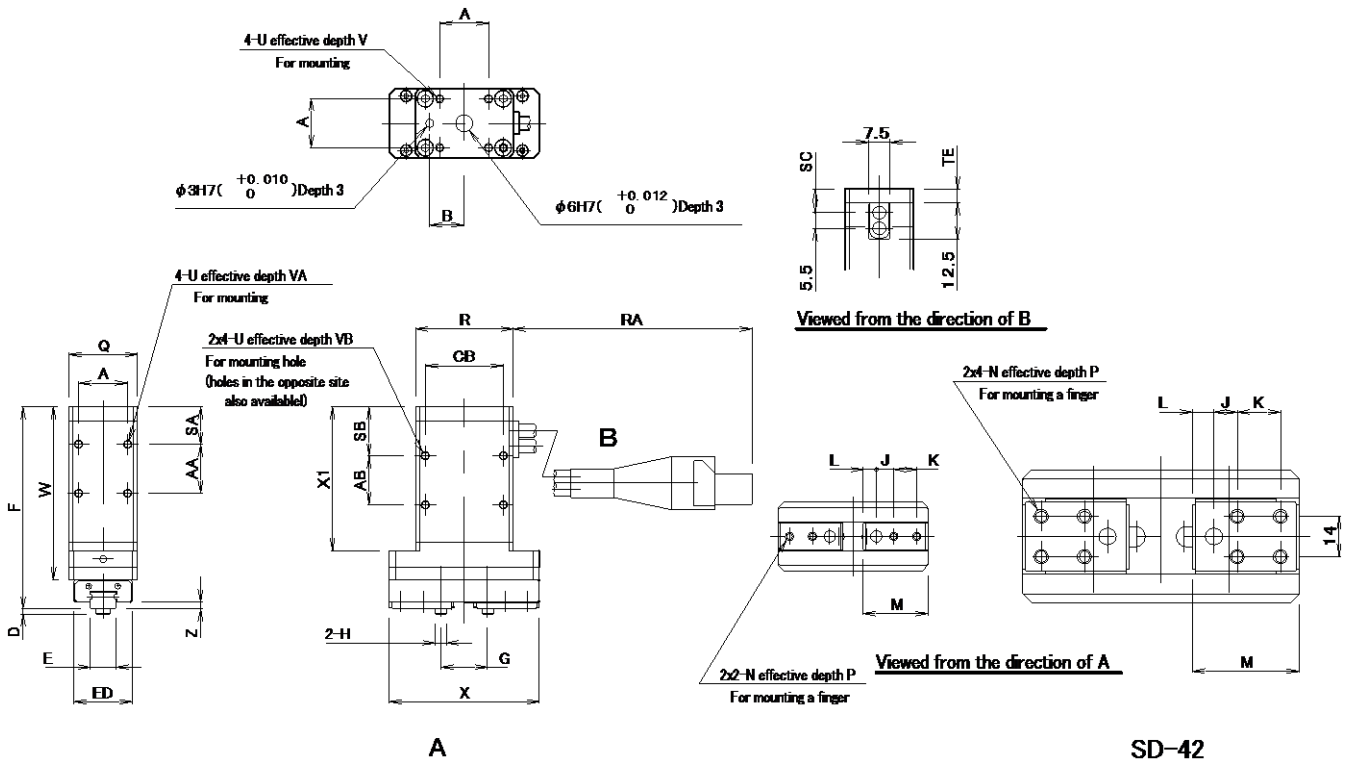

Fig. 19

Unit: mm

Model	A	AA	AB	B	CB	D	E	ED	F	G	H	J
DRH-ESG1-SD-20XX	17	17	17	12	27	2	$9_{-0.05}^0$	20	74	10.6~15.6	$\phi 4_{-0.01}^0$	6
DRH-ESG1-SD-28XX	24	24	14	15	38	2	$14_{-0.05}^0$	25	80	12.6~22.6	$\phi 5_{-0.012}^0$	7
DRH-ESG1-SD-42XX	36	25	13	20	50	3	$24_{-0.05}^0$	40	89	17.0~36.3	$\phi 6_{-0.015}^0$	8

Model	K	L	M	N	P	Q	R	RA	SA	SB	SC	TE	U	V
DRH-ESG1-SD-20XX	8	4.6	22.5	M3	5	24	34	165±10	13	17	8.3	5	M3	5
DRH-ESG1-SD-28XX	10	5.65	27.5	M4	5	32	46	140±10	16	21	9.3	6	M4	6
DRH-ESG1-SD-42XX	15	7.5	37	M5	8	46	60	235±10	18	24	10.8	7.5	M5	7.5

Model	VA	VB	W	X	X1	Z
DRH-ESG1-SD-20XX	6	6	64	52	54	2.2
DRH-ESG1-SD-28XX	8	8	71	67	61	2
DRH-ESG1-SD-42XX	8	10	75	96	62	3

Screw type: FS

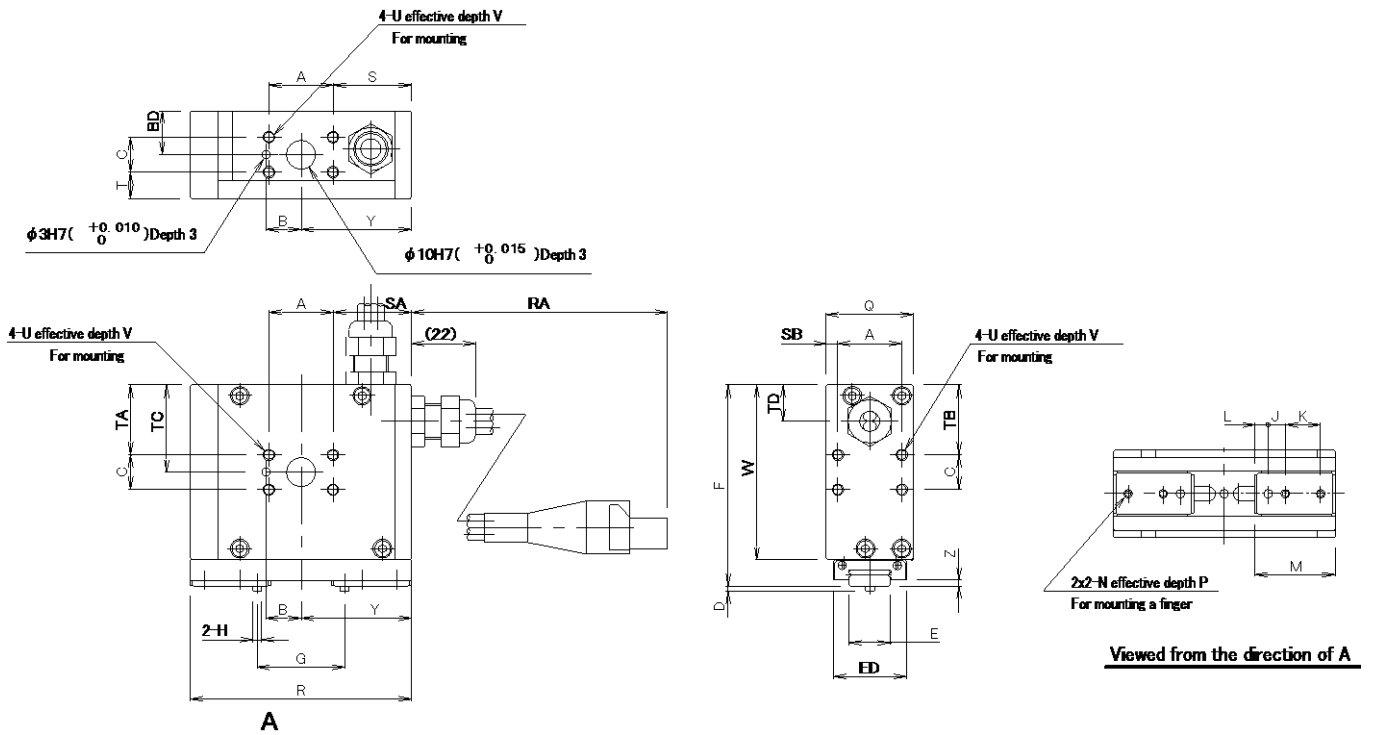

Fig 20

Unit: mm

Model	A	B	BD	C	D	E	ED	F	G	H	J
DRH-ESG1-FS-20XX	22	12	15	12	2	$14_{-0.05}^0$	25	69	10.5~29.5	$\phi 3_{-0.01}^0$	6
DRH-ESG1-FS-28XX	30	15	20	16	2	$18_{-0.05}^0$	30	84	13~51	$\phi 4_{-0.012}^0$	8

Model	K	L	M	N	P	Q	R	RA	S	SA	SB	T	TA
DRH-ESG1-FS-20XX	12	4.5	27.5	M3	5	30	76	175±10	27	27	4	9	24
DRH-ESG1-FS-28XX	14	5.5	34.5	M4	7.5	40	110	135±10	40	40	5	12	28

Model	TB	TC	TD	U	V	W	Y	Z
DRH-ESG1-FS-20XX	24	30	12.5	M4	6	60	38	2
DRH-ESG1-FS-28XX	28	36	14	M5	7.5	72	55	3

Screw type: FT

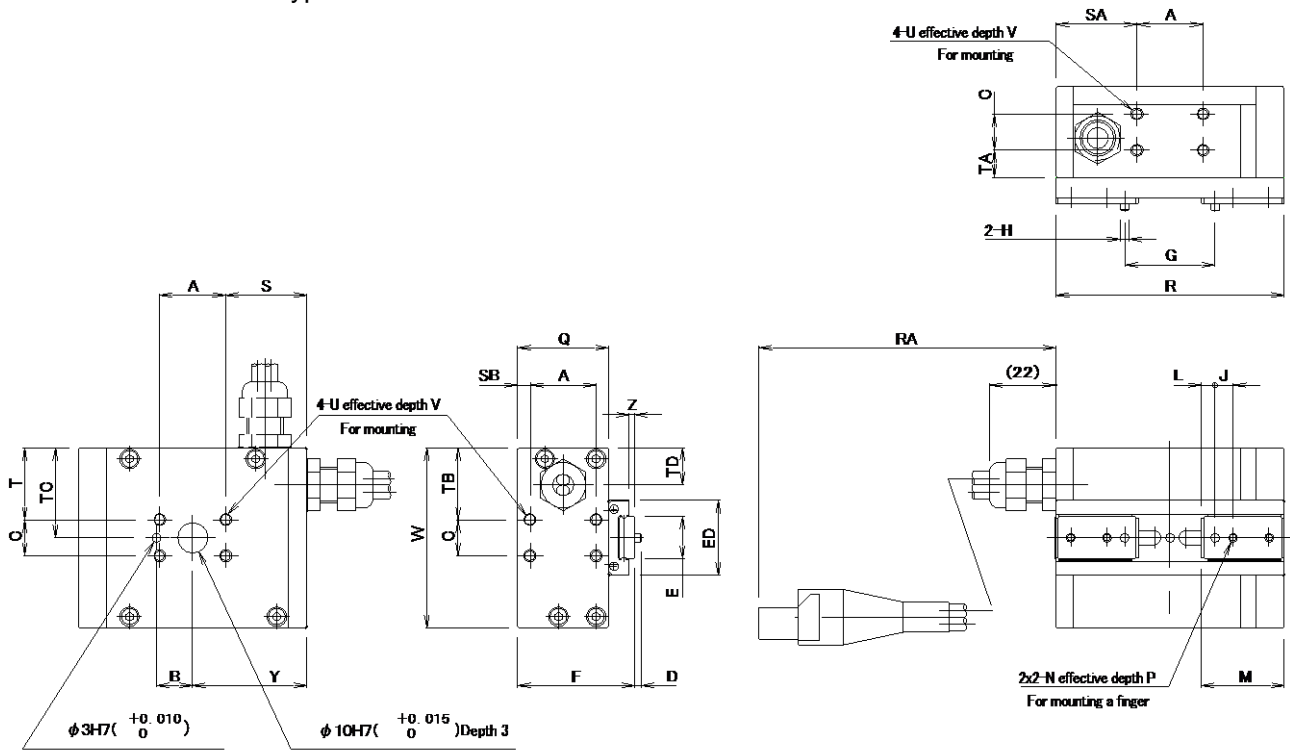

Fig. 21

Unit: mm

Model	A	B	C	D	E	ED	F	G	H	J	K
DRH-ESG1-FT-20XX	22	12	12	2	14 <sup>0</sup> <sub>-0.05</sub>	25	39	10.5~29.5	φ 3 <sup>0</sup> <sub>-0.01</sub>	6	12
DRH-ESG1-FT-28XX	30	15	16	2	18 <sup>0</sup> <sub>-0.05</sub>	30	52	13~51	φ 4 <sup>0</sup> <sub>-0.012</sub>	8	14

Model	L	M	N	P	Q	R	RA	S	SA	SB	T	TA	TB
DRH-ESG1-FT-20XX	4.5	27.5	M3	5	30	76	175±10	27	27	4	24	9	24
DRH-ESG1-FT-28XX	5.5	34.5	M4	7.5	40	110	135±10	40	40	5	28	12	28

Model	TC	TD	U	V	W	Y	Z
DRH-ESG1-FT-20XX	30	12.5	M4	6	60	38	2
DRH-ESG1-FT-28XX	36	14	M5	7.5	72	55	3

# **RC8 CONTROLLER ELECTRIC GRIPPER**

---

## **USER'S MANUAL**

First Edition

August 2012

DENSO WAVE INCORPORATED

8P\*\*C

---

The purpose of this manual is to provide accurate information in the handling and operating of the robot. Please feel free to send your comments regarding any errors or omissions you may have found, or any suggestions you may have for generally improving the manual.

In no event will DENSO WAVE INCORPORATED be liable for any direct or indirect damages resulting from the application of the information in this manual.