



Imagine™ I51-2 High-Performance Mobile Audio Speaker System

User's Manual and
Mobile Audio
Reference Handbook

Table of Contents

(Use your mouse and click to advance to various sections below)

Welcome and Introduction	3
Imagine Individual Component Parameters	4
<i>Midbass Speakers (Imagine I5).....</i>	<i>4</i>
<i>Tweeter Speakers (Imagine I1).....</i>	<i>5</i>
Imagine System Specifications	6
Midbass Thiele/Small Parameters (incl. mounting dimensions).....	7
Unpacking/Inventory.....	7
How to Use This Manual	8
Section I - Getting Started – Basic System Installation.....	9
<i>Coaxial / Component Set Conversion.....</i>	<i>11</i>
<i>Installation.....</i>	<i>11</i>
Section II - Moving Forward – Advanced System Installation	14
<i>Lessons Learned.....</i>	<i>14</i>
<i>Lesson One: Off-Axis Response.....</i>	<i>14</i>
<i>Lesson Two: Equalization of Pathlength Differences</i>	<i>14</i>
<i>Lesson Three: The Effect of HRTF, ITD, and IID</i>	<i>16</i>
<i>Lesson Four: Point-Sourcing</i>	<i>17</i>
<i>Lesson Five: Reference.....</i>	<i>18</i>
<i>Advanced Installation of the Imagine Component Systems.....</i>	<i>18</i>
<i>Mounting Baffle Considerations</i>	<i>18</i>
<i>Acoustic Treatment</i>	<i>19</i>
<i>Advanced Installation Conclusions.....</i>	<i>20</i>
Warranty	21
Thank You!	22

Welcome and Introduction

Congratulations on your purchase of high performance Imagine-series mobile audio component loudspeakers, and welcome to the world of Hybrid Audio Technologies, where high-end mobile audio loudspeaker development is our passion! When installed and set-up properly, the Imagine component system you have purchased will make a remarkable improvement in the sound quality of virtually any mobile audio sound system and give years of superior performance.

Thank you for going "on line" to read and download your User's Manual. Our offices are located amongst the evergreens in North Georgia USA, and we happen to like trees. Aside from the obvious aesthetic benefits, trees improve our air, protect our water, save energy, and improve economic sustainability. Additionally, it is expensive to print and distribute thousands of copies of an owner's manual; we'd rather invest our production dollars into an incredible line-up of speaker systems for your listening pleasure. With online resources becoming the main source of information for more and more people, we are pleased that you're here, reading this manual on line, verses having a print copy which might get read once and put back into the gift box, or worse yet, discarded.

With the publication of this user's manual and reference guide, it is our goal to assist the "do it yourself" enthusiast and professional installer alike in getting the highest level of performance out of Imagine 2-way convertible coaxial and component set using straight-forward installation advice and practical application of timeless acoustic principles. As you begin to read this document, you will quickly realize that this is not your typical user's manual. This manual has been written to be more or less a miniature mobile audio reference guide that can be used to better any sound system, and in particular, a system that utilizes the Imagine component speaker systems. It is an introductory primer to the world of high-end mobile audio; we hope this user's manual is not only informative, but motivating. Keep it handy throughout your installation process, and any time you go to improve your audio system with other Hybrid Audio Technologies products. We are confident that if the principles explained in this manual are exercised in your own installation, you will be ecstatic with the sound quality outcome!

We realize that you have a choice in loudspeakers, and are thrilled that you have chosen the Imagine-series. For more information about Hybrid Audio Technologies, our philosophies regarding high-end mobile audio, and for information about our other products, please visit us online at www.hybrid-audio.com.

Thank you, and happy listening!



Scott E. Buwalda
Founder – Hybrid Audio Technologies



Imagine Individual Component Parameters

Your Imagine system contains speaker drivers and a tweeter passive crossover network that were developed and assembled with a significant effort in research and development, materials science engineering, an exhaustive level of sampling and prototyping, real-world testing, and obsessive attention to detail. The specifications and parameters of your Imagine component system is detailed as follows:

Midbass Speakers (Imagine I5)

<p>Frame: Cast ABS plastic.</p>	<p>The basket is a high-quality cast ABS design, which plays a critical role in aligning the voice coil in the magnetic circuit. Additionally, the cast ABS frame allows for better clamping strength versus typical stamped steel frames, and ensures that the voice coil remains centered in the former.</p>
<p>Cone: Pressed paper with water proof treatment</p>	<p>Hybrid Audio Technologies believes that the pressed paper cone is the best marriage of lightness, stiffness, and ability of the cone to damp unwanted cone and edge modes and resonances (read: distortion). All of our designs use pressed paper cones. The paper cone, known for its excellent sonic attributes, is water proof, thanks to a polymer developed exclusive and is proprietary to Hybrid Audio Technologies. The treatment does not change the look and parameters of the driver like old-fashioned "glossy" polymers which added an appreciable amount of moving mass and significantly colored the sound. No, the Imagine cones look like any "normal" paper cone, but in reality are likely the only high-performance water proof paper cone car audio speaker systems on the market. The treatment protects the cone from periodic drips (such as inside a door panel), as well as accidental splashes to the front of the cone.</p>
<p>Phase Plug: Cast ABS plastic.</p>	<p>When using the midbass in component set mode, the tweeter pole piece is replaced with an ABS extended phase plug pole piece. The extended phase plug pole piece is critical for focusing high-frequency information at the center of the cone. This design ensures the speaker's response remains linear into the lower- to mid-treble frequencies.</p>
<p>Surround: Inverted high-loss rubber surround.</p>	<p>The inverted high-loss rubber surround (in concert with the spider, detailed below), helps to provide the compliance and "restorative force" needed for the Imagine drivers to play effectively into the lower midbass, and even upper subbass frequencies (depending on in-car cabin gain and other factors). You'll also know a Hybrid Audio midrange and midbass design by its inverted surround; this design feature allows for the use of a smaller height grille, better clearance with OEM panels, and more flexibility in mounting options.</p>
<p>Spider: Phenolicized fabric and tinned tinsel leads.</p>	<p>The spider is the brownish/yellow corrugated (rippled) fabric that attaches the cone and voice coil. The spider for the Imagine designs was the subject of a considerable amount of our research and development. The spider is a phenolic symmetrically-rolled fabric which provides excellent restorative force during excursion. The spider is vented courteous of the speaker frame; a design element not typically found in this price range of speaker system. The spider venting increases the thermal power handling of the I5 driver. The tinsel leads are connected to real epoxy PCB, not flimsy cardboard.</p>



<p>Voice Coil and Motor System: 25mm Complimentary design.</p>	<p>The voice coil used in the I5 midbass is a 2-layer aluminized copper wire coils on a round former. An “overhung” voice coil was selected to improve sensitivity while still keeping distortion to a minimum.</p>
---	---

Tweeter Speakers (Imagine I1)

<p>Dome: Small diameter impregnated silk textile dome with high-loss rubber suspension.</p>	<p>The I1 has an impregnated fine cloth silk dome diaphragm for a linear, smooth sound, with a high-loss rubber suspension to damp edge modes and resonances. The dome is of extremely low mass and is much less susceptible to mechanical deformation than other designs, and yet yields a smooth response over the extent of its range. At Hybrid Audio Technologies, we feel larger diaphragm tweeters sound heavy and unremarkable, lack detail in the upper treble frequencies, have undesirable polar response, and are difficult to install. Additionally, we find metal dome tweeters to be harsh, brittle, and sound unrealistic. As a small diameter, soft-dome tweeter, the I1 is the antithesis of large diaphragm and metal-dome tweeters, for the effective and convincing reproduction of treble frequencies.</p>
<p>Voice Coil and Motor System: 25mm Complimentary design.</p>	<p>The motor assembly is “conventional dynamic”, with a compact neodymium magnet structure to ensure a small footprint size and shallow depth. A perforated grille protects the dome. The voice coil is ferrofluid cooled and damped, and the tweeter housing consists of extruded plastic with three different mounting options in component set mode, giving the end-user flexibility in not only placement of the I1 but also in physical installation.</p>
<p>Tweeter Passive Crossover: Low-Tolerance Mylar Capacitor</p>	<p>The tweeter’s protection circuit and crossover filter is a very high-quality, low-tolerance Mylar capacitor that has been affixed to the midbass frame. The set ships as a coaxial set, and is ready to install. Should the end-user want to connect the tweeter in component set mode, simply unscrew the tweeter, remotely mount the tweeter, and extend wiring back to the midbass terminals for re-connection to the tweeter output posts. Refer to Page 10 for more details on how to convert from coaxial to component set.</p>



Imagine System Specifications

Frequency Response	60 Hz – 22,000 Hz, \pm 3 dB Typically, in-car response including vehicular “cabin gain”, or the gain expected with midbass installed in the vehicle, will result in an extended midbass and upper subbass response. This is a result of these frequencies being below the lowest resonance in the vehicle (typically around 50-125 Hz in most vehicles, described in more detail on page 17). In more practical terms, install the Imagine midbass into your vehicle and you will see a dramatic improvement in midbass and upper subbass output, much more so than just simply listening to the Imagine in a large room, or worse yet, “free air” (we don’t recommend even trying the Imagine speakers in “free air” without some form of enclosure or infinite baffle for the midbass).
Efficiency at 2.83 volts / 1 meter	93.5 dB
Continuous Power Handling (RMS)	100 watts (musical input)
Peak Power Handling	230 watts (musical input)
Recommended Power Range	20 – 150 watts (musical input)
Nominal Impedance	4 ohms
Thiele/Small Parameter Discussion for Imagine Midbass Speakers	<p>The mechanical and electrical parameters of the Imagine I5 midbass are amenable to a variety of different installations and speaker locations. The high Qms (Q factor of mechanical system) and Qts (Q factor of total system), coupled with the driver’s Fs (resonance frequency) allow it to be used in an “infinite baffle” configuration. In more practical terms, install the Imagine midbass such that the front and back waves don’t “meet” (as detailed in Section I – Getting Started - Basic System Installation), including in a door or kick panel (using only the airspace behind the speaker as a pseudo enclosure), with no need for a real enclosure or “box.” The design goes hand in hand with fool-proof, high-end sound quality with minimal work.</p> <p>For more advanced users, please reference the Thiele/Small Parameters, listed on the following page. Note also the mounting diameter and depth for the I5 midbass.</p>



Midbass Thiele/Small Parameters (incl. mounting dimensions)

please note, the following parameters are for the midbass drivers only

Parameter	5 ¼-inch Midbass
Overall Diameter	6-inch (150 mm)
Mounting Depth	2.75-inch (70 mm)
Mounting Hole	4.85-inch (123 mm)
Recommended Minimum Crossover Frequency	65 Hz
P _{nom} Rated Power Input (No Crossover)	25 watts (AES Standard)
P _{max} Rated Power Input (No Crossover)	50 watts (AES Standard)
P _{max} (With Recommended Minimum Crossover)	175 watts
Frequency Range	55 – 11,000 Hz +/- 4.5 dB
Sensitivity	91 dB at 2.83 V/1meter
M _{ms}	8.9 g
C _{ms}	489 µM/N
BL	5.5 T*m
Voice Coil Diameter	25 mm (1-inch)
Impedance	4 Ω
DC Resistance	3.4 Ω
F _s	76 Hz
Q _{ms}	3.3
Q _{es}	0.468
Q _{ts}	0.424
X _{max}	9 mm (two way)
V _{as}	5.2 L
S _d	8.659 mM ²

Unpacking/Inventory

Carefully unpack the Imagine carton, and verify that the following parts are included in the box (CAUTION: use care to remove the midbass speakers with two hands, and avoid pressing your thumb or fingers against the cone of the midbass¹):

- Two Imagine I5 (5 ¼-inch / 150mm) midbass speakers with integrated tweeter crossover;
- Two Imagine I1 (1" / 25mm) tweeter speakers pre-installed in coaxial mode;
- Two midbass grilles with anodized aluminum Hybrid Audio Technologies nameplates and ABS grille mounting flanges;
- Nine small packages located underneath the midbass drivers, which contain parts for use as a component system:
 - Two tweeter surface-mount cups;
 - Two tweeter flush-mount cups;
 - Two tweeter angle-mount cups;
 - Tweeter and midbass mounting hardware including two silver plain steel tweeter retainer clips (attaches to the back side of the flush-mount tweeter cup to keep the

¹ In addition to being careful unpacking the midbass speakers, NEVER test the speaker's excursion manually with your fingers by pressing the cone down. This can cause a critical misalignment of the voice coil within the former, and may permanently damage your speakers.



- cup solidly installed), machine screws and set screws for the retainer clips, and hardware needed to install the midbass speakers, including high-quality black oxide Philips head screws black anodized screws to mount the midbass speakers; and
- A pair of replacement magnet decals.

Should you be missing parts, please contact your authorized Hybrid Audio Technologies dealer for replacement parts, or contact us directly at info@hybrid-audio.com.

How to Use This Manual

As mentioned in the Welcome and Introduction, this is not your typical car stereo speaker owner's manual. It is a mobile audio reference manual for not only your impending Imagine installation, but also to act as a guide to get the most out of your audio system.

Generally speaking, this manual is divided into two parts. The first part focuses on a typical, basic installation of the Imagine product, and follows in general what you'd expect from a mobile audio component system owner's manual. The second part delves into more advanced topics on optimized speaker placement, "lessons learned" (a topical discussion of real-world applications), use of sound damping products and acoustic absorption materials, and fine tuning. Most users will stop at the conclusion of the first section once the basic installation is complete, and this is perfectly acceptable. But for those with an intrinsic desire to learn more about how to make their mobile audio systems better, we invite you to continue reading through the latter half of the manual as well. Our goal is to not only build the best-performing mobile audio systems in the world, but to also educate consumers and professional installers alike on how to achieve reference-grade audio system playback in the mobile audio environment.



Section I - Getting Started – Basic System Installation

Now that you have unpacked the Imagine box and have verified that all of the parts are included, it is time to evaluate the vehicle for the impending installation. If you feel the least bit uncomfortable about the installation, have the Imagine speakers installed by an authorized Hybrid Audio Technologies dealer. The Imagine speakers are an incredible high-end speaker system, but will only be as good as the installation; a poor installation can negatively affect the performance of the Imagine speakers.

Should you decide that you can handle the installation yourself and feel confident that the end result will be adequate to reap the performance benefits of the Imagine component system, you will need to have certain hand tools available to you for the installation. These include, but may not be limited to:

- Cordless drill/driver with a 1/8" drill bit and a Phillips head and a few assorted Torx screw driver bits with an attachment (a hand-operated screw driver and/or torx driver will also likely work);
- Certain vehicles may require an assortment of Allen wrenches to remove the old speakers and/or panel screws;
- A panel-popping tool (retaining clip removal tool) to remove panels in the vehicle (such as door panels). In a pinch, a large flat-head screwdriver does work, but damage to panels or retaining clips can result;
- A wire cutter and wire stripper;
- Electrical tape; and
- If you plan to use the vehicle's existing speaker wire, you will need to know which wire is positive and which is negative at each proposed speaker location. If you're unsure, we highly recommend the use of [Installation Excellence](#), an on-line resource for wire colors, wire locations, fit guides, and technical support. To access the Installation Excellence site, click your mouse on the blue-highlighted text above.

In a basic system, the Imagine midbass speakers were designed to be installed in the original factory speaker locations, most often in the vehicle's doors (more advanced locations that provide an additional level of performance are discussed in Section II of this manual, if you're interested in learning more). The Imagine midbass drivers are infinite baffle-capable speakers, and must be mounted in a "large enclosure", or as close to it as possible, with unrestricted access to airspace to ensure the speaker's ability to effectively reproduce its wide frequency bandwidth. The reason why the speaker was designed in this way is highly empirical. When a speaker is mounted in a small closed box, it radiates as much energy forward of the cone as it does rearward of the cone. All speaker cones (diaphragms) are a weak sound barrier at best, and the result of the high amount of energy being "pushed" into a small enclosure is the energy transmitting through to the outside of the cone (an additive phenomenon to the incidental wave). Consequently, Hybrid Audio has designed the Imagine midbass to work well without an enclosure, and as such, should not be significantly prone to enclosure back-pressure and sound coloration when placed infinitely baffled. The "infinitely



large” enclosure, such as one might find in a door panel, improves spectral response and power response variation between high and low frequencies.

In a basic system, like the Imagine midbass, the Imagine tweeters were designed to be installed coaxially with the midbass, or as a component system in the original factory tweeter locations, such as those typically found in many newer-generation vehicles, most often at the top of the door, or in the “a-pillar.” The obvious “path of least resistance” is to leave the Imagine speakers in their coaxial mode. If you do decide to use the Imagine set as a component system, and if your vehicle is older, or did not come with factory tweeter locations, you may need to install the tweeters in a bit of a custom fashion. Not to fear though – we have included several different options for easily mounting the tweeters, so you can decide which will work the best for your application. Since the tweeters are a sealed-back design, they can be placed anywhere without having to provide airspace or any type of enclosure. Hybrid Audio Technologies highly recommends that the tweeter placement be the subject of your own experimentation. This can be accomplished by leaving some excess wire length for the tweeter, and experimenting with different potential mounting locations by temporarily attaching the tweeter using double stick tape, Velcro[®], etc.

An important learning note! Hybrid Audio Technologies designed the Imagine-series to be used predominantly as a coaxial, as we can effectively mitigate anticipated environmental conditions and reduce the number of variables in this type of installation. When used as a coaxial, the relative amplitudes (volumes) of the midbass and tweeter are equalized to each other and the speaker will perform as intended. There is much less amplitude control of the tweeter amplitude with respect to the midbass amplitude when the set is converted into component set mode. This is due to simple physics. If the midbass drivers are placed low in the door, for example, and the tweeter is placed high in the dashboard, sail panels, or a-pillars, there WILL be a notable amplitude difference between the two speakers. This is because the midbass are installed further from you, and are likely aimed into your leg, carpeting, and other soft furnishings in the vehicle, while the tweeter is located likely closer to you, likely aimed more “ox-axis”, and is near hard, reflective surfaces, such as window glass, hard plastic interior panels, and etc. In many cases, converting to component set will cause the tweeter to be notably louder than the midbass. This is not a speaker malfunction; it is a simple acoustical phenomenon playing out in your vehicle. Hybrid Audio Technologies usually recommends that the Imagine sets be left as a coaxial, but encourage the end-user to test the Imagine systems in both formats to evaluate what suits the end-user’s listening habits best. Finally, just because there is a factory tweeter pod location in the dashboard, a-pillars, or sail panels in your vehicle doesn’t mean you have to use it! Because our ears are on the left and right sides of the human head, human hearing is much less susceptible to hearing height cues as it is hearing width and depth cues (please reference Lesson 3 and Lesson 4 later in this manual). Please don’t be fooled into thinking that the tweeters MUST be placed high in order to establish a good stage height! Alas, as the end-user, it is up to you to take the time and test the set to see what orientation is to your liking, and certainly, as students of acoustics, we at Hybrid Audio Technologies encourage that learning exercise.



Coaxial / Component Set Conversion

At this juncture, you must decide if you want to install the Imagine set as a coaxial, or as a component system. If you opt to continue on as a coaxial, you can disregard this section. If installing as a component system, read on.

Here are a few very simple steps to convert your coaxial into a component set:

1. Remove both midbass' from the Imagine carton and flip them upside down on a clean, non-abrasive surface such as a kitchen table.
2. Peel the Imagine decals off of both of the midbass magnets. You will now see a small screw in the dead center of the magnet. This screw is holding the tweeter and the tweeter pole piece (the "platform" the tweeter is attached to) in place.
3. Disconnect the tweeter's wires from the midbass' terminals. Note that red is positive and black is negative.
4. Put the midbass in your hand and softly cup the tweeter in the palm of your hand. Use a 3mm hex wrench (alan-head wrench) to remove the screw and allow the tweeter pole piece to drop out from the front of the midbass into your hand. Pull the speaker wire through the midbass' magnet. DO NOT DISCARD THE SCREW!
5. Locate the extended phase plug pole piece in the kit (looks like a bullet), and insert the bullet into the magnetic gap the same way the tweeter pole piece used to be inserted. Secure the extended phase plug pole piece bullet with the screw you just removed. Tighten securely, but don't over-tighten. Note, the screw is the perfect length to snug the pole piece to the former. DO NOT shorten the screw or use a different screw! The last several turns of the hex key actually "cut" threads into the phase plug, ensuring that it does not come loose over time. Keep turning the screw until the phase plug is secure. Please read here for more details: <http://hybrid-audio.com/Technical%20Bulletin%20-%20Imagine%20Phase%20Plug%20Screw.pdf>.
6. Locate the magnet decal in the Imagine carton and replace the decal to the magnet of the midbass. The decal doesn't need to be installed if you want to skip this step.
7. Extend some speaker wire length (not included) between your tweeter location back to the midbass, and re-connect (red to positive and black to negative).

Installation

Once you have determined the mounting locations for the Imagine separates, and have evaluated the circumstances by which the Imagine speakers will need to be installed, it is time to dismantle the vehicle to access the old speakers. Most dashboard-mounted speakers are easily accessed by removing their grilles, which are usually attached to the dashboard with screws or retaining clips. A-pillars are usually accessed by pulling firmly at a right angle to the panel. Door speakers are usually easy to access as well, either from the front by prying off the OEM grille, or by physically removing the entire door panel. In all cases, it may be prudent to reference your vehicle's factory service manual. If you don't have a factory service manual, you can go to the [Installation Excellence](#) website for downloadable resources with



respect to not only wiring but disassembly of your vehicle, and the procedures to access your OEM speakers.

With the OEM speakers removed, we **HIGHLY** recommend the use of a self-adhesive damping product, such as brand names Dynamat[®], B-Quiet[®], and others. The reason for the use of damping material is to quiet buzzes and rattles that will be exposed by the high-performance Imagine midbass speakers, but more importantly to seal up door accesses and cavities, thereby creating a pseudo "enclosure" for the Imagine midbass. If the midbass are installed immediately adjacent to a large access hole or opening in the door panel, there will be an acoustic "short circuit" (as described later in "Frequency Response") where the front and back waves of the speaker meet, and cancellation will occur, seriously effecting midbass output. The use of a good damping product is the single-biggest installation-related improvement you can do to enhance the performance of your Imagine audio system. And since the Imagine midbass require an "infinite baffle", it is intuitive to seal up the mounting area as best as possible, such as in the door, allowing the speaker to "see" a large enclosure in the door cavity, kick panel, dashboard, or wherever you decide to mount the Imagine midbass.

If you plan to use the OEM speaker wiring, you will likely need to cut off the OEM speaker plug, and strip back approximately 3/8" (10mm) of insulation to expose the bare wire. It is recommended that you then install slide-style terminals on the wire, for easy connection to the Imagine midbass.

In a basic installation, the Imagine midbass were designed to install directly into the factory-supplied speaker baffles or speaker openings. The speaker should fit snug to the baffle without air gaps; do not force the speaker into a baffle that is too small, as this will damage the speakers. If the factory-supplied mounting baffle is too small, refer to Section II for advice on how to build custom baffles. When tightening your speakers to the baffle, alternate the tightening of the screws, just as if you were changing a tire on your vehicle, by alternating in a pattern around the speaker until all screws are hand-tight. **DO NOT INSTALL THE SPEAKERS WITH A DRILL OR DRILL-DRIVER**, as the drill-drive will put considerably more torque on the speaker basket than what is required, and can easily damage the frame of the speaker.

In the event a component set mounting topology is chosen, the same procedure can be followed for the tweeter installation observing the precautions mentioned in the midbass installation, above. Once a suitable location is found for the tweeters, mounting options can be evaluated. The Imagine kit comes standard with three tweeter mounting options, including a swivel flush-mount cup, a surface-mount cup, and an angle-mount cup. The tweeter fits first into the surface-mount cup, and then can be installed as one unit into the flush-mount cup. Conversely, the surface-mount cup can be attached to the angle cup as well. In all cases, the tweeter is fitted into the surface-mount cup first, and in then either installed as-is, or is further encased in the flush-mount cup, or is attached to the angle-mount cup. Decide which mounting strategy works the best for your installation, and permanently mount the tweeters. Route the wiring from the underside of the tweeter to an accessible location and connect to the tweeter connections (small diameter slide terminals) on the midbass frame.



Once all four speakers are installed, you will need to do a brief listening test with CD-quality music that you are intimately familiar with to determine if the tweeter seems to be linear in amplitude with the midbass, or seems to be too muted. If the tweeter seems too muted, or if you prefer a louder tweeter sound, simply reverse the black and red wires on the tweeter terminals located on the frame of the midbass. You will be changing the polarity of the tweeter, and will be increasing the loudness of frequencies between approximately 6,000 – 10,000 Hz by doing this.

Once all four speakers have been installed and the level set as per the above, the sound damping cropped so as to allow for the re-installation of door panels and/or interior panels, and all wiring neatly wire-tied away from heat and noise sources, or from abrasion and areas where the wires may be accidentally sliced or cut, the vehicle can be re-assembled. Sit back and enjoy the music.

This is the end of Section I: Basic Installation. If you're happy with the end product, stop reading here. If you want to learn more about advanced techniques for achieving great mobile audio sound quality, flip the page!



Section II - Moving Forward – Advanced System Installation

The previous section detailed a typical, basic installation of the Imagine product. In this section, Hybrid Audio Technologies has prepared a more advanced topical discussion of Imagine I51-2 installation techniques, concepts, and principals, where a little bit of additional installation work can net immense gains in overall sound quality.

There are certainly many things you can do to improve your mobile audio system, such as addition of amplification, a dedicated subwoofer system, higher-gauge speaker wire, and higher-end passive crossovers, and active crossovers. All of these things require an additional amount of monetary investment into your audio system, and may not net the immediate gains that other, more elementary installation items can net.

The following discussion is pertinent to easy and cost-effective enhancements you can do for your audio system, particularly as it relates to the installation of Imagine component speakers. In any mobile audio system, the weakest link will always be the speaker systems, followed closely by installation techniques (sometimes its vice-versa). Since the Imagine component system you have purchased has solved the first issue, where speakers are the weakest link in your audio system, the second issue, that being installation techniques, can see a significant improvement as well by understanding and incorporating some or all of the techniques in the following sections.

Lessons Learned

We like to call this our “Lessons Learned” section, where we expose some critical lessons that we have learned through thousand upon thousands of hours of trial and error:

Lesson One: Off-Axis Response

When a speaker system like the Imagine I51-2 is placed in an automotive environment, we hear the direct (shortest path) and reflected (longer path) sounds, such as resonances and reverberations. The two sounds are processed by the brain as one sound, and this influences our perception of height, width, and depth of soundstage, as well as rearward ambience. For this reason, the off-axis radiation pattern of any speaker in a vehicular environment has a significant influence on how natural the music sounds.

The lesson to learn here is that most mobile audio sound systems benefit greatly from having the front stage speakers at least partially “off-axis.” Off-axis means that the speakers are not pointing at you, but rather at some angle less than 90 degrees away from you.

Lesson Two: Equalization of Pathlength Differences

Quite possibly the most important functional consideration that a do-it-yourself enthusiast or professional installer should give to the Imagine speaker placement is to optimize, as best as possible, pathlength differences (PLD’s) in the vehicle. PLD’s are defined mathematically as



follows (this example assumes a right-hand driven vehicle---PLD's are always a positive number):

$$X - Y = Z$$

Where:

X = distance of the center of the left speaker from your left ear.

Y = distance of the center of the right speaker from your right ear.

Z = pathlength difference.

Applying this formula, assume that the distance of the left speaker from your left ear is 140cm, and the distance of the right speaker from your right ear is 100cm, the pathlength difference is 40cm.

Good stereo imaging is completely dependent on arrival times of the fundamental vocal frequencies. Differences as little as 10 microseconds can be detected by the brain. A PLD of 30 centimeters equates to the sound from the nearest channel arriving about 0.9 milliseconds earlier than the furthest channel. It is Hybrid Audio's opinion that the end-user should try to keep PLD's to less than 30 centimeters in a vehicle which is intended to have good imaging and staging character **from both seated positions**.

The best way to go about evaluating certain locations in your vehicle is, in general, to look for the potential locations as far forward and away from you as possible, but still with a general "line of sight" to the speakers (particularly the speaker on the far side of the vehicle). An easy way to test various potential locations is to hold a tape measure or other measurement device from the potential speaker mounting locations, and measure those locations with respect to your ears.

Reference Figure 2, below. In this scenario, three potential locations for the mounting of the I5 midbass driver are shown:

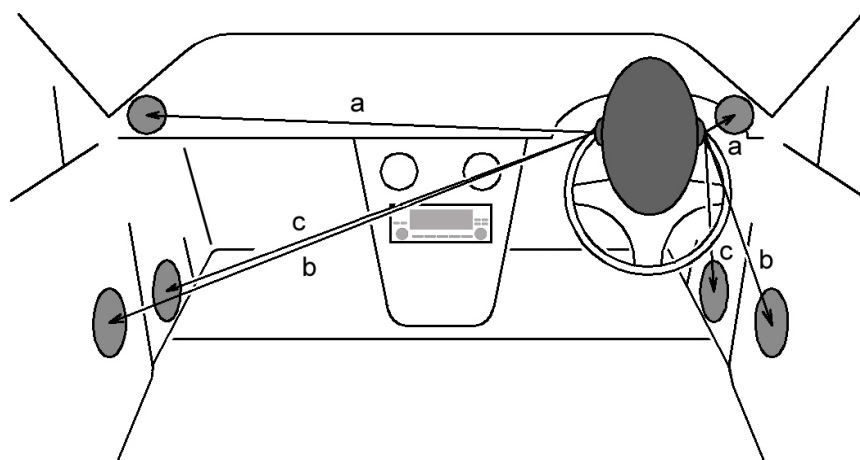

Figure 1: Potential Locations for Mounting the Imagine Midbass Speakers



In scenario "a", we show the installation of the I5 in the dashboard, high in a door panel, or a-pillars. As you can see from the diagram, the PLD's between the left and right speakers are large, due to the proximity of the listener to the near-side speaker. While the mounting of primary drivers in the dashboard or a-pillars has become increasingly popular, this configuration will undoubtedly require both time and intensity domain equalization in most vehicles to ensure a good, focused center image, properly located in the center of the vehicle for **one seated position**. There are, however, some rare exceptions, and you may actually find that the dashboard locations provide the best equalized PLD of the available mounting locations; this is very rare though – in our experience, less than one percent of vehicles on the market today have optimized dashboard speaker locations for the midbass drivers.

In scenario "b", a typical door installation location is shown, and in many vehicles represents a good improvement in PLD's from the dashboard, high in the door panel, and a-pillar location identified in scenario "a." The door speaker installation scenario is the one detailed in the basic installation section at the beginning of this manual, and in most vehicles represents a satisfactory location to mount speakers; not ideal but satisfactory. The door speaker installation scenario will likely also require some amount of time and intensity equalization to ensure a centered image in most vehicles; this can be as simple as adjusting the balance control on your source unit, to more advanced ways of digital time and intensity manipulation.

The third and final potential mounting location as shown in this diagram (scenario "c") represents a kick panel installation, where the midbass are placed far forward in the A-frame cavity of the kick panels, present in most vehicles. The kick panels are the small panel next to the throttle and brake pedals, down by your feet. While it is not immediately obvious looking at a two-dimensional drawing, in many cases the kick panel location affords the best equalization of pathlength differences for most vehicles. And the reason why this is a good choice for most vehicles is defined in the second full paragraph of Lesson Three, below.

The lesson to be learned here is that by taking a few moments to evaluate the potential mounting locations in your vehicle, in a very short period of time, you will be able to find the best location for your I5 midbass by determining the location with the smallest PLD.

Lesson Three: The Effect of HRTF, ITD, and IID

Head-related transfer function (HRTF), interaural intensity differences (IID), and interaural time delay (ITD) all play a key role in the optimum placement location for the Imagine component speakers. A sound wave approaching the eardrum from your chosen speaker location is shaped by interactions with the size and shape of your head, torso, and outer ear, resulting in the HRTF. More specifically, the HRTF is the ratio between the sound pressures of the wave at the eardrum, as compared to the sound pressure that would exist at the center of the head if the head were removed. In general, the sound arriving at the ear further from the source is attenuated and delayed relative to the sound arriving at the ear closer to the source. This generates an interaural intensity difference (IID) and an interaural time delay (ITD). As a sound approaches the head, the ratio of distances from the speaker location to the near and far ears increases, and the effects of head-shadowing are amplified, causing the IID to increase. The spectral shaping caused by the head and the shape of the outer ear may also



change. The ITD, which results from the absolute difference in path length from the source to the ears, remains approximately constant as distance decreases. From this we learn:

- ITD is the dominant factor for frequencies below about 500 Hz;
- A combination of ITD and IID are dominant for frequencies between approximately 500 Hz and 2,000 Hz; and
- IID, in concert with HRTF, are dominant above about 2,000 Hz.

These are generalizations, and are subject to the size and shape of one's head and torso, and size and shape of the outer ear (the folds and ridges of the ear), but in general, the above is a good guideline for establishing ITD, IID and HRTF thresholds for the human auditory system. Because the I5 midbass' ability to play into the sub-200 Hz range, an effect clearly dominated by ITD, up to and including frequencies exceeding 6,000 Hz, an effect clearly dominated by IID and HRTF, placement of this driver is extremely important. The driver should be placed as far forward as possible in the vehicle to optimize ITD. Lateral (forward to back) placement is much more important than horizontal placement (up and down). This is because of the brain's ability to process sounds such as spectral envelope cues, and use a phenomenon known as the "precedence effect"; the brain can be easily "fooled" into thinking a sound stage is high with kick panel or floor-mounted speakers (a word to the wise: the best place to put a set of speakers is not always "up high", as most vehicles do not offer an amicable location in the dashboard or a-pillars for good image placement for both seated passengers, especially in the critical frequencies sub-500 Hz). In addition to the time equalized placement of the drivers, the end-user must also consider that above approximately 2,000 Hz, intensity plays a key role in good sound staging and imaging. Therefore, the Imagine midbass' should be placed in an area where intensity differences can be equalized, either mechanically or electronically, to ensure good imaging and sound staging.

The lesson to be learned is that, like Lesson Two, the Imagine midbass should be placed as far forward from your listening position as possible, and every effort should be made to optimize time and intensity domain characteristics of the installation.

Lesson Four: Point-Sourcing

The term "point-sourcing" is often used to describe the technique of having a single pair of speakers in an installation cover the majority of the critical middle band frequencies. In many installation scenarios, the Imagine midbass could be considered a point-source speaker driver, because it has the ability to reproduce six octaves of tones. Point-sourcing, if done correctly, can lend itself to a variety of valuable attributes, including precise image definition and stable sound staging character. By applying Lessons 1-3 above, the Imagine I5 can be used as a point-source midbass driver to achieve excellent staging and imaging results.

The lesson to be learned here is that the I5, given its wide-bandwidth design, can faithfully reproduce as much as six octaves of tones, and would make a valuable addition to any sound system as a point-source driver for the spectrum comprising vocal imaging cues.



Lesson Five: Reference

One of the most important things to do before completing your Imagine installation is to get a reference for your future listening tests. To really know what a snare drum sounds like, you must go and listen to one, in person, live and un-amplified. There is no substitute for the visceral impact and emotion of live music. Nothing else in life can touch your soul the way music does. Whether it's a 200-member orchestra, or a four-piece fusion band, nothing compares to the phenomenon of live music.

Take this as Hybrid Audio's official request: become a student of music and your mobile audio sound system will be better for it. We want nothing more than to know there are great sounding audio systems around the world using our products, and you'd make us all very proud if you became a student of music and learned its beauty and passion.

Advanced Installation of the Imagine Component Systems

Mounting Baffle Considerations

Now that we have revealed five of our most important "Lessons Learned", we can now apply these lessons to the Imagine installation. The first important matter is the physical installation of your Imagine midbass, and more specifically with respect to improving the Imagine midbass' mounting baffles. Most vehicles' factory mounting locations for speakers are less than ideal. In most cases, the OEM speaker mounting flanges are likely nothing more than flimsy extruded plastic, and provide no sonic benefit to your Imagine installation. The Imagine drivers are long-throw midbass, and the plastic mounting baffles that come from the factory in virtually every vehicle will lead to buzzes, rattles, vibrations, and resonances, all of which negatively effect the Imagine installation. In other vehicles, you may have attached the Imagine midbass' directly to the door metal (hopefully with a layer or two of self-adhesive sound damping in between), but this is still not entirely ideal. In whatever scenario you have installed your Imagine midbass, there are certain "tricks" and techniques that may be applied to get the most out of your Imagine component set, specifically the midbass installation, as follows:

- **Mounting the baffle, sound damping, and "decoupling"**: the mounting baffle or mounting location should either be secured extremely well to the vehicle's body, or completely isolated from the vehicle's chassis. The reasoning is that the speaker baffle panel will vibrate and will radiate sound. Even small vibrations can result in the baffle itself radiating more sound than the actual speaker at certain frequencies. The mounting baffle or mounting location should be damped with a layer of typical sound damping to reduce the Q of the baffle and lower its vibration resonance frequency below the range of the driver's frequency response. In many cases, using thicker baffle panel in concert with self-adhesive sound damping can also be advantageous, provided the rearward wave of the speaker has no obstructions created by the baffle itself. Finally, if possible, the speaker should be mechanically decoupled from the baffle. This can be something as simple as a layer of self-adhesive foam tape, to more exotic examples of decoupling, including rubberized rings or multiple-layer septum shielding.



- **Building solid mounting baffles:** in many cases, it is advisable to mount your Imagine midbass' in high-stiffness wood or high-density fiberglass (or wood treated with fiberglass resin). Hybrid Audio Technologies recommends the use of a solid hardwood, such as birch or oak, namely because these woods are stiff and help to dissipate resonance, and screws can be inserted and removed multiple times without stripping. Avoid Medium Density Fiberboard (MDF), particularly in wet environments like the door, as the MDF will act like a sponge with humidity and moisture, and not only that, the MDF is a dense, but not stiff type of wood, and the results may not be particularly noticeable if you use MDF. Once your baffle is built, it must be covered in one or two layers of a good-quality, brand name self-adhesive damping product; a solid wood mounting baffle with sound damping treatment will augment the Imagine installation by eliminating resonances.
- **Mounting baffle dimensions:** While building baffles is important, it is notable that mounting baffle size is equally important. All mounting baffles should be kept as small as possible with respect to the size of the speaker. The purpose of using a small baffle is to avoid the potential for low amplitude diffracted sound waves becoming summed with the incidental waves. A narrower baffle also becomes increasingly important as frequencies range into the Imagine midbass' upper bandwidth, where the power response is more uniform and incident and reflected waves are indistinguishable. In practical terms, keep baffle dimensions small with respect to the size of the Imagine midbass, chamfer or round sharp edges (including, in particular, the mounting hole's rear inner edge), flush-mount the speaker whenever possible, and use shallow, surface-mounted hardware. Also, remove all unnecessary protrusions from the baffle surface.

Acoustic Treatment

A considerable benefit can be made to any mobile audio system with the select placement of acoustic treatments. The purpose of using acoustic treatments is to reduce the amount of reflected energy in the hostile automotive environment, and hear more of the direct sound being emanated from the speaker. It is akin to the signal to noise (S/N) ratio in a piece of electronics, where the signal could be considered the direct energy coming from the speaker, and the noise could be considered the reflected waves off of nearby surfaces, such as windows, hard center consoles and door panels, windscreens, and etc. A word of warning though: there is a fine line between too little and too much acoustic treatment; just as some vehicles can benefit from some selectively applied treatments, there is a point where the vehicle can begin to approach "semi-anechoic" conditions, and lose its liveliness, which is not ideal. Reflections are all around us, and are a part of our day-to-day lives. It is our opinion that some lateral reflection is a good thing; it helps to establish stage boundaries, and gives the recoded playback and more visceral and "believable" sound.

The first principle to understand is that below 200 Hz, acoustic treatments are rendered virtually useless. It is Hybrid Audio's assertion that only those frequencies above 200 Hz benefit from the use of treatments, given that a 200 Hz waveform is about 1.7 m long; 1.7 meters is less than or equal to most vehicle widths. This is also the frequency where we



believe *pure tones* in the vehicle are going to be difficult, if not impossible to localize. Finally, most vehicles exhibit a Schroeder Frequency (F_s) between 50 at 125 Hz; the F_s (or cabin-gain frequency) is vehicle dependent, and is the frequency at which resonances become so tightly packed in frequency and space that the acoustical properties of the vehicle behave quite uniformly.²

Acoustic treatment can be very effective above 200 Hz, depending mostly on the polar radiation pattern of the speaker. In the case of the Imagine midbass, the polar radiation pattern is quite large at lower frequencies, with a narrowing of the radiation pattern ("beaming") at frequencies into the treble bandwidth.

Should the Imagine midbass be placed in the kick panel locations, one may find that a notable improvement can be made by adding acoustical treatments, such as open-cell foam, into the underside of the dashboard. Likewise, should the midbass, or in fact the I1 tweeter be placed up high on a-pillars, or in the dashboard, where comb filtering (reflective summation and cancellation off of a hard surface, such as a windscreen) may become an issue, a dashboard "mat" or other soft furnishing may be a noticeable improvement. It will require trial and error to get it right, but the learning is in the experimentation!

Advanced Installation Conclusions

Sadly, there are no rules in mobile audio, only several hypothesis and theorems that seem to work for *most* vehicles. Your vehicle may be different, and defy everything we know, and everything written in this manual. You may find that getting that rich, detailed sound that you crave may require some experimentation and a lot of work to make it right. Or you might be fortunate to have a vehicle that sounds excellent with minimal work. Have patience and work through the issues; the result will be a rewarding musical experience in your vehicle! Just remember, it is critical to get a reference, as detailed in Lesson 5. Go out and become a student of music and audio, learn, and improve your audio system one step at a time. The journey is exciting and rewarding!

What we have included above is only a very brief primer to the world of high-end mobile audio systems. We invite you to read more by going to our [Downloads](#) web page.

² As an aside, one significant benefit of car audio sound systems is that frequencies below the lowest room resonance increase at a theoretical 12 dB/octave...it's no wonder car audio systems have such great bass!



Warranty

Hybrid Audio Technologies extends a limited one year warranty to the original purchaser, certifying that this product will be free from defects in materials and workmanship under normal and proper use for one year from the date of purchase.

Hybrid Audio Technologies' responsibility under this warranty is limited to replacing or repairing, at Hybrid Audio Technologies' option, products or parts determined by Hybrid Audio Technologies to be defective either in materials, or workmanship. To attain warranty service, the customer must deliver the product or the defective part(s), appropriately packed with proof of purchase date, to an authorized Hybrid Audio Technologies dealer. In the event that a direct return from a consumer is required, the consumer must obtain from Hybrid Audio Technologies a return authorization number, and ship the defective product directly to Hybrid Audio Technologies. All shipping expenses are the customer's responsibility. If the product has been updated or superseded, a replacement will be made with a current model of the same quality and function. Warranty of the replacement parts is limited to 90 days or the unexpired portion of the warranty period of the product on which the parts are being used, whichever is longer.

This warranty does not cover any defects or costs caused by: (1) modification, alteration, repair or service of this product by any persons or company other than Hybrid Audio Technologies; (2) physical abuse to, overload of, or misuse of, the product or operation thereof in a manner inconsistent with the use indicated in the instructions; (3) any use of the product other than that for which it was intended; or (4) shipment of the product to Hybrid Audio Technologies for service. This warranty does not cover labor costs.

Hybrid Audio Technologies is not liable for any special incidental or consequential damages, including, but not limited to, personal injury, property damage, damage to or loss of equipment, lost of profits or revenue, costs of renting or buying replacements and/or any other additional expenses, even if Hybrid Audio Technologies has been informed of the prospect of such damages. Any express warranty not provided herein, and any remedy which other than the warranty contained herein might arise by inference or operation of law, is hereby excluded and disclaimed including the implied warranties of merchantability and of the fitness for a particular purpose.



Thank You!

Hybrid Audio Technologies is delighted that you have chosen an Imagine component system for your high-end mobile audio sound system. We are convinced that a great product offering, backed up with unsurpassed customer service and technical support will advance the Hybrid Audio Technologies namesake in the coming years. We are pleased that you have joined us in our “new generation of in-car audio.”

If there is anything we can do to help you get the most out of your Imagine installation, please do not hesitate to contact us at info@hybrid-audio.com, or by visiting us on line at the www.hybrid-audio.com!

