

VALVE-TRONIC Plus™

User Manual Revision 03



Manual #: 010

Rev No 03

Date: 29 March 2013

COPYRIGHT

No part of this publication may be reproduced, transmitted, transcribed, stored in a retrieval system, or translated into any language or computer language, in any form or by any means, electronic, mechanical, magnetic, optical, chemical, manual, or otherwise, without prior written permission of United Process Controls Inc.

DISCLAIMER:

The *Valve-Tronic Plus™* is to be used by the industrial operator under his/her direction. United Process Controls Inc. is not responsible or liable for any product, process, damage or injury incurred while using the *Valve-Tronic Plus™*. United Process Controls Inc. makes no representations or warranties with respect to the contents hereof and specifically disclaim any implied warranties or merchantability or fitness for any particular purpose.

For assistance please contact:

United Process Controls Inc.

TEL: +1-414-462-8200 • FAX: +1-414-462-7022

Toll free North America: +1-800-438-3347

waukee.support@group-upc.com

www.group-upc.com

WARNING

Thank you for purchasing control equipment from United Process Controls Inc. We want your new control equipment to operate safely. Anyone who uses this equipment should read this publication (and any other relevant publications) before installing or operating the equipment.

To minimize the risk of potential safety problems, you should follow all applicable local and national codes that regulate the installation and operation of your equipment. These codes vary from area to area and usually change with time. It is your responsibility to determine which codes should be followed, and to verify that the equipment, installation, and operation are in compliance with the latest version of these codes.

At a minimum, you should follow all applicable sections of the National Fire Code, National Electrical Code, and codes of the National Electrical Manufacturer's Association (NEMA). There may be local regulatory or government offices that can also help determine which codes and standards are necessary for safe installation and operation.

Equipment damage or serious injury to personnel can result from failure to follow all applicable codes and standards. We do not guarantee the products described in this publication are suitable for your particular application, nor do we assume any responsibility for you product design, installation, or operation.

If you have any questions concerning the installation or operation of this equipment, or if you need additional information, please call us at 414-462-8200 (Toll free North America: +1-800-438-3347)



WARNING: Read this manual thoroughly before using Control Valve.



WARNING: This unit contains ESD (Electrostatic Discharge) sensitive parts and assemblies. Static control precautions are required when installing, testing, servicing or repairing this assembly. Component damage may result if ESD control procedures are not followed. If you are not familiar with static control procedures refer to an applicable ESD protection handbook.



WARNING: The Valve on this unit is not designed for positive shut-off. Valves may leak gas into equipment and cause asphyxiation or poisoning to personnel within confined space. If positive shut-off is desired install a mechanical valve prior to the Flo-Meter and verify that it is shut-off prior to servicing equipment attached to the unit.



WARNING: Flo-Meter must be earth grounded. Ungrounded Flo-Meters may become a source of Ignition.

TABLE OF CONTENTS

WARNING.....3

1. MANUAL OVERVIEW6

2. CONTROL VALVE INTRODUCTION7

3. SPECIFICATIONS.....8

4. INSTALLATION AND WIRING.....9

 4.1 Flo-Meter Installation 9

 4.2 Valve-Tronic Plus Control Valve Installation 10

 4.3 Optional Flow Compensating Pressure/Temperature Sensor Installation 10

 4.4 Wiring Guidelines..... 11

 4.5 Wiring Terminals..... 12

 4.6 Power Wiring Diagram 13

 4.7 Control Wiring Diagram..... 13

5. CONNECTING TO A LEGACY WAUKEE-TRONIC14

6. POSITIVE SHUT-OFF15

 6.1 Solenoid Valve Sizing and Location..... 15

 6.2 Controlling the Solenoid Valve..... 15

7. KEYPAD OPERATION AND DISPLAY OVERVIEW16

 7.1 Keypad 16

 7.2 LCD Display 16

 7.3 Function Keys..... 17

 7.4 Displaying the status of the Valve-Tronic Plus..... 18

 7.5 Alarm Status of the Valve-Tronic Plus..... 18

 7.6 Access Levels of the Valve-Tronic Plus 19

 7.7 Programming the Valve-Tronic Plus 20

8. CONTROL VALVE PARAMETERS21

9. DETAILED PARAMETER LISTINGS24

10. WEB INTERFACE MANAGEMENT & CONFIGURATION33

 10.1 System Requirements..... 33

 10.2 Establish Communication Link to PC..... 33

 10.3 Exploring the Interface..... 35

11. MODBUS COMMUNICATIONS40

 11.1 MODBUS TCP 40

12. CONTROL VALVE MEMORY ADDRESSES	41
12.1 Parameter Memory Addresses.....	41
12.2 Status Addresses.....	42
12.3 Status Monitor 1 Error Codes.....	42
12.4 Memory Location and Data Types.....	42
13. TROUBLESHOOTING	45
13.1 Error Messages	45
14. APPENDIX “A” - DRAWINGS	47

1. MANUAL OVERVIEW

The Purpose of this Manual

Thank you for purchasing a *Valve-Tronic Plus* flow control valve. This manual shows you how to install, wire and maintain Waukee's Valve-Tronic. It also helps you understand how to interface it to other devices in a control system. This manual contains important information and should be read and understood by all individuals who install, use or service this equipment.

Supplemental Manuals

The Installation and Operation of Waukee Flo-Meters Manual contain technical information as well as precautions about Waukee Flo-Meters.

Technical Support

We strive to make our manuals the best in the industry. We rely on your feedback to let us know if we are reaching our goal. If you cannot find the solution to your particular application, or, if for any reason you need technical assistance, please call us at:

+1-414-462-8200 Toll free North America: +1-800-438-3347

Our technical support group will work with you to answer your questions. They are available Monday through Friday from 8:00 A.M. to 4:30 P.M. Central Standard Time. We also encourage you to visit our web site where you can find technical and non-technical information about our products and company.

<http://www.group-upc.com>

If you have a comment, question or suggestion about any of our products, services, or manuals, please e-mail or contact us by phone.

Conventions Used



When you see the “exclamation point” icon in the left-hand margin, the paragraph to its immediate right will be a warning. This information could prevent injury, loss of property, or even death in extreme cases. Any warning in this manual should be regarded as critical information that should be read in its entirety. The word **WARNING** or **CAUTION** in boldface will mark the beginning of the text.



When you see the “notepad” icon in the left-hand margin, the paragraph to its immediate right will be a special note.

2. CONTROL VALVE INTRODUCTION

Purpose of Control Valve

Control valves are used to vary the flow of fluid through a Flo-Meter. The Control Valve is microprocessor based and compares a flow control signal (4-20 mA represents zero to full scale flow) to the actual flow signal produced by the Flo-Tronic Flow Sensor on the Flo-Meter. If there is no difference between the control signal and the actual flow signal, the system is “satisfied” and the motor does not drive. If the flow signal is different from the control signal, the system will tell the valve to drive open or closed until the flow signal matches the control signal. The *Valve-Tronic Plus* is programmed to automatically “ramp” to a set point smoothly to limit under and over shoot.

The unit is factory tuned to each flow specification to provide smooth control action. The unit’s response and control is limited by the response of the customer-supplied controller, inlet pressure, flow range, gas type and downstream restrictions. If necessary, the *Valve-Tronic Plus* may be “field tuned” for a variety of applications.

The *Valve-Tronic Plus* control valve offers the following features:

- Control and Flo-Tronic Feedback diagnostic Indicators
- P.I.D. Control
- Error codes to aid in troubleshooting
- Shut off contacts to close the valve by opening a remote switch or contact
- Three Alarm contacts that can be programmed for various alarm types
- Built in set-point generator which allows the unit to function from an internal set-point

Model Explanation

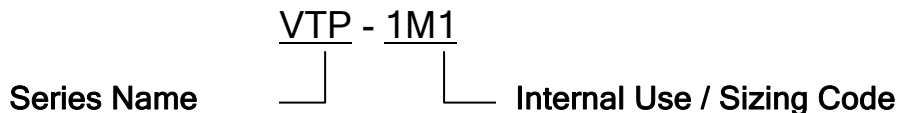

Nameplate Information

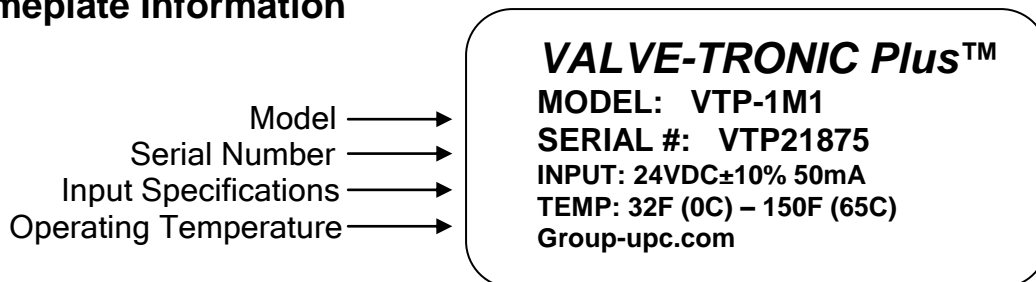

4. INSTALLATION AND WIRING

4.1 Flo-Meter Installation

The Installation and Operation of Waukee Flo-Meters manual contains instructions on the proper installation of the Flo-Meter. Read all CAUTIONS and WARNINGS before proceeding.

The *Valve-Tronic Plus* Flo-Meter is shipped as a complete unit. Before installing the Flo-Meter, carefully remove the Flo-Tronic Sensor, to achieve this lay the unit on its side on a work bench or table. Hold the Flo-Tronic unit with one hand while unscrewing the union nut counterclockwise with the other hand to loosen it.



CAUTION: Once the Flo-Tronic is loose from the Flo-Meter make sure to pull the Flo-Tronic Transducer from the Flo-Meter straight back off the float rod assembly. Moving the Flo-Tronic Transducer to one side or another during removal may result in damage to the float rod assembly.

Remove the Float Rod Assembly and store it in a safe location until Flo-Meter body is installed and mounted. Once the Flo-Meter is installed, remove the red tape from the float rod and insert the float rod assembly into the Flo-Meter body. Fill the Sight Glass Tube with Waukee Flo-Meter Oil so that the level of oil is approximately one (1) inch from the top. Then carefully install the Waukee-Tronic on to the Flo-Meter.



Do not put oil in the sight glass tube of meters used for oxygen or methanol service. Oxygen Flo-Meters should be run dry, or with distilled water. Flo-Meters for Methanol service will automatically fill the sight glass tube with Methanol when in service.



WARNING: Do not fill the sight glass tube with Flo-Meter oil on meters used for oxygen service. Use of oil may cause fire or explosion. Serious personal injury may result from fire or explosion.



If the *Valve-Tronic Plus* is shipped separately to be installed onto an existing Flo-Meter, please refer to the following page.

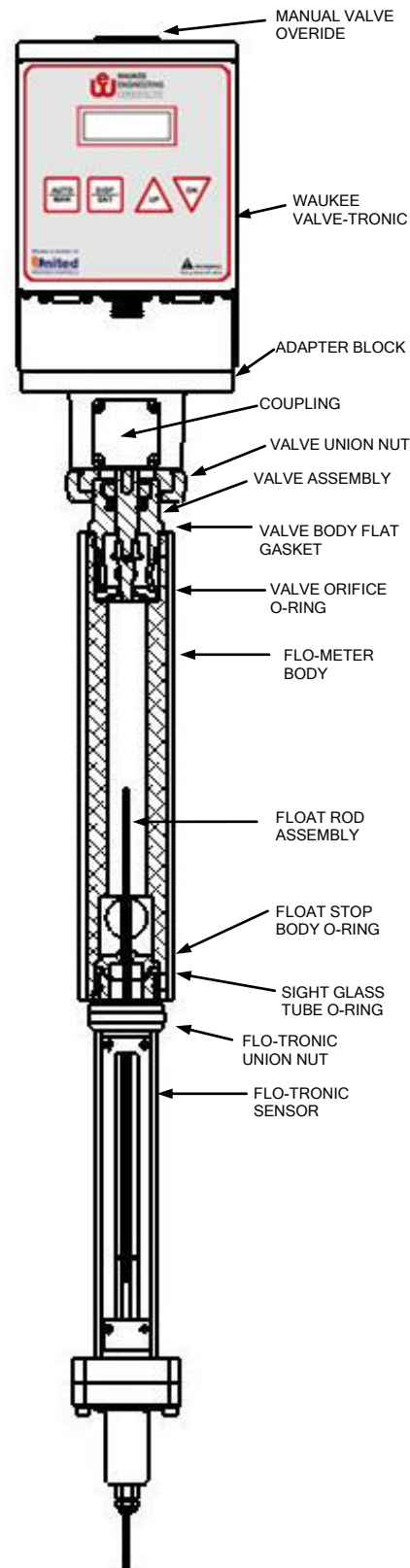

4.2 Valve-Tronic Plus Control Valve Installation

The following instructions are for installing a Valve-Tronic Control Valve onto an existing Waukee Flo-Meter.

1. First remove the valve assembly from the *Valve-Tronic Plus* as follows:
 - i. Remove the Four (4) access window cover plate screws and the access window cover plate.
 - ii. Loosen the valve stem coupling lower hex head set screw.
 - iii. Loosen the valve body union nut.
 - iv. Carefully separate the valve body assembly from the adapter block.
 - v. Set the Valve-Tronic and valve body assembly aside.
2. Remove the cap or manual valve from the existing Flo-Meter using the valve tool provided.
3. Inspect the top of the Flo-Meter and remove any of the following if present: Valve orifice, orifice gasket or valve spring.
4. Insert the “O-Ring” into the top of the Waukee Flo-Meter. Ensure that the “O-Ring” is seated flat against the “shelf” of the Flo-Meter.
5. Insert the orifice on top of the “O-Ring” and ensure that the “O-Ring” is still seated properly.
6. Screw the valve body assembly into top of the Flo-Meter using the valve tool. Tighten until the flat gasket is seated in the Flo-Meter body.



CAUTION: Do not over tighten as damage to the threads may occur.

7. Install the *Valve-Tronic Plus* onto the valve body assembly. Carefully align the valve stem coupling to the valve stem.



CAUTION: Do not force the *Valve-Tronic Plus* onto the valve stem.

8. Tighten the union nut by hand until there is little or no play between the valve body assembly and *Valve-Tronic Plus*.
9. Tighten the valve stem coupling lower hex head set screws.
10. Replace the access window cover plate and Four (4) access window cover plate screws.

4.3 Optional Flow Compensating Pressure/Temperature Sensor Installation

The Pressure/Temperature sensor provides the *Valve-Tronic Plus* with feedback of the actual conditions at the inlet of the Flo-Meter. With this information the *Valve-Tronic Plus* can compensate the flow rate when the pressure or temperature deviates from what the Flo-Meter is calibrated for, which provides extremely accurate measurement of the flow rate and emulates mass flow type flow measurements.

Installation of the sensor requires a Tee at the inlet of the Flo-Meter. The run of the Tee must be large enough to allow the maximum flow through the Flo-Meter, which will require reducing the branch of the Tee for the sensor to ¼” NPT. For best results the sensor must be installed as close to the inlet of the Flo-Meters as possible.

4.4 Wiring Guidelines

Your company may have guidelines for wiring installation. If so, you should check those before you begin the installation. Here are some general things to consider:

- Use the shortest wiring route whenever possible.
- Use shielded wiring for all signal wiring and ground the shield at the Field Device end. **DO NOT** ground the shield at both the *Valve-Tronic Plus* and Field Device.
- Do not run the signal wiring next to large motors, high current switches, or transformers. This may cause noise problems.
- Route the wiring through an approved cable housing to minimize the risk of accidental damage. Check local and national codes to choose the correct method for your application.
- Be sure to leave enough slack in the cables to allow easy removal of the *Valve-Tronic Plus* from the Flo-Meter for maintenance. If seal tight or similar conduit is used, be sure to provide an adequate loop of conduit for maintenance access.



CAUTION: To reduce the risk of electrical shock and also to prevent damage to the Flo-Tronic, *Valve-Tronic Plus* and the Field Device. It is advised to turn off the supply power to the Flo-Tronic, *Valve-Tronic Plus* and Field Device before connecting or disconnecting any wires.



WARNING: Any electrical or mechanical modification to this equipment without prior written consent of United Process Controls will void all warranties, may result in a safety hazard, and may void the CE listing.



WARNING: When making cable assemblies with the included plugs, ensure none of the connections are shorted to each other before plugging into the unit. Failure to verify the cable assembly may result in damage to the unit and may void the warranty.



If you are not experienced in soldering and would prefer a cable assembly Waukee has cable assemblies in a variety of lengths available. Contact your local sales representative or Waukee for information on cable assemblies.



Use 18-22AWG shielded wire for the control signal wiring. It is recommended to run all signal wires in a separate steel conduit. The shield wire should only be connected at the Field Device. Do not connect shield wire on both ends.

4.5 Wiring Terminals

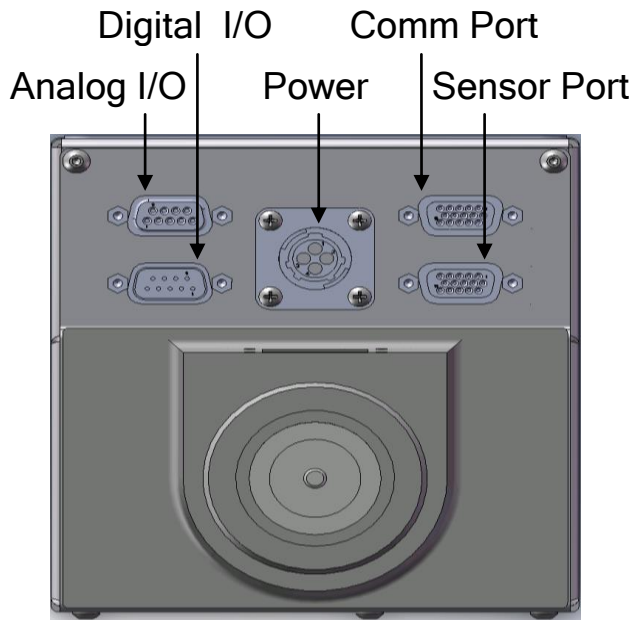

Analog I/O Wiring (9 Pin D-sub Receptacle)		
Pin #	Description	Wire Color
1	Analog In 1 + (AI1)	Red
2	Analog In 1 - (AI1C)	Black
3	N/C	
4	N/C	
5	N/C	
6	N/C	
7	Analog Out 1 + (AO1)	Green
8	Analog Out 1 - (AO1C)	White
9	N/C	

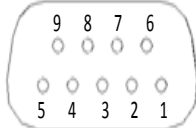

Digital I/O Wiring (9 Pin D-sub Plug)		
Pin #	Description	Wire Color
1	Digital Input + (DI1)	Red
2	N/C	
3	Digital Out 1 N.O.(DO1)	Yellow
4	Digital Out 2 N.O.(DO2)	Orange
5	Digital Out 3 N.O.(DO3)	White
6	Digital Input Com (DCM)	Brown
7	Digital Out 1 Com (DO1C)	Blue
8	Digital Out 2 Com (DO2C)	Violet
9	Digital Out 3 Com (DO3C)	Black

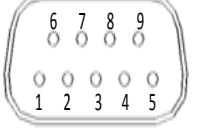

Power Wiring (4 Pin Circular Receptacle)		
Pin #	Description	Wire Color
1	+24VDC	Red
2	DC Common	Black
3	DC Common	White
4	PE	Green

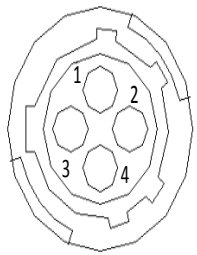

Comm Wiring (15 Pin D-sub Receptacle)		
Pin #	Description	Wire Color
1	Bus RTS	
2	N/C	
3	N/C	
4	ETH RX+	wht/grn
5	ETH RX-	green
6	N/C	
7	ETH TX+	wht/org
8	ETH TX-	orange
9	Bus AL	
10	Bus BL	
11	Bus +5V	
12	N/C	
13	Bus GND	
14	N/C	
15	PE	

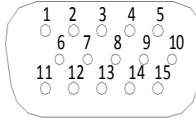

Sensor Wiring (15 Pin D-sub Plug)		
Pin #	Description	Wire Color
1	Flow Sensor + Signal	Green
2	Flow Sensor - Signal	White
3	N/C	
4	N/C	
5	N/C	
6	Flow Sensor Com	White
7	N/C	
8	N/C	
9	Flow Sensor Power	Brown
10	N/C	
11	Pressure Sensor Signal	Green
12	Pres/Temp Sensor Com	Black
13	Temp Sensor Signal	White
14	N/C	
15	Pres/Temp Sensor PWR	Red

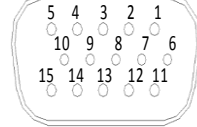

4.6 Power Wiring Diagram

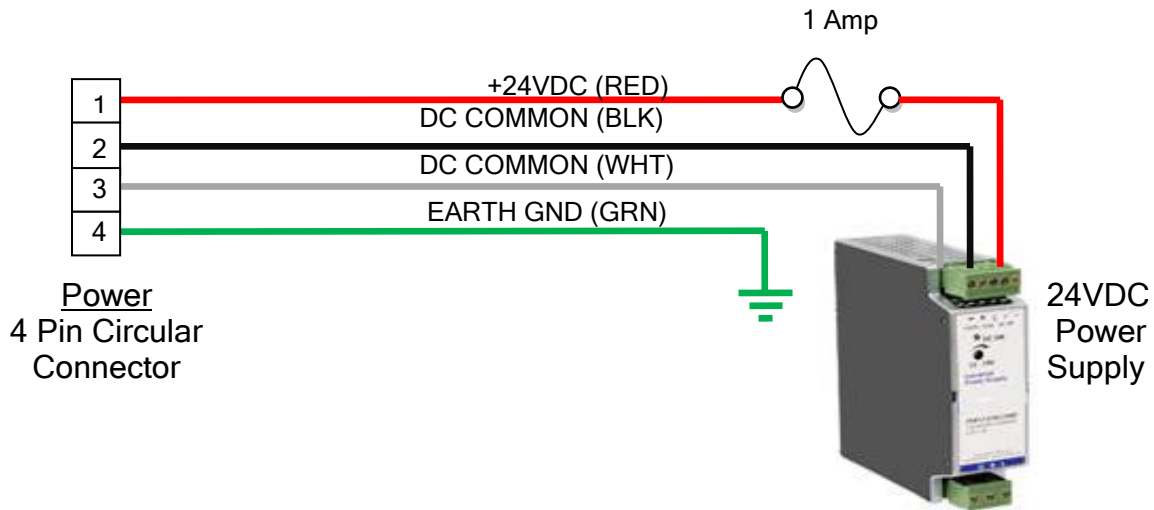

4.7 Control Wiring Diagram

Analog Inputs/Outputs
(9 Pin D-Sub Receptacle)

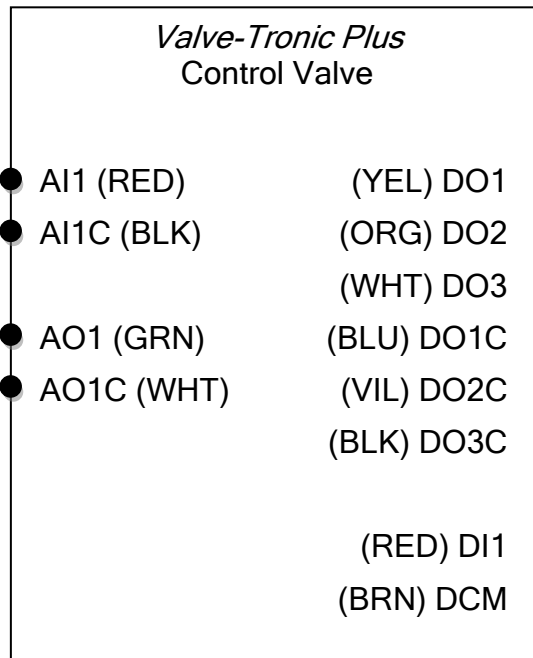
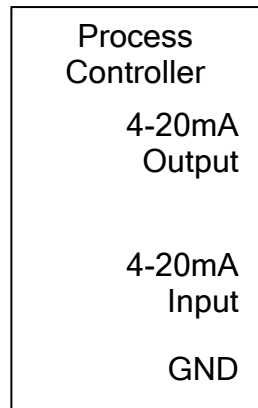

Digital Inputs/Outputs
(9 Pin D-Sub plug)

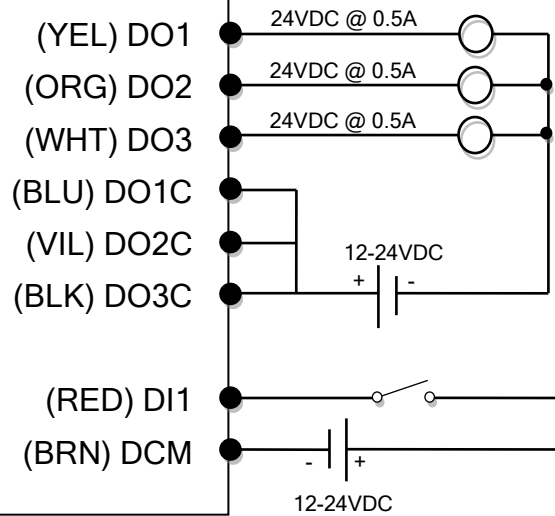

5. CONNECTING TO A LEGACY WAUKEE-TRONIC

The *Valve-Tronic Plus* has the capability of interfacing with our Legacy Waukee-Tronic flow sensors. A Waukee-Tronic conversion cable P/N: TVP-WT005 is required to convert the signal from the Waukee-Tronic to a signal that is understood by the *Valve-Tronic Plus* Sensor input. Wiring of the Waukee-Tronic to a *Valve-Tronic Plus* utilizing this cable is shown below.

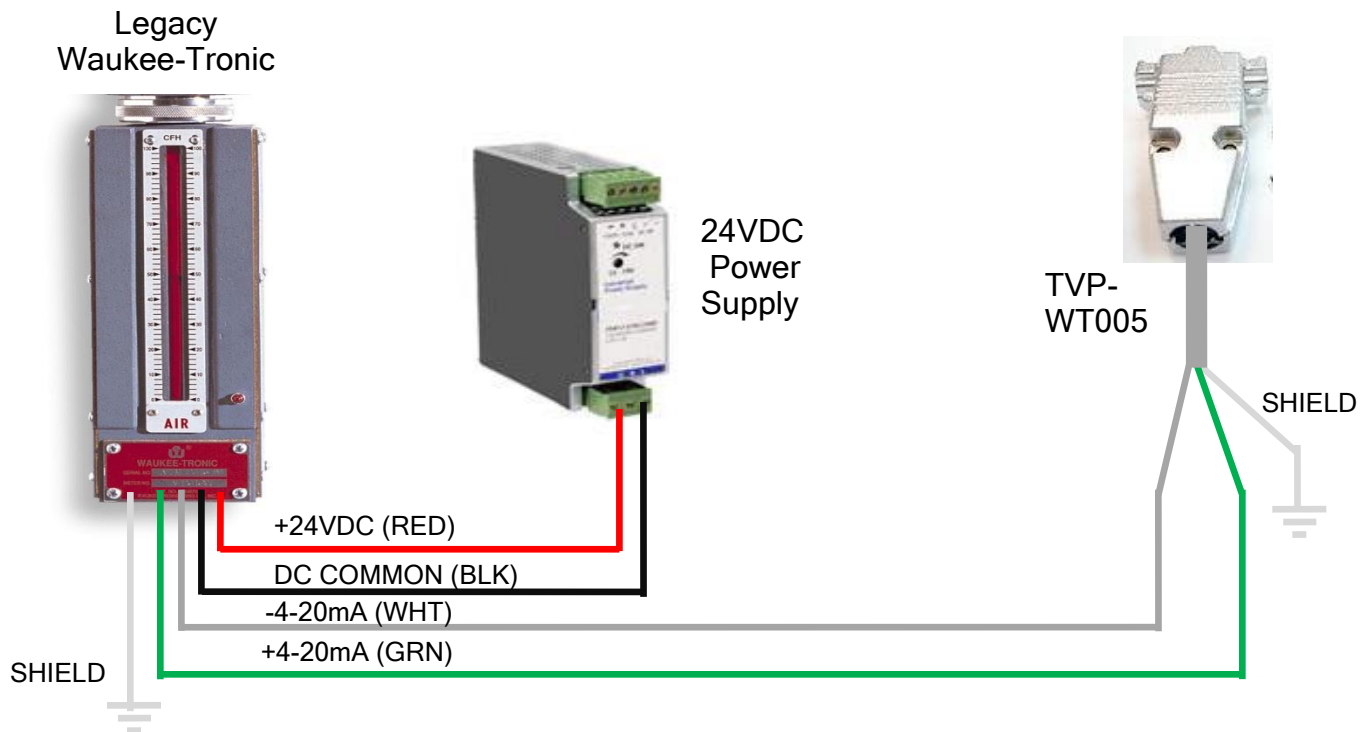

6. POSITIVE SHUT-OFF

The control valve provided with the *Valve-Tronic Plus* is a needle valve designed specifically to precisely control the rate of flow. This valve is not intended to be used as a means of positive shut-off. Even when the valve is fully closed a small amount of leakage may be noted.



WARNING: The control valve on the *Valve-Tronic Plus* is not designed as a positive shut-off valve, a ball valve or similar type valve should be installed up stream of the Flo-Meter before servicing equipment that the Flo-Meter is servicing.

If the process is sensitive to this leakage flow or if positive shut-off is desired, a solenoid valve may be added.

6.1 Solenoid Valve Sizing and Location

When selecting a solenoid valve make sure it is capable of supplying the flow required at the operating pressure. Waukee Flo-Meters require a constant inlet supply pressure and if the solenoid valve does not have a large enough orifice, or CV factor, it may have an effect on the supply pressure at the inlet of the Flo-Meter which may affect its accuracy. For this reason among others, United Process Controls Inc. recommends installation of the solenoid valve at the outlet of the Flo-Meter.

6.2 Controlling the Solenoid Valve

There are many combinations of wiring and controlling the solenoid valve. When closing the solenoid valve you want to ensure that the *Valve-Tronic Plus* Control Valve drives closed. This can be achieved many ways, some of which are:

1. Configure the process controller that is controlling both the *Valve-Tronic Plus* and solenoid valve, so that when the solenoid valve is closed that it sends a control signal of 4.5mA or less to the Analog inputs (AI1, AI1C). This will tell the *Valve-Tronic Plus* to drive the valve closed regardless of feedback signal from the flow sensor.
2. Configure the Valve-Tronic's Digital Input (DI1, DCM) via the programming parameter P3.00 = "01: Closed Valve N.O.". Then wire these contacts to a dry N.O. contact on the process controller. Setup the process controller to close these contacts when the solenoid valve is closed. When the process controller closes these contacts the Valve will drive closed regardless of what the control or feedback signal is.

These are just two examples of how to properly use a solenoid valve with a *Valve-Tronic Plus* Flo-Meter. The main objective is that the control valve must drive closed whenever the solenoid valve is closed.



CAUTION: Failure to configure and wire a solenoid valve as mentioned above may result in over gassing of equipment or may cause damage to the float rod assembly within the Flo-Meter due to a sudden in-rush of flow spiking the Flo-Meter.



WARNING: When using a solenoid valve be sure to select the proper solenoid configuration for fail safety (N.O. or N.C.)

7. KEYPAD OPERATION AND DISPLAY OVERVIEW

7.1 Keypad

The digital keypad includes a graphics LCD display and 4 function keys.

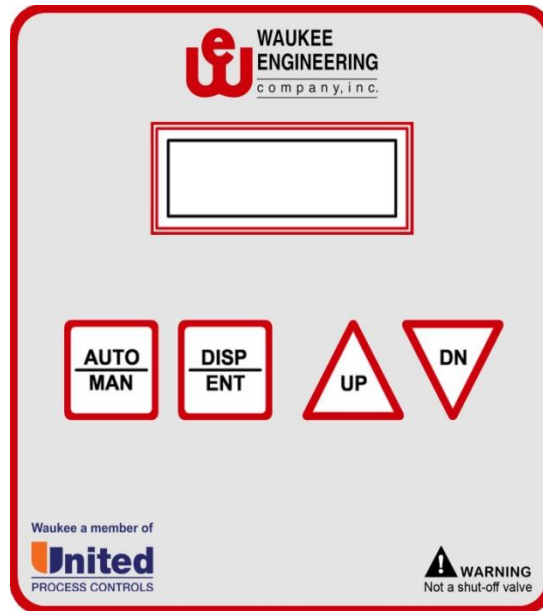

7.2 LCD Display

The LCD Display shows the operation values, parameters and faults

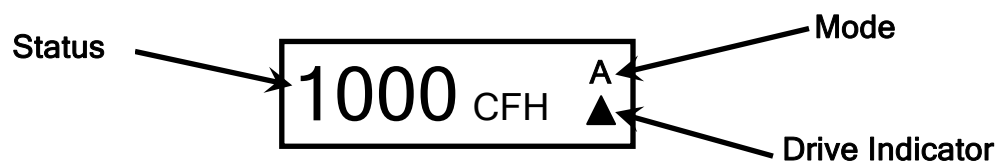

Mode

Displays the mode of operation as follow:

- A - Automatic Mode
- M - Manual Mode

Drive Indicator

Indicates direction of valve travel and relative speed related to how fast the indicator is flashing.

Status

Displays status of unit, for a complete list of status screens refer to pg. 18 “Displaying the status of the Valve Tronic Plus”

7.3 Function Keys

AUTO/MAN Key

Pressing the AUTO/MAN key will change the mode of operation.

DISP/ENT Key

Pressing the DISP/ENT key on the keypad repeatedly will cycle through the status messages of the Control Valve. It is also used in the programming mode to select and view parameters as well as store parameter settings.

UP/DN Key

When the control valve is in the manual mode the UP key will drive the valve open and the DN key will drive the valve closed. The UP/DN keys are also used to scroll through the parameter groups, the various parameters in each group and also changes the parameter settings in single-unit increments. To quickly run through the range of settings, press and hold the UP or DN key.



After a one (1) minute key inactivity, the keypad LCD display will automatically revert to the main display.

7.4 Displaying the status of the Valve-Tronic Plus

Press the DISP/ENT key on the keypad repeatedly to cycle through the status messages on the control valve. The diagram below shows the order of the status messages as you cycle through them and shows the definition of the status messages.

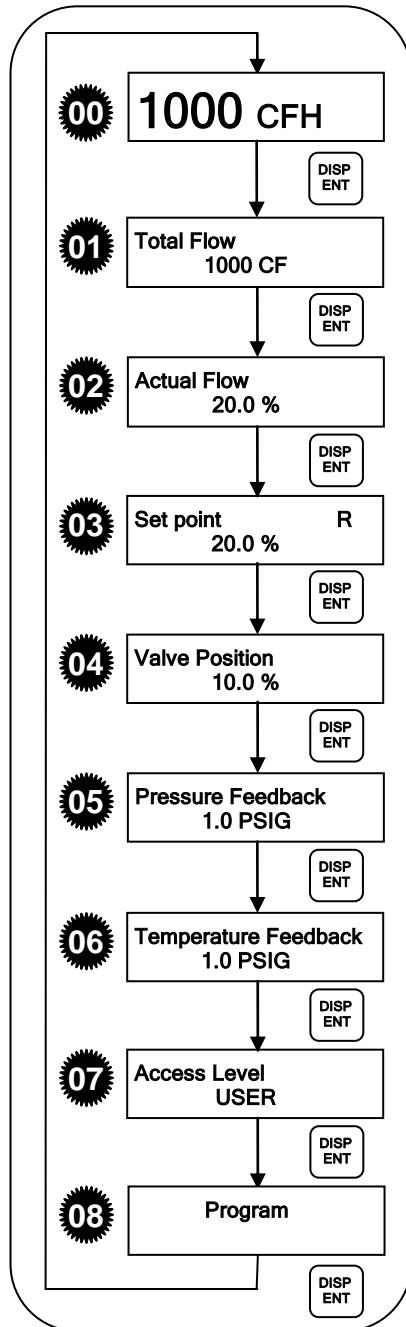

- 00 Main Page***
This is the main page that shows either the actual flow rate in engineering units or % valve position depending on configuration. It also displays alarm messages and mode.
- 01 Totalized Flow**
Displays the total flow that has flowed through the Flo-Meter. Note: it is possible to reset the totalized flow by pressing and holding the ▼ key for 5 seconds.
- 02 Actual Flow (%)**
Displays the feedback signal from the Flo-Tronic flow sensor in % of flow
- 03 Set point**
Displays the set point. Note: it is possible to change the set point with the ▲ and ▼ keys when the set point value is displayed on the keypad and unit is set to Local “L” setpoint mode. To change from Remote “R” to Local “L” press the Auto/Man mode key.
- 04 Valve Position / Actual Flow***
Depending on the configuration this page will display either the % position of the control valve or actual flow rate in engineering units.
- 05 Pressure Feedback**
Displays actual supply pressure in engineering units to the inlet of Flo-Meter. Note: the pressure/temperature sensor is an optional sensor; if unit is not equipped with this sensor this status display will not be visible.
- 06 Temperature Feedback**
Displays actual supply fluid temperature in engineering units to the inlet of the Flo-Meter. Note: the pressure/temperature sensor is an optional sensor; if unit is not equipped with this sensor this status display will not be visible.
- 07 Access Level**
Displays the current level of accessibility to the *Valve-Tronic Plus*. Visible only when the default access level P2.07 is set to “01:User” See “Access Levels of the *Valve-Tronic Plus*” on page 19.
- 08 Program Mode**
Used to program parameters within the unit. For programming, see “Programming the *Valve-Tronic Plus* on page 20.

*When Control Type P1.09 is set to “00: Flow” the Main Page (01) will display Actual Flow and page (04) will display % Valve Position. When set to “01: Position” the two display pages will swap so % Valve Position will become the Main Page (01)

7.5 Alarm Status of the Valve-Tronic Plus

When Alarms are programmed to trigger (P3.01 and P3.03 set to 01 thru 06) the status screen will cycle through the alarms triggered and the main screen. The diagram below shows the order of the alarm status messages. The display will continue to cycle until all alarms are cleared.

Alarm Message

Displays how the alarm is programmed.

Refer to “Digital I/O Parameters” P3.01 thru P3.03 for alarm programming. Alarm messages are as follow:

- Valve Full Open
- Valve Full Closed
- Fault
- High Flow Alarm
- Low Flow Alarm
- Totalizer Alarm

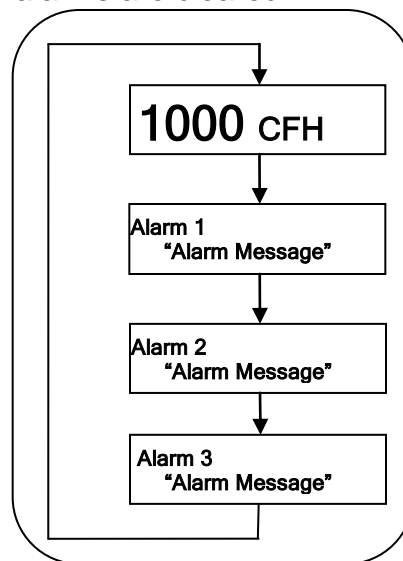

7.6 Access Levels of the Valve-Tronic Plus

The Valve-Tronic Plus has the capability to lock out parameter settings and data entry screens, requiring a pass code to change values. By Default the Valve-Tronic Plus is setup with an Access Level of “Admin” which provides the operator full access to all parameter settings and data entry. If desired the default Access Level can be changed to “User”. The “User” Access Level can view but not change any parameter settings (Read Only) and data entry screens have the option to be “Ready Only” or “Read/Write”. For information regarding setting up Access Levels refer to the programming section of the manual

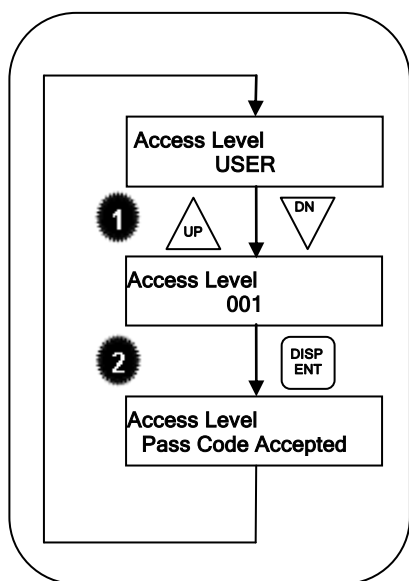

Entering Pass Code

- 1 Press the ▲ or ▼ key to change the pass code in increments or decrements of 1.
- 2 Once the correct pass code is entered press the DISP/ENT Key.

If the pass code is correct the display will show “Pass Code Accepted” otherwise it will show “Pass Code Denied”, and then show the current Access Level.



Once the correct pass code is entered you will have access to that level of access until 5 minutes of keypad inactivity. After 5 minutes of keypad inactivity the access level reverts back to the default Access Level. If the default Access level is “ADMIN” then there is no need to enter a pass code.

7.7 Programming the Valve-Tronic Plus

The Valve-Tronic Plus Control Valve parameters are organized into six (6) different groups according to their functions. The illustration below shows you how to navigate through the parameter groups and parameter settings. For a complete list of parameters, see Pgs. 19 thru 23.

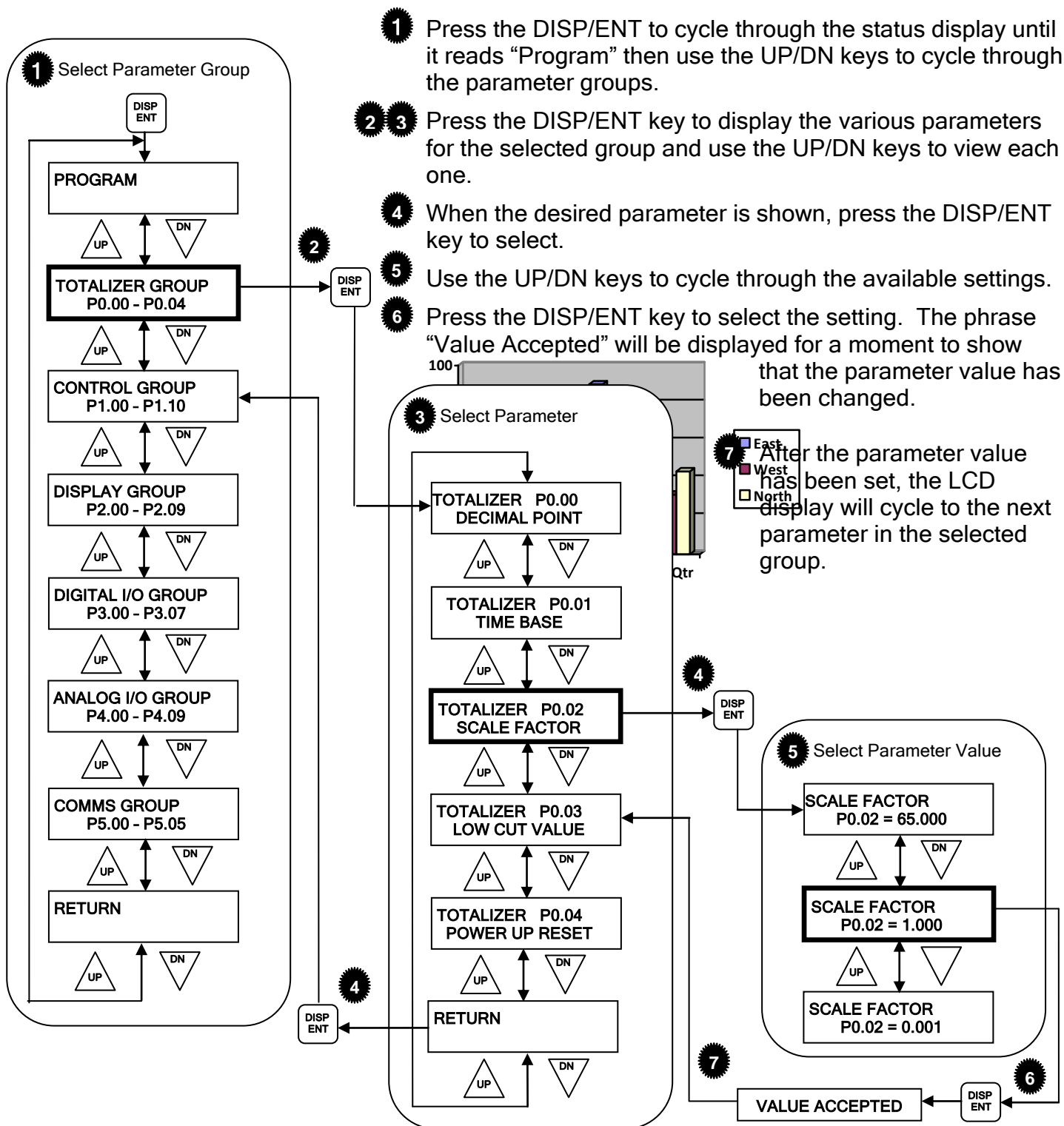

8. CONTROL VALVE PARAMETERS

Parameter Summary				
Parameter	Description	Range	Default Setting	User Setting
Totalizer Parameters				
P0.00	Decimal Point	0 0.0 0.00 0.000 0.0000	0	
P0.01	Scale Factor	0.001 to 65.000	1.000	
P0.02	Low Cut Value	-10 to 99999	0	
P0.03	Power UP Reset	00: Do Not Reset 01: Reset	00	
P0.04	Max Value for A0	0 to 99999	99999	
Control Parameters				
P1.00	Setpoint Source	01: Analog Input 02: Communication	01	
*P1.01	PID Gain	0 to 100%	Factory Cal.	
*P1.02	PID Reset	0.00 to 50.00 min.	Factory Cal.	
*P1.03	PID Rate	0.0 to 10.0 min.	Factory Cal.	
*P1.04	PID Filter	0.0 to 10.0 sec.	1.0	
P1.05	Dead Band	0.5 to 5.0%	1.0	
*P1.06	PID Delay	0.0 to 60.0 sec.	Factory Cal.	
P1.07	Control Mode	00: Direct 01: Reverse	00	
P1.08	Control Range	00: 4-20mA 01: 4-12mA 02: 12-20mA	00	
P1.09	Control Type	00: Flow 01: Position	0	
**P1.10	100% Valve Position	Press DISP/ENT to Calibrate	N/A	
Display Parameters				
P2.00	Flow Units	00: CFH 01: M3H 02: L/H 03: GPH	00	
P2.01	Flo-Meter Scale	1.0 - 99999.9	100.0	
P2.02	Temperature Units	00: °F 01: °C	00	
*When Control Type P1.09 = 00: Position, Parameter not visible				
**When Control Type P1.09 = 01: Flow, Parameter not visible				

Parameter Summary (continued)				
Parameter	Description	Range	Default Setting	User Setting
Display Parameters (continued)				
P2.04	Language	00: English 01: Spanish 02: German 03: Chinese	00	
P2.05	Default Access Level	00: Admin 01: User	00	
** P2.06	Admin Pass Code	0-999	462	
** P2.07	Set-point Access	00: Enable 01: Disabled	00	
** P2.08	Totalizer Reset Access	00: Enable 01: Disabled	00	
P2.09	Restore To Defaults	Yes/No	N/A	
Digital I/O Parameters				
P3.00	Multi-function Input Terminal (DI1)	00: Input Disabled 01: Close Valve (N.O.) 02: Close Valve (N.C.) 03: Reset Totalizer 04: Enable Totalizer	00	
P3.01	Multi-function Output Terminal (DO1)	00: Output Disabled 01: Valve Full Open 02: Valve Closed	00	
P3.02	Multi-function Output Terminal (DO2)	03: Fault 04: High Flow Alarm	00	
P3.03	Multi-function Output Terminal (DO3)	05: Low Flow Alarm 06: Totalizer Alarm	00	
* P3.04	High Flow Alarm Setpoint	1-99999	99999	
* P3.05	Low Flow Alarm Setpoint	0-99999	0	
* P3.06	Totalizer Alarm Setpoint	0-99999	99999	
P3.07	Output Logic	00: N.O. 01: N.C.	01	
* Parameter Only Functions when a Multi-Function Terminal is set to trigger the alarm.				
** Parameter only visible when P2.07 = 01:User				

Parameter Summary (continued)

Parameter	Description	Range	Default Setting	User Setting
Analog I/O Parameters				
* P4.00	Loss of Control Signal (AI1)	00: Continue Operation by last command 01: Drive valve closed 02: Maintain current valve position	00	
P4.01	Loss of Flo-Tronic Sensor Signal	00: Maintain current valve position 01: Drive valve closed	00	
P4.02	Analog Output Signal (AO1)	00: Actual Flow Rate 01: Totalizer Display Value	00	
P4.03	Pres/Temp Sensor Input	00: Disabled 01: Enabled	00	
P4.04	Flo-Tronic Flow Sensor Null	Press DISP/ENT to Calibrate	Factory Calibrated	
P4.05	Flo-Tronic Flow Sensor Bias	-999 to 9999	Factory Calibrated	
Communications Parameters				
P5.00	IP Address	0.0.0.0 thru 254.254.254.254	0.0.0.0	
P5.01	Subnet Mask	0.0.0.0 thru 255.255.255.255	0.0.0.0	
P5.02	Gateway	0.0.0.0 thru 254.254.254.254	0.0.0.0	
P5.03	MAC Address	Set at Factory		
P5.04	Module ID	1 thru 63	1	
P5.05	Comm Time-Out	0 to 600	10	
* If P1.0 "PID control signal source" is set to "00: keypad" parameter will default to 00.				

9. DETAILED PARAMETER LISTINGS

Parameter Number	Parameter Name	Default Setting
P0.00	Totalizer Decimal Point	Default Setting: 0
	Settings: 0 0.0 0.00	
	This parameter sets the resolution of the totalizer.	
	Parameter Setting Range	Parameter Description

Totalizer Parameters

P0.00	Totalizer Decimal Point	Default Setting: 0
	Settings: 0 0.0 0.00	
	This parameter sets the resolution of the totalizer.	
P0.01	Totalizer Scale Factor	Default Setting: 1.000
	Range: 0.001 to 65.000	
	For most applications, the totalizer reflects the same decimal point location and engineering units as the Input Display. In these cases, the Totalizer Scale Factor is 1.000. The Totalizer Scale Factor can be used to scale the Totalizer to a different value than the input display. Common possibilities are:	
	<ol style="list-style-type: none"> 1. Changing decimal point location 2. Average over a controlled time frame 	
P0.02	Totalizer Low Cut Value	Default Setting: 0
	Range: -10 to 100	
	This parameter sets a low cut value that disables the totalizer when the input display value falls below this programmed value.	

P0.03**Totalizer Power Up Reset**

Default Setting: 00: Do Not Reset

Setting: 00: Do Not Reset
01: Reset

This parameter determines if the totalizer resets after powering up the unit or maintain current count.

P0.04**Totalizer Max Value for AO**

Default Setting: 99999

Range: 0 to 99999

This parameter determines the value of the Totalizer that will result in a 20mA output

Control Parameters**P1.00****Set point Source**

Default Setting: 01: Analog

Setting: 01: Analog Input
02: Communications

This parameter sets the source of command signal.

P1.01**PID Gain**

Default Setting:

Range: 0 to 100%

The First parameter of PID control is Proportional Control (Gain). For a given process, if the Gain value is set too low, the control action will be too sluggish. If the Gain value is too high, the control action will be unstable (erratic).

Set the Integral (Reset) and Derivative (Rate) to (0). Begin tuning the process with a low Gain value, and increase the Gain value until the system goes unstable (erratic) when instability is reached; reduce the Gain value slightly until the system becomes stable. Stability can be tested by moving between two wide-spread set point values.

The Default setting for this parameter varies depending on application.

P1.02**PID Reset**

Default Setting: Varies

Range: 0.00 to 50.00 min.

Using only the proportional control, the corrective action may not increase fast enough or the set point may never be reached because of system losses. The Integral control (Reset) is used to generate additional corrective action.

When tuning, begin with a large Reset value and reduce the value until the system goes unstable (erratic). When instability is reached, increase the Reset value slightly until the system becomes stable and the desired set point value is reached.

P1.03**PID Rate**

Default Setting: 0

Range: 0.00 to 10.00 min.

Using only the proportional control, the corrective action may not increase fast enough or the set point may never be reached because of system losses. The Integral control (Reset) is used to generate additional corrective action.

When tuning, begin with a large Reset value and reduce the value until the system goes unstable (erratic). When instability is reached, increase the Reset value slightly until the system becomes stable and the desired set point value is reached.

For most applications a value of 0 min. will be used.

P1.04**PID Filter**

Default Setting: 1.0

Range: 0.00 to 10.0 sec

To avoid amplification of measured noise in the control output, a filter is inserted. This filter helps smooth oscillations. Larger values provide more smoothing.



Parameters P1.01 Thru P1.04 are not visible when P1.09
“Control Type” is set to 00: Position

P1.05**Dead Band**

Default Setting: 1.0

Range: 0.5 to 5.00%

To avoid continual correction of flow, a deadband is added. This deadband is a percentage of set-point flow. When control valve is within deadband no correction will be made until PV is out of the deadband.

P1.07**Control Mode**

Default Setting: 00: Direct

Settings: 00: Direct
01: Reverse

This parameter selects the action of the control valve in relation to the Control Signal.

Setting 00: Direct Acting Mode - a 4mA control signal corresponds to Zero “0” flow and a 20mA control signal corresponds to full flow.

Setting 01: Reverse Acting Mode - a 20mA control signal corresponds to Zero “0” flow or closed valve and a 4mA control signal corresponds to 100% flow or full flow.

P1.08**Control Range**

Default Setting: 00: 4-20mA

Settings: 00: 4-20mA
01: 4-12mA
02: 12-20mA

This parameter selects the control signal range that the valve responds to.

(Ex. When the parameter is set to “01”, 4mA will correspond to Zero “0” flow and 12mA will correspond to full flow.)

P1.09**Control Type**

Default Setting: 00: Flow

Settings: 00: Flow
01: Position

This parameter selects the control Type where:

00: Flow - Control is based on flow rate. The Main page will display actual flow rate in engineering units.

01: Position - Control is based on Valve Position. The Main page will display % Valve Position.

P1.10**100% Valve Position**

Default Setting: N/A

This parameter is used to set the 100% valve position for Automatic Mode when control type P1.09 is set to 01: Position



Parameters P1.10 is visible when P1.09 “Control Type” is set to 01: Position

Display Parameters

P2.00	Flow Units	Default Setting: 00: CFH
	Settings: 00: CFH 01: M3H 02: L/H 03: GPH Flow units to display on LCD display. Also determines units for P2.01.	
P2.01	Flo-Meter Scale	Default Setting: 100.0
	Range: 1.0 to 99999.9 Scale of Flo-Meter Control Valve is being used on	
P2.02	Temperature Units	Default Setting: 00: °F
	Settings: 00:°F 01:°C Temperature units to display on LCD display. Also determines units for P2.03	
P2.04	Language	Default Setting: 00: English
	Settings: 00: English 01: Spanish 02: German	
P2.05	Default Access Level	Default Setting: 00: Admin
	Settings: 00: Admin 01: User Sets The Default Access level for the <i>Valve-Tronic Plus</i> where: Admin = Full Access User = Read Only Access	
P2.06	Admin Pass Code	Default Setting: 462
	Range: 0 to 999 Sets the Admin Pass Code	
P2.07	Set point Access	Default Setting: 00: Disabled
	Settings: 00: Disabled 01: Enable Enable this setting to allow the User Access Level to change the PID Set point.	

P2.08**Totalizer Reset Access**

Default Setting: 00: Disabled

Settings: 00: Disabled

01: Enable

Enable this setting to allow the User Access Level to reset the totalizer.

P2.09**Restore To Defaults**

Settings: Yes/No

Restarts all parameters to factory defaults



P2.08 thru P2.10 are only Visible when P2.07 is set to 01: User

Digital I/O Parameters**P3.00****Multi-function Input Terminal (DI1)**

Default Setting: 00: None

Settings: 00: None

01: Closed Valve (N.O.)

02: Closed Valve (N.C.)

03: Reset Totalizer (N.O.)

04: Enable Totalizer (N.O.)

Setting 00: No action**Setting 01 and 02:** When a signal is received, the control valve will drive closed and the words “Closed Valve” will display on the LCD display and inhibit operation. To resume normal operation, these contacts must be cleared.**Setting 03:** When a signal is received, the control valve will reset the totalized flow to “0”**Setting 04:** When a signal is received, the control valve will enable totalization of flow. When signal is not received flow totalizer will stop totalizing.**N.O.** - Control Valve receives signal when N.O. contact closes**N.C.** - Control Valve receives signal when N.C. contact opens**P3.01****Multi-function Output Terminal (DO1)**

Default Setting: 00: None

P3.02**Multi-function Output Terminal (DO2)**

Default Setting: 00: None

P3.03**Multi-function Output Terminal (DO3)**

Default Setting: 00: None

Settings for P3.01 thru P3.03

- 00: None
- 01: Valve Full Open
- 02: Valve Closed
- 03: Fault
- 04: High Flow Alarm
- 05: Low Flow Alarm
- 06: Totalizer Alarm

Setting 00: No action**Setting 01:** Valve full open - The terminals will be activated when the valve is fully open.**Setting 02:** Valve Closed - The terminals will be activated when the valve is fully closed.**Setting 03:** Fault - The terminals will be activated when the Control Valve has a error or Problem.**Setting 04:** High Flow Alarm - The terminals will be activated when the flow is above High Flow Alarm Setpoint set in P3.04**Setting 05:** Low Flow Alarm - The terminals will be activated when the flow is below Low Flow Alarm Setpoint set in P3.05**Setting 06:** Totalizer Alarm - The terminals will be activated when the totalized flow is Above Totalizer Alarm Setpoint, set in P3.06**P3.04****High Flow Alarm Setpoint**

Default Setting: 99999.9

Range: 0.0 to 99999.9

High Flow Alarm Setpoint

P3.05*Low Flow Alarm Setpoint**

Default Setting: 0.0

Range: 0.0 to 99999.9

Low Flow Alarm Setpoint

P3.06*Totalizer Alarm Setpoint**

Default Setting: 99999.9

Range: 0.0 to 99999.9

Totalized Flow Alarm Setpoint

*Units are same as set in P2.0

P3.07**Output Logic**

Default Setting: 01: N.C.

Settings: 00: N.O.
01: N.C.

This parameter selects the Logic of the output contacts.

Setting 00: N.O. - Contact closure when alarm condition exists**Setting 01:** N.C. - Contact opens when alarm condition exists

Analog I/O Parameters

P4.00

Loss of Control Signal (AI1) Default Setting: 00: Cont. oper. By last command

Settings: 00: Continue operation by last command

01: Drive valve closed

02: Maintain current valve position

Action control valve should take in the event that the control signal is lost.

P4.01

Loss of Flo-Tronic Sensor Signal Default Setting: 00: Maint. Current Pos.

Settings: 00: Maintain current valve position

01: Drive valve closed

Action control valve should take in the event that the Flo-Tronic Flow Sensor signal is lost.

P4.02

Analog Output Signal (AO1) Default Setting: 00: Actual flow rate

Settings: 00: Actual flow rate

01: Totalizer display value

This parameter selects either Actual flow rate or totalizer display value to be retransmitted on AO1 output terminals.

P4.03

Flo-Tronic Flow Sensor Null Default Setting: Factory Calibrated

This parameter is used to calibrate the zero (0) flow feedback from the Flo-Tronic sensor. If the unit does not display zero (0) when the Flo-Meter is reading zero (0) flow then press the “ENT/DISP” key to accept the new zero.



Before setting the Null, ensure that the Flo-Meter is reading zero flow. Failure to do so will result in undesirable operation.

P4.04

Flo-Tronic Flow Sensor Bias Default Setting: Factory Calibrated

Range -999 thru 9999

This parameter is used to calibrate the flow feedback signal from the sensor. If the unit does not display the proper flow reading when compared to the Flo-Meter, this value can be adjusted to make the unit read correctly.

Communications Parameters

P5.00**IP Address**

Default Setting: 0.0.0.0

Range: 0.0.0.0 to 254.254.254.254

If the Control Valve is controlled by communications, the IP address must be set via this parameter. Every component connected to the same network must have a unique IP address. Normally a network administrator will assign an IP address to each device on the network



WARNING: It is extremely important not to have duplicate IP Addresses on your network. If you are using the IP Address to link the Control Valve to any network devices (PCs or PLCs), the Control valve must have a unique number.

P5.01**Subnet Mask**

Default Setting: 0.0.0.0

Range: 0.0.0.0 to 255.255.255.255

If the Control Valve is controlled by communications, the Subnet Mask must be set to the correct network class. If you do not know your Subnet Mask, ask your network administrator.

P5.02**Gateway**

Default Setting: 0.0.0.0

Range: 0.0.0.0 to 254.254.254.254

If the Control Valve is controlled by communications, the Gateway must be set to the IP address of the Router. If you do not know your Gateway address, ask you network administrator.

P5.03**MAC Address**

Default Setting: Set at Factory

A unique Ethernet (MAC) Address is assigned to each module at the factory and will not change. The Ethernet (MAC) Address is a twelve digit number with no deliberate relationship to your network or functional areas of your plant. It does not usually serve as a convenient and easily remembered identifier.

P5.04**Module ID**

Default Setting: 1

Range: 1 to 64

If the Control Valve is controlled by communications, the Module ID must be set. The Module IDs must be unique for each Control Valve, but they do not have to be in sequence.

P5.05**Comm Time-Out**

Default Setting: 10

Range: 0 to 600 Seconds

10. WEB INTERFACE MANAGEMENT & CONFIGURATION

All *Valve-Tronic Plus* Control Valves include a build in web interface. Besides being easy to use, the Web Interface includes the following features:

- Easy viewing and setup of parameter settings
- Viewing and exporting of Event Log
- Firmware upgrade capability
- Backing up and restoring of configuration
- Remotely view status of unit

10.1 System Requirements

- PC with Network Interface Card (NIC)
- Windows operating system with Internet Explorer 6.0 or higher

10.2 Establish Communication Link to PC

Setup the Communication Link

Connect Tronic Valve Plus Cross Over Cable P/N: TVP-EX015 to Communication Port of *Valve-Tronic Plus* and network interface card (NIC) on the PC.

Step 1: Get IP Address of Unit

On the *Valve-Tronic Plus* go to PROGRAM>COMMS GROUP>IP ADDRESS to get IP Address and go to the next parameter GATEWAY to get the gateway.

Step 2: Open Connection Manager on PC

On the PC go to START>CONTROL PANEL> NETWORK CONNECTIONS to bring up the connection manager.

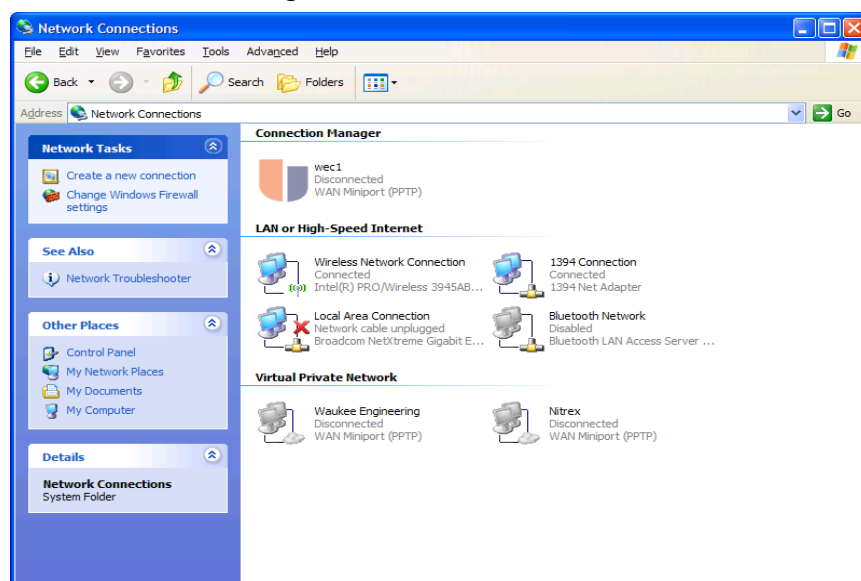

Step 3: Open Network Properties

Double-click on the connection that the *Valve-Tronic Plus* is connected to. This will bring up the Network Properties for that connection

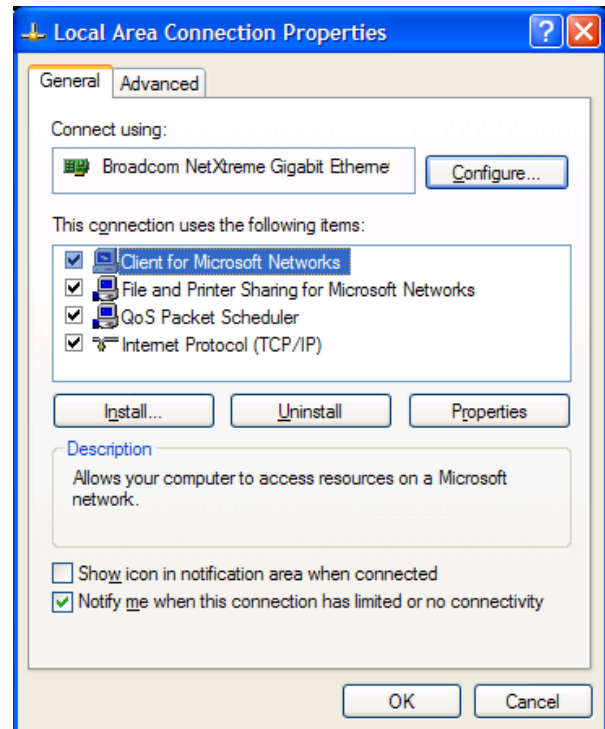

Step 4: Open Internet Protocol (TCP/IP) Properties

Double-click on “Internet Protocol (TCP/IP)” to bring up the Internet Protocol (TCP/IP) Properties.

Change Radio button to “Use the following IP address”

For the **IP address**: use the first three numbers that you noted from Step 1, the last number of the address can be anything between 0 and 255 as long as it is not the same as the *Valve-Tronic Plus*. For example if the IP address of the *Valve-Tronic Plus* is “192.168.5.23” you would type in the address as shown to the right. Notice the last number in the address is “10” but this could be any number other than “23”.

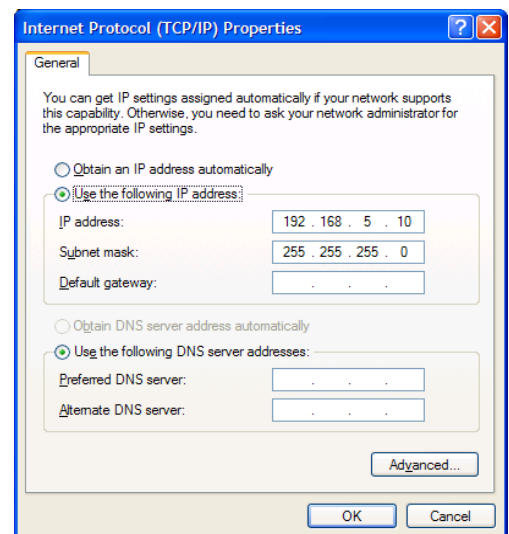

For the **Subnet mask** uses the same as noted in step 1 in this example it is 255.255.255.0

Leave all other fields blank and click on **OK**

Step 5: Open Internet Explore

Type the address of the *Valve-Tronic plus* as noted in step 1 into the address bar of Internet Explore and press **Enter**

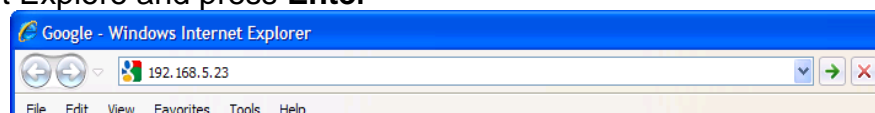

Step 6: Enter **User name:** of “vtadmin”
 Enter **Password:** of “vtapw”
 Then Click on **OK**

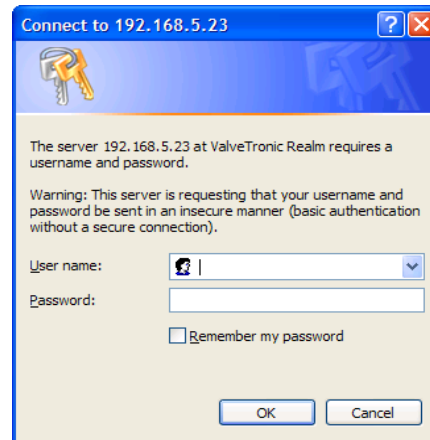

10.3 Exploring the Interface

Now that your PC and *Valve-Tronic Plus* are linked together you will be able to perform any tasks via the web interface. The Web interface works just like any website which makes it very easy to navigate.

Home Page

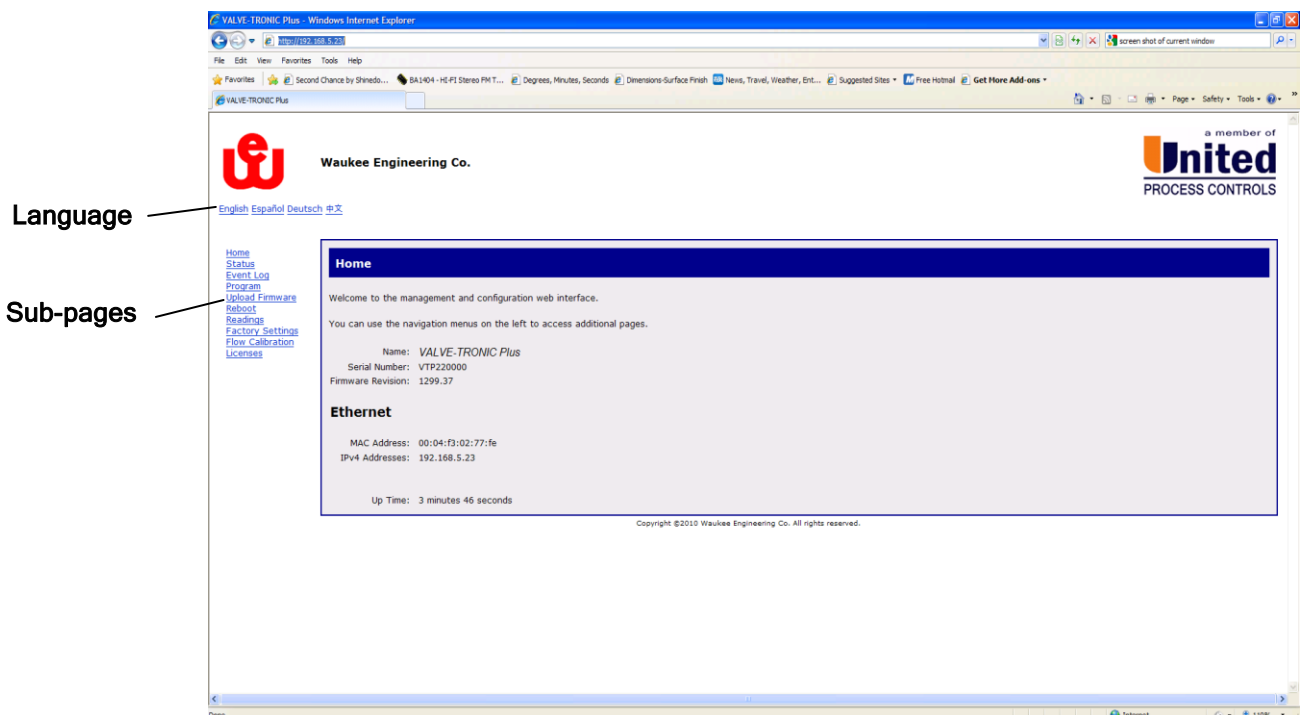

Language: Select desired language

Sub-pages: Click on the text to goto the desired sub-page.

Sub-pages “Readings”, “Factory Settings” and “Flow Calibration” are only accessible by factory personnel

Name: Shows the Product Name

Serial Number: Shows Serial Number of Unit

Firmware Revision: Shows the current firmware version

MAC Address: Shows the MAC address of the Unit

IPv4 Address: Shows the IP Address of the Unit

Status Page

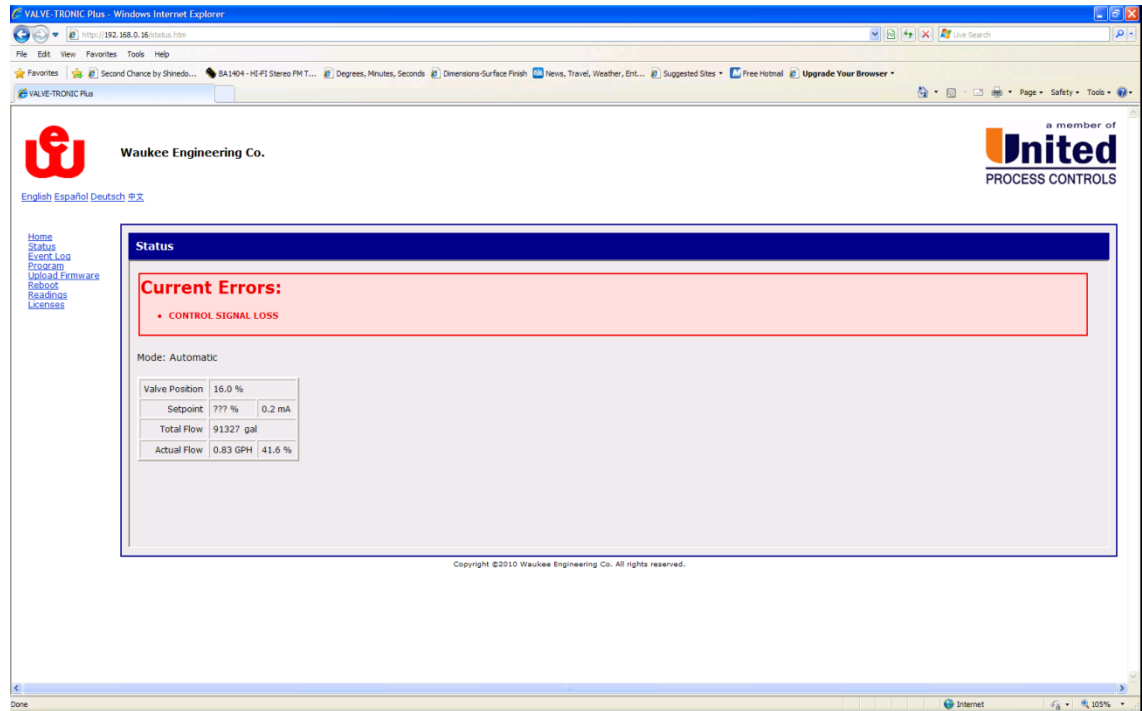

Current Errors: Shows a list of current errors

Mode: Shows the current mode of operation (Auto or Manual)

Valve Position: Shows current valve position in % open

Setpoint: Shows the set-point in % as well as mA if unit is configured to receive its setpoint signal from AI Analog Input

Total Flow: Shows the totalized flow

Actual Flow: Show the current actual flow rate in Engineering units as well as % of Scale

Event Log Page

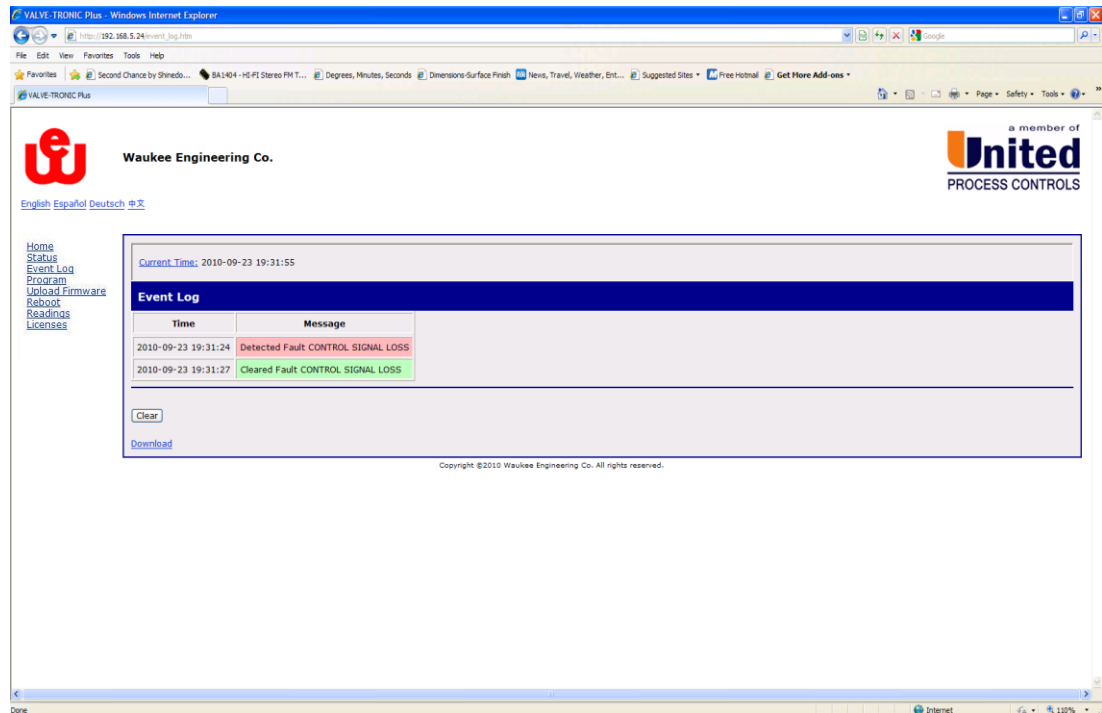

Waukee Engineering Co. a member of
United
PROCESS CONTROLS

English Español Deutsch

Home
Status
Event Log
Program
Upload Firmware
Reboot
Readings
Licenses

Current Time: 2010-09-23 19:31:55

Time	Message
2010-09-23 19:31:24	Detected Fault CONTROL SIGNAL LOSS
2010-09-23 19:31:27	Cleared Fault CONTROL SIGNAL LOSS

Clear
Download

Copyright ©2010 Waukee Engineering Co. All rights reserved.



Current Time: Shows the current date and time set in the unit. To change the date and time, click on **Current Time**.

The time and date set in “Current Time” is used for the time stamp in the event log

Event Log: Shows the last 200 events

Clear: Clears the event log when clicked

Download: Downloads the Event log in text format when clicked. This allows the event log to be sent to the factory or technician if requested during troubleshooting.

Program Page

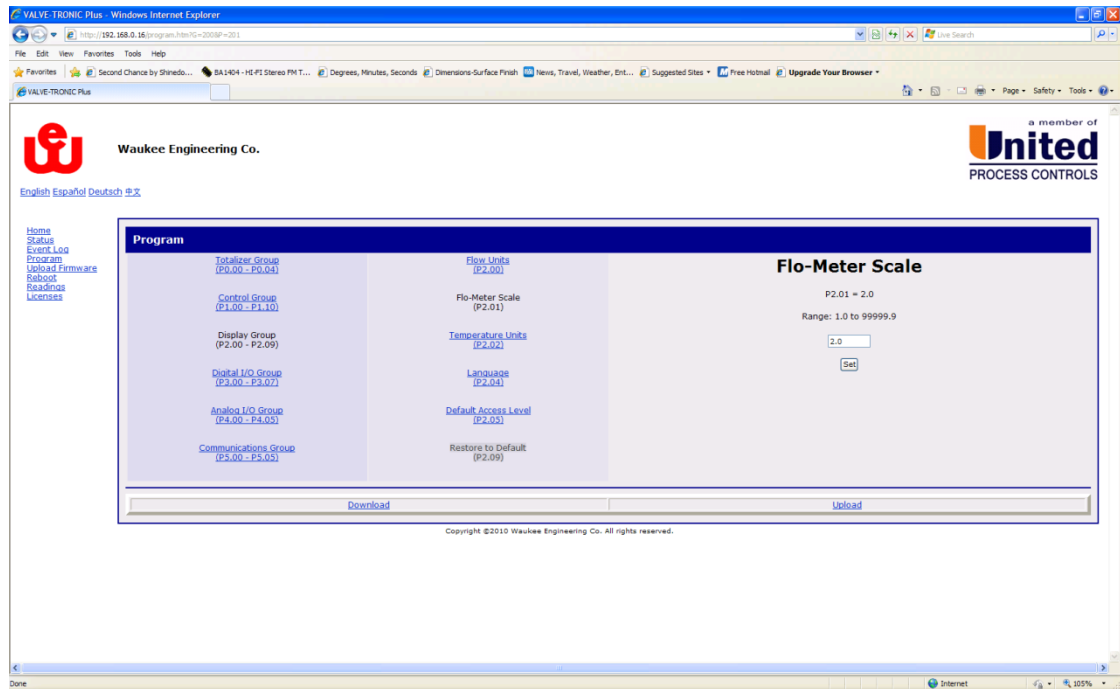

Parameter Group: Shows a list of parameter groups

Parameter Sub-Group: Shows a list of parameters within a group

Parameter Setting: Shows the currently selected parameter value. Selecting the data entry field will allow a new value to be entered. Once desired value is entered click **Set**.

Download: Downloads the configuration file to you PC.

Upload: Allows you to upload a configuration file into the Valve-Tronic.

Click **Browse** to find a configuration file and then click **Upload** to send the configuration file to the *Valve-Tronic Plus*.

Upload Firmware Page

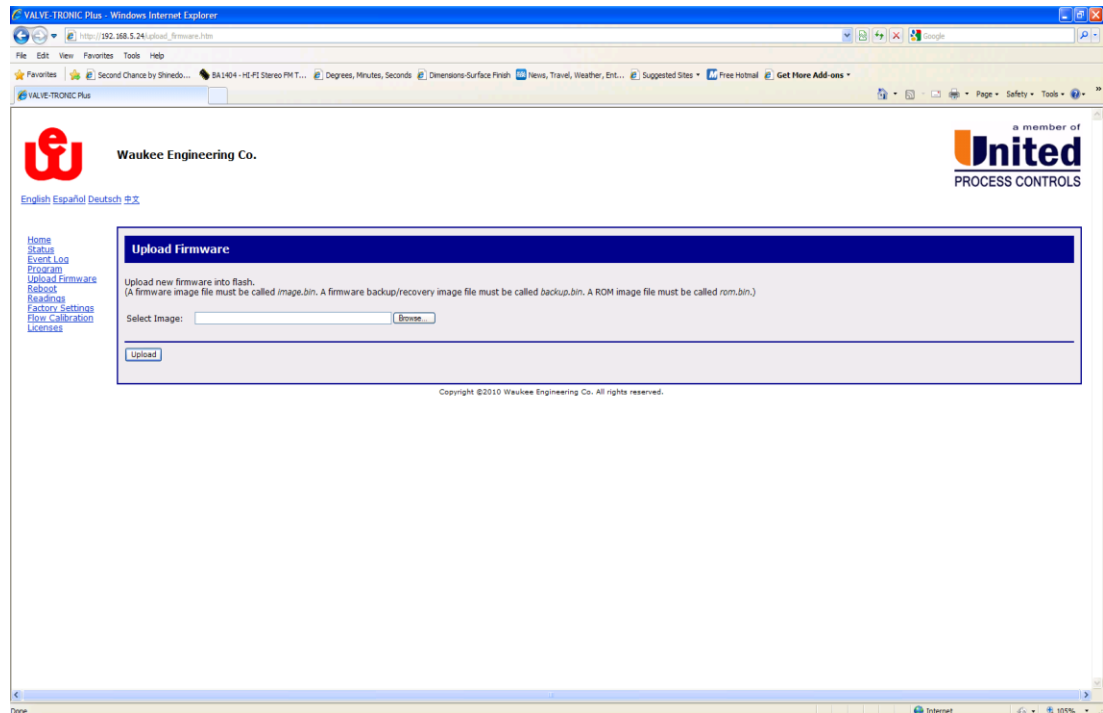

To upload a new firmware into the *Valve-Tronic Plus*. Click on **Browse** to locate the image file and then click on **Upload** to upload the firmware to the *Valve-Tronic Plus*.



WARNING: DO NOT remove power from the *Valve-Tronic Plus* or PC during firmware update. Failure to maintain power during update may result in the unit becoming inoperable and require sending it back to the factory for repair.

Reboot Page

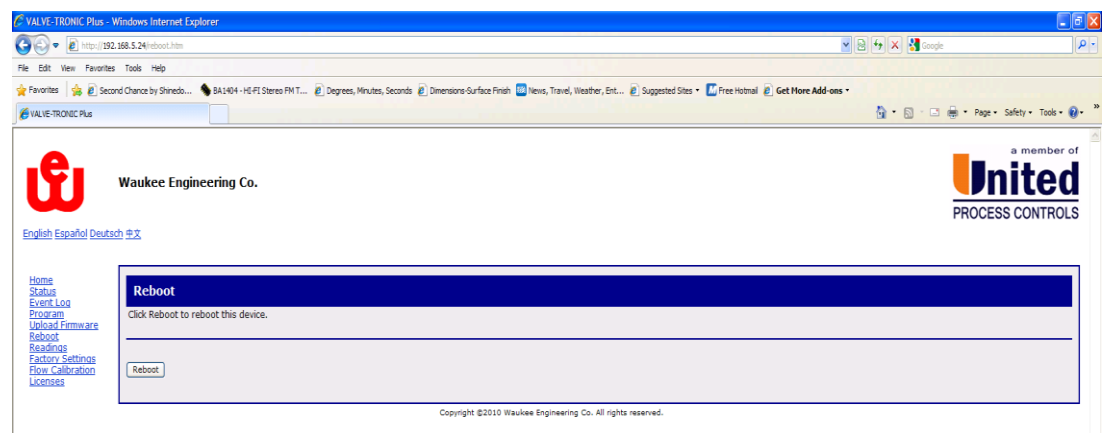

Some parameter changes may require a reboot to take effect, but clicking on **Reboot** it will force the unit to reboot.

11. MODBUS COMMUNICATIONS

11.1 MODBUS TCP

MODBUS TCP is used for TCP/IP communications between client and server devices on an Ethernet network. The TCP version of MODBUS follows the OSI Network Reference Model. For more information on MODBUS communication visit www.modbus.org

Supported MODBUS Function Codes

The following MODBUS function codes are supported by the *Valve-Tronic Plus*.

MODBUS Function Code	Function
02	Read Input Discretes
03	Read Multiple Registers
04	Read Input Registers
06	Write Single Register
16	Write Multiple Registers

Determining the MODBUS Address

There are typically two ways that most MODBUS addressing conventions allow you to specify a memory location. These are:

- By specifying the MODBUS data type and address
- By specifying a MODBUS address only

If your Server Requires the Data Type and Address

Many MODBUS TCP clients allow you to specify the MODBUS data type and the MODBUS address that corresponds to the unit's memory location. This is the easiest method, but not all packages allow you to do it this way. From the tables on the following pages you would use the Hexadecimal and MODBUS Data Type.

If your Server Requires an Address ONLY

Some MODBUS TCP clients do not allow you to specify the MODBUS data type and address. Instead, you specify an address only. From the tables on the following pages you would use the MODBUS Decimal.

12. CONTROL VALVE MEMORY ADDRESSES

Parameter Memory Addresses					
Parameter	Description	MODBUS Decimal	Hexadecimal	MODBUS Data Type	Data Type
Totalizer Parameters					
P0.00	Totalizer Decimal Point	40002	0x0002	Holding Register	UINT16
P0.01	Totalizer Scale Factor	40003	0x0003	Holding Register	UINT16*1000
P0.02	Totalizer Low Cut Value	40004	0x0004	Holding Register	UINT16
P0.04	Totalizer Power UP Reset	40005	0x0005	Holding Register	UINT16
Control Parameters					
P1.00	Setpoint Source	40006	0x0006	Holding Register	UINT16
P1.01	PID Gain	40007	0x0007	Holding Register	UINT16
P1.02	PID Reset	40008	0x0008	Holding Register	UINT16*100
P1.03	PID Rate	40009	0x0009	Holding Register	UINT16*10
P1.04	PID Filter	40010	0x000A	Holding Register	UINT16*10
P1.05	Dead Band	40011	0x000B	Holding Register	UINT16*10
P1.06	PID Delay	40012	0x000C	Holding Register	UINT16*10
P1.07	Control Mode	40040	0x0028	Holding Register	UINT16
P1.08	Control Range	40041	0x0029	Holding Register	UINT16
P1.09	Control Type	40053	0x0035	Holding Register	UINT16
Display Parameters					
P2.00	Flow Units	40013	0x000D	Holding Register	UINT16
P2.01	Flo-Meter Scale	40014, 40015	0x000E, 0x000F	Holding Register	UINT32*10
P2.02	Temperature Units	40016	0x0010	Holding Register	UINT16
P2.03	Pressure Units	40018	0x0012	Holding Register	UINT16
Digital I/O Parameters					
P3.00	Multi-function Input Terminal (DI1)	40021	0x0015	Holding Register	UINT16
P3.01	Multi-function Output Terminal (DO1)	40022	0x0016	Holding Register	UINT16
P3.02	Multi-function Output Terminal (DO2)	40023	0x0017	Holding Register	UINT16
P3.03	Multi-function Output Terminal (DO3)	40024	0x0018	Holding Register	UINT16
P3.04	High Flow Alarm Setpoint	40025, 40026	0x0019, 0x001A	Holding Register	INT32
P3.05	Low Flow Alarm Setpoint	40027, 40028	0x001B, 0x001C	Holding Register	INT32
P3.06	Totalizer Alarm Setpoint	40029, 40030	0x001D, 0x001D	Holding Register	INT32
P3.07	Digital Output Logic	40052	0x0034	Holding Register	UINT16
Analog I/O Parameters					
P4.00	Loss of Control Signal (AI1)	40031	0x001F	Holding Register	UINT16
P4.01	Loss of Sensor Signal	40032	0x0020	Holding Register	UINT16

12.1 Parameter Memory Addresses



The parameters in the following list must not be written to on a continuous basis as to do so will damage the EEPROM greatly reducing its useful life

12.2 Status Addresses

Status Addresses				
Description	MODBUS Decimal	Hexadecimal	MODBUS Data Type	Data Type
Status Monitor 1 (Read Only)	30001	0x0001	Input Register	UINT16
Actual Flow (Read Only)	30017	0x0011	Input Register	UINT16*10
	30033, 30034	0x0021, 0x0022	Input Register	FLOAT32
Total Flow (Read Only)	30018	0x0012	Input Register	UINT16
	30035,30036	0x0023, 0x0024	Input Register	FLOAT32
Flow Feedback (Read Only)	30019	0x0013	Input Register	INT16*10
Setpoint	40001	0x0001	Holding Register	INT16*10
Valve Position (Read Only)	30021	0x0015	Input Register	INT16*10
Pressure Feedback (Read Only)	30022	0x0016	Input Register	INT16*10
Temperature Feedback (Read Only)	30023	0x0017	Input Register	INT16*10
Digital Input (Read Only)	10001	0x0001	Discrete Input	Binary
Home Switch (Read Only)	10002	0x0002	Discrete Input	Binary
Alarm 1 (Read Only)	10003	0x0003	Discrete Input	Binary
Alarm 2 (Read Only)	10004	0x0004	Discrete Input	Binary
Alarm 3 (Read Only)	10005	0x0005	Discrete Input	Binary
Setpoint Mode (Read Only)	10007	0x0007	Discrete Input	Binary

12.3 Status Monitor 1 Error Codes

Status Monitor 1 Error Codes (30001)	
Error	Bit Number
Temperature Feedback Loss	0
Temperature Feedback Over Range	1
Pressure Feedback Loss	2
Pressure Feedback Over Range	3
Control Signal Loss	4
Control Signal Over Range	5
Flow Feedback Signal Loss	6
Flow Feedback Signal Over Range	7
Motor Failure	8
Closed Valve	9
Home Cal OK?	10
Home Switch Failure	11
Comm Time-Out	12
Overheat	13

12.4 Memory Location and Data Types

Generally you have many different types of information to process. This includes input device status, output device status, etc. It is important to understand how the system represents and stores the various types of data. For example, you need to know how the system identifies input points, output

points and data words. The following paragraphs discuss the various memory types used in *Valve-Tronic Plus's*.

Data Type Check

If you are unsure of the format of a data type you can read the registers as shown in the below table and they should report the values as shown

Data Type Check Registers				
Description	MODBUS Decimal	Hexadecimal	MODBUS Data Type	Register Value
INT32 Check	30100, 30101	0x0064, 0x0065	Input Register	0x12345678 = 305419896
Float32 Check	30103, 30104	0x0067, 0x0068	Input Register	123.321
INT16 Check	30106	0x006A	Input Register	0X1234 = 4660

Discrete and Word Locations

As you examine the different memory types, you'll notice two types of memory in the *Valve-Tronic Plus*, discrete and word memory. Discrete memory is one bit that can be either a 1 or a 0. Word memory is referred to as V-memory (variable) and is a 16-bit location normally used to manipulate data/numbers, store data/numbers, etc.

Word Memory

The word memory area is for data. The *Valve-Tronic Plus* utilizes a couple of different data types. Some types of words are shown with a multiplier; the value has been multiplied before put into its register. To interpret the value correctly, the value that is read from the register must be divided by this same amount. See Example 1 below.

Example 1: If you would like to know the “Actual Flow Rate”, which is MODBUS Address 30017 and has a data type of UINT16*10. So if this register contains the value 523 the actual flow would be 52.3 (523÷10)

For a higher degree of accuracy some values are stored in more than one register to provide 32 bits or 2 words. The least significant word is stored in the register with the lower number (little-endian word order) but the bytes within the word are stored with the most significant byte first (big-endian byte order) Both words must be written at the same time. See Example 2 on how to write a value with two words.

Example 2: If you would like to set the “High Flow Alarm Setpoint” which is MODBUS Address 40025 and 40026 and has a data type of UINT32 and you want to send a setpoint of 500.5, you would multiply the value by 10 (500.5 x10 = 5005) So you would send a value of 5005 to register 40025 and 0 to register 40026

Status Monitor 1

The Status Monitor 1 is a 16 bit word located at MODBUS address 30001 and it is a bit field, so when a bit is set to logic 1 it indicates that error condition exists.

Example 3: If you look at the table below you will see the value contained in the register is 000010000010000 which shows bit # 4 and #11 are active so the Valve-Tronic is reporting an error of “Home Switch Failure” and “Control Signal Loss” if the register contained all zero’s that would indicate that no error conditions exist.

Value	0	0	0	0	1	0	0	0	0	0	0	1	0	0	0	0
Bit #	15	14	13	12	11	10	9	8	7	6	5	4	3	2	1	0
N/A	N/A	Overheat	Comm Time-Out	Home Switch Failure	Home Cal OK?	Closed Valve	Motor Failure	Flow Feedback Signal Over Range	Flow Feedback Signal Loss	Control Signal Over Range	Control Signal Loss	Press. Feedback Over Range	Pressure Feedback Loss	Temp Feedback Over Range	Temperature Feedback Loss	

13. TROUBLESHOOTING

13.1 Error Messages

The Control Valve has a comprehensive diagnostic system that includes several different error messages. The error messages are displayed on the digital keypad LCD display.

Error Messages	
Error Name/Description	Corrective Actions
TEMP FBACK LOSS Temperature Feedback Signal Loss	1. Check all connections to Temp. /Pressure Sensor 2. Replace Temp/Pressure Sensor
TEMP FBACK OVER Temperature Feedback Signal Over Range	1. Check all connections to Temp. /Pressure Sensor 2. Replace Temp/Pressure Sensor
PRES FBACK LOSS Pressure Feedback Signal Loss	1. Check all connections to Temp. /Pressure Sensor 2. Replace Temp/Pressure Sensor
PRES FBACK OVER Pressure Feedback Signal Over Range	1. Check all connections to Temp. /Pressure Sensor 2. Replace Temp/Pressure Sensor
CONT SIGNAL LOSS Loss of Control Signal	1. Check all connections to Controller 2. Check if control signal is within 4-20mA range
CONT SIGNAL OVER Control Signal above 21mA	1. Check all connections to Controller 2. Check if control signal is within 4-20mA range
FLOW FBACK LOSS Flow Sensor Feedback Loss	1. Check and verify all connections to the Flo-Tronic Sensor.
FLOW FBACK OVER Flow Sensor Feedback signal out of range	1. Check and verify all connections to the Flo-Tronic Sensor.

Error Messages (Continued)	
Error Name/Description	Corrective Actions
MOTOR FAILURE	1. Try to free up motor using Manual override valve located on top of unit. 2. Contact Waukee Engineering for assistance
Internal Stepper Motor Failure	
CLOSED VALVE	1. If Digital Input (DI1) is not being used set P3.0 to "00: None" 2. Check and verify all connections to controller
Closed Valve contacts open	
HOME CAL OK?	1. Press DISP/ENTER key to OK calibration.
Unit needs to drive the valve closed to set zero valve position	
HOME SW FAILURE	1. Home Switch out of adjustment, contact Waukee Engineering for assistance
Home Switch Failure	
COMM TIME-OUT	1. Verify and check all communications wiring 2. Verify that communication settings for Controller and Control valve are the same.
Communications Time-Out	
OVER HEAT	1. Shield Unit from any Heat Sources
Unit is too Hot	

14. APPENDIX “A” - DRAWINGS

On demand

Reach us at www.group-upc.com

United Process Controls brings together leading brands to the heat treating industry including Waukee Engineering, Furnace Control, Marathon Monitors and Process-Electronic.

We provide prime control solutions through our worldwide sales and services network with easy-to-access local support.

UNITED PROCESS CONTROLS INC.
WAUKEE PRODUCTS PLANT
5600 West Florist Avenue, Milwaukee, WI 53218, U.S.A.

Phone: +1-414-462-8200 Fax: +1-414-462-7022
E-mail: waukee.sales@group-upc.com

