

User Manual

Pressure • Temperature • Humidity • Air Velocity • Airflow • Sound level

KIRAY 100 Infrared thermometer

New
CE



Infrared thermometer **KIRAY 100** equipped with a dual laser sighting is a key instrument to diagnose, inspect and check any temperature, with the advantage of using a “no-contact” technology. You can measure safely surfaces temperatures of warm and dangerous objects or objects with uneasy access. It's the perfect tool for measurements in a house, a garage, a workshop, a kitchen, etc...

■ Technical features

- Spectral response.....8 - 14 μ m
- Optical.....D.S : 20:1 (13 mm at 260 mm)
- Temperature range.....From -50 to +800°C
- Accuracy*.....From -50 à +20°C : $\pm 2.5^\circ\text{C}$
From +20 to +300°C : $\pm 1\%$ of reading $\pm 1^\circ\text{C}$
From +300°C to +800°C : $\pm 1.5\%$
- Infrared repeatability.....From -50 to +20°C : $\pm 1.3^\circ\text{C}$
From -20 to +800°C : $\pm 0.5\%$ or $\pm 0.5^\circ\text{C}$
- Display resolution.....0.1°C
- Response time.....150 ms
- Emissivity.....Adjustable from 0.10 to 1.0 (pre-set at 0.95)
- Over range indication.....Display indication : « ---- »
- Dual laser sighting.....Wave length : from 630 nm to 670 nm
Output < 1mW, Class 2 (II)
- Positive or negative temperature indication.....Automatic (no indication for a positive temperature)
(-) sign for a negative temperature
- Display.....4 digits with LCD backlight display
- Auto-extinction.....Automatic after 7 seconds of inactivity
- High/low alarm.....Flashing signal on display and beep signal with adjustable thresholds
- Power supply.....Alkaline 9V battery
- Autonomy.....105 h (inactive laser and backlight)
20 h (active laser and backlight)
- Use temperature.....From 0 to +50°C
- Storage temperature.....From -10°C to +60°C
- Relative humidity.....From 10 to 90%RH in operating mode
and > 80%RH in storage
- Dimensions.....145 x 95 x 40 mm
- Weight.....180 g (included battery)

■ Distance from the target

Distance	254	260	508	mm
Diameter	12.7	13	25.4	mm

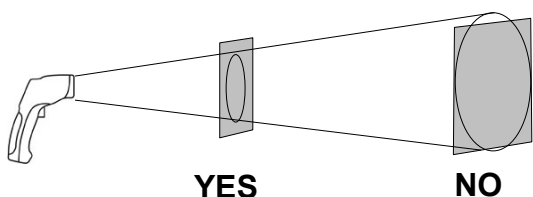
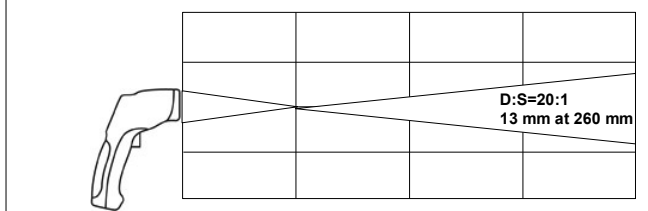

Make sure that the target is larger than the size of the laser sighting.

[Kimo KIRAY 100 Infrared Thermometer](#)

KIRAY 100 instruments description



Modes flow chart

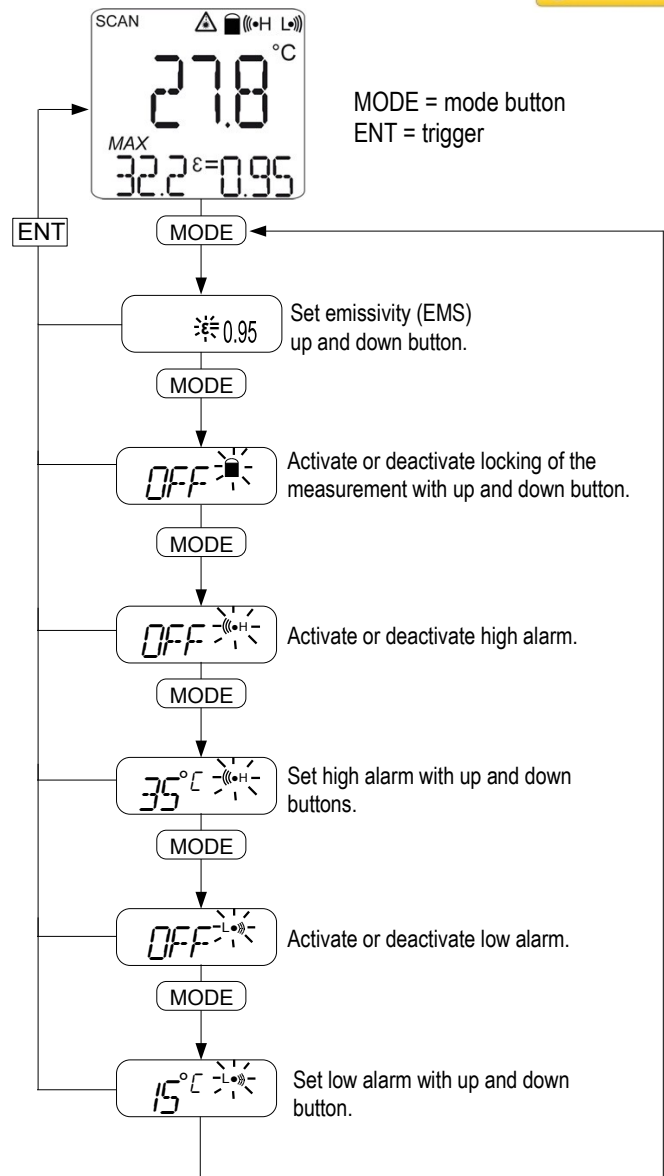

KIRAY 100 instrument buttons



- 1 – Up button. It allows to increment emissivity and thresholds of high and low alarm. This button also allows, in measurement mode, to activate or deactivate the laser.
- 2 – Down button. It allows to decrement emissivity and thresholds of high and low alarm. This button also allows, in measurement mode, to activate or deactivate the backlight.
- 3 – Mode button. It allows to navigate trough the modes (emissivity, lock, high and low alarms).

Display

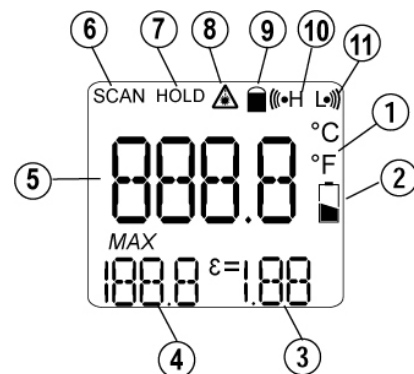

- 1 – Unit of measurement (°C / °F)
- 2 – Low battery indicator
- 3 – Emissivity value = 0.95 (pre-set)
- 4 – Max. temperature indicator
- 5 – Temperature value
- 6 – Current measurement indicator
- 7 – HOLD indicator (fixed measurement)
- 8 – Laser operation indicator
- 9 – Lock Indicator (continuous measurements)
- 10 – High alarm symbol (fixed : alarm is activated ; Flashing + beep : alarm threshold exceeded)
- 11 – Low alarm symbol (fixed : alarm is activated ; Flashing + beep : alarm threshold exceeded)

Settings before taking measurements

Before measuring temperature, it is recommended to set the technical unit : °C or °F

To set this parameter, open the battery door by pushing on both sides of the trigger. It is not necessary to disconnect the battery to make this setting.

• Set the technical unit

Set the selector unit to °C or °F with a screwdriver..

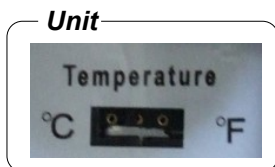

Operating mode

- Press **ENT** trigger to turn on the instrument. The backlighted screen, indicating the temperature, and the laser turn on.
- Keep **ENT** pressed. Place the laser sighting at the center of the area to be measured.
- Release **ENT**.
- Read the displayed temperature. (Display stays on for 7 seconds after the last manipulation).
- **HOLD** appears at the top left of the screen ; measurement stays displayed.
- Press **UP** button to activate or deactivate the laser ;
- Press **DOWN** button to activate or deactivate the backlight.

Command buttons

ENT Trigger

- Turning on the device.
- **ENT** pressed : activation of the laser sighting and temperature measurement.
- **ENT** released : display is on HOLD (HOLD fixed), and gives the last measurement. Display stays on for 7 seconds. If no buttons are activated and if continuous measurement is inactivated, the instrument turn off after 7 seconds.

MODE Mode button

Allows to define types of desired measurement : emissivity, lock, high alarm, low alarm by pressing as many time on this button.

- **EMS** : when **KIRAY100** instrument is turned on, press **MODE** button, **ε** flashes. Set emissivity by pressing on **UP** button to increment it or **DOWN** button to decrement it. By default, emissivity is set on 0.95.

To back to measurement mode, press **ENT** button ; press **MODE** button to go to next mode.

- **Lock** : when **KIRAY100** instrument is turned on, press **MODE** button twice, the lock indicator at the top of the screen flashes and **OFF** is displayed. Press **UP** or **DOWN** button to put the lock **ON**. Press **MODE** button to go to next mode, or press **once ENT** button : **KIRAY100** instrument takes continuous measurements. To cancel lock mode, press **once ENT** button.

- **High alarm** : when **KIRAY100** instrument is turned on, press **3 times MODE** button to set high alarm. **ON** or **OFF** flashes, press **UP** or **DOWN** button to activate or deactivate it (**ON** or **OFF**). Press **MODE** button, high alarm temperature is displayed and high alarm indicator flashes, press **UP** button to increment it or **DOWN** button to decrement it.

To return to measurement mode, press **ENT** button ; press **MODE** button to go to next mode.

- **Low alarm** : when **KIRAY100** instrument is turned on, press **5 times MODE** button to set low alarm. **ON** or **OFF** flashes, press **UP** or **DOWN** button to activate or deactivate it (**ON** or **OFF**).

Press **MODE** button, low alarm temperature is displayed and low alarm indicator flashes, press **UP** button to increment it or **DOWN** button to decrement it.

To return to measurement mode, press **ENT** button ; press **MODE** button to go to next mode.

Emissivity

Emissivity is a term used to describe the energy-emitting characteristics of materials.

Most (90% of typical applications) organic materials and painted or oxidized surfaces have an emissivity of 0.95 (pre-set in the unit). Inaccurate readings will result from measuring shiny or polished metal surfaces. To compensate; cover the surface to be measured with masking tape or flat black paint. Allow time for the tape to reach the same temperature as the material underneath it. Measure the temperature of the tape or painted surface.

See table below for values of emissivity of specific materials :

Aluminium	0.30	Ice	0.98
Asbestos	0.95	Iron	0.70
Asphalt	0.95	Lead	0.50
Basalt	0.70	Limestone	0.98
Brass	0.50	Oil	0.94
Brick	0.90	Paint	0.93
Carbon	0.85	Paper	0.95
Ceramic	0.95	Plastic	0.95
Concrete	0.95	Rubber	0.95
Copper	0.95	Sand	0.90
Dirt	0.94	Skin	0.98
Frozen food	0.90	Snow	0.90
Hot food	0.93	Steel	0.80
Glass	0.85	Textile	0.94
Water	0.93	Wood	0.94

Important information

For correct measurements :

- Do not take any measurement on metal or shiny or reflective surfaces.
- Do not measure through transparent surfaces such as glass, for example.
- Water vapor, dust, smoke, etc ... may prevent correct measurements because they obstruct the optical of the instrument.
- Make sure that the target is larger than the size of the laser sighting.

To avoid any inconvenience :

- Do not aim directly or indirectly (reflection on reflective surfaces) the laser in the eyes.
- Change the batteries when the indicator blinks.
- Do not use the thermometer around explosive gas, vapor or dust
- Do not leave the device with the lock on (lock at the top right of the screen) because in this configuration, the instrument does not turn off automatically.

To prevent damage on your instrument or equipment please carefully respect these conditions :

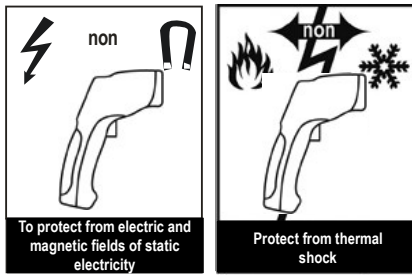

■ CE certification

This device meets with following standards' requirements.

- EN 50081-1 : 1992, Electromagnetic compatibility, Part 1
- EN 50082-1 : 1992, Electromagnetic compatibility, Part 2

■ Maintenance

To install or change the 9V battery, open the part near the trigger and put it in the battery compartment.

■ Accessories

- Case holster with passer-by belt
- User manual

Infrared thermometer, how does it works?

Infrared thermometers can measure the surface temperature of an object. Its optic lens catches the energy emitted and reflected by the object. This energy is collected and focused onto a detector. This information is displayed as temperature. The laser pointer is only used to aim at the target.

