

NI SC Express

NI PXIe-4300 User Manual

Worldwide Technical Support and Product Information

ni.com

National Instruments Corporate Headquarters

11500 North Mopac Expressway Austin, Texas 78759-3504 USA Tel: 512 683 0100

Worldwide Offices

Australia 1800 300 800, Austria 43 662 457990-0, Belgium 32 (0) 2 757 0020, Brazil 55 11 3262 3599,
Canada 800 433 3488, China 86 21 5050 9800, Czech Republic 420 224 235 774, Denmark 45 45 76 26 00,
Finland 358 (0) 9 725 72511, France 01 57 66 24 24, Germany 49 89 7413130, India 91 80 41190000,
Israel 972 3 6393737, Italy 39 02 41309277, Japan 0120-527196, Korea 82 02 3451 3400,
Lebanon 961 (0) 1 33 28 28, Malaysia 1800 887710, Mexico 01 800 010 0793, Netherlands 31 (0) 348 433 466,
New Zealand 0800 553 322, Norway 47 (0) 66 90 76 60, Poland 48 22 328 90 10, Portugal 351 210 311 210,
Russia 7 495 783 6851, Singapore 1800 226 5886, Slovenia 386 3 425 42 00, South Africa 27 0 11 805 8197,
Spain 34 91 640 0085, Sweden 46 (0) 8 587 895 00, Switzerland 41 56 2005151, Taiwan 886 02 2377 2222,
Thailand 662 278 6777, Turkey 90 212 279 3031, United Kingdom 44 (0) 1635 523545

For further support information, refer to the *Technical Support and Professional Services* appendix. To comment on National Instruments documentation, refer to the National Instruments Web site at ni.com/info and enter the Info Code `feedback`.

Important Information

Warranty

The NI PXIe-4300 is warranted against defects in materials and workmanship for a period of one year from the date of shipment, as evidenced by receipts or other documentation. National Instruments will, at its option, repair or replace equipment that proves to be defective during the warranty period. This warranty includes parts and labor.

The media on which you receive National Instruments software are warranted not to fail to execute programming instructions, due to defects in materials and workmanship, for a period of 90 days from date of shipment, as evidenced by receipts or other documentation. National Instruments will, at its option, repair or replace software media that do not execute programming instructions if National Instruments receives notice of such defects during the warranty period. National Instruments does not warrant that the operation of the software shall be uninterrupted or error free.

A Return Material Authorization (RMA) number must be obtained from the factory and clearly marked on the outside of the package before any equipment will be accepted for warranty work. National Instruments will pay the shipping costs of returning to the owner parts which are covered by warranty.

National Instruments believes that the information in this document is accurate. The document has been carefully reviewed for technical accuracy. In the event that technical or typographical errors exist, National Instruments reserves the right to make changes to subsequent editions of this document without prior notice to holders of this edition. The reader should consult National Instruments if errors are suspected. In no event shall National Instruments be liable for any damages arising out of or related to this document or the information contained in it.

EXCEPT AS SPECIFIED HEREIN, NATIONAL INSTRUMENTS MAKES NO WARRANTIES, EXPRESS OR IMPLIED, AND SPECIFICALLY DISCLAIMS ANY WARRANTY OF MERCHANTABILITY OR FITNESS FOR A PARTICULAR PURPOSE. CUSTOMER'S RIGHT TO RECOVER DAMAGES CAUSED BY FAULT OR NEGLIGENCE ON THE PART OF NATIONAL INSTRUMENTS SHALL BE LIMITED TO THE AMOUNT THEREFORE PAID BY THE CUSTOMER. NATIONAL INSTRUMENTS WILL NOT BE LIABLE FOR DAMAGES RESULTING FROM LOSS OF DATA, PROFITS, USE OF PRODUCTS, OR INCIDENTAL OR CONSEQUENTIAL DAMAGES, EVEN IF ADVISED OF THE POSSIBILITY THEREOF. This limitation of the liability of National Instruments will apply regardless of the form of action, whether in contract or tort, including negligence. Any action against National Instruments must be brought within one year after the cause of action accrues. National Instruments shall not be liable for any delay in performance due to causes beyond its reasonable control. The warranty provided herein does not cover damages, defects, malfunctions, or service failures caused by owner's failure to follow the National Instruments installation, operation, or maintenance instructions; owner's modification of the product; owner's abuse, misuse, or negligent acts; and power failure or surges, fire, flood, accident, actions of third parties, or other events outside reasonable control.

Copyright

Under the copyright laws, this publication may not be reproduced or transmitted in any form, electronic or mechanical, including photocopying, recording, storing in an information retrieval system, or translating, in whole or in part, without the prior written consent of National Instruments Corporation.

National Instruments respects the intellectual property of others, and we ask our users to do the same. NI software is protected by copyright and other intellectual property laws. Where NI software may be used to reproduce software or other materials belonging to others, you may use NI software only to reproduce materials that you may reproduce in accordance with the terms of any applicable license or other legal restriction.

Trademarks

CVI, LabVIEW, National Instruments, NI, ni.com, the National Instruments corporate logo, and the Eagle logo are trademarks of National Instruments Corporation. Refer to the *Trademark Information* at ni.com/trademarks for other National Instruments trademarks.

The mark LabWindows is used under a license from Microsoft Corporation. Windows is a registered trademark of Microsoft Corporation in the United States and other countries. Other product and company names mentioned herein are trademarks or trade names of their respective companies.

Members of the National Instruments Alliance Partner Program are business entities independent from National Instruments and have no agency, partnership, or joint-venture relationship with National Instruments.

Patents

For patents covering National Instruments products/technology, refer to the appropriate location: **Help»Patents** in your software, the `patents.txt` file on your media, or the *National Instruments Patent Notice* at ni.com/patents.

WARNING REGARDING USE OF NATIONAL INSTRUMENTS PRODUCTS

(1) NATIONAL INSTRUMENTS PRODUCTS ARE NOT DESIGNED WITH COMPONENTS AND TESTING FOR A LEVEL OF RELIABILITY SUITABLE FOR USE IN OR IN CONNECTION WITH SURGICAL IMPLANTS OR AS CRITICAL COMPONENTS IN ANY LIFE SUPPORT SYSTEMS WHOSE FAILURE TO PERFORM CAN REASONABLY BE EXPECTED TO CAUSE SIGNIFICANT INJURY TO A HUMAN.

(2) IN ANY APPLICATION, INCLUDING THE ABOVE, RELIABILITY OF OPERATION OF THE SOFTWARE PRODUCTS CAN BE IMPAIRED BY ADVERSE FACTORS, INCLUDING BUT NOT LIMITED TO FLUCTUATIONS IN ELECTRICAL POWER SUPPLY, COMPUTER HARDWARE MALFUNCTIONS, COMPUTER OPERATING SYSTEM SOFTWARE FITNESS, FITNESS OF COMPILERS AND DEVELOPMENT SOFTWARE USED TO DEVELOP AN APPLICATION, INSTALLATION ERRORS, SOFTWARE AND HARDWARE COMPATIBILITY PROBLEMS, MALFUNCTIONS OR FAILURES OF ELECTRONIC MONITORING OR CONTROL DEVICES, TRANSIENT FAILURES OF ELECTRONIC SYSTEMS (HARDWARE AND/OR SOFTWARE), UNANTICIPATED USES OR MISUSES, OR ERRORS ON THE PART OF THE USER OR APPLICATIONS DESIGNER (ADVERSE FACTORS SUCH AS THESE ARE HEREAFTER COLLECTIVELY TERMED "SYSTEM FAILURES"). ANY APPLICATION WHERE A SYSTEM FAILURE WOULD CREATE A RISK OF HARM TO PROPERTY OR PERSONS (INCLUDING THE RISK OF BODILY INJURY AND DEATH) SHOULD NOT BE RELIANT SOLELY UPON ONE FORM OF ELECTRONIC SYSTEM DUE TO THE RISK OF SYSTEM FAILURE. TO AVOID DAMAGE, INJURY, OR DEATH, THE USER OR APPLICATION DESIGNER MUST TAKE REASONABLY PRUDENT STEPS TO PROTECT AGAINST SYSTEM FAILURES, INCLUDING BUT NOT LIMITED TO BACK-UP OR SHUT DOWN MECHANISMS. BECAUSE EACH END-USER SYSTEM IS CUSTOMIZED AND DIFFERS FROM NATIONAL INSTRUMENTS' TESTING PLATFORMS AND BECAUSE A USER OR APPLICATION DESIGNER MAY USE NATIONAL INSTRUMENTS PRODUCTS IN COMBINATION WITH OTHER PRODUCTS IN A MANNER NOT EVALUATED OR CONTEMPLATED BY NATIONAL INSTRUMENTS, THE USER OR APPLICATION DESIGNER IS ULTIMATELY RESPONSIBLE FOR VERIFYING AND VALIDATING THE SUITABILITY OF NATIONAL INSTRUMENTS PRODUCTS WHENEVER NATIONAL INSTRUMENTS PRODUCTS ARE INCORPORATED IN A SYSTEM OR APPLICATION, INCLUDING, WITHOUT LIMITATION, THE APPROPRIATE DESIGN, PROCESS AND SAFETY LEVEL OF SUCH SYSTEM OR APPLICATION.

Contents

Chapter 1

Getting Started

Installation	1-1
Module Specifications	1-1
Module Accessories and Cables	1-1
Module Self-Calibration	1-1

Chapter 2

Using the NI PXIe-4300

Connecting Signals	2-1
Device Pinout.....	2-2
I/O Connector Signal Description	2-4
NI PXIe-4300 Block Diagram	2-4
Signal Acquisition Considerations.....	2-6
Input Ranges.....	2-6
ADC.....	2-7
Analog Input Data Acquisition Methods.....	2-7
Software-Timed Acquisitions	2-7
Hardware-Timed Acquisitions	2-7
Analog Input Filter	2-8
Gain	2-9
Analog Input Timing Signals	2-9
Aggregate versus Single Channel Sample Rates	2-11
AI Sample Clock Signal.....	2-11
AI Sample Clock Timebase Signal	2-13
AI Start Trigger Signal.....	2-14
AI Reference Trigger Signal	2-15
AI Pause Trigger Signal.....	2-17
Getting Started with AI Applications in Software	2-18
External Reference Clock.....	2-19
10 MHz Reference Clock.....	2-20
Synchronizing Multiple Devices	2-20
Triggering	2-21
Analog Triggering.....	2-21
Digital Input Triggering	2-24
TB-4300/4300B Accessory	2-24
Accessory Auto-Detection	2-25
Isolation.....	2-25

Chapter 3

NI SC Express Considerations

PXI and NI SC Express Clock and Trigger Signals	3-1
PXIe_CLK100	3-1
PXIe_SYNC100.....	3-1
PXI_CLK10	3-1
PXI Triggers.....	3-2
PXI_STAR Trigger	3-2
PXI_STAR Filters.....	3-2
PXIe_DSTAR <A..C>	3-2
Data Transfer Methods	3-3

Appendix A

Technical Support and Professional Services

List of Figures

Figure 2-1.	NI PXIe-4300 AI Source Grounding Diagram	2-1
Figure 2-2.	NI PXIe-4300 Block Diagram	2-5
Figure 2-3.	NI PXIe-4300 PGIA	2-9
Figure 2-4.	Typical Posttriggered DAQ Sequence	2-10
Figure 2-5.	Typical Pretriggered DAQ Sequence.....	2-10
Figure 2-6.	AI Sample Clock and AI Start Trigger	2-13
Figure 2-7.	Retriggerable Analog Input.....	2-14
Figure 2-8.	Reference Trigger Final Buffer.....	2-16
Figure 2-9.	Halt (Internal Clock) and Free Running (External Clock).....	2-17
Figure 2-10.	External Clock Reference	2-19
Figure 2-11.	Synchronization Operation	2-21
Figure 2-12.	Analog Trigger Level.....	2-22
Figure 2-13.	Analog Edge Triggering with Hysteresis on Rising Slope	2-23
Figure 2-14.	Analog Edge Triggering with Hysteresis on Falling Slope	2-23
Figure 2-15.	Window Triggering.....	2-24

List of Tables

Table 2-1.	Front Signal Pin Assignments	2-3
Table 2-2.	I/O Connector Signal Descriptions	2-4
Table 2-3.	NI PXIe-4300 Input Range and Nominal Resolution	2-6
Table 2-4.	Analog Input Rates for NI PXIe-4300 Modules	2-11
Table 2-5.	Clock Signal Sourcing	2-19
Table 3-1.	PXIe_DSTAR Line Descriptions.....	3-3

Getting Started

The NI PXIe-4300 provides eight, simultaneous sampled, analog input channels, each with channel-to-channel and channel-to-earth isolation. The NI PXIe-4300 has a 10 V maximum measurement range that can be expanded to 300 V when using a TB-4300B. Each channel has a 16-bit ADC with three programmable filter settings and four gain settings. Two input PFI lines are available on the module for triggering.

Installation

Refer to the *NI SC Express 4300 Installation Guide and Terminal Block Specifications* for step-by-step software and hardware installation instructions.

Module Specifications

Refer to the *NI PXIe-4300 Specifications* document for module specifications.

Module Accessories and Cables

Refer to the *NI SC Express 4300 Installation Guide and Terminal Block Specifications* document for information about supported accessories and cables.

Module Self-Calibration

Self-calibration measures the onboard reference voltage of the module and adjusts the self-calibration constants to account for any errors caused by short-term fluctuations in the environment.



Note Disconnect all external signals when you self-calibrate a NI PXIe-4300 module.

NI recommends that you self-calibrate the NI PXIe-4300 module after installation and whenever the ambient temperature changes. Self-calibration should be performed after the module has warmed up for the recommended time period. Refer to the *NI PXIe-4300 Specifications* for the module warm-up time and self-calibration conditions.

You can initiate self-calibration using Measurement & Automation Explorer (MAX), by completing the following steps.

1. Launch MAX.
2. Select **My System»Devices and Interfaces»*your module***.
3. Initiate self-calibration using one of the following methods:
 - Click **Self-Calibrate** in the upper right corner of MAX.
 - Right-click the name of the module in the MAX configuration tree and select **Self-Calibrate** from the drop-down menu.



Note You can also programmatically self-calibrate the module with NI-DAQmx, as described in *Device Calibration* in the *NI-DAQmx Help* or the *LabVIEW Help*.

Using the NI PXIe-4300

This chapter describes how to connect AI inputs to the NI PXIe-4300 module. It also provides the front signal pin assignments of the module.

Connecting Signals

Figure 2-1 shows correct and incorrect AI source grounding.

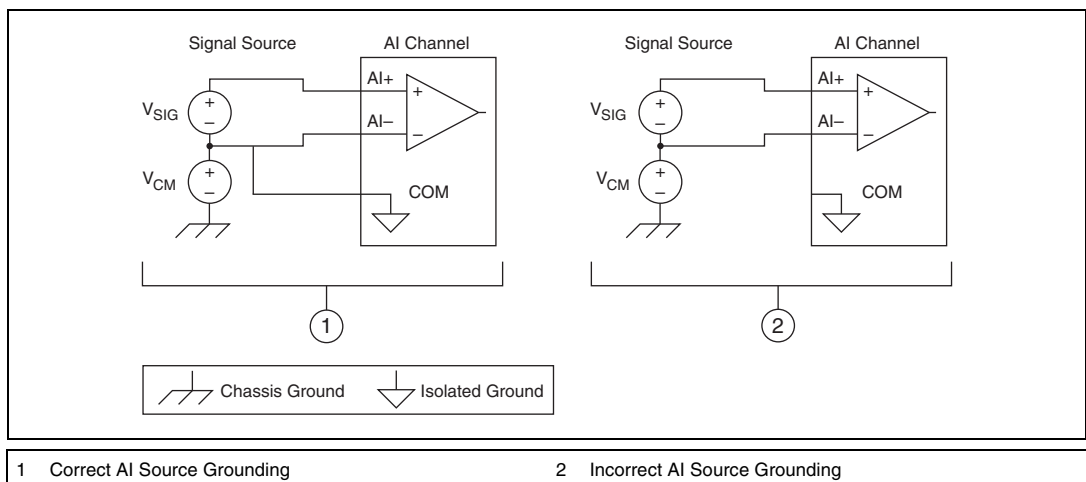

Figure 2-1. NI PXIe-4300 AI Source Grounding Diagram

The COM terminal for each channel must be connected to the reference ground of the AI source. Failure to connect COM results in inaccurate measurements. You can connect the COM terminal directly to the negative terminal of the source as shown in Figure 2-1 or to an isolated ground of the source as long as the working voltage specification of the NI PXIe-4300 is not violated.

For best results wire the AI+ and AI- signals as twisted pairs and use the COM as a shield. The COM connection should be made as close to the source as possible to take advantage of the differential nature of this device.

Refer to the *NI SC Express 4300 Installation Guide and Terminal Block Specifications* document for details about signal terminal locations.

Device Pinout

This is the pinout represented on the front connector of the NI PXIe-4300. Refer to the [I/O Connector Signal Description](#) section for definitions of each signal. Refer to the terminal block installation guide for signal locations on the terminal block.

Table 2-1. Front Signal Pin Assignments

Front Connector Diagram	Pin Number	Column A	Column B	Column C	Channel
<div style="text-align: center;"> Column A B C </div> <p>— is no connection, isolation barrier, RSVD is reserved</p>	32	COM 0	—	AI 0+	0
	31	—	—	AI 0–	
	30	—	—	—	
	29	COM 1	—	AI 1+	1
	28	—	—	AI 1–	
	27	—	—	—	
	26	COM 2	—	AI 2+	2
	25	—	—	AI 2–	
	24	—	—	—	
	23	COM 3	—	AI 3+	3
	22	—	—	AI 3–	
	21	—	—	—	
	20	COM 4	—	AI 4+	4
	19	—	—	AI 4–	
	18	—	—	—	
	17	COM 5	—	AI 5+	5
	16	—	—	AI 5–	
	15	—	—	—	
	14	COM 6	—	AI 6+	6
	13	—	—	AI 6–	
	12	—	—	—	
	11	COM 7	—	AI 7+	7
	10	—	—	AI 7–	
	9	—	—	—	
	8	COM 7	COM 7	COM 7	No Channel
	7	—	PFI 0	PFI 1	
	6	—	—	—	
	5	—	—	—	
	4	—	—	—	
	3	—	—	—	
	2	RSVD	COM 7	RSVD	
	1	RSVD	RSVD	RSVD	

I/O Connector Signal Description

Table 2-2 describes the signals found on the I/O connectors.

Table 2-2. I/O Connector Signal Descriptions

Signal Names	Reference	Direction	Description
COM <0..7>	—	—	Analog Input Isolated Common Ground—These terminals are the reference point for differential analog input measurements.
AI <0..7>+, AI <0..7>-	COM <0..7>	Input	Analog Input Channels 0 to 7—AI + and AI- are the positive and negative inputs of differential analog input.
PFI <0,1>	COM 7	Input	Programmable Function Interface Channels 0 to 1—Each of these terminals can be individually configured as PFI terminals. They can be used to supply a start, reference, or pause trigger, or be used as an external timing source for AI. Note: These channels may only be referenced to channel 7 in order to maintain safety isolation.
RSVD	COM 7	Bi-Directional	These pins are reserved for communication with the accessory.

NI PXIe-4300 Block Diagram

Figure 2-2 shows the NI PXIe-4300 block diagram of the NI PXIe-4300 module.

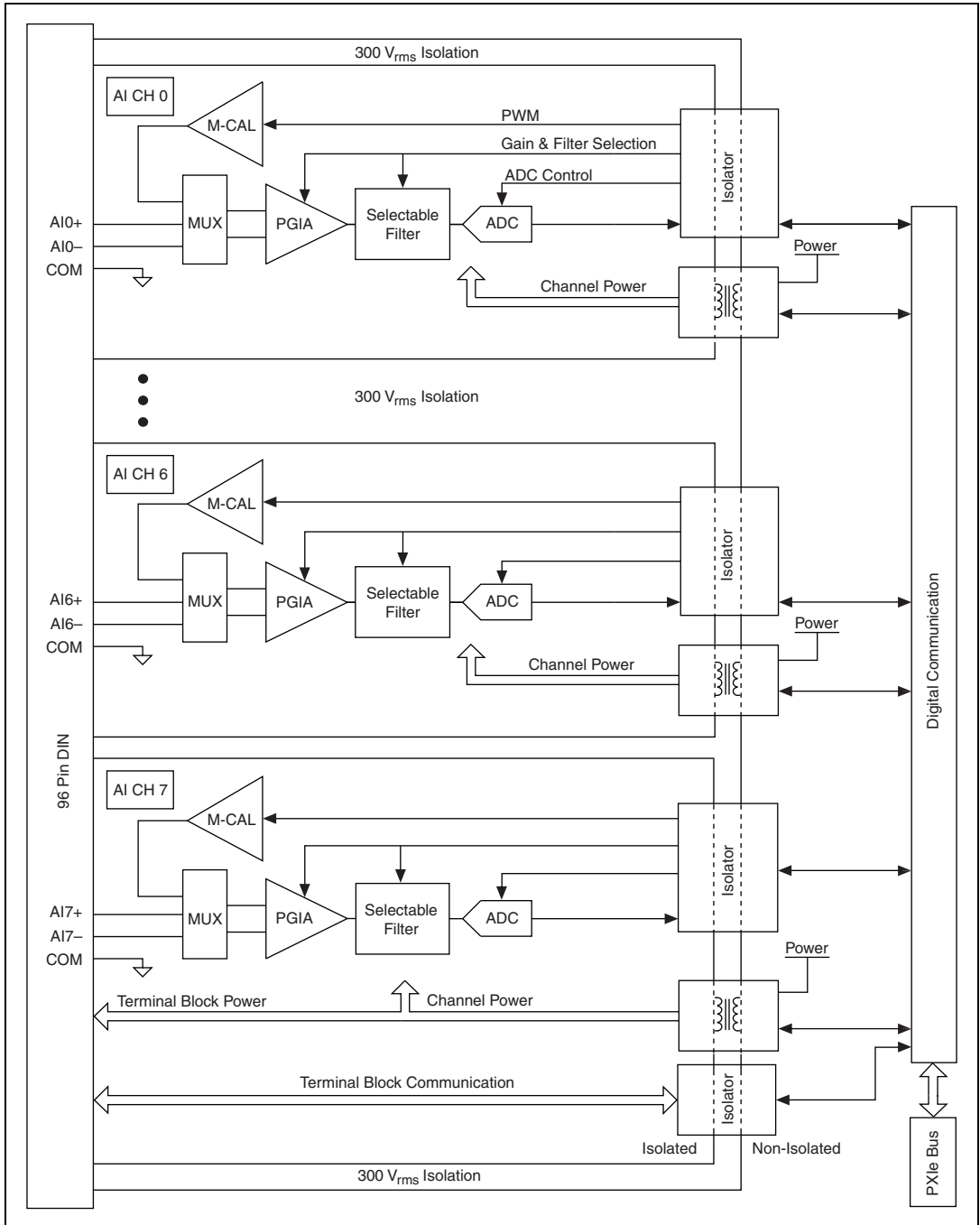

Figure 2-2. NI PXIe-4300 Block Diagram

Signal Acquisition Considerations

This section contains information about signal acquisition concepts including timing, triggering, and synchronization.

Input Ranges

Input range refers to the set of input voltages that an analog input channel can digitize with the specified accuracy. The programmable gain instrumentation amplifier (PGIA) amplifies or attenuates the AI signal depending on the input range. You can individually program the input range of each AI channel on your NI PXIe-4300 module.

The input range affects the resolution of the NI PXIe-4300 module for an AI channel. Resolution refers to the voltage of one ADC code. For example, a 16-bit ADC converts analog inputs into one of 65,536 ($= 2^{16}$) codes—that is, one of 65,536 possible digital values. These values are spread fairly evenly across the input range. So, for an input range of -10 V to 10 V , the voltage of each code of a 16-bit ADC is:

$$\frac{10\text{ V} - (-10\text{ V})}{2^{16}} = 305\text{ }\mu\text{V}$$

Choose an input range that matches the expected input range of your signal. A large input range can accommodate a large signal variation, but reduces the voltage resolution. Choosing a smaller input range improves the voltage resolution, but may result in the input signal going out of range.



Note The NI PXIe-4300 module uses a calibration method that requires codes (typically about 5% of the codes) outside of the specified range. This calibration method improves absolute accuracy, but it decreases the nominal resolution of input ranges by about 5% over what the formula shown above would indicate.

Table 2-3 shows the input ranges and resolutions supported by the NI PXIe-4300 module.

Table 2-3. NI PXIe-4300 Input Range and Nominal Resolution

Input Range	Nominal Resolution Assuming 5% Over Range
-10 V to 10 V	$320\text{ }\mu\text{V}$
-5 V to 5 V	$160\text{ }\mu\text{V}$
-2 V to 2 V	$64\text{ }\mu\text{V}$
-1 V to 1 V	$32\text{ }\mu\text{V}$

ADC

The analog-to-digital converter (ADC) digitizes the AI signal by converting the analog voltage into a digital number. The NI PXIe-4300 module has 8 ADCs. Multiplexers (mux) are used to select filter settings and to select external or internal sources for calibration.

Settling time refers to the time it takes the PGIA to amplify the input signal to the desired accuracy before it is sampled by the ADC.

The PGIA can amplify or attenuate an AI signal to ensure that you use the maximum resolution of the ADC.

Analog Input Data Acquisition Methods

When performing analog input measurements, you can either perform software-timed or hardware-timed acquisitions.

Software-Timed Acquisitions

With a software-timed acquisition, software controls the rate of the acquisition. Software sends a separate command to the hardware to initiate each ADC conversion. In NI-DAQmx, software-timed acquisitions are referred to as having on-demand timing. Software-timed acquisitions are also referred to as immediate or static acquisitions and are typically used for reading a single sample of data.

Hardware-Timed Acquisitions

With hardware-timed acquisitions, a digital hardware signal (AI Sample Clock) controls the rate of the acquisition. This signal can be generated internally on your device or provided externally.

Hardware-timed acquisitions have several advantages over software-timed acquisitions:

- The time between samples can be much shorter.
- The timing between samples is deterministic.
- Hardware-timed acquisitions can use hardware triggering.

Hardware-timed operations can be buffered or hardware-timed single point (HWTSP). A buffer is a temporary storage in computer memory for to-be-transferred samples.

- **Buffered**—In a buffered acquisition, data is moved from the onboard FIFO memory of the DAQ device to a PC buffer using DMA before it is transferred to application memory. Buffered acquisitions typically allow for much faster transfer rates than HWTSP acquisitions because data is moved in large blocks, rather than one point at a time.

One property of buffered I/O operations is the sample mode. The sample mode can be either finite or continuous:

- **Finite sample mode acquisition** refers to the acquisition of a specific, predetermined number of data samples. Once the specified number of samples has been read in, the acquisition stops. If you use a reference trigger, you must use finite sample mode.
- **Continuous acquisition** refers to the acquisition of an unspecified number of samples. Instead of acquiring a set number of data samples and stopping, a continuous acquisition continues until you stop the operation. Continuous acquisition is also referred to as double-buffered or circular-buffered acquisition.

If data cannot be transferred across the bus fast enough, the FIFO becomes full. New acquisitions overwrite data in the FIFO before it can be transferred to host memory. The device generates an error in this case. With continuous operations, if the application program does not read data out of the PC buffer fast enough to keep up with the data transfer, the buffer could reach an overflow condition, causing an error to be generated.

- **Hardware-timed single point (HWTSP)**—Typically, HWTSP operations are used to read single samples at known time intervals. While buffered operations are optimized for high throughput, HWTSP operations are optimized for low latency and low jitter. In addition, HWTSP can notify software if it falls behind hardware. These features make HWTSP ideal for real time control applications. HWTSP operations, in conjunction with the wait for next sample clock function, provide tight synchronization between the software layer and the hardware layer. Refer to the NI Developer Zone document, NI-DAQmx Hardware-Timed Single Point Lateness Checking, for more information. To access this document, go to ni.com/info and enter the Info Code `daqhwtsp`.

Analog Input Filter

The NI PXIe-4300 has selectable filter settings per channel. Each channel can independently be set to one of the 3 available lowpass filter settings: 10 kHz, 100 kHz, and Disable. The 10 kHz and 100 kHz filters are 2-pole Butterworth filters, and their designation refers to the –3 dB cut-off frequency. The *Disable* setting bypasses the filters and allows measurements in the full bandwidth of the NI PXIe-4300.

Gain

The NI PXIe-4300 module implements the different analog input COM-reference settings by routing different signals to the PGIA. The PGIA is a differential amplifier so it amplifies (or attenuates) the difference in voltage between its two inputs. The PGIA drives the ADC with this amplified voltage. The amount of amplification (the gain), is determined by the analog input range, as shown in Figure 2-3.



Note Time and temperature can introduce gain and offset AI errors at runtime. You can minimize these errors by self-calibrating the module.

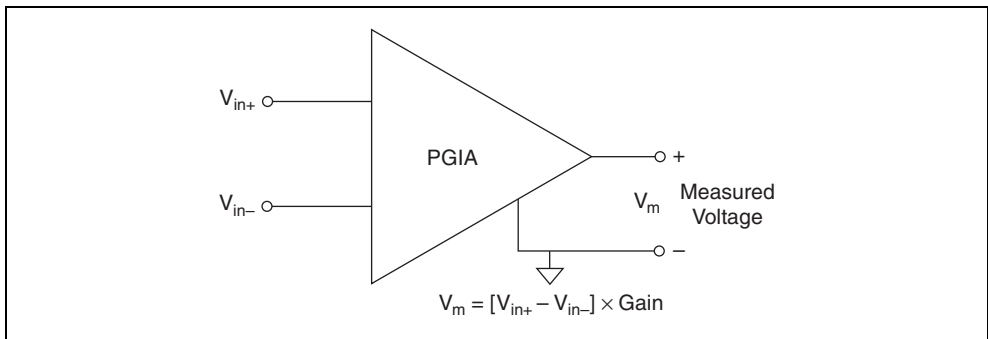

Figure 2-3. NI PXIe-4300 PGIA

Analog Input Timing Signals

In order to provide all of the timing functionality described throughout this section, NI PXIe-4300 modules have a flexible timing engine.

NI PXIe-4300 modules use AI Sample Clock (ai/SampleClock) to perform simultaneous sampling on all active analog channels. Since there is one ADC per channel, AI Sample Clock controls the sample period on all the channels in the task.

An acquisition with posttrigger data allows you to view data that is acquired after a trigger event is received. A typical posttrigger DAQ sequence is shown in Figure 2-4. The sample counter is loaded with the specified number of posttrigger samples, in this example, five. The value decrements with each pulse on AI Sample Clock, until the value reaches zero and all desired samples have been acquired.

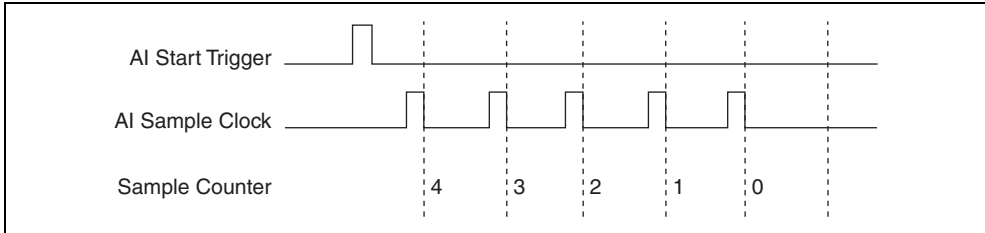

Figure 2-4. Typical Posttriggered DAQ Sequence

An acquisition with pretrigger data allows you to view data that is acquired before the trigger of interest, in addition to data acquired after the trigger. Figure 2-5 shows a typical pretrigger DAQ sequence. The AI Start Trigger signal (ai/StartTrigger) can be either a hardware or software signal. If AI Start Trigger is set up to be a software start trigger, an output pulse appears on the ai/StartTrigger line when the acquisition begins. When the AI Start Trigger pulse occurs, the sample counter is loaded with the number of pretrigger samples, in this example, four. The value decrements with each pulse on AI Sample Clock, until the value reaches zero. The sample counter is then loaded with the number of posttrigger samples, in this example, three.

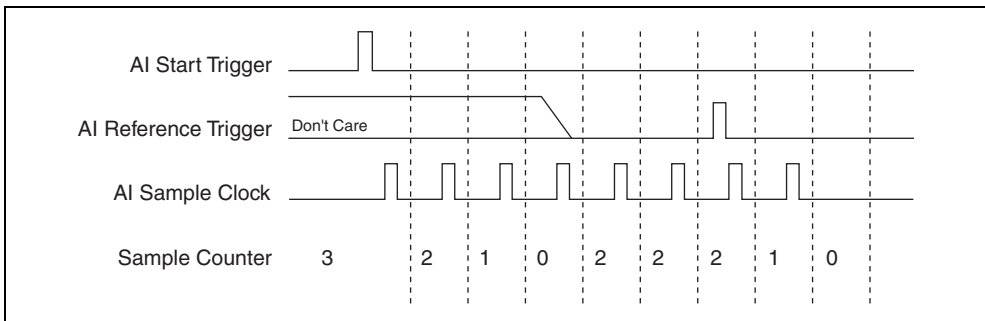

Figure 2-5. Typical Pretriggered DAQ Sequence

If an AI Reference Trigger (ai/ReferenceTrigger) pulse occurs before the specified number of pretrigger samples are acquired, the trigger pulse is ignored. Otherwise, when the AI Reference Trigger pulse occurs, the sample counter value decrements until the specified number of posttrigger samples have been acquired. For more information about start and reference triggers, refer to the [Analog Triggering](#) section.

NI PXIe-4300 modules feature the following analog input timing signals:

- AI Sample Clock Signal
- AI Sample Clock Timebase Signal
- AI Start Trigger Signal
- AI Reference Trigger Signal
- AI Pause Trigger Signal

Aggregate versus Single Channel Sample Rates

NI PXIe-4300 modules have one ADC per channel so the single channel maximum sample rate can be achieved on each channel. The maximum single channel rate is the fastest you can acquire data on the device from a single or multiple channels and still achieve accurate results.

The total aggregate determines the maximum bus bandwidth used by the device. The total aggregate sample rate is the product of the maximum sample rate for a single channel multiplied by the number of AI channels that the device support.

Table 2-4 shows the single channels and total aggregate rates for NI PXIe-4300 modules.

Table 2-4. Analog Input Rates for NI PXIe-4300 Modules

Analog Input Rate	
Single Channel	Total Aggregate
250 kS/s	2 MS/s

AI Sample Clock Signal

Use the AI Sample Clock (ai/SampleClock) signal to initiate a set of measurements. Your NI PXIe-4300 module samples the AI signals of every channel in the task once for every AI Sample Clock. A measurement acquisition consists of one or more samples.

You can specify an internal or external source for AI Sample Clock. You also can specify whether the measurement sample begins on the rising edge or falling edge of AI Sample Clock.

Using an Internal Source

One of the following internal signals can drive AI Sample Clock:

- AI Sample Clock Timebase (divided down).
- A pulse initiated by host software that does a software, *on demand*, acquisition.

A programmable internal counter divides down the sample clock timebase.

Several other internal signals can be routed to AI Sample Clock through internal routes. Refer to *Device Routing in MAX* in the *NI-DAQmx Help* or the *LabVIEW Help* for more information.

Using an External Source

Use one of the following external signals as the source of AI Sample Clock:

- PFI <0, 1>
- PXI_Trig <0..7>
- PXI_STAR
- PXIe_DSTAR <A, B>

Routing AI Sample Clock Signal to an Output Terminal

You can route AI Sample Clock out to any PXI_Trig <0..7>, or PXIe_DSTAR terminal. This pulse is always active high.

All PFI terminals are configured as inputs by default.

Other Timing Requirements

Your DAQ device only acquires data during an acquisition. The device ignores AI Sample Clock when a measurement acquisition is not in progress. During a measurement acquisition, you can cause your DAQ device to ignore AI Sample Clock using the AI Pause Trigger signal.

A counter/timing engine on your device internally generates AI Sample Clock unless you select some external source. AI Start Trigger starts this counter and either software or hardware can stop it once a finite acquisition completes. When using an internally generated AI Sample Clock, you also can specify a configurable delay from AI Start Trigger to the first AI Sample Clock pulse. By default, this delay is set to two ticks of the AI Sample Clock Timebase signal.

Figure 2-6 shows the relationship of AI Sample Clock to AI Start Trigger.

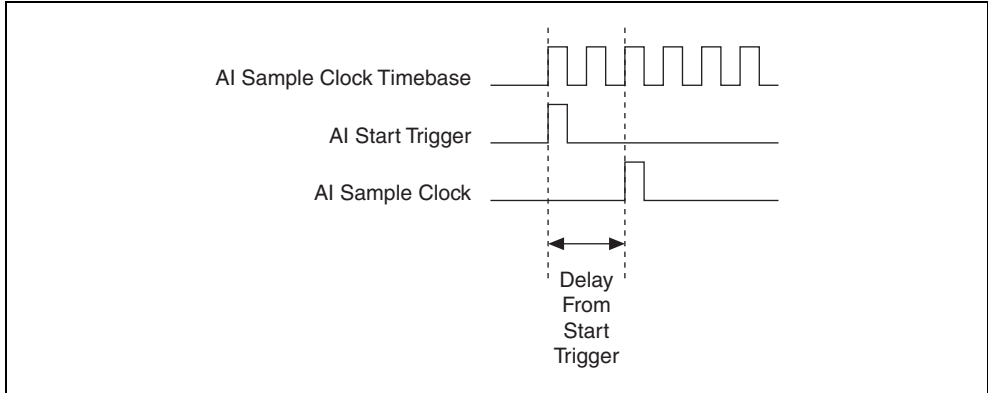

Figure 2-6. AI Sample Clock and AI Start Trigger

AI Sample Clock Timebase Signal

You can route any of the following signals to be the AI Sample Clock Timebase (ai/SampleClockTimebase) signal:

- 100 MHz Timebase (default)
- 20 MHz Timebase
- 100 kHz Timebase
- PXI_CLK10
- PXI_Trig <0..7>
- PFI <0,1>
- PXI_STAR
- PXIe_DSTAR <A, B>

AI Sample Clock Timebase is not available as an output on the I/O connector. AI Sample Clock Timebase is divided down to provide one of the possible sources for AI Sample Clock. You can configure the polarity selection for AI Sample Clock Timebase as either rising or falling edge, except on 100 MHz Timebase or 20 MHz Timebase.

AI Start Trigger Signal

Use the AI Start Trigger (ai/StartTrigger) signal to begin a measurement acquisition. A measurement acquisition consists of one or more samples. If you do not use triggers, begin a measurement with a software command by starting a task, which sends the software command that begins the measurement. Once the acquisition begins, configure the acquisition to stop:

- When a certain number of points are sampled (in finite mode)
- After a hardware reference trigger (in finite mode)
- With a software command (in continuous mode)

An acquisition that uses a start trigger (but not a reference trigger) is sometimes referred to as a posttriggered acquisition.

Retriggerable Analog Input

The AI Start Trigger can also be configured to be retriggerable. The timing engine will generate the sample and convert clocks for the configured acquisition in response to each pulse on an AI Start Trigger signal.

The timing engine ignores the AI Start Trigger signal while the clock generation is in progress. After the clock generation is finished, the counter waits for another Start Trigger to begin another clock generation. Figure 2-7 shows a retriggerable analog input with three AI channels and four samples per trigger.

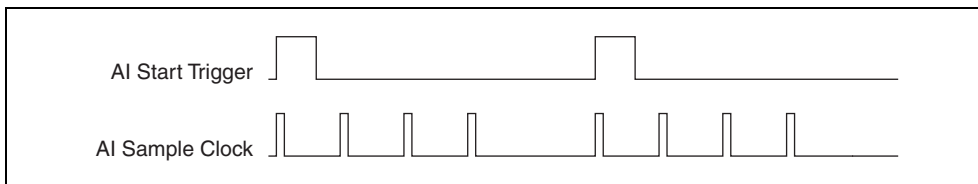

Figure 2-7. Retriggerable Analog Input



Note Waveform information from LabVIEW will not reflect the delay between triggers. They will be treated as a continuous acquisition with constant t_0 and dt information.

Reference triggers are not retriggerable.

Using a Digital Source

To use AI Start Trigger with a digital source, specify a source and an edge. The source can be any of the following signals:

- PFI <0, 1>
- PXI_Trig <0..7>
- PXI_STAR
- PXIe_DSTAR <A, B>

The source also can be one of several other internal signals on your DAQ device. Refer to *Device Routing in MAX* in the *NI-DAQmx Help* or the *LabVIEW Help* for more information.

You also can specify whether the measurement acquisition begins on the rising edge or falling edge of AI Start Trigger.

Routing AI Start Trigger to an Output Terminal

You can route AI Start Trigger out to any PXI_Trig <0..7> or PXIe_DSTARC terminal. The output is an active high pulse. All PFI terminals are configured as inputs by default.

The device also uses AI Start Trigger to initiate pretriggered DAQ operations. In most pretriggered applications, a software trigger generates AI Start Trigger. Refer to the *AI Reference Trigger Signal* section for a complete description of the use of AI Start Trigger and AI Reference Trigger in a pretriggered DAQ operation.

AI Reference Trigger Signal

Use AI Reference Trigger (ai/ReferenceTrigger) signal to stop a measurement acquisition. To use a reference trigger, specify a buffer of finite size and a number of pretrigger samples (samples that occur before the reference trigger). The number of posttrigger samples (samples that occur after the reference trigger) desired is the buffer size minus the number of pretrigger samples.

Once the acquisition begins, the DAQ device writes samples to the buffer. After the DAQ device captures the specified number of pretrigger samples, the DAQ device begins to look for the reference trigger condition. If the reference trigger condition occurs before the DAQ device captures the specified number of pretrigger samples, the DAQ device ignores the condition.

If the buffer becomes full, the DAQ device continuously discards the oldest samples in the buffer to make space for the next sample. This data can be accessed (with some limitations) before the DAQ device discards it. Refer to the KnowledgeBase document, *Can a Pretriggered Acquisition be Continuous?*, for more information. To access this KnowledgeBase, go to ni.com/info and enter the Info Code `rdcanq`.

When the reference trigger occurs, the DAQ device continues to write samples to the buffer until the buffer contains the number of posttrigger samples desired. Figure 2-8 shows the final buffer.

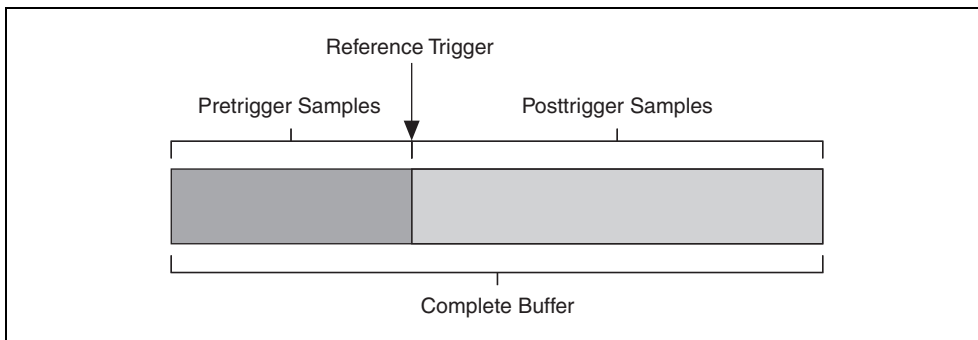

Figure 2-8. Reference Trigger Final Buffer

Using a Digital Source

To use AI Reference Trigger with a digital source, specify a source and an edge. The source can be any of the following signals:

- PFI <0, 1>
- PXI_Trig <0..7>
- PXI_STAR
- PXIe_DSTAR <A, B>

The source also can be one of several internal signals on your DAQ device. Refer to *Device Routing in MAX* in the *NI-DAQmx Help* or the *LabVIEW Help* for more information.

You also can specify whether the measurement acquisition stops on the rising edge or falling edge of AI Reference Trigger.

Using an Analog Source

When you use an analog trigger source, the acquisition stops on the first rising edge of the Analog Comparison Event signal.

Routing AI Reference Trigger Signal to an Output Terminal

You can route AI Reference Trigger out to any PXI_Trig <0..7>, or PXIe_DSTARC terminal.

All PFI terminals are configured as inputs by default.

AI Pause Trigger Signal

Use the AI Pause Trigger (ai/PauseTrigger) signal to pause and resume a measurement acquisition. The internal sample clock pauses while the external trigger signal is active and resumes when the signal is inactive. You can program the active level of the pause trigger to be high or low, as shown in Figure 2-9. In the figure, T represents the period, and A represents the unknown time between the clock pulse and the posttrigger.

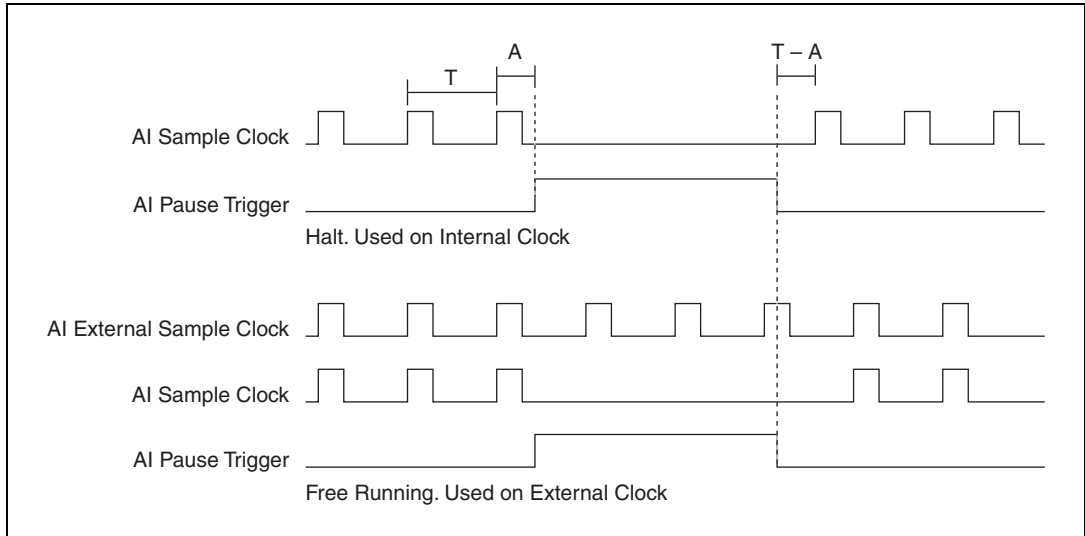

Figure 2-9. Halt (Internal Clock) and Free Running (External Clock)

Using a Digital Source

To use AI Pause Trigger, specify a source and a polarity. The source can be any of the following signals:

- PFI <0, 1>
- PXI_Trig <0..7>
- PXI_STAR
- PXIe_DSTAR <A, B>

The source also can be one of several other internal signals on your DAQ device. Refer to *Device Routing in MAX* in the *NI-DAQmx Help* or the *LabVIEW Help* for more information.

Routing AI Pause Trigger Signal to an Output Terminal

You can route AI Pause Trigger out to any PXI_Trig <0..7>, PXI_STAR, or PXIe_DSTARC terminal.



Note Pause triggers are only sensitive to the level of the source, not the edge.

Getting Started with AI Applications in Software

You can use the NI PXIe-4300 modules in the following analog input applications:

- Simultaneous sampling
- Single-point analog input
- Finite analog input
- Continuous analog input

You can perform these applications through DMA or programmed I/O data transfer mechanisms. Some of the applications also use start and reference pause triggers.



Note For more information about programming analog input applications and triggers in software, refer to the *NI-DAQmx Help* or the *LabVIEW Help* in version 8.0 or later.

NI PXIe-4300 modules use the NI-DAQmx driver. NI-DAQmx includes a collection of programming examples to help you get started developing an application. You can modify example code and save it in an application. You can use examples to develop a new application or add example code to an existing application.

To locate LabVIEW, LabWindows™/CVI™, Measurement Studio, Visual Basic, and ANSI C examples, refer to the KnowledgeBase document, *Where Can I Find NI-DAQmx Examples?*, by going to ni.com/info and entering the Info Code `daqmxexp`.

For additional examples, refer to zone.ni.com.

External Reference Clock

An external reference clock can be used as a source for the internal timebase on the NI PXIe-4300. This clock can be sourced using the signals shown in Table 2-5. Since the clock is the input of a PLL, it must be 5 MHz, 10 MHz, 20 MHz, or 100 MHz. A PLL locks to the signal and produces a 100 MHz output, which is then divided down to produce the three timebases of 100 MHz, 20 MHz and 100 kHz. These timebases can then be used to generate sample clocks on the device. This circuit also enables the output of a 10 MHz RefClk that can be routed to PXI_Trig<0..7> and used by another device as its own External Reference Clock as shown in Figure 2-10.

Table 2-5. Clock Signal Sourcing

Signal	Description
PXI_Trig<0..7>	Bi-Directional bus connecting each board in the chassis.
PFI<0..1>	External User Input
PXIe_Clk100	100 MHz clock routed to all slots in the chassis.
PXI_STAR	Point to point route from the System Timing Slot to all other slots.
PXIe_DSTAR <A, B>	Point to point differential routes from the System Timing Slot to all other slots.

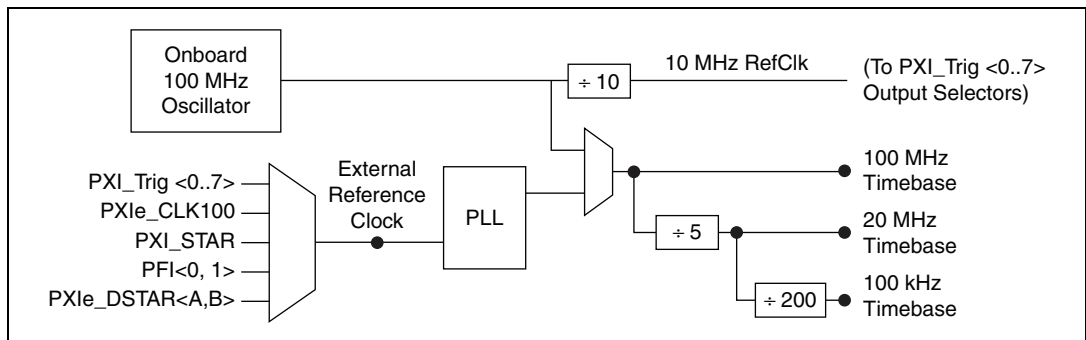

Figure 2-10. External Clock Reference



Caution Do not disconnect an external reference clock once the modules have been synchronized or are used by a task. Doing so may cause NI-DAQmx to return an error. Make sure that all tasks using a reference clock are stopped before disconnecting it.

10 MHz Reference Clock

The 10 MHz reference clock can be used to synchronize other devices to the NI PXIe-4300 module. The 10 MHz reference clock can be routed to the PXI_Trig <0..7> terminals. Other devices connected to the PXI_Trig bus can use this signal as a clock input.

The 10 MHz reference clock is generated by dividing down the onboard oscillator.

Synchronizing Multiple Devices

On PXI Express systems, you can synchronize devices to PXIe_CLK100. In this application the PXI Express chassis acts as the initiator. Each PXI Express module uses PXIe_CLK100 as its reference clock. Adding channels from multiple modules to the same NI-DAQmx task will perform synchronization automatically.

Another option in PXI Express systems is to use PXI_STAR. The Star Trigger controller device acts as the initiator and drives PXI_STAR with a clock signal. Each target module uses PXI_STAR as its external reference clock.

With the PXI_Trig bus and the routing capabilities of the NI PXIe-4300 module, there are several ways to synchronize multiple modules depending on your application.

To synchronize multiple modules to a common timebase, choose one module—the master—to generate the timebase. The master module routes its 10 MHz reference clock to one of the PXI_Trig <0..7> signals.

All modules (including the master module) receive the 10 MHz reference clock from PXI_Trig. This signal becomes the external reference clock. A PLL on each module generates the internal timebases synchronous to the external reference clock.

Sharing a trigger between multiple devices using PXI trigger lines introduces skew in the trigger signal, due to the propagation delay of the signal. The NI PXIe-4300 can compensate for that skew by locking the trigger to a clock (PXIe_SYNC100) that is derived from the reference clock (PXIe_CLK100). When you lock triggers to a clock, the device responds to those triggers on a subsequent edge of that clock, rather than immediately. Therefore, skew correction results in increased latency.

When you add multiple NI PXIe-4300 modules to the same NI-DAQmx task, NI-DAQmx automatically enables trigger skew correction. To enable trigger skew correction for applications that use multiple NI-DAQmx tasks, specify which device is the master and which devices are the slaves using the **SyncType** DAQmx Trigger property.

Once all of the devices are using or referencing a common timebase, you can synchronize operations across them by sending a common start trigger out across the PXI_Trig bus and setting their sample clock rates to the same value as shown in Figure 2-11.

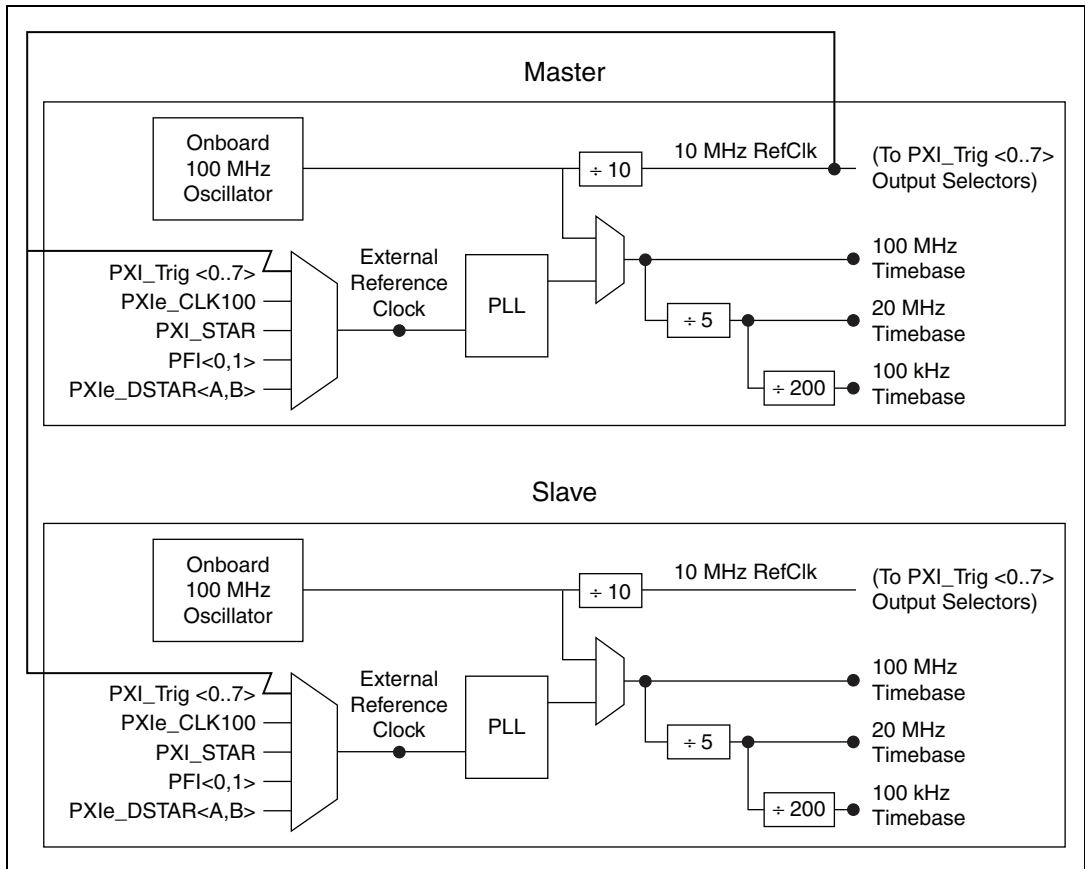

Figure 2-11. Synchronization Operation

Triggering

The following sections provide details about analog and digital triggering of the NI PXIe-4300 module.

Analog Triggering

You can configure the NI PXIe-4300 analog trigger circuitry to monitor any input channel from which you acquire data. Choosing an input channel as the trigger channel does not influence the input channel acquisition capabilities.

The analog trigger signal can be used as a reference trigger only. This restriction is due to the fact that the analog trigger circuit operates on digitized ADC data, requiring the acquisition to be running in order for the analog trigger circuit to operate. In a reference triggered

acquisition, you configure the device to acquire a certain number of pre-trigger samples and a certain number of post-trigger samples.

The trigger circuit generates an internal digital trigger based on the input signal and the user-defined trigger levels.

For example, you can configure the device to generate an analog comparison event after the input signal crosses a specific threshold. You also can route the resulting reference trigger event to the NI PXIe trigger bus to synchronize the triggering of other devices in the system.

During repetitive triggering on a waveform, you might observe jitter because of the uncertainty of where a trigger level falls compared to the actual digitized data. Although this trigger jitter is never greater than one sample period, it might be significant when the sample rate is only twice the bandwidth of interest. This jitter usually has no effect on data processing, and you can decrease this jitter by sampling at a higher rate. Sampling at a rate less than twice the bandwidth of interest may cause the trigger signal to not reliably be detected.

You can use the following analog triggering modes with the NI PXIe-4300 modules: rising-edge, rising-edge with hysteresis, falling-edge, falling-edge with hysteresis, entering window, and leaving window.

Analog Edge Triggering

For analog edge triggering, configure the device to detect a certain signal level and slope, either rising or falling. Figure 2-12 shows an example of rising edge analog triggering. The trigger asserts when the signal starts below level and then crosses above level.

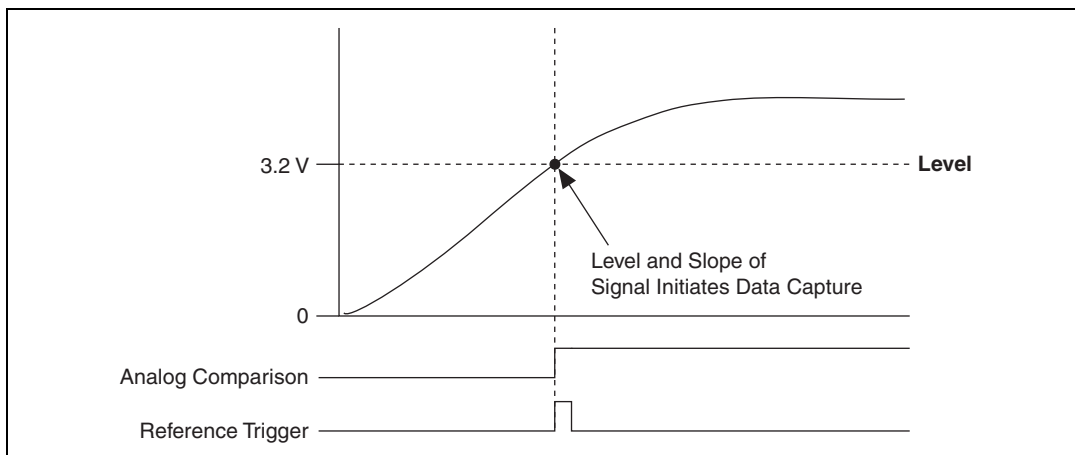

Figure 2-12. Analog Trigger Level

Analog Edge Triggering With Hysteresis

When you add hysteresis to analog edge triggering, you add a window above or below the trigger level. This trigger often is used to reduce false triggering due to noise or jitter in the signal. For example, if you add a hysteresis of 1 V to the example in Figure 2-12, which uses a level of 3.2 V, the signal must start at or drop below 2.2 V to arm the trigger. The trigger asserts when the signal rises above 3.2 V and deasserts when it falls below 2.2 V, as shown in Figure 2-13.

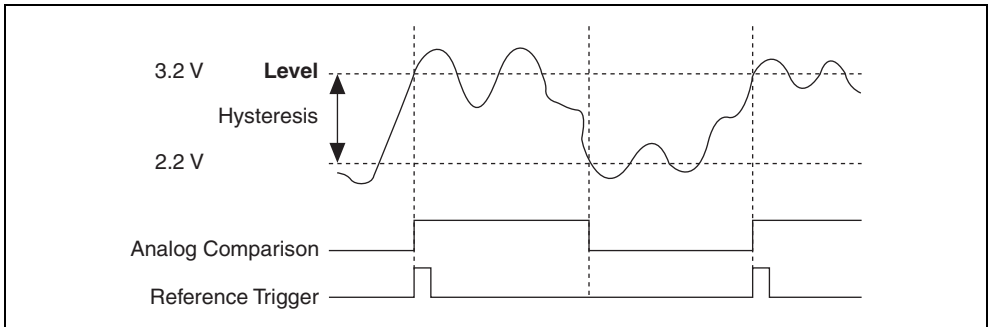

Figure 2-13. Analog Edge Triggering with Hysteresis on Rising Slope

When using hysteresis with a falling slope, the trigger is armed when the signal starts above Level, plus the hysteresis value, and asserts when the signal crosses below Level. For example, if you add a hysteresis of 1 V to a level of 3.2 V, the signal must start at or rise above 4.2 V to arm the trigger. The trigger asserts as the signal falls below 3.2 V and deasserts when it rises above 4.2 V, as shown in Figure 2-14.

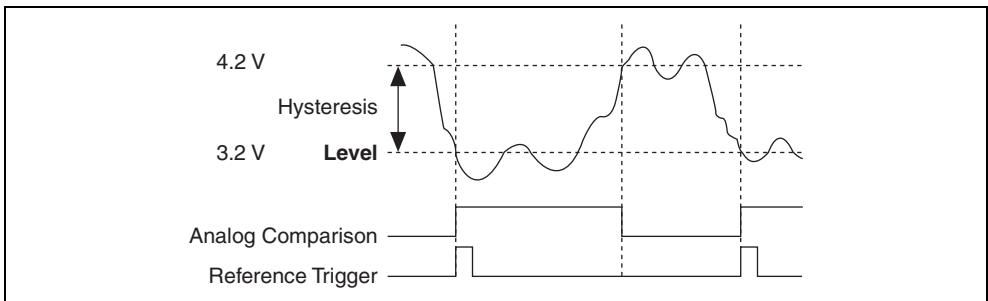

Figure 2-14. Analog Edge Triggering with Hysteresis on Falling Slope

Window Triggering

A window trigger occurs when an analog signal either passes into (enters) or passes out of (leaves) a window defined by two levels. Specify the levels by setting a value for the top and bottom window boundaries. Figure 2-15 demonstrates a trigger that acquires data when the signal enters the window. You can also program the trigger circuit to acquire data when the signal leaves the window.

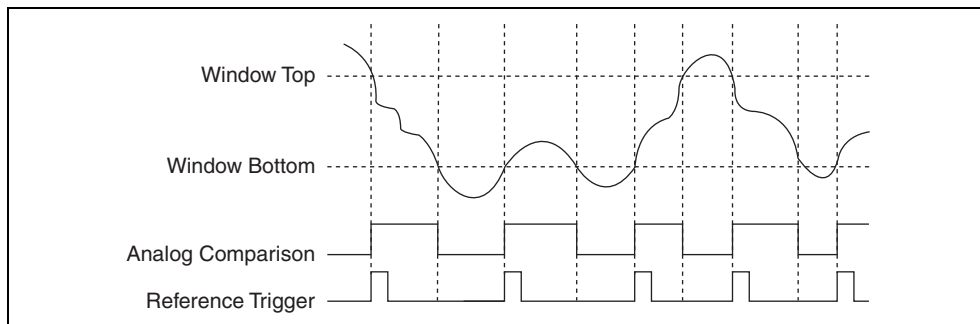

Figure 2-15. Window Triggering

Digital Input Triggering

You can configure the NI PXIe-4300 device to start or pause an acquisition in response to a digital trigger signal from either PFI<0..1>, PXIe_DSTAR <A, B>, PXI_Trig<0..7>, or PXI_STAR. The trigger circuit can respond to a rising, falling, or level sensitive signal, in one of the following three modes:

- **Start**—Begins an acquisition when trigger is met.
- **Reference**—A certain number of pre-trigger and post-trigger samples are specified around the trigger.
- **Pause**—Acquisition is put on hold when trigger is met (level sensitive only).

In addition, the trigger circuit provides a programmable filter to help with noisy trigger signals. The filter checks that the trigger condition is met for different time intervals before triggering. The filter can select from 90 ns, 5.12 μ s, 2.56 ms, or a custom defined time interval. For information about configuring digital filters, refer to the *NI-DAQmx Help*.

TB-4300/4300B Accessory

The TB-4300 and TB-4300B terminal blocks provide screw terminals for access to the module. The TB-4300 is strictly a feedthrough terminal block. The TB-4300B provides 30x attenuation to the input signal with additional high-voltage protection circuitry and expands the range of the NI PXIe-4300 to 300 V. Scaling constants are stored in the EEPROM and used by software to automatically apply scaling to the signal for the selected range.

Accessory Auto-Detection

NI SC Express modules automatically detect compatible accessories or terminal blocks. The RSVD pins on the I/O connector provide power to the accessories as well as digital communication lines. This allows software to detect when accessories are inserted or removed. In addition, software can automatically identify the specific terminal block as well as access any scaling information associated with the terminal block.

MAX allows you to see what accessories are currently connected to your module. In MAX, expand **Devices and Interfaces** and locate your module. If a terminal block is connected to your module, it will be displayed beneath the module. Unsupported terminal blocks appear in MAX with an X next to them.

NI-DAQmx property nodes can be used to programmatically access information about connected accessories in your application. Refer to the *NI-DAQmx Help* for documentation about programmatically accessing accessory status. Select **Start»All Programs»National Instruments»NI-DAQ»NI-DAQmx Help**.

Accessory Power

The NI PXIe-4300 provides auxiliary power for accessories connected to the module and has protection in the event of a fault condition. If a fault occurs in the form of an over-power condition, the power supply latches off until it is reset. To reset after a fault condition perform a Device Reset in MAX or programmatically in your ADE.

Isolation



Caution Refer to the *Read Me First: Safety and Electromagnetic Compatibility*, included with your module, for more safety information.

The NI PXIe-4300 provides 300 V channel-to-channel basic isolation as well as 300 V channel-to-earth reinforced isolation. This rating is intended for measurements within Measurement Category II. These isolation levels are verified with a 5second dielectric withstand test. Refer to the *NI PXIe-4300 Specifications* for details.

Measurement Category II is for measurements performed on circuits directly connected to the electrical distribution system. This category refers to local-level electrical distribution, such as that provided by a standard wall outlet, for example, 115 V for U.S. or 230 V for Europe.

Do not connect the NI PXIe-4300 module to signals or use for measurements within Measurement Categories III or IV.

NI SC Express Considerations

PXI clock and trigger signals are only available on PXI Express devices.

PXI and NI SC Express Clock and Trigger Signals

PXIe_CLK100

PXIe_CLK100 is a common low-skew 100 MHz reference clock for synchronization of multiple modules in a PXI Express measurement or control system. The PXIe backplane is responsible for generating PXIe_CLK100 independently to each peripheral slot in a PXI Express chassis. For more information, refer to the *PXI Express Specification* at www.pxisa.org.

PXIe_SYNC100

PXIe_SYNC100 is a common, low-skew 10 MHz reference clock with a 10% duty cycle for synchronization of multiple modules in a PXI Express measurement or control system. The PXI Express backplane is responsible for generating PXIe_SYNC100 independently to each peripheral slot in a PXI Express chassis. For more information, refer to the *PXI Express Specification* at www.pxisa.org.

PXI_CLK10

PXI_CLK10 is a common low-skew 10 MHz reference clock for synchronization of multiple modules in a PXI measurement or control system. The PXI backplane is responsible for generating PXI_CLK10 independently to each peripheral slot in a PXI chassis.



Note PXI_CLK10 cannot be used as a reference clock for SC Express modules.

PXI Triggers

A PXI chassis provides eight bused trigger lines to each module in a system. Triggers may be passed from one module to another, allowing precisely timed responses to asynchronous external events that are being monitored or controlled. Triggers can be used to synchronize the operation of several different PXI peripheral modules.

On SC Express modules, the eight PXI trigger signals are synonymous with PXI_Trig <0..7>.

Note that in a PXI chassis with more than eight slots, the PXI trigger lines may be divided into multiple independent buses. Refer to the documentation for your chassis for details.

PXI_STAR Trigger

In a PXI Express system, the Star Trigger bus implements a dedicated trigger line between the system timing slot and the other peripheral slots. The Star Trigger can be used to synchronize multiple devices or to share a common trigger signal among devices.

A Star Trigger controller can be installed in this system timing slot to provide trigger signals to other peripheral modules. Systems that do not require this functionality can install any standard peripheral module in this system timing slot.

An SC Express module receives the Star Trigger signal (PXI_STAR) from a Star Trigger controller. PXI_STAR can be used as an external source for many AI, AO, and counter signals.

An SC Express module is not a Star Trigger controller. An SC Express module can be used in the system timing slot of a PXI system, but the system will not be able to use the Star Trigger feature.

PXI_STAR Filters

You can enable a programmable debouncing filter on each PFI, PXI_Trig, PXIe_DSTAR, or PXI_STAR signal.

PXIe_DSTAR <A..C>

PXI Express devices can provide high-quality and high-frequency point-to-point connections between each slot and a system timing slot. These connections come in the form of three low-voltage differential star triggers that create point-to-point, high-frequency connections between a PXI Express system timing module and a peripheral device. Using multiple connections enable you to create more applications because of the increased routing capabilities.

Table 3-1 describes the three differential star (DSTAR) lines and how they are used.

Table 3-1. PXIe_DSTAR Line Descriptions

Trigger Line	Purpose
PXIe_DSTARA	Distributes high-speed, high-quality clock signals from the system timing slot to the peripherals (input).
PXIe_DSTARB	Distributes high-speed, high-quality trigger signals from the system timing slot to the peripherals (input).
PXIe_DSTARC	Sends high-speed, high-quality trigger or clock signals from the peripherals to the system timing slot (output).

The DSTAR lines are only available for PXI Express devices when used with a PXI Express system timing module. For more information, refer to the *PXI Express Specification* at www.pxisa.org.

Data Transfer Methods

The primary ways to transfer data across the PCI Express bus are as follows:

- **Direct Memory Access (DMA)**—DMA is a method to transfer data between the device and computer memory without the involvement of the CPU. This method makes DMA the fastest available data transfer method. NI uses DMA hardware and software technology to achieve high throughput rates and increase system utilization. DMA is the default method of data transfer for PCI Express and PXI Express devices.
- **Programmed I/O**—Programmed I/O is a data transfer mechanism where the user's program is responsible for transferring data. Each read or write call in the program initiates the transfer of data. Programmed I/O is typically used in software-timed (on-demand) operations.



Technical Support and Professional Services

Visit the following sections of the award-winning National Instruments Web site at ni.com for technical support and professional services:

- **Support**—Technical support at ni.com/support includes the following resources:
 - **Self-Help Technical Resources**—For answers and solutions, visit ni.com/support for software drivers and updates, a searchable KnowledgeBase, product manuals, step-by-step troubleshooting wizards, thousands of example programs, tutorials, application notes, instrument drivers, and so on. Registered users also receive access to the NI Discussion Forums at ni.com/forums. NI Applications Engineers make sure every question submitted online receives an answer.
 - **Standard Service Program Membership**—This program entitles members to direct access to NI Applications Engineers via phone and email for one-to-one technical support as well as exclusive access to on demand training modules via the Services Resource Center. NI offers complementary membership for a full year after purchase, after which you may renew to continue your benefits.
 - For information about other technical support options in your area, visit ni.com/services, or contact your local office at ni.com/contact.
- **Training and Certification**—Visit ni.com/training for self-paced training, eLearning virtual classrooms, interactive CDs, and Certification program information. You also can register for instructor-led, hands-on courses at locations around the world.
- **System Integration**—If you have time constraints, limited in-house technical resources, or other project challenges, National Instruments Alliance Partner members can help. To learn more, call your local NI office or visit ni.com/alliance.
- **Declaration of Conformity (DoC)**—A DoC is our claim of compliance with the Council of the European Communities using the manufacturer’s declaration of conformity. This system affords the user protection for electromagnetic compatibility (EMC) and product safety. You can obtain the DoC for your product by visiting ni.com/certification.
- **Calibration Certificate**—If your product supports calibration, you can obtain the calibration certificate for your product at ni.com/calibration.

If you searched ni.com and could not find the answers you need, contact your local office or NI corporate headquarters. Phone numbers for our worldwide offices are listed at the front of this manual. You also can visit the Worldwide Offices section of ni.com/niglobal to access the branch office Web sites, which provide up-to-date contact information, support phone numbers, email addresses, and current events.