

ENG460: Engineering Thesis

Measurement of Induction Motor Parameters
Using the Voltech PM6000 Power Analyser



Murdoch
UNIVERSITY

Ashley Van Niekerk

Supervisor: Dr Sujeewa Hettiwatte
Co-supervisor: Assoc. Prof. Graeme Cole

22/12/2014

Acknowledgements

I'd like to thank Dr Sujeewa Hettiwatte, Mr Lafeta Laava and Mr John Boulton for their ongoing support throughout this project.

Table of Contents

Tables	4
Figures.....	4
1 Introduction	5
1.1 Overview	5
1.2 Approach.....	6
2 Induction Motors	7
2.1 Operation	7
2.2 Squirrel Cage vs. Wound Rotor Design	8
2.3 Equivalent Circuit	8
3 Test Procedure	10
3.1 DC test.....	10
3.2 No Load Test	10
3.3 Locked Rotor test	12
4 System Components	15
4.1 PM6000 Power Analyser.....	15
4.1.1 Operation	15
4.1.2 Menu Items	15
4.1.3 Input	16
4.1.4 Setup	17
4.1.5 Display.....	18
4.1.6 Establishing a connection to a Computer	18
4.1.7 Specifications	19
4.2 Variable Frequency Drive.....	20
4.2.1 Operation	20
4.2.2 Specifications	23
4.3 Toshiba Motor.....	24
4.3.1 Specifications	24
4.4 Leroy Somer Motor	25
4.4.1 Specifications	25
5 System Design	27
5.1 System Schematics.....	27
5.2 Australian Wiring Standards	30
6 Results	33

6.1	Toshiba Motor.....	33
6.1.1	Calculations	35
6.1.2	Torque speed characteristics	38
6.2	Leroy Somer Motor	38
6.2.1	Calculations	40
6.2.2	Torque speed characteristics	42
7	Conclusion.....	43
8	Future Work	44
8.1	Low Pass Filter.....	44
8.2	Calibration of the Power Analyser	46
8.3	Dynamometer	46
9	Appendices.....	47
9.1	Appendix 1 - Matlab Program for Torque Speed Characteristic Curve	47
9.2	Appendix 2 - Matlab Program for Frequency Response of Proposed RC Filter	48
9.3	Appendix 3 - Matlab Program for PWM Output of the Variable Frequency Drive.....	49
9.4	Appendix 4 - Test Methods Recommended by IEEE	50
9.4.1	The No Load test	50
9.4.2	Method 1.....	50
9.4.3	Method 2.....	52
9.4.4	Method 3.....	52
9.4.5	Method 4.....	54
10	Bibliography	55

Tables

Table 1 - Rules of thumb for separating the stator and rotor circuit reactances	14
Table 2 - Menu and submenu items which can be accessed via the keypad	16
Table 3 - Maximum voltage and current that can be measured continuously and over one second ..	19
Table 4 - Maximum and minimum ratings for power that can be supplied to PM6000	19
Table 5 - Dielectric strength of inputs and outputs	19
Table 6 - Electrical and temperature specifications for the Movitrac 07 unit.....	24
Table 7 - Nameplate information for the Toshiba motor	24
Table 8 - Nameplate information for the Leroy Somer motor	25
Table 9 - Data from the locked rotor test performed using the 50Hz Lab-Volt power supply.....	33
Table 10 - Data from the locked rotor test performed at reduced frequency using the VFD	33
Table 11 - No load test data	34
Table 12 - DC test data.....	35
Table 13 - Data from the locked rotor test performed using the 50Hz Lab-Volt power supply.....	39
Table 14 - Data from the locked rotor test performed at reduced frequency using the VFD	39
Table 15 - No load test data	39
Table 16 - DC test data.....	39

Figures

Figure 1 - Per-phase equivalent circuit	9
Figure 2 - Approximation of the equivalent circuit under no load conditions	11
Figure 3 - Approximation of the equivalent circuit for the locked rotor test	12
Figure 4 - Rear view showing connections to Lab-Volt equipment	15
Figure 5 - Front view showing digital display.....	16
Figure 6 - Diagram showing triangle and sine waves placed through a comparator	21
Figure 7 - Circuit diagram for a PWM VFD	22
Figure 8 - Block diagram for a typical Variable Frequency Drive	23
Figure 9 - Isometric view of the unit which is rated for 0.37kW AC machines.....	23
Figure 10 - Wiring Configuration for DC test	28
Figure 11 - Wiring Configuration for no load test.....	28
Figure 12 - Wiring Configuration for the locked rotor test.....	29
Figure 13 - Connections to Power Analyser.....	29
Figure 14 - Circuit diagram showing parallel branches combined.....	36
Figure 15 - Simulated torque-speed curve for the Toshiba induction motor.....	38
Figure 16 - Simulated torque-speed curve for the Leroy Somer induction motor	42
Figure 17 - Circuit diagram for a first order low pass RC filter	44
Figure 18 - Schematic for the proposed three phase RC filter	45
Figure 19 - Frequency response of the proposed first-order low pass filter	46
Figure 20 - The total reactance from the no load test.....	53

1 Introduction

1.1 Overview

The aim of this project was to configure the Voltech PM6000 Power Analyser to measure the voltages, currents and power in two different induction motors under various test conditions. These measurements were then used to determine the parameters of each motor's equivalent circuit. The equivalent circuit is a per-phase representation of a three phase induction motor that can be used to model a real-world machine.

Parameters that were determined include the stator and rotor impedances and the magnetising reactance of the motors. Also, the stator copper losses and rotational losses were found. The resistance R_c corresponding to core loss was not considered in the analysis. Core losses include hysteresis and eddy current losses which, during normal operation, are very small and thus have been ignored.

The calculated parameter values were used to generate torque speed curves in Matlab. By measuring the torque of the motors directly and by comparing various points in the stable region of the motors' actual torque speed curves with the curves that were generated in Matlab, it is possible to verify that the calculated circuit parameters are correct.

The Voltech PM6000 is a versatile measurement tool with six configurable channels for AC and DC analysis. It can be used in a variety of applications ranging from power supplies operating in standby mode to high frequency power converters. Its accuracy and bandwidth allows it to take measurements of all power quantities on any piece of electrical equipment (Voltech Instruments Inc. 2009). Another advantage of using this unit is that it eliminates the problem of needing several multimeters to take readings on multiple phases. This report provides an introduction to the setup and operation of the Power Analyser, specifically for the types of experiments that have been undertaken during this project.

In Section 5 a series of wiring configurations have been proposed that future students could use as a guide for performing each of the three parameter tests, which are discussed in Section 3. In addition, alternative tests methods recommended by the IEEE Power Engineering Society are given in Appendix 4. These are provided for information purposes only and were not directly used at any stage during this project, however they should yield similar results to the methods that have been used.

For the benefit of the reader some background theory has also been given on the design and operation of induction motors as well as the other equipment that has been used throughout this project. Also clauses from the AS/NZ 3000 Wiring Rules have been listed which provide important information about safety, wiring and operation of electrical systems which should be taken into consideration when using the equipment.

An analysis of results has been provided which includes the theoretical calculations that were performed and a discussion of the reliability of the measured data. Some recommendations have been made to further improve the project in Section 8.

1.2 Approach

This project began with preliminary research into the principles of operation of induction motors and the recommended test procedures. After this, a review of the Australian wiring standards was conducted and a series of circuit diagrams were developed for each parameter test. Once these were approved, the relevant equipment was acquired.

Some of the equipment that was used had to be modified. In particular, the motor shafts had to be fitted with detachable plates that were used to lock the rotors in position for one of the tests. Also, some of the leads were not compatible. Terminal boxes were made which replaced the three phase plugs that were fitted to the motors. This allowed connections to be made to the Power Analyser. After the modifications were completed, testing could begin.

2 Induction Motors

Section 2 summarises the design and operation of induction motors. It also highlights the differences between squirrel cage and wound rotor designs and compares each rotor type in terms of their performance characteristics. The final part of this chapter introduces the equivalent circuit which is a single phase representation of a three phase induction motor which can be used to model a real world machine if its parameters are known.

2.1 Operation

Induction motors work by supplying a balanced three phase voltage to the stator windings. The current flowing through the windings produces a magnetic field which rotates at synchronous speed (N_s) (Indian Institute of Technology 2006).

The flux lines of the magnetic field cut through the rotor, which is stationary at start. An electromotive force (EMF) is then induced in the rotor at the supply frequency. This causes current to flow in the rotor creating a magnetic field. The rotor magnetic field interacts with the stator field to produce a turning force. This torque causes the rotor to turn in the same direction as the rotating magnetic field and the relative speed between the two decreases (Indian Institute of Technology 2006).

The rotor speed (N_r) will however never reach the speed of the magnetic field (synchronous speed) because torque which is proportional to $N_s - N_r$ is needed to keep the rotor spinning. At synchronous speed, the induced EMF and the current in the rotor would reduce to zero and there would be no torque produced. For this reason, the rotor speed will always be less than N_s . The rotor speed will vary depending on the size of the mechanical load connected to the shaft and the rotor losses, which comprises mainly of copper losses (Indian Institute of Technology 2006).

The difference between synchronous speed and the rotor speed is termed as the slip of the motor and is usually expressed by the following ratio:

$$s = \frac{N_s - N_r}{N_s} \quad (1)$$

Where N_s and N_r are the synchronous and rotor speeds in rpm

(Indian Institute of Technology 2006)

If the rotor speed is equal to the synchronous speed then the slip is zero. With the rotor at rest the slip is equal to one. With the torque varied from the no load to the full load value, the slip is proportional to the torque. At full load the slip will increase with the size of the motor (usually between 1% and 5%).

As discussed before, the frequency f_r of the EMF and also the current induced in the rotor at start-up are equal to the supply frequency f . The rotor frequency is a function of the slip where:

$$f_r = p \times (N_s - N_r) = s \times f \quad (2)$$

where N_s and N_r are given in rev/s, and p is the number of magnetic poles

As the slip is generally small during normal operation f_r will only be a small fraction of the 50Hz supply frequency. When stationary, the N_r is equal to zero and f_r will be equal to f (Indian Institute of Technology 2006).

2.2 Squirrel Cage vs. Wound Rotor Design

Induction motors with squirrel cage rotors are robust in design and are used more commonly in industry than induction motors with wound rotors. Squirrel cage rotors are made from a laminated core with parallel slits that support conductors. The conductors are riveted to a short-circuiting ring at each end to give the appearance of a cage (The Institution of Electrical Engineers 1997). They are slightly skewed to prevent the rotor from locking and to increase the effective transformation ratio between the rotor and the stator. Also the increased length of the conductors increases the resistance of the rotor which can improve the starting torque and the acceleration time (Daware n.d.).

An advantage of the squirrel cage design is that there are no slip rings so sparking will not occur and the cost of these motors is relatively low since less conductive material is needed. On the downside they have a lower starting torque, a high starting current and are quite sensitive to supply voltage fluctuations (Teja, Squirrel Cage Induction Motors: Advantages, Disadvantages and Applications 2011).

Wound rotor motors have a group of coils forming windings which are carried by the rotor. As a result they are more expensive to build but have the advantage of being able to develop a higher starting torque and lesser starting current as compared to a squirrel cage motor. Also the total resistance of these motors is not constant, but can be varied by adjusting the external resistors connected to the rotor circuit at start-up. A fair amount of the heat generated during start-up is dissipated in the resistors (The Institution of Electrical Engineers 1997).

2.3 Equivalent Circuit

For an induction motor to work it relies upon the induction of voltages and currents in the rotor circuit from the stator circuit. Since the induction of voltages and currents in the rotor circuit is basically a transformer operation, the equivalent circuit of the motor ends up looking like a transformer equivalent circuit (Chapman 2003).

The equivalent circuit is a useful tool for determining the response of an induction motor to changes in load. If the circuit is to be used to model a real machine the parameters of the model need to be determined. These parameters are derived from test data measured during the three tests described in Section 3. The equivalent circuit, as shown in Figure 1, is a single phase representation of a three phase wye connected motor, but can be also be used to represent a delta-connected machine (Chapman 2003). In order to simplify the analysis of the circuit the impedances on the rotor side are all referred to the stator side so that the effective turns ratio between the stator and rotor windings does not need to be taken into consideration. As a result, the calculated impedances are not the true impedance values of the motor, but can be used throughout this report where rotor parameters have been specified. Figure 1 has been adapted from the circuit diagram provided in Section 5.9 of the IEEE Standard 112 (IEEE Power Engineering Society 2004).

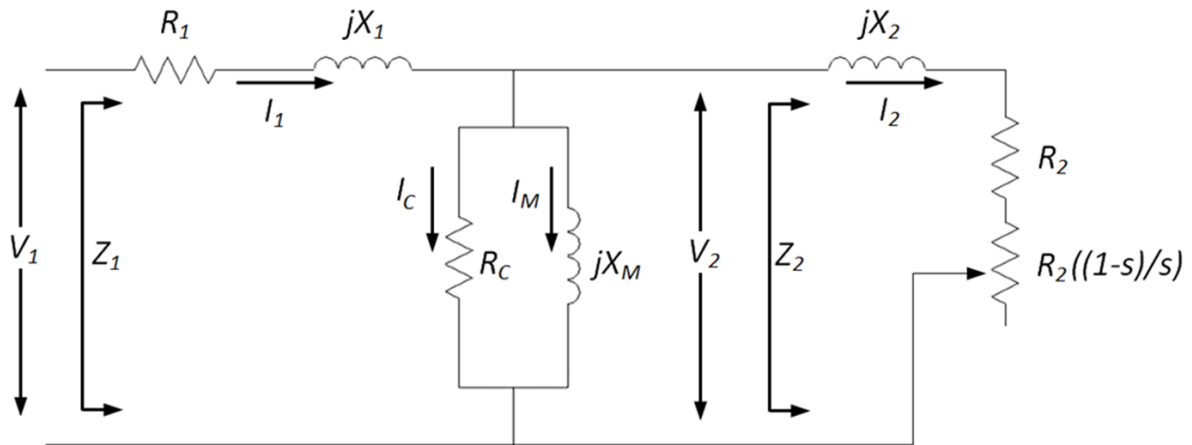

Figure 1 - Per-phase equivalent circuit

With reference to Figure 1, the quantities that are associated with the equivalent circuit and the equations which are used in Section 3 are described below:

V_1 - input phase voltage (V)

V_2 - rotor phase voltage, referred to the stator (V)

I_1 - stator current (A)

I_2 - rotor current, referred to the stator (A)

I_M - magnetizing current (A)

I_C - core loss current, referred to the stator (A)

R_1 - stator resistance (Ω)

R_2 - rotor resistance, referred to the stator (Ω)

R_C - core loss resistance, referred to the stator (Ω)

X_1 - stator leakage reactance (Ω)

X_2 - rotor leakage reactance, referred to the stator (Ω)

X_M - magnetizing reactance (Ω)

Z_1 - the total stator impedance per phase (Ω)

Z_2 - the rotor impedance per phase, referred to the stator (Ω)

s - the slip in p.u.

3 Test Procedure

The circuit parameters of a three phase induction motor, as described in the previous section, can be found by performing a series of tests that are analogous to the short circuit and open circuit tests on a transformer. These tests must be performed under precisely controlled conditions as the operating temperature will affect the internal resistance of the motor and the rotor resistance will also vary with the rotor frequency. If these effects are not taken into account this can lead to misleading results and a set of parameter values that do not accurately represent the motor circuit under normal operating conditions. The precise details of how each induction motor test must be performed to achieve accurate results are described in *IEEE Standard 112: Test Procedure for Polyphase Induction Motors and Generators* (see Appendix 4). Although the details of these tests are quite complex, a simplified approach can be undertaken and is described below.

Note that R_c is not included in these tests. R_c is added to the equivalent circuit model to account for hysteresis and eddy current losses in the motor. However, because these losses are a function of the rotor frequency, the term is only an approximation (Missouri University of Science and Technology n.d.). In addition, if the supply frequency is 50Hz, the slip of the motor will be small, hence the rotor frequency will be quite low and core losses will be negligible.

3.1 DC test

The DC test is performed so that the stator per phase resistance R_1 can be determined (see Figure 1). It can be completed using the system proposed in Section 5 (see Figure 10). With the variable DC source from the Lab-Volt power supply connected to the motor, the supply voltage is gradually increased from zero to the point where the measured stator current is equal to the motor's rated current. The purpose of this test is to heat the windings to the normal operating temperature, since resistance is a function of temperature. Since the current flowing through the stator is DC, no voltage will be induced in the rotor circuit, and so no current will flow in the rotor. As a result, if R_c is ignored, the only parameter limiting current flow is the resistance in the stator windings. Since the DC source is connected to two of the three stator terminals (see Figure 10), the current only flows through two of the windings, so the total resistance path is equal to $2R_1$. Hence, R_1 , the per-phase stator resistance can be found:

$$2R_1 = \frac{V_{DC}}{I_{DC}} \quad (3)$$

$$R_1 = \frac{V_{DC}}{2I_{DC}} \quad (4)$$

The downside with this test is that it does not take into account the skin effect, which is a tendency for AC current to flow mainly around the outer surface of a conductor. This causes the effective stator resistance to be higher when AC power is supplied, particularly at high frequencies (Kothari and Nagrath 2003). Another issue is the effect of temperature. Temperature corrections should be made to correct the calculated resistance value from the test temperature to the temperature the motor would be at during normal operation, and this is not possible unless a thermal sensor can be placed inside the motor.

3.2 No Load Test

The no load test provides information about rotational losses and the magnetisation current of the motor. The motor is connected to a variable AC supply as per Figure 11 (see Section 5) and is allowed

to spin freely. The only loads on the motor are the windage and frictional losses, so all the power consumed by the motor is converted to mechanical losses in the form of heat. The slip of the motor ends up being very small (perhaps less than 0.001). As a result, $R_2(1-s)/s$, the resistance corresponding to the power that is converted is much larger than R_2 , the resistance corresponding to the rotor copper losses, and much larger than the rotor reactance X_2 . Hence, X_2 and R_2 can be ignored, and the equivalent circuit reduces approximately to Figure 2. Under these conditions, the impedance of the motor is essentially a series combination of R_1 , jX_1 and jX_M as shown in Figure 2 (Chapman 2003).

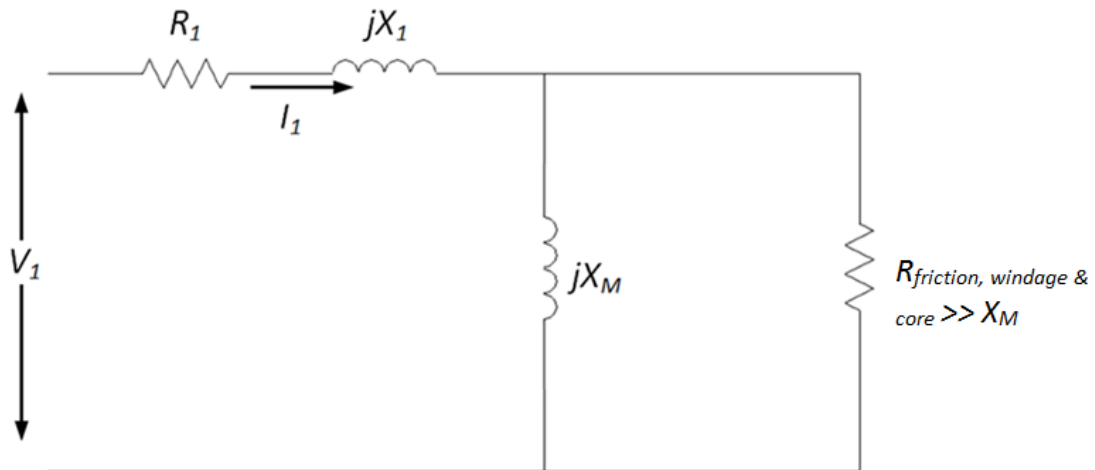

Figure 2 - Approximation of the equivalent circuit under no load conditions

Under no load conditions the power supplied to the motor is equal to the sum of the motor's individual losses. Rotor copper losses are negligible since the rotor current I_2 is extremely small, and can be ignored. Hence, the input power P_{in} is equal to:

$$P_{in} = P_{SCL} + P_{core} + P_{F\&W} + P_{misc} \quad (5)$$

where P_{SCL} is the stator copper losses, P_{core} is the core losses, $P_{F\&W}$ represents the friction and windage losses and P_{misc} is the miscellaneous losses (Chapman 2003). Copper losses occur due to the current flowing through the stator and rotor windings, core losses occur due to hysteresis and eddy currents and frictional losses occur primarily in wound rotor motors when the rotor speed changes. Miscellaneous losses can be caused by a non-uniform current distribution in the motor, and can also include additional core losses developed due to a distortion in the magnetic flux caused by the load current, as well as losses due to harmonic fields (Gonen 2011).

The stator copper losses are given by:

$$P_{SCL} = 3I_1^2 R_1 \quad (6)$$

The rotational losses are given by:

$$P_{rot} = P_{core} + P_{F\&W} + P_{misc} \quad (7)$$

Hence:

$$P_{in} = 3I_1^2 R_1 + P_{rot} \quad (8)$$

(Chapman 2003)

The current needed to establish a magnetic field in an induction motor is large because of the air gap, so the magnetizing reactance X_M will be much smaller than the resistances in parallel and the power factor will also be small. Since the current is lagging, most of the voltage drop will be across the inductive components of the motor and the equivalent impedance will be approximately equal to:

$$|Z_{eq}| = \frac{V_1}{I_{1,nl}} \approx X_1 + X_M \quad (9)$$

(Chapman 2003)

3.3 Locked Rotor test

Combining the results from the previous two tests with the data from a locked rotor test, shortly to be explained, allows X_1 , X_2 , R_2 and X_M to be found. The locked rotor test corresponds to a short-circuit test on a transformer. To perform it the motor is connected as per Figure 12 (see Section 5). Then, the rotor is locked so that rotation is not possible and an AC voltage is supplied to the motor. The voltage is increased until the current reaches the full load value. Then, resulting values for power, phase current and phase voltage are quickly measured using the power analyser, taking care not to overheat the windings. Generally this is not an issue for small motors such as the ones used in this project since the current drawn isn't large enough to cause a significant temperature rise (Chapman 2003).

Since the rotor is stationary, the slip is equal to one, so the resistance in the rotor becomes close to R_2 , which happens to be quite small. Since R_2 and X_2 are small most of the current will flow through them rather than the magnetizing reactance X_M which is much larger in comparison. Under this condition the equivalent circuit can be approximated by a series combination of R_1 , X_1 , R_2 and X_2 as shown in Figure 3 (Chapman 2003).

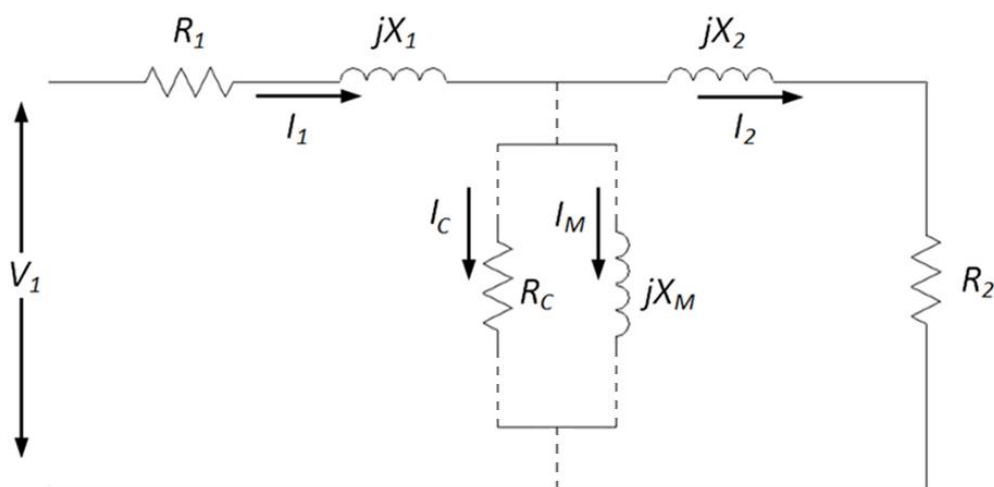

Figure 3 - Approximation of the equivalent circuit for the locked rotor test

When the rotor is stationary the rotor frequency f_r is equal to the supply frequency. However, during normal operation the slip of the motor is quite small. Typically for most motors it is between 2% and 4% (for the Toshiba and Leroy Somer motors their slip at full rated speed is 6% and 8.33% respectively). Therefore, the resulting rotor frequency is much less than the supply frequency (1 to 3Hz). For this reason it is important to conduct the experiment at a reduced frequency (typically 25% or less of the rated value) in order to get accurate results, since the effective rotor resistance is a strong function of f_r . This can be achieved using a variable frequency drive (VFD) (Chapman 2003).

This procedure is generally acceptable for motors with a constant rotor resistance (design Classes A and D), however it could give misleading results when trying to find the resistance of a variable-resistance rotor. As such special care should be taken when obtaining measurements from these tests. After performing the test the machine's impedance values are calculated as follows (Chapman 2003).

The per-phase input power is given by:

$$P_{in} = V_1 \times I_1 \cos(\theta) \quad (10)$$

Where V_1 and I_1 are the average phase voltage and current respectively, and θ is the power (PF) angle.

Rearranging, the locked rotor power factor is equal to:

$$PF = \frac{P_{in}}{V_1 \times I_1} \quad (11)$$

$$\therefore \theta = \cos^{-1}(PF) \quad (12)$$

The magnitude of the per-phase impedance of the motor during this test is given by:

$$|Z_{LR}| = \frac{V_1}{I_1} \quad (13)$$

Z_{LR} consists of both resistive and reactive components which can be found using trigonometry, where:

$$Z_{LR} = R_{LR} + jX'_{LR} \quad (14)$$

$$= |Z_{LR}| \times \cos(\theta) + j|Z_{LR}| \times \sin(\theta) \quad (15)$$

$$\therefore R_{LR} = |Z_{LR}| \times \cos(\theta) \quad (16)$$

$$\therefore X'_{LR} = |Z_{LR}| \times \sin(\theta) \quad (17)$$

The locked rotor resistance R_{LR} is equal to:

$$R_{LR} = R_1 + R_2 \quad (18)$$

Hence, the rotor resistance can be found as:

$$R_2 = R_{LR} - R_1 \quad (19)$$

Where R_1 was determined in the DC test.

The locked rotor reactance X'_{LR} at the test frequency f_{test} is equal to the sum of the rotor and the stator reactances:

$$X'_{LR} = X'_1 + X'_2 \quad (20)$$

Since the reactance and the frequency are proportional to each other, the total equivalent reactance at the normal operating frequency f_{rated} is equal to:

$$X_{LR} = \frac{f_{rated}}{f_{test}} X'_{LR} = X_1 + X_2 \quad (21)$$

In order to separate the contributions of the rotor and stator reactances from each other Table 1 can be used. This table specifies the proportions between X_1 and X_2 for different rotor designs which are defined in NEMA-MG-1, a standard published by the National Electrical Manufacturers Association (NEMA) in the United States (Chapman 2003).

Table 1 - Rules of thumb for separating the stator and rotor circuit reactances

Rotor Design	X_1 and X_2 as functions of X_{LR}	
	X_1	X_2
Wound Rotor	$0.5 X_{LR}$	$0.5 X_{LR}$
Design A	$0.5 X_{LR}$	$0.5 X_{LR}$
Design B	$0.4 X_{LR}$	$0.6 X_{LR}$
Design C	$0.3 X_{LR}$	$0.7 X_{LR}$
Design D	$0.5 X_{LR}$	$0.5 X_{LR}$

Note: In clause 5.5.1 of *IEEE Standard 112* it is recommended that the machine is run for some time before taking measurements to ensure the input power to the motor is stable, especially if the motor has grease lubricated bearings. The reason for this is that the friction losses in the motor will change and will not stabilise until there is no excess grease on the moving parts. Stability is considered to have been reached when the input power under no load conditions does not change by more than 3% between two consecutive readings taken half an hour apart at the same voltage level (IEEE Power Engineering Society 2004).

4 System Components

4.1 PM6000 Power Analyser

The Voltech PM6000 is a versatile measurement tool with six configurable channels for AC and DC analysis. It can be used in a variety of applications ranging from power supplies operating in standby mode to high frequency power converters. Its accuracy and bandwidth allows it to take measurements of all power quantities on any piece of electrical equipment (Voltech Instruments Inc. 2009).

4.1.1 Operation

As specified in Table 3, a maximum voltage of 2000 V peak can be measured, that can be connected directly into the yellow and black safety sockets at each channel (refer to Figure 4).

With the Voltech shunts fitted currents of up to 30A can be measured. These shunts can be mounted directly onto the measurement channels without the need for additional wiring as shown in Figure 4.

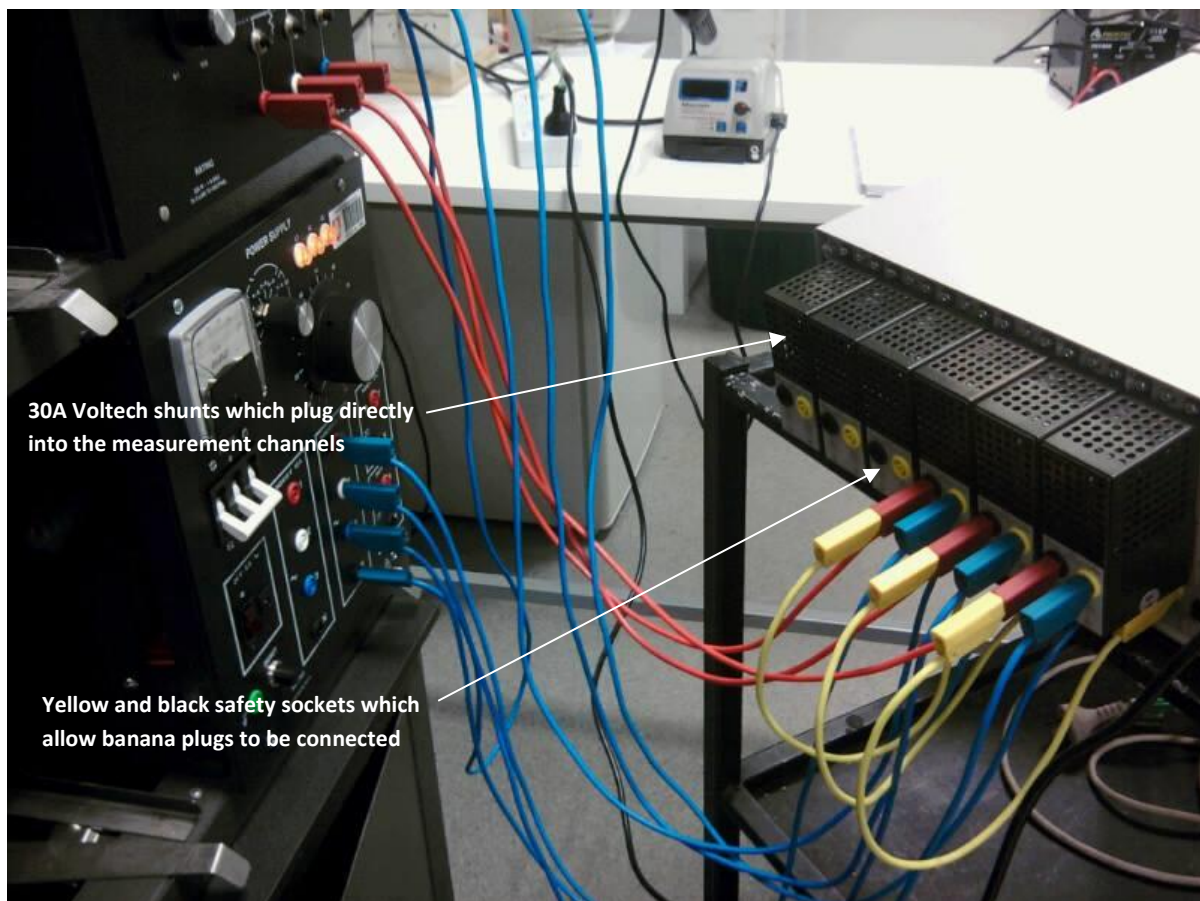

Figure 4 - Rear view showing connections to Lab-Volt equipment. 30A current shunts are fitted to each channel.

4.1.2 Menu Items

In order to configure the Power Analyser for AC and DC measurements the appropriate settings must be selected via the menu using the front panel display of the unit (see Figure 5). Menu items are organised as per Table 2 (Voltech Instruments Inc. 2009).

Table 2 - Menu and submenu items which can be accessed via the keypad

Input	Setup	Display	System	Menus	Other Functions
Wiring Range Coupling Scaling Filter Frequency Curve	Mode Integrator Datalog	Measurement Format Graph	Config Interface Printing Data Trigger Self Test	Menu Help User Menu 1 Menu 2 Menu 3	Hold Reset/Clear Integ Run Data Pump Print

4.1.3 Input

Wiring

The Power Analyser works by assigning channels to groups. For three phase measurements Channel 1, Channel 2 and Channel 3 can be assigned to a single group for precise measurement of each phase. Using this setting Channel 1 becomes the reference phase for the other two phases. A wiring configuration is also selected for the system being analysed. Since there is a neutral wire in our system (see Section 5) the Three Phase, Four Wire mode is selected. For the DC measurement the Single Phase, Two Wire mode can be selected. Only Channel 1 is required and can be assigned to its own group if desired (Voltech Instruments Inc. 2009).

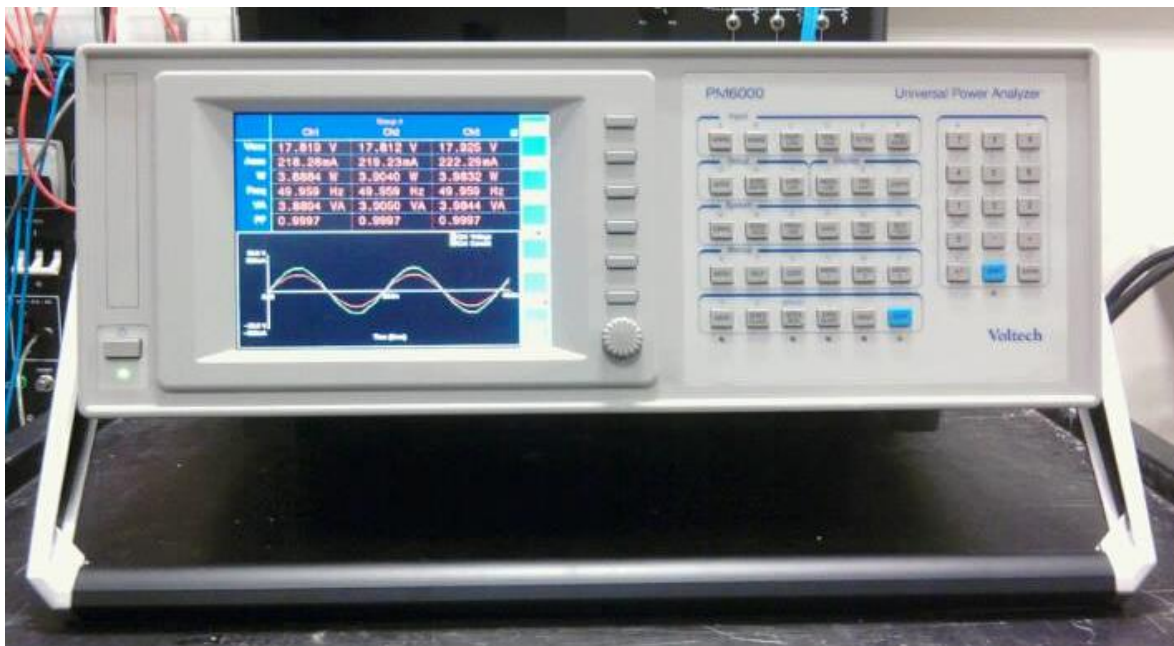

Figure 5 - Front view showing digital display with green and red sine waves indicating channel 1 current and voltage respectively

Range

Range settings are also applied to each group. A range is determined by the highest signal that can be measured. For instance, with a voltage range of 200V, a maximum voltage of +/- 200V can be measured. The range selected will depend on the type of shunt fitted. With Voltech shunts

connected the Power Analyser will select the correct setting automatically when switched on (Voltech Instruments Inc. 2009).

Coupling

By default the PM6000 is set to AC + DC coupling, allowing it to measure both AC and DC signals simultaneously. An AC only mode can be selected but is not necessary for this project since we are interested in performing both alternating and direct current measurements (Voltech Instruments Inc. 2009).

Scaling

Scaling is applied to measurements to change the scaled output of transducers so that the true measured currents are shown on the screen of the PM6000. Since Voltech shunts are being used in this project a scaling factor of 12.5 is automatically applied to the measured current (Voltech Instruments Inc. 2009).

Filter

By default a 2MHz filter is applied to each channel in the group which prevents signals with a higher frequency from being measured. A smaller bandwidth could be selected to help reduce noise in the measurements. As a guideline the user manual suggests a filter setting of 10 times the frequency of interest. 2kHz is the minimum setting available and because we are interested primarily in the fundamental frequency of the currents and voltages that are being measured this is the setting that was chosen (Voltech Instruments Inc. 2009).

Frequency

For the Power Analyser to accurately measure the RMS current, RMS voltage, power and so forth it needs to determine the fundamental frequency of the signal being measured. This eliminates the problem of noise being included in the measurements. By default, 'Volts' is the selected frequency source since the voltage waveform is not usually distorted during normal operation (Voltech Instruments Inc. 2009).

The 'Amps' setting can be chosen if the voltage waveforms are heavily distorted and the current waveforms are not. This could be the case if a pulse width modulated (PWM) motor drive is used for speed control due to the harmonic content produced by the drive, particularly at low rpms (Voltech Instruments Inc. 2009). This was found to be the case in this project when using a variable frequency drive (VFD) to control the motor under locked rotor conditions.

4.1.4 Setup

Mode

This menu allows the user to select the best operating mode for the waveform being measured. The default 'Normal' mode is suitable for most measurement applications. The Voltech continuously tries to detect the fundamental frequency of the voltage being supplied to the motor. The 'PWM Output' setting can also be chosen to analyse the output from motor drives when there is a fair amount of harmonic content. Using this mode, the data is sampled at high speed and the frequency of the motor is detected every few seconds using the voltage waveform. The analysis of the harmonics will take longer at lower motor frequencies. The PM6000 will analyse all of the requested harmonics before detecting the motor frequency. Hence, detection will be less frequent if the maximum number of harmonics to be analysed is increased. Once completed, the PM6000 will

attempt to show the modulated current and voltage waveforms at the motor frequency (Voltech Instruments Inc. 2009).

Integrator

The integrator feature can be used to determine the characteristics of a machine over time, such as an appliance which would draw a varying amount of power. This feature is not useful for this project and will not be needed (Voltech Instruments Inc. 2009).

Datalog

Data logging allows the user to record a set of results to the Power Analyser. 6MB of non-volatile flash memory is available for this and floppy disks can be inserted for additional storage. The user should take into consideration the amount of data they wish to store and also the rate at which measurements are taken (Voltech Instruments Inc. 2009).

4.1.5 Display

Features in the 'Display' menu allow the user to display certain information on the screen which by default isn't shown, such as peak voltage and current values, and the total harmonic distortion on a particular signal (Voltech Instruments Inc. 2009).

Using the Math feature measured parameters can also be used and manipulated to create new measurements. This is achieved by selecting the required measurements and using the 'Edit Function' option to create a new equation using the available operators. For more information on this feature refer to the user manual (Voltech Instruments Inc. 2009).

4.1.6 Establishing a connection to a Computer

Using the data logging capability measurements can be saved and accessed either using the menu or by establishing a connection with a computer or a network and downloading the data using Internet Explorer. An Ethernet connection can also be used for maintenance activities such as firmware upgrades (Voltech Instruments Inc. 2009).

Connecting directly to a PC as opposed to the local network should avoid conflicts with the IT department. A crossover cable can be used for making this connection. Steps are given below:

1. The cord should be plugged in to the correct socket and the Power Analyser should then be turned on.
2. A DOS window must then be opened on the PC.
3. After the DOS prompt appears type 'ipconfig /release' and then wait for it to return. Once the DOS prompt comes back the IP address displayed should be 0.0.0.0.
4. Next, type 'ipconfig /renew' and again wait for the DOS prompt to appear.
5. To view the connection simply type 'ipconfig' and the computer's IP address will appear. Add a value of one to the fourth number of the address unless the last number is 255. If this is the case then subtract one from the number. This new address will become the IP address of the Power Analyser.
6. Take note of the subnet mask, which in most cases is 255.255.0.0.
7. Using the Power Analyser's interface, navigate to the Ethernet menu and select 'Fix Settings'.

8. After this, enter the 'Fix Settings' submenu and set the IP address to the Power Analyser's new IP address determined in step 5. Also ensure that the subnet mask is the same as the computer's subnet mask (for example 255.255.0.0).
9. After this, leave the menu. If necessary turn off the computer's firewall to allow file transfer.
10. An Ethernet connection between the PC and the Power Analyser should now be established. To test this type 'ping' followed by the designated IP address at a DOS prompt. You should get several responses.
11. To open files and directories, simply open an internet browser and type the designated IP address in the address bar and then press enter.
12. If an Ethernet port was used that is usually used to connect to the local network, the user should connect to the network, open a new DOS prompt and type 'ipconfig /renew'. After this you should be back on the University network.

(Voltech Instruments Inc. 2009)

4.1.7 Specifications

The following tables contain information about the electrical ratings of the Power Analyser. In particular the maximum voltages and currents that can be measured directly by the unit are given (Table 3) as well as the voltage, frequency and magnitude of the power that must be supplied to the unit in order for it to properly function (Table 4). In addition, information is given about the dielectric strength of the inlets and outlets to the PM6000 (Table 5).

Electrical

Table 3 - Maximum voltage and current that can be measured continuously and over one second (Voltech Instruments Inc. 2009)

Measurement Channel	Max. Voltage for Continuous Measurements (V)	Max. voltage for 1 Second Measurements (V)	Max. Frequency (MHz)
Voltage Connections	2000	4000	10
Current Connections	2.5	50	10

Table 4 - Maximum and minimum ratings for power that can be supplied to PM6000 (Voltech Instruments Inc. 2009)

Line Input	Min	Max
Voltage (VAC)	90	264
Frequency Hz	47	63
Power (VA)	170	170

Table 5 - Dielectric strength of inputs and outputs (Voltech Instruments Inc. 2009)

Dielectric Strength	Voltage
Mains Supply Inlet (Live + neutral to	2.9kV DC

earth)	
Voltage Measurement	2kVpk
Current Measurement	2kVpk
Isolated supplies	2kVpk
30A Shunt	2kVpk

4.1.7.1 Measurement Accuracy

The user manual lists formulas for calculating the error in each measurement. The relevant formulas can be found in Section 8.6 of the User Manual (Voltech Instruments Inc. 2009).

4.2 Variable Frequency Drive

This chapter contains information about the design and operation of variable frequency drives (VFDs) and how they can be used for motor control. Also included are the electrical specifications for the VFD that has been used in this project during the locked rotor test described in Section 3.3.

4.2.1 Operation

Essentially, a variable frequency drive (VFD) is a motor controller that drives an AC machine by changing the frequency f of the current that is supplied to the motor (Energy Management Corporation 2014). The synchronous speed N_s of the machine is directly proportional to f as per the following equation:

$$N_s = 120f/p \tag{22}$$

Where N_s is in rpm and p is the number of poles in the stator winding.

Also known as frequency inverters, or variable speed drives (VSDs), VFDs generally work by first rectifying the incoming AC voltage into DC and then generating a series of pulses from the DC voltage to simulate a sinusoidal waveform at the desired frequency (see Figure 6). The most common method for doing this is to run a sine wave and a triangle wave through a comparator, generating a pulse when the value of the triangle wave is less than the value of the sine wave. This is achieved by using insulated gate bipolar transistors (IGBTs), however silicon controlled rectifiers (SCRs) can be used as well (Novak 2009).

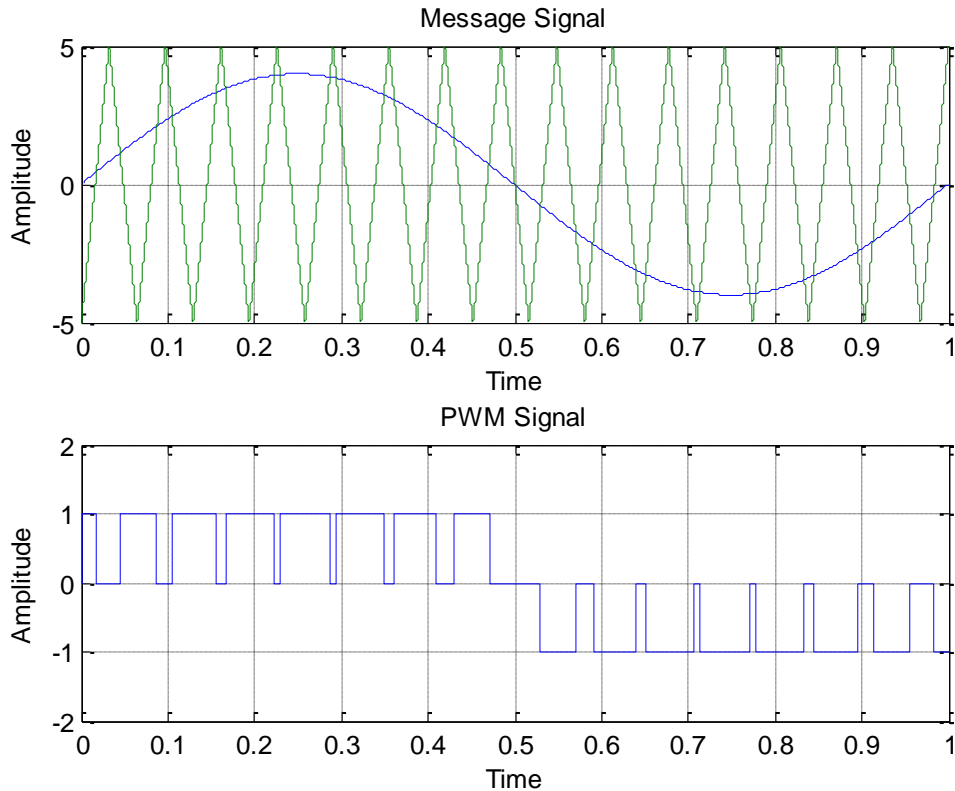

Figure 6 - Diagram showing triangle and sine waves placed through a comparator to generate the pulse width modulated output signal

The VFD also increases the output voltage in proportion to the supply frequency in order to maintain a fixed voltage to frequency (V/f) ratio. It is necessary to do this so that the motor can produce enough torque to keep running. Voltage control is achieved by varying the duty cycle of the modulated voltage waveform (Natural Resources Canada 2014).

The frequency conversion process is not 100% efficient as 2% to 3% of the input power is converted to heat inside the VFD. Furthermore, the process can cause overvoltage spikes and harmonic distortion in the current (Energy Management Corporation 2014). These distortions are significantly increased when operating from a single phase supply and particularly so on single wire earth return systems. Fortunately there are several things that can be done to eliminate this problem. The easiest method is to place a filter either side of the drive. Another method is to connect capacitors to a common bus which act as a short circuit, causing the harmonics to travel through the capacitors to ground. If the harmonics are not removed on the line side of the drive, overheating and crosstalk can occur, where the distortion in one circuit interferes with other circuitry (Energy Management Corporation 2014)

Pulse width modulated VFDs are widely used in industry since they have a high input power factor due to a fixed DC bus voltage, there is no motor cogging (magnetic locking between the stator and the rotor) and they are generally very efficient and low cost. The other two major types are voltage source inversion (VSI) drives and current source inversion drives (CSI) which are known to cause motor cogging below 6Hz (Energy Management Corporation 2014).

As shown in Figure 7, a simple topology for a VFD includes a diode bridge converter, a smoothing capacitor, a filter and an inverter, as well as additional control circuitry for achieving the desired frequency (Polka 2001).

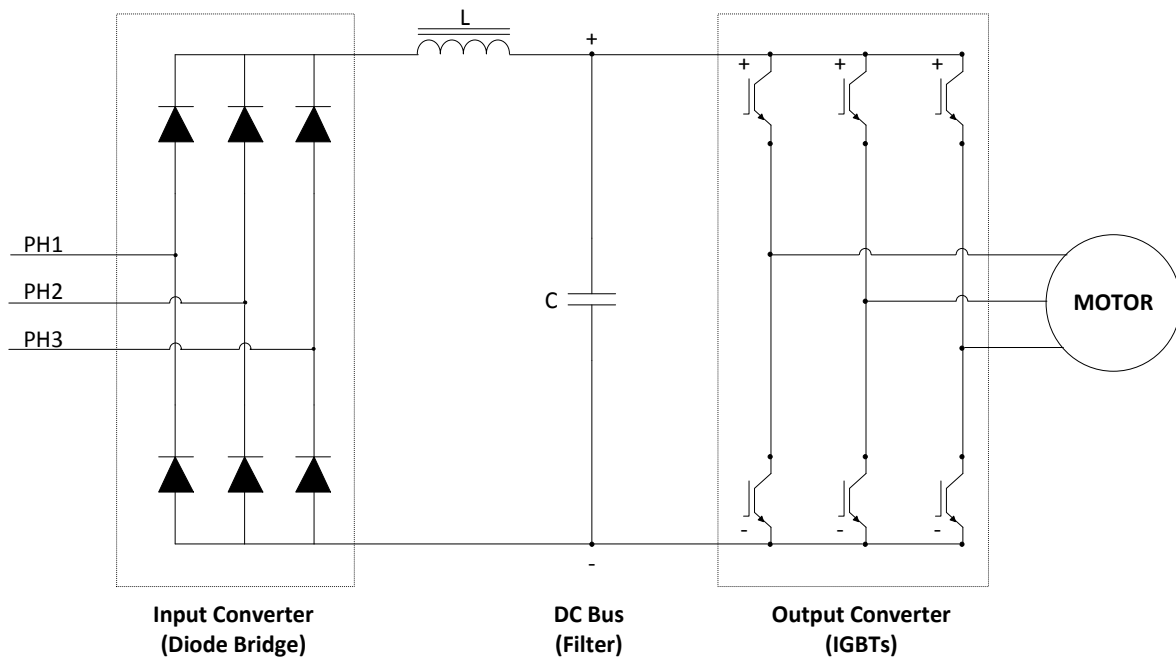

Figure 7 - Circuit diagram for a PWM VFD

The converter consists of six diodes connected in a full-wave bridge configuration, allowing current flow in one direction after the rectification. When phase 1's voltage is higher than the voltage on phases 2 and 3, the corresponding diode conducts a current. When phase 2 becomes more positive than phase 1, then phase 1's diode does not conduct. This is also the case for the diodes on the negative side of the bus. This results in a series of pulses as each diode opens and closes (Amick, Avery and Amer 2010).

In order to smoothen the voltage waveform from the converter so that it is as close as possible to a DC voltage, a capacitor is placed in parallel with the converter. Typically this reduces the ripple to less than 3V, but it can be affected by factors such as the voltage level of the AC line feeding into the drive, any unbalance on the three input phases, filters on the drive and so on (Amick, Avery and Amer 2010).

The third and final primary section of the main power circuit is the inverter. This section is comprised of the IGBTs which are triggered to switch on and off in such a way that the output phases are lagging each other by 120 degrees. The rate at which the transistors are gated or turned on usually ranges between 2 to 15kHz. Higher carrier frequencies yield smoother current waveforms but also greater VFD losses (Amick, Avery and Amer 2010).

It should be noted that there is a phase shift between current and voltage waveforms due to the inductance in the connected motor. Harmonic distortion in the current is reduced using a line reactor/inductor, which is essentially a conductor coiled around a magnetic core. When current flows through the core a magnetic field is established and sudden changes in current amplitude or direction are opposed by the magnetic field which could be caused by the harmonic content. The

inductance in the attached system is what causes the current to appear sinusoidal in nature due to its power filtering characteristics (Amick, Avery and Amer 2010).

Figure 8 shows additional features such as the V/f control circuitry and a speed reference. In most cases the 'speed reference' is just a set point. In more complex situations, the 'speed reference' might come from a process controller, such as a tachometer or a PLC (Amick, Avery and Amer 2010).

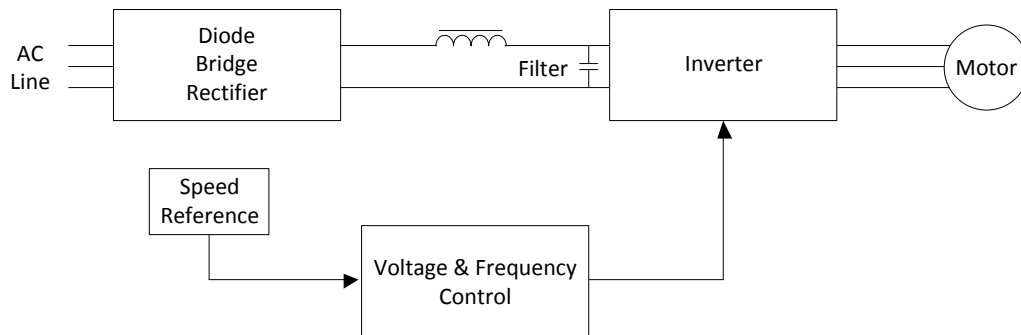

Figure 8 - Block diagram for a typical Variable Frequency Drive

4.2.2 Specifications

The motor drive used in this project was developed by SEW Eurodrive and is a 0S model from the Movitrac 07 series (see Figure 9). 0S indicates the size of this unit in terms of its power rating, and is one of the smallest available.



Figure 9 - Isometric view of the unit which is rated for 0.37kW AC machines

Table 6 contains information about the operating specifications of the VFD. Most importantly, it gives the voltage, current and frequency of the power that must be supplied to the drive in order for

it to properly function. Also given in this table is the voltage, current and power produced by the unit.

Table 6 - Electrical and temperature specifications for the Movitrac 07 unit (SEW Eurodrive 2003)

Model		MC07A004-2B1-4-00
Input (Single Phase)	Voltage (V)	200 – 240
	Current (A)	6.1
	Frequency (Hz)	50 – 60
Output (Three Phase)	Voltage (V)	0 - V_{in}
	Current (A)	2.5
	Power (kW)	0.37
IP Rating	20	
Temp (°C)	10 – 50	

4.3 Toshiba Motor

This section contains technical information about the Toshiba motor, in particular, its electrical specifications and other important design information. Also provided are notes on what the numbers and letters on the motor’s nameplate actually mean and what these indicate about its performance characteristics.

4.3.1 Specifications

Nameplate Data.

Table 7 - Nameplate information for the Toshiba motor (Toshiba International Corporation n.d.)

The following information was taken directly from the induction motor itself. Because of the age of this particular model it was not possible to find further technical details in the catalogue available on Toshiba’s website.

Rated Power (kW)	0.37kW	Model	TSH01
Rated Voltage (V)	415	Compliance	AS1359
Rated Current (A)	1.1	Design Class	N
Power Factor (100% Load)	0.65	Insulation Class	F
Frequency	50Hz	Frame	D71
No. of Poles	4	IP Rating	56
Stator Connection	Wye	Duty Cycle Rating	S1
Rated Speed (rpm)	1410	Mass (kg)	16

Notes on Specifications

Design Class

The performance characteristics of a motor will depend on the motor windings and the rotor design. The International Electrotechnical Commission (IEC) and the National Electrical Manufacturers Association (NEMA) have designated specific designs of general purpose motors using letters. IEC Design Class N is equivalent to NEMA Design Class B and is the most common industrial motor design. These motors have normal starting torques and low starting currents. They have adequate locked rotor torque to start in a number of different industrial applications (Bhatia n.d.).

Insulation Class

The Insulation Class is an industry standard that refers to the thermal tolerance of a motor's windings. It is based on adding the operational heat and the ambient temperature of the motor together. Class F indicates the motor has an operating life of approximately 20,000 hours at 155°C (Bhatia n.d.).

Frame

Most motor dimensions are standardized and are usually associated with a specific number and letter designation. The letter usually indicates the type of mounting and the number is the height from the centre of the shaft to the base of the motor. The motor's dimensions can be found by looking up the number/letter designation from an IEC/NEMA motor dimensions chart (Pontiac Electric Motors and Drives n.d.). For example, using the IEC system, D71 indicates a flange mount with a shaft height of 71mm (Bhatia n.d.).

IEC uses IP Ratings to indicate the level of protection provided by the motor's enclosure. An IP56 rating indicates complete protection from dust and flooding of water (Bhatia n.d.).

Duty Cycle Rating

The IEC uses eight duty cycle designations to describe the operating conditions of an electrical motor. S1 refers to 'Continuous duty', which means the motor operates at a fixed load, long enough for it to reach temperature equilibrium (The Engineering Toolbox 2014).

4.4 Leroy Somer Motor

This section contains technical information about the Leroy Somer motor used in this project. In particular, its electrical specifications and other important design information is given.

4.4.1 Specifications

Table 8 - Nameplate information for the Leroy Somer motor (Leroy Somer n.d.)

From Table's 7 and 8 we find that the electrical characteristics of both motors are quite similar in comparison. In particular both have a power and voltage rating of 0.37kW and 415V respectively, a similar rated current and rated speed, and both feature a wye connected stator.

Rated Power (kW)	0.37	Model	Mot3 AS712-4
Rated Voltage (V)	415	Compliance	AS1359
Rated Current (A)	1.02	Design Class	A
Power Factor (100% Load)	0.75	Insulation Class	F
Frequency	50Hz	IK Rating	08
No. of Poles	4	IP Rating	55
Stator Connection	Wye	Duty Cycle Rating	S1
Rated Speed (rpm)	1375	Mass (kg)	6.4

Notes on Specifications

IK Rating

The IK rating comes from the European standard EN62262. It defines the type of protection that is provided by enclosures of electrical equipment against dust, moisture, solid objects and other

external mechanical impacts. Specifically, an IK rating of 08 indicates the motor enclosure is made of steel, has a mass of approximately 0.5kg and has undergone a variety of impact tests.

(British Standards Institution 1995).

5 System Design

Section 5 contains wiring diagrams for each of the three parameter tests conducted. These wiring configurations allow any wye or delta connected motor to be attached to the system, provided it operates within the specified ratings of the other connected equipment. Note that where HI and LO are written these points correspond to the input and output terminals of each channel on the back of the Voltech PM6000.

5.1 System Schematics

Figures 10 to 12 indicate where leads are connected between each piece of equipment and Figure 13 provides a close up view of the connections that are made to and from the Power Analyser so that phase currents, voltages and power drawn by the motor of interest can be measured. Internal circuitry of the equipment itself has not been provided but can be found in the relevant user manuals if necessary.

DC Analysis

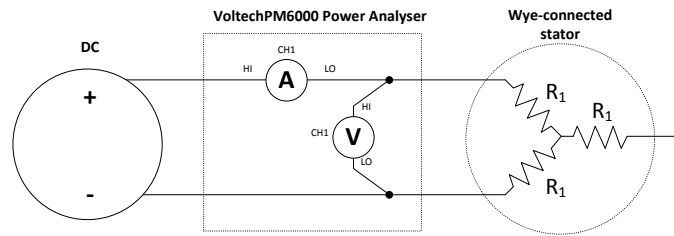

Figure 10 - Wiring Configuration for DC test

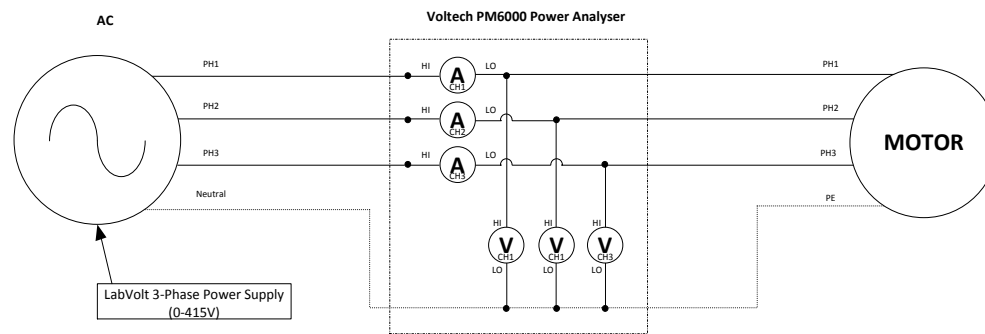

Figure 11 - Wiring Configuration for no load test

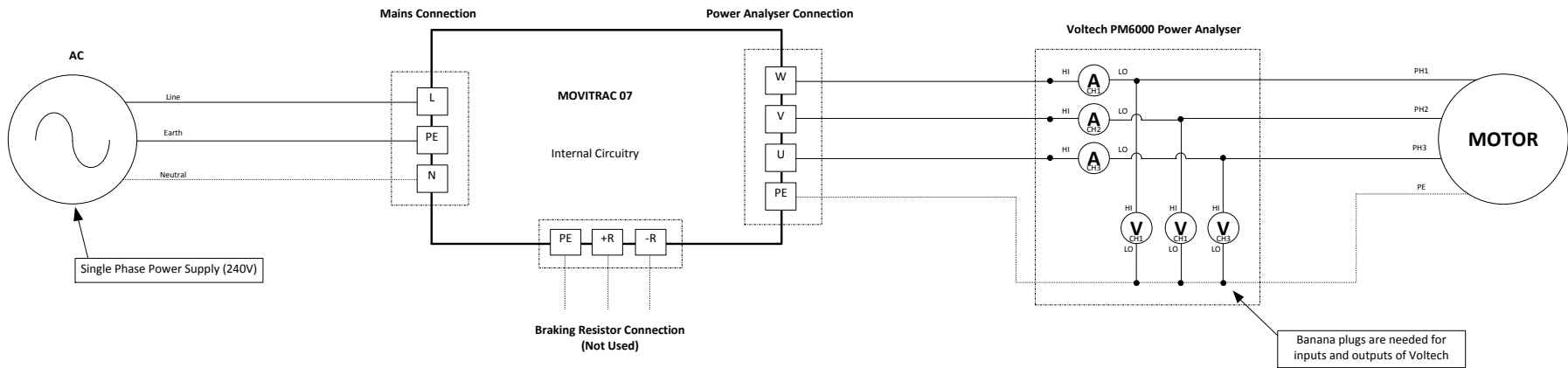

Figure 12 - Wiring Configuration for the locked rotor test

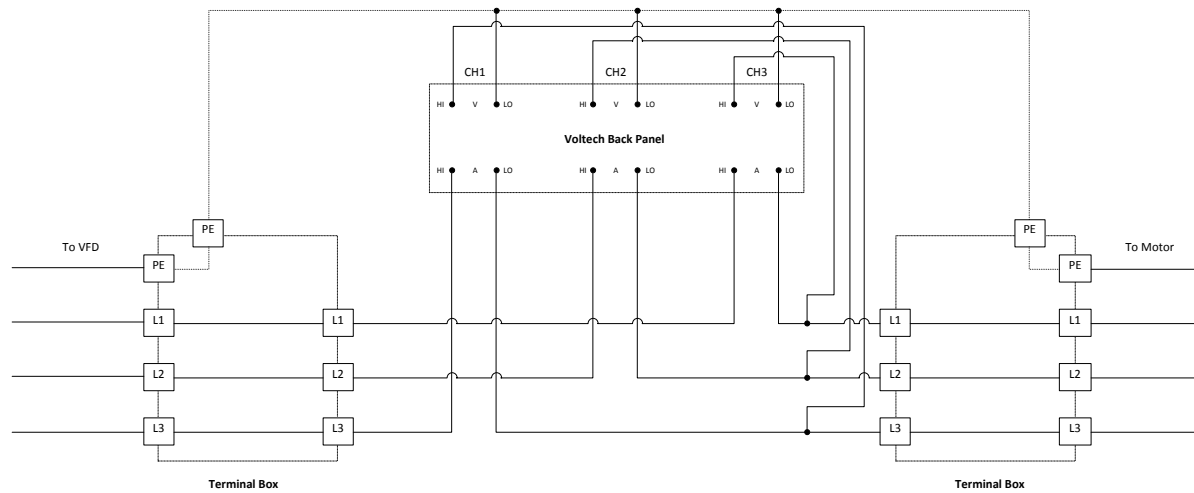

Figure 13 - Connections to Power Analyser

5.2 Australian Wiring Standards

When building and testing the system proposed in this report it is important that the equipment and wiring conforms to the guidelines laid out in *AS/NZS 3000 Wiring Rules – 2007, Electrical Installations*. Appropriate safety measures should be in place to protect persons working on or near the equipment at all times (Standards Australia 2007). The following information is a paraphrased summary of some of the key wiring and safety information provided in this particular standard, which can be accessed via the SAI Global Database.

AS/NZS 3000: 1.5.3 Protection against Electric Shock

The system must be provided with protection against electric shock which may arise from touching parts that become live during fault conditions (indirect contact) or parts that are live during normal operation (direct contact).

In section 1.5.4.2 of the Wiring Rules it is stated that methods of protection against electric shock arising from direct contact may include:

- Insulation, as per Section 1.5.4.3.
- Barriers or enclosures, as per Section 1.5.4.4.
- Obstacles, as per Section 1.5.4.5.
- Placing live parts out of reach, as per Section 1.5.4.6.

Protection against electric shock arising from indirect contact may include:

- Devices that automatically disconnect the power supply when a fault occurs that is likely to cause a current flow through a person touching exposed conductive parts
- Devices that limit the amount of fault current that can pass through a person to a level that is safe

(Standards Australia 2007)

AS/NZS 3000: 1.5.6 Residual Current Devices (RCDs)

RCDs are designed to switch off the supply when current leaking to earth is detected at harmful levels and offer protection against electric shock. Note that by themselves they are not recognized as an adequate method of protection against live parts but can be used in addition to the methods listed above. RCDs should be installed in order to protect circuits, power outlets, lighting, hand held equipment and other electrical installations as specified in AS/NZS 3001, AS/NZS 3002, AS/NZS 3003, AS/NZS 3004, AS/NZS 3012 and AS/NZS 4249 (Standards Australia 2007).

AS/NZS 3000: 1.5.8 Protection against Thermal Effects

The electrical equipment used must be installed and operated so that the temperature characteristics of the equipment do not cause damage to the installation or any other installation, either electrical or otherwise. In particular, equipment should not be operated outside its specified operating region, unless advised otherwise, to prevent overheating. Where heat is generated during normal operation, equipment should be adequately ventilated in order to maintain an operating temperature below the specified or rated limit of the equipment (Standards Australia 2007).

AS/NZS 3000: 1.5.9 Protection against Overcurrent

Overcurrent protection must be in place which either disconnects the supply before the overcurrent reaches a dangerous value, or which limits the maximum overcurrent to a safe value and duration (Standards Australia 2007).

AS/NZS 3000: 1.5.10 Protection against Earth Faults

Parts of the system intended to carry an earth fault current (such as protective earthing conductors) must be capable of carrying the current without overheating (Standards Australia 2007).

AS/NZS 3000: 1.5.11 Protection against abnormal voltages

Protection must be provided against harmful voltages which may arise from a fault between live parts of circuits and so on (Standards Australia 2007).

AS/NZS 3000: 1.5.13 Protection against injury from moving mechanical parts

Protection must be provided against injury from mechanical movement of electrically actuated equipment (for example, motors should be fully enclosed so that fingers cannot be caught inside the rotor etc.) (Standards Australia 2007).

AS/NZS 3000: 1.5.14 Protection against external influences

All parts of the system should be sufficiently protected against damage that could arise from environmental and other external influences that the system could be exposed to during normal operation (Standards Australia 2007).

AS/NZS 3000: 1.6 Design of an Electrical Installation

Characteristics of the electrical installation shall be determined as per Section 1.6 of *AS/NZ 3000* (Standards Australia 2007).

AS/NZS 3000: 1.7 Selection and Installation of Electrical Equipment

Electrical equipment which forms part of the system must be selected and installed to:

- Operate safely during normal operating conditions; and
- Not cause a danger from electric shock, physical injury, high temperature or fire in the event of reasonably expected conditions of abnormal operation, overload, fault or external influences that may apply in the electrical installation; and
- Be installed in accordance with the manufacturer's instructions

(Standards Australia 2007)

Further information on the General Arrangement of Electrical Equipment, Control and Protection

AS/NZS 3000: 2.2.1.2 Common Neutral

Each three phase and single phase part of the system which requires a neutral conductor in order to operate must have one. A neutral conductor can be used for multiple circuits originating from the same supply subject to the following conditions:

- The continuity of the common neutral conductor must not depend on connections at the terminals of electrical equipment, including control switches.
- Sub-circuits that have a common neutral must be controlled and protected by linked switches or linked circuit breakers.
- The neutral conductor must be marked at switchboards to identify the associated active conductors.

(Standards Australia 2007)

AS/NZS 3000: 2.2.3 Selection and installation of conductors

AS/NZS 3000: 2.2.4.2 Voltage

The voltage rating of electrical equipment must be adequate for the nominal voltage of the system to which it is connected (Standards Australia 2007).

AS/NZS 3000: 2.2.4.3 Current

Each item of electrical equipment must be selected and installed to be suitable for:

- The design current, taking into consideration any inductive, capacitive and harmonic effects; and
- The current likely to flow through the system during abnormal conditions for such periods of time as are determined by the characteristics of the protective devices concerned.

(Standards Australia 2007)

AS/NZS 3000: 2.2.4.4 Frequency

If frequency has an effect on the characteristics of electrical equipment, the rated frequency of electrical equipment must correspond to the nominal frequency of the power supply to which the system is connected (Standards Australia 2007).

AS/NZS 3000: 2.2.4.5 Power

Each item of electrical equipment selected on the basis of its power characteristics shall be suitable for the duty demanded of the electrical equipment (Standards Australia 2007).

AS/NZS 3000: 2.2.4.6 Effects on operator or other equipment

Each item of electrical equipment shall be selected and installed so that, providing it is maintained, it will not cause harm to an operator or harmful effects to other equipment or impair the supply during normal service including switching operations (Standards Australia 2007).

6 Results

This section discusses the results from the three tests performed on each induction motor as per Section 3. From this data the motor parameters were determined and then used to generate a torque speed curve in Matlab, which can then be compared with measured torque values to verify that the calculated motor parameters are correct.

It should be noted that these results cannot be 100% accurate. Certain factors which could influence the accuracy of the data can include calibration error of the instruments, in particular the Power Analyser, and also the internal resistance of the cables was not taken into consideration, although this was thought to be negligible and thus shouldn't have a significant impact on the end results. Something which may have a more noticeable impact on the end results is a temperature increase in the motor windings, although care was taken to run the motor for as short a time as possible, and to allow it to cool down to the ambient temperature before performing another test.

6.1 Toshiba Motor

The locked rotor test has been performed at full rated frequency and at a reduced frequency because of certain issues that arose when the VFD was used. These issues are described in detail below. All currents and voltages are RMS values unless otherwise specified.

The data in Table 9 is for the locked rotor test performed at the full rated frequency. The measured values look fairly consistent across all phases. The total harmonic distortion (THD) in the current and voltage waveforms is well within the 5% limit recommended by IEEE in Section 3.1.2 of Standard 112. The power drawn by the motor is quite low, much lower than the 370W rating, so there is little chance that the windings would overheat during the experiment.

Table 9 - Data from the locked rotor test performed using the 50Hz Lab-Volt power supply

Locked Rotor Test – Trial 1	Ch1	Ch2	Ch3	Average
V_{rms} (V)	59.709	59.828	58.179	59.23867
A_{rms} (A)	1.1067	1.1333	1.1240	1.121333
Real Power (W)	40.298	41.174	40.511	40.661
Complex Power (VA)	66.082	67.802	65.395	66.42633
Frequency (Hz)	49.969	49.969	49.969	49.969
Power Factor	0.6098	0.6073	0.6195	0.6122
V_{THD} (%)	1.8770	1.7413	1.6668	1.7617
A_{THD} (%)	1.6080	1.4015	1.5921	1.533867

When performing the test at the reduced rotor frequency the amount of reactive power drawn by the motor is significantly higher than before since the inductive reactance is lower. This is because X_L is proportional to f . In this case, the harmonic distortion on the current waveforms exceeds the recommended 5% maximum, but the distortion on the voltage waveforms is exceptionally large (greater than 100%), as shown in Table 10.

Table 10 - Data from the locked rotor test performed at reduced frequency using the VFD

Locked Rotor Test – Trial 2	Ch1	Ch2	Ch3	Average
V_{rms} (V)	216.84	216.38	216.80	216.6733
A_{rms} (A)	1.0948	1.0643	1.0794	1.0795

Real Power (W)	31.317	29.459	30.320	30.36533
Complex Power (VA)	237.39	230.29	234.01	233.8967
Frequency (Hz)	4.8228	4.8228	4.8228	4.8228
Power Factor	0.1318	0.1279	0.1295	0.129733
V_{THD} (%)	100.18	105.02	106.76	103.9867
A_{THD} (%)	15.986	15.988	17.357	16.44367

At first glance the large %THD does not make much sense but it is likely that this value is determined by comparing the voltage and current signals using current as a reference phasor. Since the voltage is not sinusoidal in nature like the current but instead exhibits square wave properties the Power Analyser decides that the voltage is highly distorted. Conversely, using the voltage as the reference phasor V_{THD} becomes quite small and A_{THD} exceeds 100%. The results suggest that the quality of the power coming from the motor drive is quite poor and a filter might be needed to clean up the waveforms.

Another cause for concern is that the voltages recorded in Table 10 are different from the voltages that were measured using a UNI-T Multimeter, and yet both the Power Analyser and the multimeter were measuring the same RMS values. When the output voltage of the VFD was increased to the maximum possible value using the speed control knob on the unit, the reading given by the multimeter was 240V (the rated value of the drive) and the reading given by the PM6000 was less than this. This might suggest the PM6000 has difficulty measuring the PWM signal from the motor drive because if a sinusoidal power supply is used instead of the VFD the measurements from both devices match exactly.

In conclusion, the data in Table 10 is probably not reliable. When the motor parameters were calculated using this data the magnetizing reactance X_M was negative. Because of this, and based on the observations above, it is likely that the voltages measured by the Power Analyser were in error.

Table 11 shows that when the motor was run unloaded the power factor on the first phase was about 30% lower than the power factor on the other two phases, suggesting that the inductance was higher on the first phase and that perhaps the rotor is not uniformly wound. If necessary, capacitors could be used to correct this and improve the overall efficiency of the machine. The only cause for concern would be if the voltages on each phase were unbalanced which could cause overheating and affect performance characteristics such as the locked rotor torque.

Table 11 - No load test data

No Load Test	Channel 1	Channel 2	Channel 3	Average
V_{rms} (V)	240.42	241.79	240.22	240.81
A_{rms} (A)	0.694	0.689	0.714	0.699
Real Power (W)	13.648	20.591	18.023	17.42067
Complex Power (VA)	166.82	166.70	171.58	168.3667
Frequency (Hz)	50.020	50.020	50.020	50.02
Power Factor	0.0818	0.1235	0.1050	0.103433

In Table 12 the readings from Channel 1 and Channel 2 are quite similar. One of the disadvantages of doing the DC analysis across only two stator terminals is that we ignore the stator resistance on phase three, so if the test had been done on the third stator terminal as well this would have led to a

slightly more accurate approximation of the average per-phase stator resistance. One of the limitations of the test is that unless we can pull apart the motor and measure the stator test temperature it is not possible to correct R_1 to what it would be during normal operation.

Table 12 - DC test data

DC Test	Channel 1	Channel 2	Average
V_{rms} (V)	15.234	15.088	15.161
A_{rms} (A)	1.1293	1.1326	1.13095
Real Power (W)	16.779	16.768	16.7735
Complex Power (VA)	17.218	17.104	17.161
Frequency (Hz)	0.0000	0.0000	0.0000
Power Factor	0.9745	0.9803	0.9774

It seems a little odd that the measured power factor is not exactly one, because a DC voltage does not vary with time, so there can be no phase displacement in the current waveform and therefore the current could not be lagging the voltage. This suggests that there must still be some AC signal flowing through the system which is very small and will not have much of an effect on the results.

6.1.1 Calculations

Note that the calculation procedure used below differs from the method presented in Section 3. This procedure has been used instead of the method proposed in Chapman 2003 because it assumes that the locked rotor test was performed at 50Hz and not at a reduced operating frequency, although both approaches yield similar results. The calculations below follow the procedure provided in Chan and Shi 2011.

DC Test

$$2R_1 = \frac{V_{DC}}{I_{DC}} \quad (23)$$

$$\begin{aligned} \therefore R_1 &= \frac{V_{DC}}{2I_{DC}} \\ &= \frac{15.161}{2 \times 1.13095} \\ &= 8.573\Omega \end{aligned}$$

No Load Test

$$\begin{aligned} Q_1 &= \sqrt{(V_1 I_1)^2 - P_1^2} \quad (24) \\ &= \sqrt{(240.81 \times 0.699)^2 - 17.421^2} \\ &= 167.422VAr \end{aligned}$$

$$X_{nl} = \frac{Q_1}{I_1^2} \quad (25)$$

$$= \frac{167.422}{0.699^2}$$

$$= 342.656\Omega$$

Because $s \approx 0$,

$$X_{nl} \approx X_1 + X_M \quad (26)$$

Determining Losses

$$P_{in} = P_{SCL} + P_{core} + P_{misc} \quad (27)$$

$$= 3I_1^2 R_1 + P_{rot}$$

$$3 \times 17.421 = 3 \times 0.699^2 \times 8.573 + P_{rot}$$

$$52.263 = 12.566 + P_{rot}$$

$$\therefore P_{rot} = 39.697W$$

Locked Rotor Test Performed at 50Hz

Here two new quantities are introduced which were not mentioned previously in Section 3.3, namely R_x and X_x . In Section 3.3, the calculations assume that under locked rotor conditions the equivalent circuit is essentially a series combination of R_1 , X_1 , R_2 and X_2 , and R_c and X_M are ignored. In the following calculation procedure X_M is taken into consideration and the two parallel branches in the circuit containing jX_M , and $R_2 + jX_2$ respectively are combined, producing R_x and X_x as shown in Figure 14.

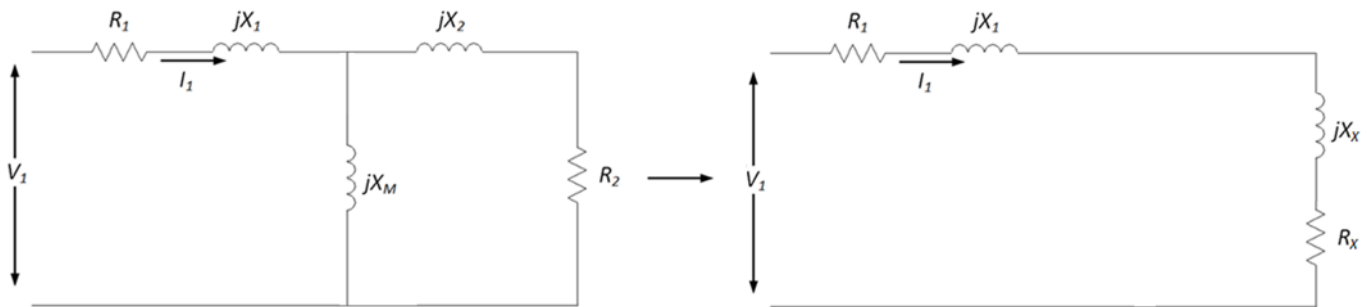

Figure 14 - Circuit diagram showing parallel branches combined to produce a simplified series circuit

$$Q_1 = \sqrt{(V_1 I_1)^2 - P_1^2} \quad (28)$$

$$= \sqrt{(59.239 \times 1.121)^2 - 40.661^2}$$

$$= 52.503VAr$$

$$X_{LR} = \frac{Q_1}{I_1^2} \quad (29)$$

$$= \frac{52.503}{1.121^2}$$

$$= 41.780\Omega$$

For a Class B motor,

$$X_1' = 0.4X_{LR} \quad (30)$$

$$= 0.4 \times 41.780$$

$$= 16.712\Omega$$

$$X_2' = 0.6X_{LR} \quad (31)$$

$$= 0.6 \times 41.780$$

$$= 25.068\Omega$$

From the no load test,

$$X_{nl} = 342.656\Omega$$

Hence,

$$X_M = X_{nl} - X_1 \quad (32)$$

$$X_M = 342.656 - 16.712$$

$$X_M = 325.944\Omega$$

$$R = \frac{P_1}{I_1^2} \quad (33)$$

$$R_{LR} = \frac{40.661}{1.121^2}$$

$$R_{LR} = 32.357\Omega$$

$$R_X = R - R_1 \quad (34)$$

$$R_2 = 32.357 - 8.573$$

$$R_2 = 23.784\Omega$$

$$R_X + jX_X = \frac{(R_2 + jX_2') \times jX_M}{(R_2 + jX_2') \times jX_M} \quad (35)$$

$$R_X \approx \frac{R_2 \times jX_M^2}{(R_2 + jX_2') \times jX_M} \quad (36)$$

$$R_2 = R_X \times \left(\frac{X_2' + X_M}{X_M} \right)^2 \quad (37)$$

$$R_2 = 23.784 \times \left(\frac{25.068 + 325.944}{325.944} \right)^2$$

$$R_2 = 27.582\Omega$$

In Summary, the per phase resistance and reactance in the motor is

$$X_M = 325.944\Omega$$

$$X_1 = 16.712\Omega$$

$$X_2 = 25.068\Omega$$

$$R_1 = 8.573\Omega$$

$$R_2 = 27.582\Omega$$

6.1.2 Torque speed characteristics

Figure 15 was generated using a Matlab script (see Appendix) 1 and is based on the calculated parameter values. One of the limitations of the program is that it does not take into account the mechanical losses of the motor. Taking these losses into account the maximum rotor speed would be marginally lower than 1500rpm (i.e. closer to the value stated on the motor's nameplate). The shape of this curve is typical of a motor with a high stator resistance.

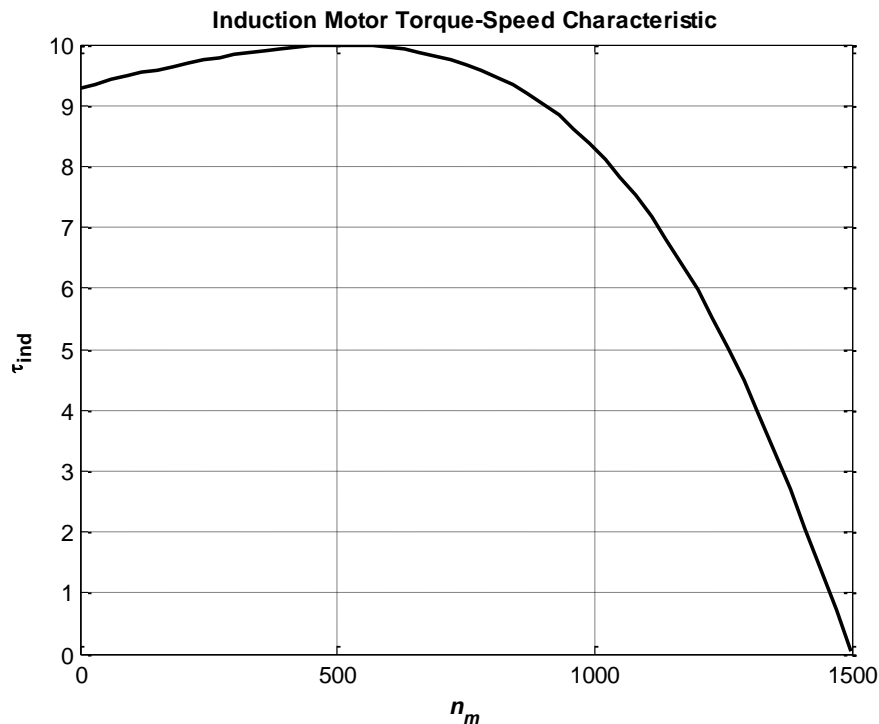

Figure 15 - Simulated torque-speed curve for the Toshiba induction motor

6.2 Leroy Somer Motor

Again, a locked rotor test was performed at full rated frequency (see Table 13) and at a reduced frequency and the same problem arose where the calculated value for X_M was negative when values from Trial 2 (see Table 14) were used. As such, this data in this table is probably not reliable.

Table 13 shows that by using the Lab-Volt equipment to power the motor the harmonic distortions in the voltage and current waveforms are well below the 5% limit specified by IEEE. There does not seem to be any anomalies in the data.

Table 13 - Data from the locked rotor test performed using the 50Hz Lab-Volt power supply

Locked Rotor Test – Trial 1	Channel 1	Channel 2	Channel 3	Average
V_{rms} (V)	61.940	60.172	61.615	61.24233
A_{rms} (A)	1.0422	1.0018	1.0231	1.022367
Real Power (W)	48.165	44.739	45.454	46.11933
Complex Power (VA)	64.553	60.279	63.035	62.62233
Frequency (Hz)	49.982	49.982	49.982	49.982
Power Factor	0.7461	0.7422	0.7211	0.736467
V_{THD} (%)	1.7649	1.7542	2.0272	1.848767
A_{THD} (%)	0.4901	0.4725	0.5522	0.504933

The data in Table 14 is for a locked rotor test performed at a reduced frequency using the VFD. Again we find that the power factor decreases and the reactive power drawn by the motor increases substantially compared to when the 50Hz Lab-Volt supplies is used.

Table 14 - Data from the locked rotor test performed at reduced frequency using the VFD

Locked Rotor Test – Trial 2	Channel 1	Channel 2	Channel 3	Average
V_{rms} (V)	216.45	216.04	216.40	216.2967
A_{rms} (A)	1.0945	1.0934	1.0922	1.093367
Real Power (W)	45.902	45.640	45.818	45.78667
Complex Power (VA)	236.89	236.23	236.36	236.4933
Frequency (Hz)	6.5010	6.5010	6.5010	6.501
Power Factor	0.1937	0.1932	0.1938	0.193567
V_{THD} (%)	190.75	167.26	144.77	167.5933
A_{THD} (%)	0.8773	0.8875	0.7962	0.853667

In Table 15 it can be seen that even when the motor is run unloaded a large amount of current is drawn. The real power drawn on the first phase (Channel 1) is also less than that of the other two phases resulting in a slightly smaller power factor on phase one.

Table 15 - No load test data

No Load Test	Channel 1	Channel 2	Channel 3	Average
V_{rms} (V)	240.78	239.56	238.71	239.6833
A_{rms} (A)	0.899	0.882	0.906	0.895667
Real Power (W)	40.268	43.015	45.256	42.84633
Complex Power (VA)	216.58	211.28	216.27	214.71
Frequency (Hz)	50.000	50.000	50.000	50.000
Power Factor	0.1859	0.2036	0.2093	0.1996

Again, for the Leroy Somer Motor, the DC Test was performed across only two stator terminals, which would have marginally affected the accuracy of the calculated theoretical stator resistance.

Table 16 - DC test data

DC Test	Channel 1	Channel 2	Average
V_{rms} (V)	25.182	25.214	25.198
A_{rms} (A)	1.023	1.019	1.021

Real Power (W)	25.374	25.421	25.3975
Complex Power (VA)	25.752	25.700	25.726
Frequency (Hz)	0.000	0.000	0.000
Power Factor	0.9853	0.9822	0.98375

6.2.1 Calculations

Again, the calculations are based on the method described in Chan and Shi 2011.

DC Test

$$2R_1 = \frac{V_{DC}}{I_{DC}} \quad (38)$$

$$\begin{aligned} \therefore R_1 &= \frac{V_{DC}}{2I_{DC}} \\ &= \frac{25.198}{2 \times 1.021} \\ &= 12.340\Omega \end{aligned}$$

No Load Test

$$\begin{aligned} Q_1 &= \sqrt{(V_1 I_1)^2 - P_1^2} \quad (39) \\ &= \sqrt{(239.683 \times 0.896)^2 - 42.846^2} \\ &= 210.438 \text{Var} \end{aligned}$$

$$\begin{aligned} X_{nl} &= \frac{Q_1}{I_1^2} \quad (40) \\ &= \frac{210.438}{0.896^2} \\ &= 262.125\Omega \end{aligned}$$

Because $s \approx 0$,

$$X_{nl} \approx X_1 + X_M \quad (41)$$

Determining Losses

$$P_{in} = P_{SCL} + P_{core} + P_{misc} \quad (42)$$

$$= 3I_1^2 R_1 + P_{rot} \quad (43)$$

$$3 \times 42.846 = 3 \times 0.896^2 \times 12.340$$

$$128.538 = 29.720 + P_{rot}$$

$$\therefore P_{rot} = 98.818W$$

Locked Rotor Test Performed at 50Hz

$$Q_\phi = \sqrt{(V_1 I_1)^2 - P_1^2} \quad (44)$$

$$= \sqrt{(61.2433 \times 1.022)^2 - 46.119^2}$$

$$= 42.316 \text{Var}$$

$$X_{LR} = \frac{Q_1}{I_1^2} \quad (45)$$

$$= \frac{42.316}{1.022^2}$$

$$= 50.514 \Omega$$

For a Class B motor,

$$X_1' = 0.4X_{LR} \quad (46)$$

$$= 0.4 \times 50.514$$

$$= 20.206 \Omega$$

$$X_2' = 0.6X_{LR} \quad (47)$$

$$= 0.6 \times 50.514$$

$$= 30.308 \Omega$$

From the no load test,

$$X_{nl} = 262.125 \Omega$$

Hence

$$X_M = X_{nl} - X_1 \quad (48)$$

$$X_M = 262.125 - 20.206$$

$$X_M = 241.919$$

$$R = \frac{P_1}{I_1^2} \quad (49)$$

$$R_{LR} = \frac{46.119}{1.022^2}$$

$$R_{LR} = 44.155 \Omega$$

$$R_X = R - R_1 \quad (50)$$

$$R_2 = 44.155 - 12.340$$

$$R_2 = 31.815 \Omega$$

$$R_X + jX_X = \frac{(R_2 + jX_2') \times jX_M}{(R_2 + jX_2') \times jX_M} \quad (51)$$

$$R_X \approx \frac{R_2 \times jX_M^2}{(R_2 + jX_2') \times jX_M} \quad (52)$$

$$R_2 = R_X \times \left(\frac{X_2' + X_M}{X_M} \right)^2 \quad (53)$$

$$R_2 = 31.815 \times \left(\frac{30.308 + 241.919}{241.919} \right)^2$$

$$R_2 = 40.286 \Omega$$

In Summary, the per phase resistance and reactance in the motor is

$$X_M = 241.919 \Omega$$

$$X_1 = 20.206 \Omega$$

$$X_2 = 30.308 \Omega$$

$$R_1 = 12.340 \Omega$$

$$R_2 = 40.286 \Omega$$

6.2.2 Torque speed characteristics

Figure 16 is indicative of a squirrel cage motor that has a high rotor resistance. The starting torque and breakdown torque appear to be quite similar at around 7.5Nm.

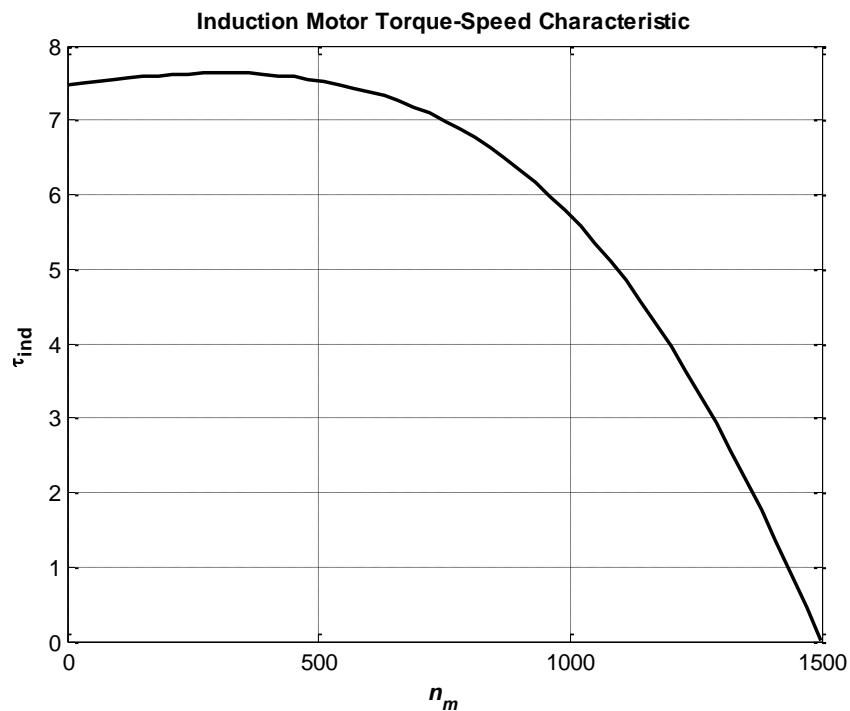

Figure 16 - Simulated torque-speed curve for the Leroy Somer induction motor

7 Conclusion

This project involved measuring the input currents and voltages of three phase induction motors under different operating conditions. The measurements were taken using the Voltech PM6000 Power Analyser which was configured to take readings on all three phases of the motor stator simultaneously. The data taken from this analysis was used to calculate circuit parameters so that the motors could be approximated by a per-phase equivalent circuit which further enables their performance characteristics to be investigated.

A system design was proposed which allows any similar motor to be connected so that its parameters can also be calculated, providing the system can provide sufficient power to the motor in question and that it operates within the specified ratings of the connected equipment. Special care should be taken when analysing motors with a wound rotor design because the impedance of the rotor can vary depending on its position relative to the stator. This is not the case with squirrel cage designs.

Most of the data that was gathered during this project was assumed to be reliable because the tests that were conducted could be replicated easily and with each trial there was minimal variation in the results. This was not the case when the locked rotor test conducted at a reduced frequency because of the significant amount of noise present in the power being supplied to the motor.

One of the drawbacks of this investigation is that it did not take into account the effects of resistance changes due to temperature increases and variations in the impedance due to the skin effect which means the calculated parameter values may not be a completely accurate representation of the motors under normal operating conditions. Regardless, the equivalent circuit is still only an approximation due to various assumptions that are made in the calculation procedure. The only way to properly verify that the calculations are correct would be through further investigation and by implementing the suggested recommendations in the following section of this report entitled *Future Work*.

8 Future Work

It is advised that a permanent setup is built with equipment placed on a rack or housed inside an insulated box. The VFD and the terminal boxes should be mounted inside the box so that the proposed system can be easily reconfigured for each of the tests. This setup should be built in accordance with clauses referred to in Section 5.2 and other relevant guidelines from AS/NZS 3000. In addition to this the following recommendations have been made.

8.1 Low Pass Filter

A passive RC filter is recommended for removing the harmonic content from the VFD's output. The main reason for having this is because, based on the observations in Section 6.1, the Power Analyser may have trouble taking accurate RMS measurements due to the large amount of distortion in the voltage waveform coming from the VFD. Noise can also have a negative effect on the performance of the induction motor by increasing core losses, increasing the skin effect, causing electromagnetic interference (EMI) and a deviation from the motor's torque-speed characteristics (Teja, Harmonic Effects on Induction Motors 2012).

The RC filter works by only allowing currents through that are below a given cut-off frequency f_c , which depends on the size of the capacitor and the resistor that are used in the filter circuit, where:

$$f_c = \frac{1}{2\pi RC} \quad (54)$$

At low frequencies, the capacitive reactance X_c becomes much larger than the resistance so most of the current does not flow through the capacitor. X_c is inversely proportional to f as per the following equation:

$$X_c = \frac{1}{2\pi fC} \quad (55)$$

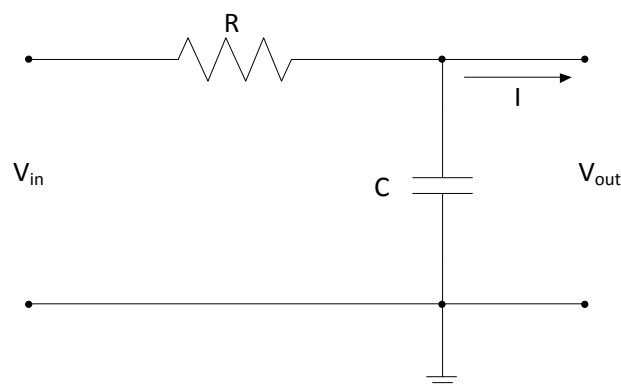

Figure 17 - Circuit diagram for a first order low pass RC filter

As the frequency is increased X_c becomes much smaller than R so most of the current flow is through the capacitor. Consequently the voltage drop across the output terminals becomes quite low (Storr 2014).

Depending on the values of R and X_c there will also be a certain voltage drop across the entire filter. In order to minimize this voltage drop components must be selected such that the output/input voltage ratio is close to one, where:

$$\frac{V_{out}}{V_{in}} = \frac{X_C}{\sqrt{R^2 + X_C^2}} \quad (56)$$

(Storr 2014)

For this project a filter that allows anything with a frequency equal to or below the maximum 12.5Hz needed for the locked rotor test would be desirable since the circuit would not be used for other tests where the motor is required to operate at the 50Hz line frequency. A cut-off frequency of 12.6Hz could be achieved with 200Ω resistors and 63μH capacitors connected on each phase as per Figure 18. Using these components there would be a voltage drop of around 28.9% when f_{supply} is equal to 12.6Hz, which is quite significant. Using these resistance values the VFD can supply 1.2A of phase current to the motor at 240V.

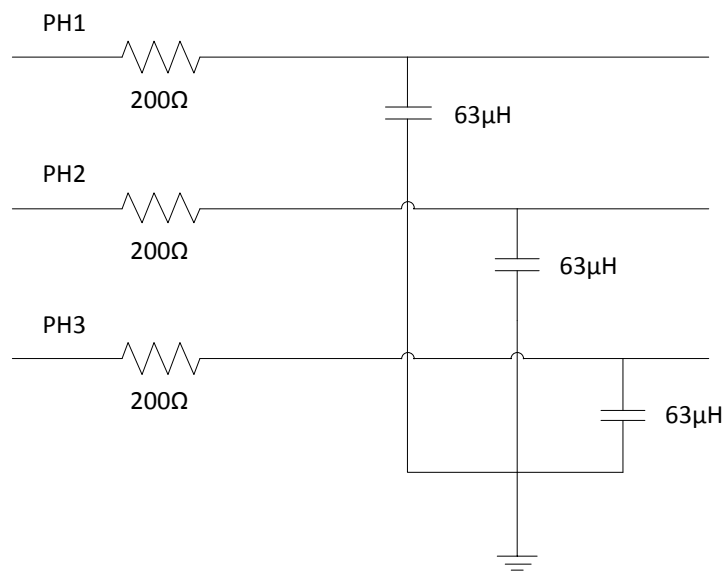

Figure 18 - Schematic for the proposed three phase RC filter

A higher order filter could be used instead if a first order RC circuit is not sufficient. One of the benefits of a higher order filter though is the narrower roll-off region which prevents frequencies slightly larger than f_c from passing through the circuit.

Figure 19 is a bode plot which demonstrates that the proposed filter could potentially allow a fair bit of noise through because the roll-off region is wide.

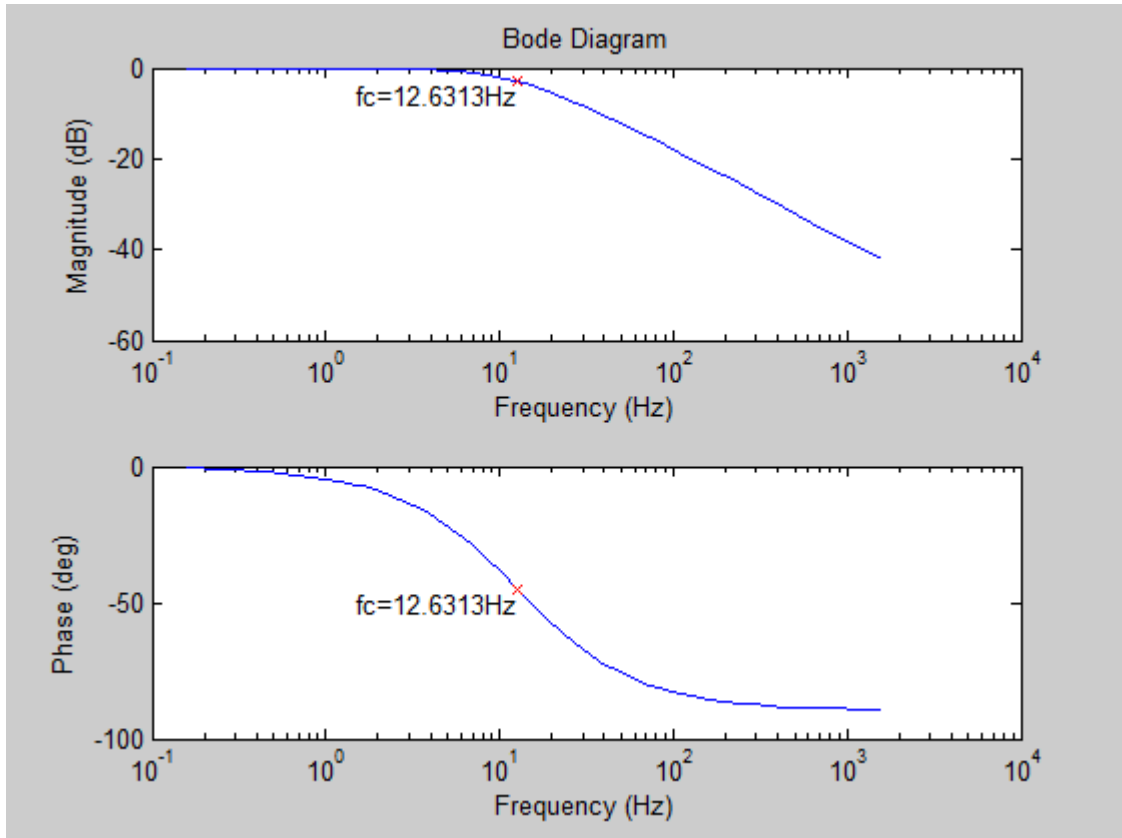

Figure 19 - Frequency response of the proposed first-order low pass filter

Increasing the cut-off frequency to 15Hz by using a 53 μ H capacitor instead would reduce the voltage drop to 23.2%. It should be noted that the cut-off of the filter does not need to match up exactly with the frequency of interest because at 12.5Hz the supply will likely produce harmonics of that frequency, and these higher harmonics are the waveforms we are interested in removing.

8.2 Calibration of the Power Analyser

It appears as though the PM6000 has not been calibrated since 2009. It is recommended that the instrument is recalibrated to ensure any future measurements taken are as accurate as possible.

8.3 Dynamometer

A dynamometer should be used to take torque measurements. This will allow students to compare the measured torque at various test points with a simulated torque speed curve based on their calculated motor parameters. If the data points match up well with the simulated curve this should be a good indication that the calculated parameters are correct. Dynamometers from the Lab-Volt equipment could be used for this however they are designed to operate together with less powerful machines and may not be suitable for the motors used in this project. Either they would have to be removed from the Lab-Volt system or the motors would have to be housed inside the system. The shaft of each motor would have to be modified so that a belt can be attached and the height of the dynamometers would need to be adjusted to match up with the shaft height of the motors, which is not ideal. Hence, a permanent solution should be found.

9 Appendices

The following appendices include Matlab scripts for generating the torque speed characteristic curve of the motors used in this project, the frequency response of an RC filter and also the PWM output of a VFD. Also included are the alternative calculation methods recommended by IEEE for accurately determining the equivalent circuit parameters of a polyphase induction motor.

9.1 Appendix 1 - Matlab Program for Torque Speed Characteristic Curve

The following code has been adapted from the Matlab script provided by Chapman in his textbook *Electric Machinery Fundamentals, 4th Edition*. (Chapman 2003).

```
% M-file: torque_speed_curve.m
% M-file create a plot of the torque-speed curve of the
% induction motor of Example 7-5.

% First, values needed in this program are initialised.
r1 = 12.340;           % Stator resistance
x1 = 20.206;           % Stator reactance
r2 = 40.286;           % Rotor resistance
x2 = 30.308;           % Rotor reactance
xm = 241.919;         % Magnetization branch reactance
v_phase = 415 / sqrt(3); % Phase voltage
n_sync = 1500;         % Synchronous speed (r/min)
w_sync = 157.08;      % Synchronous speed (rad/s)

% Thevenin voltages and impedances are calculated
v_th = v_phase * ( xm / sqrt(r1^2 + (x1 + xm)^2) );
z_th = ((j*xm) * (r1 + j*x1)) / (r1 + j*(x1 + xm));
r_th = real(z_th);
x_th = imag(z_th);

% Now the torque-speed characteristic for many slips between
% 0 and 1 are calculated. Note that the first slip value
% is set to 0.001 instead of exactly 0 to avoid divide-
% by-zero problems.
s = (0:1:50) / 50;    % Slip
s(1) = 0.001;
nm = (1 - s) * n_sync; % Mechanical speed

% The torque for the original rotor resistance is calculated
for ii = 1:51
    t_ind1(ii) = (3 * v_th^2 * r2 / s(ii)) / ...
        (w_sync * ((r_th + r2/s(ii))^2 + (x_th + x2)^2) );
end

% Plot the torque-speed curve
plot(nm,t_ind1,'Color','k','LineWidth',2.0);
hold on;
xlabel('\itn_{m}','Fontweight','Bold');
ylabel('\tau_{ind}','Fontweight','Bold');
title('Induction Motor Torque-Speed
Characteristic','Fontweight','Bold');
grid on;
hold off;
```

9.2 Appendix 2 - Matlab Program for Frequency Response of Proposed RC Filter

```
%First need to define filter parameters for the single phase
equivalent circuit
R = 200;
C = 6.3*10^-5;
RC = R*C;
fc = 1/(2*pi*RC);

%Creating the transfer function for the Bode plot
num = 1/RC;
den = [1 1/RC];
sys = tf(num, den);

%Generates the curves for Magnitude vs. Frequency and Phase Angle
vs.
%Frequency
bode(sys)

%Converts the x-axis units from rad/s to Hz
[Mag, Phase, W] = bode(sys);
Freq_Hz = W(:)/2/pi;
Mag_dB = 20*log10(Mag(:));

%Creates a label for the data point at the cutt-off frequency
labels = ['fc=', num2str(fc), 'Hz'];

%Adds labels to the first curve
subplot(2,1,1)
semilogx(Freq_Hz, Mag_dB)
title('Bode Diagram')
xlabel('Frequency (Hz)')
ylabel('Magnititude (dB)')
hold on
plot(fc,-3, 'rx');
text(fc,-3, labels, 'VerticalAlignment','top', ...
     'HorizontalAlignment','right')
hold off

%Adds labels to the second curve
subplot(2,1,2)
semilogx(Freq_Hz, Phase(:))
xlabel('Frequency (Hz)')
ylabel('Phase (deg)')
hold on
plot(fc,-45, 'rx');
text(fc,-45, labels, 'VerticalAlignment','top', ...
     'HorizontalAlignment','right')
hold off
```

9.3 Appendix 3 - Matlab Program for PWM Output of the Variable Frequency Drive

```
clc;
clear all;
t = 0:0.000001:1;
fc = 15.5;    %sawtooth frequency
fm = 1;      %reference sine wave frequency
a = 5;       %sawtooth amplitude
b = 4;       %reference sine wave amplitude
c = 1;       %PWM output amplitude

%Defines sine wave and sawtooth signals being compared inside the
%comparator
vc = a.*sawtooth(2*pi*fc*t,0.5);
vm = b.*sin(2*pi*fm*t);

%Creates the pulse width modulated output voltage by generating a
pulse
%when the absolute value of vm is equal or greater than the absolute
value
%of vc.
%The pulse is negative when vc is negative.
n = length(vc);
for i = 1:n
    if (vm(i)*vm(i)/(abs(vm(i)))>=vc(i)*vm(i)/(abs(vm(i))))
        pwm(i) = c*vm(i)/(abs(vm(i)));
    else
        pwm(i) = 0;
    end
end

%Creates subplot for comparator waveforms
subplot(2,1,1);
plot(t,vm,t,vc);
xlabel('Time');
ylabel('Amplitude');
title('Message Signal');
grid on;

%Creates subplot for PWM waveform
subplot(2,1,2);
plot(t,pwm);
xlabel('Time');
ylabel('Amplitude');
title('PWM Signal');
axis([0 1 -(2*c) 2*c]);
grid on;
```

9.4 Appendix 4 - Test Methods Recommended by IEEE

IEEE recommends a number of different methods for finding the parameters of an induction machine in *Standard 112: Test Procedure for Polyphase Induction Motors and Generators*. All of these methods are similar in nature to the method described in Section 3 and should yield the same, if not more accurate results. They are summarised below.

9.4.1 The No Load test

The no load test is performed by running the motor at the rated voltage and frequency with no connected load. It can be used to find individual losses in the machine which can be useful to know when looking at how well the machine converts electricity into mechanical energy. To do this IEEE recommends running the test at 125% of the rated voltage down to the point where a further reduction in voltage increases the current.

For determining windage and frictional losses, the stator I^2R losses are subtracted from the total no load loss (the measured input power) at each test point and the resulting values are graphed against the voltage, with the curve extending down to zero voltage. The intercept with the zero voltage axis is the winding and friction loss.

The core loss is obtained by subtracting the friction and windage loss and the stator losses from the input power. A plot can then be constructed for finding the core loss at any desired voltage.

9.4.2 Method 1

Summary:

The first method involves the no load test described above and a three phase locked rotor test performed at no more than 25% of the rated frequency that can be supplied to the motor. During the locked rotor test, several readings of the voltage, the current and the input power are taken on all phases, at different levels of voltage. The voltage on each phase should be balanced. The stator winding resistance or temperature is also recorded quickly so that the windings do not overheat. The temperature can be equalized by taking the higher readings first and then the lower readings (IEEE Power Engineering Society 2004).

It should be noted that a wound-rotor's impedance will change with the position of the rotor relative to the stator. As a result, it is necessary to know the position of the rotor that results in an average impedance when performing this test. This issue does not apply to squirrel cage motors as their impedance is always the same regardless of the position of the rotor (IEEE Power Engineering Society 2004).

After completing the locked rotor test IV and PV curves are plotted and values of voltage and input power are derived from the curves in order to find the resistance and reactance of the machine at the desired level of current. These values are calculated using the procedure described below. The calculations assume a relationship between X_1 and X_2 based on the rotor design. For example:

$$\frac{X_1}{X_2} = 1.0 \text{ for Type A, Type D motors and wound rotor induction motors}$$

$$\frac{X_1}{X_2} = 0.67 \text{ for Type B motors}$$

$$\frac{X_1}{X_2} = 0.43 \text{ for Type C motors}$$

(IEEE Power Engineering Society 2004)

These values can be derived from Table 1.

Calculation Procedure:

Using the test data from the locked rotor test described above, the reactive power Q_L is determined as a function of the phase voltage $V_{1,L}$, the phase current $I_{1,L}$ and the input power P_L is given by:

$$Q_L = \sqrt{(mV_{1,L}I_{1,L})^2 - P_L^2} \quad (57)$$

Where m is the number of phases.

Then using results gathered from the no load test, the reactive power Q_0 is calculated under no load conditions as a function of the phase voltage $V_{1,0}$, phase current $I_{1,0}$ and the input power P_0 using the following equation:

$$Q_0 = \sqrt{(mV_{1,0}I_{1,0})^2 - P_0^2} \quad (58)$$

The magnetizing reactance X_M and the stator reactance X_1 can then be calculated using an iterative procedure where:

$$X_M = \frac{mV_0^2}{Q_0 - mI_{1,0}^2 X_1} \times \left(\frac{1}{(1 + X_1/X_M)^2} \right) \quad (59)$$

$$X_{1,L} = \frac{Q_L}{mI_{1,L}^2 (1 + X_1/X_2 + X_1/X_M)} \times (X_1/X_2 + X_1/X_M) \quad (60)$$

Where $X_{1,L}$ is the stator reactance at the locked rotor test frequency.

The stator reactance at the rated frequency is given by:

$$X_1 = \frac{f}{f_L} \times X_{1,L} \quad (61)$$

Where f is equal to 50Hz and f_L is the reduced locked rotor test frequency.

Firstly, X_M is estimated by assuming values for X_1/X_M and X_1 .

$X_{1,L}$ is estimated using the same value of X_1/X_M . The value for X_1/X_2 is selected based on the motor design as explained in the previous section.

Using the value obtained for $X_{1,L}$ the value for X_1 at the rated frequency is calculated.

Values obtained for X_1 and X_M are then used to calculate new values for X_1 and X_M . The process is repeated until X_M and X_1 are within 0.1% of their previous iterations. Then, using the selected X_1/X_2 ratio X_2 is calculated at the rated frequency. If convergence is not reached after 10 iterations, it is likely that the initial guesses for the parameters are not good approximations of the final values and new values should be chosen.

The final stage of this method involves determining the core loss resistance R_C and the resistance of the rotor R_2 , referred to the stator side. R_C is defined in the standard as the inverse of the core loss conductance G_C , which is a function of the total core loss P_h (described in Section 5.5.5 of the standard), the no load phase voltage $V_{1,0}$ and the X_1/X_M ratio. It can be calculated based on the following equation:

$$G_C = \frac{P_h}{mV_{1,0}^2} \times \left(1 + \frac{X_1}{X_M}\right)^2 \quad (62)$$

Hence:

$$R_C = \frac{1}{G_C} \quad (63)$$

To find R_2 , $R_{2,L}$ is first calculated at the locked rotor test frequency:

$$R_{2,L} = \left(\frac{P_L}{mI_{1,L}^2} - R_{1,L}\right) \times \left(1 + \frac{X_2}{X_M}\right)^2 - \left(\frac{X_2}{X_1}\right)^2 \times (X_{1,L}^2 G_C) \quad (64)$$

$R_{1,L}$ is equal to half of the line to line stator resistance at the test temperature. $R_{1,L}$ and $R_{2,L}$ are then corrected to the required temperature as per Section 5.2.1 of the standard.

(IEEE Power Engineering Society 2004)

9.4.3 Method 2

Summary:

The second method involves performing a no load test and then a locked rotor test at multiple frequencies. The first one is performed at the rated frequency, the second at 50% rated frequency and the third one at 25% of the rated frequency. All locked rotor tests are conducted at the rated current (IEEE Power Engineering Society 2004).

Calculation Procedure:

The same calculation procedure used in Method 1 is used to determine the total leakage reactance $X_{1,L} + X_{2,L}$ and the rotor resistance $R_{2,L}$, at each test point. Curves of rotor resistance vs. frequency and total leakage reactance vs. frequency are then plotted in order to determine these resistance and reactance values at the required reduced frequency. These values are then used to find the other parameters in the motor's equivalent circuit, as per Method 1 (IEEE Power Engineering Society 2004).

9.4.4 Method 3

Summary

The third method involves performing an impedance test at a slip speed approximating the desired reduced rotor frequency. The motor is allowed to run unloaded or with a reduced load and the voltage is reduced to give the full load slip point (IEEE Power Engineering Society 2004).

Calculation Procedure:

From the reduced voltage slip test the rotor resistance R_2 and the leakage reactance X_2 are obtained at a reduced frequency. A no load saturation test described in Section 5.5 of the IEEE Standard is also performed. Using the measurements from this test, the reactance X on each phase

is determined at each test point and a plot of reactance vs. phase voltage is created (see Figure 20). The highest point on the curve gives the total no load reactance for each phase, $X_1 + X_M$, which is used in the calculations for the reduced voltage slip test (IEEE Power Engineering Society 2004).

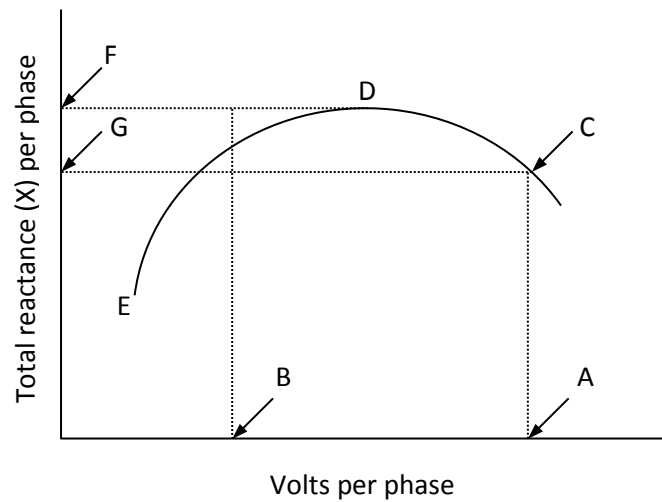

Figure 20 - The total reactance from the no load test (see text for description of labels)

In relation to Figure 20:

A is the rated voltage

B is the voltage measured during the reduced voltage slip test

CDE is the total no load reactance determined from the no load test points

F is the reactance which corresponds to D, the highest point on the curve (CDE). This value is used in calculations for the reduced voltage slip test as the total reactance $X_1 + X_M$.

G is the total reactance $X_1 + X_M$ which is used for calculating X_M in the per phase equivalent circuit after X_1 , X_2 and R_2 are found from the reduced voltage slip test.

(IEEE Power Engineering Society 2004)

Using the data obtained from the reduced voltage slip test, the total impedance per phase Z can be determined, and then power factor can be calculated. Using the power factor the phase angle of the input current can be calculated where:

$$\theta_1 = -\arccos(PF) \quad (65)$$

The total apparent reactance per phase X and the total apparent resistance per phase R can then be calculated since both are a function of the impedance Z and the input current phase angle.

$$X = Z \times \sin(-\theta_1) \quad (66)$$

$$R = Z \times \cos(-\theta_1) \quad (67)$$

The value for X calculated is used as an initial estimate for the sum of the rotor and stator reactances $X_1 + X_2$. A value for $\frac{X_1}{X_2}$ is determined based on the motor design. Then, the stator reactance can then be found as follows:

$$X_1 = X \left(\frac{X_1/X_2}{1+X_1/X_2} \right) \quad (68)$$

Using the value for $X_1 + X_M$ obtained from Figure 20, the magnetizing reactance X_M is approximated by:

$$X_M = (X_1 + X_M) - X_1 \quad (69)$$

Using the reduced voltage slip test data, the induced rotor voltage V_2 and current I_2 referred to the stator are calculated and X_2 is found. Then:

$$X = X_1 + X_2 \quad (70)$$

Using the new value for X and the X_1/X_2 ratio that was previously determined the calculation process is repeated until X_1 and X_2 are within 0.1% of their previous iterations. Then:

$$Z_2 = V_2/I_2 \quad (71)$$

$$R_2 = s\sqrt{Z_2^2 - X_2^2} \quad (72)$$

Using the value for total no load reactance ($X_1 + X_M$) obtained from the no load test point C , the magnetizing reactance X_M is then determined by subtracting X_1 from $X_1 + X_M$. The rotor and stator resistances are corrected to the normal operating temperature (IEEE Power Engineering Society 2004).

9.4.5 Method 4

If no other method is practical a full load slip test can be used to determine R_2 followed by a no load and locked rotor test to determine the remaining impedances as per Method 1 (IEEE Power Engineering Society 2004).

10 Bibliography

- Amick, Christopher, Paul Avery, and Yaskawa Amer. *Machine Design*. 1 December 2010.
<http://machinedesign.com/motorsdrives/abcs-and-1-2-3s-variable-frequency-drives>
(accessed November 2, 2014).
- Bhatia, A. *Understanding Motor Nameplate Information: NEMA v/s IEC Standards*. Fairfax, Virginia, n.d.
- British Standards Institution. *Degrees of Protection Provided by Enclosures for Electrical Equipment Against Mechanical Impacts (IK Code)*. 15 October 1995.
- Chan, Tze Fun, and Keli Shi. "Appendix H Experiment 1: Measuring the Electrical Parameters of Motor 3." In *Applied Intelligent Control of Induction Motor Drives*, by Tze Fun Chan and Keli Shi, 397-401. John Wiley & Sons Pte Ltd., 2011.
- Chapman, Stephen. *Electric Machinery Fundamentals*. New York: McGraw-Hill, 2003.
- Daware, Kiran. *Three Phase Induction Motors*. n.d. <http://www.electriceasy.com/2014/02/three-phase-induction-motor.html> (accessed October 17, 2014).
- Energy Management Corporation. *VFDs.com*. 20 March 2014. <http://www.vfds.com> (accessed October 11, 2014).
- Gonen, Turan. *Electrical Machines with MATLAB, Second Edition*. London: CRC Press, 2011.
- IEEE Power Engineering Society. *IEEE Standard Test Procedure for Polyphase Induction Motors and Generators*. New York, 4 November 2004.
- Indian Institute of Technology. *Lesson 30 - Construction and Operation of Induction Motors*. Kharagpur, 25 August 2006.
- Kothari, D.P, and I.J. Nagrath. *Modern Power System Analysis*. New Dehli: McGraw Hill, 2003.
- Leroy Somer. "Nameplate Data for 3 Phase Induction Motor." n.d.
- Missouri University of Science and Technology. "Induction Motor Parameter Measurement." *Electrical and Computer Engineering*. n.d.
http://ece.mst.edu/media/academic/ece/documents/classexp/ee208labs/09_-_Induction_Motor_Parameter_Measurement.pdf (accessed December 22, 2014).
- Natural Resources Canada. *Principles of Operation - AC VFD Drives*. 6 June 2014.
<http://www.nrcan.gc.ca/energy/products/reference/15433> (accessed October 3, 2014).
- Novak, Peter. *EC&M Electrical Construction and Maintenance*. 1 May 2009.
<http://ecmweb.com/power-quality/basics-variable-frequency-drives> (accessed October 25, 2014).
- Polka, Dave. *Variable Speed Drives and Controls*. 2001.
http://www.joliettech.com/what_is_a_variable_frequency_drive-how_vfd_works.htm
(accessed October 16, 2014).

- Pontiac Electric Motors and Drives. *Metric Dimensions Charts*. n.d. <http://www.electric-motor-works.com/store/metric-dimensions-charts.php> (accessed September 19, 2014).
- SEW Eurodrive. *Movitrac 07 System Manual*. Bruchsal, Germany, February 2003.
- Standards Australia. *AS/NZS 3000:2007 Wiring Rules*. Sydney, 2007.
- Storr, Wayne. *Passive Low Pass Filter*. 2014. http://www.electronics-tutorials.ws/filter/filter_2.html (accessed November 24, 2014).
- Teja, Dharma. *Harmonic Effects on Induction Motors*. 12 January 2012. <http://electricalquestionsguide.blogspot.com.au/2012/01/harmonics-effect-induction-motor-impact.html> (accessed October 26, 2014).
- . *Squirrel Cage Induction Motors: Advantages, Disadvantages and Applications*. 15 November 2011. <http://electricalquestionsguide.blogspot.com.au/2011/11/squirrel-cage-induction-motor.html> (accessed November 13, 2014).
- The Engineering Toolbox. *IEC Duty Cycles*. 2014. http://www.engineeringtoolbox.com/iec-duty-cycles-d_739.html (accessed October 20, 2014).
- The Institution of Electrical Engineers. *Power System Protection 3: Application*. London: The Institution of Electrical Engineers, 1997.
- Toshiba International Corporation. "Nameplate Data for 3 Phase Induction Motor." n.d.
- Voltech Instruments Inc. *Voltech PM6000 User Manual Issue 19*. Fort Myers, FL., 21 January 2009.