



Installation and User Guide

Search **You Tube**

"sona CO installation"

WCOB-SN-1

Carbon Monoxide Alarm with Wi-Safe 2[®]

PLEASE READ THIS GUIDE IN FULL BEFORE USING YOUR WCOB-SN- ALARM!

This user guide is also available in large text and other formats. Please call **0800 171 2009** for further information.

Battery powered Alarm Control Unit with Test, Silence, Locate function. Non-replaceable 3V DC battery.

W2 module contained within product independently tested to RF standard ETSI EN 300 220-2 V2.3.2 (2010-02) by TRaC Global Ltd.

Email: **technicalsupport@sonasafety.com** / Web: **www.sonasafety.com**

Technical Support Line: **0800 171 2009**



EN 50291-1:2010
EN 50291-2:2010
KM 551504



A Sprue Brand

Sprue Safety Products Ltd. Vanguard Centre, Coventry CV4 7EZ UK

INSTALLATION GUIDE

Features	4
Positioning	4
Installation.	7
Wireless Interlink	9

USER GUIDE

Alarm Test	11
Sleep Easy™.	12
What to do in the Event of an Alarm.	13
Carbon Monoxide: How it Can Affect You and Your Family	14
Product Indicators.	16
Maintenance.	17
Disposal	18
Warranty.	18

INSTALLATION GUIDE

FEATURES

- Wi-Safe 2® technology, enabling wireless interlinking between other Wi-Safe 2 alarms.
- An advanced electrochemical sensor designed to accurately measure low levels of carbon monoxide (CO) providing an early warning of toxic CO levels in your home.
- Detects carbon monoxide continuously.
- Resistant to false alarms caused by normal household contaminants.
- Sounds a loud 85dB alarm (at 1 m) to alert you in case of an emergency.
- Test /  button.
- Regular self-check to ensure alarm is operating correctly.
- Certified to the European Carbon Monoxide Alarm Standard EN 50291-1: 2010 and EN 50291-2: 2010.
- Temperature Range: -10°C (14°F) to 40°C (104°F) / Operating Humidity Range: 30 - 90% RH
- 5 year warranty.

POSITIONING



This CO alarm is suitable for use in domestic premises as well as caravans and motor caravans.

The following advice, from BS EN 50292-2013 is applicable to all intended applications. There are special instructions at the end of this section relating to positioning in caravan holiday homes.

WARNING: This alarm will only indicate the presence of carbon monoxide gas at the sensor. Carbon monoxide gas may be present in other areas.

IN WHICH ROOM SHOULD THE ALARM BE INSTALLED?

Ideally, an alarm should be installed in every room containing a fuel-burning appliance. Additional alarms may be installed to provide adequate warning for occupants in other rooms, by placing alarms in rooms in which they spend considerable time whilst awake.

However, if there is a fuel-burning appliance in more than one room and the number of alarms is limited, the following points should be considered when deciding where best to put the alarm:

- Locate the alarm in a room containing a flueless or open-flued appliance.
- Locate the alarm in a room where the occupant(s) spend most time.
- If the domestic premises is a bedsit (a single room serving as both sitting and bedroom) then the alarm should be put as far from the cooking appliances as possible and near to where the person sleeps.
- If the appliance is in a room not normally used (for example a boiler room), the alarm should be put just outside the room so that it may be heard more easily.

WHERE IN THE ROOM SHOULD I PLACE THE ALARM?

For alarms located in the same room as a fuel-burning appliance (for both wall and ceiling mounted alarms) the following applies:

- The alarm should be at a horizontal distance of between 1 m and 3m from the potential source.
- If there is a partition in a room, the alarm should be located on the same side of the partition as the potential source.
- Carbon monoxide alarms in rooms with sloped ceilings should be located at the high side of the room.

In addition to the above the following must be observed if the alarm is located on a wall:

- It should be located close to the ceiling.
- It should be located at a height greater than the height of any door or window.
- It should be at least 150 mm from the ceiling.

If the alarm is located on the ceiling:

- It should be at least 300 mm from any wall and any ceiling obstruction e.g. light fittings.

Alarms located in sleeping rooms and in rooms remote from a fuel-burning appliance should be located relatively close to the breathing zone of the occupants.

CARAVANS

Caravans may have additional risks of carbon monoxide admission through air vents, due to the nearby presence of other vehicles, engines, generators or barbecues, however this does not change the basic guidance on the location of the alarm.

Caravans should be fitted with an alarm in the same room as any combustion appliance(s), located in accordance with previous advice in this section. If the caravan has a single living space which incorporates the sleeping accommodation, it can be considered to be equivalent to a bedsit, and a single alarm is sufficient. However, any sleeping accommodation which is in a separate room from the combustion appliance(s) should also contain an alarm, located in accordance with previous advice in this section. It is not always possible to find an optimum location for an alarm, for example, a small caravan may not have suitable vertical surfaces available. Nevertheless, when fitting an alarm in such situations, the two most important considerations when selecting an appropriate location are:

- Not mounting the alarm directly above a source of heat or steam.
- Mounting the alarm at a distance of 1-3m from the nearest edge of the potential source of CO.

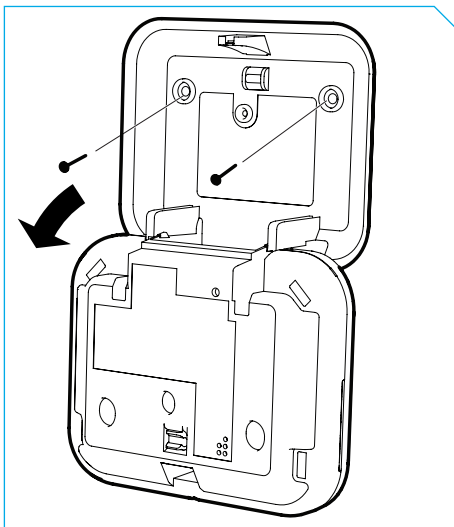

INSTALLATION

✓ DO

- Ensure this alarm is installed by a competent person who feels able to install it according to the instructions.

✗ DO NOT:

- Tamper with the alarm, for risk of electric shock or malfunction!

There are two alternative ways to mount your CO alarm onto a wall:

1. Using the 2 x screws

Flip down the CO alarm, away from the bracket. Please ensure that you use the screws provided, as they were chosen specifically for use with this product. Drill holes into the wall. Insert the plastic wall plugs. Using a screwdriver push out the plastic knockouts in the bracket (see illustration). Using the holes as a guide, drill the screws through to secure the bracket in place.

2. Using the single point fixing option

Flip down the CO alarm, away from the bracket. Place the nail (provided) through the central hole in the bracket. Carefully hammer the nail into the wall until the CO alarm is secured into place.

FREE-STANDING

Alternatively you can place your CO alarm on a shelf. The base of the alarm has been designed to allow it to stand freely.

IMPORTANT: When placing on a shelf, please follow the recommendations for positioning (See 'Positioning').

ACTIVATING YOUR CO ALARM

Your CO alarm has an integrated power pack. To activate the power pack you need to remove the disabling clip by pulling it out of the alarm. Retain the disabling tab for future use by taping into this manual.

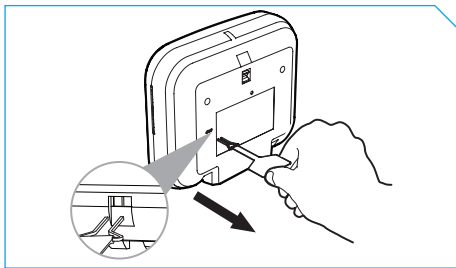
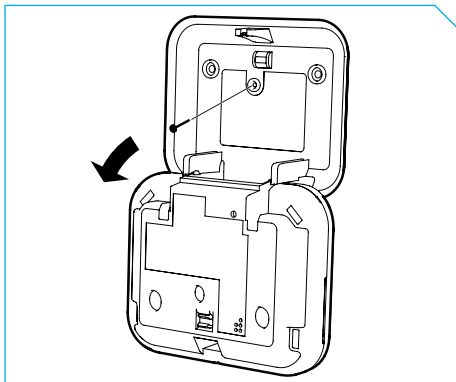

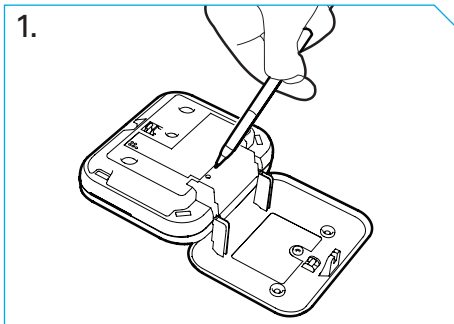
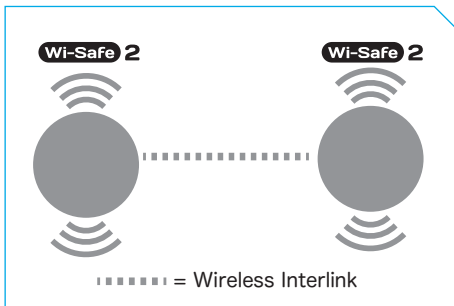

When the alarm is activated the Power LED will begin to flash green once every minute to indicate that the alarm is fully operational. Test the sounder, power pack and circuitry by pressing and holding the centre of the Test /  button briefly to confirm that the alarm is operating correctly. The alarm will sound as soon as the button is pressed, and the Alarm LED will illuminate red indicating that the alarm is working and the power pack is providing power to the unit.

WIRELESS INTERLINK

The SONA WCOB-SN-1 is designed to be wirelessly interlinked with up to 50 products (CO, Smoke and Heat alarms) within the Wi-Safe 2 product range (both battery operated and mains powered). The WCOB-SN-1 is not designed to communicate with wireless alarms from other ranges or manufacturers. WCOB-SN-1 alarms need to be 'learned-in' or interlinked in order to communicate with each other. If one alarm activates, all other interlinked alarms will also sound.

Wi-Safe 2 enables wireless communication with any other product with Wi-Safe 2 technology inside. When one alarm detects CO the wireless

unit inside sends a radio frequency signal to all the connected alarms, ensuring almost instantaneous reaction across the entire network.

How to 'learn-in' two wireless alarms into a network:

Install Alarm 1 as described earlier.

1. Using a ballpoint pen, briefly push and release the 'learn button' on the back of Alarm 2. The red LED next to the learn button will flash briefly then light up for approximately five seconds.
2. During these five seconds you need to briefly press the test button on Alarm 1 to wirelessly interlink the two alarms. Alarm 1 will give an audible sound consisting of two cycles of three loud beeps.
3. The red LED on Alarm 2 will flash to indicate that it has been 'learned-in' successfully. If the test button is not pressed quickly enough, the 'learn-in' process will fail. If this happens, repeat the process. To complete the installation fit Alarm 2 into position. When 'learning-in' additional alarms, any alarm already in the network, can be used as 'Alarm 1'. This means that you can 'learn-in' the additional alarm to any alarm already in the network. It will then become part of the whole network. You do not have to 'learn-in' to every alarm in the network.

2.

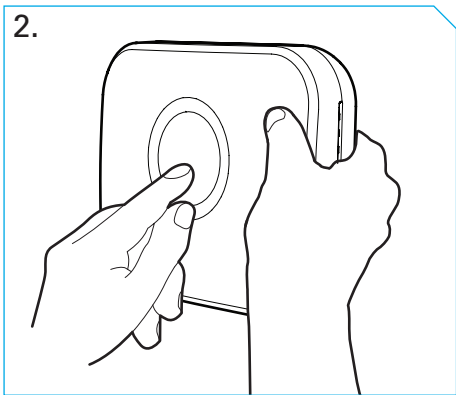

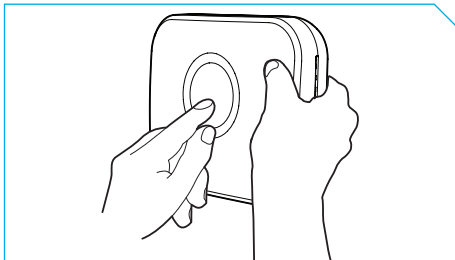

ALARM TEST

Test the sounder, power pack and circuitry by pressing and releasing the Test /  button to confirm that the alarm is operating properly. The sounder should sound as soon as the Test button is pressed, and the Alarm LED will illuminate red indicating that the sounder is working and the power pack is providing power to the unit. This test should be performed on a weekly basis.



TESTING THE SENSOR

NOTE: We suggest the use of Easy Gas as this produces a readable localised amount of carbon monoxide. Please contact Technical Support for availability of Easy Gas.

CAUTION: Sensor testing should only be performed by a responsible adult and should only be performed annually. Excessive testing will cause the life of the power pack to be shortened.

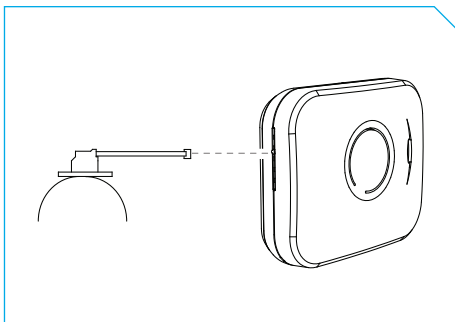
- If the alarm is wall or ceiling mounted unscrew it.



- Fit the straw (supplied with Easy Gas) into the nozzle. Fit the adaptor onto the straw and attach the adaptor into the side of the alarm.
- Cover the sounder vents with one hand. Press and hold the Test /  button down with your thumb/finger until the Fault LED illuminates amber and the sounder sounds for a second time (this should happen after around five seconds). Release the Test /  button. Upon releasing the Test /  button the Fault LED will flash amber once every second. This indicates that the sampling rate of the alarm has increased and can be tested using a known source of CO.
- Depress the nozzle on the Easy Gas canister for 1-2 seconds. Within a further 10-20 seconds the amber 'fault' light will remain on and the alarm will sound 4 chirps. This proves the sensor is detecting CO.
- If the alarm fails to respond, repeat the test above, depressing the nozzle for 5 seconds. If the alarm still fails to respond, contact our Technical Support team on 0800 171 2009.
- After activation, the alarm will revert to its normal operating mode automatically. Remove the straw and adaptor from the alarm.
- The Fault LED will no longer flash amber and the alarm will go back to normal operating mode ie. the Power LED will flash green once every minute.

NOTE: If the localised carbon monoxide level within the sensor does not reach 50 ppm during the test, the sensor test will stop automatically after three minutes.

SLEEP EASY™

Low battery warnings often start at night or when it may be inconvenient to replace your alarm. You can silence the audible 'low battery' chirp for a period of eight hours by pressing the test button. After this period the audible chirp will start again. This process can be repeated for a maximum of 10 times. Your alarm will still detect CO during this time, however you must replace your alarm within 30 days, as it may have insufficient power to warn you of a real CO leak after this time.

WHAT TO DO IN THE EVENT OF AN ALARM

WARNING: A loud alarm is a warning that potentially lethal levels of carbon monoxide are present. Never ignore this alarm, further exposure can be fatal. Immediately check residents for symptoms of carbon monoxide poisoning, and contact the proper authorities to resolve all CO problems.

NEVER IGNORE ANY ALARM.

Please carefully review this guide to ensure that you know what actions to take in the event of an alarm.

WHAT TO DO DURING AN ALARM:

- Keep calm and open the doors and windows to ventilate the property.
- Stop using all fuel-burning appliances and ensure, if possible, that they are turned off.
- Evacuate the property leaving the doors and windows open.
- Ring your gas or other fuel supplier on their emergency number; keep the number in a prominent place.
- Do not re-enter the property until the alarm has stopped. When exposed to fresh air it can take up to 10 minutes for the sensor to clear and the alarm to stop depending on the level of carbon monoxide detected.
- Get medical help immediately for anyone suffering the effects of carbon monoxide poisoning (headache, nausea), and advise that carbon monoxide poisoning is suspected.
- Do not use the appliances again until they have been checked by an expert. In the case of gas appliances the engineer must be registered on the Gas Safe register.

WARNING: Alarms conforming to this standard may not protect people who are at special risk from carbon monoxide exposure by reason of age, pregnancy or medical condition. If in doubt, consult your doctor.

CARBON MONOXIDE: HOW IT CAN AFFECT YOU AND YOUR FAMILY

Carbon monoxide is a dangerous, poisonous gas that kills or injures hundreds of people each year. It is often referred to as the silent killer because it has no odour or taste and cannot be seen. Like oxygen, CO enters the body through the lungs during the normal breathing process. It competes with oxygen by replacing it in the red blood cells, thereby reducing the flow of oxygen to the heart, brain and other vital organs. In high concentrations, CO can kill in minutes.

Many cases of reported carbon monoxide poisoning indicate that while victims are aware they are not feeling well, they become disorientated and unable to save themselves by either exiting the building or calling for assistance. Exposure during sleep is particularly dangerous because the victim may not wake up.

SYMPTOMS OF CARBON MONOXIDE (CO) POISONING:

- Mild Exposure: Slight headache, nausea, vomiting, fatigue (often described as 'flu-like' symptoms).
- Medium Exposure: Severe throbbing headache, drowsiness, confusion, fast heart rate.
- Extreme Exposure: Unconsciousness, convulsions, cardiorespiratory failure, death.

Your CO alarm monitors the level of CO as parts per million (ppm) in the atmosphere surrounding the alarm:

- 35 ppm - The maximum allowable concentration for continuous exposure for healthy adults in any eight hour period, as recommended by the Occupational Safety and Health Administration (OSHA).
- 200 ppm - Slight headache, fatigue, dizziness, nausea after 2 - 3 hours.
- 400 ppm - Frontal headaches within 1 - 2 hours, life threatening after three hours.

- 800 ppm - Dizziness, nausea and convulsions within 45 minutes. Unconsciousness within two hours. Death within 2 - 3 hours.

The Alarm will sound:

- Between 60 and 90 minutes when exposed to 50ppm of CO
- Between 10 and 40 minutes when exposed to 100ppm of CO
- Within 3 minutes when exposed to 300ppm or more of CO.

Should you suspect CO may be affecting you or your family, open the doors and windows of your property to ventilate, turn off your appliances and evacuate the premises. At this time the authorities should be contacted to locate the source of the carbon monoxide before re-entering the building. Medical attention should be sought for anyone suffering the effects of CO poisoning.

COMMON SOURCES OF CO:

- Oil and gas boilers
- Portable generators
- Oil or solid fuel cookers
- Gas or paraffin heaters
- Barbecues
- Clogged chimneys
- Wood or gas fireplaces
- Cigarette smoke
- Gas appliances
- Any fossil fuel-burning wireless

WARNING: This carbon monoxide alarm is not a combustible gas detector, nor a smoke detector. Please install the proper alarms to detect combustible gases, or smoke.

This CO alarm should not be seen as a substitute for the proper installation, use and maintenance of fuel-burning appliances (including appropriate ventilation and exhaust systems), nor the sweeping of chimneys.

WARNING: Variables relating to your fuel-burning appliances can change at any point eg. the flue

or chimney could suddenly become blocked or damaged, appliances may stop running correctly or circumstances in neighbouring properties may change resulting in the presence of carbon monoxide. For this and other reasons do not use this carbon monoxide alarm on an intermittent basis, or as a portable alarm for trying to trace one source of the spillage of combustion products from fuelburning appliances or from chimneys.

PRODUCT INDICATORS

Mode	Green LED	Red LED	Amber LED	Chirp
Normal Operation	Flashes once per minute	-	-	-
Alarm Mode	-	Flashes once every five seconds	-	Four audible 'chirps' repeated
Low battery/End of sensor life	-	-	Flashes once per minute	Chirps once per minute at the same time as the amber LED flashes
Sensor fault	-	-	Double flashes	Chirps at a different time to the amber LED flashes

IMPORTANT: Under normal operating conditions, the power pack will provide power to the product for longer than the life of the sensor, which is ten years. It is therefore recommended to replace the alarm 10 years after installation.

Problem

Solution

<p>The Alarm LED (red) is flashing</p>	<p>If the red LED is flashing every second and the alarm is sounding, a carbon monoxide leak has been detected. Keep calm and open the doors and windows to ventilate the property. Stop using all fuel burning appliances and ensure, if possible, that they are turned off. Evacuate the property leaving the doors and windows open. Contact your gas or other fuel supplier on their emergency number.</p>
<p>The Fault LED (amber) is illuminated and the alarm is making a "chirping" sound.</p>	<p>If the amber LED is flashing once per minute and at around the same time as the chirp, this indicates a low battery or end of life condition and the alarm should be replaced as soon as possible and certainly within 30 days.</p> <p>If this fault occurs at night, when it may be inconvenient to replace your alarm, please refer to the 'Sleep Easy' feature.</p> <p>If the amber LED is flashing once per minute or double flashing but at a different time to the chirp, this indicates a fault and the alarm should be replaced immediately.</p>

MAINTENANCE

Your CO alarm will alert you to potentially hazardous CO concentrations in your home when maintained properly. Your CO alarm should be cleaned every 3 months. Keep the alarm free from dust by gently vacuuming the case with a soft brush attachment.

To prevent the possibility of contaminating the sensor in your alarm and affecting its reliability:

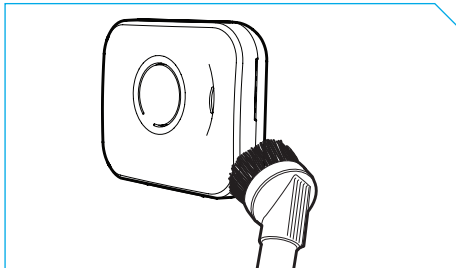

- Never use cleaning solutions on your alarm. Simply wipe with a slightly damp cloth.
- Do not paint the alarm.
- Do not spray aerosols on or near the alarm.
- Do not use any solvent based products near the alarm.
- Do not attempt to repair your CO alarm.
- Do not remove any screws or open the main casing of your CO alarm. Any attempt to do so may cause malfunction and will invalidate the warranty.

DISPOSAL

Waste electrical products should not be disposed of with your other household waste. The alarm is ideally suited for disposal within the waste electronic and electrical equipment (WEEE) recycling scheme. Please recycle where facilities exist. Check with your local authority, retailer or contact our Technical Support team for recycling/disposal advice, as regional variations apply.

WARNING: Do not burn or dispose of in fire.

WARNING: If your alarm is dropped or damaged, as a precaution, it should be removed from the building and you should contact Technical Support on **0800 171 2009** or **technicalsupport@sonasafety.com**.

WARRANTY

Sprue Safety Products Ltd warrants to the original purchaser that its enclosed CO alarm be free from defects in materials and workmanship under normal residential use and service for a period of five years from the date of purchase. Provided it is returned with postage prepaid and proof of purchase date, Sprue Safety Products Ltd hereby warrants that during the five year period commencing from the date of purchase Sprue Safety Products Ltd, at its discretion, agrees to replace the unit free of charge.

The warranty on any replacement WCOB-SN-1 alarm, will last for the remainder of the period of the original warranty in respect of the alarm originally purchased – that is from the date of original purchase and not from the date of receipt of the replacement product. Sprue Safety Products Ltd reserves the right to offer an alternative product similar to that being replaced if the original model is no longer available or in stock. This warranty applies to the original retail purchaser from the date of original retail purchase and is not transferable. Proof of purchase is required. This warranty does not cover damage resulting from accident, misuse, disassembly, abuse or lack of reasonable care of the product, or applications not in accordance with the user guide. It does not cover events and conditions outside of Sprue Safety Products Ltd's control, such as Acts of God (fire,

severe weather etc.). It does not apply to retail stores, service centres or any distributors or agents. Sprue Safety Products Ltd will not recognise any changes to this warranty by third parties.

Sprue Safety Products Ltd shall not be liable for any incidental or consequential damages caused by the breach of any expressed or implied warranty. Except to the extent prohibited by applicable law, any implied warranty of merchantability or fitness for a particular purpose is limited in duration for five years. This warranty does not affect your statutory rights. Except for death or personal injury, Sprue Safety Products Ltd shall not be liable for any loss of use, damage, cost or expense relating to this product or for any indirect or consequential loss, damages or costs incurred by you or any other user of this product.



Carbon Monoxide Alarm
Wireless: **WCOB-SN-1**

Heat Alarm
Wireless: **WHM-SN-1**
Non-Wireless: **HM-SN-1**

Smoke Alarm
Wireless: **WSM-SN-1**
Non-Wireless: **SM-SN-1**

Alarm Control Unit
Wireless: **WTSL-SN-1**

Wi-Safe® 2

Available on all wireless products