

Breakout board V5 user manual

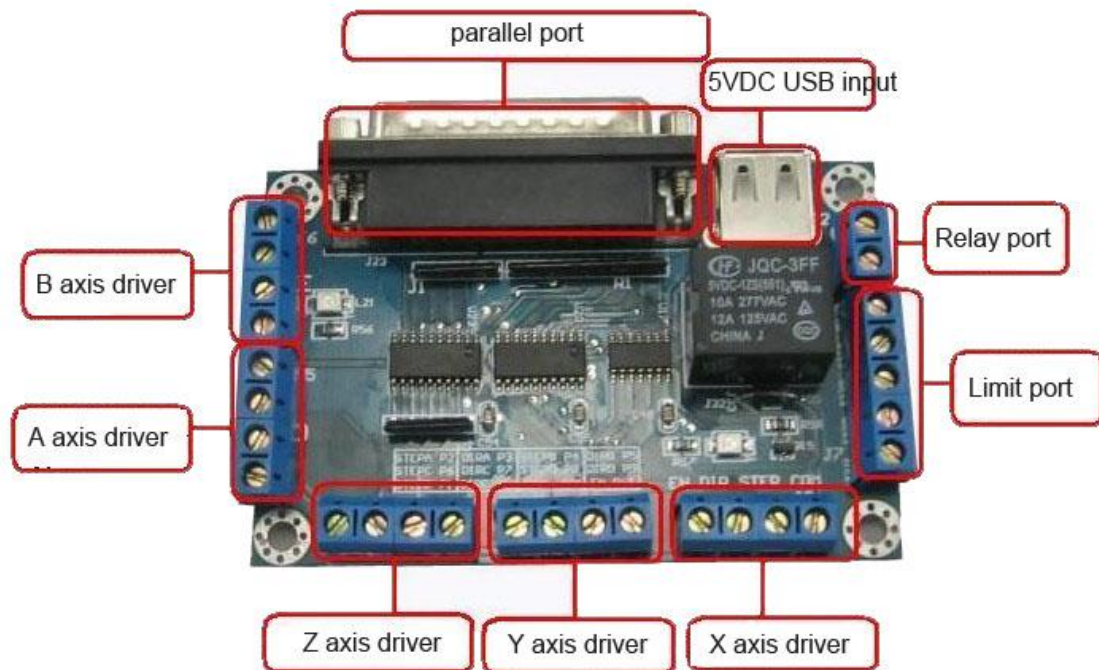

1、 Instruction:

- It can most connection 5pcs driver and control 5pcs motor in the same time
- It is with 4-wire limit switch to insure our safty movement
- It is with relay port to contro the cnc spindle
- Working voltage is 5VDC and support with MACH3,EMC2,KCAM4 software

2、 Breakout board view:



3、 The connection between breakout board and driver :

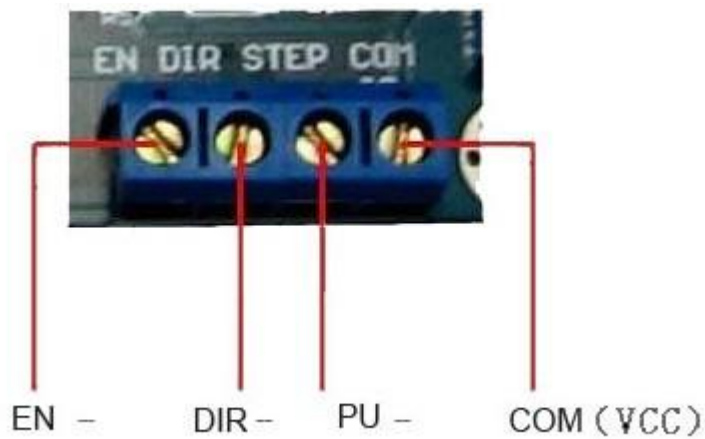

4、 Limit switch port connection :

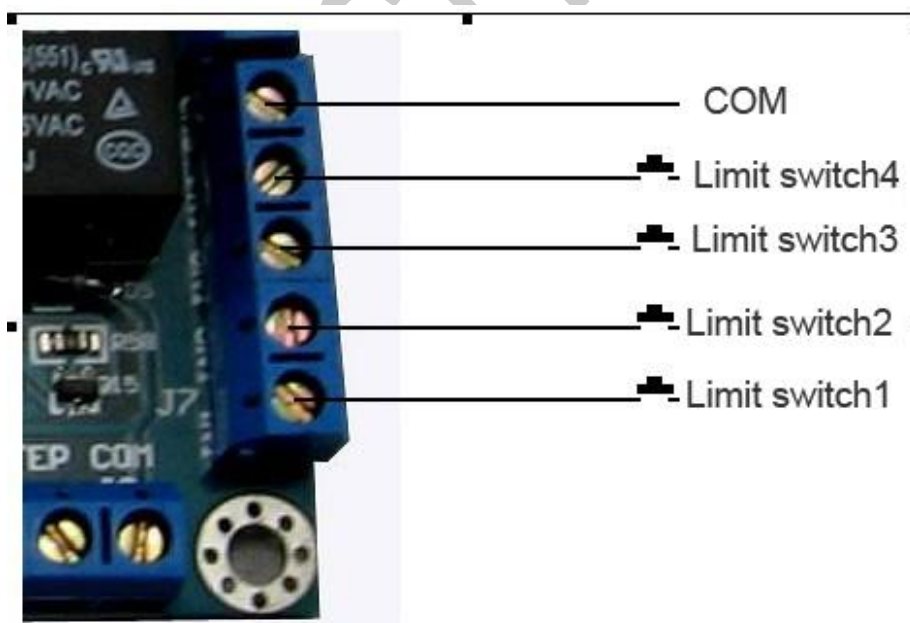

5、 DB25 parallel port definition

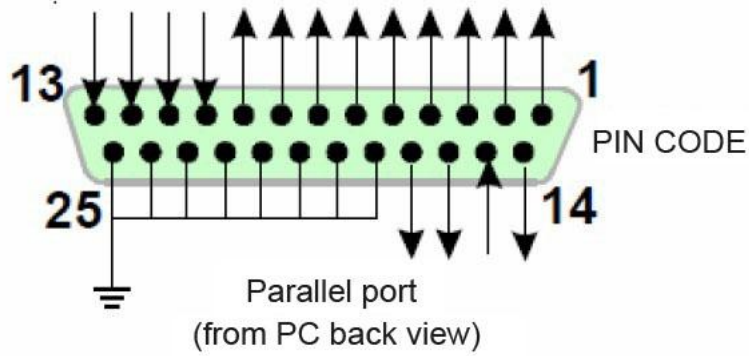

Fig 5.1

Parallel port output PIN definition :

PIN1	PIN2	PIN3	PIN4	PIN5	PIN6	PIN7	PIN8	PIN9	PIN10
STEPE	STEPA	DIRA	STEPB	DIRB	STEPD	DIRC	STEPD	DIRD	DIN1
B axis PU	X axis PU	X axis DIR	Y axis PU	Y axis DIR	Z axis PU	Z axis DIR	A axis PU	A axis DIR	Limit 1
PIN11	PIN12	PIN13	PIN14	PIN17	PIN16	PIN18~25			
DIN2	DIN3	DIN4	DIRE	EN	RLY	GND			
Limit 2	Limit 3	Limit 4	B axis DIR	All axis enable	Relay	GND			

6、Mach3 software setting :

6.1 MACH open :

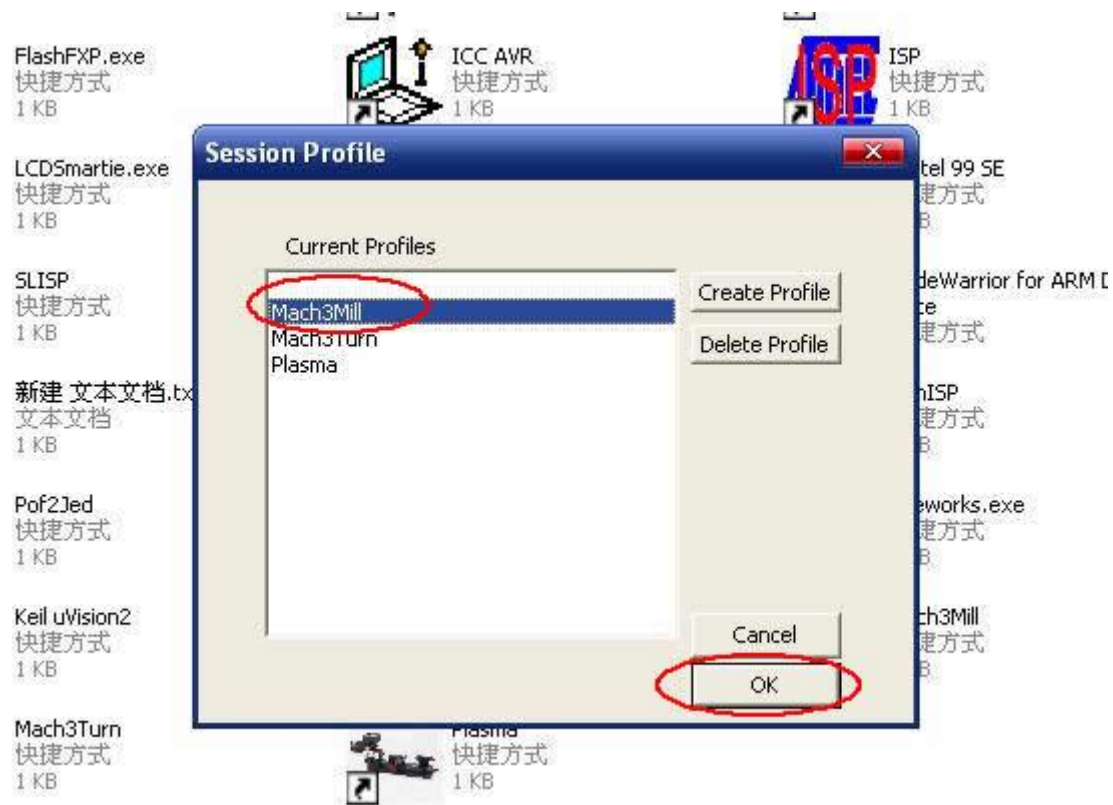

Fig 1

Open MACH3 software , select mach3MILL then click OK

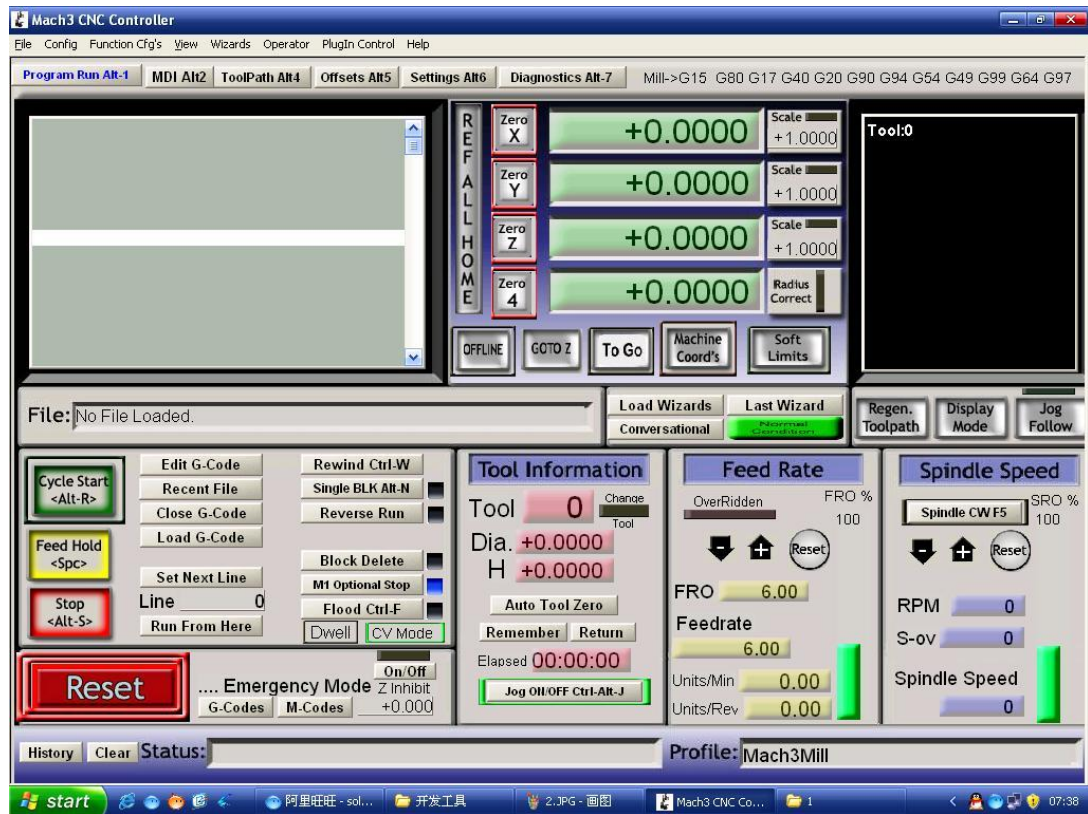

Fig 2 MACH3 interface

6.2、 Driver MACH3 setting :

See Fig 3 , Open the PORT & PINS menu of config menu

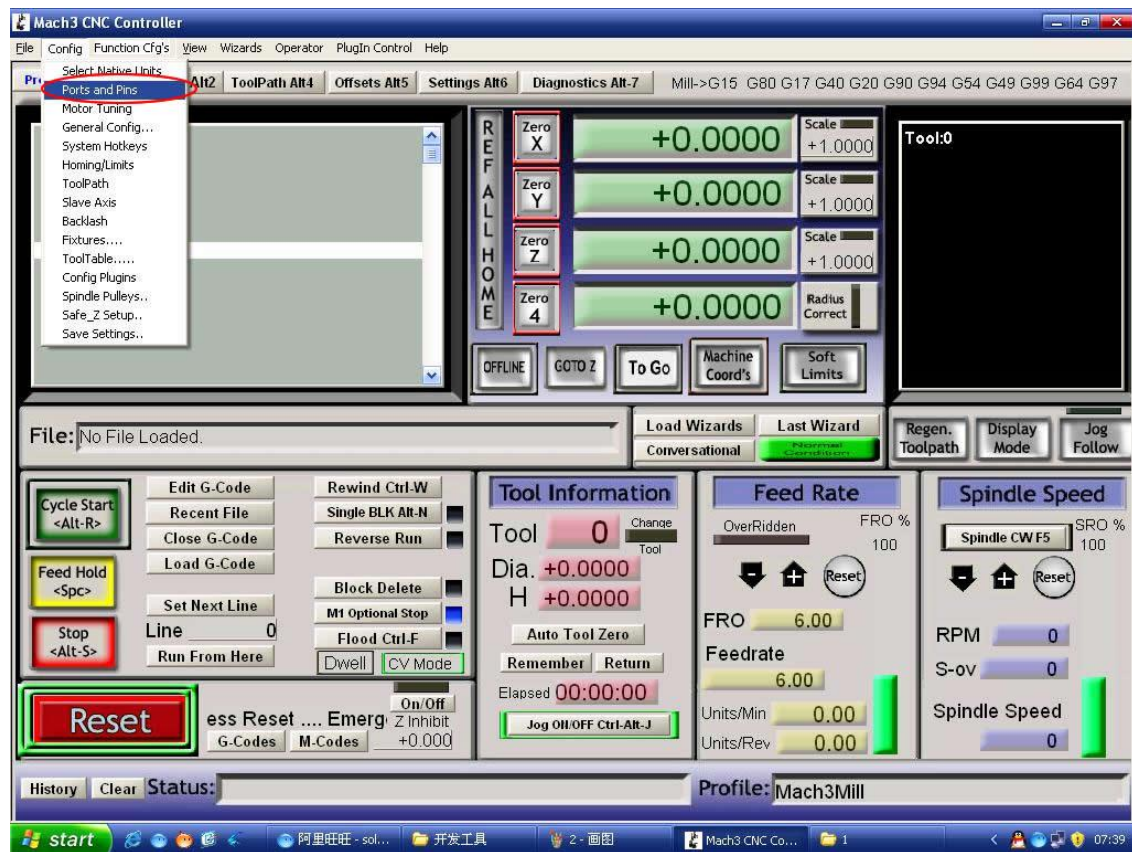

Fig 3

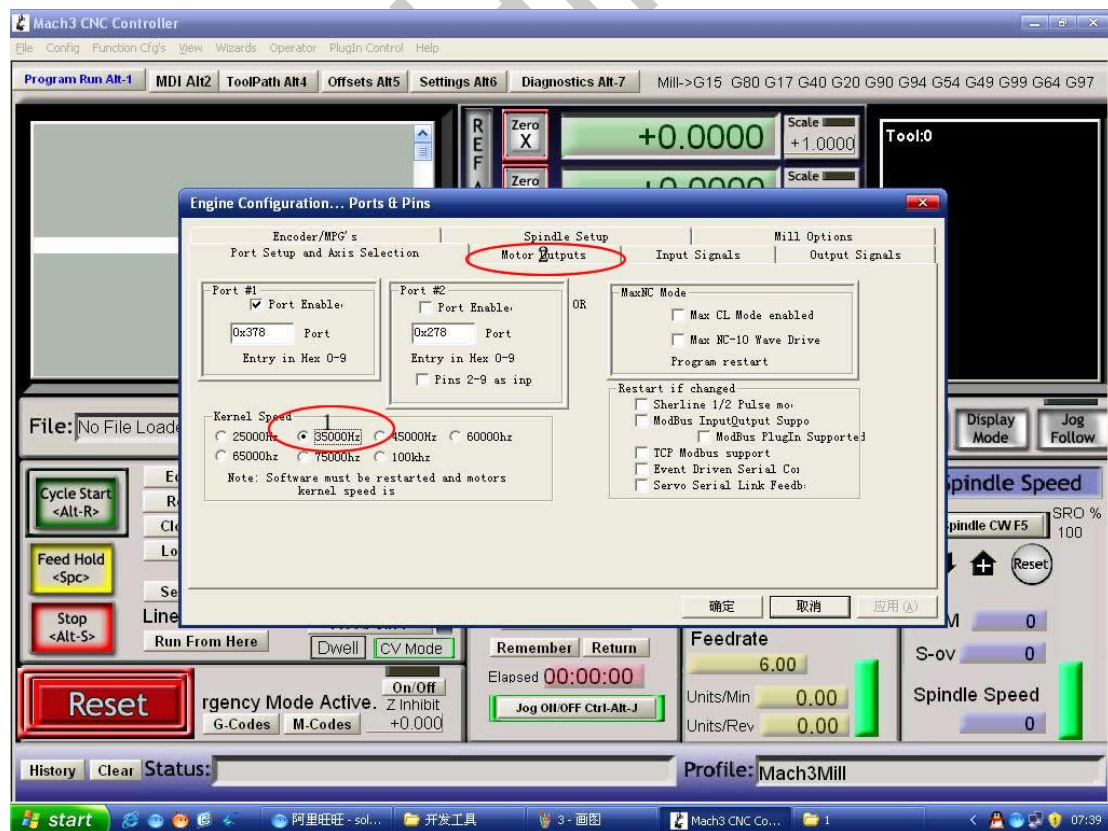

Fig 4

Set up the circle 1 of Fig4 for the frequency which influence the stepper motor speed, then set up the circle 2 as below Fig 5 for PIN

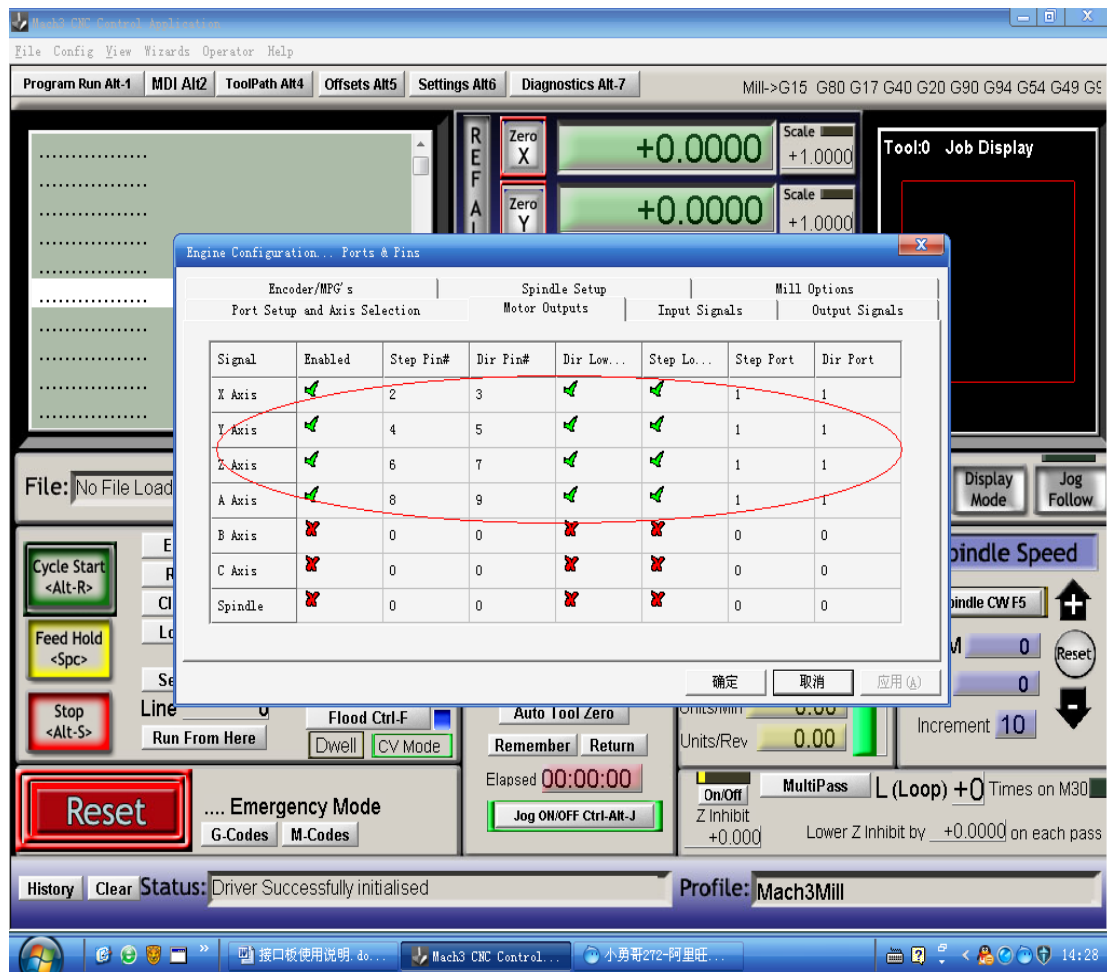

Fig 5

Pls setting the software as above according to our definition of breakout PIN

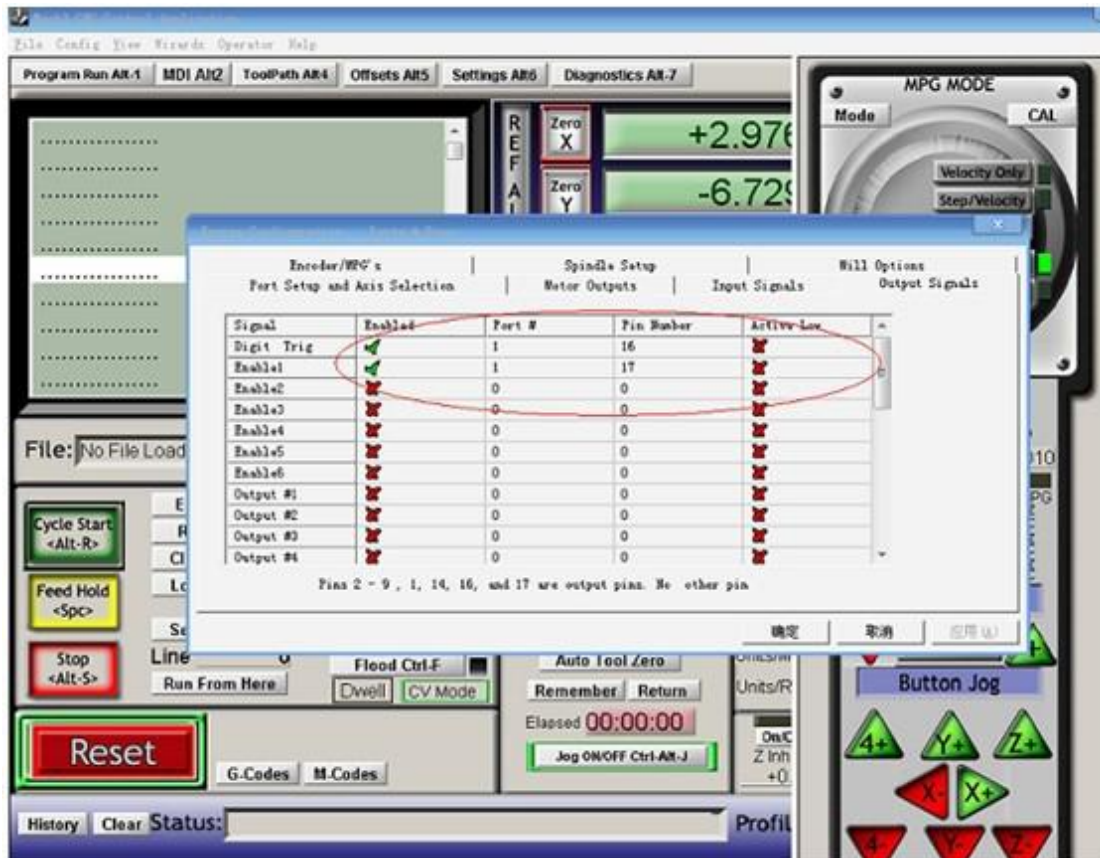

Fig 6

The select “output signals” as Fig 6, set up the pin numer as 16 and 17.

6.3、 Limit switch MACH3 setting :

Click “input signal” to setting as below Fig 7

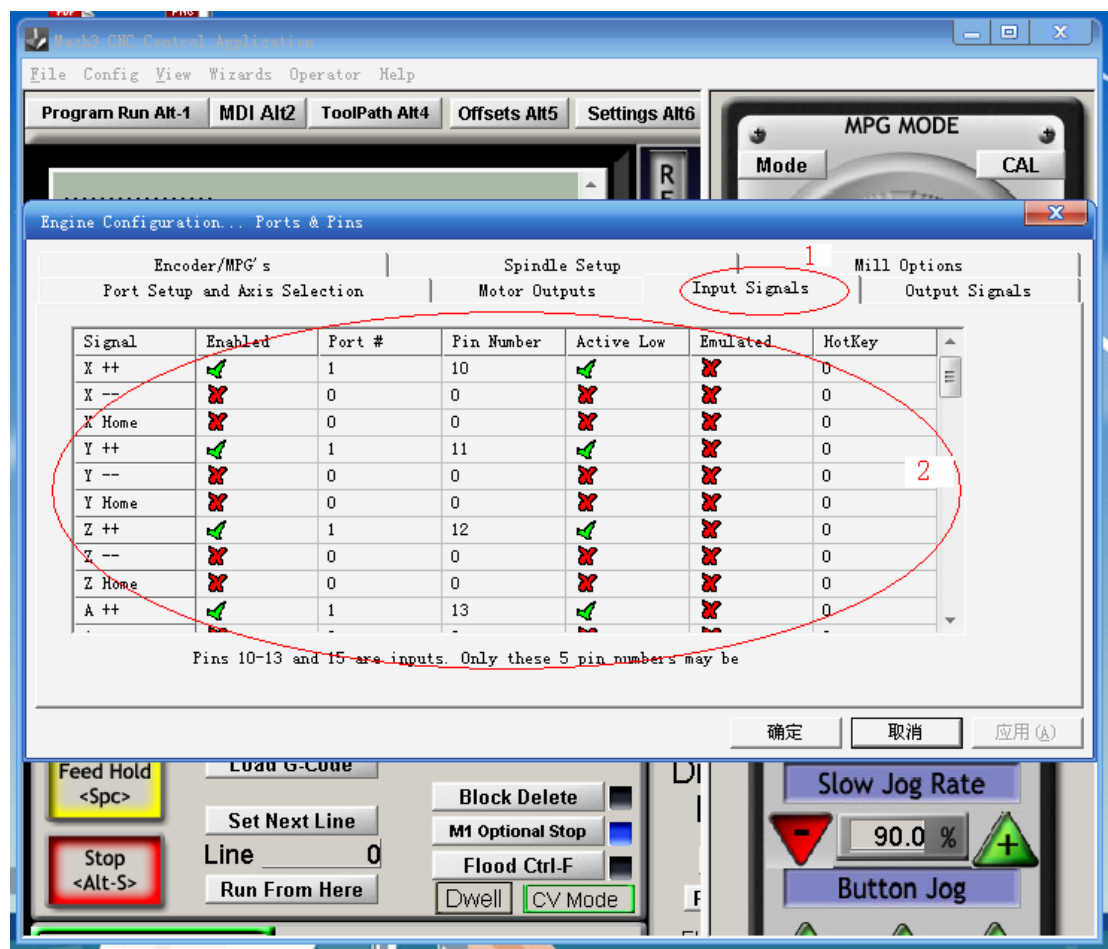

Fig 7

6.4、 Run of the G code :

See Fig 8,open the G code menu

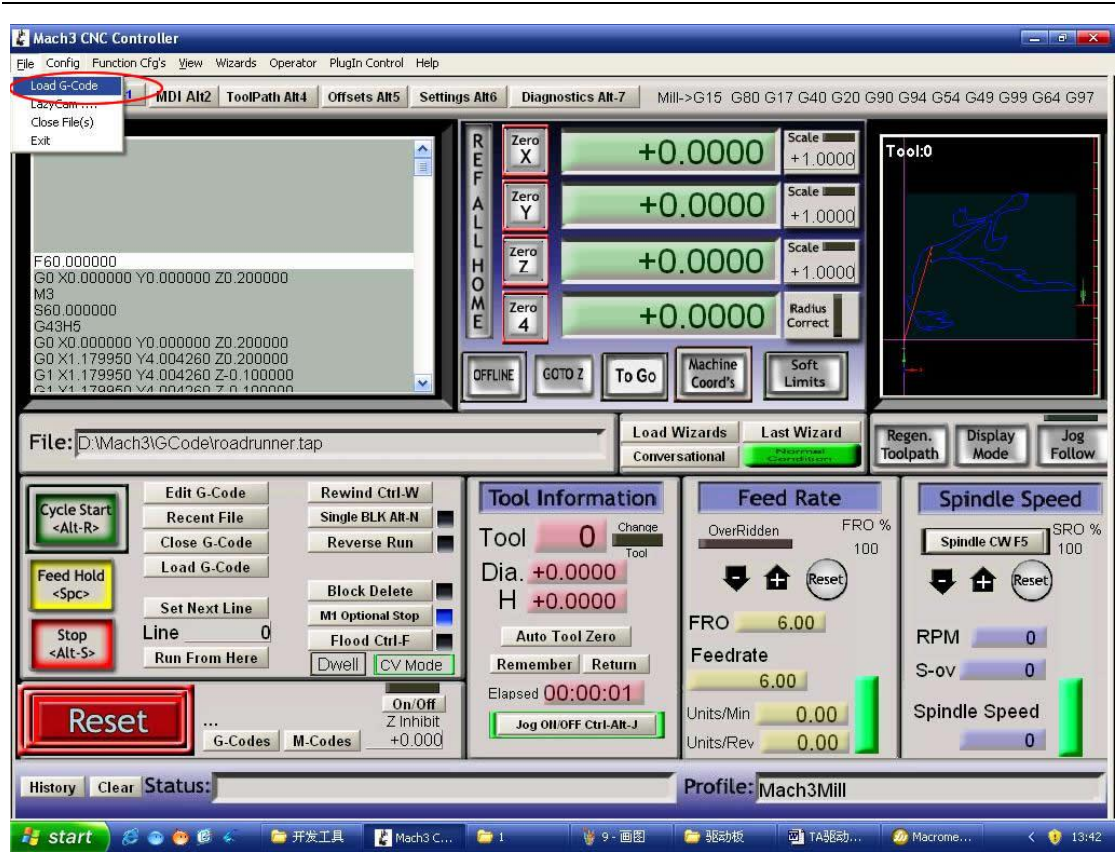

Fig 8

Find your G code, then open as Fig 9:

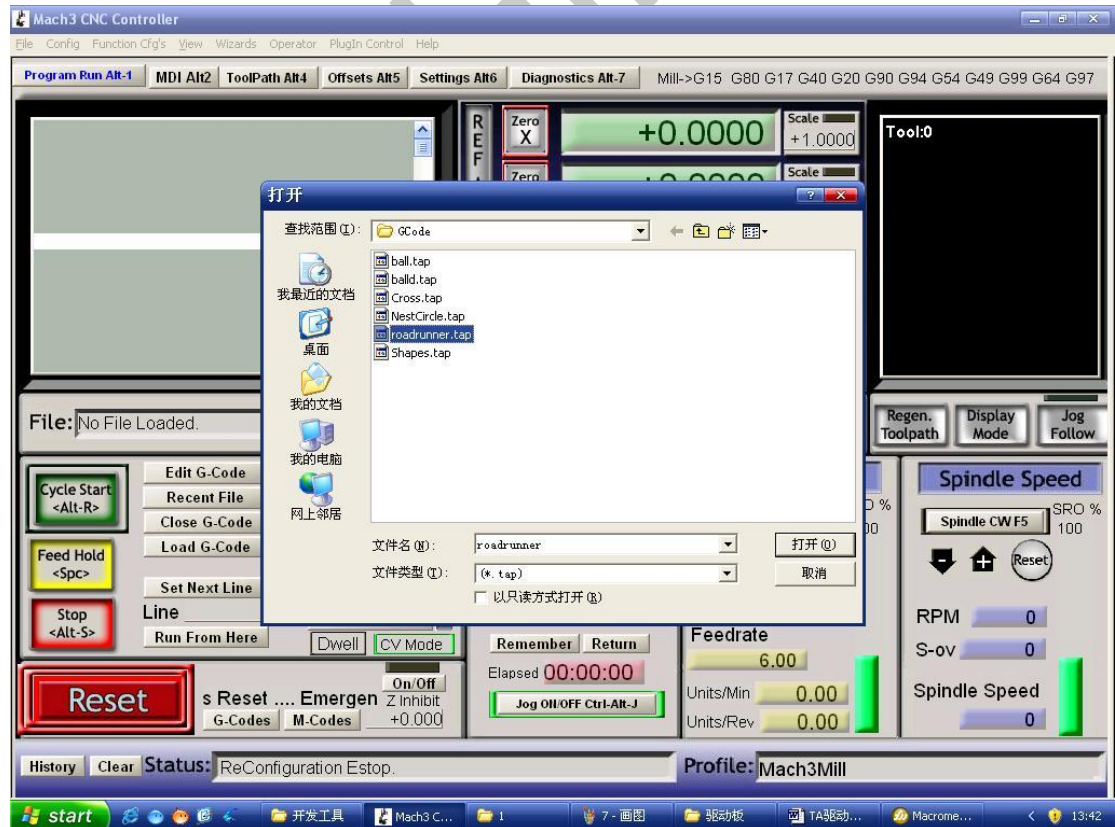

Fig 9

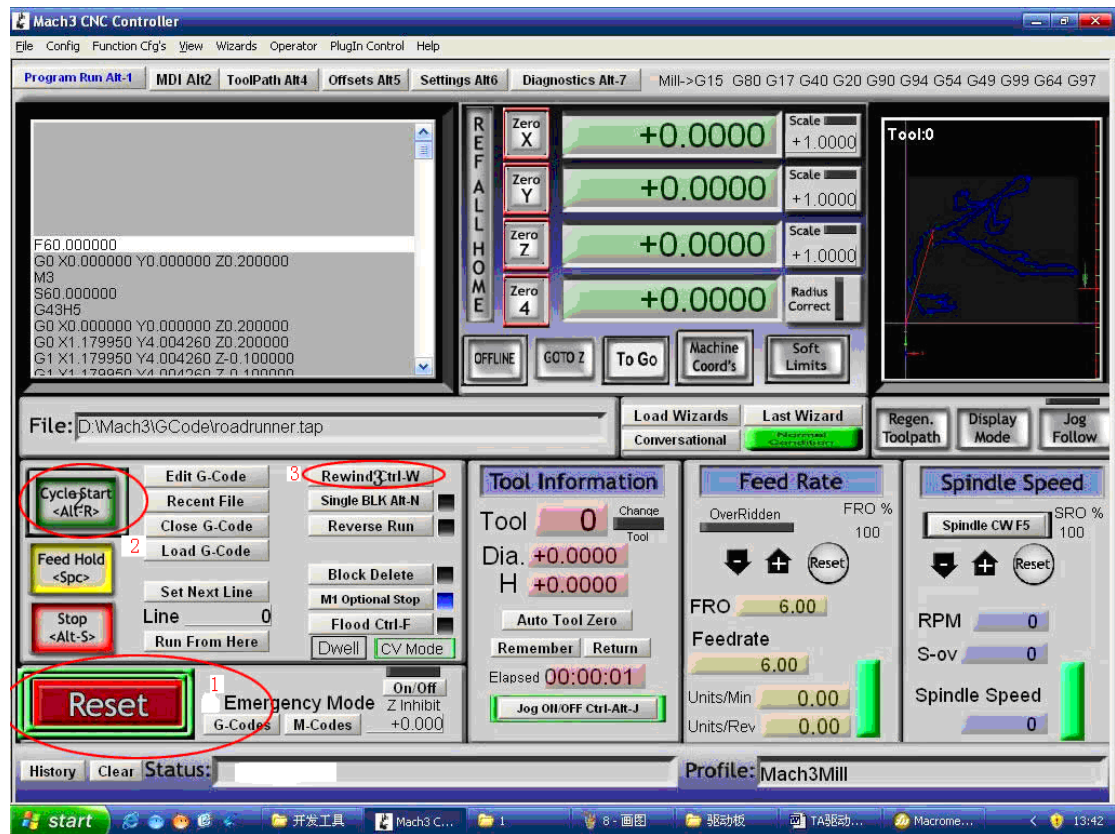

Fig 10

You will see “RESET” flicker after open the G code,you can click it to stop flicker,then run the circle2 “CYCLESTART”
 in addition if you need manual control,you can press the TAB of keyboard,the manual control interface as below Fig 11

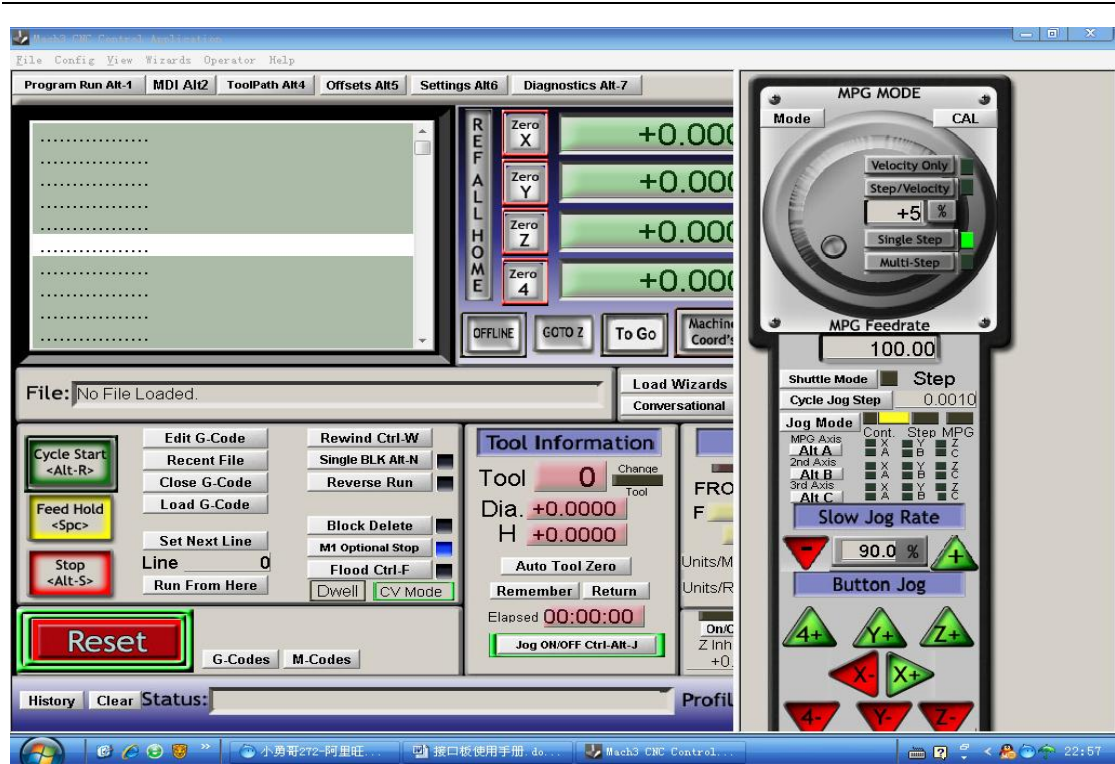

Fig 11

INFOSHINE