

Professional Intelligent Follow Spot

DMX512

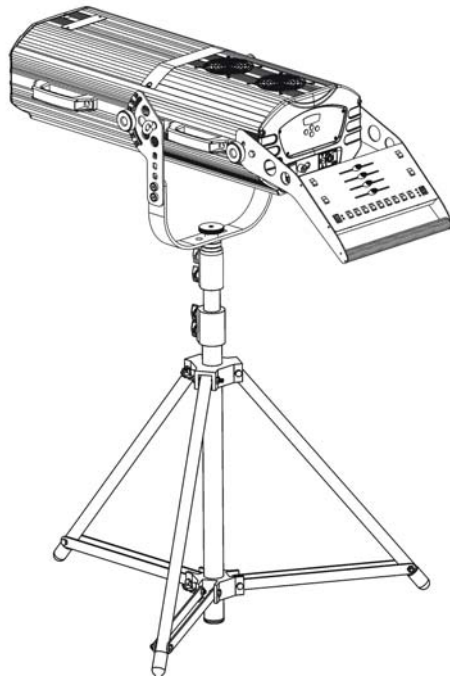

User Guide

Professional Entertainment Technology

TABLE OF CONTENTS

1. Safety Instruction
2. Technical Specification
 - 2.1 Inserting/Exchanging Rotating Gobos
 - 2.2 Beam Angle
3. Lamp
4. How To Set The Unit
 - 4.1 Control Panel
 - 4.2 Main Function
 - 4.3 Home Position Adjust
5. How To Control The Unit
 - 5.1 Universal DMX Controller
 - 5.2 Dedicated Controller
 - 5.3 DMX 512 Configuration
 - 5.4 DMX 512 Connection
6. Troubleshooting
7. Fixture Cleaning

1. Safety Instruction



WARNING

Please read the instruction carefully which includes important information about installation, operation and maintenance.

- ◆ Please keep this User Guide for future consultation. If you sell the unit to another user, be sure that they also receive this user guide.
- ◆ Unpack and check carefully there is no transportation damage before using the unit.
- ◆ Before operating, ensure that the voltage and frequency of power supply match the power requirements of the unit.
- ◆ It's important to ground the yellow/green conductor to earth in order to avoid electric shock.
- ◆ The unit is for indoor use only and only in a dry location.
- ◆ The unit must be installed in a location with adequate ventilation, at least 50 cm from adjacent surfaces. Be sure that no ventilation slots are blocked.
- ◆ Disconnect main power before fuse/lamp replacement or servicing.
- ◆ Replace fuse/lamp only with the same type. Do not use any other type of lamp.
- ◆ Make sure there are no flammable materials close to the unit while operating as it is fire hazard.
- ◆ Use safety cable when fixes this unit. Don't handle the unit by taking its head only, but always by taking its base.
- ◆ Maximum ambient temperature is $t_a: 40^{\circ}\text{C}$. Don't operate it where the temperature is higher than this.
- ◆ Unit surface temperature may reach up to 85°C . Don't touch the housing bare-hand during its operation. Turn off the power and allow about 15 minutes for the unit to cool down before replacing bulb or serving as the unit could be very hot.
- ◆ In the event of serious operating problem, stop using the unit immediately. Never try to repair the unit by yourself. Repairs carried out by unskilled people can lead to damage or malfunction. Please contact the nearest authorized technical assistance center. Always use the same type spare parts.
- ◆ Don't connect the device to any dimmer pack or power pack.
- ◆ Do not touch any wire during operation as high voltage might be causing electric shock.

• Warning

- ◆ To prevent or reduce the risk of electrical shock or fire, do not expose the unit to rain or moisture.
- ◆ Never touch bulb with bare fingers as it is very hot after using.
- ◆ Hot lamp explosion hazard. Do not open the unit within five minutes after switching off.
- ◆ Do not start on the unit without bulb enclosure or housing are damaged.
- ◆ The housing, the lenses, or the ultraviolet filter must be replaced if they are visibly damaged.
- ◆ Do not look directly at the light while the bulb is on.

• Caution

There are no user serviceable parts inside the unit. Do not open the housing or attempt any repairs by yourself. If you need any service, please contact your nearest dealer.

• Installation

The unit should be mounted via its mounting system (as show below). Always ensure that the unit is firmly fixed to avoid vibration and slipping while operating. Always ensure that the structure to which you are attaching the unit is secure and is able to support a weight of 80 kgs for each unit.

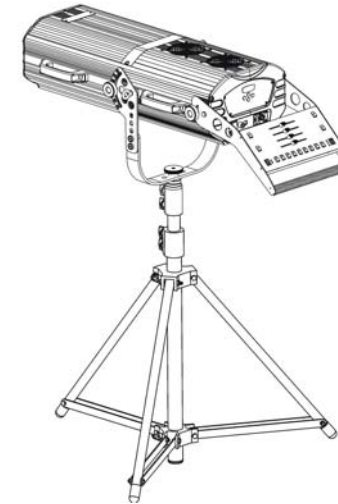

2. Technical Specification

Power supply

- 230V~50/60Hz
- 100V~50/60Hz / 120V~60Hz (Only for IF-575 version)

Lamp

- MSI 1200W/S / HMI 1200/S K SFc10-4
- HMI 575W & HTI 575W (Osram) or HMQ 575 & HMQ 575/2 (Xenpow)

Optical system

- High efficiency optical system
- High quality optical lens and dichroic colors
- Beam angle: 13°

Shutter/Dimmer

- Blackout, 0~100% smooth dimming and strobe speed variable (1~12 flashes per second)

Movement

- Pan: 360° Tilt: 90°

Color Wheel

- 8 dichroic colors plus white color
- Rainbow effect at variable speeds

Color Temperature

- Standard 6000K, adjustable 5600K and 3200K

DMX Channels

- Standard DMX512 signal addressing and controlled by any universal DMX controller

Channel 1 = Shutter
Channel 2 = Iris
Channel 3 = Color
Channel 4 = Color temperature
Channel 5 = Dimmer
Channel 6 = Focus

Luminous intensity: (HMI 1200W)

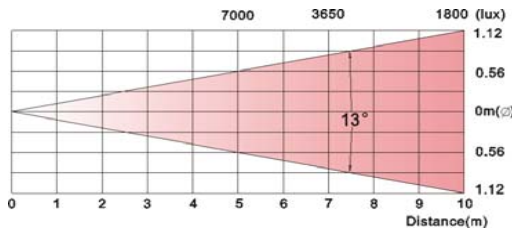

3. Lamp



In case of replacement of the lamp or maintenance, do not open the fixture within 15 minutes until the unit cools down after switching off.

Because of its high internal pressure, there might be a risk that the Discharge lamp would explode during operation. The lamp emits intense UV radiation which is harmful to the eyes and skin. The high luminance of the arc can cause severe damage to the retina if looks directly at the lamp.

MSI 1200W/S / HMI 1200/S K SFc10-4

IF-575: HMI 575W & HTI 575W (Osram) or HMQ 575 & HMQ 575/2 (Xenpow)

1. Always switch off the main supply and never handle the lamp or luminant when it is hot.
2. Do not touch the bulb with bare hands. If this happens, clean the lamp with denatured alcohol and wipe it with a lint free cloth before installation.
3. The lamp generates UV radiation. Never operate the lamp without appropriate shielding.
4. When burning, the lamp operates at high pressure and there is a slight risk of arc tube rupture. The risk increases with age, temperature and improper handling of the lamp. Do not use the lamp any longer than its specified life.
5. Make sure the lamp is located in the center of the reflector for the best spot.

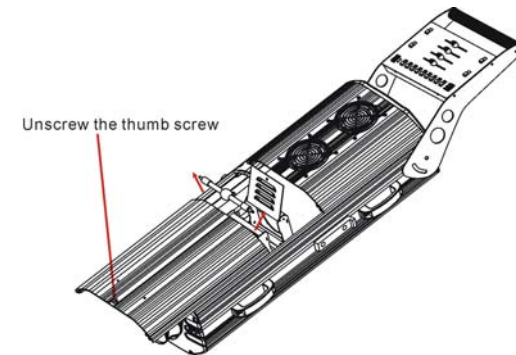

6. If changing the lamp, remove old lamp from lamp socket. Hold the new lamp only by its ceramic base. Never touch the glass bulb. Insert the new lamp in the lamp socket.
7. Please turn the head in horizontal position. Hinge must be on the upper side of the head. Turn screws left and remove plastic cover. Loosen head screw and open the lamp cover

8. With the nipple of the lamp facing the back insert one end of the lamp into the socket. Pull up the spring of the other side of the socket and snap the other end of the lamp into place. Make sure it fits correctly into the socket. Please refer to the diagram to know how to put the lamp in correct position.

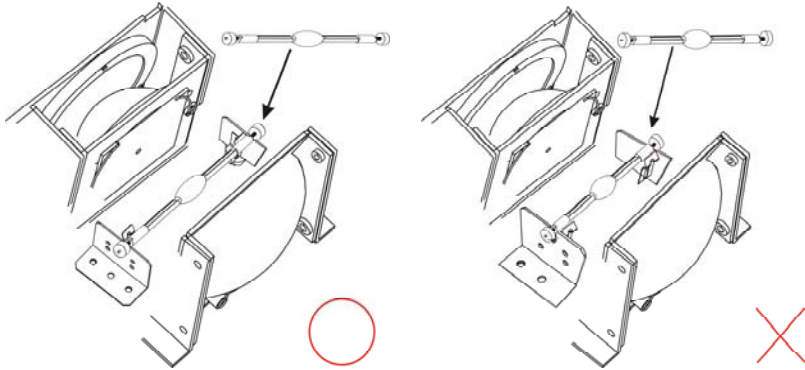

4. How To Set The Unit

4.1 Control Panel

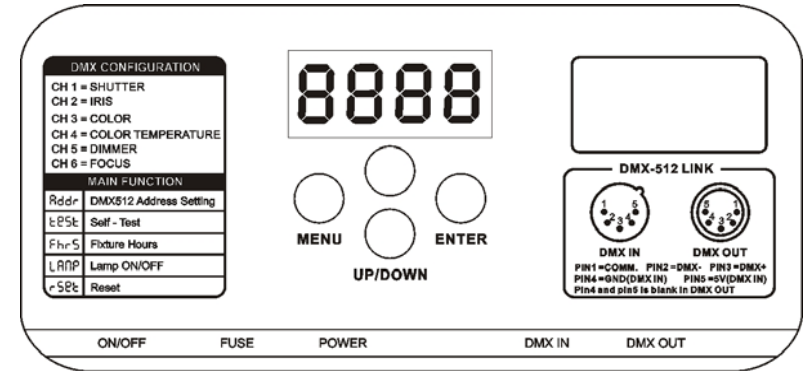

Display

To show the various menu and to select functions.

Button

MENU	To select the programming functions
DOWN	To go backward in the selected functions
UP	To go forward in the selected functions
ENTER	To confirm the selected functions

On/Off

Turns On/Off the power

Fuse

To replace the fuse

Power

To connect the power plug

DMX input/output

For DMX 512 link, use 5-pin XLR plug cable to link the unit together

4.2 Main Function

To select any of the given functions, press the **MENU** button up to when the required one is showing on the display. Select the function by **ENTER** button and the display will blink. Use **DOWN** and **UP** button to change the mode. Once the required mode has been selected, press the **ENTER** button to setup or it will automatically return to the main functions without any change after idling 8 seconds. To go back to the functions without any change press the **MENU** button. The main functions are showing below:

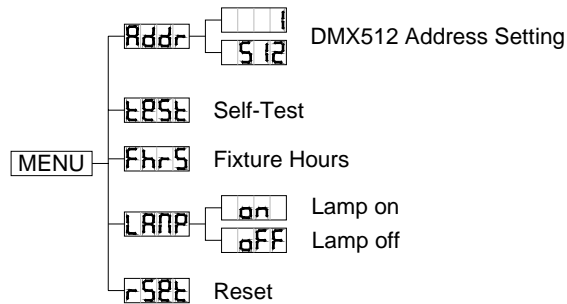

Addr DMX 512 Address Setting

Press the **MENU** button until the **Addr** is showing on the display. Pressing **ENTER** button and the display will blink. Use **DOWN** and **UP** button to change the DMX512 address. Once the address has been selected, press the **ENTER** button to setup or automatically return to the main functions without any change after 8 seconds. To go back to the functions without any change press the **MENU** button again.

TEST Self-Test

Press the **MENU** button until the **TEST** is blinking on the display. Pressing **ENTER** button and the unit will run self-test by built in program. To go back to the functions press the **MENU** button again.

Fhrs Fixture Hours

Press the **MENU** button until the **Fhrs** is blinking on the display. Pressing **ENTER** button and the display will show the number of working hours of the unit. To go back to the functions press the **MENU** button again.

LAMP Lamp ON/OFF

Press the **MENU** button until the **LAMP** is blinking on the display. Pressing **ENTER** button

and the display will blink. Use **DOWN** and **UP** button to select the **on** (Lamp on) or **off** (Lamp off) mode. Once the mode has been selected, press the **ENTER** button to setup or automatically return to the main functions without any change after 8 seconds. To go back to the functions without any change press the **MENU** button again.

rSEt Reset

Press the **MENU** button until the **rSEt** is blinking on the display. Pressing **ENTER** button and all channels of the unit will return to their standard position. To go back to the functions press the **MENU** button again.

4.3 Home Position Adjust

Press **MENU** button for at least 5 seconds into offset mode to adjust the home position, when you want to adjust gobo and color home position, you should be run **rAdJ** mode first, the functions are shown below:

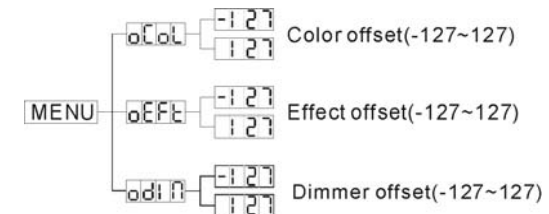

oCol Color offset

Press the **MENU** button for at least 5 seconds into offset mode, use **DOWN** and **UP** button up to when the **oCol** is shown on the display. Pressing **ENTER** button and the display will blink. Use **DOWN** and **UP** button to adjust the color home position. Once the color has been selected, press the **ENTER** button to setup or automatically return to the offset functions without any change press the **MENU** button again, To go back to the main functions without any change after 8 seconds.

oEFF Effect offset

Press the **MENU** button for at least 5 seconds into offset mode, use **DOWN** and **UP** button up to when the **oEFF** is shown on the display. Pressing **ENTER** button and the display will blink. Use **DOWN** and **UP** button to adjust the effect home position. Once the effect has been selected, press the **ENTER** button to setup or automatically return to the offset functions without any change press the **MENU** button again, To go back to the main

functions without any change after 8 seconds.



Dimmer offset

Press the **MENU** button for at least 5 seconds into offset mode, use **DOWN** and **UP** button up to when the  is shown on the display. Pressing **ENTER** button and the display will blink. Use **DOWN** and **UP** button to adjust the dimmer home position. Once the effect has been selected, press the **ENTER** button to setup or automatically return to the offset functions without any change press the **MENU** button again, To go back to the main functions without any change after 8 seconds.

5. How To Control The Unit

Two ways to operate:

1. By universal DMX controller
2. By dedicated controller

No need to turn the unit off when you change the DMX address, as new DMX address setting will be effected at once. Every time you turn the unit on, it will show 575 (IF-575), 1200(IF-1200) on the display and move all the motors to their 'home' position and you may hear some noises for about 20 seconds. After that the unit will be ready to receive DMX signal.

5.1 DMX Controller

If you use a universal DMX controller to control the units, you have to set DMX address from 1 to 512 channels so that the units can receive DMX signal.

Press the **MENU** button up to when the  is shown on the display. Pressing **ENTER** button and the display will blink. Use **DOWN** and **UP** button to change the DMX512 address. Once the address has been selected, press and keep **ENTER** button pressed up to when the display stops blinking or storing automatically 8 seconds later. To go back to the functions without any change press the **MENU** button again.

Please refer to the following diagram to address your DMX512 channel for the first 4 units.

6 Channels : 

5.2

Dedicated Controller

IF-series has 6 channels for international protocol DMX512. It can finish all operations via

dedicated controller without using other controllers. When the power is switched on, the projector automatically starts to run the self-test. After finishing these, the fixture is ready for operation.

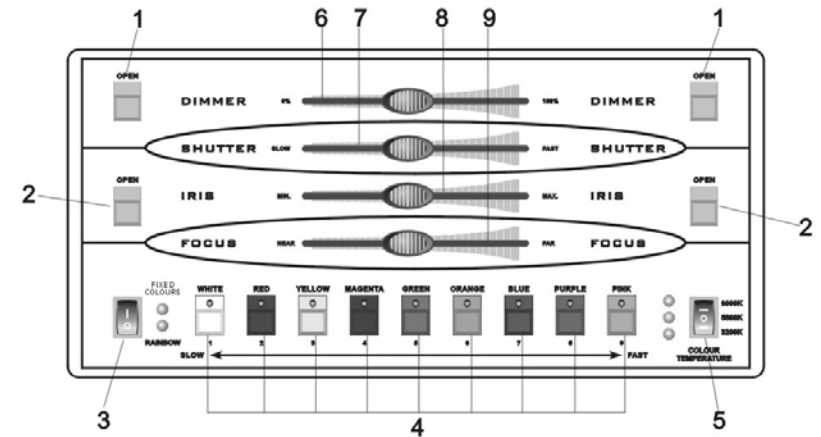

1. **DIMMER OPEN buttons:** Holding the buttons, the light beam will become more stronger and stronger, then shutter will obtain max. value. After un-holding it, the light beam and shutter resumes its initial condition. There are 2 buttons on the both sides of the controller for your convenient operation.
2. **IRIS OPEN buttons:** Holding the buttons, the light iris will become more bigger and bigger. After un-holding it, the light beam resumes its initial condition. There are 2 buttons on the both sides of the controller for your convenient operation.
3. **FIXED COLOURS & RAINBOW switch:** Turning the switch on the RAINBOW position, enable the rainbow function, you can set different rainbow speed by pressing **COLOUR buttons** from slow to fast. Turning the switch on the **FIXED COLOURS** position, enable the fixed colors function and disable the rainbow function. They will save last setting automatically in each step.
4. **COLOUR buttons:** There are 9 color buttons of white, red, yellow, magenta, green, orange, blue, pink and purple. Select the light beam colors by pressing the relative color buttons.
5. **COLOUR TEMPERATURE switch:** Adjusting this switch to obtain 3 kinds of color temperature: Standard 6000K, 5600K and 3200K.
6. **DIMMER slider:** Adjusting the slider from 0% to 100% position, the light beam will become more stronger and stronger till the dimmer reach 100%.
7. **SHUTTER slider:** Adjusting the slider from slow to fast position, the strobe speed will

become from slow to fast.

8. **IRIS slider:** Adjusting the slider from min. to max. position, the light beam size will become more bigger and bigger till the iris opened fully.

9. **FOCUS slider:** Adjusting the suitable focus by pushing this slider from left to right.

DMX-512 Configuration					
Channel 1	Channel 2	Channel 3	Channel 4	Channel 5	Channel 6
Shutter	Iris	Color	Color Temperature	Dimmer	Focus
248-255 Open		255 Fast	171-255 3200K		
247 Fast shutter		 192 Slow 191 Slow 128 Fast 113-127 Pink 099-112 UV purple 085-098 Blue 071-084 Orange 057-070 Green 043-056 Magenta 029-042 Yellow 015-028 Red 000-014 White			
 016 Slow shutter 008-015 Open 000-007 Blackout			000-085 6000K	000 0%	0

5.3 DMX512 Configuration

5.4 DMX512 Connection

The DMX512 is widely used in intelligent lighting control, with a maximum of 512 channels.

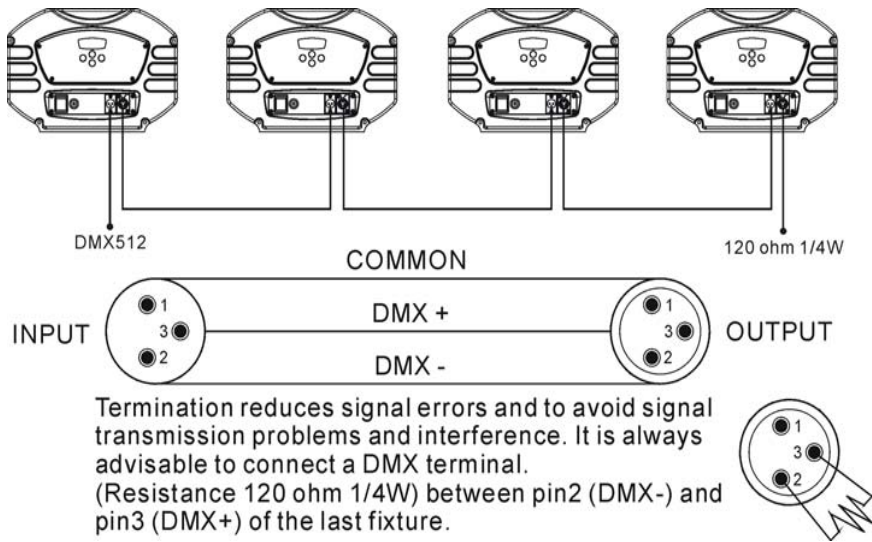

1. If you using a controller with 5 pins DMX output, you need to use a 5 to 3 pin adapter-cable.
2. At last unit, the DMX cable has to be terminated with a terminator. Solder a 120 ohm 1/4W resistor between pin 2(DMX-) and pin 3(DMX+) into a 3-pin XLR-plug and plug it in the DMX-output of the last unit.
3. Connect the unit together in a `daisy chain` by XLR plug from the output of the unit to the input of the next unit. The cable can not branched or split to a `Y` cable. DMX512 is a very high-speed signal. Inadequate or damaged cables, soldered joints or corroded connectors can easily distort the signal and shut down the system.
4. The DMX signal is able to pass through each fixture continuously, so if one fixture in the chain is out of order, all the fixtures after this point will not be affected.
5. Each lighting unit needs to have an address set to receive the data sent by the controller. The address number is between 0-511 (usually 0 & 1 are equal to 1).
6. The end of the DMX512 system should be terminated to reduce signal errors.
7. 3 pin XLR connectors are more popular than 5 pin XLR.
 - 3 pin XLR: Pin 1: GND, Pin 2: Negative signal (-), Pin 3: Positive signal (+)
 - 5 pin XLR: Pin 1: GND, Pin 2: Negative signal (-), Pin 3: Positive signal (+)

6. Troubleshooting

Following are a few common problems that may occur during operation. Here are some suggestions for easy troubleshooting:

A. The unit does not work, no light and the fan does not work

1. Check the connect power and main fuse.
2. Measure the mains voltage on the main connector.
3. Check the power on LED.

B. Not responding to DMX controller

1. Check the address settings and DMX polarity.
2. If you have intermittent DMX signal problems, check the pins on connectors or on PCB of the unit or the previous one.
3. Try to use another DMX controller.
4. Check in the DMX cables run near or run alongside to high voltage cables that may cause damage or interference to DMX interface circuit.

C. One of the channels is not working well

1. The stepper motor might be damaged or the cable connected to the PCB is broken.
2. The motor's drive IC on the PCB might be out of condition.

D. The lamp is cutting out intermittently

1. The lamp is not working well. Check the main voltage either too high or too low.
2. Internal temperature may be too high. Check and if necessary replace the fan.

7. Fixture Cleaning

The cleaning of internal and external optical lenses and/or mirrors must be carried out

periodically to optimize light output. Cleaning frequency depends on the environment in which the fixture operates: damp, smoky or particularly dirty surrounding can cause greater accumulation of dirt on the unit's optics.

- Clean with soft cloth using normal glass cleaning fluid.
- Always dry the parts carefully.
- Clean the external optics at least every 20 days. Clean the internal optics at least every 30/60 days.

EC - Declaration of Conformity

We declare that our products (lighting equipments) comply with the following specification and bears CE mark in accordance with the provision of the Electromagnetic Compatibility (EMC) Directive 89/336/EEC.

EN55014-2: 1997 A1:2001, EN61000-4-2: 1995; EN61000-4-3:2002;
 EN61000-4-4: 1995; EN61000-4-5: 1995, EN61000-4-6:1996,
 EN61000-4-11: 1994.

&

Harmonized Standard

EN 60598-1: 2004
 IEC 60598-1:2003+ corrigendum 2004
 Part 1:General requirements and test

Following the provisions of the low voltage directive 73/23/EEC and 93/68/EEC

Power	AC 230V~50/60Hz AC 100V~50/60Hz or 120V~60Hz (only for HMI 575W version)
Fuse	6 x 30 mm Glass T15A (HMI-1200W version) 6 x 30 mm Glass T10A (HMI 575W version)
Lamp	MSI 1200W/S / HMI 1200/S K SFc10-4/ HMI 575W
Dimension	1170 x 330 x 225 mm 405 x 360 x 35 mm (Controller)
Weight	42.4 kg (HMI-1200W version) 38 kg (HMI 575W version)