

AN11308

Quick Start Up Guide PNEV512B Board

Rev. 1.9 — 11 November 2015
255019

Application note
COMPANY PUBLIC

Document information

Info	Content
Keywords	PN512, Blueboard, LPCXpresso, MCU, Code Red, eclipse, LPC1769, LPC1227, NFC Reader Library, PNEV512B
Abstract	This application note is related to the installation procedures of the PNEV512B Board. It describes the actions to be done to become acquainted with the demo reader



Revision history

Rev	Date	Description
1.9	20151111	Updated all relevant parts in respect to the NFC Reader Library update Removed LPC1227 support
1.8	20141201	Added a note about RAM limitation of LPC1227.
1.7	20140721	Small corrections
1.6	20140519	Removed the note about the version of the LPCXpresso IDE. Some small corrections. Changed the description and pictures of the projects Polling and, Classic Changed the P2P description due to a software update. Removed the description about the projects Ultralight and DESFire. All projects are now based on the NFC Reader Library version 3.010. Therefore all projects have been refactored. Added support for the development board LPCXpresso LPC1769 which is based on an ARM Cortex M3 microcontroller. The NFC Reader Library is now called NFC Reader Library
1.5	20140114	Added description for Card Emulation T4T and T2T.
1.4	20131011	Added info about what version of the LPCXpresso IDE to use.
1.3	20130613	Added description about the P2P Snep Client
1.2	20130221	Added description of the P2P project. Added information about the use of the projects in conjunction with the LPC1227 MCU. Added information about the documentation of the NFC Reader Library. Added information about the exemplary project of code size optimization of the NFC Reader Library.
1.1	20130108	Red circles of some figures corrected
1.0	20121217	First release

Contact information

For more information, please visit: <http://www.nxp.com>

For sales office addresses, please send an email to: salesaddresses@nxp.com

1. Introduction

This application note gives a detailed overview of the hardware for working with the PN512 contactless reader IC, we use the LPCXpresso LPC 1769 and the Blueboard (**Chapter 2**), the installation procedures of the Development Environment (**Chapter 4.1**) and the handling of the reader projects using the NFC Reader Library (**Chapter 0**).

The projects used and explained in this documentation are:

Table 1. Example projects

Example projects delivered with the NFC Reader Library

Example	Description
Example 1 – Basic Discovery Loop	Explains how to poll for different technologies (Tag, P2P, HCE), detect and report them. Default configuration parameters are used.
Example 2 – Advanced Discovery Loop	Explains how to poll for different technologies (Tag, P2P, HCE), detect and report them. All configuration parameters are used and explained.
Example 3 – NFC Forum	Explains how to configure the NFC Reader Library for different P2P modes such as Active Mode, Target Mode, Initiator Mode and SNEP Client/Server.
Example 4 – MIFARE Classic	Explains the usage of standard MIFARE commands.
Example 8 – HCE T4T	Explains how to emulate a NFC Forum Type 4 Tag supporting read and write operations.
Example 9 – NTAG-I2C	Explains NTAG-I2C specific commands.

2. Hardware overview of the Demo Reader

The demo reader is made up of 2 separate boards:

- A PNEV512B demo board provided by NXP (12NC: 9352 981 99699). This board has connectors which are designed to exactly fit the ones of the companion LPCXpresso LPC 1769 development boards.
- A commercial LPCXpresso LPC 1769 development board (12NC: 935291912598, Type: OM13000+598) which can be provided by NXP or bought directly on the market. See Ref. [\[11\]](#).

Once the two boards are put together via the connectors, the demo reader is ready for use.

2.1 PNEV512B demo board

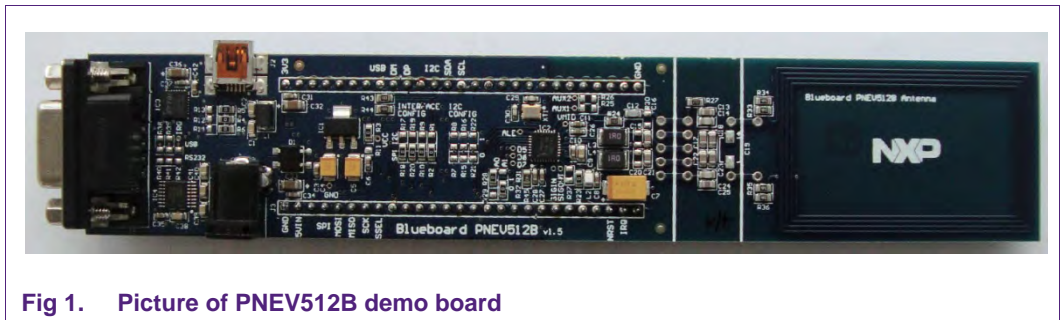

Fig 1. Picture of PNEV512B demo board

The PNEV512B demo board embeds the contactless communication transceiver IC PN512 with all its elements needed for transmission: EMC filter, matching network and the antenna. The PN512 supports different kind of contactless communication methods and protocols at 13.56 MHz:

- Reader/Writer mode supporting ISO/IEC 14443A/MIFARE and FeliCa scheme
- Reader/Writer mode supporting ISO/IEC 14443B
- Card Operation mode supporting ISO/IEC 14443A/MIFARE and FeliCa scheme
- NFCIP-1 mode
- Refer to the data sheet of this IC [\[2\]](#) for more details

Thanks to the relevant solder bridges, the host link of the PNEV512B demo board can be configured for:

- I²C
- SPI
- UART (optional, see Section [2.7](#))



Fig 2. Picture of solder bridges in default configuration

The default interface configuration of the PNEV512B demo board is SPI. The detailed interface configuration is described in section 2.7.

Additional interface and power supply options are described in section 2.8.

2.2 CE certification of the Blueboard

The current version of the demo board (v.1.5) is CE (European Conformity) compliant.

2.3 LPCXpresso LPC1769 development board

To work with the provided projects, one will also need an LPCXpresso LPC development board. Such a board is **not included** in the Blueboard hardware package.

The LPC1769 development board integrates an NXP ARM Cortex-M3 microcontroller LPC1769 with 512 Kbytes of Flash memory and 64 Kbytes of RAM. It integrates a lot of hardware parts:

- Serial UART interface,
- SPI controller,
- I²C controller,
- Serial Wire test/debug interface,
- For detailed information, see LPC1769 product site [\[3\]](#)

The LPCXpresso board contains a JTAG/ SWD debugger called the “LPC-Link” and a target MCU. LPC-Link is equipped with a 10-pin JTAG header and it seamlessly connects to the target via USB (the USB interface and other debug features are provided by NXP’s ARM9 based LPC3154 MCU).



Fig 3. Picture of LPCXpresso LPC1769 development board

2.4 Preparation of the hardware

The first step after unpacking the Blueboard and the LPCXpresso is soldering the connectors onto the boards to get them together. In our example we use a multipoint connector as one can see on the pictures below.

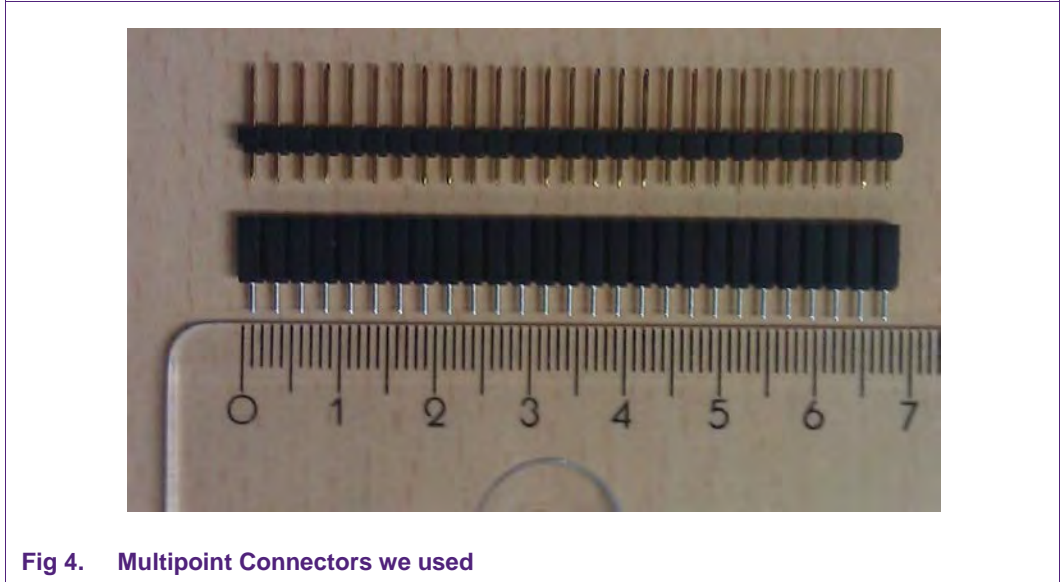

Fig 4. Multipoint Connectors we used

One may buy these connectors at any electronic store. Here are some examples [\[4\]](#). After soldering the connectors, join the boards as shown on the following figure.

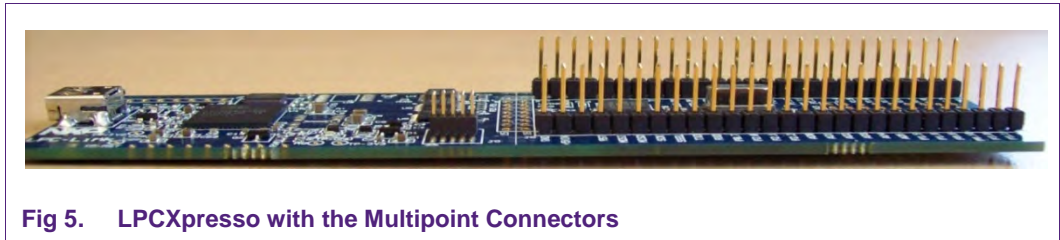

Fig 5. LPCXpresso with the Multipoint Connectors

Now the hardware is ready for use. Please connect the LPCXpresso board with the Blueboard.

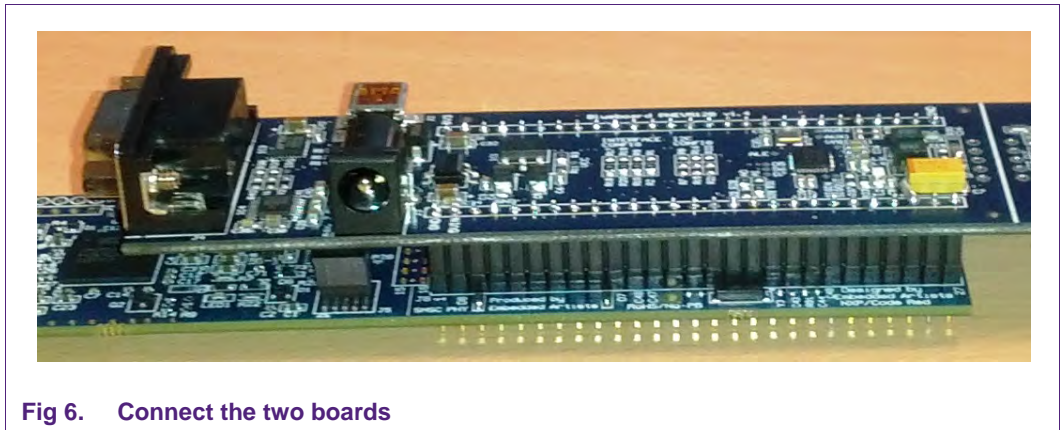

Fig 6. Connect the two boards

2.5 Soldering the interrupt connection

To get the interrupt working, please connect the pins 26 and 27 of the PNEV512B board.

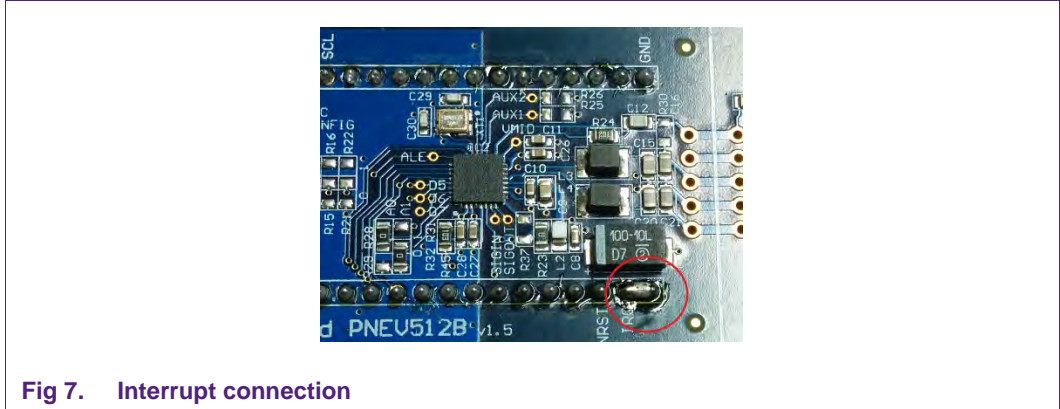

Fig 7. Interrupt connection

2.6 Interesting points of measurement

On the PNEV512B demo board one can find test pads for measurement purposes.

- VCC
- GND
- D5
- D6
- D7
- ALE
- AUX1
- AUX2
- SIGIN
- SIGOUT
- IRQ
- VMID

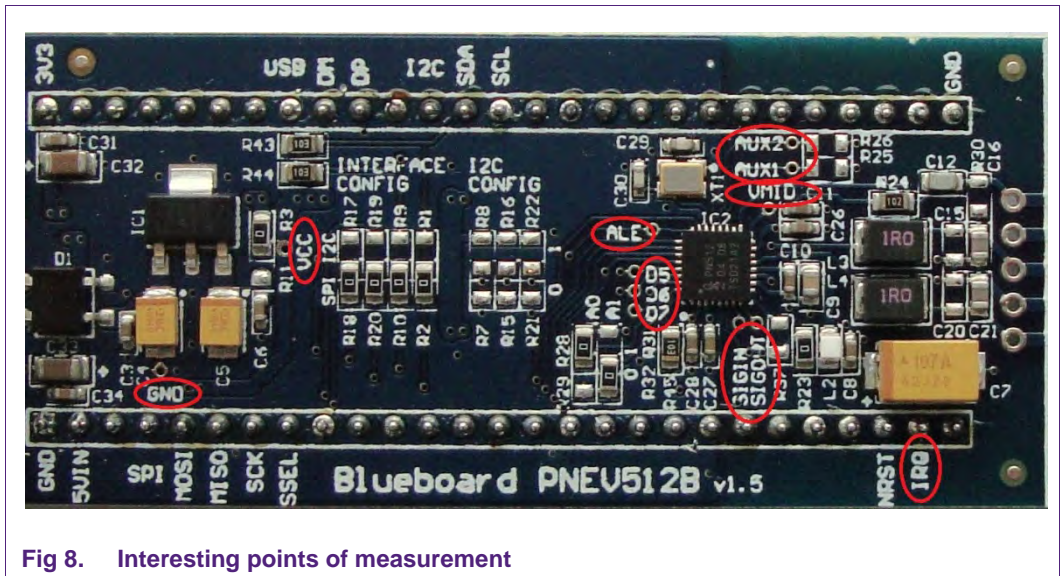

Fig 8. Interesting points of measurement

2.7 Preparing the Blueboard for the use with SPI or I²C

The Blueboard is generally delivered in SPI configuration. To change the interface to I²C the four appropriate 0R0 resistors in the interface config section need to be resoldered to

the I²C side of the solder jumpers. Also the two 0R0 resistors at A0 and A1 need to be changed.

Table 2. A0 and A1 interface configuration

Appropriate solder jumpers (0R0 resistors) for interface configuration

Signal	Interface type		
	SPI	I ² C	UART(optional)
A0	R28	R29	R29
A1	R32	R31	R32

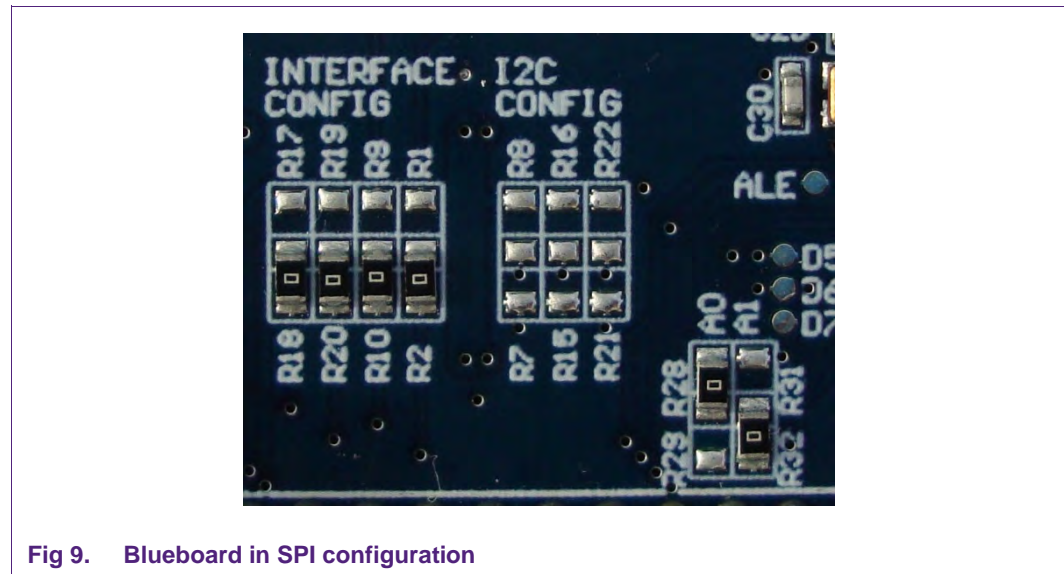

Fig 9. Blueboard in SPI configuration

To use the Blueboard in I²C configuration with the provided software projects, one has to carry out two minor adaptations in the code, which are described in section 6.5.

The I²C-address can be configured either by software or by hardware. To set the I²C-address by hardware the solder jumpers in the I²C config section (see picture above) have to be connected appropriately. R7, R15 and R24 are logically LOW and R8, R16 and R22 logically HIGH.

2.8 Optional interfaces and power supply

The PNEV512B demo board is normally controlled by the LPCXpresso Board. With the optional interfaces and power supply the demo board can be controlled directly by a PC without the LPCXpresso Board.

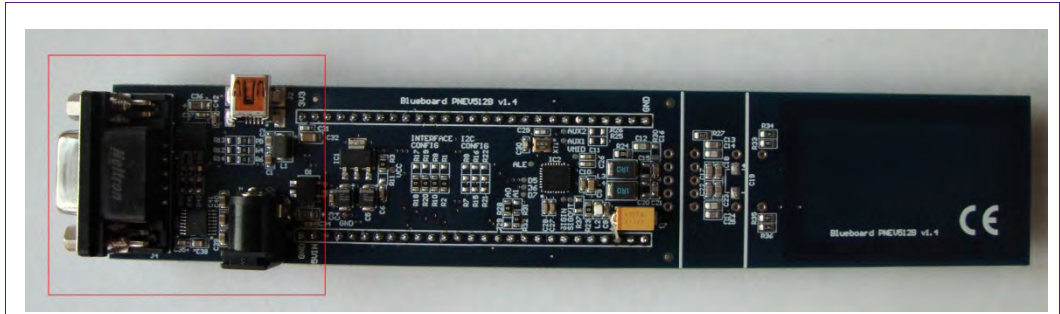

Fig 10. Additional interfaces

To use the additional interfaces the interface selection signals A0 and A1 have to be configured to UART mode (see section 2.7, Table 2).

2.8.1 Configuring the additional interfaces

With the appropriate solder jumpers two different serial interfaces can be selected.

Table 3. Solder Jumpers for selecting the additional interfaces

Interface type	Resistors
USB	R38, R39
RS232	R40, R41, R42

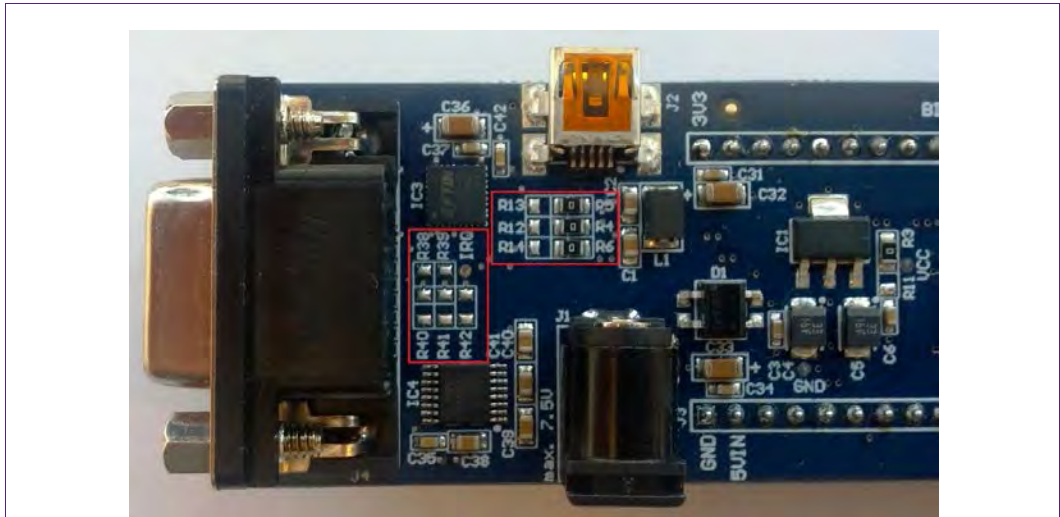

Fig 11. Solder jumpers for additional interface configuration

In delivery default configuration the USB-connector of the PNEV512B demo board is directly routed to the USB-pins of the LPCXpresso Board μ C in order to use the USB connector as an additional USB connector of the LPCXpresso Board.

For using the USB interface in UART mode the following solder jumper configuration is needed:

Table 4. Solder Jumpers for USB connector configuration

Connection type	Resistors
LPCXpresso-USB	R4, R5, R6
UART-USB	R12, R13, R14

2.8.2 Configuring the power supply

When using the PNEV512 demo board without the LPCXpresso Board an additional 5VDC power supply is needed. The onboard voltage regulator provides the 3.3VDC supply voltage VCC.

Table 5. VCC power supply configuration

Power supply	Resistors
LPCXpresso Board	R3
External 5VDC	R11

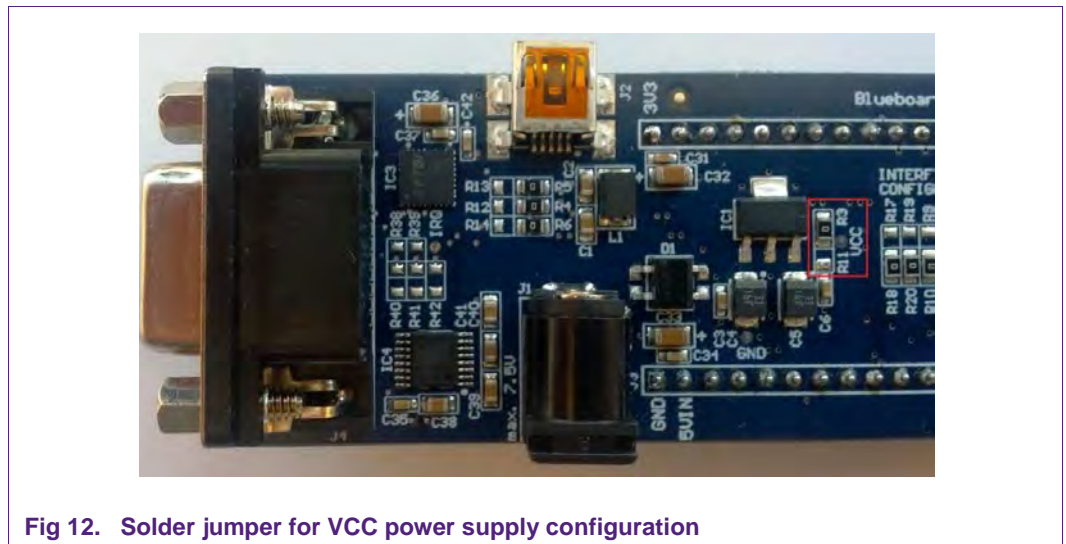

Fig 12. Solder jumper for VCC power supply configuration

2.9 Other supported system architectures

The projects described in this guide are also available on Linux. The projects are preconfigured for the use on the Raspberry Pi with the Raspbian image. The SPI interface is used for the communication between the application and the NFC controller. The software and the start guide can be downloaded at the product page of the EXPLORE-NFC [\[12\]](#).

Although this guide only describes the use of the EXPLORE-NFC extension board, it also supports the PNEV512B Blueboard. The Blueboard can be used with a special adaptor called BluePi. For information about how to configure the hardware and the software please refer to section [6.7](#).

3. Installation of the LPCXpresso Board

The guidelines for installing the reader are as follows:

- Connect the LPCXpresso Board to a real USB2.0 port of the PC (for speed reasons) using the mini-USB connector. The PC detects and installs the Board automatically.

Once the Board has been installed, open the Device Manager of the PC to check that the installation was successful. The item “USB Device with DFU Capabilities” is being displayed.

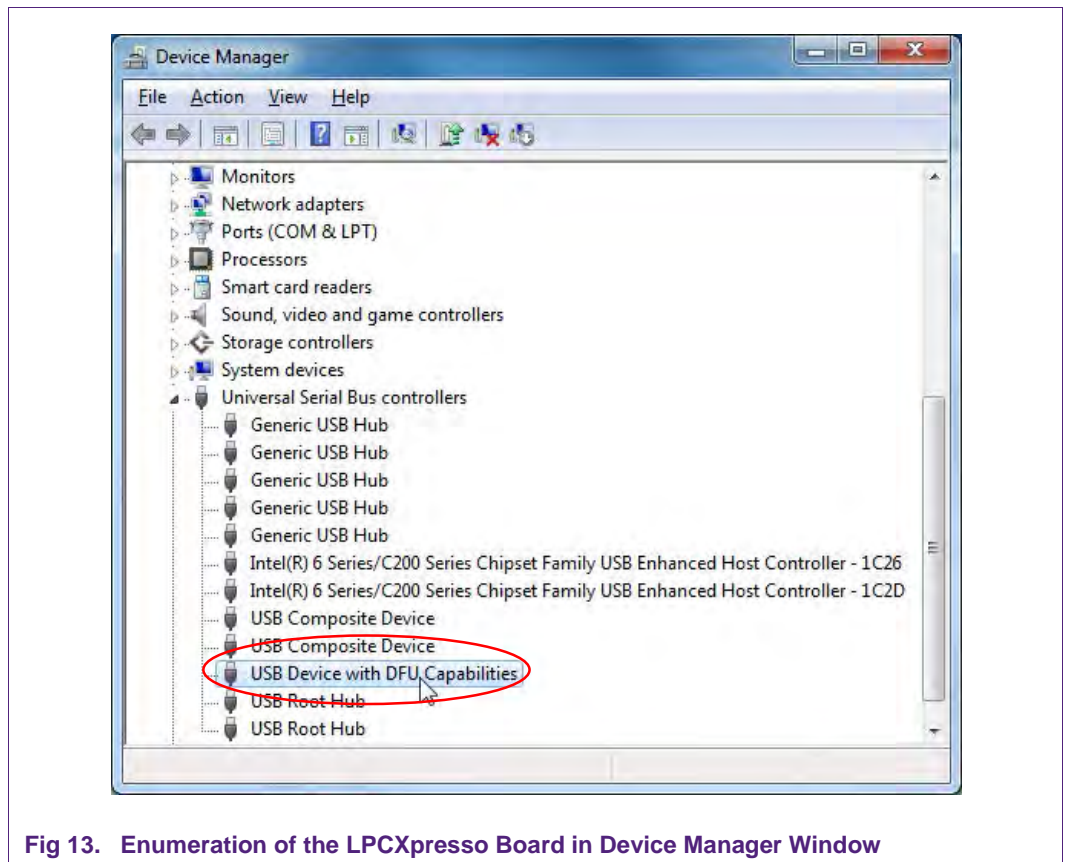

Fig 13. Enumeration of the LPCXpresso Board in Device Manager Window

4. Managing the Demo Reader project with LPCXpresso IDE

The demo reader project is delivered in a zip package. It can be extracted, edited, compiled and linked with LPCXpresso IDE.

LPCXpresso is a new, low-cost development platform available from NXP. It supports NXP's ARM-based LPC microcontrollers. The platform is comprised of a simplified Eclipse-based IDE and low-cost target boards which include an attached JTAG debugger.

This tool can freely be downloaded from the LPCXpresso website [1].

4.1 Installation of LPCXpresso IDE

The IDE is installed into a single directory of one's choice. Multiple versions can be installed simultaneously without side effects. The installation starts after double-clicking the installer file.

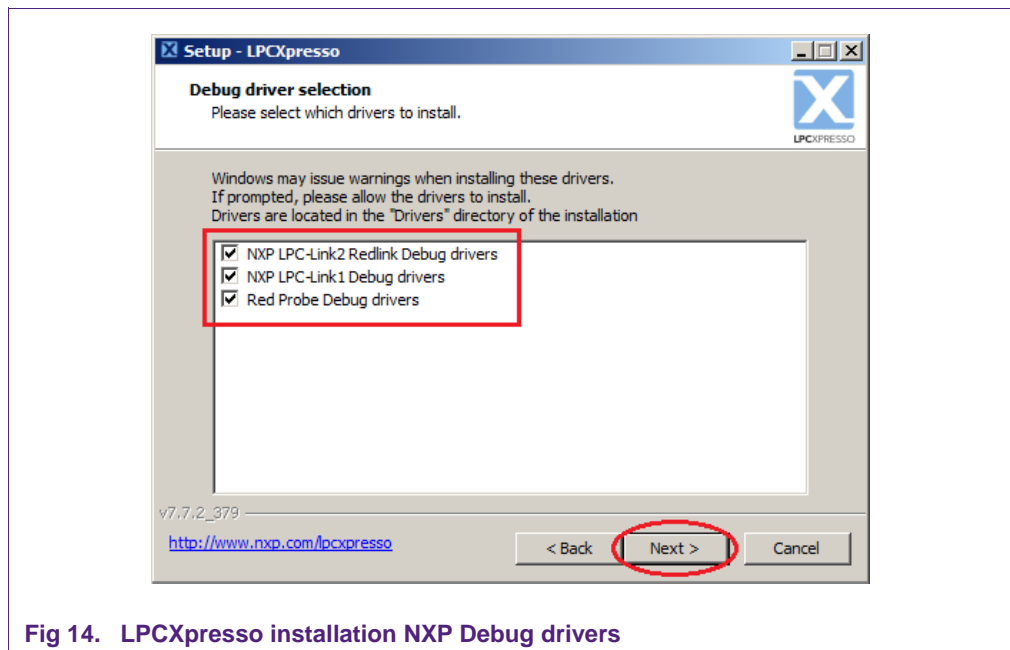

Fig 14. LPCXpresso installation NXP Debug drivers

Make sure, the checkboxes for installing the NXP Debug drivers are activated.

During the installation, the user will be asked if he wants to install some required drivers. The installation of these drivers should be accepted.

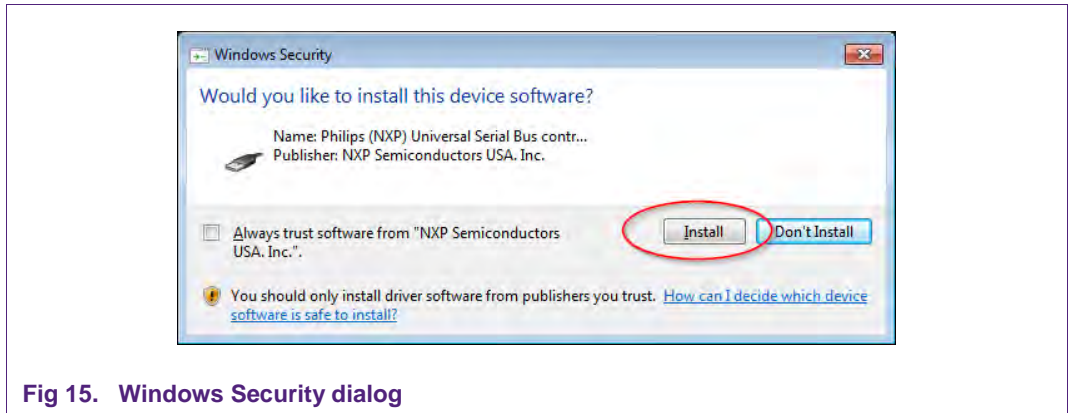

Fig 15. Windows Security dialog

After the setup wizard has finished one can launch the newly installed IDE.

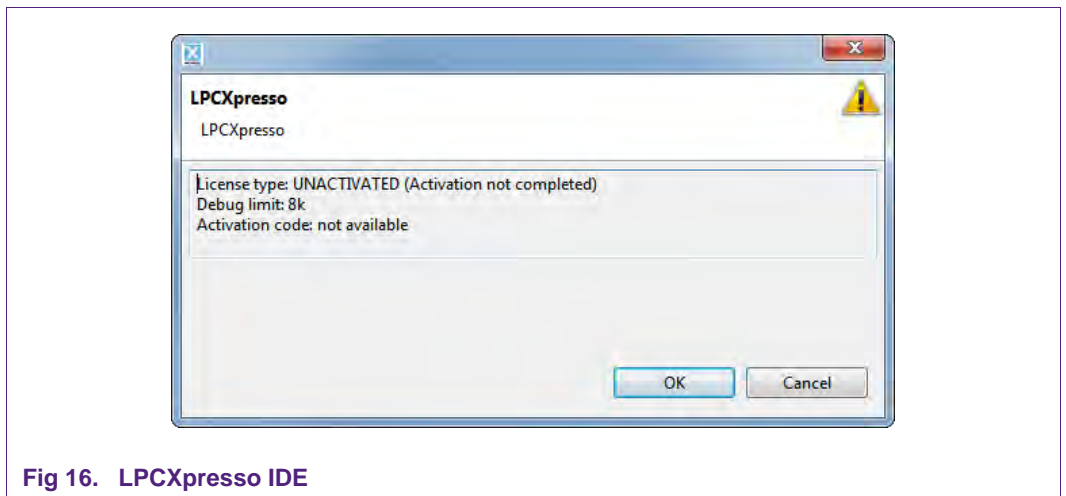

Fig 16. LPCXpresso IDE

Directly after the first start of the Eclipse IDE one will see an info dialogue that this is only an unregistered copy of LPCXpresso IDE. Just confirm the dialog and follow the instructions on the Welcome Screen to get a registered version without the debug limit of 8k. The registration is free and can be done at the LPCware website. The Link is shown in the menu, Help → Activate → Create Serial number and register...

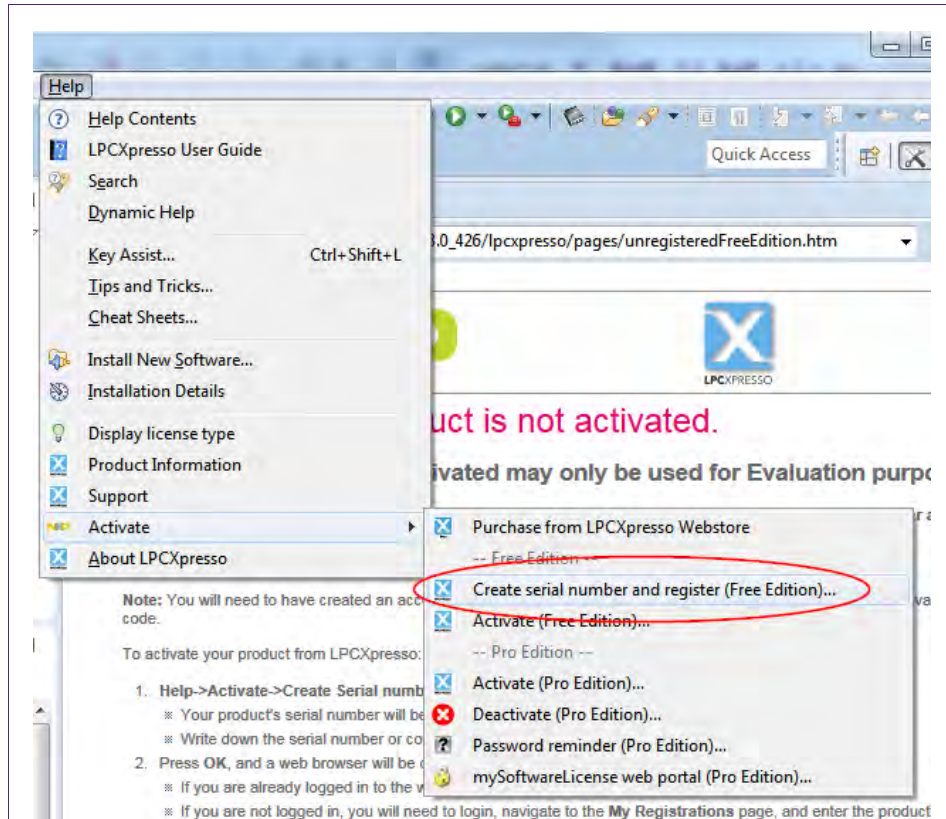

Fig 17. Product activation

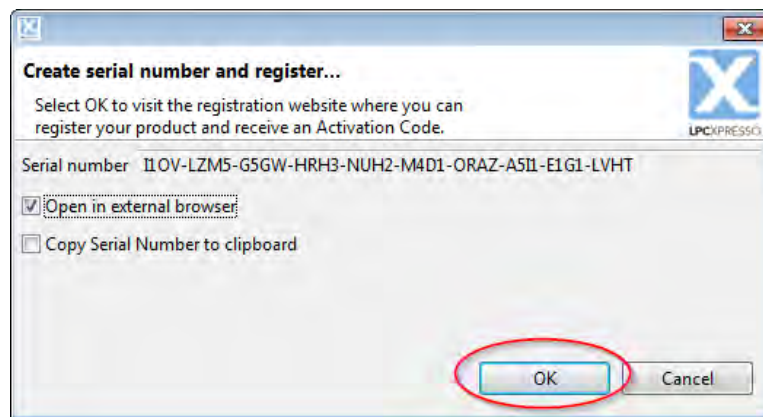

Fig 18. Product activation

If one doesn't already have an account at LPCware, please sign up to get an activation code. The code will be sent to the provided e-mail address.

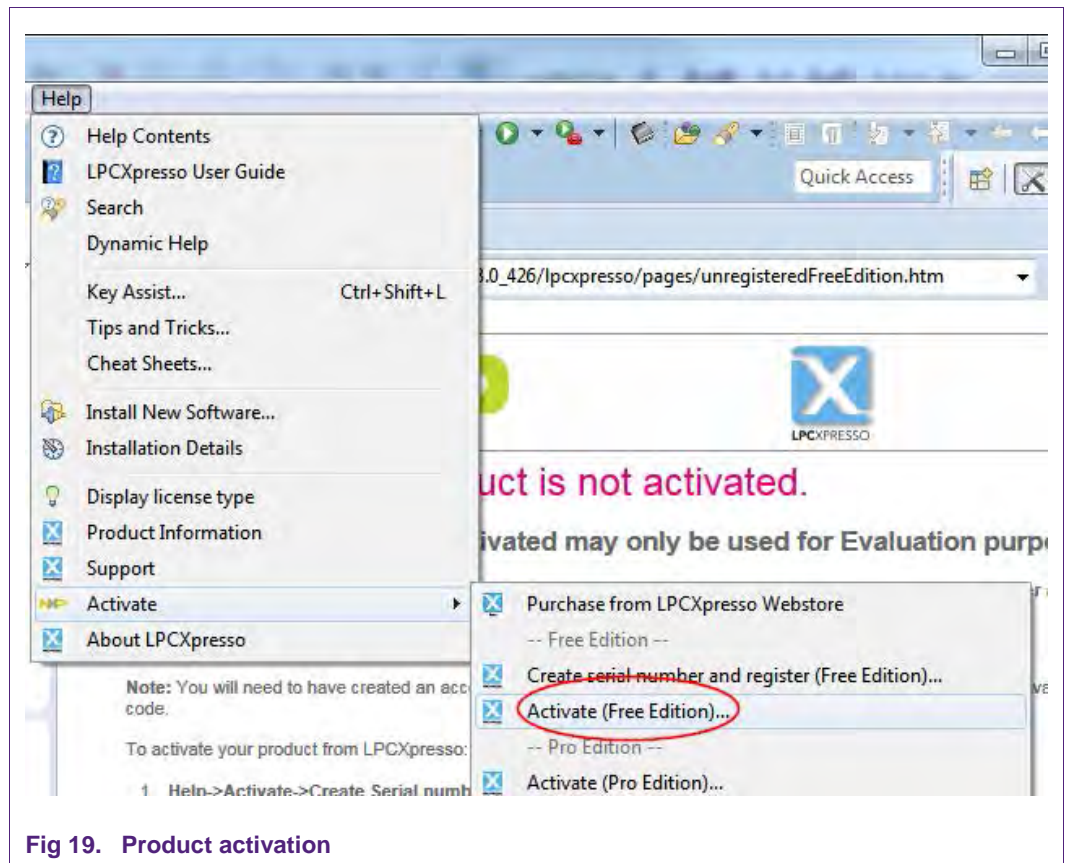

Fig 19. Product activation

Once the activation code arrives please open the activation window by pointing to Help → Activate → Activate (Free Edition), and enter the code. The success of the product activation will be confirmed by an info dialogue.

4.2 Extraction of the demo reader project

All demo reader projects are divided into three sub projects.

One project that contains the NFC Reader Library, one project that contains the FreeRTOS operating system, one project that contains all hardware dependent parts and one project that contains the example application.

All projects are distributed in one zip package that can be imported into the LPCXpresso IDE in one single action. The following example is based on this package.

The sequence of installing the reference reader projects is indicated:

- Start the LPCXpresso IDE.
- Select the option “Import project(s)” (see picture below).
- Browse the zip archive.
- LPCXpresso IDE unzips the software package.
- The software package is ready for use.

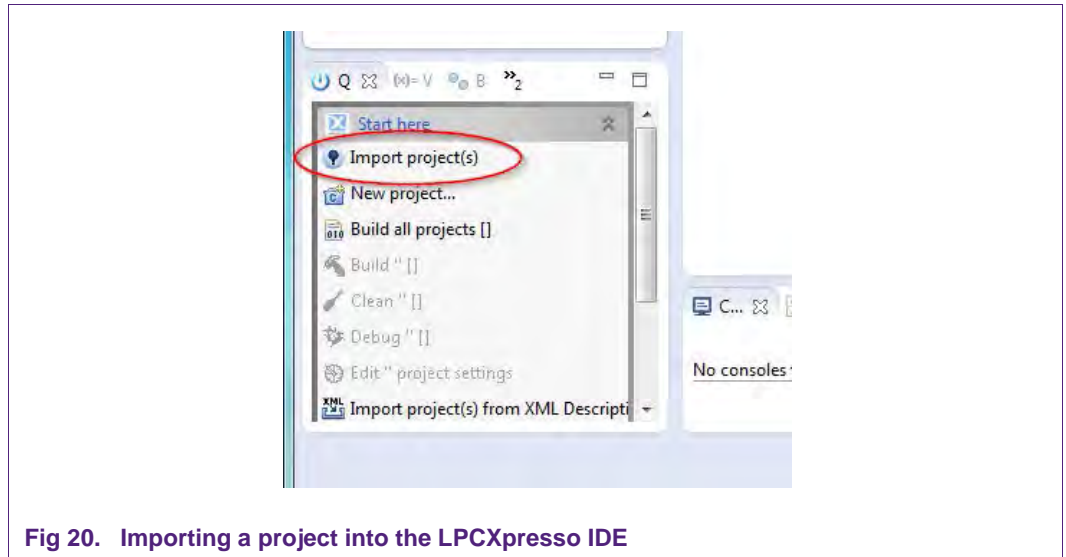

Fig 20. Importing a project into the LPCpresso IDE

In the Quick Panel on the left hand side, choose “Import projects(s)”.

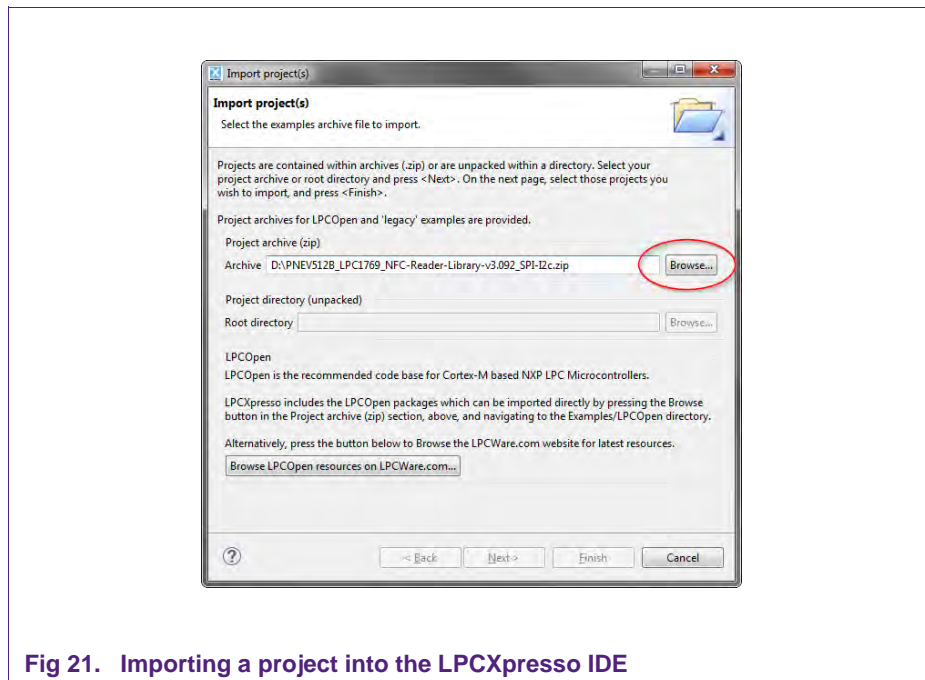

Fig 21. Importing a project into the LPCpresso IDE

Browse the desired package and click “Next”.

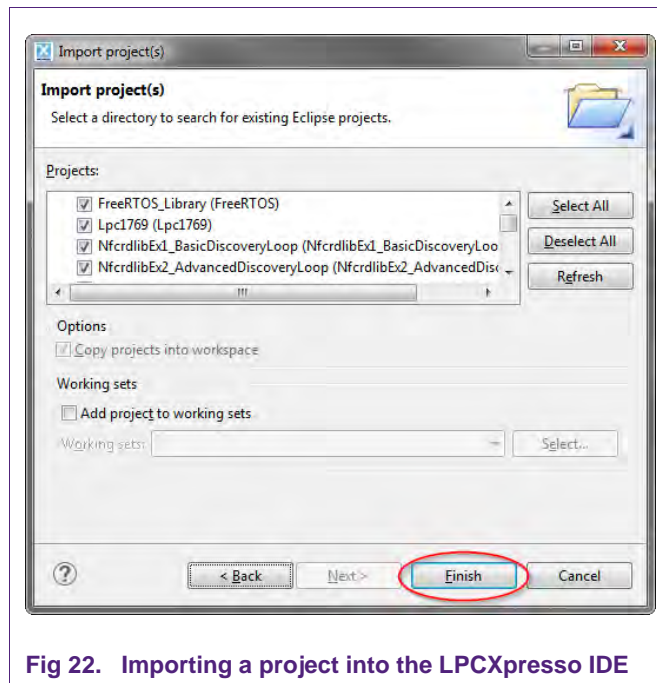

Fig 22. Importing a project into the LPCpresso IDE

For a working demo project you need to import at least four sub projects. One example project, the NFC Reader Library, FreeRTOS and one MCU project.

When the import process has finished one can start browsing the code.

Before one can run the project, the LPCpresso board containing the PN512 Blueboard needs to be connected to the computer. Wait until the adequate drivers have been installed.

4.3 Run the project

Before running the project, please ensure that the LPCpresso with the Blueboard is connected to the computer. Please also make sure that the correct microcontroller and the correct build configurations are chosen. Information about how to do this can be found in the sections 6.2 and 6.3.

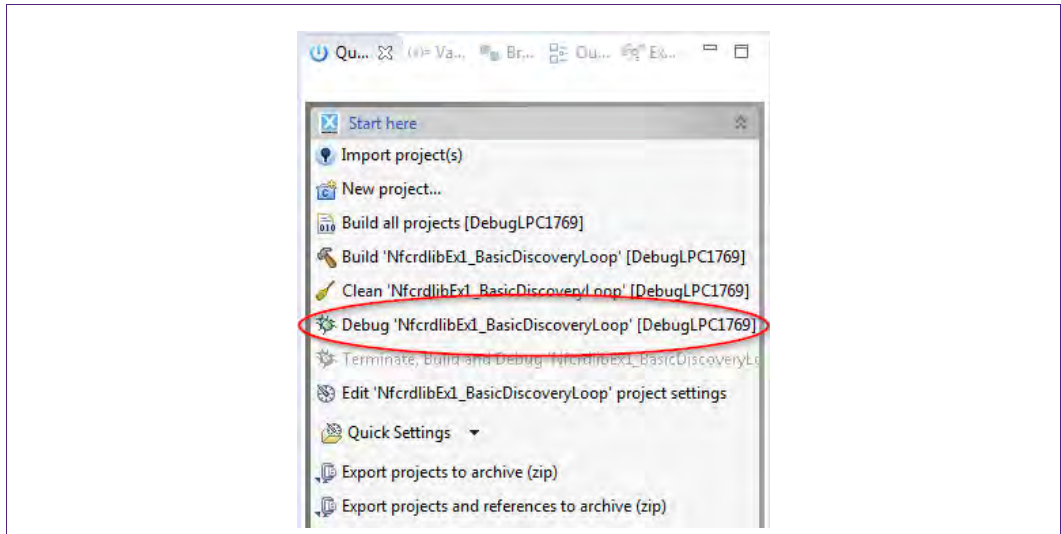

Fig 23. Run the project

Choose the project that contains the user application and click the Debug Button on the left hand side as shown in the example picture.

Make sure, the name of the build configuration as well as the selected MCU matches the name of the used microcontroller. See sections and 6.3 for further information.

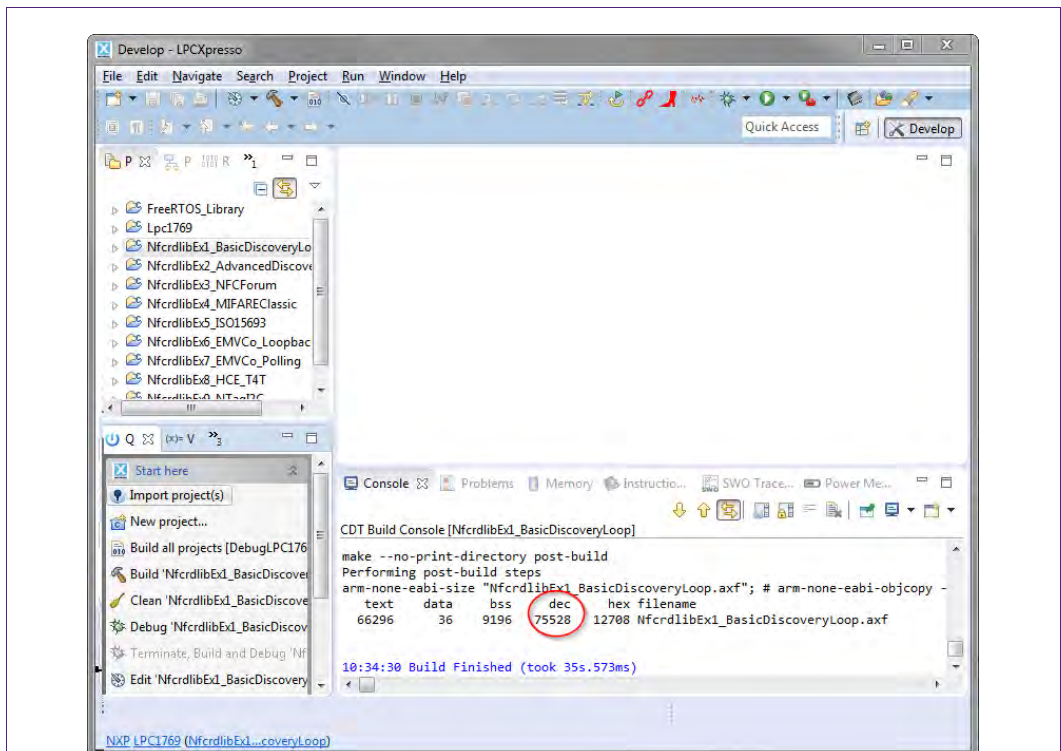

Fig 24. After the build process one can see the size of the image in the console window.

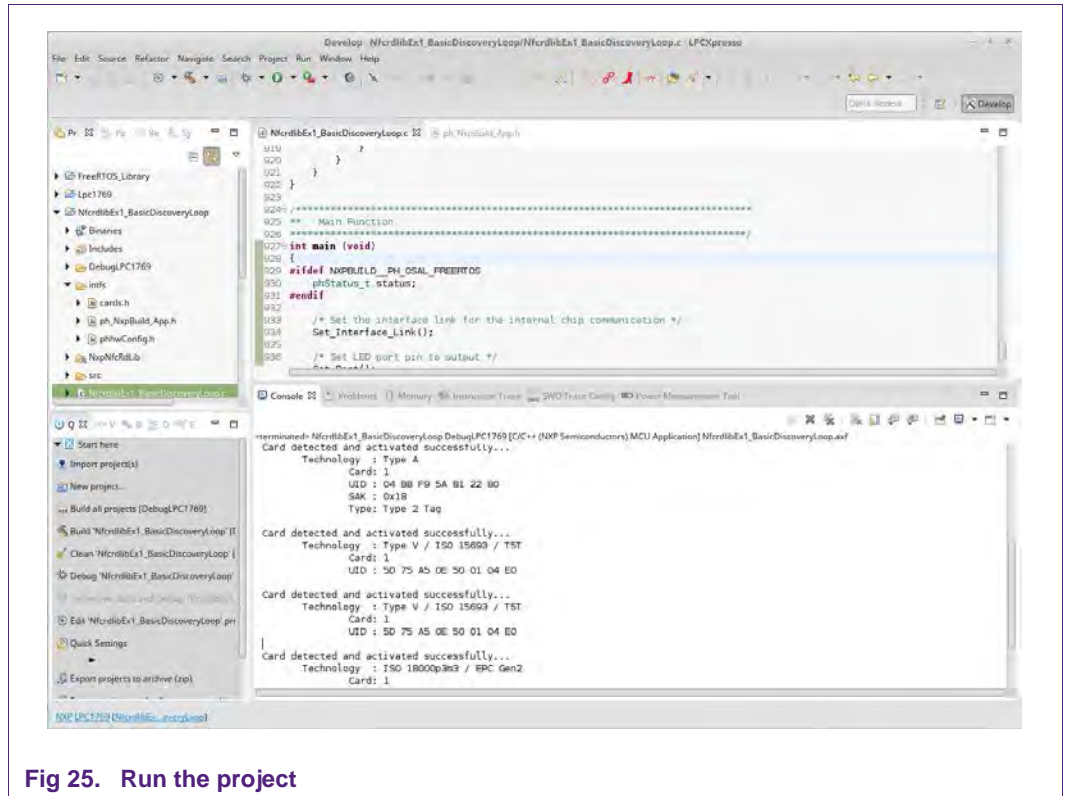

Fig 25. Run the project

After the software upload, the execution of the project starts immediately, but might halt at the initial breakpoint. To resume execution, just click onto the resume button.

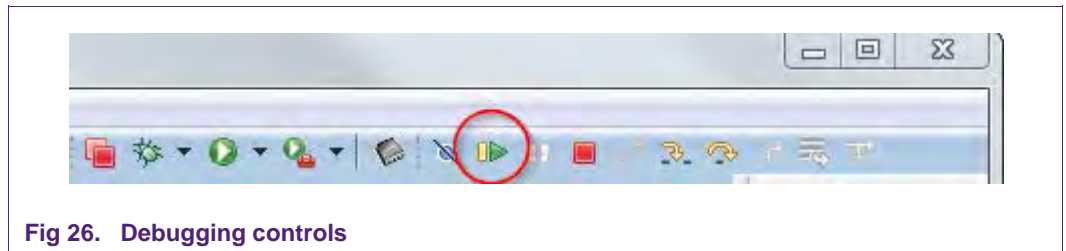

Fig 26. Debugging controls

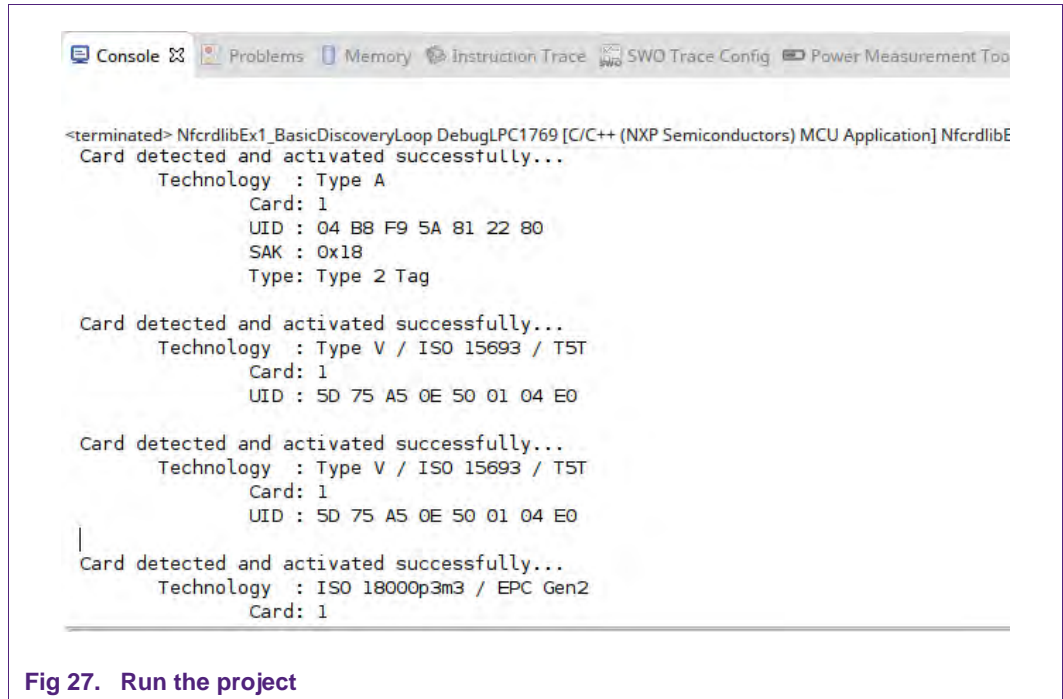

Fig 27. Run the project

In the console window at the bottom one will see the debug output of the execution.

After the execution has reached the end of the main function please click the Terminate button to stop the execution. Otherwise one won't be able to rerun the project. One can now do the following with the buttons near the top of the "Debug" view:

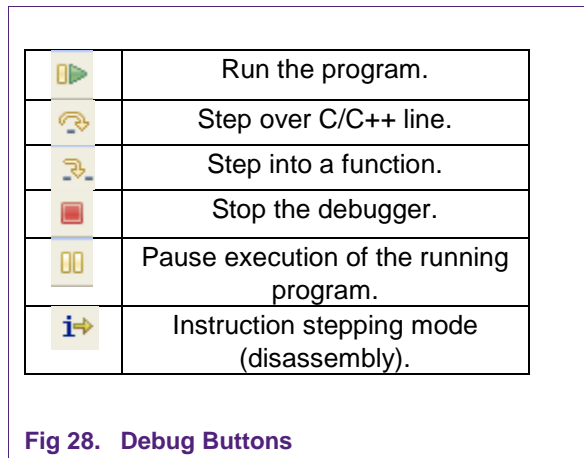

Fig 28. Debug Buttons

5. Associated Projects

All example projects are available for download at the product page of the PNEV512B [7] in the documents section and are being distributed in one single file.

All projects are packaged into a single installer file. After downloading the zip file please extract it and run the installer. The installer just copies all you need to get started to your hard disk.

5.1 Example 1 – Basic Discovery Loop

The Discovery Loop can be seen as the entry point when starting to communicate with an NFC tag or device. It scans the close environment for tags and devices of different technologies in range. In case something has been found, the Discovery Loop performs the anti-collision and identification. The obtained information are then passed back to the developer.

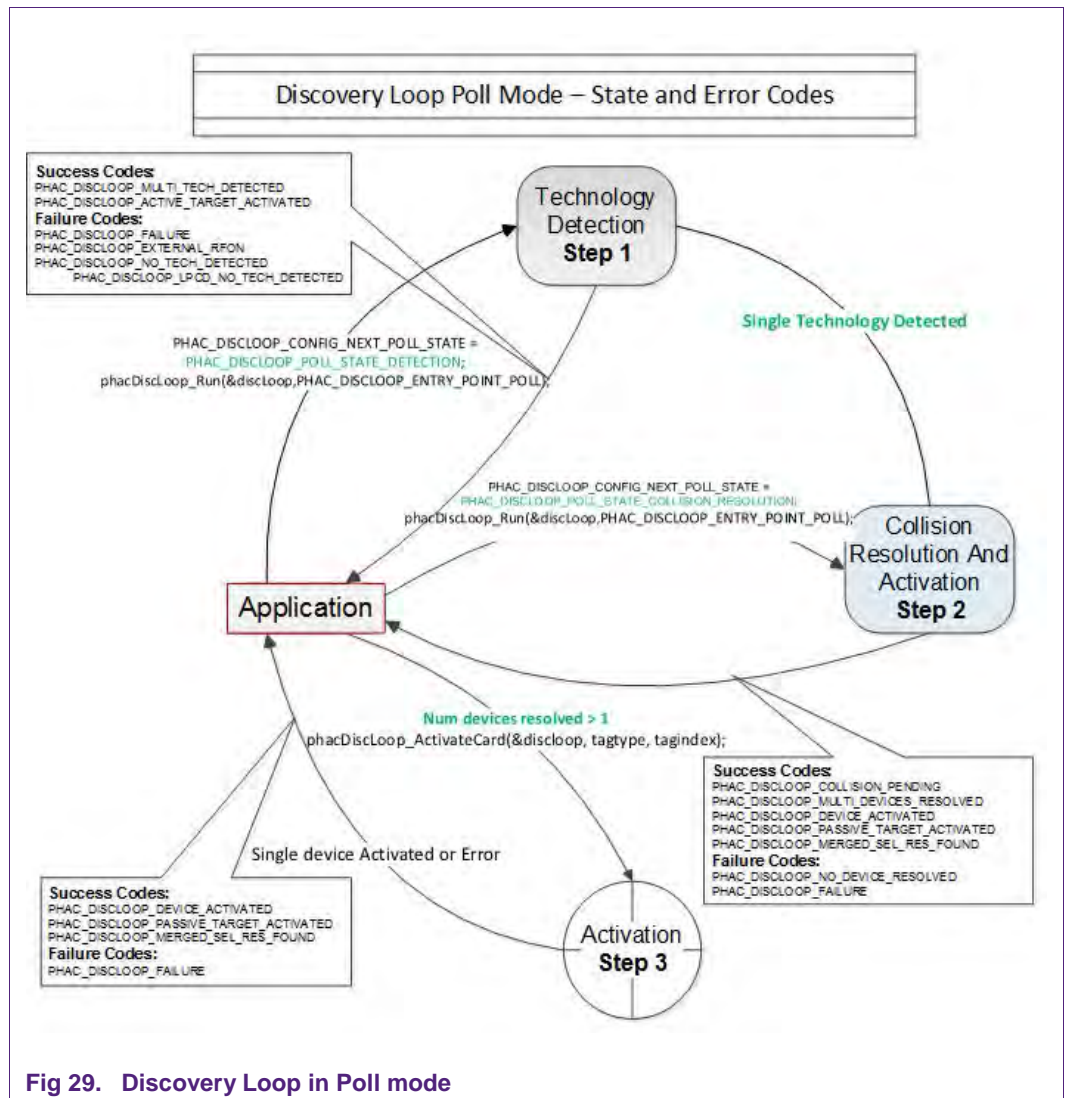

Fig 29. Discovery Loop in Poll mode

The example application first initializes the hardware, configures the host interface and continues execution in the function `BasicDiscoveryLoop_Demo()` in file `NfcrdlibEx1_BasicDiscoveryLoop.c`.

This function is the core of the example. It shows the initialization of the NFC Reader Library as well as the execution of the Discovery Loop. After the Discovery Loop has been executed, the user can see how to differently handle the detected tags or devices depending on the technology.

5.2 Example 2 – Advanced Discovery Loop

Additionally to Example 1 the Advanced Discovery Loop example explains the different configuration options of the Discovery Loop.

5.3 Example 3 – NFC Forum

Explains how to configure the NFC Reader Library for different P2P modes such as Active Mode, Target Mode, Initiator Mode and SNEP Client/Server. In SNEP Server mode the example waits for a connection from a SNEP Client. In case a SNEP Client transmits an NDEF message, the application displays it in the console window of the LPCXpresso IDE.

In SNEP Client mode, the application tries to connect to a SNEP Server. Once the connection is established, it transmits an NDEF message to the server.

5.4 Example 4 – MIFARE Classic

Basic read/write operations on MIFARE Classic cards are demonstrated with this example. It shows the developer the most important operations to get started with these cards.

5.5 Example 6 – EMVCo Loopback

The EMVCo Loopback application is provided together with the NFC Reader Library to help the customer reaching EMVCo Level 1 certification for his device. The example itself produces no output in the console window of the LPCXpresso IDE.

5.6 Example 7 – EMVCo Polling

The EMVCo Polling example demonstrates how to configure the NFC Reader Library as specified by EMVCo specification and starts polling for EMVCo cards. Once an EMVCo compatible card is found, it demonstrates the exchange of APDU commands. This example shall help the developer getting started more quickly when working with EMVCo cards.

5.7 Example 8 – HCE T4T

Example 8 implements a Type 4 Tag card emulation according to NFC Forum Type 4 Tag specification. The example supports all specified commands such as Select, ReadBinary, UpdateBinary.

5.8 Example 9 – NTAG-I2C

The NTAG-I2C example demonstrates the use of special features which are needed to work with the NTAG-I2C. For more details about the NTAG-I2C and its functionalities please consult the product page of the same [13].

6. Supplementary Notes

For detailed API description of the NFC Reader Library please refer to the chm help file located at `NFC_Reader_Library\docs\14_user_doc\NXP NFC Reader Library.chm`.

6.1 General Software Architecture

The software of the reference reader is based on the NFC Reader Library [5]. It intends to be simple, modular, easily readable and quickly portable by all the customers. This philosophy is reflected in its architecture which is divided into 4 layers:

- BAL (Bus Abstraction Layer),
- HAL (Hardware Abstraction Layer)
- PAL (Protocol Abstraction Layer)
- AL (Abstraction Layer)

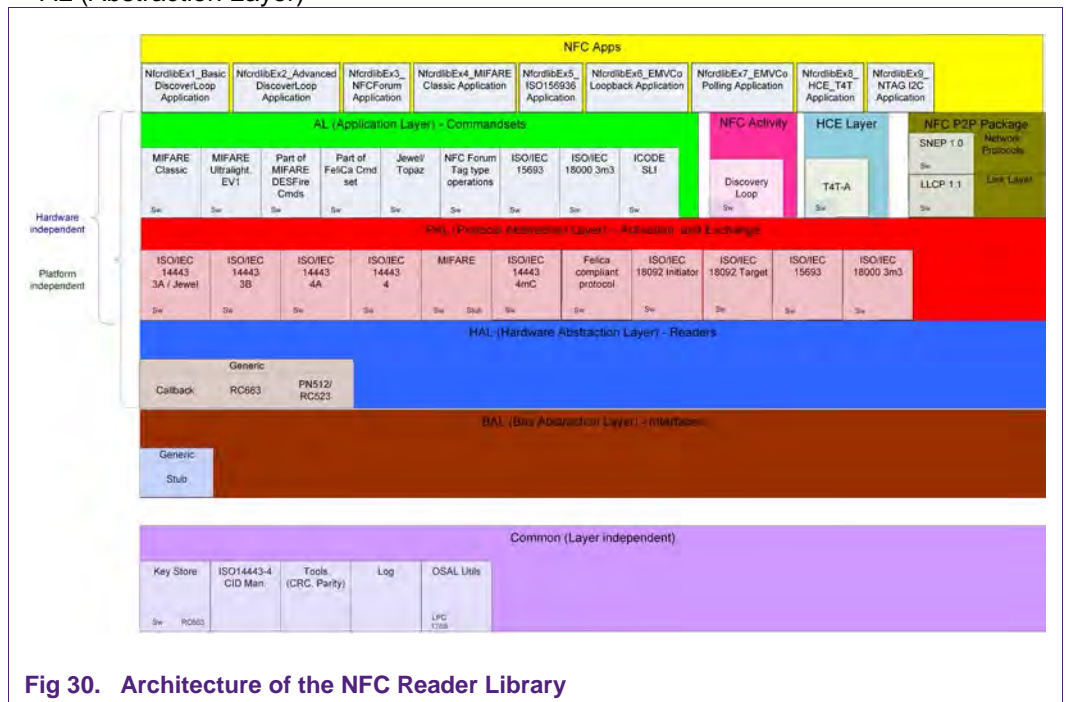

Fig 30. Architecture of the NFC Reader Library

For a detailed description of the NFC Reader Library please refer to the user manual **UM10721 - NXP NFC Reader Library User Manual**.

Documentation of the API can be found in the document **UM10802 - NXP NFC Reader Library API**. Both can be downloaded at the web site of the PNEV512B demo board [7].

6.1.1 Bus abstraction layer

This layer offers functions to abstract the hardware parts of the microcontroller.

These functions connect to the specific peripheral drivers of the microcontroller. Based on these stacks, the communication routines for the relevant physical media I2C/SPI can be easily designed. These drivers used in this examples are specific for the LPC1XXX

family and therefore cannot be ported to other microcontrollers. If one want's to change the microcontroller, he would have to adapt this layer.

6.1.2 Hardware abstraction layer

This layer offers functions to abstract the hardware parts of the supported transceivers.

6.1.3 Protocol abstraction layer

Every PAL function is a low level function realizing a single functionality. It is encapsulated in a module which is independent from the others. The user can easily design his application by doing a drag-and-drop of the relevant module.

The following PAL modules are available in this software package:

- ISO/IEC 14443-3A,
- ISO/IEC 14443-3B,
- ISO/IEC 14443-4,
- MIFARE,
- ISO/IEC 14443-4mC
- FeliCa,
- NFC Initiator
- NFC Target
- ISO/IEC 15693
- ISO/IEC 18000-3 Mode 3

6.1.4 Application layer

Lying on the previous software layers, the application layer is on top of the reader software package. It combines elements of the previous three parts into high level functionalities.

6.1.5 NFC Activity

This component provides the Discovery Loop component. It implements poll mode based on NFC Activity Specification 1.1 (backward compatibility with version 1.0) and EMVCo Specification 2.3.1a. Listen mode is implemented based on NFC Activity Specification 1.1. Support for Type V (ISO 15693) polling is included based on NFC Forum draft specification. ISO 18000-3 Mode 3 (EPC Gen2) is supported as a proprietary technology in poll mode.

6.1.6 HCE Layer

This component implements the card emulation of NFC Forum Type 4A Tag.

The implementation is based on NFC Forum Type 4 Tag Operation Specification version 2.0. SELECT, READ BINARY and UPDATE BINARY commands are supported as per NFC Forum Type 4 Tag Operation Specification.

This layer follows a multi-threaded RTOS based design using one reader library thread and one application thread. Application thread along with application callback can be used for handling of UPDATE BINARY and proprietary commands.

A pictorial representation of reader library thread and application thread used for card emulation is shown below. Refer function documentation for more information.

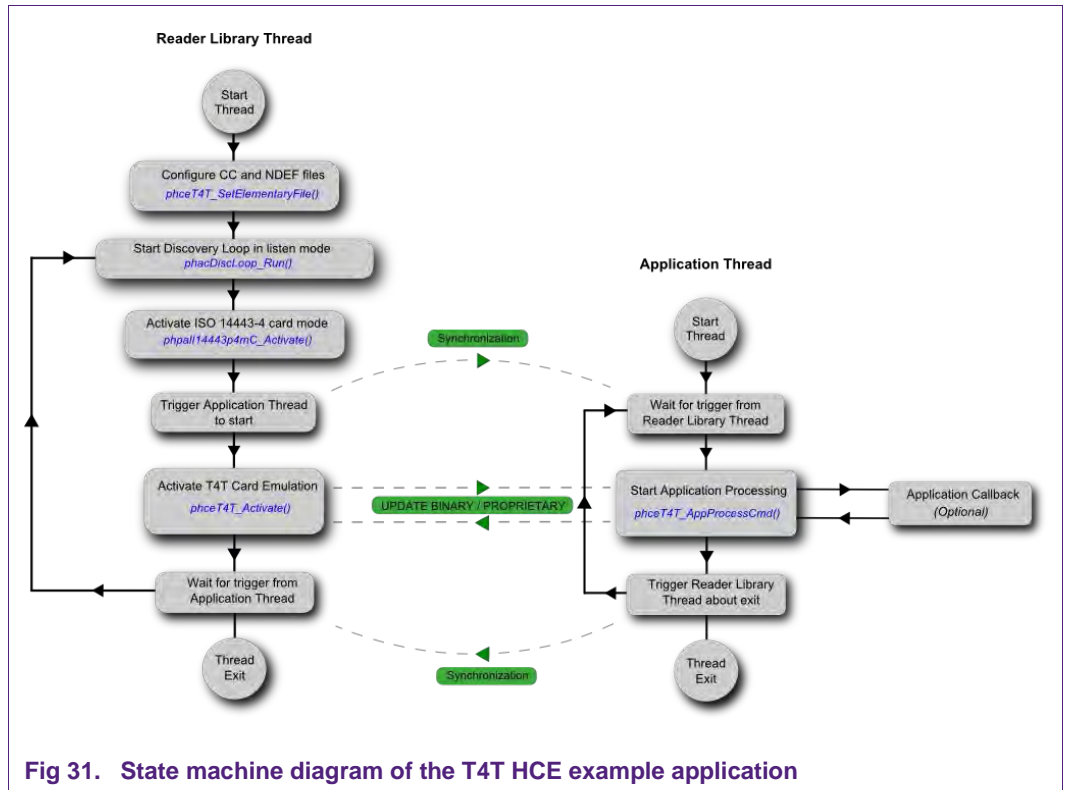

Fig 31. State machine diagram of the T4T HCE example application

As UPDATE BINARY and proprietary commands are handled by the `phceT4T_AppProcessCmd` in application thread, application shall use some synchronization mechanism (like mutex or semaphore) as shown in the diagram to synchronize entry to and exit from `phceT4T_Activate` and `phceT4T_AppProcessCmd`.

Waiting Time eXtension (WTX) is handled internally by `phceT4T_Activate` in reader library thread. The reader library thread should be of high priority than the application thread for proper handling of WTX. In non RTOS single threaded environment this layer can be used with limited features, i.e. with no support for WTX.

6.1.7 NFC Apps

The example applications make use of the underlying functions. They provide entry points for the developers to get started with the NFC Reader Library more quickly.

6.2 Build configuration

All the projects mentioned in this guide are available in debug and release configuration.

- Debug configuration
 - This configuration is mainly used when the target board is attached to the PC with the JTAG debugger. It allows the display of debug messages in the console window, which is useful in the early stage of the project.
- Release configuration

Once the project is debugged and mature, it might be interesting to use the release configuration, to use the hardware stand alone. No debug messages are displayed in the console window.

Note, that only in Release Configuration one can flash the software onto the Blueboard and start it automatically, once power has been attached to the board.

The build configuration can be selected as follows:

- Click on the project in the project window of the LPCXpresso IDE,
- Right click of the mouse → Select Build Configuration,
- Set active DebugLPC1769 build (or ReleaseLPC1769 build) for LPC 1769.

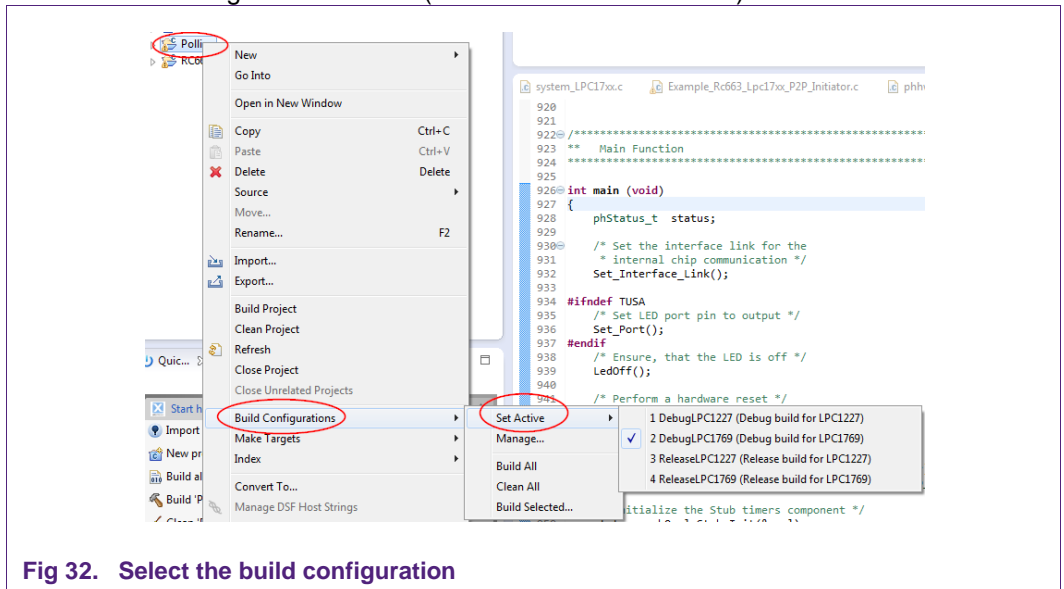

Fig 32. Select the build configuration

Note: When switching from one MCU to another, please take care to also switch to the correct MCU setting within the LPCXpresso IDE. See section 6.3.

6.3 Setting the MCU

There are many LPC microcontrollers supported by the LPCXpresso IDE build in compiler. Before compiling a project, the correct MCU need to be set.

- Right click the project → choose properties (at the bottom)
- C/C++ build → MCU settings → expand desired LPC1xxx MCU group → choose the correct microcontroller → click OK

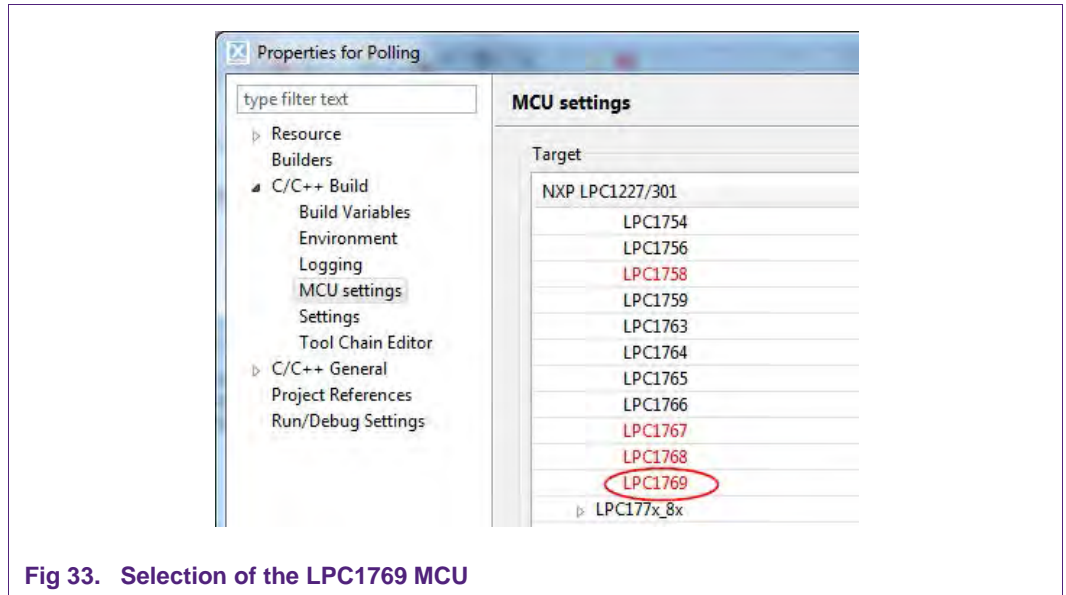

Fig 33. Selection of the LPC1769 MCU

6.4 Level of compiler optimization

When the code size at the current compiler level overloads the FLASH size of the target board, a higher compiler optimization level can be selected to reduce the code size of the project.

The following steps can be followed to select a level of compiler optimization:

- Click on the application project in the project window of the LPCXpresso IDE,
- Right click of the mouse → Select properties → Select C/C++ build,
- Select Settings → Optimization,
- Choose the desired level in the combo box.

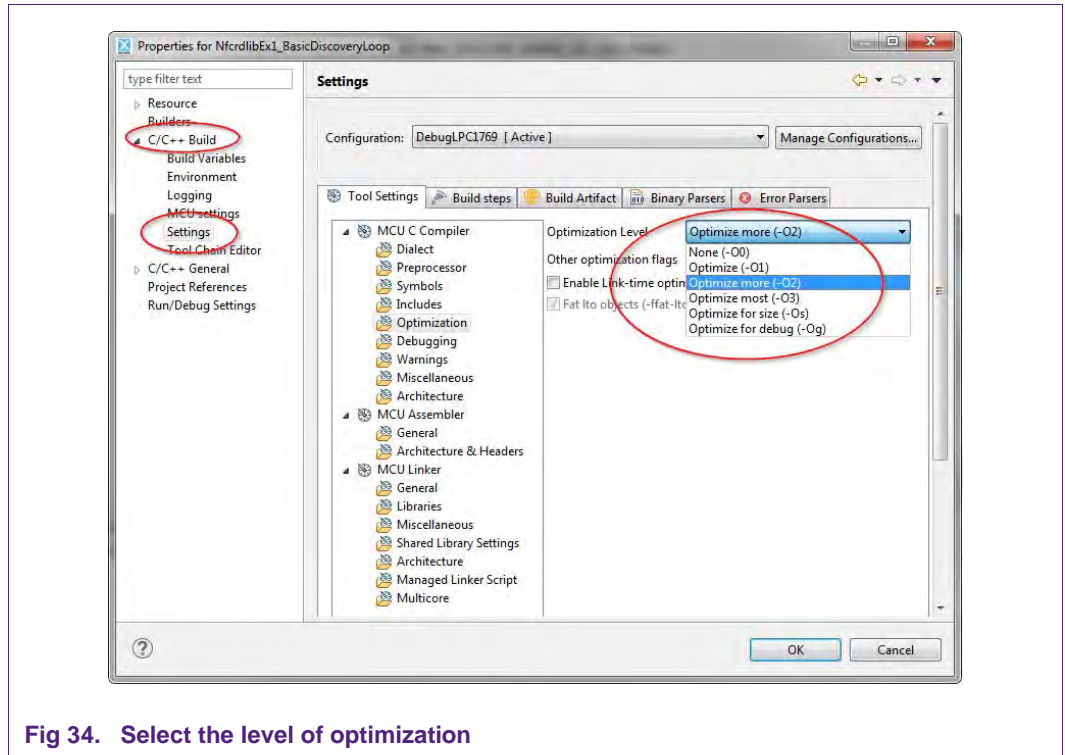

Fig 34. Select the level of optimization

6.4.1 Optimization issues

When optimization is enabled, it will reorder code. What this means is that the code from multiple C lines will be intermingled. In addition, assignments and initializations might be pulled out of loops so they are only executed once. Changes like these will make the code confusing to debug. Some symptoms one might see are breakpoints that only work the first time through, or seeing the debugger's current line indicator fail to advance or even move backwards when clicking step. It is best to always use -O0 for debugging.

6.5 Preparing the projects for the use of the Blueboard in I²C configuration

To use the projects in I²C configuration one has to do some small adaptations in the file phhwConfig.h located in the MCU project LPC1xxx.

1. Open the file ../LPC1769/phLpc1768_Build.h and
 - a. Uncomment the line `#define I2C_USED.`
 - b. Comment the line `#define SPI_USED.`

6.6 Removing the initial breakpoint on debug startup

When the debugger starts, it automatically sets a breakpoint at the first statement in the main() function. One can remove this breakpoint as follows:

1. Right click on the project and choose Launch Configurations → Edit current...

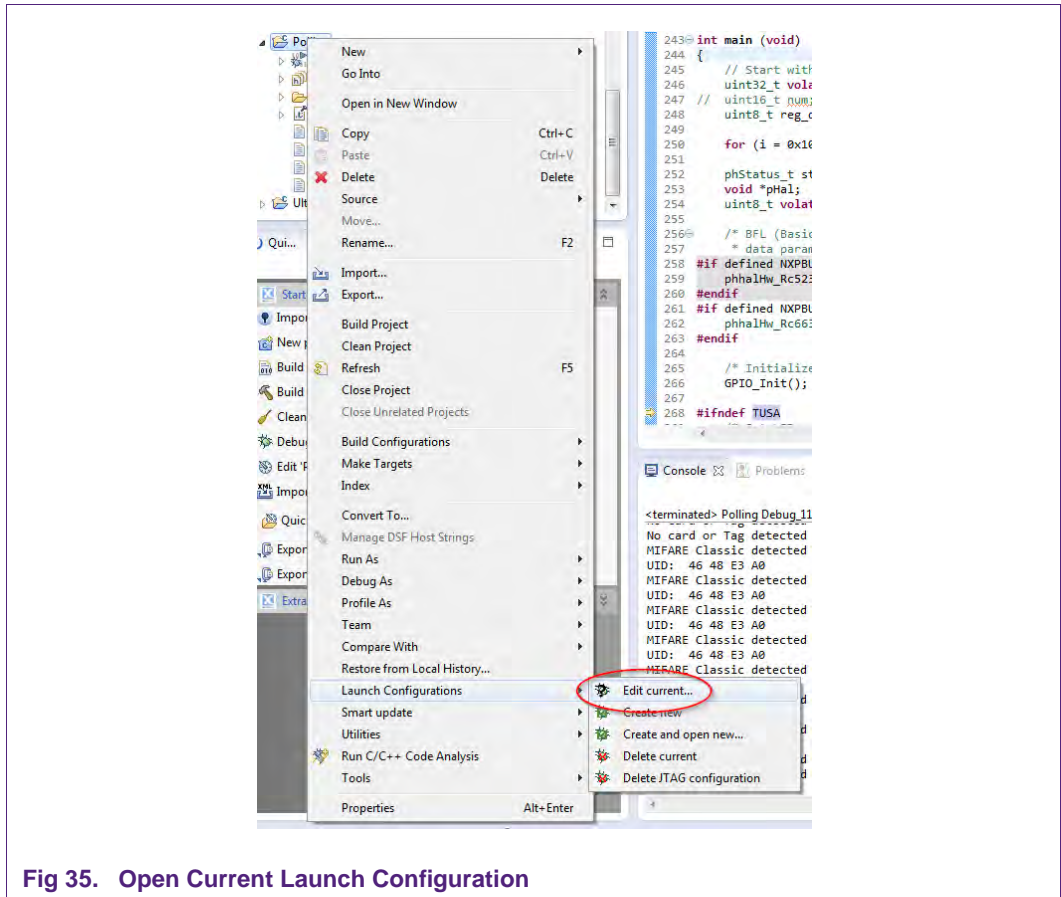
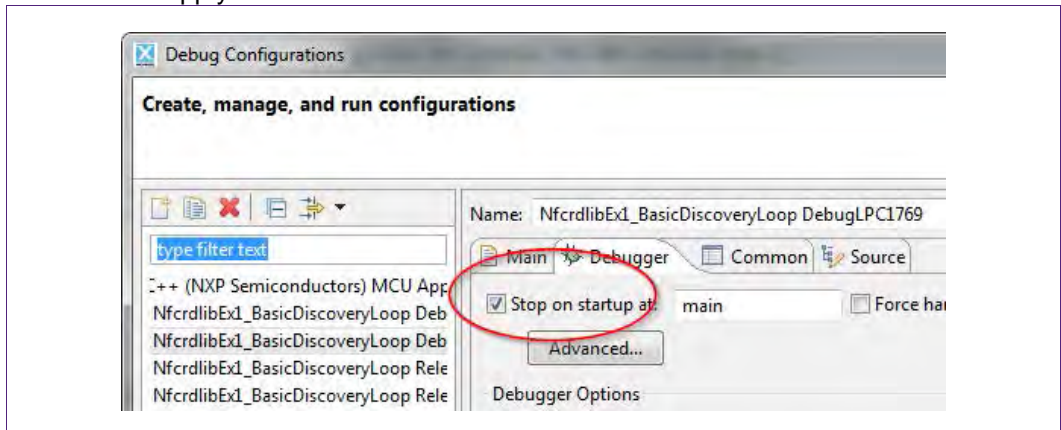

Fig 35. Open Current Launch Configuration

1. Choose the Debug configuration
2. Choose the tab Debugger
3. Uncheck the box near “Stop on startup at:”
4. Click onto Apply and then Close.



6.7 Using the Blueboard with the Raspberry Pi

Detailed instructions about how to run the NFC Reader Library on the Raspberry Pi can be found in the Start Guide linked at the product page of the EXPLORE-NFC [\[12\]](#). This sub chapter only describes some information that is not included in the start guide of the EXPLORE-NFC.

6.7.1 Preparing the hardware

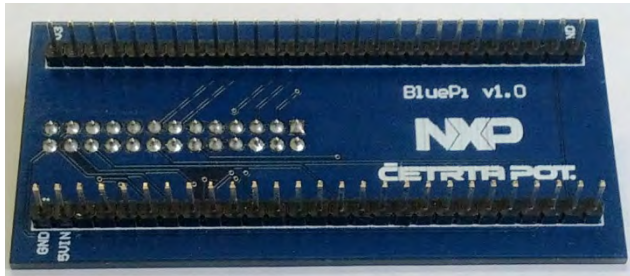

a. Connector for the Blueboard

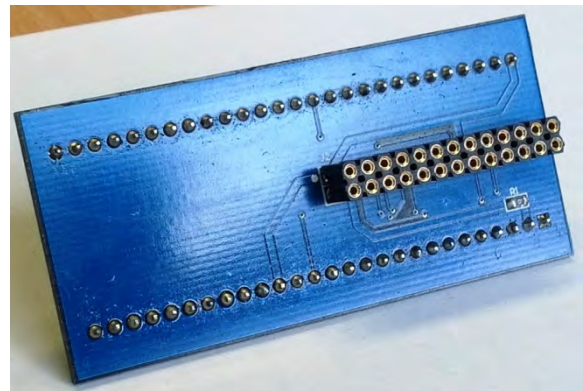

b. Connector for the Raspberry Pi

Fig 36. BluePi adaptor

- Connect the PNEV512B Blueboard to the BluePi adaptor.
- Connect the adaptor to the Raspberry Pi

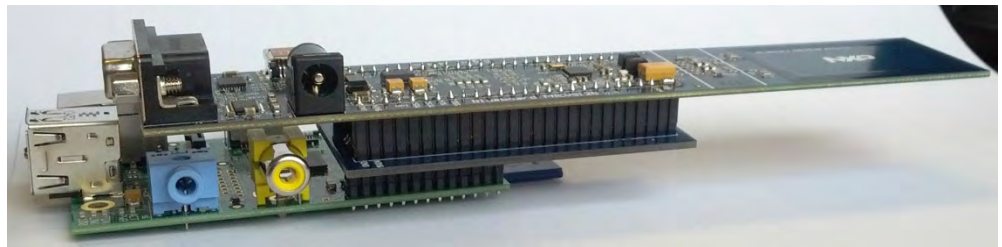

Fig 37. PNEV512B Blueboard connected to the Raspberry Pi

7. References

- [1] **LPCXpresso website**
<http://www.lpcware.com/lpcxpresso/download>
- [2] **PN512 product information and data sheet**
http://www.nxp.com/products/interface_and_connectivity/nfc_contactless_reader_ics/series/PN512.html
- [3] **LPC176x/5x User manual**
http://www.nxp.com/documents/user_manual/UM10360.pdf
- [4] **Multipoint Connectors we used:**
Grid Dimension: 2.54mm, at least 27 pins
<http://www.conrad.at/ce/de/product/741119/STIFTLEISTE>
and
<http://www.conrad.at/ce/de/product/736427/BUCHSENLEISTE-EINREIHIG>
- [5] **Direct link to the NFC Reader Library**
Not yet available
- [6] **TYPE 4 TAG: NFC Forum, Type 4 Tag Operation Specification, Version 2.0, March 13, 2007**
<http://www.nfc-forum.org/specs>
- [7] **PNEV512B demo board site**
<http://www.nxp.com/demoboard/PNEV512B.html>
- [8] **NXP NFC Reader Library User Manual**
http://www.nxp.com/documents/user_manual/UM10721.pdf
- [9] **Technical Specification** – Simple NDEF Exchange Protocol, NFCForum-TS-SNEP_1.0
http://www.nfc-forum.org/specs/spec_license
- [10] **EMV** – The table of card types and their matching AIDs are available on
<http://www.en.wikipedia.org/wiki/EMV>
- [11] **LPCXpresso LPC1769 development board**
<http://www.nxp.com/demoboard/OM13000.html>
- [12] **EXPLORE-NFC product page**
<http://www.nxp.com/demoboard/PNEV512R.html#documentation>
- [13] **NTAG-I2C**
http://www.nxp.com/products/identification_and_security/nfc_and_reader_ics/connected_tag_solutions/series/NT3H1101_NT3H1201.html

8. Legal information

8.1 Definitions

Draft — The document is a draft version only. The content is still under internal review and subject to formal approval, which may result in modifications or additions. NXP Semiconductors does not give any representations or warranties as to the accuracy or completeness of information included herein and shall have no liability for the consequences of use of such information.

8.2 Disclaimers

Limited warranty and liability — Information in this document is believed to be accurate and reliable. However, NXP Semiconductors does not give any representations or warranties, expressed or implied, as to the accuracy or completeness of such information and shall have no liability for the consequences of use of such information.

In no event shall NXP Semiconductors be liable for any indirect, incidental, punitive, special or consequential damages (including - without limitation - lost profits, lost savings, business interruption, costs related to the removal or replacement of any products or rework charges) whether or not such damages are based on tort (including negligence), warranty, breach of contract or any other legal theory.

Notwithstanding any damages that customer might incur for any reason whatsoever, NXP Semiconductors' aggregate and cumulative liability towards customer for the products described herein shall be limited in accordance with the Terms and conditions of commercial sale of NXP Semiconductors.

Right to make changes — NXP Semiconductors reserves the right to make changes to information published in this document, including without limitation specifications and product descriptions, at any time and without notice. This document supersedes and replaces all information supplied prior to the publication hereof.

Suitability for use — NXP Semiconductors products are not designed, authorized or warranted to be suitable for use in life support, life-critical or safety-critical systems or equipment, nor in applications where failure or malfunction of an NXP Semiconductors product can reasonably be expected to result in personal injury, death or severe property or environmental damage. NXP Semiconductors accepts no liability for inclusion and/or use of NXP Semiconductors products in such equipment or applications and therefore such inclusion and/or use is at the customer's own risk.

Applications — Applications that are described herein for any of these products are for illustrative purposes only. NXP Semiconductors makes no representation or warranty that such applications will be suitable for the specified use without further testing or modification.

Customers are responsible for the design and operation of their applications and products using NXP Semiconductors products, and NXP Semiconductors accepts no liability for any assistance with applications or customer product design. It is customer's sole responsibility to determine whether the NXP Semiconductors product is suitable and fit for the customer's applications and products planned, as well as for the planned application and use of customer's third party customer(s). Customers should provide appropriate design and operating safeguards to minimize the risks associated with their applications and products.

NXP Semiconductors does not accept any liability related to any default, damage, costs or problem which is based on any weakness or default in the customer's applications or products, or the application or use by customer's

third party customer(s). Customer is responsible for doing all necessary testing for the customer's applications and products using NXP Semiconductors products in order to avoid a default of the applications and the products or of the application or use by customer's third party customer(s). NXP does not accept any liability in this respect.

Export control — This document as well as the item(s) described herein may be subject to export control regulations. Export might require a prior authorization from competent authorities.

Evaluation products — This product is provided on an "as is" and "with all faults" basis for evaluation purposes only. NXP Semiconductors, its affiliates and their suppliers expressly disclaim all warranties, whether express, implied or statutory, including but not limited to the implied warranties of non-infringement, merchantability and fitness for a particular purpose. The entire risk as to the quality, or arising out of the use or performance, of this product remains with customer.

In no event shall NXP Semiconductors, its affiliates or their suppliers be liable to customer for any special, indirect, consequential, punitive or incidental damages (including without limitation damages for loss of business, business interruption, loss of use, loss of data or information, and the like) arising out of the use of or inability to use the product, whether or not based on tort (including negligence), strict liability, breach of contract, breach of warranty or any other theory, even if advised of the possibility of such damages.

Notwithstanding any damages that customer might incur for any reason whatsoever (including without limitation, all damages referenced above and all direct or general damages), the entire liability of NXP Semiconductors, its affiliates and their suppliers and customer's exclusive remedy for all of the foregoing shall be limited to actual damages incurred by customer based on reasonable reliance up to the greater of the amount actually paid by customer for the product or five dollars (US\$5.00). The foregoing limitations, exclusions and disclaimers shall apply to the maximum extent permitted by applicable law, even if any remedy fails of its essential purpose.

8.3 Licenses

Purchase of NXP ICs with ISO/IEC 14443 type B functionality



This NXP Semiconductors IC is ISO/IEC 14443 Type B software enabled and is licensed under Innovatron's Contactless Card patents license for ISO/IEC 14443 B.

The license includes the right to use the IC in systems and/or end-user equipment.

RATP/Innovatron
Technology

8.4 Trademarks

Notice: All referenced brands, product names, service names and trademarks are property of their respective owners.

MIFARE — is a trademark of NXP Semiconductors N.V.

DESFire — is a trademark of NXP Semiconductors N.V.

MIFARE Ultralight — is a trademark of NXP Semiconductors N.V.

MIFARE Plus — is a trademark of NXP Semiconductors N.V.

9. List of tables

Table 1.	Example projects	3	Table 4.	Solder Jumpers for USB connector configuration.....	10
Table 2.	A0 and A1 interface configuration	8	Table 5.	VCC power supply configuration	10
Table 3.	Solder Jumpers for selecting the additional interfaces	9			

10. List of figures

Fig 1.	Picture of PNEV512B demo board.....	4	Fig 19.	Product activation.....	15
Fig 2.	Picture of solder bridges in default configuration	5	Fig 20.	Importing a project into the LPCXpresso IDE..	16
Fig 3.	Picture of LPCXpresso LPC1769 development board.....	5	Fig 21.	Importing a project into the LPCXpresso IDE..	16
Fig 4.	Multipoint Connectors we used	6	Fig 22.	Importing a project into the LPCXpresso IDE..	17
Fig 5.	LPCXpresso with the Multipoint Connectors	6	Fig 23.	Run the project.....	18
Fig 6.	Connect the two boards	6	Fig 24.	After the build process one can see the size of the image in the console window.	18
Fig 7.	Interrupt connection	7	Fig 25.	Run the project.....	19
Fig 8.	Interesting points of measurement.....	7	Fig 26.	Debugging controls	19
Fig 9.	Blueboard in SPI configuration.....	8	Fig 27.	Run the project.....	20
Fig 10.	Additional interfaces.....	9	Fig 28.	Debug Buttons	20
Fig 11.	Solder jumpers for additional interface configuration	9	Fig 29.	Discovery Loop in Poll mode.....	21
Fig 12.	Solder jumper for VCC power supply configuration	10	Fig 30.	Architecture of the NFC Reader Library	24
Fig 13.	Enumeration of the LPCXpresso Board in Device Manager Window	11	Fig 31.	State machine diagram of the T4T HCE example application	26
Fig 14.	LPCXpresso installation NXP Debug drivers ..	12	Fig 32.	Select the build configuration	27
Fig 15.	Windows Security dialog.....	13	Fig 33.	Selection of the LPC1769 MCU	28
Fig 16.	LPCXpresso IDE.....	13	Fig 34.	Select the level of optimization.....	29
Fig 17.	Product activation	14	Fig 35.	Open Current Launch Configuration	30
Fig 18.	Product activation	14	Fig 36.	BluePi adaptor.....	31
			Fig 37.	PNEV512B Blueboard connected to the Raspberry Pi	31

11. Contents

1.	Introduction	3	6.1.5	NFC Activity.....	25
2.	Hardware overview of the Demo Reader.....	4	6.1.6	HCE Layer.....	25
2.1	PNEV512B demo board.....	4	6.1.7	NFC Apps.....	26
2.2	CE certification of the Blueboard.....	5	6.2	Build configuration.....	26
2.3	LPCXpresso LPC1769 development board	5	6.3	Setting the MCU	27
2.4	Preparation of the hardware.....	6	6.4	Level of compiler optimization	28
2.5	Soldering the interrupt connection.....	7	6.4.1	Optimization issues	29
2.6	Interesting points of measurement.....	7	6.5	Preparing the projects for the use of the Blueboard in I ² C configuration	29
2.7	Preparing the Blueboard for the use with SPI or I ² C	7	6.6	Removing the initial breakpoint on debug startup	29
2.8	Optional interfaces and power supply	8	6.7	Using the Blueboard with the Raspberry Pi.....	31
2.8.1	Configuring the additional interfaces	9	6.7.1	Preparing the hardware	31
2.8.2	Configuring the power supply.....	10	7.	References	32
2.9	Other supported system architectures	10	8.	Legal information	33
3.	Installation of the LPCXpresso Board	11	8.1	Definitions.....	33
4.	Managing the Demo Reader project with LPCXpresso IDE	12	8.2	Disclaimers.....	33
4.1	Installation of LPCXpresso IDE	12	8.3	Licenses	33
4.2	Extraction of the demo reader project	15	8.4	Trademarks	33
4.3	Run the project.....	17	9.	List of figures.....	35
5.	Associated Projects	21	10.	Contents	36
5.1	Example 1 – Basic Discovery Loop.....	21			
5.2	Example 2 – Advanced Discovery Loop.....	22			
5.3	Example 3 – NFC Forum.....	22			
5.4	Example 4 – MIFARE Classic	22			
5.5	Example 6 – EMVCo Loopback	22			
5.6	Example 7 – EMVCo Polling	22			
5.7	Example 8 – HCE T4T	22			
5.8	Example 9 – NTAG-I2C	23			
6.	Supplementary Notes	24			
6.1	General Software Architecture	24			
6.1.1	Bus abstraction layer.....	24			
6.1.2	Hardware abstraction layer	25			
6.1.3	Protocol abstraction layer.....	25			
6.1.4	Application layer.....	25			

Please be aware that important notices concerning this document and the product(s) described herein, have been included in the section 'Legal information'.