

M23

Direct Thermal Portable Printer

**USER'S
MANUAL**

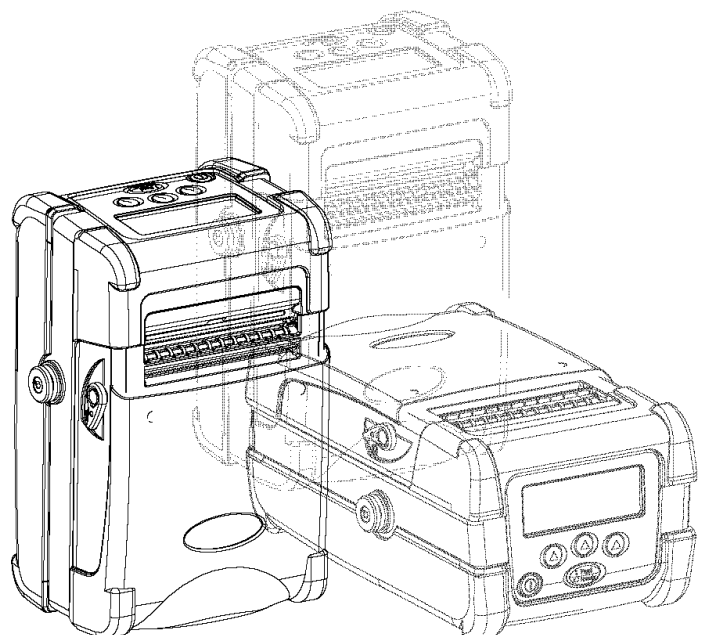

Contents

Copyright Declaration	1
Compliances	1
1. INTRODUCTION	2
1.1 Documentation.....	2
1.2 Unpacking and Inspection	2
1.3 Equipment Checklist	2
1.4 Front View.....	3
1.5 Rear View.....	5
2. GETTING STARTED	6
2.1 Install the Battery.....	6
2.2 Using the Strap	7
2.2.1 Hand Strap.....	7
2.2.2 Shoulder Strap (Option)	8
2.3 Loading Media.....	9
2.3.1 Loading Continuous Labels for Receipt Paper	9
2.3.2 Loading Die-cut Labels	10
2.3.3 Loading Fan-fold Labels	12
2.4 Connecting the Communication Cable.....	14
2.5 Using the Bluetooth Wireless (Optional)	15
2.6 Charging the Battery	16
3. USING THE DISPLAY AND BUTTONS	18
3.1 LCD Display and Buttons.....	18
3.2 LCD Display Icon Description.....	19
3.3 LCD/Keyboard Operation	20
3.3.1 Turn on/off the Printer	20
3.3.2 Arrow Keys	20
3.3.3 Exit From a Menu.....	20
3.3.4 Cancel the Error Status	20
4. LCD MENU OVERVIEW.....	21
4.1 Setup.....	23
4.1.1 Printer Setup	23
4.1.2 Sensor.....	27
4.1.3 Serial Comm.....	33

4.1.4 RF Network (Optional)	35
4.1.5 Bluetooth (Optional)	39
4.1.6 Display	40
4.1.7 Power Manager (Low Power, Shut Down).....	41
4.2 File Manager	42
4.2.1 File List	42
4.2.2 Avail. Memory	43
4.2.3 Del. All Files.....	43
4.3 Diagnostics	44
4.3.1 Print Config.	44
4.3.2 Dump Mode	45
4.3.3 Battery	45
4.3.4 Print Head.....	45
4.3.5 Display	46
4.3.6 Buttons	46
4.4 Language.....	48
4.5 Service	49
4.5.1 Initialization	49
4.5.2 Mileage Info.	50
5. PRINTING LABELS	51
5.1 Connect with a Cable to Print	51
5.2 Connect by Radio (Optional)	51
5.3 Stand-alone Printing.....	52
6. TROUBLESHOOTING	53
7. MAINTENANCE	55
8. FIRMWARE UPDATE PROCEDURE	58
8.1 Update Firmware Via Serial Port.....	58
8.2 Update Firmware Via USB Port.....	61
9. POWER ON UTILITIES	62
9.1 Printer initialization.....	62
9.2 Ignore AUTO.BAS	64

Copyright Declaration

Information in this manual is subject to change without notice and does not represent a commitment on the part of TSC Auto ID Technology Co., Ltd.. No part of this manual may be reproduced or transmitted in any form by any means, for any purpose other than the purchaser's personal use, without the expressed written permission of TSC Auto ID Technology Co., Ltd..

The TrueType font engine is developed from the "FreeType Project" by David Turner, Robert Wilhelm, and Werner Lemberg. All other products referred on this document are the trademark or the registered trademark of each belonged companies.

Compliances

CE Class B:

EN55022:1998+A1:2000+A2:2003:

EN55024:1998+A1:2001+A2:2003:

EN 61000-4 SERIES REGULATIONS

ETSI EN 301 489-17:V1.2.1(2002-08)

FCC:

CFR 47, Part 15/CISPR 22 3RD EDITION:1997, Class B

ANSI C63.4:2003

CANADIAN ICES-003

C-Tick:

AS/NZS CISPR22 (Class B)

UL, CUL

UL 60950 3rd

TÜV-GS:

EN60950: 2000

Wichtige Sicherheits-Hinweise

1. Bitte lesen Sie Diese Hinweis sorgfältig durch
2. Heben Sie diese Anleitung für den späteren Gebrauch auf.
3. Vor jedem Reinigen ist das Gerät vom Stromnetz zu trennen. Verwenden Sie Keine Flüssig-oder Aerosolreiniger. Am besten eignet sich ein angefeuchtetes Tuch zur Reinigung.
4. Die Netzanschlußsteckdose soll nahe dem Gerät angebracht und leicht zugänglich sein.
5. Das Gerät ist vor Feuchtigkeit zu schützen.
6. Bei der Aufstellung des Gerätes ist auf sicheren Stand zu achten. Ein Kippen oder Fallen könnte Beschädigungen hervorrufen.
7. Beachten Sie beim Anschluß an das stromnetz die Anschlußwerte.
8. Dieses das Gerät kann bis zu einer Außentemperatur von maximal 40°C betrieben werden.

1. Introduction

Thank you for purchasing TSC M23 direct thermal printer.

M23 is a portable printer, which can accept varieties of media, such as labels, receipt, tag, and fan-fold paper. With LCD display, it is more user friendly for operation and more easily for understanding printer status. With 802.11b WiFi and Bluetooth connectivity, M23 extends the mobile printing technology needs.

1.1 Documentation

This document provides an easy reference for operating the TSC M23 Printer. The online version of the Programmer's manual, or more information can be downloaded from service and support web site as an Adobe® Acrobat® Reader file.

1.2 Unpacking and Inspection

This printer has been specially packaged to withstand damage during shipping. Please carefully inspect the packaging and printer upon receiving the bar code printer. Please retain the packaging materials in case you need to reship the printer.

1.3 Equipment Checklist

Unpacking the printer, the following items are included in the carton.

- One M23 printer
- One software CD disk
- One hand strap
- One Lithium-ion battery
- One single bay battery charger and power adapter
- One quick start guide

If any parts are missing, please contact the Customer Service Department of your purchased reseller or distributor.

1.4 Front View

Context-sensitive keys

Supply door
release button

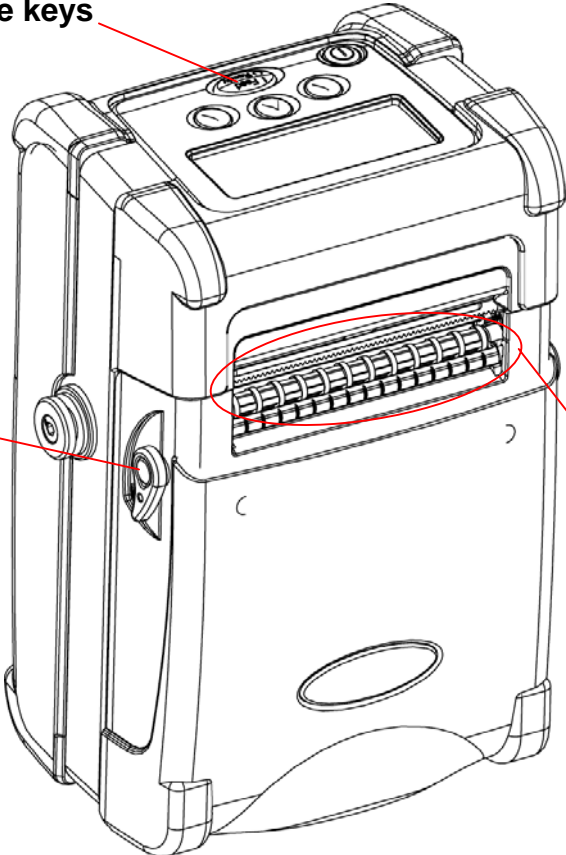

Paper exit chute

⚠Caution:
Hazardous parts. Keep fingers and other body parts away.

Tear plate (for label)

Peel roller

Tear bar (for liner)

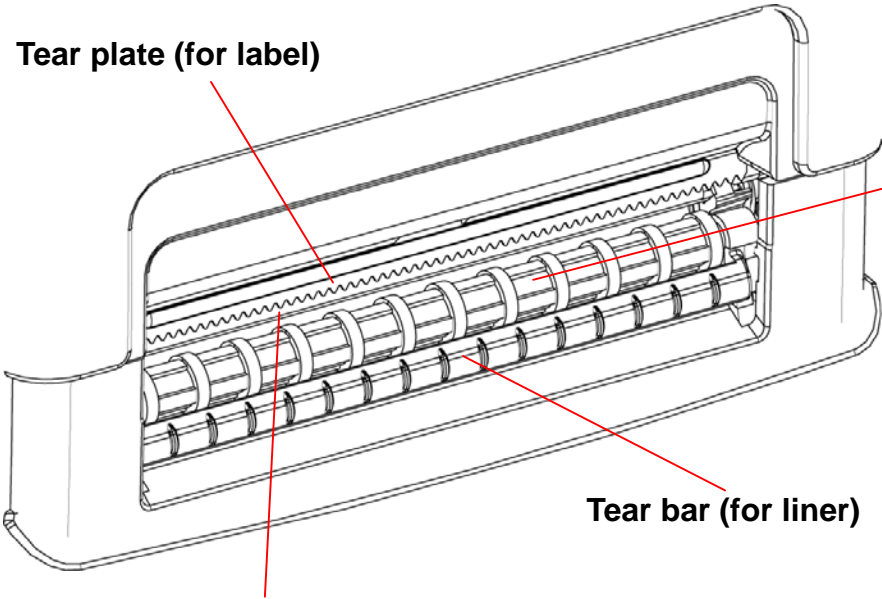

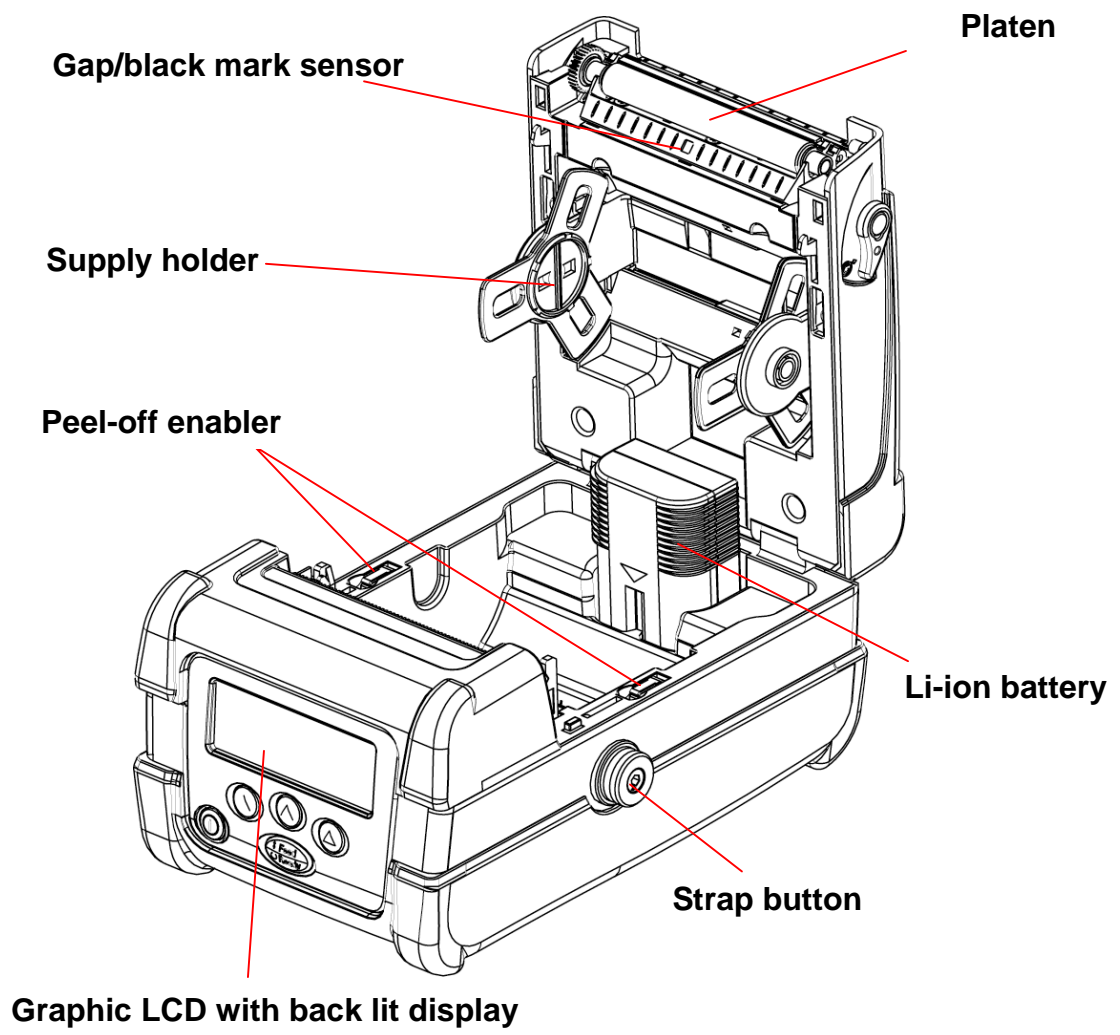

1.5 Rear View

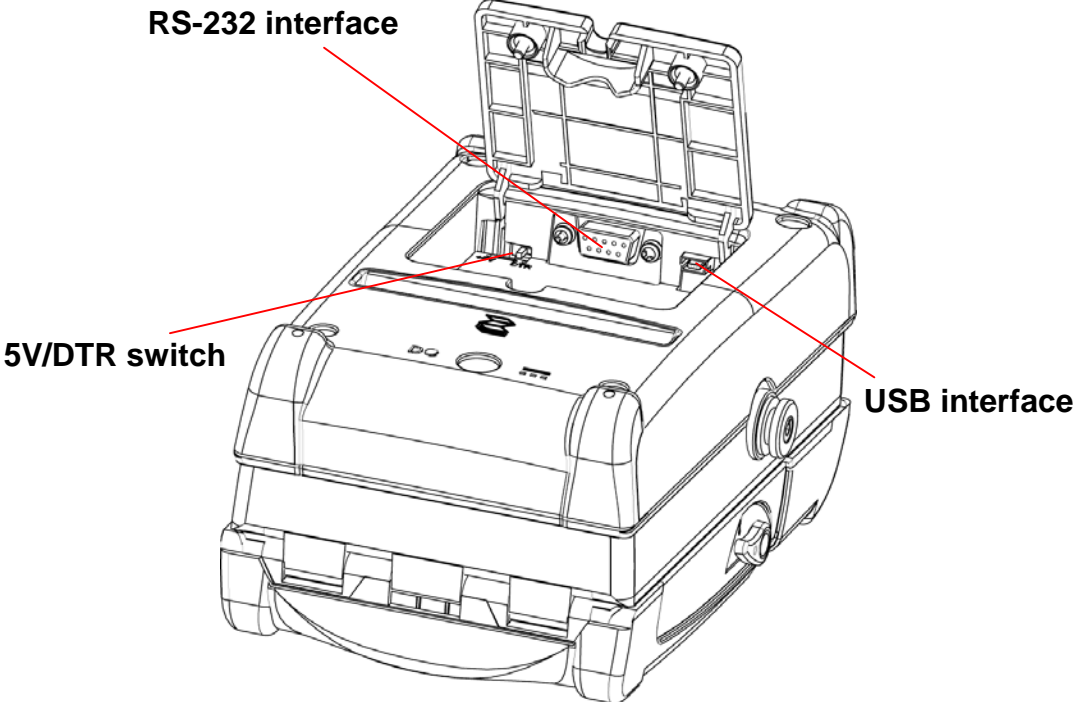
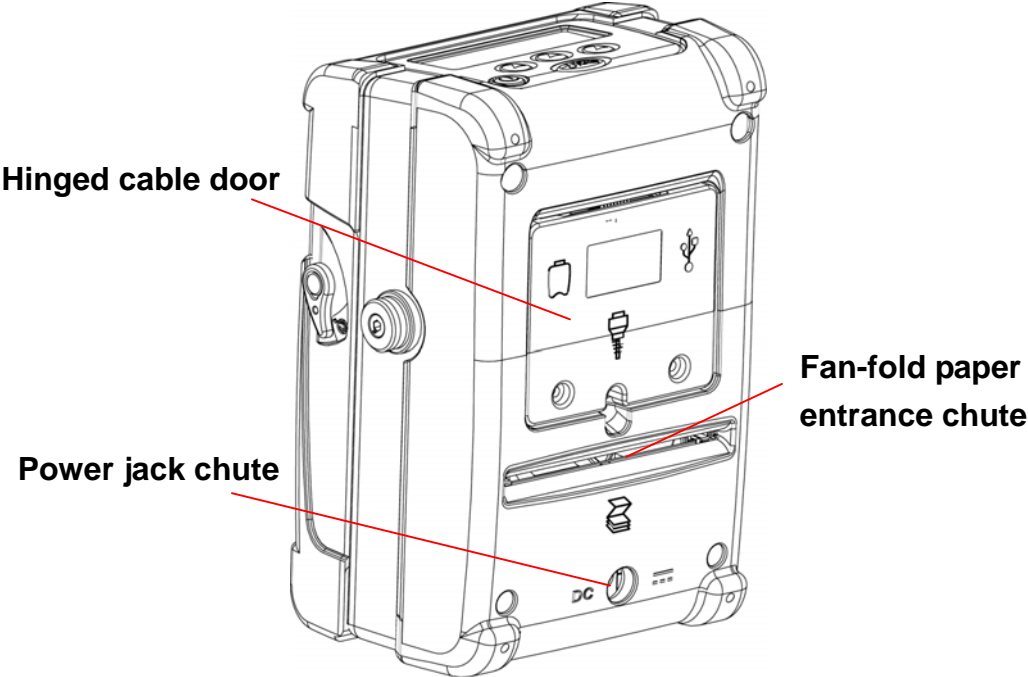

2. Getting Started

2.1 Install the Battery

1. Open the supply door by pulling outward on the release buttons located on either side of the printer. The supply door should swing open.

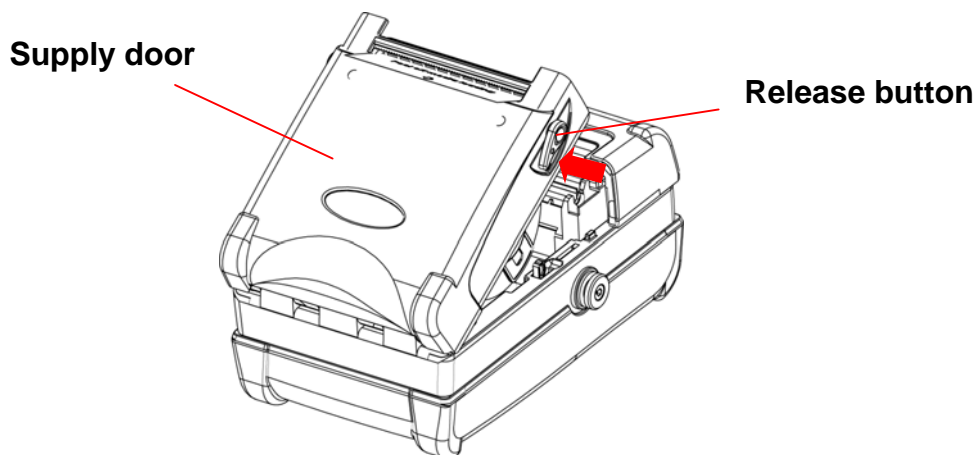

2. Insert the connector end of the battery into the printer.

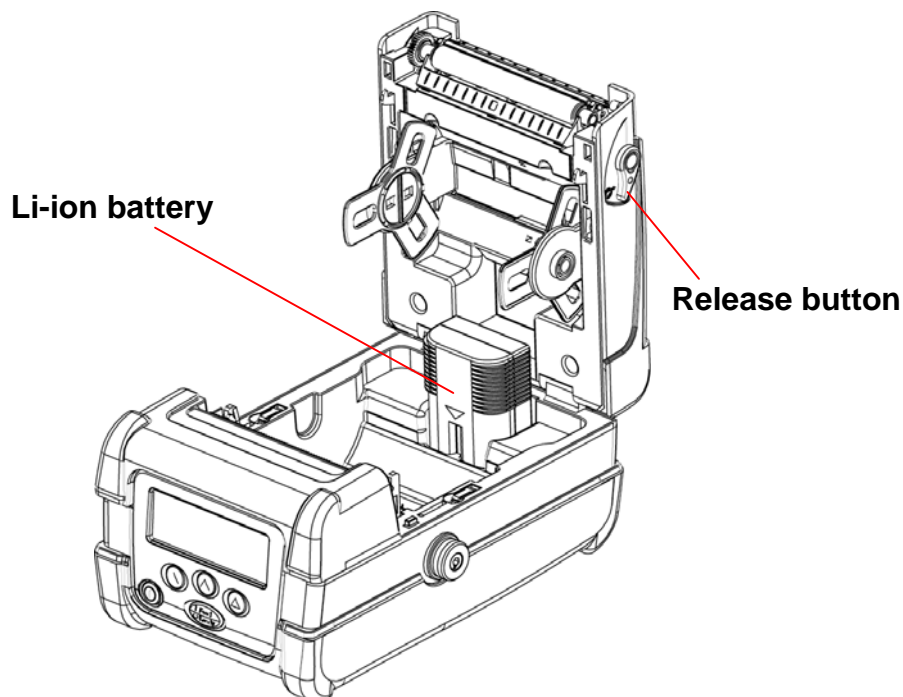

3. After loading media, close the supply door until the release buttons click into place.

2.2 Using the Strap

2.2.1 Hand Strap

1. Clip both rings of the hand strap onto the strap buttons by placing each O-ring over the strap button and gently pulling up on the strap until the strap locks into place.

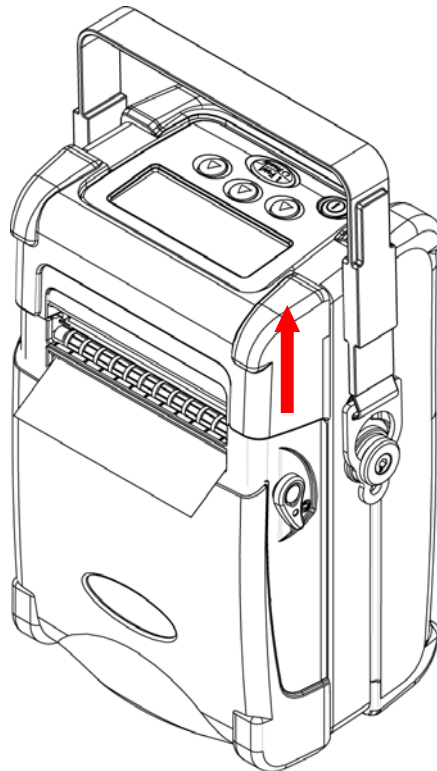
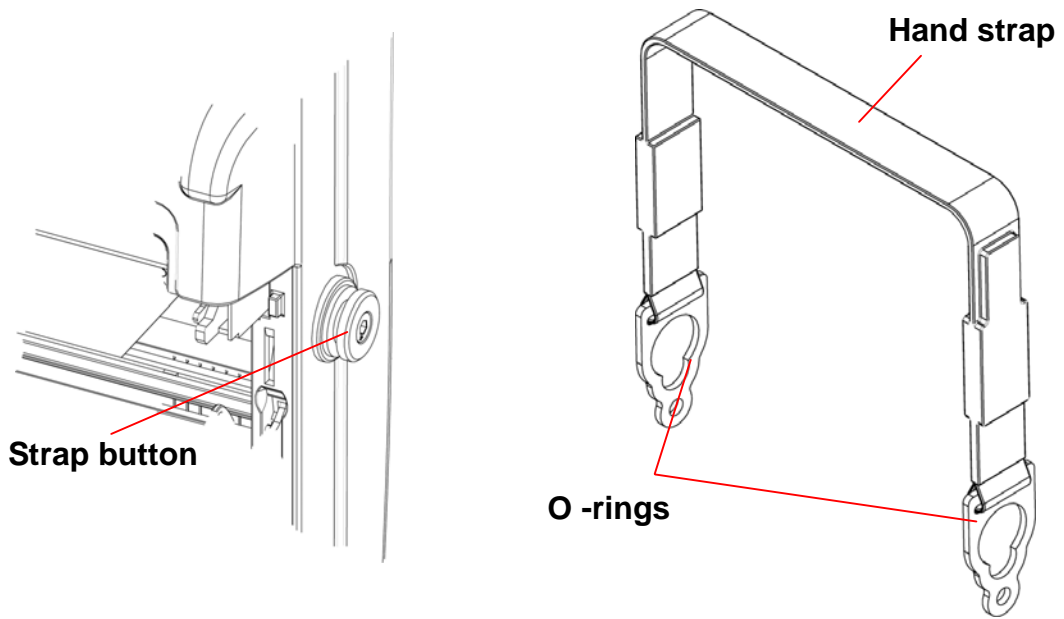

2.2.2 Shoulder Strap (Option)

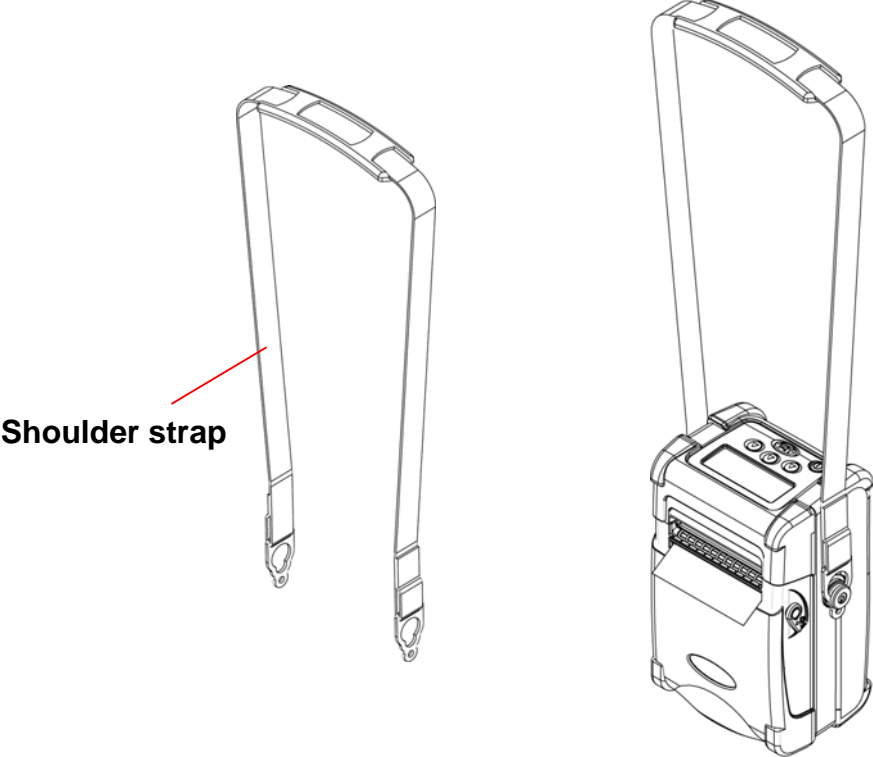

2.3 Loading Media

2.3.1 Loading Continuous Labels for Receipt Paper

1. Open the supply door by pulling outward on the release buttons on both sides of the printer.
2. Pull supply holder tabs apart and insert a new roll of media. Make sure the media is positioned so it unwinds from the top as shown.

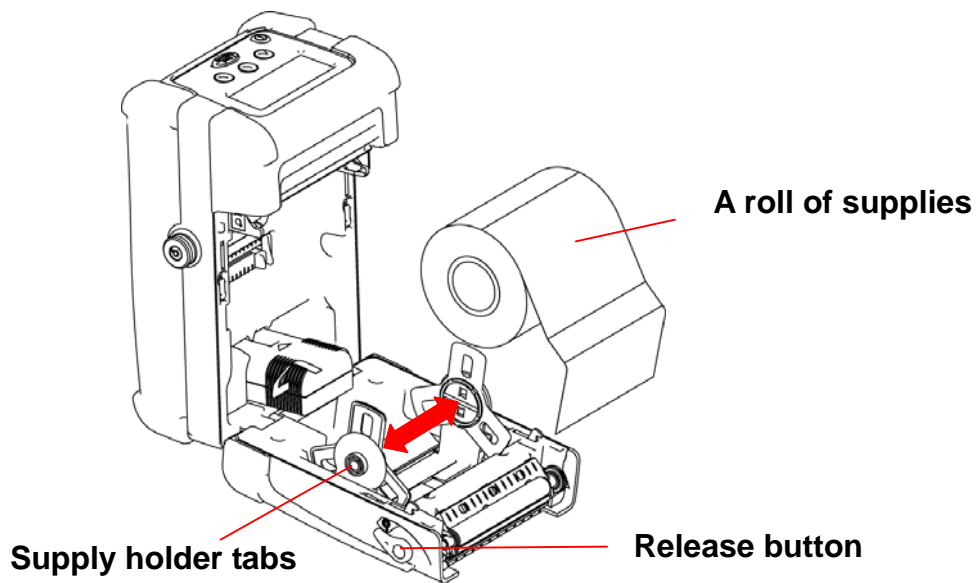

3. Pull out enough supply to lie across the exit chute.

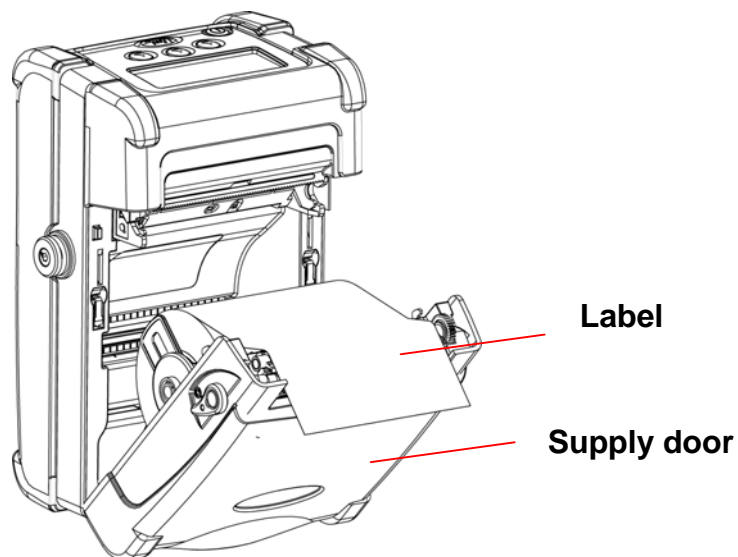

4. Close the supply door until the release buttons click into place.

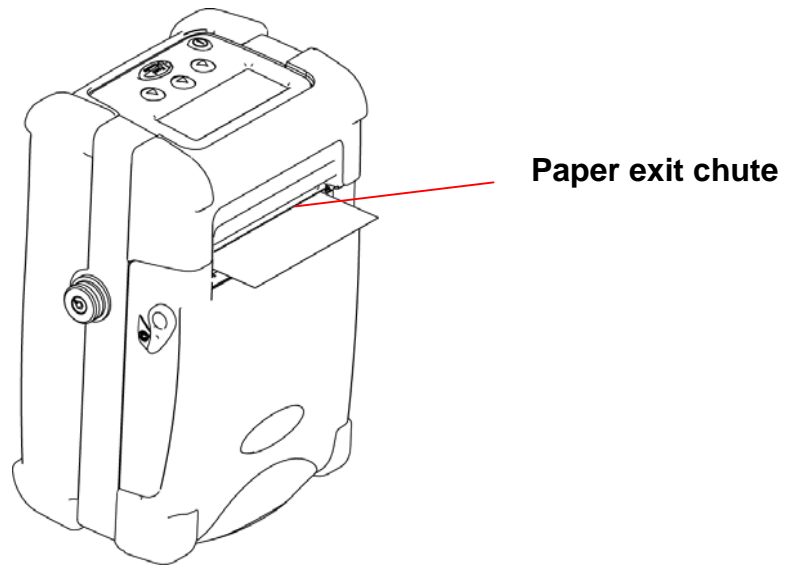

Note: Please set the sensor type as Continuous.

2.3.2 Loading Die-cut Labels

1. Open the supply door by pulling outward on the release buttons on both sides of the printer.

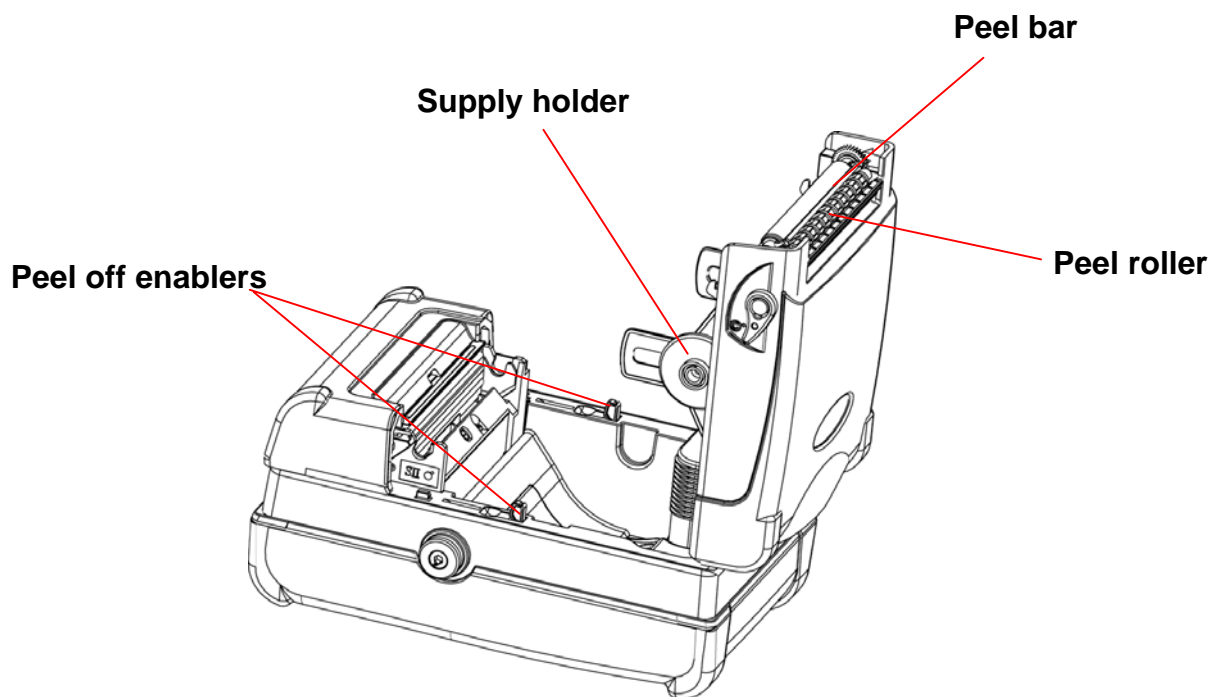

2. Lift up the peel off enablers on both sides.

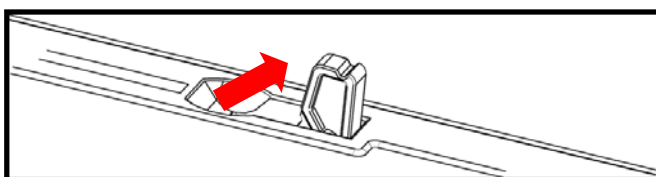

Lift **up** the peel off enablers

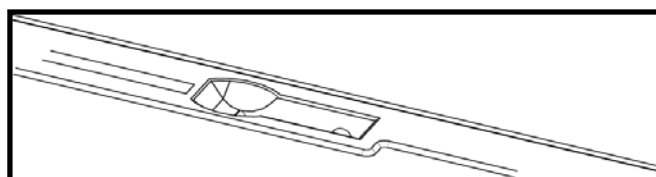

Push **down** the peel off enablers

3. Pull supply holder tabs apart, and insert a roll of labels. Make sure the supply unwinds from the top as shown.

Note: Calibrate the gap/black mark sensor when changing media.

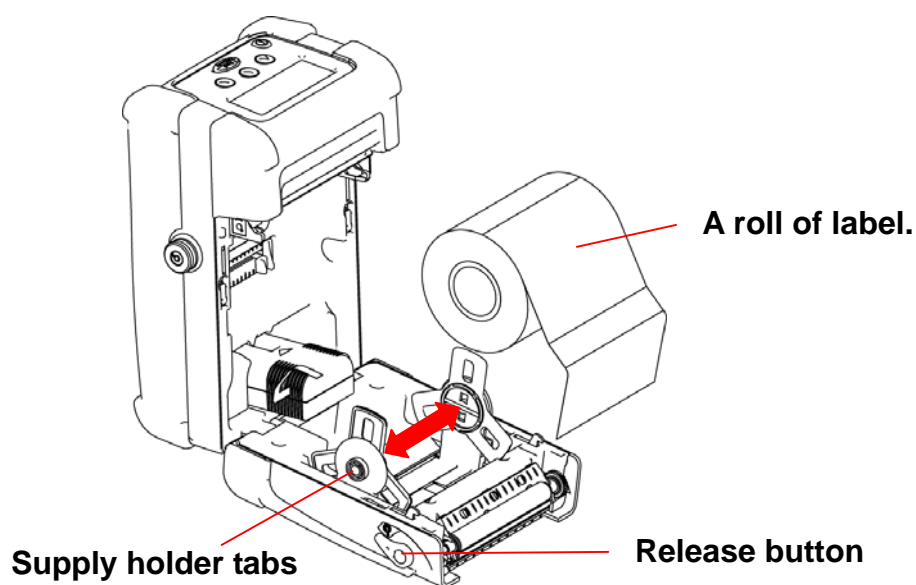

4. Remove a couple of labels from the liner. Insert the liner through the gap between peeler bar and peel-off roller.

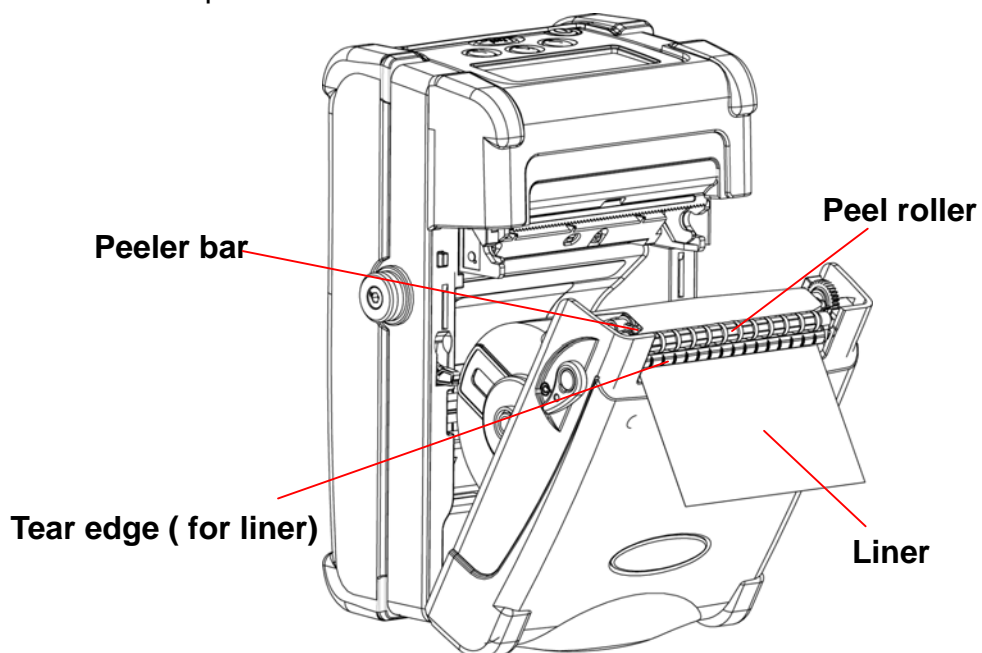

5. Close the supply door.

6. Press the  button once or twice to advance the labels until the liner is separates from the label.

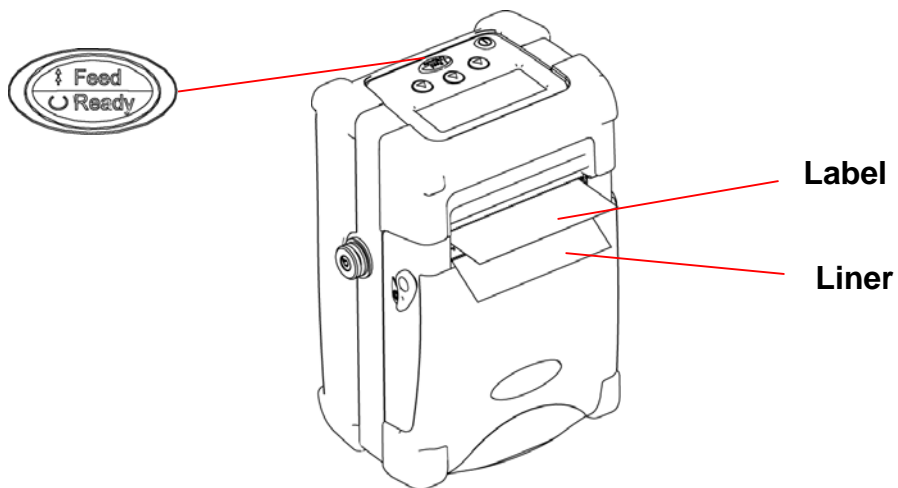

2.3.3 Loading Fan-fold Labels

1. Open the supply door by pulling outward on the release buttons on both sides of the printer.
2. Pull supply holder tabs apart to insert a 3" paper core to keep supply holder wide open.

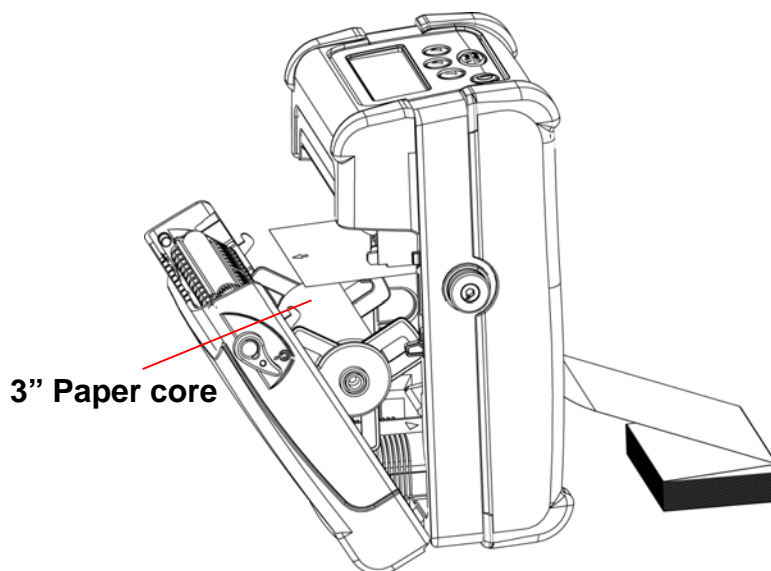

3. Insert the fan-fold paper through the fan-fold paper entrance chute and pass over the paper exit chute.

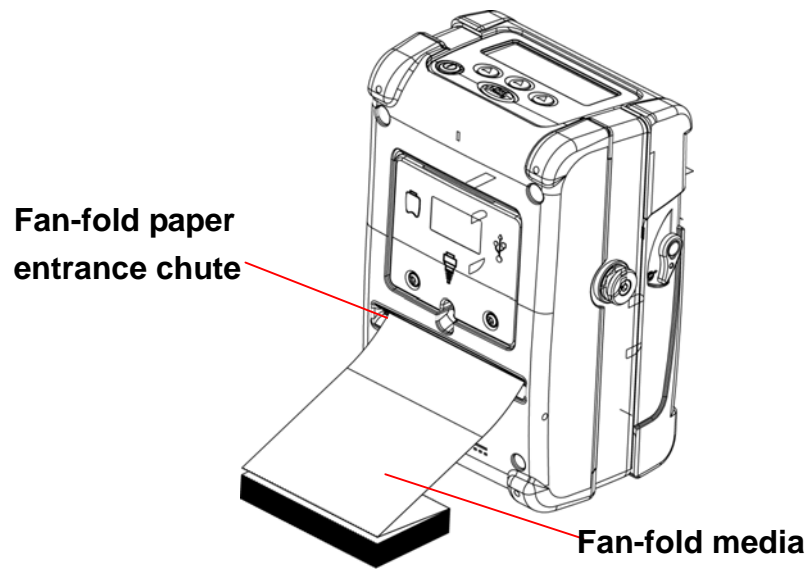

4. Adjust the paper guides by sliding to fit the paper width.

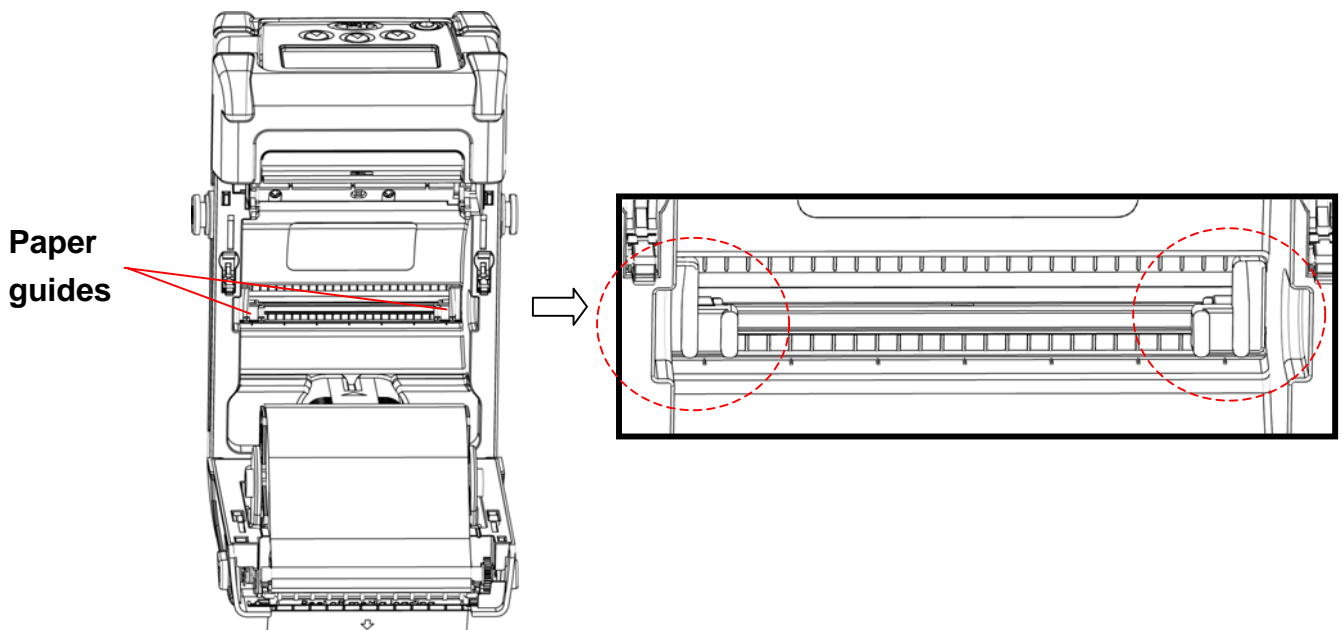

5. Close the supply door.

6. Calibrate the media if necessary.

Note: Please calibrate the gap/black mark sensor when changing media.

2.4 Connecting the Communication Cable

1. Open the hinged cable door by loosening the two screws. Lift up on the door.

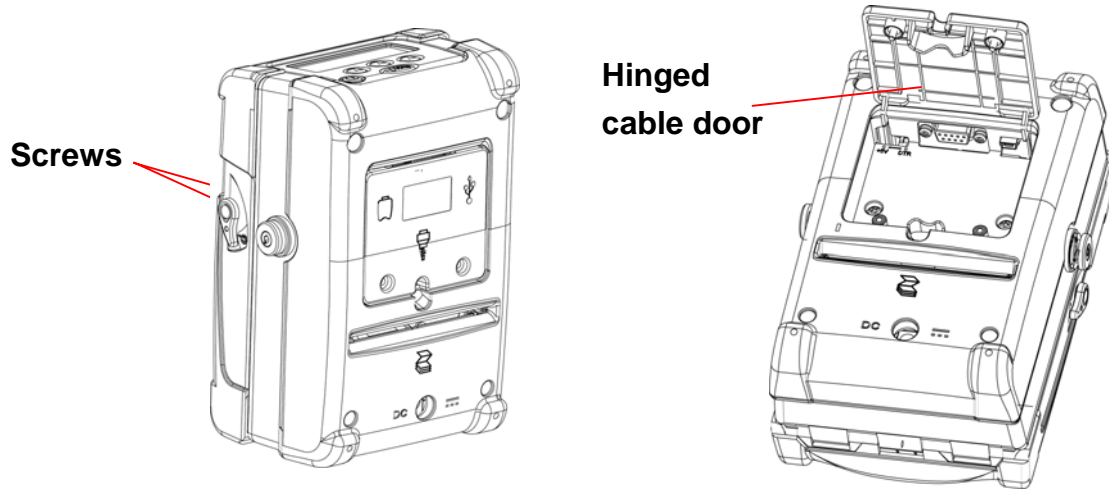

2. Plug the null modem cable into the RS232 port. (Or plug the USB cable into the USB port.)

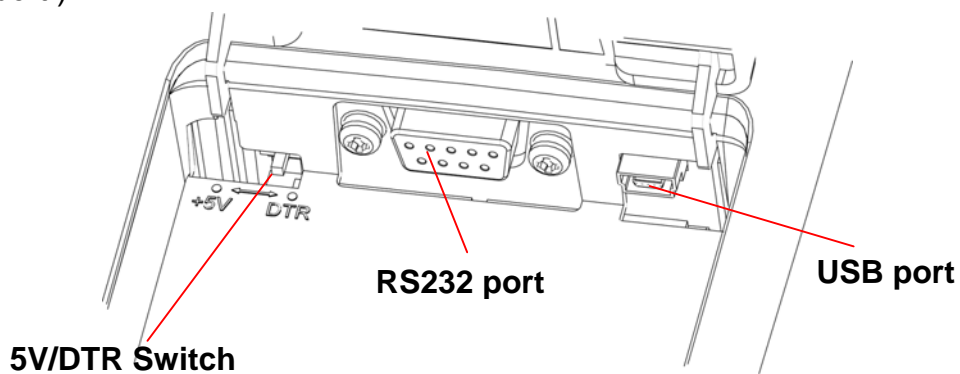

3. Place the cable in the cable cavity.

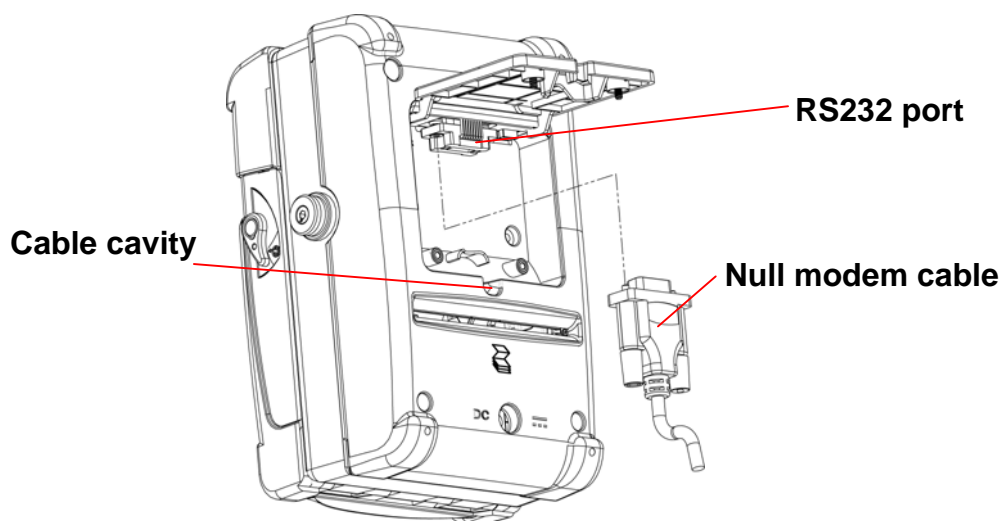

4. Close the hinged cable door and tighten the screws.

2.5 Using the Bluetooth Wireless (Optional)

1. Open the hinged cable door by loosening the two screws and lifting up on the door.
2. Set the +5V / DTR switch to the +5V position.

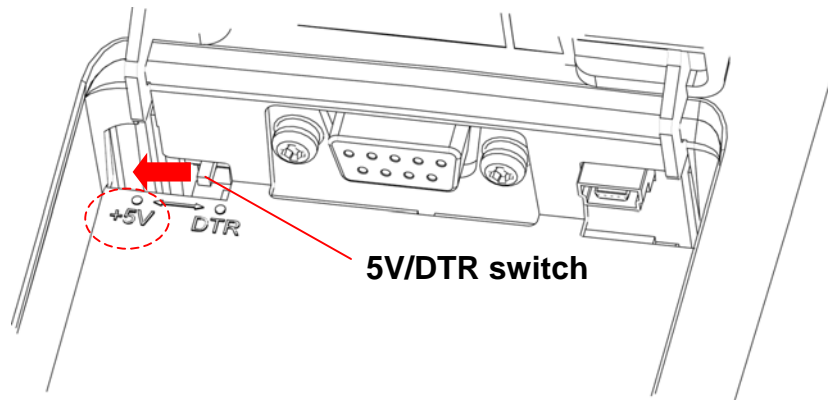

3. Plug in the Bluetooth dongle into the RS-232 port.

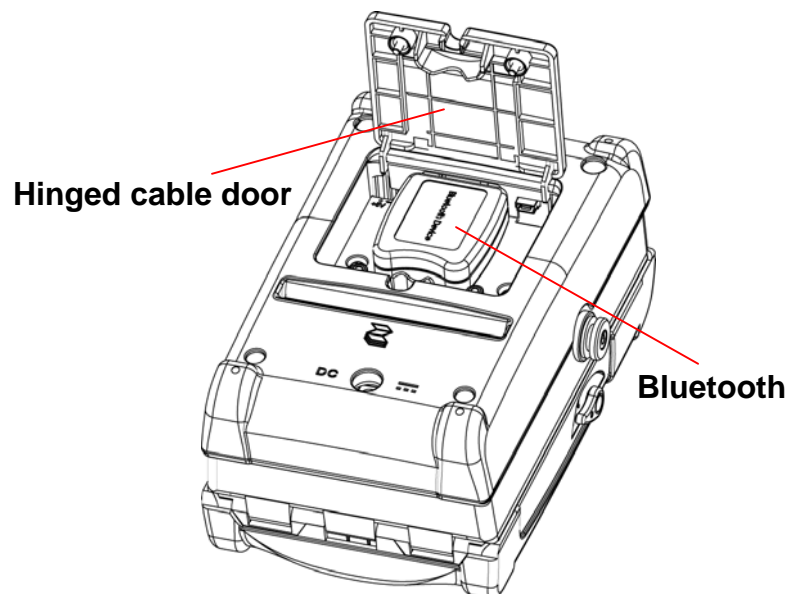

4. Close the hinged cable door and tighten the screws.
5. Then, please to refer the section 4.1 to calibrate the bluetooth.

2.6 Charging the Battery

1. Open the printer supply door and remove the battery.
2. Insert the battery into the charger station.

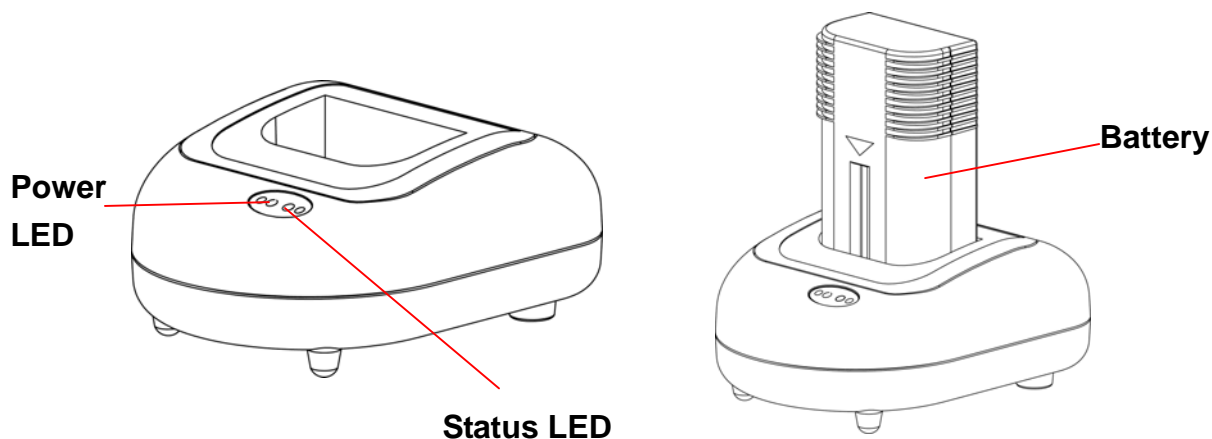

Power LED	Description
Red	Power is on
Off	Power is off

Status LED	Description
Red	Charging battery
Amber	Battery is 70% charged
Green (Solid)	Battery is completely charged
Green (Blinking)	Charger error
Off	No battery

Note:



1. If Power LED is solid red and Status LED is green blinking, please remove the battery and check if the terminals inside the charger are shorted by foreign object. Unplug the charger power adapter from the outlet and remove the object between “+” and “-” terminals. Install the battery to the charger for charging again. If problem still exists, please contact your purchased reseller for service.
2. It takes 2 to 3 hours to fully charge the battery before the first time usage. The

lifetime of the battery is 300 times for charge/discharge cycles.



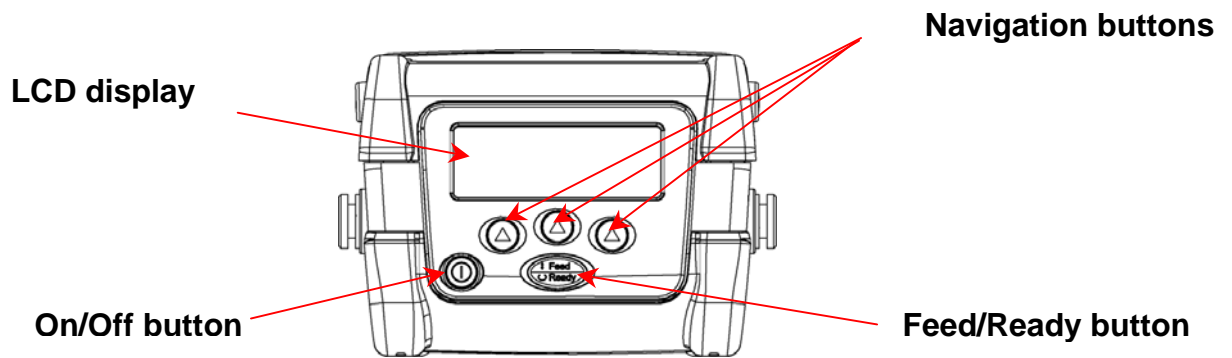



3. Using the Display and Buttons

3.1 LCD Display and Buttons



Icon	Description
	Turns the printer on and off.
	Advances label or returns the display to the previous menu.
	Three buttons that selecting options on the display.

3.2 LCD Display Icon Description

Icon	Description
	Enter the menu
→]	Enter cursor located option
	Scroll up
	Scroll down
	Cursor location
+	Increase the setting value
-	Decrease the setting value
×	Cancel
	OK/select
	Return the display to the next higher menu.
	Pause and display the battery voltage



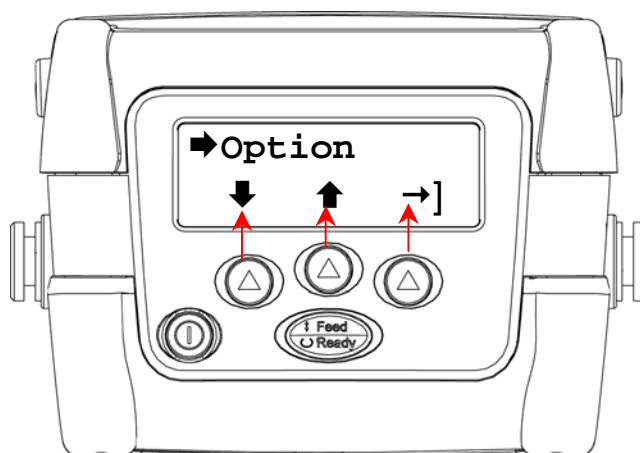



3.3 LCD/Keyboard Operation







3.3.1 Turn on/off the Printer

Hold the  button to turn on/off printer.

3.3.2 Arrow Keys

- Press the  button under the  LCD icon to scroll down the menu list
- Press the  button under the  LCD icon to scroll up the menu list.
- Press the  button under the  LCD icon to enter cursor located option

3.3.3 Exit From a Menu

1. Press the  button to exit from a menu or cancel a setting and return to the next higher menu.
2. When the cursor  icon is pointed to the "Exit", press the  button, which is under the  LCD icon on the display, to exit from an option.

3.3.4 Cancel the Error Status

Press the  button to cancel the error status to resume printer back to normal.

4. LCD Menu Overview

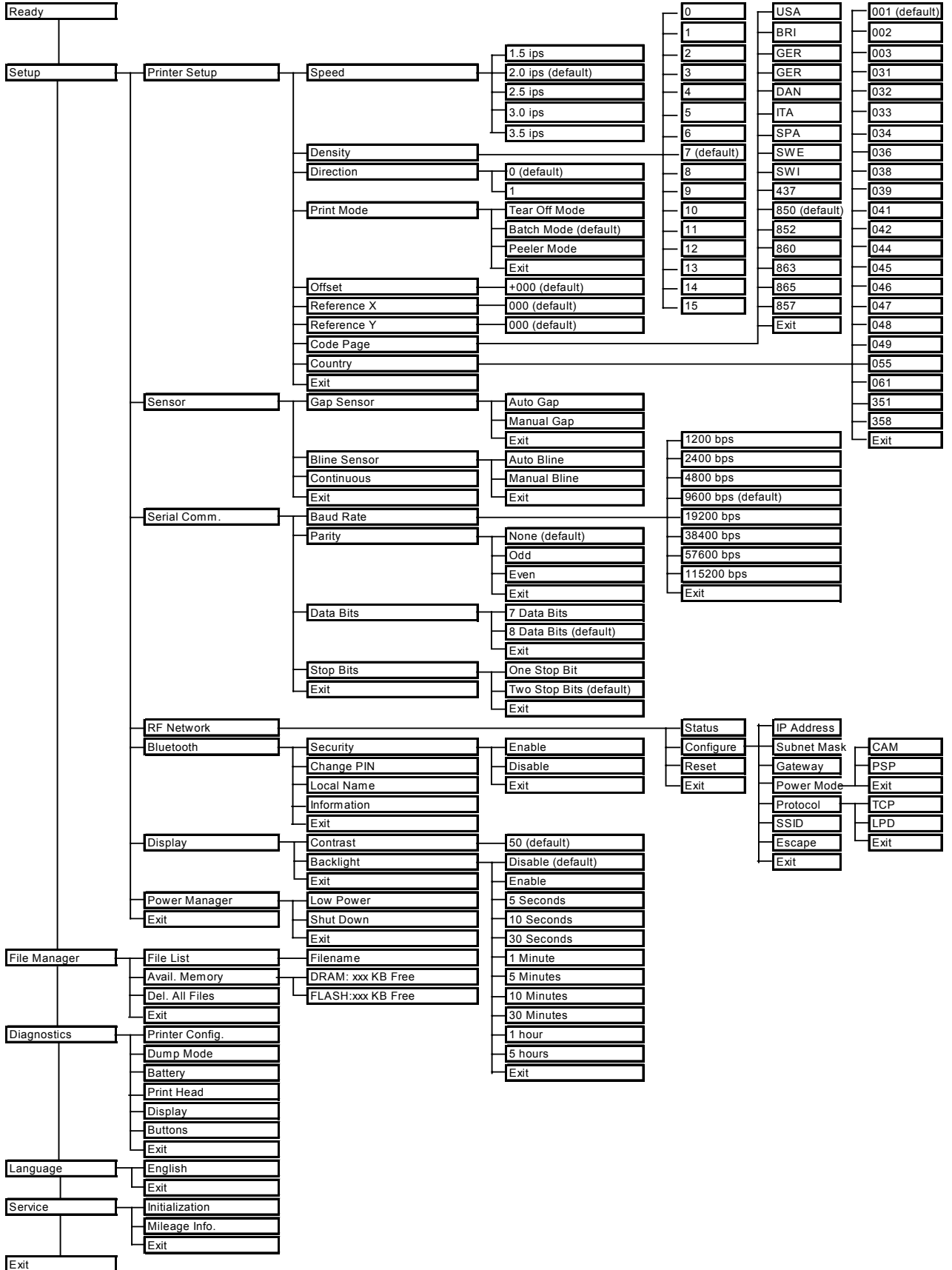

Main Menu

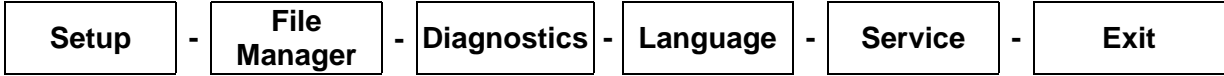

1. Turn on the printer by pressing and holding the  button until the display turns on. The display flashes printer version information, battery voltage gauge, and then you see:

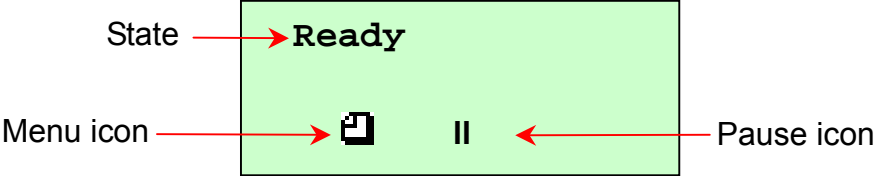

Note: At ready states press || icon can check battery voltage gauge. (Press the same button to go back to Ready states.)

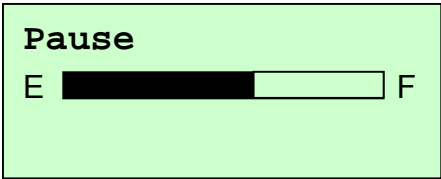

2. Press the  button under the  icon to enter the Main menu.

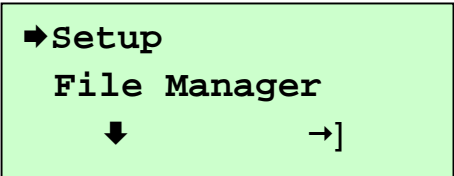

4.1 Setup

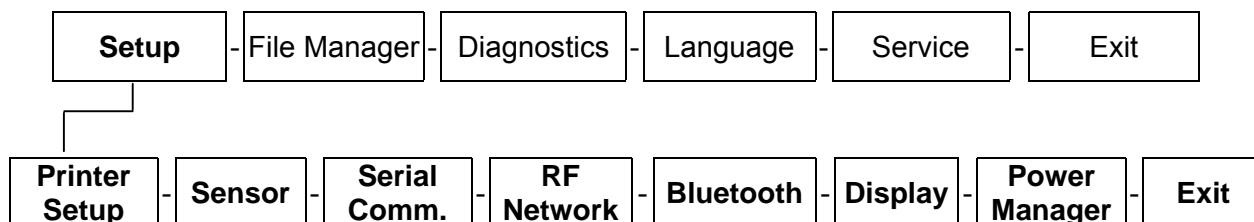

4.1.1 Printer Setup

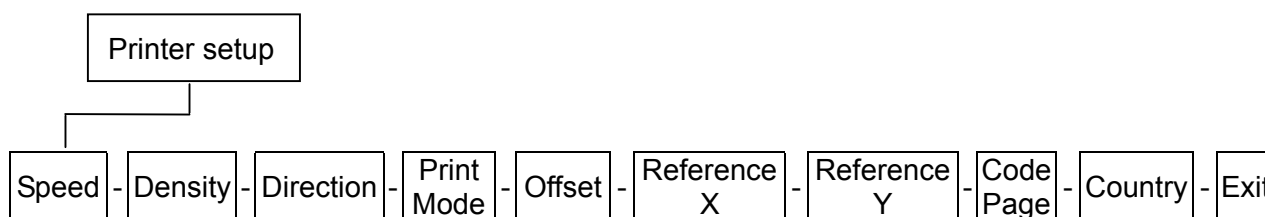

4.1.1.1 Speed:

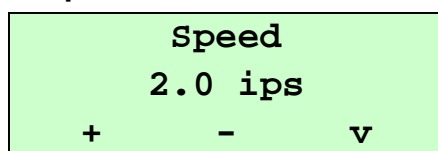

Use this option to setup print speed. The available print speed is between 1.5~3.5 ips and increment/decrement is 0.5 ips. The default print speed is 2.0 ips (50mm/sec).

Press  button under “+” icon to raise the print speed, and “-” icon to lower it, and “V” icon to set it into printer.

Note:

1. Media width, label printing content, density setting and battery voltage will affect printing speed. Printer will adjust the printing speed automatically to optimize printing quality.
2. In peel off mode, the printing speed will be set to 1.5 ips automatically.

4.1.1.2 Density:

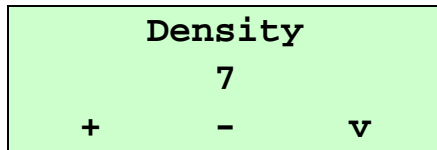

Use this option to setup printing darkness. The available setting is from 0 to 15, and the step is 1. Printer default density is 7. You may need to adjust your density based on selected media.

Press  button under “+” / “-” icons to increase/decrease the printing darkness. Press button under “v” icon to enable the setting.

Note:

Density setting will affect printing speed. Printer will adjust the printing speed automatically to optimize the printing quality.

4.1.1.3 Direction:

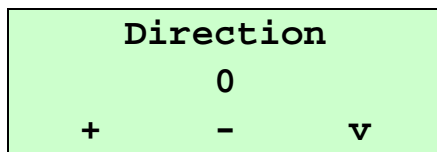

The direction setting value is either 1 or 0. Use this option to setup the printout direction. Printer default printout direction is DIRECTION 0.

Press  button under “+” icon to set the direction as 1, and “-” icon to set it as 0, and “v” icon to enable the setting. The following 2 figures are the printouts of DIRECTION 0 and 1 for your reference.

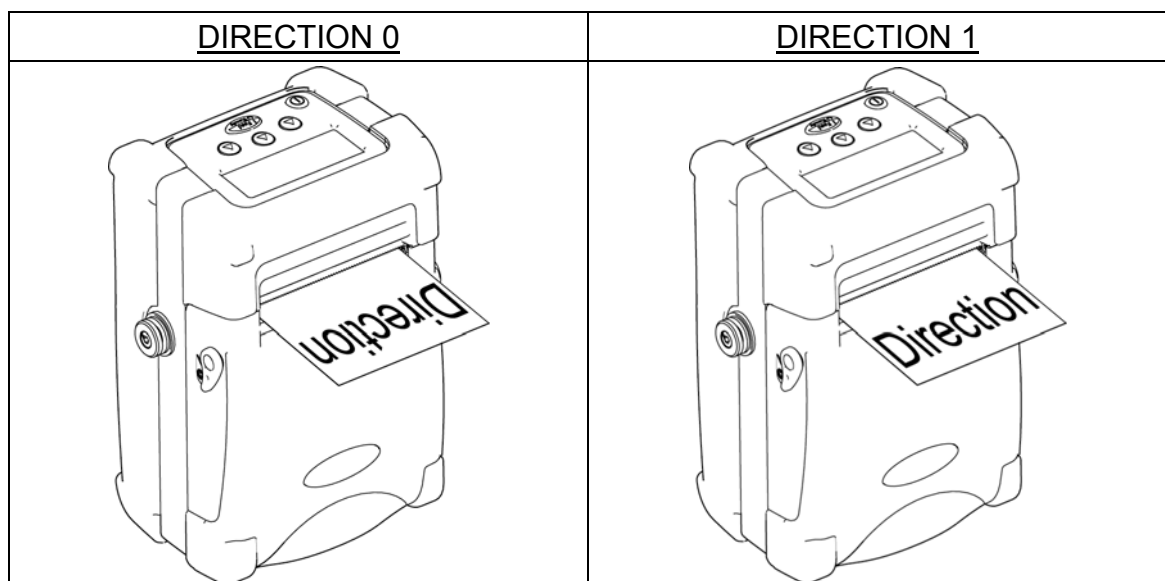

4.1.1.4 Print Mode: (Tear Off Mode/Batch Mode/Peeler Mode)

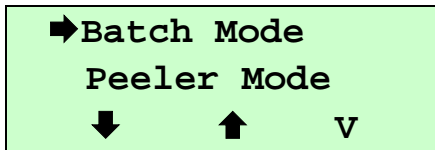

This option is used to set the print mode. Printer default setting is Batch Mode. When enter this list, the print mode in the right side of ➡ icon is the printer current setting. Press ⏪ button under ⬇ and ⬆ icon to select the different print mode, and press ⏩ button under “V” icon to enable the setting.

Printer Mode	Description
Tear Off Mode:	Next label leading edge is aligned to the print head burn line location.
Batch Mode:	Once image is printed completely, label gap/black mark will be fed to the tear plate location for tear away.
Peeler Mode:	Enable the label peel off mode.

4.1.1.5 Offset:

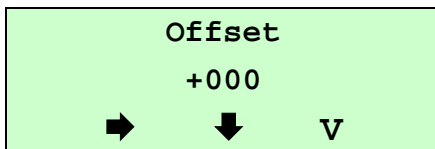

This option is used to fine tune media stop location. Press the ⏪ button under ➡ icon to move the cursor from left digit to right digit, and press the ⏩ button to set the value from “+” to “-” or “0” to “9”. Press the ⏩ button under “V” icon to set the value into printer. The default value is +000.

4.1.1.6 Reference X & Reference Y:

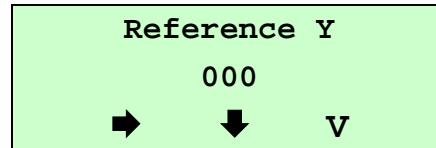
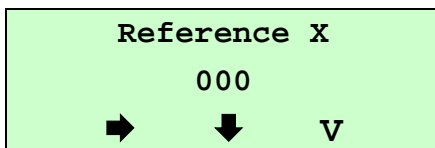

This option is used to set the origin of printer coordinate system horizontally and vertically. Press the ⏪ button under ➡ icon to move the cursor from left digit to right digit, and press the ⏩ button under ⬇ icon to set the value from “0” to “9”. Press the ⏩ button under “V” to set the value into printer. The default value is 000.

4.1.1.7 Code Page:

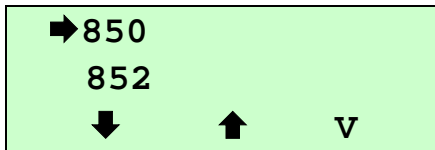

Use this option to set the code page of international character set. For more information about code page, please refer the programming manual.

When enter the code page list, the code page in the right side of ➡ icon is the printer current setting.

Press the button under ↓ and ↑ icon to select the code page, and press the button under “V” icon to enable the setting.

7-bit		8-bit	
code page name	International Character Set	code page number	International Character Set
USA	USA	437	United States
BRI	British	850	Multilingual
GER	German	852	Slavic
FRE	French	860	Portuguese
DAN	Danish	863	Canadian/French
ITA	Italian	865	Nordic
SPA	Spanish		
SWE	Swedish		
SWI	Swiss		

4.1.1.8 Country:

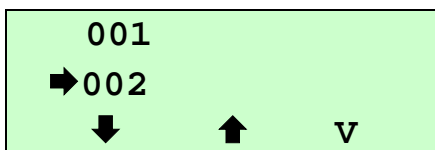

Use this option to set the country code for the LCD display. Press the button under ↓ and ↑ icon to select the country code, and press the button under “V” icon to set the value into printer. When enter this list, the country code in the right side of ➡ icon is the printer current setting.

Code	Country	Code	Country	Code	Country	Code	Country
001	USA	034	Spanish (Spain)	044	United Kingdom	055	Brazil
002	Canadian-French	036	Hungarian	045	Danish	061	English (International)
003	Spanish (Latin America)	038	Yugoslavian	046	Swedish	351	Portuguese
031	Dutch	039	Italian	047	Norwegian	358	Finnish
032	Belgian	041	Switzerland	048	Polish		
033	French (France)	042	Slovak	049	German		

4.1.2 Sensor

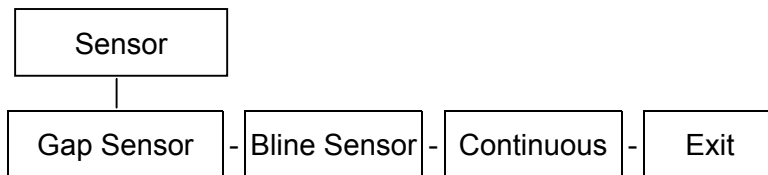

This option is used to set the media sensor type and calibrate the selected sensor. We recommend to calibrate the sensor before printing when changing the media.

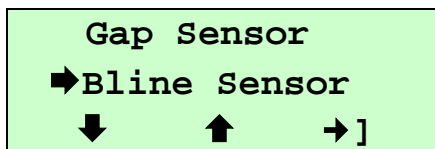

When you enter this option, the sensor type in the right side of ➡ icon is the printer current setting.

Press the button under and to select the sensor type, and press the under “➡]” icon to enter sensor detecting mode.

4.1.2.1 Gap Sensor:

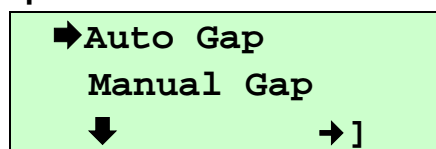

Press the button under and to select the sensor detecting mode, and press the button under ➡] icon to detect sensor strength.

4.1.2.2.1 Auto Gap:

When enter the [Auto Gap] option, you will see following message.
Normally, we use this option to calibrate the sensor sensitivity.

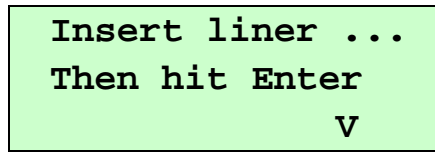



Insert liner ...
Then hit Enter
V

Insert liner between the gap sensors, and press the  button under “V” icon to start sensor calibrate.

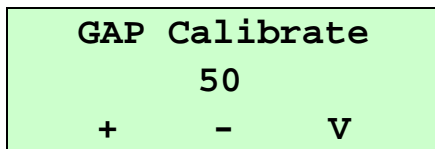
Note: Please make sure the only liner is placed between the gap see-through type sensor.



GAP Calibrate
50
+ - V

Press the  button under “+” and “-” icon to increase and decrease Stock AD value, and press the  under “V” icon to detect sensor sensitivity.

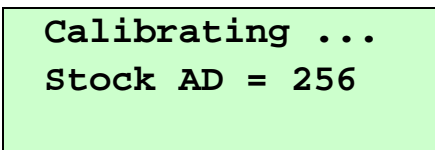

Calibrating ...
Stock AD = 256

When “SUCCESSFUL” is shown on the LCD display, press the  button under “U” to return to the previous page.

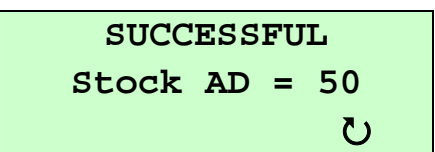



SUCCESSFUL
Stock AD = 50
U

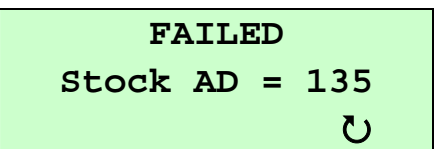

If “FAILED” is shown on the LCD display, please check if only liner is placed between the see through type gap sensor.



FAILED
Stock AD = 135
U

Please follow the steps below to calibrate sensor sensitivity again.

1. Press the button  under “U” icon to return to “Gap Sensor” menu.
2. Press the button  under “→]” icon to enter “Auto Gap” menu.

3. After insert liner between the see through type gap sensor, press the button  under “V” icon to continue.
4. Press the button  under “+” icon to increase Stock AD value by 50 increment. And press the button  under “V” icon to calibrate the sensor sensitivity.

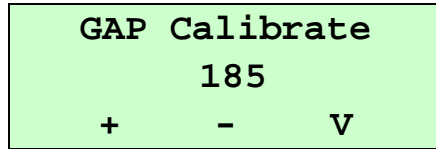

4.1.2.1.2 Manual Gap:

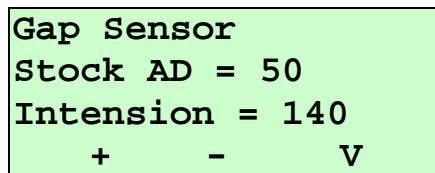

If Auto Gap sensor calibration can not apply to the media, please use Manual Gap function to calibrate sensor manually. This function can be used to fine tune sensor sensitivity. When enter [Manual Gap] option, you will see following message.

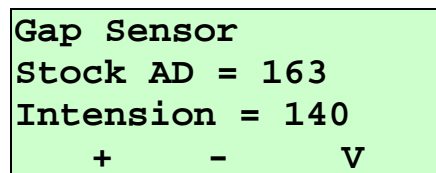

Stock AD on liner



Stock AD on paper

Press the  button under “+” and “-” to increase and decrease sensor intension, and press the  under “V” to set the value to printer.

When adjust the sensor sensitivity manually, we can get the different Stock AD on liner and paper in each sensor intension. The difference between these two values must be larger than 50 levels then printer can register label position correctly.

4.1.2.2 Black Sensor:

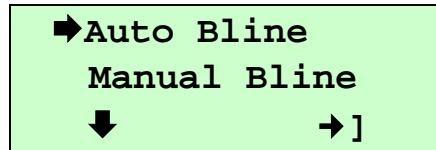

Press the button under ↓ and ↑ icon to select the sensor calibration mode, and press the under “→]” icon to start sensor calibration.

4.1.2.2.1 Auto Bline:

When enter the [Auto Bline] option, you will see following message.
Normally, we use Auto Bline to calibrate sensor sensitivity.

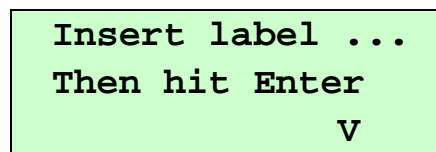

Insert label on the black mark sensors, and press the button under “V” icon to start sensor calibration.

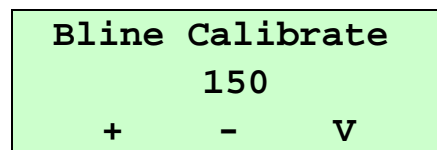

Note:

DO NOT align black mark to the black mark sensor when calibrate black mark sensor or sensor will be calibrated incorrectly.

Press the button under “+” and “-” icon to increase and decrease Stock AD value, and press the under “V” icon to calibrate sensor.

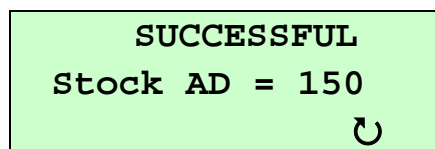
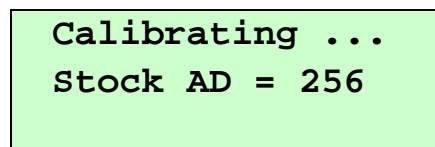



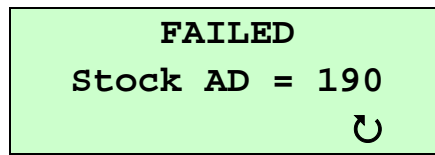

When sensor is calibrated successfully, press the button under “⌂” icon to return to the previous page.

If “FAILED” is shown on the LCD display, please check if only paper

(without black mark) is placed on the black mark sensor.



If yes, please follow the following steps to calibrate sensor sensitivity again.

1. Press the button  under “U” icon to return to Bline Sensor menu.
2. Press the button  under “→]” icon to enter “Auto Bline” menu.
3. After insert paper on the black mark sensor, press the button  under “V” icon to continue.
4. Press the button  under “+” icon to increase Stock AD value by 50. And press the button  under “V” icon to calibrate the sensor sensitivity.

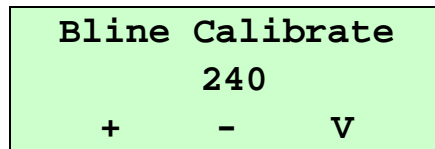

4.1.2.2.2 Manual Bline:

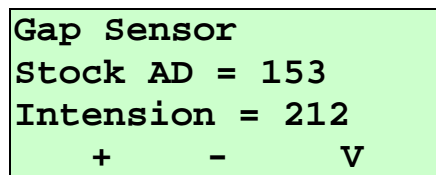

If Auto Bline sensor calibration successfully, it's not necessary to calibrate the sensor manually. This function is used to fine tune sensor sensitivity. When enter the [Manual Bline] option, you will see following message.

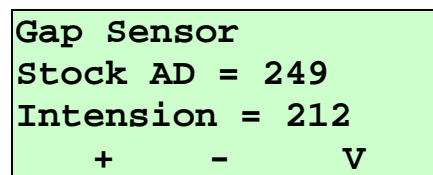

Stock AD on label



Stock AD on black

Press the  button under “+” and “-” to increase and decrease sensor intension, and press the  under “V” to set the value to printer

When adjust the sensor sensitivity manually, we can get the different Stock AD on black mark and paper in each sensor intension. And the difference between these two values must be larger than 50 levels then printer can register the label correctly.



4.1.2.3 Continuous:

When enter the [Continuous] option, you will see following message.

Insert label ...
Then hit Enter
V

Insert media between the gap sensor and press the  button under “V” icon to start sensor calibration

Calibrate
50
+ - V

Press the  button under “+” and “-“ icon to increase and decrease Stock AD value, and press the  under “V” icon to detect sensor sensitivity.

Calibrating ...
Stock AD = 256







SUCCESSFUL
Stock AD = 50

Press the  button under “” icon to return to the next higher menu.

If “FAILED” is shown on the LCD display, please check if the media is placed between the see through type gap sensor.

FAILED
Stock AD = 50

If yes, please follow the following steps to calibrate sensor sensitivity again.

1. Press the button  under “” icon to return to “Sensor” menu.
2. Press the button  under “→]” icon to enter “Continuous” menu.
3. After insert label between the see through type gap sensor, press the button  under “V” icon to continue.
4. Press the button  under “+” icon to increase Stock AD value by 50 levels. Press the button  under “V” icon to calibrate the sensor

sensitivity.

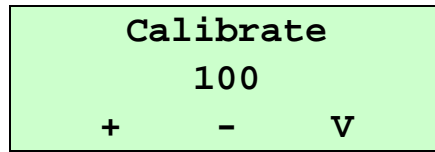

4.1.3 Serial Comm.

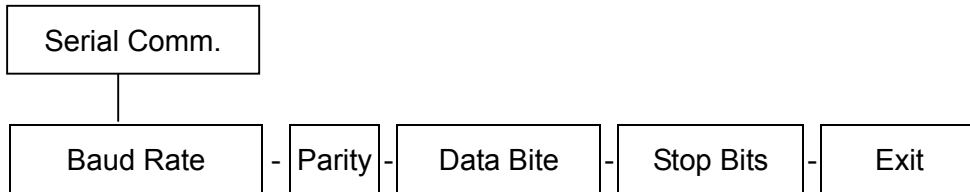

Options	Parameters	Default
Baud Rate	1200 bps/ 2400 bps/ 4800 bps/ 9600 bps / 19200 bps/ 38400 bps/ 57600 bps/ 115200 bps	9600 bps
Parity	None/ Odd/ Even	None
Data Bits	7 Data Bits/ 8 Data Bits	8 Data Bits
Stop Bits	1 Stop Bit/ 2 Stop Bits	1 Stop Bit

4.1.3.1 Baud Rate:

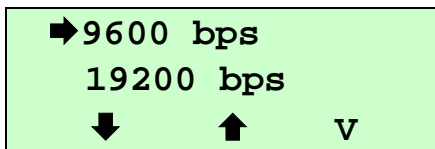





This option is used to set the RS-232 baud rate, and the default setting is 9600 bps.

Press button under ↓ and ↑ icon to select the different baud rate, and press button under “V” icon to set the value into printer. When you enter this list, the baud rate value in the right side of ➡ icon is current setting in the printer.





4.1.3.2 Parity:

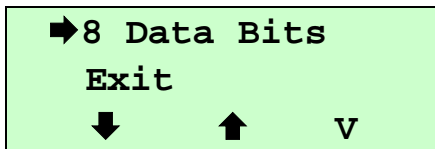

This option is used to set the RS-232 parity. The default setting is None. Press  button under  and  to select the different parity, and press  button under “V” to set the value into printer. When you enter this list, the parity in the right side of  is the printer current setting.





4.1.3.3 Data Bits:

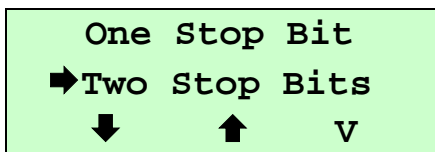

This option is used to set the RS-232 Data Bits, and the default setting is 8. Press  button under  and  icon to select the different Data Bits, and press  button under “V” icon to set the value into printer. When you enter this list, the Data Bits in the right side of  icon is the printer current setting.

4.1.3.4 Stop Bits:



This option is used to set the RS-232 Stop Bits. The default setting is 1. Press  button under  and  icon to select the different Stop Bits, and press  button under “V” icon to set the value into printer. When you enter this list, the option in the right side of  icon is the printer current setting.

4.1.4 RF Network (Optional)

Use this menu to configure optional 802.11b WiFi configuration. Checking the printer's WiFi module status, configure the RF network settings, and reset the WiFi module.

Note:

Before using WiFi module, please set the RS-232 baud rate to 19200 bps.

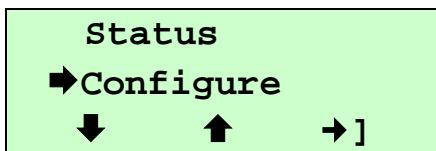
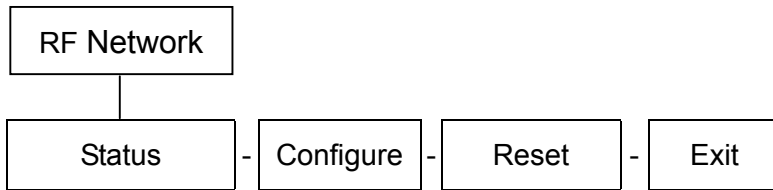

Press button under and icon to select the different options, and press button under “]” icon to enter the option.

4.1.4.1 Status: (Checking the Status)

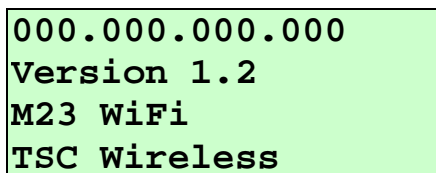

The WiFi module local IP Address, firmware version, printer mode, board version, and device name are displayed.

Press any button

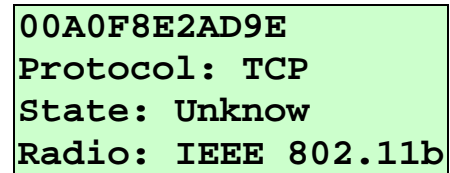



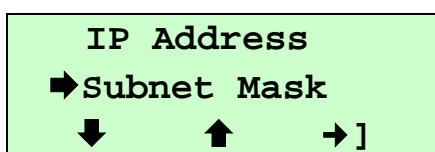

The MAC Address, Protocol, current state, and radio type are displayed. Press any to return to the RF Network menu.

4.1.4.2 Configure:





Use this menu to set the printer's IP Address, Subnet Mask, Gateway, Power Mode, Protocol, SSID and Escape character.

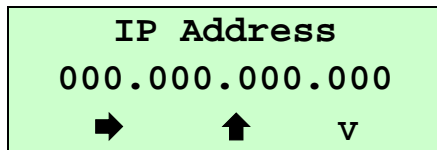

Press  button under  and  icon to select the different options, and press  button under “]” icon to enter the option.





4.1.4.2.1 IP Address

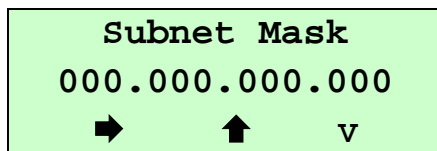

Press the  button under  icon to move the cursor from left to right, and press the  button to set the value from “0” to “9”. Press the  button under “V” icon to save the setting and return the Configure menu.





4.1.4.2.2 Subnet Mask

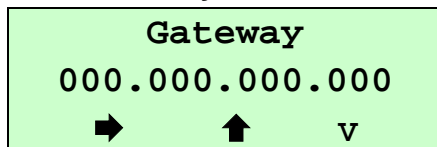

Press the  button under  icon to move the cursor from left to right, and press the  button to set the value from “0” to “9”. Press the  button under “V” icon to save the setting and return the Configure menu.





4.1.4.2.3 Gateway

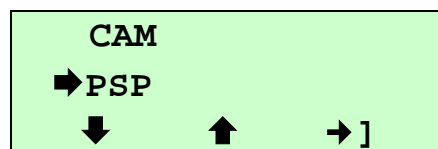

Press the  button under  icon to move the cursor from left to right, and press the  button to set the value from “0” to “9”. Press the  button under “V” icon to save the setting and return the Configure menu.

4.1.4.2.4 Power Mode



Press  button under  and  icon to select the different modes, and press  button under “]” icon to set it. CAM is Continuous Awake Mode. PSP is Power Save Protocol. PSP conserves battery power. CAM means the printer is continuously receiving and transmitting data. This

mode uses battery power quickly. If you select PSP, you are prompted to enter a PSP algorithm between 1~5. 1 is the shortest sleep time (uses battery power quicker, but responds faster); 5 is the longest sleep time (optimal battery conservation, but responds slower).

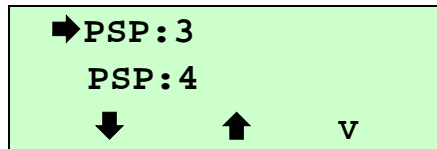

Press button under ↓ and ↑ icon to select the different modes, and press button under “v” icon to set it.

4.1.4.2.5 Protocol

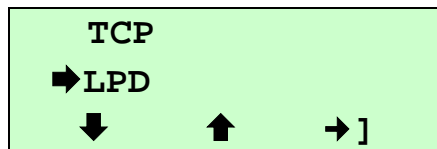

Press button under ↓ and ↑ icon to select the different modes, and press button under “→]” icon to set it. If you select TCP, you need to specify the port number for the raw printer port.

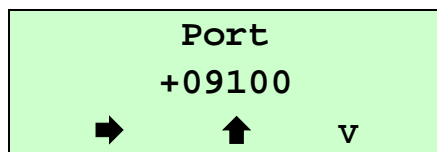

Press the button under ➡ icon to move the cursor from left to right, and press the button to set the value from “+” to “-” and “0” to “9”. Press the button under “v” icon to save the setting and return the TCP menu.

4.1.4.2.6 SSID

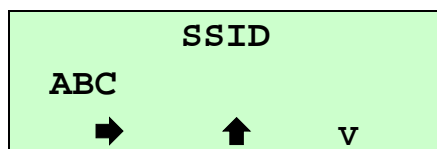

Use this option to set the SSID. The SSID is case-sensitive.



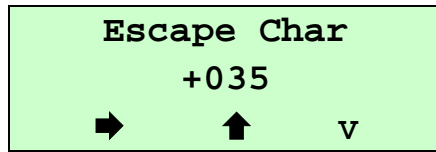

Press the button under ➡ icon to move the cursor from left space to right space, and press the button under ↑ icon to set the value.

Press the button under “v” icon to save the setting and return the Configure menu.

4.1.4.2.7 Escape Char





Use this option to set or view the Command Escape Character (CEC). Run-time messages from the radio begin with the CEC and the default is the pound sign (#), which has a decimal value of 035. You may need to change the default CEC character if it conflicts with other data, because unexpected operation could occur. The range is a decimal value between 1 and 255.

Press the  button under  icon to move the cursor from left to right, and press the  button to set the value. Press the  button under “V” icon to save the setting and return the Configure menu.

4.1.4.2.8 Exit

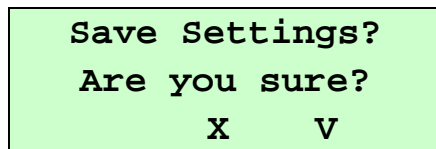
When you select “Exit” after configuring, you see



To save all the configuration settings, press the  button under “V” icon. To exit without saving the configuration settings, press the  button under “X” icon.

4.1.4.3 Reset:

After saving the configuration, please reset the 802.11b WiFi module before the changes take effect. This option is used to reset the wireless print server by cycling the power off and then back on.

You may lose your current connection and application. Resetting the network may take up to one minute before you can access the wireless print server (radio).

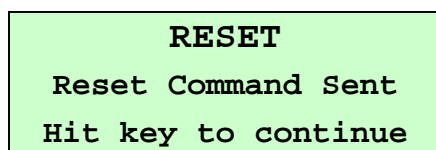

Press any  button to return the RF Network menu. The RF Network printer is ready to use.

4.1.5 Bluetooth (Optional)

Use this menu to enable or disable Bluetooth security, change the PIN, modify the local name, and to show the Bluetooth information. For move Information, please refer to section 2.5 & 5.2.

Note:

Before using Bluetooth dongle, please set the RS-232 baud rate to 115200 bps.

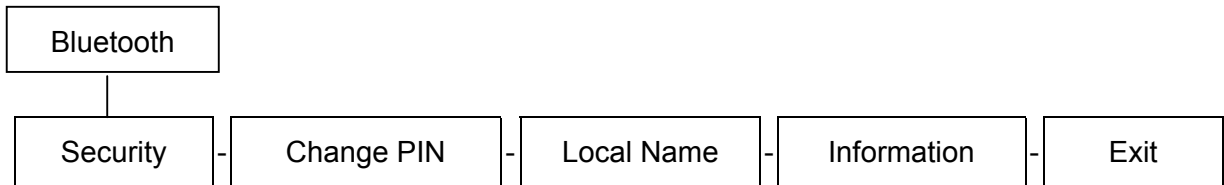

The following defaults are set in the Bluetooth printer.

Function	Default
Security	Disable
PIN	0000
Local Name	BT23

4.1.5.1 Security:

Use this option to enable or disable Bluetooth security.

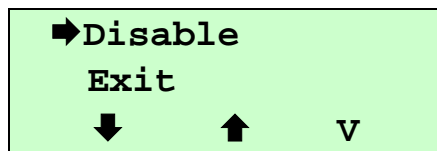





Press button under and icon to select the different modes, and press button under “v” icon to set it. If security is enabled, you need to set a PIN. See “Change PIN”, for more information.

4.1.5.2 Change PIN:

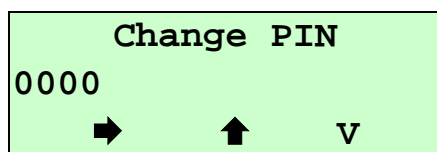
Use this option to set the Bluetooth PIN. The PIN can be up to 15 characters: 0~9. Even though a space character is displayed while you scroll through the values, the PIN cannot contain a space.

If security is enabled, you need to set a PIN. If security is disabled, you do not need to set a PIN.





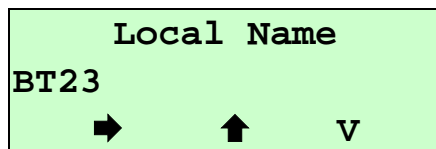

Press the  button under  icon to move the cursor from left to right, and press the  button to set the value. Press the  button under “V” icon to save the setting.

4.1.5.3 Local Name:

Use this option to view and set the Bluetooth local name. The local name is used for identification purposes with host, not authentication.



Press the  button under  icon to move the cursor from left to right, and press the  button to set the value. Press the  button under “V” icon to save the setting.

4.1.5.4 Information:

Use this option to view the Bluetooth information. Press any  button to return Bluetooth menu.

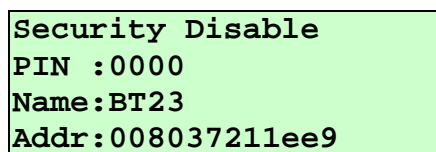

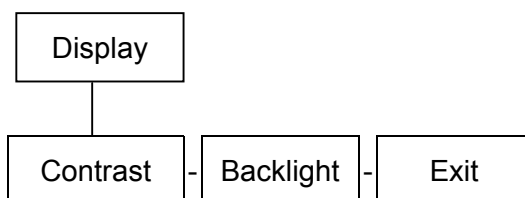

4.1.6 Display

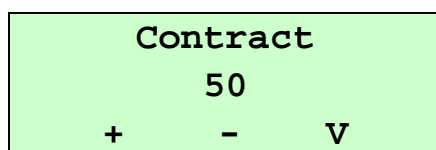

4.1.6.1 Contrast:

Adjust the LCD display contrast. The adjustable range is between 0~100. It's depending on your viewing angle. Printer default setting is 50.



Press  button under “+” icon to raise the contrast, and “-” icon to lower it, and “V” icon to set it into printer.

4.1.6.2 Backlight:

Use this option to disable or enable the LCD backlight. Printer default setting is Disable.

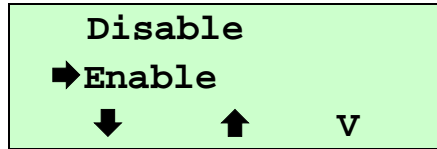

Press button under ↓ and ↑ icon to select the different modes, and press button under “V” icon to set it.

4.1.7 Power Manager (Low Power, Shut Down)

Use this menu to set the amount of time before the printer goes into sleep mode.

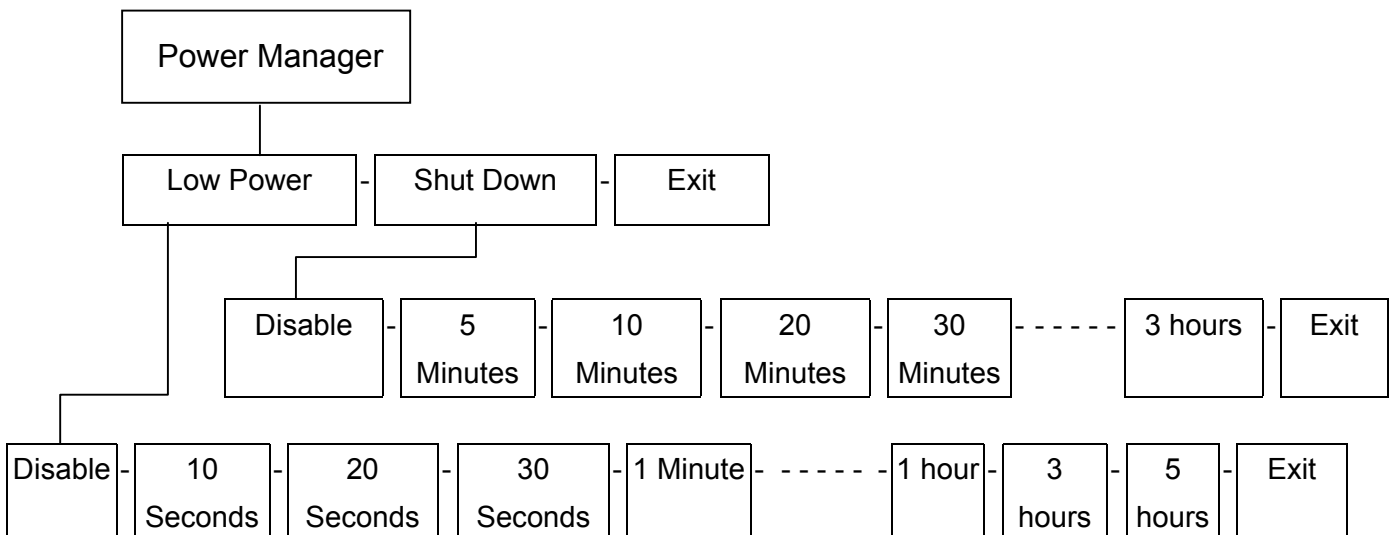

4.1.7.1 Low Power:

When the printer is inactive for a certain period of time, it goes into low power mode to conserve battery power. (You can set the printer to go into this mode from 10 seconds up to 5 hours.) During low power mode, the printer is not operational. The operator must press any button or send data through RS-232 interface except the power button to wake up the printer.

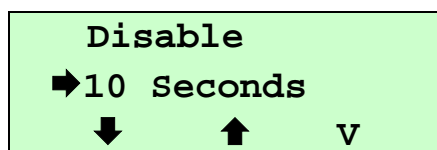



Press button under ↓ and ↑ icon to select the different modes, and

press  button under “V” icon to set it.

4.1.7.2 Shut Down:

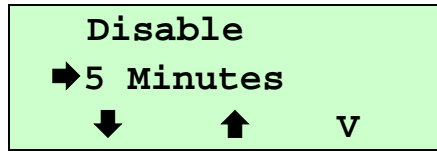
When the printer is inactive for a certain period of time, it goes into shut down. You can set the printer to go this mode from 5 minutes up to 3 hours.



Press  button under ↓ and ↑ icon to select the different modes, and press  button under “V” icon to set it.

4.2 File Manager

Use this menu to check the printer available memory and file list.

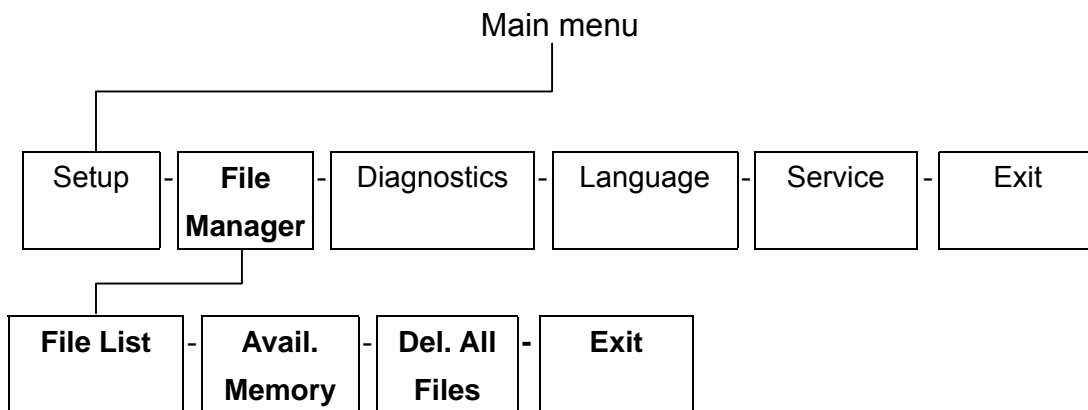

4.2.1 File List

Use this menu to show and run the files that are saved in printer flash memory.

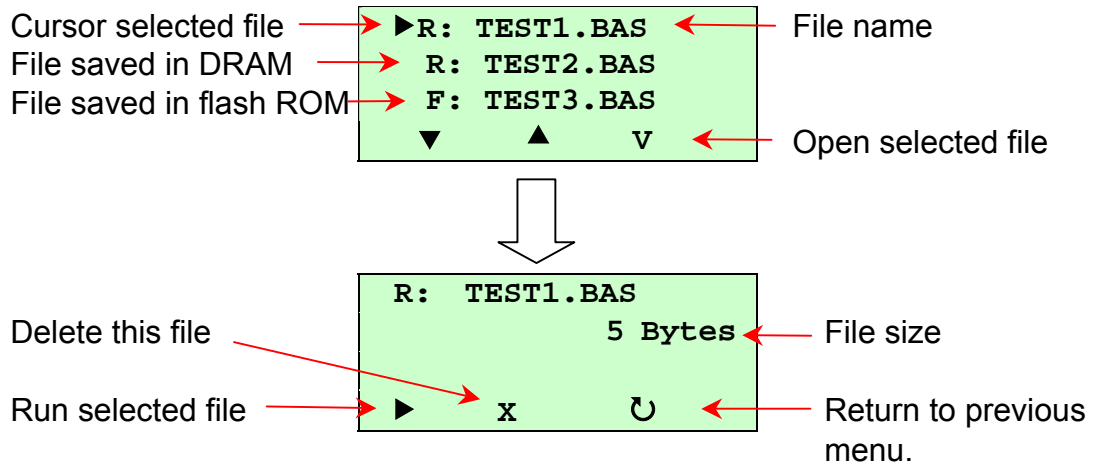

4.2.2 Avail. Memory

Use this menu to show available memory space.

```

DRAM: 256 KB Free
FLASH: 3072 KB Free
    ↻
  
```

4.2.3 Del. All Files

Use this menu to delete all files.

4.3 Diagnostics

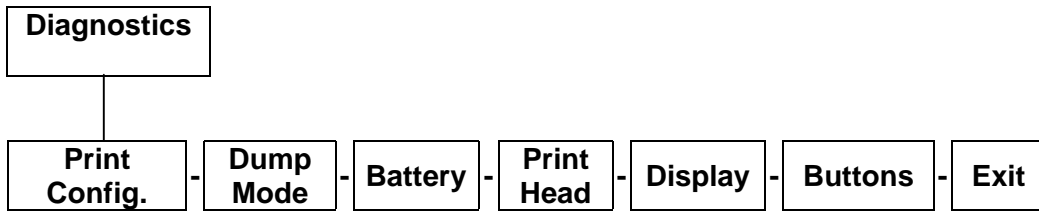

4.3.1 Print Config.

To print out the self test data to a label.

<pre> PRINTER INFO. [Checkered Pattern] MODEL: M23 MAIN VERSION: V0.90 MAIN CHECKSUM: 12BF , 740B , 0 AUX. VERSION: V0.27 AUX. CHECKSUM: B546 VOLTAGE (V): 7.52 TEMPERATURE (deg) : 27 RESISTANCE (ohm) : 170 BAD DOTS (dot) : 0 MILAGE (m) : 1 SERIAL PORT : 9600 , N , 8 , 1 CODE PAGE : 850 COUNTRY CODE: 001 SPEED: 2.0 DENSITY: 7 SIZE: 2.84 , 1.97 GAP: 0.12 , 0.00 TRANSPARENCE: 154 LOW POWER (sec): OFF SHUT DOWN (min): OFF ***** DRAM FILE: 0 FILE(S) FLASH FILE: 2 FILE(S) SECTOR SIZE: 1 KB TEST3.BAS TEST4.DAT TOTAL DRAM: 256 KBYTES AVAIL.DRAM: 256 KBYTES TOTAL FLASH: 3072 KBYTES AVAIL.FLASH: 3070 KBYTES ***** </pre>		<p>Print head test pattern</p> <p>Printer model name</p> <p>Main board firmware version</p> <p>Main board firmware checksum</p> <p>Second processor firmware version</p> <p>Second processor firmware checksum</p> <p>Battery voltage</p> <p>Print head temperature</p> <p>Print head average resistance</p> <p>Bad dots of print head</p> <p>Printed mileage</p> <p>Serial port setting</p> <p>Code page</p> <p>Country code</p> <p>Print speed</p> <p>Print darkness</p> <p>Label size (width, height)</p> <p>Gap size (vertical gap, offset)</p> <p>Sensor sensitivity</p> <p>Low power setting</p> <p>Shut down setting</p> <p>File management information</p>
--	--	--

4.3.2 Dump Mode

Captures the data from the communications port and prints out the data received by printer.

```
DOWNLOA 0D 0A 44 4F 57 4E 4C 4F 4I
D "TEST2. 44 20 22 54 45 53 54 32 2E
DAT",5,CL 44 41 54 22 2C 35 2C 43 4C
S DOWNLO 53 0D 0A 44 4F 57 4E 4C 4F
AD F,"TES 41 44 20 46 2C 22 54 45 53
T4.DAT",5 54 34 2E 44 41 54 22 2C 35
,CLS DOW 2C 43 4C 53 0D 0A 44 4F 57
NLOAD "TE 4E 4C 4F 41 44 20 22 54 45
ST2.DAT", 53 54 32 2E 44 41 54 22 2C
5,CLS DO 35 2C 43 4C 53 0D 0A 44 4F
WNLOAD F, 57 4E 4C 4F 41 44 20 46 2C
"TEST4.DA 22 54 45 53 54 34 2E 44 41
T",5,CLS 54 22 2C 35 2C 43 4C 53 0D
DOWNLOAD 0A 44 4F 57 4E 4C 4F 41 44
"TEST2.D 20 22 54 45 53 54 32 2E 44
AT",5,CLS 41 54 22 2C 35 2C 43 4C 53
DOWNLOA 0D 0A 44 4F 57 4E 4C 4F 4I
D F,"TEST 44 20 46 2C 22 54 45 53 54
4.DAT",5, 34 2E 44 41 54 22 2C 35 2C
CLS      43 4C 53 0D 0A
```

ASCII Data

Hexadecimal data related to left column of ASCII data

4.3.3 Battery

This option is used to check the battery voltage.

```
Battery
Voltage = 7.33 V
↻
```

4.3.4 Print Head

Use this option to check the print head for bad dots, view the print head dot resistance, and the print head temperature.

```
Bad Dots = 0
Resistance = 172
Temperature =32
↻
```

4.3.5 Display

To see the backlight is working or if pixels are missing on the display.

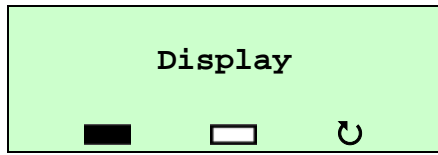

Press the button under to check if there is any white dot on the LCD. The LCD will turn to black, and press any button to return to Display menu.

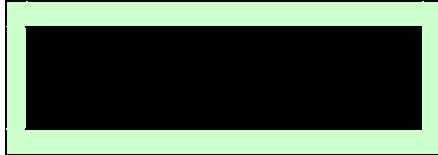

Press the button under to check if there is any black dot on the LCD. The LCD will turn to blank, and press any button to return to Display menu.



4.3.6 Buttons

To check if the buttons on the keypad are working properly.

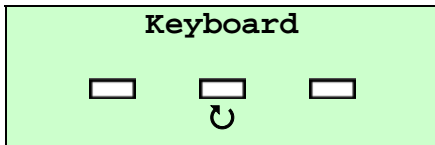

Press the button under the to check if the button is working fine. And press the button to return to Buttons menu.

The button under	Function						
<table border="1"> <tr> <td></td> <td></td> <td></td> </tr> <tr> <td>V</td> <td></td> <td></td> </tr> </table>				V			
V							
<table border="1"> <tr> <td></td> <td></td> <td></td> </tr> <tr> <td></td> <td>V</td> <td></td> </tr> </table>					V		
	V						
<table border="1"> <tr> <td></td> <td></td> <td></td> </tr> <tr> <td></td> <td></td> <td>V</td> </tr> </table>						V	
		V					

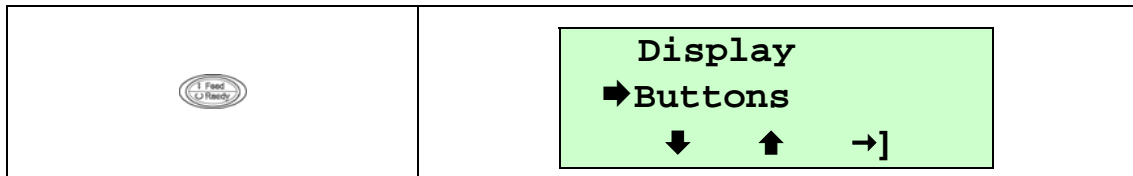

4.4 Language

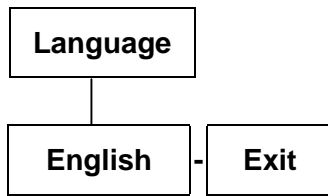

This option is used to setup LCD display interface language.

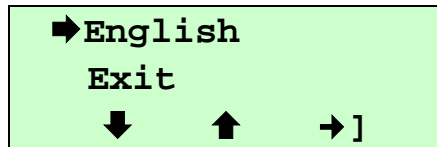

4.5 Service

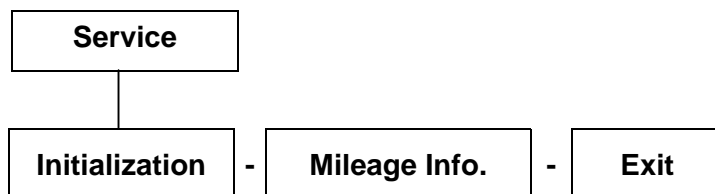

This option is used to restore printer settings to defaults and display printer mileage information

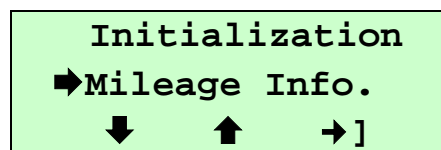

4.5.1 Initialization

The printer settings are restore to defaults as below once printer is initialized.

Parameter	Default setting
Speed	50mm/sec (2 ips)
Density	7
Label Width	2.83"(72.0mm)
Label Height	2.5"(63.4mm)
Sensor Type	Gap sensor
Gap Setting	0.12"(3.0mm)
Print Direction	0
Reference Point	0,0(upper left corner)
Offset	0
Tear Mode	On
Peel off Mode	Off
Serial Port Settings	9600 bps, none parity, 8 data bits, 1 stop bit
Code Page	850
Country Code	001
Clear Flash Memory	No
Shift	0
Gap Intension	Will be reset. Need to re-calibrate the gap

	sensor
Bline Intension	Will be reset. Need to re-calibrate the bline sensor
LCD Contrast	50
Back Light off Time	10 sec
Low Power Time	Off
Shut Down Time	Off

Note : *When printer initialization is done, please calibrate the gap or black mark sensor again.*

4.5.2 Mileage Info.

Use this option to check the printed mileage (displayed in meter).

Mileage:	6 (m)
Labels:	53 (pcs.)
	↻

5. Printing Labels

5.1 Connect with a Cable to Print

1. Install the provided printer driver and labeling software to the Windows operating system.
2. Connect the printer to a computer mainframe with RS-232 or USB cable. (Please to refer the section 2.4.)
3. Turn on the printer by pressing and holding the  button until the display turns on, then you will see:

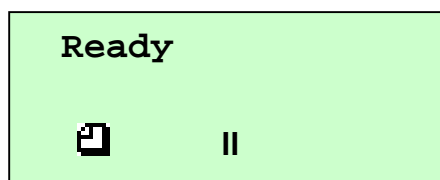

4. Loading and calibrate supplies.
5. Print Labels.

5.2 Connect by Radio (Optional)

Bluetooth

1. Please to refer the section 2.5. to connect the bluetooth.
2. Turn on the printer by pressing and holding the  button until the display turns on. The display flashes printer version information, battery charging status, and then you will see:

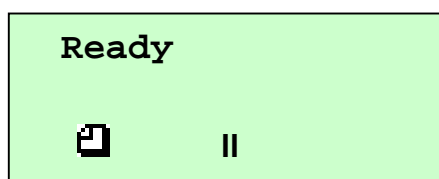

3. Loading and calibrate supplies.
4. Then, refer as follow to calibrate the bluetooth.
 - (1) Please to refer the section 2.5 to plug the Bluetooth device into the printer. Make sure the +5V/DTR switch is setting to the +5V position.
 - (2) Please to refer the section 4.1 to make sure the communication values are set to **115200, None, 8, 1**. See option " Serial Comm."
 - (3) Please to refer the section 4.1 to enable or disable Bluetooth security, change the PIN, modify the local name, and to show the Bluetooth information.

5. Print Labels.

RF Network

1. Please to connect the RF network into the RS232 port.
2. Turn on the printer and Loading and calibrate supplies.
3. Please to refer the section 4.1 to make sure the communication values are set to **19200, None, 8, 1**. See option " Serial Comm."
4. Print Labels.

5.3 Stand-alone Printing

Before Stand-alone :(Download the Format)

1. Turn on the computer and install the driver & software.
2. Connect the printer to a computer mainframe with RS-232 or USB cable.
3. Turn on the printer by pressing and holding the  button until the display turns on. The display flashes printer version information, battery charging status, and then you will see:

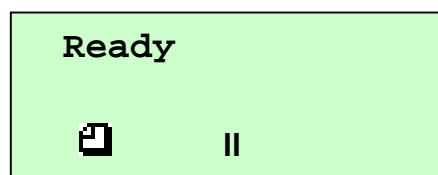

- Download a format and batch. Refer the Programmer's manual. (Can be downloaded from service and support web site.)

Start Stand-alone Printing:

- Pull out the connecting cable.
- To print the supplies (Refer the Programmer's manual.)
- Remove the printed supplies.

6. Troubleshooting

The following guide lists the most common problems that may be encountered when operating this bar code printer. If the printer still does not function after all suggested solutions have been invoked, please contact the Customer Service Department of your purchased reseller or distributor for assistance.

Problem	Possible Cause	Recovery Procedure
No Power	Check if battery is installed properly.	Reinstall the battery
	Check battery voltage meter if battery is low.	Recharge or replace battery if necessary.
Not Printing	Make sure if battery is fully charged.	Recharge/replace a battery.
	Check if front door is closed completely.	Close front door completely.
	Check if cable is well connected to serial or USB interface.	Re-connect cable to interface.
	Check if wireless settings are set correctly.	Reconfigure the wireless settings.
No Paper	Run out of label.	Supply a new label roll.
	The label is installed incorrectly.	Please refer to the steps in user's manual to reinstall the label roll.
	Gap/black mark sensor is not calibrated.	Calibrate the gap/black mark sensor.

Poor Print Quality	Make sure the battery is fully charged	Recharge or replace a new battery
	Check if front door is closed completely	Close front door completely
	Check if supply is loaded correctly	Reload the supply
	Check for dust or adhesive accumulation on the print head.	Clean the print head
	Check if print density is set properly.	Adjust the print density and print speed.
	Check print head test pattern to determine if head element is damaged	Run printer self-test and check the print head test pattern if there is dot missing in the pattern
Paper Jam	Gap/black mark sensor is not set properly	Calibrate the gap/black mark sensor
	Make sure label size is set properly.	Set label size correctly
	Labels may be stuck inside the printer mechanism.	Remove the stuck label.
	The serial port setting is not consistent between host and printer.	Please reset the serial port setting.
	The serial port cable pin configuration is not correct.	Please replace the null modem cable
Reduced Battery life	Check battery date code, if battery is one to two years old, short life may be due to normal aging.	Replace a battery.

7. Maintenance

This session presents the clean tools and methods to maintain your printer.

1. Please use one of following material to clean the printer.

- Cotton swab
- Lint-free cloth
- Vacuum
- 100% ethanol

2. The cleaning process is described as following

Printer Part	Method	Interval
Print Head	<ol style="list-style-type: none"> 1. Always turn off the printer before cleaning the print head. 2. Allow the printhead to cool for a minimum of one minute. 3. Use a cotton swab and 100% ethanol to clean the print head surface. 	Clean the print head when changing a new label roll
Platen Roller	<ol style="list-style-type: none"> 1. Turn the power off. 2. Rotate the platen roller and wipe it thoroughly with 100% ethanol and a cotton swab, or lint-free cloth. 	Clean the platen roller when changing a new label roll
Peel Roller	<ol style="list-style-type: none"> 1. Turn the power off. 2. Rotate the Peel-off roller and wipe it thoroughly with 100% ethanol and a cotton swab, or lint-free cloth. 	Clean the peel roller when changing a new label roll
Tear Bar/Peel Bar	Use the lint-free cloth with 100% ethanol to wipe it.	As needed
Sensor	Compressed air or vacuum	Monthly
Exterior	Wipe it with water-dampened cloth	As needed
Interior	Brush or vacuum	As needed

3. Illustration for recommended cleaning parts:

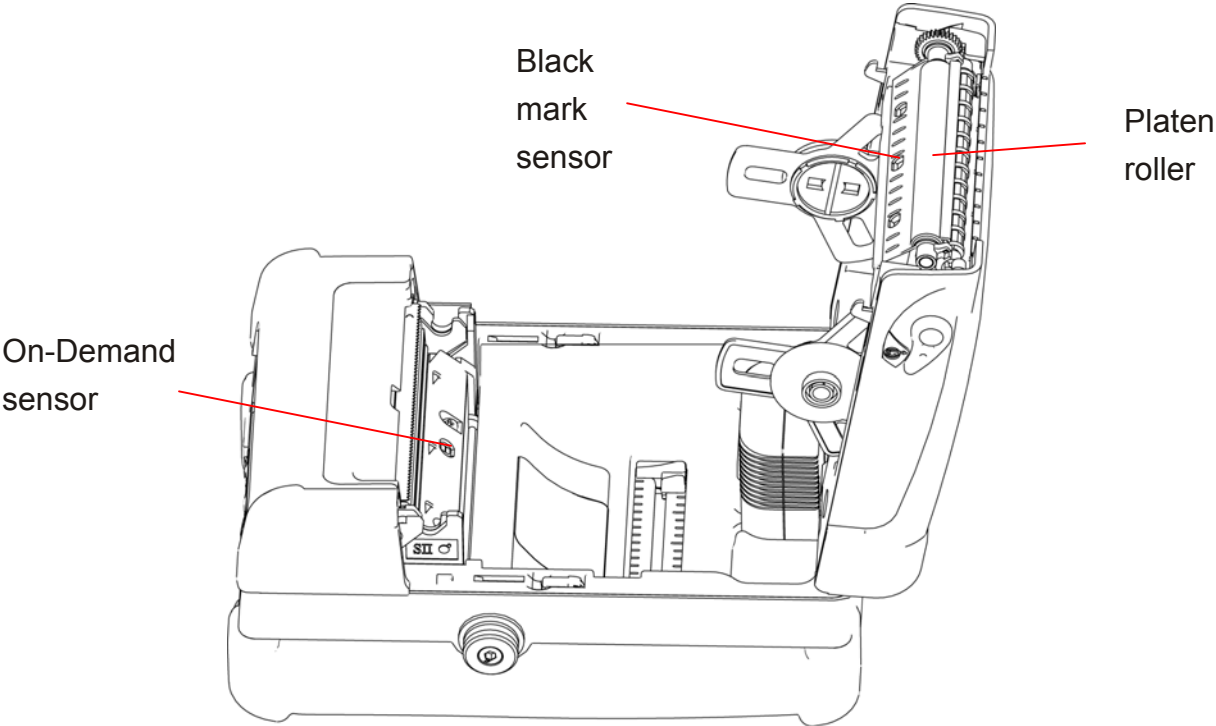
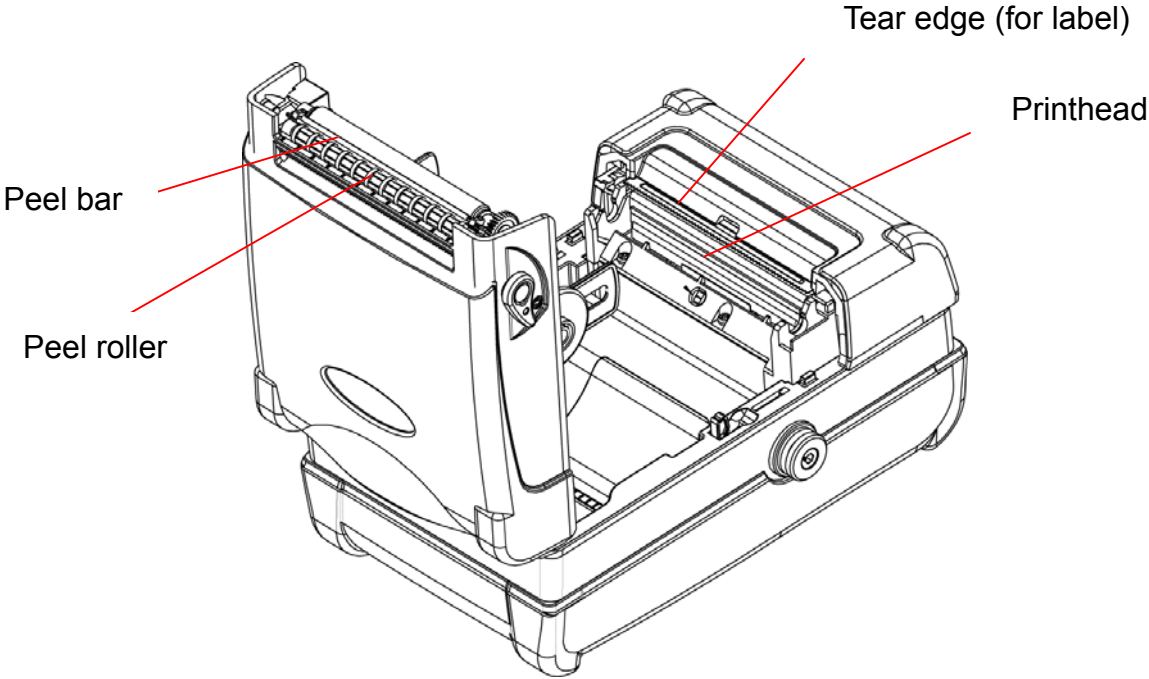

Note:

- Do not touch printer head by hand. If you touch it carelessly, please use ethanol to clean it.
- It's industry alcohol. Please do not use regular alcohol, which may damage the printer head.
- You may have to clean the supply sensors more often if you frequently receive supply error messages.

8. Firmware Update Procedure

Both RS-232 and USB interfaces are available to upgrade printer firmware. Please refer to the firmware update procedures as below.

8.1 Update Firmware Via Serial Port

1. Set M23's "Serial Comm." setting as below.

Baud Rate = 115200

Parity = No Parity

Data Bits = 8 Data Bits

Stop Bits = 1 Stop Bits

2. Printer is in ready mode.

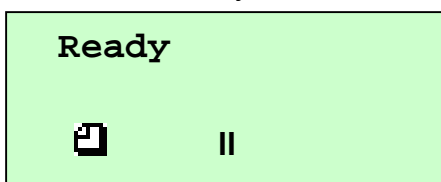

Method 1 : In MS-DOS mode (Command Prompt), copy the firmware file (*.NEW) to printer via serial port.

- (1) Set the PC's COM port setting.

Please issue following command in command prompt mode to setup PC RS-232 communication parameters.

```
C:\>mode com1 baud=115200 parity=n data=8 stop=1 octs=on rts=on <Enter>
```

```
Command Prompt
C:\>mode com1 baud=115200 parity=n data=8 stop=1 octs=on rts=on

Status for device COM1:
-----
Baud:          115200
Parity:        None
Data Bits:     8
Stop Bits:     1
Timeout:       ON
XON/XOFF:      OFF
CTS handshaking: ON
DSR handshaking: OFF
DSR sensitivity: OFF
DTR circuit:   HANDSHAKE
RTS circuit:   ON

C:\>
```

- (2) Copy firmware file to M23 with binary copy parameter.

```
C:\>copy M23_v06.NEW /b com1
```

```

C:\M23>dir
Volume in drive C has no label.
Volume Serial Number is 540B-1E68

Directory of C:\M23

06/10/2005  01:14 PM  <DIR>          -
06/10/2005  01:14 PM  <DIR>          ..
03/10/2005  11:17 AM           983,077 M23_v06.NEW
               1 File(s)        983,077 bytes
               2 Dir(s)  26,000,412,672 bytes free

C:\M23>copy m23_v06.new /b com1
1 file(s) copied.

C:\M23>

```

(3) M23 will show the following message on LCD when firmware update.

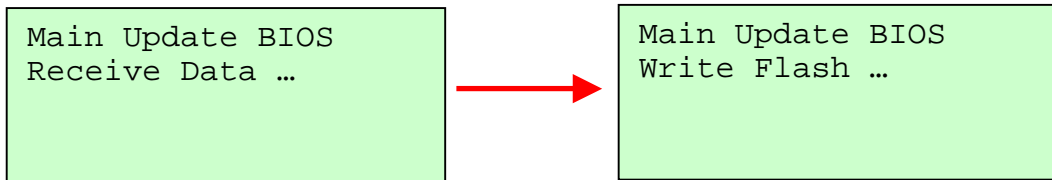

(4) Printer will reset automatically when firmware is upgrade completely.

Method 2 : Use the utility “CommTool.exe” to update printer firmware

(1) Start “CommTool” utility and click “RS232 setup” button to setup PC RS-232 communication parameters.

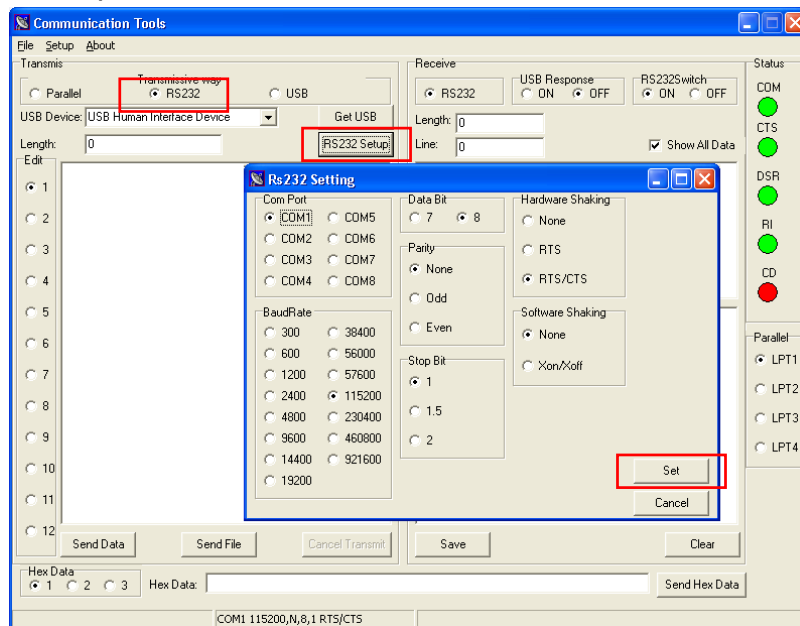

(2) Click “Send File” button and select firmware file to upgrade firmware from RS-232 interface.

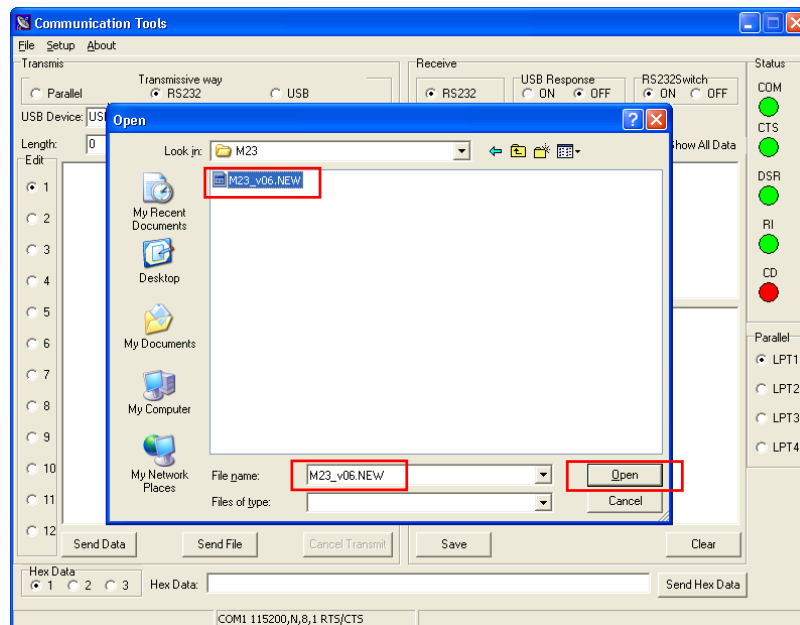

(3) Printer will reset automatically when firmware update is completed.

8.2 Update Firmware Via USB Port

- 1. Select USB port and click "Get USB" button.
- 2. Select "USB Printing Support" in USB Device option

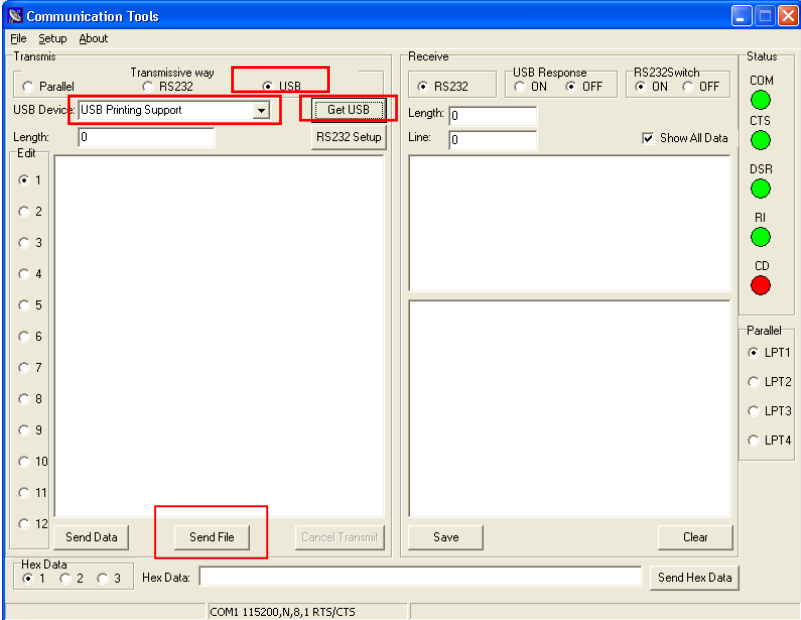

3. Click "Send File" button to select firmware file and send selected firmware through USB interface to update printer firmware.

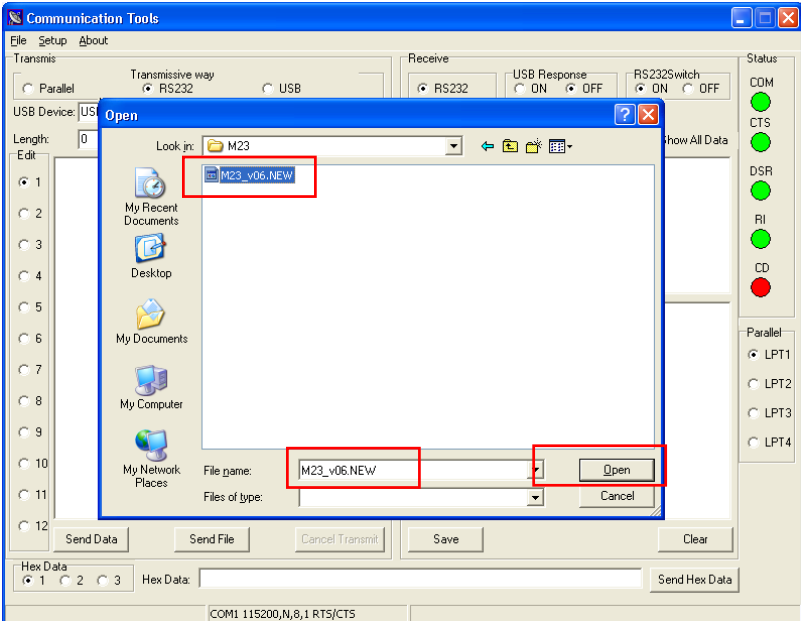

4. M23 will show the following message on LCD when firmware update.

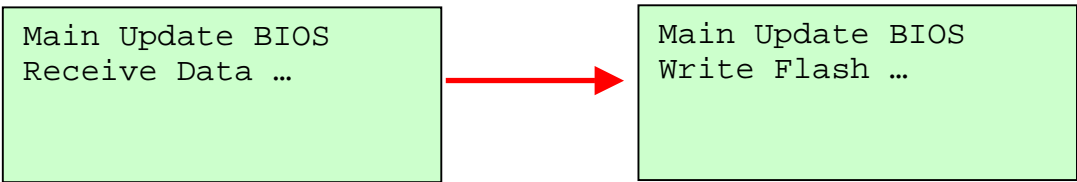

5. Printer will reset automatically once firmware upgrade is completed.

9. Power on utilities

There are two power-on utilities to set up and test printer hardware. These utilities are activated by pressing button and by turning on the printer power simultaneously. The utilities are listed as below:

1. Printer initialization
2. Ignore AUTO.BAS

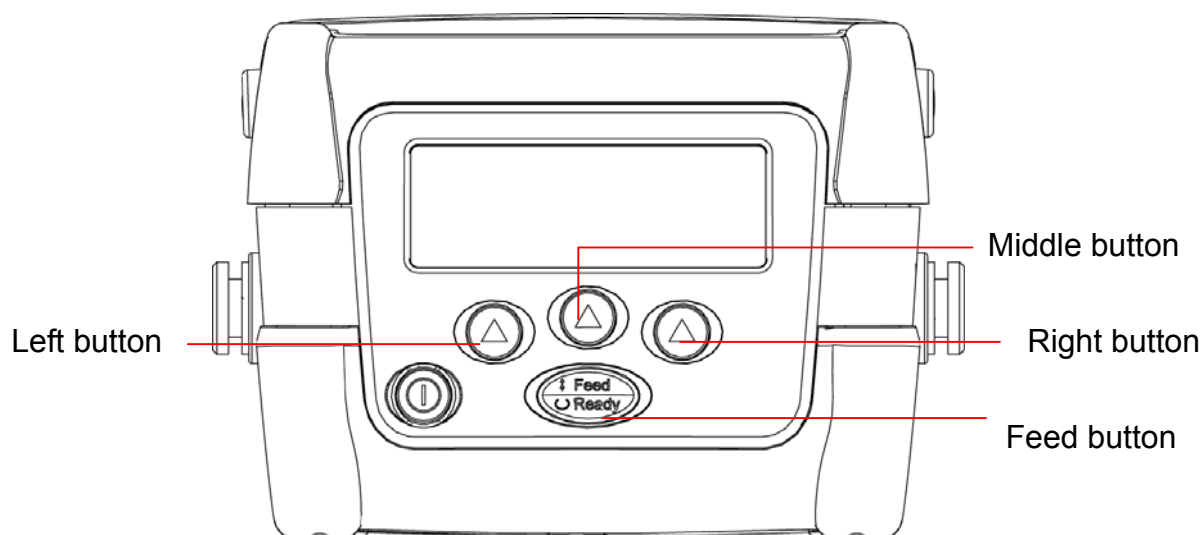

9.1 Printer initialization

Printer Initialization will restore printer settings to defaults.

Default settings are listed as below:

Parameter	Default setting
Speed	50mm/sec (2 ips)
Density	7
Label Width	2.83"(72.0mm)
Label Height	2.5"(63.4mm)
Sensor Type	Gap sensor

Gap Setting	0.12"(3.0mm)
Print Direction	0
Reference Point	0,0(upper left corner)
Offset	0
Tear Mode	On
Peel off Mode	Off
Serial Port Settings	9600 bps, none parity, 8 data bits, 1 stop bit
Code Page	850
Country Code	001
Clear Flash Memory	No
Shift	0
Gap Intension	Will be reset. Need to re-calibrate the gap sensor
Bline Intension	Will be reset. Need to re-calibrate the bline sensor
LCD Contrast	50
Back Light off Time	10 sec
Low Power Time	Off
Shut Down Time	Off

Please follow the steps below to initialize the printer.

1. Turn off the printer power.
2. Hold down the **middle** and **right** buttons and turn on the printer power.
3. Do not release the buttons until printer LCD shows "Initializing..." as below.

Initializing...

Note : *When printer initialization is done, please calibrate the gap or black mark sensor again.*

9.2 Ignore AUTO.BAS

If AUTO.BAS file is downloaded in printer flash memory, printer will run this program automatically when turns on printer power.

Please follow the steps below to skip the AUTO.BAS file.

1. Turn off the printer power.
2. Hold down the **right** button and turn on the printer power.
3. Do not release the buttons until the printer is ready then, LCD will show "IGNORE AUTO.BAS" under "Ready" in a second.

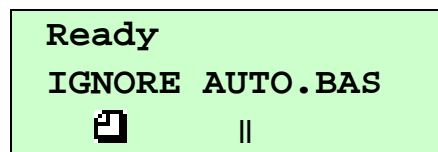

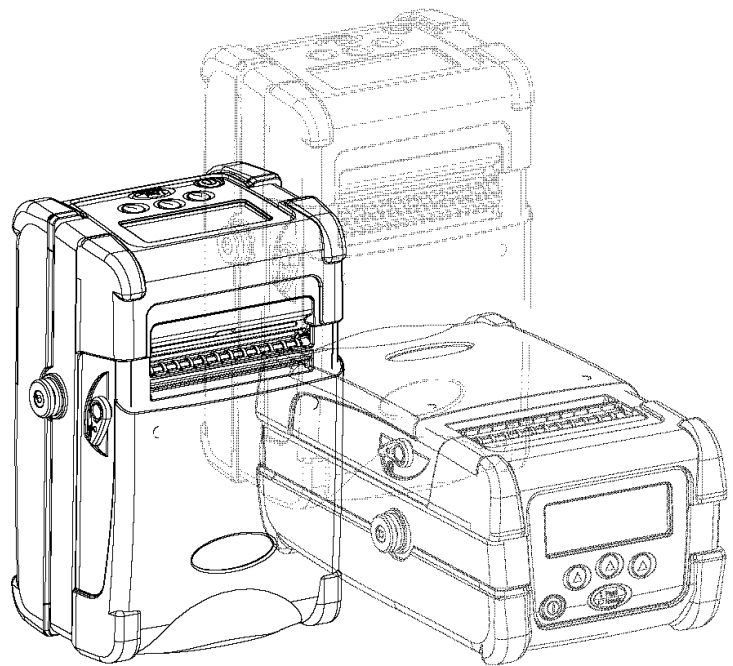

TSC Auto ID Technology Co., Ltd.

Headquarters / Factory

No. 35, Sec. 2, Ligong 1st Rd., Wujie Town
, I-Lan County 268, Taiwan, R.O.C.

TEL: +886-3-990-6677

FAX: +886-3-990-5577

Web site: www.tscprinters.com

E-mail: printer_sales@tscprinters.com

tech_support@tscprinters.com

Taipei Office

11F, No. 205, Sec. 3, Beishin Rd., Shindian City,
Taipei 231, Taiwan, R.O.C.

TEL: +886-2-8913-1308

FAX: +886-2-8913-1808