

Keyboard Controller

Users' Manual



Contents

1. Summary	3
1.1 Notice	3
1.2 Function & Characteristic	3
1.3 Technical Data	3
2. Keyboard connection	4
2.1. RS485 interfaces.....	4
2.2 Connect matrix	4
2.3 Direct connect with Dome.....	5
2.4 Keyboard connection in the System.....	5
3. Keyboard operation instruction	6
3.1 Electrify	6
3.2 LED display screen	6
3.3 Joystick controls dome	7
3.4 Rigger the aim dome	7
3.5 Dome lens control	7
3.6 Set dome function.....	7
3.6.1 Preset.....	7
3.6.2 Scan.....	7
3.6.3 Pattern.....	7
3.6.4 Cruise.....	8
3.7 Call dome main menu.....	8
3.8 Matrix Control.....	8
3.8.1 Switch dome in order.....	8
3.8.2 Call matrix main menu.....	8
3.8.3 Confirm after program.....	8
3.8.4 Change object monitor.....	8
4. Keyboard control.....	8
4.1 Keyboard parameter setup.....	9
4.1.1Keyboard ID setup.....	9
4.1.2 Keyboard baud rate setup.....	10
4.1.3 Navigation key adjust.....	10
4.1.4 Display Keyboard information	11
4.2 Dome setup.....	11
4.2.1 Pre-set setup.....	11
4.2.2 Dome Scan setup.....	12
4.2.3 Pattern setup.....	12
4.2.4 Tour setup.....	13
4.3 Protocol setup.....	14
4.4 Exit Keyboard menu.....	14
5. Appendix	14
5.1 RS485 Bus general knowledge.....	14
5.2 Keyboard shortcut instruction.....	16
6. Keyboard menu index.....	18

1. Summary

The keyboard is a universal keyboard of security monitoring series, which can control the ball-type integrated camera of all kinds protocols matrix, which has been equipped with Joystick which can control the revolving of the camera and the zoom magnification of lens; with the LCD screen and the function of back-light; which can display the current operation order the control protocol name the current dome ID the current monitor ID and the state of joysticks. The user can control the CCTV system more easily with the joystick and the LCD screen.

1.1 Notice

Please read the manual carefully and reserve it.

Please advert to the notice in manual.

Please don't place the keyboard in the moist place.

1.2 Function and Characteristic

- Rs485 Bus Line, and a keyboard can connect 31 domes at most in the direct control mode.
- can be compatible with all kinds of protocols.
- can control the Iris Focus and Zoom.
- can set and call the preset, run the scanning the pattern and the tour.
- can control the matrix and through which can control the dome indirectly.
- equipped with the 3D Joystick and a LCD screen
- The LCD can display the current operation order, the control protocol name, the current dome ID ,the current monitor ID and the state of joysticks.
- Infrared ray emission, emission the same data & content as RS485

1.3 Technical Data

★Electrical character

Input voltage: 9V-12V DC

Rating Power: 0.5W

★Communicate character

Communicate interface: RS485×1,infrared emission

Communicate frequency: 2400、4800、9600、19200bps

Communicate distance: RS485 can reach 1.2Km,infrared emission reaches 10m.

★Operational environment

Operating temperature: 0℃~50℃

Relative humidity less than 90%

★Physical property

L*W*H=168mm*136mm*105mm

Weight: 0.400 kg

2.Keyboard Connection

There is interface on the back of the keyboard, which equipped with kinds of communication Interface RS485 and infrared emission, which can connect with and control kinds of peripheral equipments.

2.1. RS485 interfaces

Rs485 interfaces are on the 2bit ribbon cable connection of the keyboard.RS485 A+ B-) can connect with the dome when the keyboard controls the dome directly;RS485 A+B-can connect with DVR or other keyboards when the keyboard controls the dome by matrix

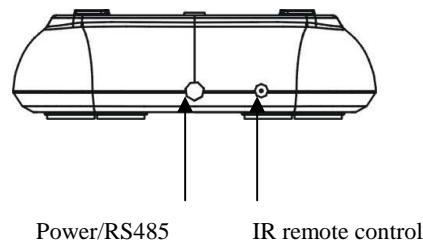

2.2 Direct connect with Dome

Keyboard connect the Dome wit RS485。 The RS485 interface of the Dome is on the commutator of the Dome.Press the metal button in the hanging frame, open the commutator, will find a 4bit power jack, follow the surface instruction to find RS485 (A+, B-) follow the instruction。 Maybe a different connect way when come from different manufacturer。

Figure 2-3.1

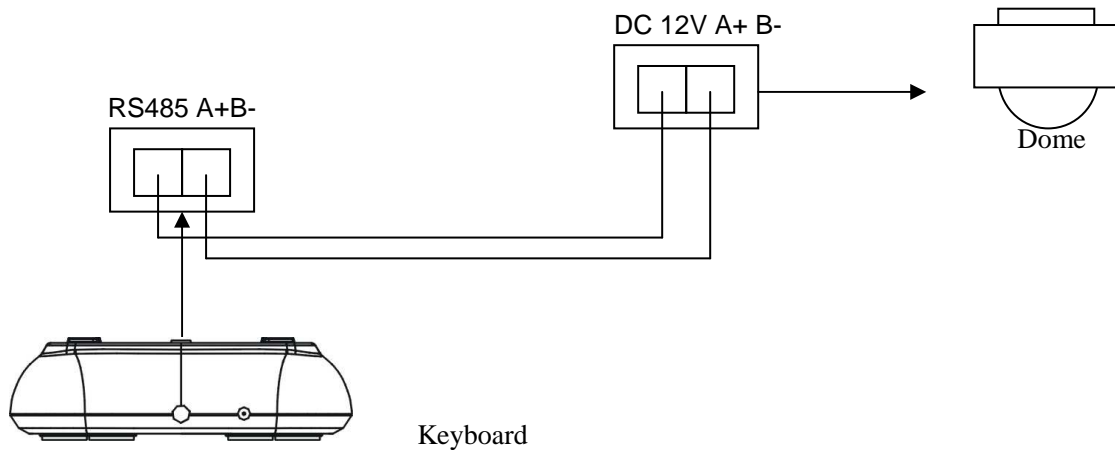

2.3 Keyboard connection in the system

Indirect control the dome when connect with matrix (as figure 2-4.1)。contrariwise will control the domes directly, Parallel connect the keyboard and dome to the bus of RS-485, all the keyboard can control any dome among them, under this way, the add of the main keyboard should be “1” and baud rate should be 9600bps (as figure 2-3.1)

Figure 2-4.1

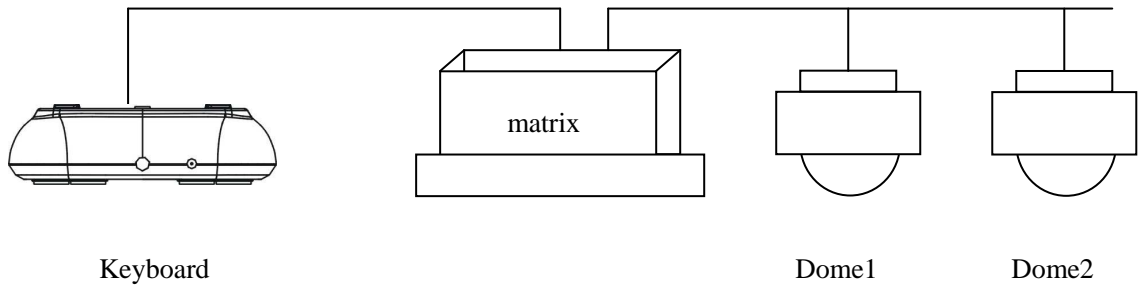

Caution

- 1、 the max quantity of master equip and be charged equip controlled by a RS485 bus is, so when use the keyboard to control direct the max dome quantity is 3
- 2、 max quantity keyboard in a system is 4,also the 4 keyboards should be different ID

Figure 2-4.2

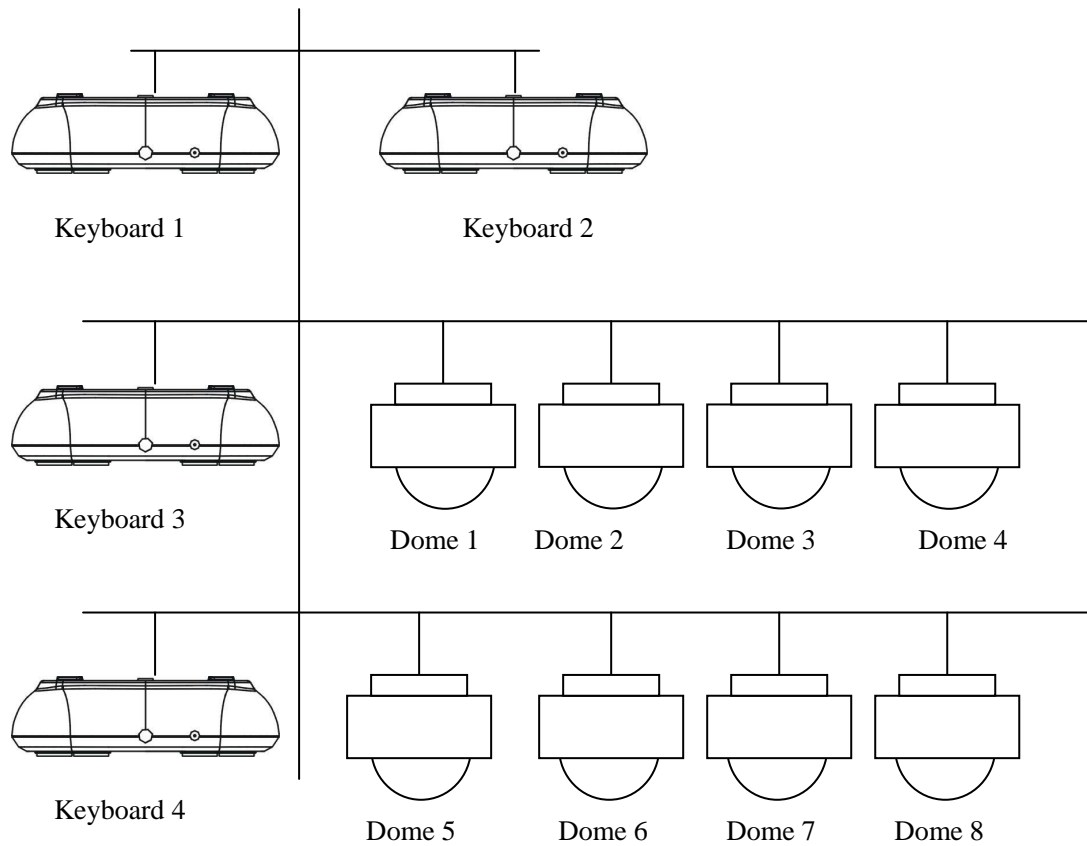

3. Keyboard operation instruction

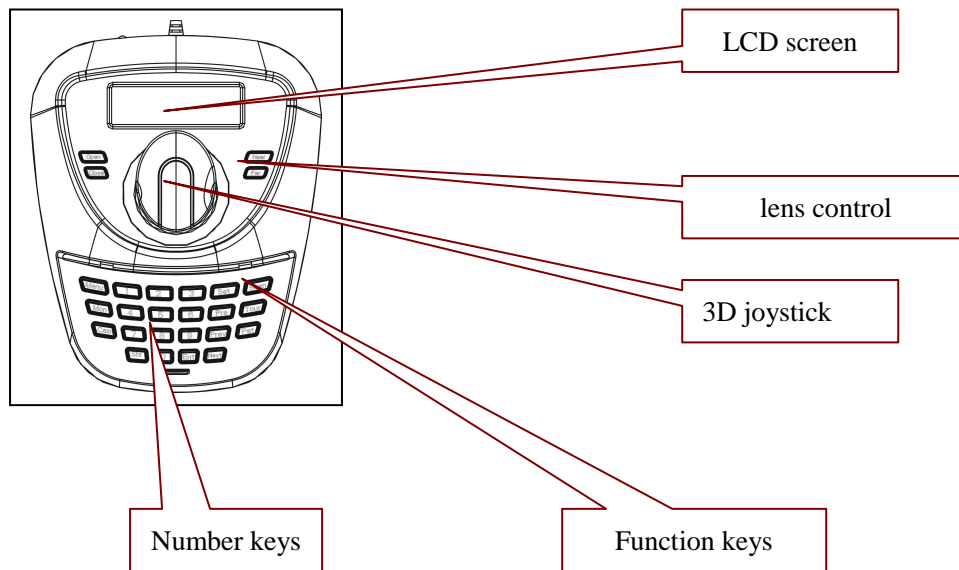

Figure 3-1.1

Attention please because different system have some different special operation ways, so should consider the actual requirement when operation in some special systems

3.1 Electrify

When the power is on, the keyboard will automatically check the baud rate、 protocol of the keyboard、 aim dome and the aim monitor, and all the info. will be displayed on LCD screen.

Attention

The joystick should be nil when keyboard is initializing

3.2 LCD display screen

LCD screen display contents: aim dome、 aim monitor and baud rate etc. And at the end of the content will show the current operation order and the states of joystick, as follows figure show .When operation, LCD back light will on, and will be off 10s after the operation.

Camera	ID: 001
Monitor	ID: 001
Protocol	: Pelco-d
Baud rate	: 2400bps



Figure 3-1.2

3.3 Joystick Controls Dome

Functions of the Joystick: Dome rotation control and Object dome menu setup.

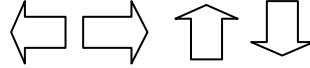
● When operate the joystick at will to any direction Dome will rotate at the same direction ,and the direction will be displayed below right corner as



When for menu setup,  for the upper menu item,  for the next menu; “” for the sub menu or

save the setup;  for un-save or exit.

● Direct proportion between the speed of the Dome and the lean angle of the navigation keys,large lean angle ,faster rotation speed.

3.4 Rigger the aim dome

【N】 + 【CAM】

【N】 for Number, input the serial number of the Dome, Press **【CAM】** key to amend the add of the aim dome.

3.5 Dome lens control

● Zoom:

Users can control the zoom by rotating the joystick

● Focus:

Press **【FAR】** key focus for far objects.

Press **【NEAR】** key focus for vicinity objects.

Normally ,Zoom and focus will be adjusted automaticly by the dome, and with the**【FAR】****【NEAR】** to realize the manual zoom and focus

● Iris:

Press **【OPEN】** key, manual Iris accretion, whole white picture means max iris

Press **【CLOSE】** key , manual Iris minish, whole black picture means min.iris

3.6 Dome function operation

3.6.1 Pre-set

Pre set: **【SET】 + 【N】 + 【PRESET】**

Adjust pre set: **【N】 + 【PRESET】**

【N】 for the number of the pre-set.

3.6.2 Scan

Left borderline: **【SET】 + 【1】 + 【SCAN】**

Right borderline: **【SET】 + 【2】 + 【SCAN】**

star: **【1】 + 【SCAN】**

Enter the menu to set when need change the scan speed.

3.6.3 Pattern

● design path setup: **【SET】 + 【N】 + 【PATTERN】 + path + 【SET】 + 0 + 【 PATTERN】**

Press **【SET】** key, input the number of design scan (1-4), press **【PATTERN】** key, enter the path setup state, when ending press **【SET】** key first, then press **【0】** key, then **【PATTERN】** key,

● starting the design scan: **【N】 + 【PATTERN】** input the design scan number (1-4), press **【PATTERN】** key to starting,

3.6.4 Cruise

starting: **【N】 + 【TOUR】 / 【TOUR】** cruise number first , then **【TOUR】** key, starting the cruise.

Direct press the **【TOUR】** key when the system only have one cruise ..

3.7 Call Dome main menu

【9】 + 【5】 + 【PRESET】: Input 95, press **【PRESET】** key, aim Dome, menu will display on the monitor.

3.8 Matrix control

3.8.1 switch dome orderly

The matrix can connect the 16pcs High Speed Dome. All the information like the Series NO, Data and time will display on the monitor while switch the speed dome camera. **【PREV】**: switch to previous camera; Press **【PREV】** 2 Sec, it will keep switch till the whole 16 high speed dome. Press **【Stop】** to stop the switching. **【NEXT】**: back forward. Press **【NEXT】** it will switch to the next camera; Press **【NEXT】** 2 Sec, it will keep back forward switch till the final 16th camera. You can use the **【Stop】** key to stop the operate

3.8.2 Call matrix main menu

【SHIFT】 + 【SET】: Call the main menu, the menu will display on the object monitor. How to use the keyboard Setting the matrix? Pls refers the matrix operate manual.

3.8.3 Confirm after program

【ENTER】: after the matrix is programmed, press **【ENTER】** , reflects confirm after program.

As for the detail program, please refer to the matrix operation manual.

3.8.4 Change object monitor

【N】 + 【MON】 Input the monitor ID, then press MON the image and the menu of the dome that you controlled by keyboard will display in the object monitor

4、Keyboard menu control

● Keyboard parameter set up

Turn on the power and press the **【MENU】** , the system information will display on the screen, like the picture(4.1-1), press again the system information will disappear. You can do all the keyboard operation while in the standby condition or the system information display condition.

Press **【MENU】** and hold on 2 sec, you will enter the main menu as the picture (4.1.1-1)show. All the menu setting need enter the main menu first,and use the correspond NO or the Joy calibrate to move UP and DOWN. While you find the item you need, move the joystick RIGHT or LEFT to enter the menu.

- | |
|---|
| <ol style="list-style-type: none">1. Keyboard setup2. Dome setup3. Protocol select4. Exit menu |
|---|

Picture 4.1-1

● Save the setting

After setting the function you need, press **【ENTER】** to save the setting. After finishing the setting, the TFT will display “Success” .

● Back to Previous menu

Press the **【PREV】** key to back to the previous menu.

4.1 Keyboard parameter setting

4.1.1 Keyboard ID set up

1、 Enter the main menu

LCD will display (picture4.1.1-1)

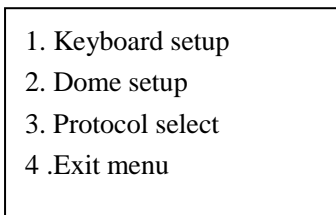

Picture4.1.1-1

2、 Press **【1】** to select the keyboard setting as LCD(Picture4.1.1-2)

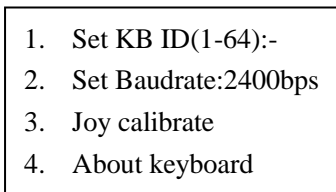

Picture 4.1.1-2

3、 Press **【1】** again will show the picture(Picture4.1.1-3)

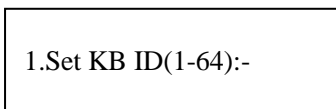

Picture4.1.1-3

4、 Press **【1】** to select the ID Setting (Picture4.1.1-4)

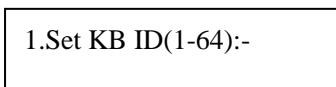

Picture 4.1.1-4

Use the "Number key" to select the camera ID in the range (1-64); And then press the **【Enter】**to save, the screen will display Success as picture(4.1.1-5).

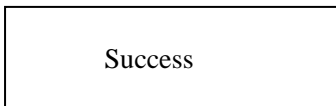

Picture4.1.1-5

If the NO you input is beyond the range1~64, it will display Error as picture (4.1.1-6) .

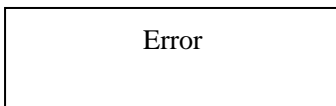

Picture 4.1.1-6

5、 Press **【PREV】** or use the shake toward to LEFT to back to previous menu.

Warning:

The camera ID default is 1. only one keyboard in a system, it must set to ID as “1”.
Several keyboards work together at most is 4 keyboards, and it must has one keyboard ID is ID1, otherwise all the keyboard can not work. And the LCD will show as picture

4.1.2 Keyboard Baud Rate Setting

Enter the main menu as the TFT picture (4.1.1-1) show..

Press **【1】** will show on the TFT as picture (4.1.1-2)

Press **【2】** select the Baud Rate setting, as Picture(4.1.2-1)

2. Set Baud rate: 2400bps (4800bps/9600bps/19200bps)

Picture 4.1.2-1

2400bps\4800bps\9600bps\19200bps is available(commonly under the IR emission mode, baud rate is 2400bps or 4800bps), You can select the Baud rate you need and press the **【ENTER】** to save. If you operate success, the screen will show “Success” .

Press **【PREV】** or move the joystick to LEFT to back to previous menu.

Warning:

If connect to the matrix, baud rate must be 9600bps. Several keyboards work together, it must use 9600bps or 19200bps

4.1.3. Joystick calibrate

When the joystick at midpoint position ,pls enter the menu to enter the “ joystick calibrate.” Item

When calibrating, the joystick must be in a natural state. Enter the main menu

LCD will display (picture4.1.1-1)

2、 Press **【1】** to select the keyboard setting as LCD(Picture4.1.1-2)

3. 2.Press **【3】** into joystick calibrate as LCD(Picture4.1.3-1)

Joystick is free
then press Enter

Picture4.1.3-1

Press **【Enter】** and the joystick calibrate is finished as LCD display (Picture4.1.3-2)

Success

Picture4.1.3-2

Attention: when calibrating the joystick, pls make sure the joystick is in the midpoint position

4.1.4 Keyboard information display

Enter the keyboard information display menu as LCD(Picture 4.1.1-2)

Press **【2】** to check the keyboard information as LCD(Picture 4.1.4-1)

4.2 Dome set up

4.2.1 Preset set up

Enter the main menu as picture (4.1.1-1) and press**【2】** to enter the dome setting menu as picture (4.2.1-1);
This part you can set the follow function: Preset, Scan, Pattern, Tour.

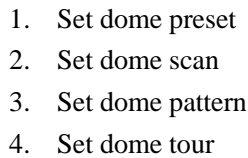
- 
1. Set dome preset
 2. Set dome scan
 3. Set dome pattern
 4. Set dome tour

Picture4.2.1-1

Press **【1】** enter the dome Preset function setting as picture (4.2.1-2)

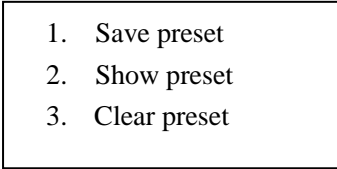
- 
1. Save preset
 2. Show preset
 3. Clear preset

Picture 4.2.1-2

Item 1 : Save preset; item 2 : Show the preset; Item 3: delete the preset

Press **【1】** enter the preset, you can input the preset NO as picture (4.2.1-3) show.

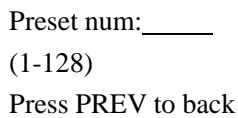

Preset num: _____
(1-128)
Press PREV to back

Picture 4.2.1-3

After enter the preset menu you can use navigate key control the dome directly, and input the preset NO to save as the picture 4.2.1-4 show. And on the TFT screen will display SUCCESS.



Success!

Picture 4.2.1-4

Press **【Prev】** back to previous men.

Warning:

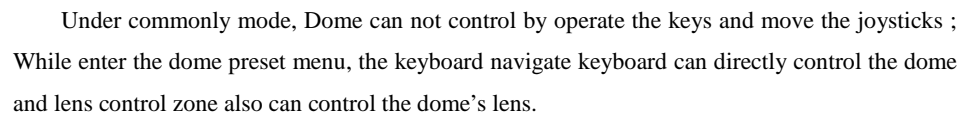

Under commonly mode, Dome can not control by operate the keys and move the joysticks ;
While enter the dome preset menu, the keyboard navigate keyboard can directly control the dome
and lens control zone also can control the dome's lens.

Press **【2】** enter the “Show the preset” menu as picture 4.2.1-5

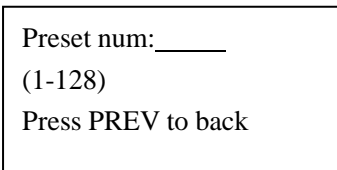

Preset num: _____
(1-128)
Press PREV to back

Picture 4.2.1-5

Input the Preset NO that want delete, and press the **【ENTER】** to call it, and the TFT will display “Success” .
Use the navigate
Key or **【PREV】** back to previous menu. Press **【3】** enter the “clear the Preset” to clear preset information as picture 4.2.1-6 show.

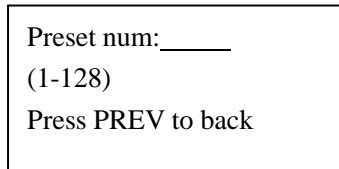

Picture 4.2.1-6

Input the PRESET NO which you want to clear, and press the Enter to clear it, and it will show “Success” and back to previous menu.

4.2.2 Dome Scan set up

Enter the menu (4.1.1-1)

Press **【2】** enter the dome setting menu as the picture (4.2.1-1);

Press **【2】** again to enter the dome scan setting as picture 4.2.2-1;

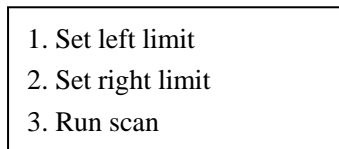

Picture4.2.1-1

Dome scan setting include the: Left limit, Right Limit and Run scan

Press **【1】** to set the Left limit as picture 4.2.2-2 show.

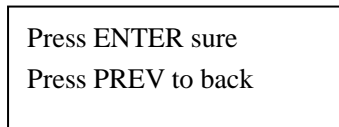

Picture 4.2.2-2

While enter the dome limit setting menu, move the dome to the suitable position, and press**【Enter】**to save and will show “Success” and back to previous menu.

Select the item 2 to set the Right limit, and do the same as the left limit setting,

Back to the menu and press **【3】** to operate the Run Scan.

Warning:

Under commonly mode, Dome can not control by operate the keys and move the joysticks ; While enter the dome preset menu, the keyboard navigate keyboard can directly control the dome and lens control zone also can control the dome’s lens.

4.2.3 Pattern set up

Enter the menu as the picture (4.1.1-1)

Press **【2】** enter the dome setting menu as the picture (4.2.1-1);

And then press **【3】** enter the pattern setting as picture 4.2.3-1 show

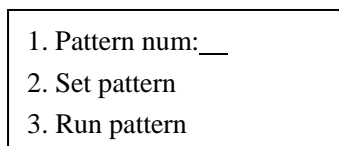

Picture4.2.3-1

After enter the menu, the system need input the pattern information you want, you can put in the NOI~4 and Press the **【ENTER】** . The mouse will skip to the next item automaticly to set the second patter you need. If you already have it, you can skip it and select the **【3】** to run the pattern directly.

Pattern setting: After enter the pattern setting menu, move the dome do the suitable position and press the **【1】** to start record the scan track. The screen will display “Start ……”, like the picture4.2.3-2. Press “0 ” to finish the scan record, and the screen will show “Success” and back to the previous menu.

Press 1 to start
Press 0 to start
Press PREV to back

Picture 4.2.3-2

Warning:

Under commonly mode, Dome can not control by operate the keys and move the joysticks ; While enter the dome preset menu, the keyboard navigate keyboard can directly control the dome and lens control zone also can control the dome’s lens.

4.2.4 Tour set up

Press **【2】** enter the dome setting menu, as the picture 4.2.1-1 show, And then press **【4】** enter the tour setting as the picture 4.2.4-1 show.

1. Tour num:____
2. Insert preset
3. Run tour

Picture 4.2.4-1

After enter the menu, you need input the TOUR information, the range you can put is 1~6, and press the **【ENTER】**confirm. Then the mouse will auto skip to the second TOUR setting. If first one is ok, Users can skip it. And it will show the “Success” and back to the previous menu.

Select the Item 2 as picture (4.2.4-2) , you need input the tour preset, and in the second item you need put in the speed information, the range is (1-127) ; In the third item you need input the time how long it need to stop, the range is (1-255) . After finishing all the step, press the **【ENTER】** and will display “Success” and back to previous menu.

1. Preset num:____
2. Speed :
3. DWell :

Picture 4.2.4-2

Press **【3】** Run the TOUR

Attention:

This model have no the insert tour preset function

4.3 Protocol set up

Enter the menu as picture (4.1.1-1) , Press **【3】** enter the Protocol setting as picture (4.3-1)

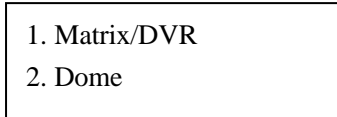

Picture 4.3-1

4.3.1 Pelco Matrix model

Press **【1】** enter the PELCO Matrix model as the picture (4.3.1-1);

And then press the **【ENTER】** to select the Protocol and back to previous menu.

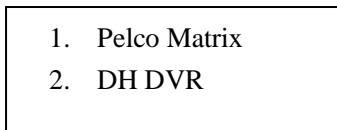

Picture 4.3.1-1

4.3.2 Dome control model

Press **【2】** enter the dome control model as the picture (4.3.2-1).

According to the user's need, select the suitable PROTOCOL and back to the previous menu.

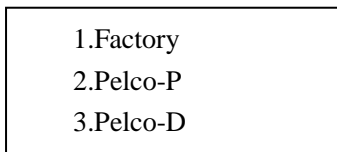

Picture 4.3.2-1

Enter the menu as picture (4.1.1-1) and press the **【5】** to exit the menu.

5. Appendix

5.1 RS485 Bus Basic Knowledge

●RS485 Bus Basic Character

According to RS485 industrial standards, RS485 Bus is of half-duplex data transmission cables with characteristic impedance as 120. The maximum load capacity is 32 unit loads (including main controller and controller equipment)

●Distance of RS485 bus transmission

While use the 0.56mm (24AWG) twisted cable as the communication, the farthest distance it can reach as follow based on the different Baud rate:

Baud rate	Farthest Distance
2400bps	1800M
4800bps	1200M
9600bps	800M
19200bps	600M

If user selects thinner cables, or installs the dome in an environment with strong electromagnetic interference, or connects lots of equipment to the RS485 Bus, the maximum transmitting distance will be decreased. To increase the maximum transmitting distance, do the contrary.

● **Connection and termination resistance**

The RS485 standards require a daisy-chain connection between the equipment. There must be termination resistance with 120 impedance at both ends of the connection (refer to picture 4-1.1). Please refer to picture 4-1.2 for simple connection But “D” should not exceed 7m.

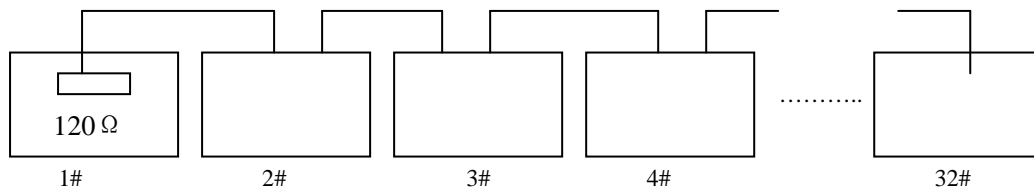

Picture 4-1.1

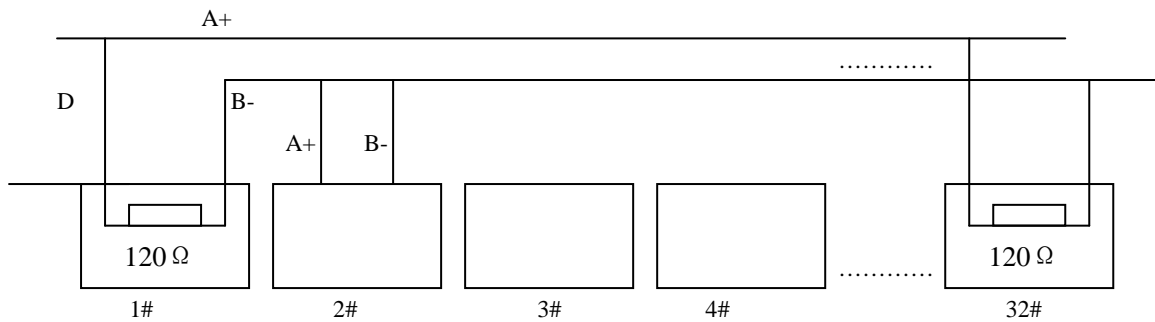

Picture 4-1.2

● **Problems in practical use**

In some circumstances user adopts a star configuration in practical connection. The termination resistors must be connected to the two equipments that are father away from each other, such as equipment 1# and 15# (refer to picture 4-1.3). As the star configuration is not in conformity with the requirements of RS485 standards, problems such as signal reflections, lower anti-interference performance arise when the cables are long in the connection. The reliability of control signals are decreased with the phenomena that the dome dose not responds to or just responds at intervals to the controller, or dose continuous operation without stop.

In such circumstances the factory will recommends the usage of Rs485 distributor. The distributor can change the star configuration connection to the mode of connection stipulated in the RS485 standards. The new connection achieves reliable data transmission (refer to picture 4-1.4)

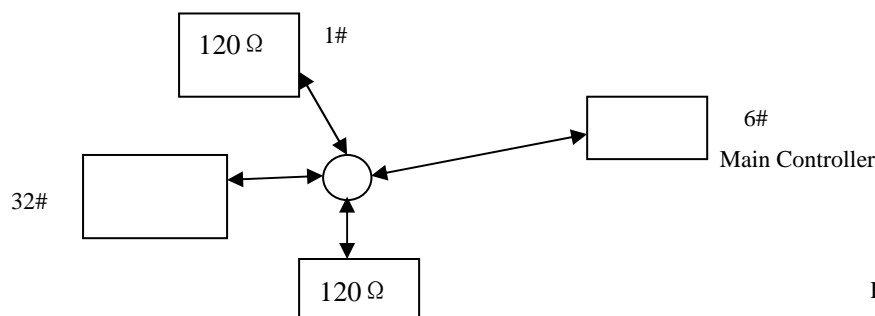

Picture 4-1.3

15 #

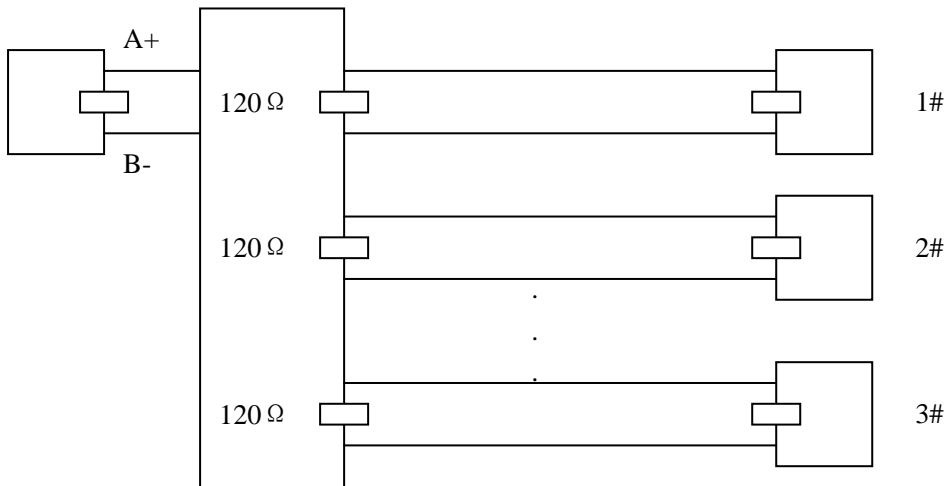

Picture 4-1.4

5.2 Keyboard shortcut operation manual

Working Mode	shortcut	Operation object	Function
Direct Control Mode	Press 【SET】 for 2 seconds	Keyboard	IR remote ON/OFF
	Press 【MENU】 for 2 seconds	Keyboard	Enter the system setting
	【N】 + 【CAM】	High speed dome	Input Dome ID, press 【CAM】 to select object dome.
	【Rotate the joystick anti-clockwise】	High speed dome	Zoom in
	【Rotate the joystick clockwise】	High speed dome	Zoom out
	【FAR】	High speed dome	Press 【FAR】 , far focus
	【NEAR】	High speed dome	Press 【NEAR】 , near focus
	【CLOSE】	High speed dome	Press 【CLOSE】 , reduce iris
	【OPEN】	High speed dome	Press 【OPEN】 , increase Iris
	【SET】 + 【N】 + 【PRESET】	High speed dome	Adjust the image to object position, Press 【SET】 to input the preset, and press 【PRESET】 to set the preset
	【N】 + 【PRESET】	High speed dome	Input preset ID, press 【Preset】 to call the preset
	【SHI】 + 【1】 + 【ENT】	High speed dome	ON/OFF water Wiper
	【SHI】 + 【2】 + 【ENT】	High speed dome	ON/OFF auxiliary light
【SET】 + 【1】 + 【SCAN】	High speed dome	Adjust the image to object position, press Set to input	

			【1】 , then press Scan to set 【scan】 left limit.
	【SET】 + 【2】 + 【SCAN】	High speed dome	Adjust the image to object position, press Set to input 【2】 , then press 【Scan】 to set scan right limit.
	【1】 + 【SCAN】	High speed dome	Input 【1】 , press 【Scan】 to run scan.
	【SET】 + 【N】 + 【PATTERN】	High speed dome	Press 【Set】 to input pattern number, press 【Pattern】 to record pattern path.
	【SET】 + 【0】 + 【PATTERN】	High speed dome	Press 【SET】 and input 0, Press 【PATTERN】 to save path
	【N】 + 【PATTERN】	High speed dome	Input the pattern path (1-4), Press 【PATTERN】 to start pattern
	【N】 + 【TOUR】 / 【TOUR】	High speed dome	Input the TOUR NO, press 【TOUR】 or directly press 【TOUR】 to start the Tour
	【9】 + 【5】 + 【PRESET】	High speed dome	Input 95 and press 【Preset】 to call the menu
PELCO Matrix Mode	【SHIFT】 + 【SET】	Matrix	Press 【SHIFT】 and 【SET】 to call the matrix menu
	【PREV】	Matrix	Press 【PREV】 skip to the previous dome, hold on 2sec on 【PREV】 to continuously skip the sixteen domes of connection matrix forwards
	【NEXT】	Matrix	Press 【NEXT】 skip to the previous dome, hold on 2sec on 【NEXT】 to continuously skip the sixteen domes of connection matrix backwards
	【Stop】	Matrix	Stop switch
	【ENTER】	Matrix	After program, press 【Enter】 to confirm.。
	【N】 + 【MON】	Matrix	Input monitor ID, press 【Cam】 to select object monitor

