



BIGI 250

User Manual



www.princetonpower.com
4411-0009, Rev 0.6
June 05, 2013

Copyright

© Copyright 2013 Princeton Power Systems, Inc.
3175 Princeton Pike
Lawrenceville, NJ 08648
Tel: 609-955-5390
Fax: 609-751-9225

Email: info@princetonpower.com

Princeton Power Systems, and "Clean Power made simple" are registered trademarks of Princeton Power Systems, Inc.

Specifications and descriptions in this document were in effect at the time of publication. Princeton Power Systems, Inc. reserves the right to change specifications, product appearance or to discontinue products at any time.

No patent infringement liability is assumed by Princeton Power Systems, Inc. with regards to the use of information, circuits, equipment, or software described in this manual.

The statements and information in this document must not be changed without special notification from Princeton Power Systems Inc. Furthermore, Princeton Power Systems Inc. does not commit to any further obligations with this document. Use and reproduction is only permitted in accordance with the contractual agreements with Princeton Power Systems. Under no circumstances may parts of this publication be copied, reproduced, stored in a retrieval system or translated into another language, except with written permission from Princeton Power Systems, Inc.

About This Manual

Purpose

The purpose of this User Manual is to provide explanations and procedures for operating, maintaining, and troubleshooting BIGI-250.

Scope

The manual provides safety guidelines and information about operating and troubleshooting the unit. It does not provide details about particular brands of batteries. You need to consult individual battery manufacturers for this information.

Audience

The manual is intended for anyone who needs to operate the BIGI-250.

Organization

This manual is organized into 5 chapters and 3 appendices.

Chapter 1, “Introduction” provides an overview of the BIGI-250.

Chapter 2, “Basic Setup Programming” provides a tutorial on operating the inverter from the front panel.

Chapter 3, “System Operation” provides detailed explanation of how to configure and operate the BIGI- 250. Also, it describes various system faults.

Chapter 4, “Maintenance” reminds the operator that there are no user-serviceable parts in the BIGI-250 and provides instructions regarding the kinds of maintenance that can be performed by the operator.

Appendix A, “BIGI-250 Specifications” provides the electrical and environmental specifications of the BIGI-250.

Appendix B, “Parameter List” is a sequentially numbered list of all BIGI-250 Parameters and addresses.

Appendix C, “Return Material Authorization, Product, and Contact Information” This chapter provides instructions for obtaining a Return Material Authorization, if the product needs to be returned to Princeton Power Systems or one of its authorized service centers; contact information, and a place to enter information that may be required if you need to contact PPS about your system.

Abbreviations and Definitions

The following table provides a glossary of technical terms used in this manual. The glossary also defines some common acronyms and electrical terms that may be used in this manual.

Abbreviations	Definition
AC	Alternating Current
ATS	Automatic Transfer Switch
BIGI	Battery Integrated Grid Interactive
DC	Direct Current
DRI	Demand Response Inverter
ESD	Electro-Static Discharge
GFDI	Ground Fault Detector and Interrupter
HMI	Human/Machine Interface
Modbus	A Serial Communications Protocol
NEC	National Electric Code
PPS	Princeton Power Systems





Abbreviations	Definition
PV	Photovoltaic
UART	Universal Asynchronous Receiver/Transmitter
UL	Underwriters Laboratories
UPL	Universal Programming List

Important Safety Instructions

SAVE THESE INSTRUCTIONS– This manual contains important instructions for the BIGI-250 that shall be followed during installation and maintenance of the inverter.

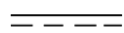
Symbols

The following is a list of symbols that may be used in this manual and on labels in the DRI 100 kW.

	DC circuit
	AC circuit
	Phase indicator
	Protective earth ground.
	Other grounding conductor.

Warning Symbols used in This Manual



Attention: This symbol identifies information about circumstances or practices that could lead to personal injury, death, internal component damage, reduced product life, equipment damage, economic loss, or other adverse effects.



Shock Hazard: This symbol identifies information about a condition or procedure that could be potentially lethal or harmful to personnel or damaging to components due to live voltages within the system, components holding stored energy, or electrostatic discharge (ESD).

General Precautions



For Proper Circuit Isolation: Connect a minimum 250kVA rated isolating transformer between the output of the inverter and the utility power line connections. The transformer is to be an isolation type having separate primary and secondary windings.



Maintenance by Qualified Personnel: Only personnel familiar with the Princeton Power BIGI-250 Inverter and associated machinery should attempt installation, commissioning, or maintenance of the system. Untrained or unauthorized personnel run the risk of grave personal injury, death, or equipment damage.



High Voltage Electric Shock Hazard: The Princeton Power BIGI-250 Inverter contains electrical components carrying potentially lethal voltages and currents. Extreme caution should be exercised around the system, especially when the cabinet door is open. Before opening the cabinet, all supply power should be disconnected using a standard physical lock-out procedure and the service personnel should wait 15 minutes prior to opening the enclosure door.



Improper Use: Princeton Power cannot assume responsibility for personal injury and/or equipment damage as a result of improper installation, use, maintenance, reconfiguration, reprogramming, or other improper actions. An incorrectly serviced or operated Inverter system can cause personal injury, component damage, or reduced product life. Malfunction may result from wiring errors, an incorrect or inadequate DC supply or AC grid connection, excessive ambient temperatures or obstructed ventilation, or incorrect software configuration.



Heat Hazard: The cabinet should not be mounted on a combustible surface nor should combustible materials be placed on or against the cabinet. The system should not be installed in a confined space that prevents proper ventilation or allows the build-up of excessive heat. A minimum of 12 inches of spacing clearance must exist for proper cooling airflow into and out of ventilation openings.

Usage and Maintenance

1. There are no user serviceable parts in the Inverter. All maintenance must be done by trained and certified Electricians or Technicians.
2. Unless the Inverter is being serviced by trained and certified Electricians or Technicians, the enclosure doors must remain locked at all times – All door latches are equipped with a provision that allows for locking a door in the closed position.
3. Keep vents and air outlets clear of debris and provide proper airflow. Do not place or store any objects on the enclosure roof.
4. Keep all guards, screens, and electrical enclosures in place when the system is operating.



Safety Checks

Performing a routine safety check before energizing the Inverter will minimize the risk of injury to the operator and minimize the potential for damaging the unit.

Before operating the unit, check for obvious signs of damage or concern. The following is a list of suggested items to be checked before operating the unit:

1. Check the enclosure for obvious signs of damage.
2. Verify that all inlet and outlet vents are clear of debris.
3. Check external wires and cables for signs of damage, such as fraying or cracked insulation.
4. Check the location and unit for potential hazards, such as standing water on the floor or on the BIGI-250.

Note: Additional safety checks may be necessary depending on the particular installation of the unit. The safety checklist above is not intended to be all-inclusive.

Resolve all issues before operating the inverter. Contact Princeton Power Systems if necessary.

Battery Related Precautions



WARNING: The battery charge control function has adjustable battery charging settings. The user must confirm that the charge control profile used in this inverter is appropriate and safe for the type of battery used and that all battery charging settings are set correctly for the battery voltage, current, and temperature ratings. Setting these settings incorrectly may damage the battery and the inverter and may cause a hazardous condition that puts personnel at risk of grave injury or death.



WARNING: Programming temperature compensation parameters that are not suitable for the type of battery being used may damage the battery and the inverter and may cause a hazardous condition that puts personnel at risk of grave injury or death. The user must ensure that the battery temperature compensation parameters are appropriate and safe for the type and voltage rating of the battery used.

Terms of Use

Because of the wide variety of uses for power electronics equipment, this manual does not describe every possible application or configuration. All technicians responsible for installing, commissioning, and operating this equipment must satisfy themselves of the suitability and proper implementation of the intended application of this power conversion product.

In no event will Princeton Power Systems, Inc., its subsidiaries, partners, employees, or affiliates be responsible or liable for any damages, indirect or direct, resulting from the misuse or incorrect application of this equipment.

The examples and diagrams in this manual are for illustrative purposes only. Because of the wide variety of uses, applications, peripheral equipment, and facility configurations particular to each installation, Princeton Power Systems, Inc. cannot assume responsibility or liability for actual use based on the information provided herein.

This page intentionally left blank.

Contents

About This Manual.....	ii
Purpose	ii
Scope	ii
Audience	ii
Organization	iii
Abbreviations and Definitions	iii
Important Safety Instructions.....	iv
Symbols	iv
Warning Symbols used in This Manual	v
General Precautions	v
Usage and Maintenance	vi
Safety Checks	vi
Battery Related Precautions	vi
Terms of Use.....	vii

Introduction **14**

1

1.1 Overview	15
1.2 Functional Specifications.....	15
1.2.1 Ports and General Features.....	15
1.2.2 Grid Functions.....	15
1.2.3 Battery Functions	16
1.2.4 PV Functions.....	17
1.3 BIGI Power Flow Control	17
1.3.1 Control Modes.....	18
1.3.2 Grid Support Mode	19

Basic Setup Programming **21**

2

2.1 Basic Operation	22
2.1.1 Navigation.....	22

System Operation **26**

3

3.1 System Operation and Parameters	27
3.1.1 General System Info Parameters	27
3.2 Front-Panel Interface	28
3.3 MODBUS Interface	28
3.3.1 Introduction.....	28
3.3.2 MODBUS Setup	29
3.3.3 RS-232 Hardware Configuration	30
3.3.4 Half-Duplex RS-485 Hardware Configuration	31
3.3.5 Full-Duplex RS-485 Hardware Configuration	33
3.3.6 Supported MODBUS Functions	34
3.4 Web Interface	37

Contents

3.4.1	Web User Interface Setup	37
3.4.2	Features	38
3.4.3	Web Interface Parameters	39
3.5	Password Protection	40
3.5.1	Password Protection Setup	40
3.5.2	Password Protection Parameters	40
3.6	Inverter Configuration Parameters.....	41
3.7	Inverter Control Parameters.....	43
3.8	Inverter Monitoring Parameters.....	45
3.9	PV Control Setting Parameters.....	51
3.10	Battery Control Setting Parameters.....	52
3.11	Grid Control Setting Parameters	57
3.12	Reserved Section.....	59
3.13	Reserved Section.....	59
3.14	Control Function Owners Parameters	59
3.15	Inverter Status Registers.....	60
3.16	Digital Input Parameters.....	61
3.17	Digital Output Parameters	63
3.18	Analog Input Parameters.....	65
3.19	Analog Output Parameters	68
3.20	Alarm Parameters.....	71
3.20.1	Master Alarm Parameters.....	72
3.20.2	Alarm Status Parameters	72
3.20.3	Inverter Overload Current Alarm.....	73
3.20.4	Battery Under Voltage Alarm	73
3.20.5	Battery Under Temperature Alarm	73
3.20.6	Grid is Within the Reconnect Window Alarm	73
3.20.7	Heat Sink Temperature Alarm	73
3.20.8	Loss of Signal Alarm	74
3.20.9	Auto-Restarting Alarm.....	74
3.20.10	User Configurable Alarm	74
3.21	Auto Restart	75
3.22	System Faults	76
3.22.1	Central Cap Over Voltage Fault.....	77
3.22.2	Battery Port Over Voltage Fault.....	77
3.22.3	Battery Port Over Current Fault.....	78
3.22.4	PV Port Over Voltage Fault	78
3.22.5	PV Port Over Current Fault.....	78
3.22.6	Grid Port Over Current Fault	78
3.22.7	Setup Wizard Fault.....	78
3.22.8	Ground Fault	78
3.22.9	Central Cap Under Voltage Fault.....	78
3.22.10	IGBT Bridge Error Fault	78
3.22.11	Inverter Over Voltage Fault.....	78
3.22.12	Grid Port Over Voltage Fault	78
3.22.13	Internal Faults	79
3.22.14	Inverter Overload Fault	79
3.22.15	Inverter Over Temperature Fault.....	79
3.22.16	Inverter Temp Sensor Failure	80
3.22.17	Loss of signal fault	80

3.22.18	User-defined Trip	80
3.22.19	External Trip.....	81
3.22.20	Max Retries Fault	81
3.22.21	Bootup Fault	82
3.22.22	LCD Communication Loss Fault.....	82
3.22.23	Calibration Load Fault.....	82
3.22.24	Communication Loss.....	82
3.22.25	Master Command Loss Fault.....	83
3.22.26	Synch Signal Loss	83
3.22.27	Grid Contactor Fault.....	83
3.22.28	GFDI Error Fault	83
3.22.29	Fan VSD Failure.....	83
3.23	PV Control Fault Definitions	83
3.23.1	PV Over Voltage Fault.....	83
3.24	Battery Control Fault Definitions.....	83
3.24.1	Battery Over Voltage Fault	84
3.24.2	Battery Under Voltage Fault	84
3.24.3	Battery Over Temperature Fault	84
3.24.4	Battery Over Charge Capacity Fault	84
3.24.5	Battery Pre-charge Timeout.....	85
3.24.6	Battery Under Temperature.....	85
3.25	Grid Control Faults	86
3.25.1	Wrong Phase Order Fault.....	86
3.26	Backup Control Faults.....	86
3.26.1	Synchronization to Master Fault (Backup Mode)	86
3.27	Fault Buffer	86

Maintenance 91

4

4.1	Airflow	92
4.2	Access to the Interior of the Inverter	92
4.3	Data Log Reviews	93

Specifications 95

A

BIGI-250 Specifications.....	96
------------------------------	----

BIGI-250 Parameter List 99

B

Table of Parameters.....	100
--------------------------	-----

BIGI 250 Default Trip Settings 123

C

Return Material Authorization 125

D

D.1 Return Material Authorization Policy..... 126
 D.2 Out of Warranty Service 126
 D.3 Contact Information..... 126
 D.4 Information About This System 126

Figures

Figure 2-1 Front Panel Interface 22
 Figure 2-2: Front Panel Menu Structure 23
 Figure 2-2: Set up Wizard..... 25
 Figure 3-1: Parameter Symbols..... 27
 Figure 3-2: Parameters containing version and set up information. 28
 Figure 3-4: J66 RS232 Signal Pin out..... 30
 Figure 3-5: RS-232 Dip Switch Configuration 31
 Figure 3-6: RS 485 Half Duplex Dip Switch settings no bias 31
 Figure 3-7: RS 485 Half Duplex Switch settings with bias 32
 Figure 3-8: RS 485 Half Duplex Multidrop Configuration Pin out 32
 Figure 3-9: RS 485 Half Duplex multiple slave configuration dip switch settings 32
 Figure 3-10: RS 485 Full Duplex Configuration 33
 Figure 3-11: RS 485 Full Duplex pin configuration 33
 Figure 3-12: RS 485 Full Duplex slave dip switch settings 33
 Figure 3-13: Supported Modbus Functions 34
 Figure 3-14: Ethernet Jack 37
 Figure 3-15: Ethernet Jack Location 38
 Figure 3-16 – Digital input configuration – Terminals on header J27 62
 Figure 3-17: Digital Input Parameter ID’s 62
 Figure 3-18: Digital Output Parameter ID’s 64
 Figure 3-19: Interface I/O Card – Analog Inputs 66
 Figure 3-20 Analog Input Signal Range 67
 Figure 3-21: Analog Input Parameter ID’s 67
 Figure 3-22 Interface I/O Board - Digital Outputs..... 69
 Figure 3-23: Analog Output Signal Range 70
 Figure 3-24: Analog Output Parameter ID’s..... 71
 Figure 4-1: System Faults and ID’s 77
 Figure 5-1. Ventilation Clearances 92

Tables

Table A.1-1: BIGI-250 Specifications 97
Table B.1-1: BIGI-250 Parameter List 121

1

Introduction

1.1 Overview

The Battery Interactive Grid Interactive (BIGI) Inverter is a multi-port power converter that allows for the seamless combination of renewable power generation with energy storage into one power delivery system.

The system is designed to provide grid support functionality for grid-connected systems including on-command real power delivery for frequency regulation and demand response as well as on-command reactive power delivery for voltage regulation. The BIGI is compatible with advanced communications protocols including the IEC 61850 communication protocol that includes a number of important grid support capabilities.

1.2 Functional Specifications

1.2.1 Ports and General Features

The BIGI-250 is a Battery Integrated Inverter that offers high efficiency, proven reliability, and unprecedented flexibility. The BIGI-250 is highly configurable and has three independent ports, designed to combine battery with PV.

1.2.1.1 Grid Port

The Grid Port facilitates bidirectional power exchange with an AC power source.

1.2.1.2 Battery Port

The Battery Port facilitates bidirectional power exchange with a DC power source or DC energy storage system.

1.2.1.3 PV

The PV Port draws power from a connected PV array.

1.2.1.4 GFDI

The BIGI has a Ground Fault Detector/Interrupter (GFDI) that can be used to ground the common negative terminal of all DC ports. It is compliant with NEC requirements.

1.2.2 Grid Functions

1.2.2.1 UL-1741

The Grid Port conforms to the over/under voltage, over/under frequency, automatic anti-islanding, Total Harmonic Distortion, and all other functional requirements of the UL code UL-1741-2010.

1.2.2.2 Real Power on Demand

The Grid Port is able to control the flow of Real Power to and from the Grid based on a dedicated Real Power command. The limit of this function is the amount of combined available capacity of the other two ports.

1.2.2.3 Reactive Power Control

The Grid Port is able to control the supply of Reactive Power to the grid independently from Real Power based on a dedicated reactive power command. The limit of this function is the remaining capacity of the

grid port beyond what is used to supply the commanded Real Power.

1.2.2.4 Battery Disconnect

The BIGI has an integrated manual Battery disconnect that complies with UL and NEC specifications for connecting a battery to the Battery Port.

1.2.2.5 AC Disconnect

The BIGI has an integrated fused manual AC disconnect that complies with UL and NEC specifications for connecting the Grid Port to an AC supply.

1.2.2.6 Isolation Transformer

The BIGI requires an isolation transformer for isolating the inverter from the grid supply so that one of the other Ports may be referenced to ground. In order to minimize “night-time tare losses” this transformer is deactivated when the grid port is not in use by the electronically controlled Grid Isolation Contactor that is used for UL-1741 compliance. This External transformer is rated at 300kVA Delta Y 480:480.

1.2.2.7 External Grid Contactor (Optional)

BIGI can control an optional external grid contactor to automatically disconnect itself from the grid in case of a power outage.

1.2.3 Battery Functions

1.2.3.1 Automatic Charging Profile

The battery port is capable of executing a typical bulk/float charging profile with adjustable current and voltage set points.

1.2.3.2 Advanced Charging Profiles

The BIGI system is also capable of communication with battery management systems in order to facilitate custom battery charging protocols. The system supports the following communication protocols for BMS communication

1. Modbus over RS232/485
2. CANBUS

The system is compatible with most commercial battery systems.

1.2.3.3 Temperature Compensation

The BIGI system supports automatic temperature compensation of battery charge voltage based on a single temperature feedback. This feedback can be delivered via digital communication from a remote system, or a temperature sensor can be connected and configured as an analog input to the BIGI.

1.2.3.4 Pre-charge function

The BIGI includes a pre-charging circuit that protects the BIGI from excessive inrush current upon connecting a battery to the Battery Port. The pre-charge circuit automatically pre-charges the internal capacitors of the BIGI when a battery is connected. The pre-charge circuit outputs a signal when pre-charging is complete and it is safe to close the main battery disconnect that connects the battery to the main Battery Port terminals. This signal will deactivate if the battery is disconnected by the user after this

point, and will only reactivate once the pre-charge process has been completed again. The state of this signal will be stored in a parameter, so it is possible to map this signal to a digital output of the BIGI and to read its status via digital communication with the BIGI.

1.2.3.5 DC Disconnect

The BIGI requires an external manual DC disconnect that complies with UL and NEC specifications for connecting a battery to the Battery Port.

1.2.4 PV Functions

1.2.4.1 MPPT

The PV Port utilizes a state-of-the-art Maximum Power Point Tracking (MPPT) technique to maximize PV power production for polycrystalline and thin film panels.

1.2.4.2 Wake/Sleep

The PV Port activates only when sufficient PV power is available to warrant activation. The PV port will activate *any* time sufficient PV power becomes available.

1.2.4.3 DC Disconnect

The BIGI has an external manual DC disconnect that complies with UL and NEC specifications for connecting a PV array to the PV Port.

1.3 BIGI Power Flow Control

The BIGI power flow control scheme defines how power is routed among the 3 ports of a BIGI based on situational conditions and system settings. This power flow control scheme governs real power flow only. Reactive power flow is controlled otherwise for grid support purposes.

The general concept of the control scheme is that there is a hierarchy among the 3 ports of the BIGI in terms of which port has the obligation to support the power requirements of the other ports. In Battery Port Control Mode, the Grid Port has the highest obligation of support, followed by the Battery Port, while the PV Port has the least obligation. In Grid Support Mode, when the Grid Port is commanded to deliver real power to the grid for demand response, peak shaving, frequency regulation, or other grid support functions, then the ranks of the Grid Port and Battery Port are swapped – the Battery Port then has the highest obligation of support, followed by the Grid Port, while the PV port has the least obligation.

1.3.1 Control Modes

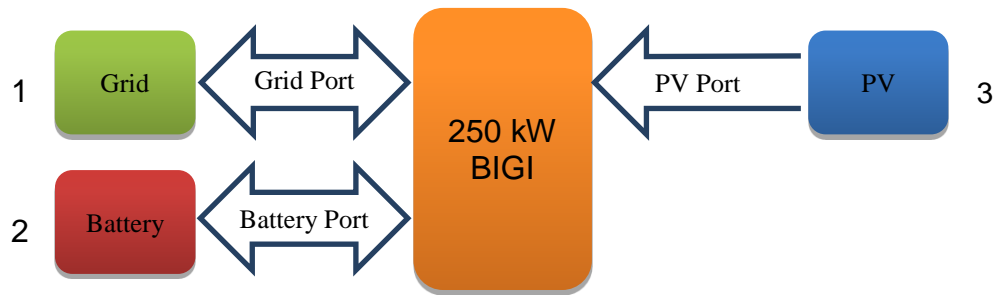

Figure 1-1. Control Modes: Hierarchy of Power Support Obligation among Ports

1.3.1.1 Grid Port

In Battery Port Control Mode, the Grid Port has the 1st obligation to support the other three ports. It supplies all the power required to support the activities of the other two ports, whether the amount required is positive or negative, within allowable limits. The allowable limits are defined by 1) the hardware limits of the machine, which in this case is 250kW, and 2) user-defined limits. If the allowable limits prevent the Grid Port from being able to supply sufficient power, then it will supply the maximum allowable.

1.3.1.2 Battery Port

In Battery Port Control Mode, the Battery Port has the 2nd obligation to support the Grid and PV Ports. The function of the Battery Port in this mode is to charge/discharge the battery at the rate specified by the Power Command. It will do so as long as the Grid Port can support the resulting power flow. If the Grid Port cannot support this battery charging as well as the net power draw from the other two ports, then the Battery Port will adjust its power flow to what the PV Port and Grid Port can supply. This may even require drawing power from the battery. The Battery Port, however, like the Grid Port, will not exceed allowable limits defined either by the machine hardware or by user charge/discharge rate limits.

1.3.1.3 PV Port

By default, the PV port will constantly implement MPPT to deliver the maximum possible amount of PV power. If, however, the Grid Port and Battery Port in combination are unable to support the net power flow of the PV Port and this power flow is POSITIVE, (for instance if the Grid Port has a user-set power export limit that is low and the battery is fully charged, but there is a large amount of available PV power) then the PV Port has the 3rd obligation to reconcile the power deficit. In this case, the PV Port will limit its delivery of PV power to whatever amount can be handled by the other three Ports in combination.

1.3.2 Grid Support Mode

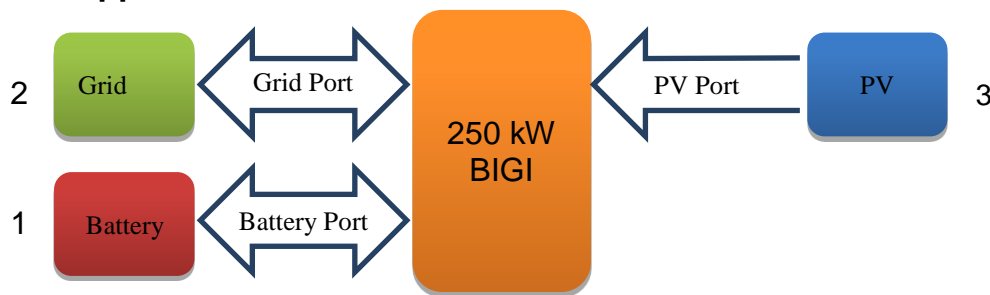

Figure 1-2. Grid Support Mode: Hierarchy of Power Support Obligation among Ports

1.3.2.1 Grid Port

If the Grid Port is required to deliver real power of a specific value for execution of a grid support function such as peak shaving or demand response (Grid Support Mode), then the 1st obligation to support other ports is transferred to the Battery Port, and the Grid Port takes on 2nd obligation. The function of the Grid Port in this mode is to deliver (or draw) the amount of power specified by the Power Command. It will do so as long as the Battery Port can support the resulting power flow. If the Battery Port cannot support this power flow, the Grid Port will adjust its power flow to what the PV Port and Battery Port can supply. The Grid Port, however, will not exceed allowable limits defined either by the machine hardware or by user charge/discharge rate limits.

1.3.2.2 Battery Port

In Grid Support Mode, the Battery Port has the 1st obligation to support the other three ports. It supplies all the power required to support the activities of the other three ports, whether the amount required is positive or negative, within allowable limits. The allowable limits are defined by 1) the hardware limits of the machine, 2) user-defined limits, and 3) battery charging settings. If the allowable limits prevent the Battery Port from being able to supply sufficient power, then it will supply the maximum allowable.

1.3.2.3 PV Port

The PV Port operation is the same in both Battery Port Control Mode and in Grid Support Mode. See Figure 1-.

This page intentionally left blank.

2

Basic Setup Programming

2.1 Basic Operation

To help differentiate parameter names and display text from other text, this manual uses certain formatting conventions:

Parameter names will appear **[Bold and In Brackets]**.

Front Panel Interface text will appear in Courier Font.

2.1.1 Navigation

The front panel interface shown in

Figure 2-1 Front Panel Interface is used to view and change all system parameters. This interface can be used to configure the inverter and to control the inverter while it is running. The LCD screen displays either a list of menu options or a list of parameters at all times. Menu options or parameters are selected by scrolling to the desired item using the navigation knob and then pressing the “Enter” button. Pressing the “Esc” button will bring you back to the previous menu page or cancel the parameter change.

The parameters are organized into groups in a way that mirrors their organization in System Operation and Parameters Section of the user manual. For example, if a particular parameter is described in Sub-section 18 of that section, then that parameter will be found under menu selection 18 under the View/Change Params option on the front panel interface.



Figure 2-1 Front Panel Interface

2.1.1.1 Menu Structure

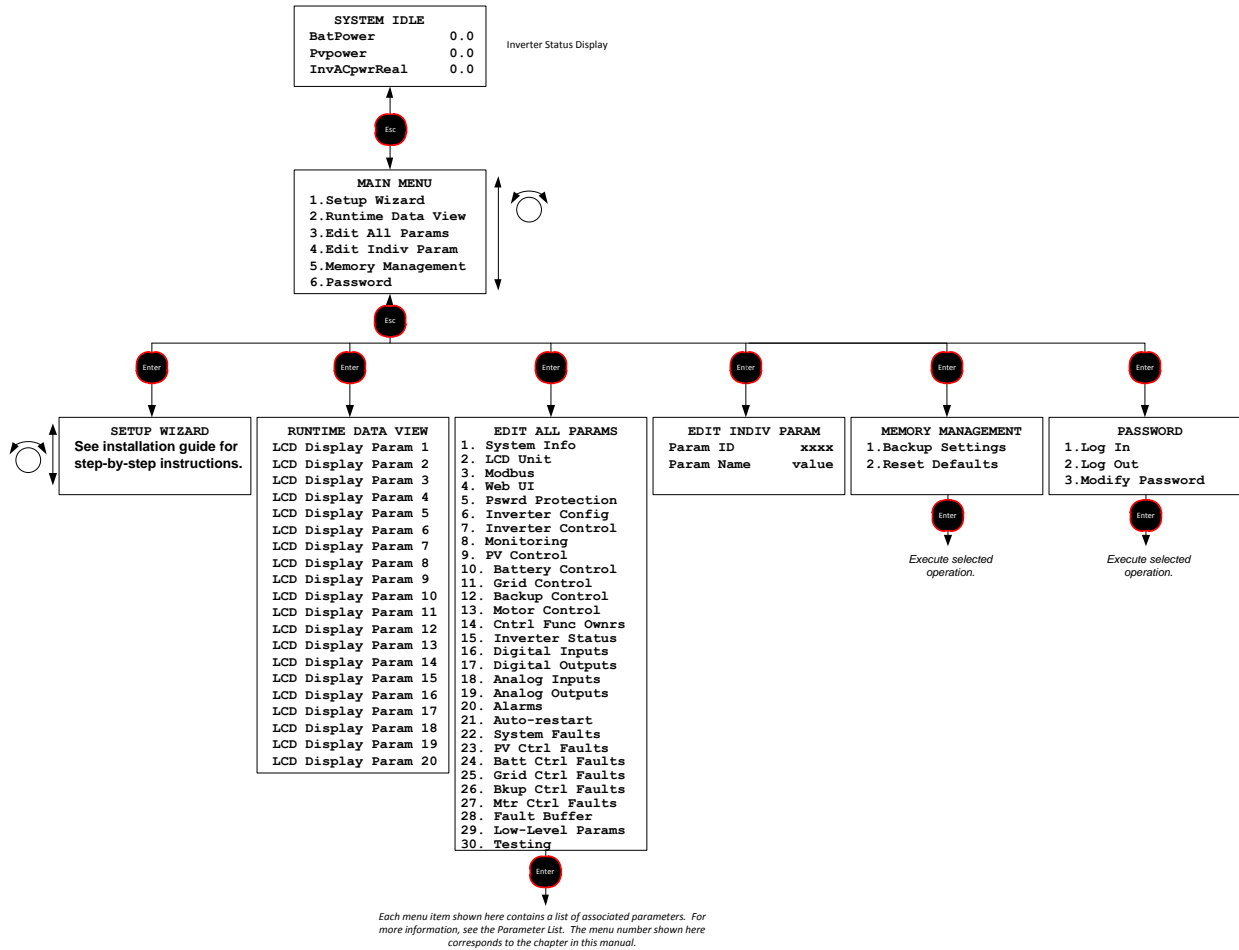

Figure 2-2: Front Panel Menu Structure

2.1.1.2 Inverter Status Screen/Home Screen

When the inverter is first powered-on, the LCD screen will display the Home Screen. This screen displays the present inverter status at the top, and the following three parameters:

- [Battery Power]
- [PV Power]
- [Inverter AC Power Real]

The display will always return to this home screen after 5 minutes of inactivity on the Front Panel Interface. The Home Screen can be accessed at any time by pressing “Esc” from the Main Menu.

2.1.1.3 Main Menu

The Main Menu is accessed by pressing “Esc” from the Home Screen. The Main Menu can also be accessed from any part of the menu structure by repeatedly pressing “Esc” until the Main Menu is reached again. Reminder: Pressing “Esc” while viewing the Main Menu will take you to the Home Screen and pressing “Esc” from the Home Screen will bring you back to the Main Menu.

The Main Menu contains a list of options. Scroll to the desired option using the navigation knob and press “Enter”.

2.1.1.4 Editing Parameters

To edit any parameter, navigate to that parameter within the menu structure until the cursor arrow is next to the parameter you want, and press “Enter”. If you have permission to edit that parameter at that time, the parameter value will begin blinking. Use the navigation knob to scroll the value of the parameter up or down to the desired value and then press “Enter” to save the new value. The message “Parameter Downloaded” will appear briefly if the new value is saved successfully. You can press “Esc” at any time while editing the value to abort the change, and the parameter will remain at its previous value.

You will not be allowed to edit certain parameters at certain times for a number of possible reasons:

- 1) The parameter is not allowed to be changed while the inverter is running
- 2) You have not entered a password appropriate for the level of access associated with that parameter
- 3) The parameter is read-only
- 4) The Front Panel Interface does not have “ownership” of the parameter.

If you are not allowed to edit a parameter when you attempt to change it, a message will display briefly explaining the reason, and no changes will be made.

Editing Binary Parameters

A small number of system parameters are binary parameters, meaning that they are displayed as a string of 16 digits, each of which is a zero or a one. These parameters are edited one digit at a time. Select the parameter using the navigation knob and press “Enter”. The first digit of the parameter that is changeable will begin blinking. Use the navigation knob to scroll the value of that digit to one (up) or zero (down). Then press “Enter” again to move to the next digit. Once you have reached the last digit, pressing “Enter” will save the new parameter value, and the message `Parameter Downloaded` will appear briefly if the new value is saved successfully. Pressing “Esc” at any point before this will abort the changes made to all digits, and the parameter will remain unchanged.

2.1.1.5 Setup Wizard

The Setup wizard provides the user with a quick way to configure the most commonly used inverter parameters. Most applications will not require further setup after the Setup Wizard is completed. The Setup Wizard can be accessed from both the Front Panel and the Web Interface. The instructions below apply to the Front Panel, though the procedure for the Web Interface is identical in most cases.

Operational Note: The inverter will not run until the Setup Wizard has been completed, unless it is preconfigured at the factory.

2.1.1.6 Navigating the Wizard

Selecting `Setup Wizard` from the `MAIN MENU` will take you to the first page of the Setup Wizard.

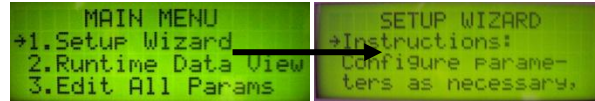

Figure 2-3: Set up Wizard

At the bottom of each screen is a list of options. Read and follow the instructions on each screen, scrolling up and down using the navigation knob, and choose one of the options at the bottom by pressing the `Enter` key. Pressing the `Esc` key at any time will bring you back to the `MAIN MENU`. Changes up to that point will be retained, so you will not have to redo them if you re-start the Setup Wizard. Scrolling the cursor past the last displayed line on the screen will scroll the contents of the screen.

2.1.1.7 Runtime Data Page Parameters

Selecting `Runtime Data View` from the main menu will take you to the Runtime Data Page, which displays a user-configurable list of system parameters at all times.

2.1.1.8 Save / Reset Parameters

Selecting `Memory Management` from the Main Menu will allow you either to save the current parameter settings or reset the parameters to their default settings. This feature is also available through the Web Interface, with the additional ability to save and name individual parameter profiles. Parameter settings will be automatically saved when the VSD starts running.

2.1.1.9 Password and User Access

Writeable parameters are grouped into three levels of access:

Open Access – Operational parameters modifiable by all users.

User Access – Parameters configurable by the facility manager.

Factory Access – Parameters for system commissioning and testing, accessible by Princeton Power's installation and field service technicians.

To view the password options, choose `Password` from the Main Menu. To unlock access to user- or factory-level parameters, choose `Log In` and enter in the appropriate password. Once user- or factory-level access has been granted, the user can modify the password for that level of access by selecting `Modify Passwords`. To revert back to Open Access, select `Log Out`.

3

System Operation

3.1 System Operation and Parameters

The following symbols will be used to describe system parameters











Parameter Symbol	Description
	Open Access Writeable Parameter. Operational parameter modifiable by all users.
	User Access Writeable Parameter. Parameter configurable by the facility manager.
	Factory Access Writeable Parameter. Parameter accessible by Princeton Power's installation and field service technicians.
	Read-Only Parameter. Parameter cannot be modified by the user; it is updated internally.
	Not Readable. The system will always display this parameter as 0. Used for password parameters.
	Binary parameter. Displayed as a string of 16 digits, each of which is a 0 or a 1. These parameters are edited one digit at a time.
	Changeable While Running. This parameter value can be modified while the system is running.
	Analog Input Mappable. Parameter can be mapped to a user analog input channel.
	Analog Output Mappable. Parameter can be mapped to a user analog output channel.
	Digital Input Mappable. Parameter can be mapped to a user digital input channel.
	Digital Output Mappable. Parameter can be mapped to a user digital output channel.

Figure 3-1: Parameter Symbols

3.1.1 General System Info Parameters

The following parameters contain version and setup information.

Parameter Name	Parameter #	Description
[FPGA Firmware V#]	101	Logic Firmware Version #
[DSP Firmware V#]	102	Processor Firmware Version #
[DSP Product Type]	103	Factory Product Code
[DSP kW Macro]	104	Firmware Build Kilowatt Level
[Parameter List V#]	105	Parameter List Version #
[WebUI Driver V#]	106	Web User Interface Driver Version #
[Applet V#]	107	Web User Interface Java Applet Version #
[LCD Menu V#]	108	Front Panel User Interface Menu List Version #

[LCD Product Type]	109	Factory Product Code
[LCD Driver V#]	110	Front Panel User Interface Firmware Version #
[Setup Wizard Done]	111	= 1 if user has completed Setup Wizard

Figure 3-2: Parameters containing version and set up information.

3.2 Front-Panel Interface

[\[LCD Display Param ID1\] . . . \[LCD Display Param ID20\]](#)

Selecting Runtime Data View from the main menu will take you to the Runtime Data Page, which displays a user-configurable list of system parameters at all times.

[LCD Display Param ID1] . . . [LCD Display Param ID20]	Parameter #	201 . . . 220
	Type	<input type="checkbox"/> Write-USER <input type="checkbox"/> CWR
	Range	[0 . . . Maximum Parameter ID]
	Default	0

These parameters determine which parameter values are displayed on the Runtime Data Page. **[LCD Display Param ID1]** contains the parameter ID for the parameter that the user wants to display on the first line of the Runtime Data. **[LCD Display Param ID2]** contains the parameter ID for the parameter on line 2, and so on up to line 20. Any valid parameter ID may be entered into these parameters.

3.3 MODBUS Interface

3.3.1 Introduction

The inverter allows the user to view and configure all system parameters using the Modbus interface over a serial hardware interface. The Modbus RTU protocol is an industrial communications and distributed control system to integrate PLCs, computers, terminals, and other monitoring, sensing, and control devices. Modbus is a Master-Slave communications protocol. The Master controls all serial activity by selectively polling one or more slave devices. The protocol provides for one master device and up to 247 slave devices on a common line. Each device is assigned an address to distinguish it from all other connected devices. More information on the protocol standard can be found here:

http://www.Modbus.org/docs/Modbus_Application_Protocol_V1_1a.pdf
http://www.Modbus.org/docs/Modbus_over_serial_line_V1.pdf

The system supports three different hardware protocols: RS-232, the standard RS-485 half-duplex multidrop, and the modified RS-485 full-duplex multidrop protocol. The user must configure the communication parameters to match those of the Modbus master controller. The user must also properly configure the hardware connection on the I/O board.

“All Modbus registers are 16-bit signed integers, however most of the parameters are floating point numbers. To obtain the actual floating point value of a parameter, it’s Modbus register value needs to be multiplied by the scale coefficient for that parameter. The scale coefficients of all parameters are provided in Appendix B (Parameter List) in the column “Scale”. For example, if a user reads a value of 5051 for Parameter 801 (Inverter AC Voltage) using Modbus, the actual value is $5051 \times 0.1 = 505.1V$.”

3.3.2 MODBUS Setup

3.3.2.1 MODBUS Parameter Configuration

[\[Device ID\]](#)

[\[Baud Rate\]](#)

[\[Data Bits\]](#)

[\[Parity\]](#)

[\[Stop Bits\]](#)

[\[RS-232/485 Select\]](#)

Both RS-232 and RS-485 (full-duplex or half-duplex) standards are supported. In RS-232 and RS-485 full-duplex, the transmitter is on continuously. In RS-485 half-duplex, the transmitter is only powered when the device being polled is transmitting. After setting the [\[RS-232/485 Select\]](#) to choose the protocol being used, the protocols require that you specify four parameters: the [\[Baud Rate\]](#) of the transmission, the number of [\[Data Bits\]](#) encoding a character, the sense of the optional [\[Parity\]](#), and the number of [\[Stop Bits\]](#). Each transmitted character is packaged in a character frame that consists of a single start bit followed by the data bits, the optional parity bit, and the stop bit or bits.

[Device ID]	Parameter #	301
	Type	Write-USER
	Range	[1 . . . 247]
	Default	1

If the user installs multiple Slave devices in a RS-485 Modbus chain, each Slave will require a unique [\[Device ID\]](#) so the Master can communicate with it. Only one Slave is possible using RS-232, so this parameter should be set to 1 when using RS-232.

[Baud Rate]	Parameter #	302
	Type	Write-USER
	Range	[4800 . . . 57600]
	Units	10 bps
	Default	38,400

[\[Baud Rate\]](#) is a measure of how fast data is moving between instruments that use serial communication. When setting this parameter, note that the units are 10 bps, not 1 bps, so if Modbus is used, the entered value should be the actual value divided by 10. If this parameter is configured using the keypad or Web Interface, the value should be entered without scaling.

[Data Bits]	Parameter #	303
	Type	Write-USER
	Range	7, 8
	Default	8

This is the number of bits transmitted per packet. Nearly all systems should be configured for 8 data bits.

[Parity]	Parameter #	304
	Type	Write-USER
	Range	0 No Parity 1 Odd Parity 2 Even Parity
	Default	0

An optional parity bit follows the data bits in the character frame. This bit is included as a simple means of error handling. It is typically disabled (no parity).

[Stop Bits]	Parameter #	305
	Type	Write-USER
	Range	1, 2
	Default	1

The last part of a character frame consists of 1 or 2 stop bits. 1.5 stop bits is not supported because this setting is only required if the port is configured for 5 data bits. Nearly all systems should be configured for 1 stop bit.

[RS-232/485 Select]	Parameter #	306
	Type	Write-USER
	Range	0 RS-232 1 RS-485
	Default	0

This parameter allows the user to select between RS-232 or RS-485 communication.

RS-232 Hardware Configuration

For RS-232, connect the following signals to J66 of the interface board:

RS-232 Signal Name	Pin #
TXD - Transmit	1
CTS - Clear to Send	2
RXD - Receive	3
RTS - Ready to Send	4
Signal Ground	5

Figure 3-3: J66 RS232 Signal Pin out

For RS-232, configure the piano switches located on the I/O board as follows:

Switch	Position	Comments
1	Down (OFF)	
2	Down (OFF)	
3	Down (OFF)	No termination resistor
4	Down (OFF)	
5	Down (OFF)	No termination resistor
6	Down (OFF)	
7	Down (OFF)	
8	Down (OFF)	

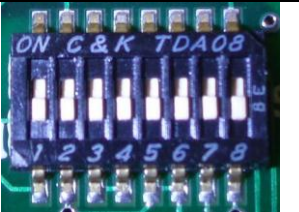

Figure 3-4: RS-232 Dip Switch Configuration

Half-Duplex RS-485 Hardware Configuration

RS-485 is a multidrop protocol, which means more than two systems can be connected. Devices are connected in a daisy chain or “bus”, which means that devices in the middle of the chain will have a pair of wires coming from the previous node and a pair of wires going to the next node. The devices at either end of the bus will have only one incoming pair and need to have signal termination installed.

Termination

If the inverter is the only slave device on the Modbus communication bus, or if it is physically located at either end of the bus, the communication signals must be terminated. There are two ways to accomplish this.

(1) *Termination without bias:* For basic termination using on-board 120 Ω, the user can configure the piano switches on the I/O board as shown in the table below. The termination capacitor may be removed by setting switch 4 in the Down (OFF) position.

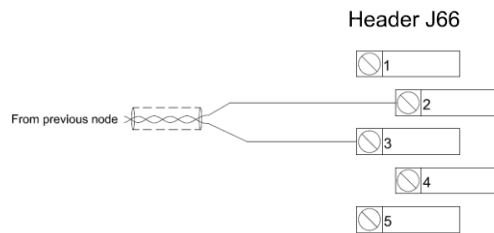

Switch	Position	Comments
1	Up (ON)	Shorts terminals 1 & 3
2	Up (ON)	Shorts terminals 2 & 4
3	Up (ON)	120 ohm termination
4	Up (ON)	Termination capacitor
5	Down (OFF)	
6	Down (OFF)	
7	Down (OFF)	
8	Down (OFF)	

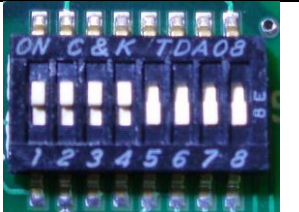

Figure 3-5: RS 485 Half Duplex Dip Switch settings no bias

(2) *Termination with bias:* For more robust termination with voltage bias, the user can configure the piano switches on the I/O board as shown in the table below. The termination capacitor may be removed by setting switch 4 in the Down (OFF) position.

Switch	Position	Comments
1	Up (ON)	Shorts terminals 1 & 3
2	Up (ON)	Shorts terminals 2 & 4
3	Up (ON)	120 ohm termination
4	Up (ON)	Termination capacitor
5	Down (OFF)	
6	Down (OFF)	
7	Up (ON)	Voltage bias
8	Up (ON)	Voltage bias

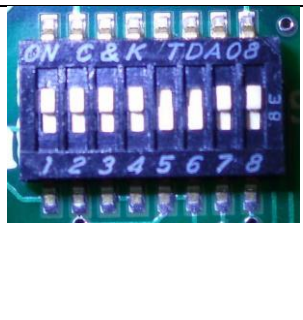

Figure 3-6: RS 485 Half Duplex Switch settings with bias

Multidrop Connection

The figure below shows a half-duplex RS-485 connection for a device that is not located at either end of the bus. One differential signal is used for both transmit and receive. This corresponds to two pairs of wires, with each pair consisting of a (+) and (-) wire. One pair comes from the preceding node and one pair goes to the next node in the bus. The following signal connections are required:

Header J66

Half-Duplex RS-485 Signal Name	Pin #
Negative (-)	1
Positive (+)	2
Negative (-)	3
Positive (+)	4
Signal GND	5

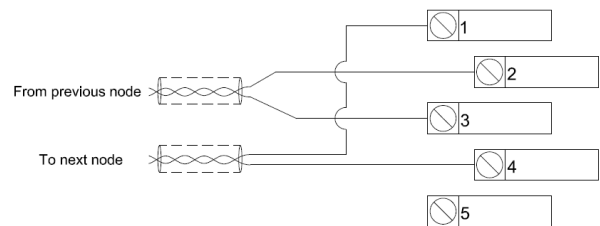

Figure 3-7: RS 485 Half Duplex Multidrop Configuration Pin out

If there are multiple slave devices on the Modbus communication bus and the inverter is not physically located at either end of the bus, then set the switches as follows:

Switch	Position	Comments
1	Up (ON)	Shorts terminals 1 & 3
2	Up (ON)	Shorts terminals 2 & 4
3	Down (OFF)	No termination resistor
4	Down (OFF)	No termination capacitor
5	Down (OFF)	
6	Down (OFF)	
7	Down (OFF)	
8	Down (OFF)	

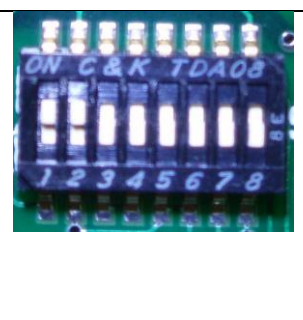

Figure 3-8: RS 485 Half Duplex multiple slave configuration dip switch settings

Full-Duplex RS-485 Hardware Configuration

Full-duplex RS-485 uses two differential signals, transmit and receive. This corresponds to four wires (TX+, TX-, RX+, RX-).

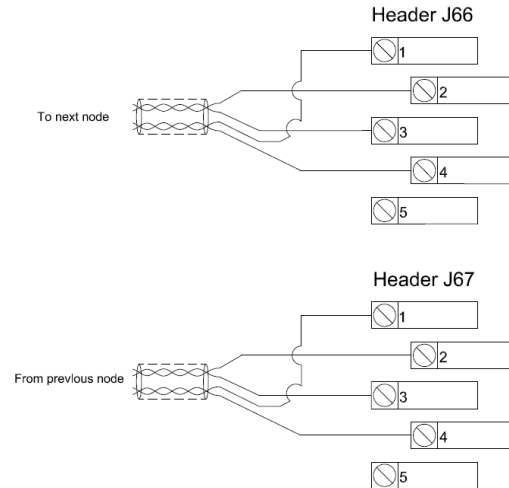

Figure 3-9: RS 485 Full Duplex Configuration

The following signal connections are required:

Full-Duplex RS-485 Signal Name	Pin #
Transmit (-)	1
Transmit (+)	4
Receive (-)	3
Receive (+)	2
Signal Ground	5

Figure 3-10: RS 485 Full Duplex pin configuration

If the inverter is the only slave device on the Modbus communication bus, or if it is physically located at either end of the bus, the communication signals must be terminated by setting the switches as follows:

Switch	Position	Comments
1	Down (OFF)	Separates terminals 1 & 3
2	Down (OFF)	Separates terminals 2 & 4
3	Up (ON)	120 ohm termination
4	Up (ON)	Termination capacitor
5	Up (ON)	120 ohm termination
6	Up (ON)	Termination capacitor
7	Down (OFF)	
8	Down (OFF)	

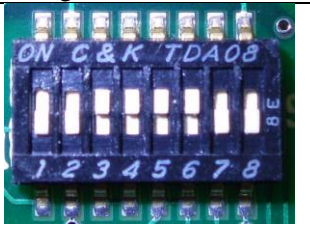

If the inverter is not physically located at either end of the bus, set all switches to Down (OFF) position.

Figure 3-11: RS 485 Full Duplex slave dip switch settings

Supported MODBUS Functions

The following Modbus functions are supported and provide the functionality necessary to monitor and control the inverter remotely.

Function Code	Description
03 (0x03)	Read Holding Registers
04 (0x04)	Read Input Registers
06 (0x06)	Write Single Register
16 (0x10)	Write Multiple Registers
23 (0x17)	Read/Write Multiple Registers

Figure 3-12: Supported Modbus Functions

Message Format

Address	Function Code	Data	Error Check
---------	---------------	------	-------------

The address field of a message frame contains 8 bits. Each slave device is assigned a unique address in the range of 1 – 247. Master can communicate with any slave by inserting the appropriate address into the address field. Also master can broadcast a message to all the slaves connected to the network by placing 0 into the address field. When slave responds, it places its address into the address field of a response message, to indicate which slave responded.

The function code field of a message frame contains eight bits. Valid codes are in the range of 1-255 decimal (0x00 to 0xFF hexadecimal). When a message is sent from a master to a slave device the function code field tells the slave what kind of action to perform.

When the slave responds to the master, it uses the function code field to indicate either a normal (error-free) response or that some kind of error occurred (called an exception response). For a normal response, the slave simply echoes the original function code. For an exception response, the slave returns a code that is equivalent to the original function code with its most significant bit set to a logic 1.

The data field is constructed using sets of two hexadecimal digits (one RTU character), in the range of 00 to FF hexadecimal. The data field of messages sent from a master to slave devices contains additional information which the slave must use to take the action defined by the function code. This can include items like discrete and register addresses, the quantity of items to be handled, and the count of actual data bytes in the field.

In the inverter, Modbus Register addresses (which start at 0) match Parameter IDs (which start at 1), so Register 0 corresponds to a Parameter ID of 1.

If no error occurs, the data field of a response from a slave to a master contains the data requested. If an error occurs, the field contains an exception code that the master application can use to determine the next action to be taken.

The message also contains a 16-bit checksum at the end of the packet for error checking.

Read Registers - 03 (0x03) & 04 (0x04)

These function codes are used to read the contents of one or more sequential registers. Because the holding and input registers share the same memory space, they can be used interchangeably. The request specifies the starting register address and the number of registers. The response contains the sequential data read from the registers.

Request

Function Code	1 byte	0x03 or 0x04
Starting Address	2 bytes	0x0000 to 0xFFFF
Number of Registers to Read (N)	2 bytes	1 to 125 (0x0001 to 0x007D)

Response

Function Code	1 byte	0x03
Byte Count	1 byte	2 x N
Register Values	N x 2 bytes	[data]

Error

Error Code	1 byte	0x83 or 0x84
Exception Code	1 byte	01, 02, 03, or 04

Write Single Register - 06 (0x06)

This function code is used to write a single register. The request specifies the target register address. The normal response is an echo of the request after the register contents have been written.

Request

Function Code	1 byte	0x06
Register Address	2 bytes	0x0000 to 0xFFFF
Register Data	2 bytes	0x0000 to 0xFFFF

Response

Function Code	1 byte	0x06
Register Address	2 bytes	0x0000 to 0xFFFF
Register Data	2 bytes	0x0000 to 0xFFFF

Error

Error Code	1 byte	0x86
Exception Code	1 byte	01, 02, 03, or 04

Write Multiple Registers - 16 (0x10)

This function code is used to write to one or more sequential registers, up to 120 registers. The response contains the function code, starting address, and number of registers written.

Request

Function Code	1 byte	0x10
Starting Address	2 bytes	0x0000 to 0xFFFF
Number of Registers to Write (N)	2 bytes	1 to 120 (0x0001 to 0x00078)
Byte Count	1 byte	2 x N
Register Values	N x 2 bytes	[data]

Response

Function Code	1 byte	0x10
Starting Address	2 bytes	0x0000 to 0xFFFF
Number of Registers Written	2 bytes	1 to 120 (0x0001 to 0x00078)

Error

Error Code	1 byte	0x90
Exception Code	1 byte	01, 02, 03, or 04

Read/Write Multiple Registers - 23 (0x17)

This function code is used to write to one or more sequential registers and then, in the same function call, read one or more sequential register values. This can be used to automatically confirm the register settings after a write. The request specifies the read starting address, number of registers to be read, write starting address, number of registers to be written, and the data to be written. The byte count specifies the number of bytes in the write data field. The response contains the data from the group of registers that were read. The byte count field specifies the number of bytes in the read data field.

Request

Function Code	1 byte	0x17
Read Starting Address	2 bytes	0x0000 to 0xFFFF
Number of Registers to Read	2 bytes	1 to 118 (0x0001 to 0x0076)
Write Starting Address	2 bytes	0x0000 to 0xFFFF
Number of Registers to Write (N)	2 bytes	1 to 118 (0x0001 to 0x0076)
Write Byte Count	1 byte	2 * N
Register Values	N x 2 bytes	[data]

N = Registers written

Response

Function Code	1 byte	0x10
Read Byte Count	2 bytes	1 to 236 (0x0001 to 0x00EC)
Read Register Values	N x 2 bytes	[data]

N = Registers read

Error

Error Code	1 byte	0x97
Exception Code	1 byte	01, 02, 03, or 04

Web Interface

[\[IP Address MSB\]... \[IP Address LSB\]](#)

[\[Subnet Mask MSB\]... \[Subnet Mask LSB\]](#)

[\[Gateway MSB\]... \[Gateway LSB\]](#)

[\[E-mail Trip Data Enable\]](#)

Web User Interface Setup

Note: To use the Web Interface, the user must install Java Runtime Environment version 5.0 (or newer) on the computer workstation. This can be done by visiting <http://java.com/en/download/index.jsp>, for instructions, and for downloading, and installing the Java software.

An optional external RJ-45 Ethernet jack, with a weather-seal cap, can be located on top of the enclosure roof to allow for easy connection to a Local Area Network (LAN). The internal connection of this Ethernet port is routed to an RJ-45 jack on the system Control Board located on the inside left side of the enclosure Figure 3-14: Ethernet Jack Location

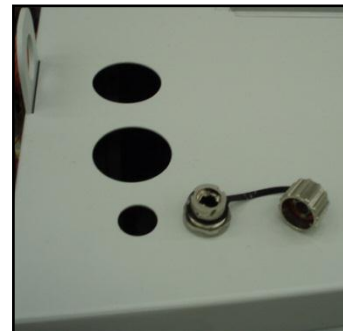

RJ-45

Figure 3-13: Optional External Ethernet Jack

Note: If a user is connecting directly between the RJ-45 jack of a local computer and the inverter RJ-45 jack, without the use of a network connection, router, or switch (etc.), an Ethernet “Crossover” cable may be required for proper communication.

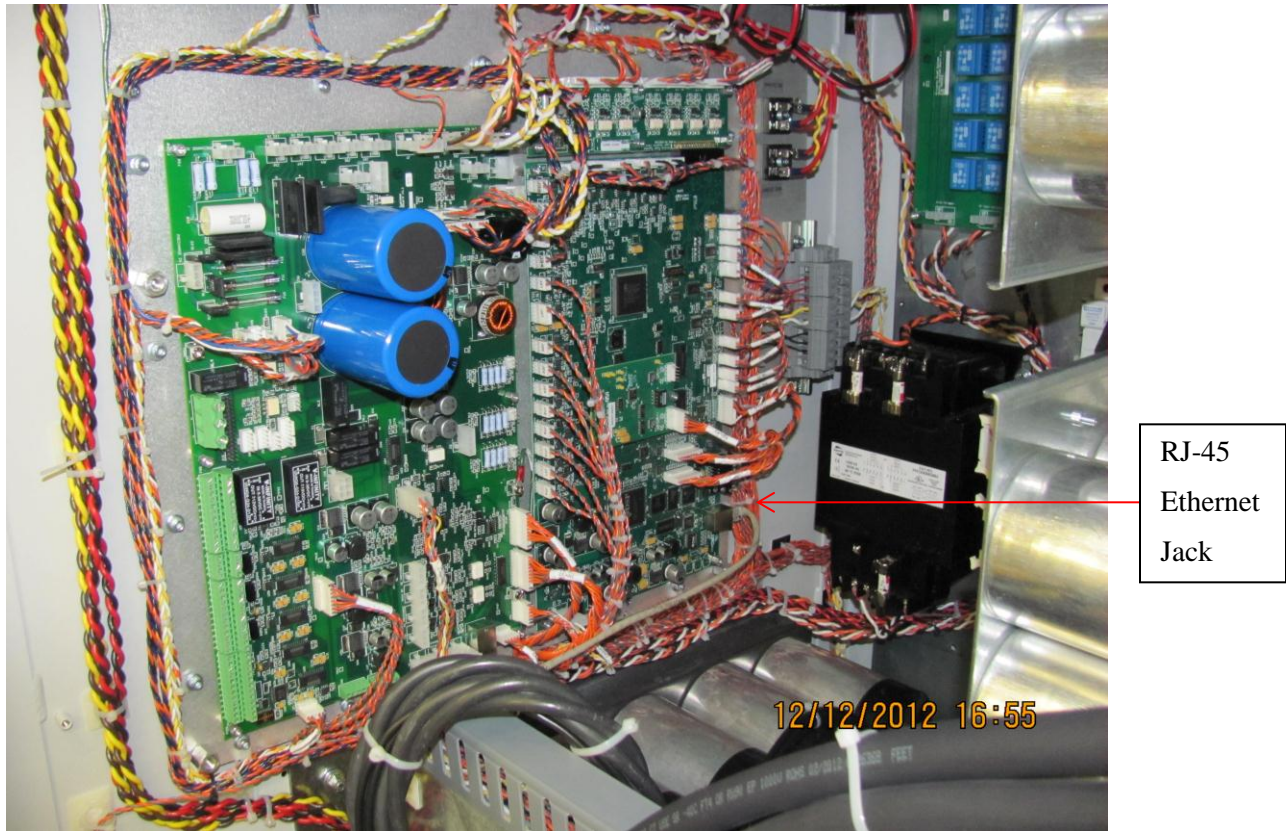

Figure 3-14: Ethernet Jack Location

The user should verify that an Ethernet cable is plugged into the inverter's control board (shown above) and into an active Ethernet jack. Open up a web browser (e.g. Internet Explorer) after the software has been installed on the computer workstation. Type the inverter's Host Name (the default is *BIGI+Serial Number*, e.g. *BIGI123*) into the web browser's address. If the browser first displays a security warning before displaying the Web Interface page, grant security access. This is usually done by right-clicking the security warning and selecting "Allow Blocked Content. . .".

It will take the Web Interface's Java applet a few seconds to load before displaying a login page. The default login username is **user** and default password is **user**. After logging in for the first time, the user should change the username and password from the "Change Password" menu.

If multiple inverters are installed on the same network, the user must take care to not have two inverters on the network with the same Host Name. Doing so will prevent Web Interface access on all inverters with identical Host Names. Make sure to change the Host Name via the Inverter Configuration/WebUI menu on the inverter before plugging additional units into the network.

Features

The Web Interface has the following features:

Step-by-step **Setup Wizard** for initial installation of the inverter, configuration of the analog & digital inputs/outputs, and setup & auto-tuning of motor parameters.

Configuration and viewing of all system parameters via the **Inverter Configuration** menu.

Run/stop control and continuous real-time viewing of system status parameters via the **Inverter Status** menu.

Back-up/Saving and reloading of parameter profiles via the **Save/Load Profile** menu.

Web Interface Parameters

[DHCP Enable]	Parameter #	401
	Type	Write-USER
	Range	0 DHCP service disabled 1 DHCP service enabled
	Default	1

If the DHCP service is enabled, the IP Address, Subnet Mask, and Gateway are set automatically and the inverter's Host Name is used to access the Web Interface. If the DHCP service is disabled, the user must configure the IP Address, Subnet Mask, and Gateway based on his network's settings. The Host Name can only be viewed and modified from the Web Interface, not from the Front Panel or Modbus interfaces.

[IP Address MSB] [IP Address Byte 3] [IP Address Byte 2] [IP Address LSB]	Parameter #	402 . . . 405
	Type	Write-USER
	Range	[0 . . . 255]
	Default	192.168.0.200

Only modify this value if **[DHCP Enable]** is 0. The IP address should be chosen such that it is unique on the network. Typically MSB, Byte 3, and Byte 2 are the same as the corresponding Gateway values, but it depends on the network setup. Please consult the network administrator on how to set up these parameters

[Subnet Mask MSB] [Subnet Mask Byte 3] [Subnet Mask Byte 2] [Subnet Mask LSB]	Parameter #	406 . . . 409
	Type	Write-USER
	Range	[0 . . . 255]
	Default	255.255.255.0

Only modify this value if **[DHCP Enable]** is 0. This four-parameter setting should be the same as the Subnet Mask on another PC on the network.

[Gateway MSB] [Gateway Byte 3] [Gateway Byte 2] [Gateway LSB]	Parameter #	410 . . . 413
	Type	Write-USER
	Range	[0 . . . 255]
	Default	192.168.0.1

Only modify this value if **[DHCP Enable]** is 0. This four-parameter setting should be the same as the Gateway on another PC on the network.

[E-mail Trip Data Enable]	Parameter #	414
	Type	<input type="checkbox"/> Write-USER <input type="checkbox"/> CWR
	Range	0 Trip data email disabled 1 Trip data email enabled
	Default	0

If the trip data email is enabled, the inverter will send an email message with trip information to the email address configured by the manufacturer. This is used for gathering trip information by the manufacturer to provide fast technical support and to improve the performance of the inverter. The destination email address cannot be changed by a user. Disable this parameter only if the inverter is not connected to the Internet.

Password Protection

Password Protection Setup

[\[Password\]](#)

[\[User Set Password\]](#)

Some of the system parameters are password protected, and cannot be edited unless a password with sufficient access is entered. There are three levels of access:

Open Access – Operational parameters modifiable by all users.

User Access – Parameters configurable by the facility manager configuration.

Factory Access – Parameters used for system commissioning and testing, accessible by authorized installation and field service technicians.

The default user-level password is **000**. Note that this is different than the Web Interface password. For security reasons, the customer should consider changing the **[User Set Password]** from the default value after logging in for the first time. Until the user changes the user-level password to something other than “000”, all user-level access parameters will be accessible by all users. Write down this new password and store it in a safe place. Lost passwords will require reinitializing the inverter system, which can be done only by a qualified service technician.

Password Protection Parameters

In general, once user-level access has been granted, the user can change the user-level password.

[Password]	Parameter #	501
-------------------	-------------	-----

	Type	<input type="checkbox"/> Write-OPEN <input checked="" type="checkbox"/> Read <input type="checkbox"/> CWR
	Range	[0 . . . 32767]
	Default	0

In order to gain access to parameters protected by the user-settable password, enter the user password into this parameter. If the entered value matches the stored **[User Set Password]**, you will be granted access to the protected parameters.

[User Set Password]	Parameter #	502
	Type	<input type="checkbox"/> Write-USER <input checked="" type="checkbox"/> Read <input type="checkbox"/> CWR
	Range	[0 . . . 32767]
	Default	0

Store a password of your choice in this parameter. After this password is changed from its default, the user must log in by entering the new password in the **[Password]** parameter.

[Factory Set Password]	Parameter #	503
	Type	<input checked="" type="checkbox"/> Write-FACTORY <input checked="" type="checkbox"/> Read <input type="checkbox"/> CWR
	Range	[0 . . . 32767]
	Default	314

Inverter Configuration Parameters

[\[Inverter Control Mode\]](#)

[\[Inverter Grid Mode\]](#)

[\[Auto Grid Contactor Control Enable\]](#)

[\[Manual Grid Contactor On\]](#)

[Inverter Control Mode]	Parameter #	601
	Type	<input type="checkbox"/> Write-USER
	Range	0 Battery Port Control Mode 1 Grid Port Control Mode (Grid Support Mode)
	Default	1

Setting this parameter to **0** will set the system to control the Battery port power. Parameter **[Power Command]** will control the power exported/imported by the Battery port.

Setting this parameter to **1** will set the system to control the Grid port power. Parameter **[Power Command]** will control the power exported/imported by the Grid port.

[Inverter Grid Mode]	Parameter #	603
-----------------------------	-------------	-----

	Type	Write-USER
	Range	0 Automatic 1 On-grid 2 Off-grid
	Default	1

This parameter specifies the mode of operation for the grid port: automatic, on-grid, or off-grid. If this parameter is set to **0 (Automatic)**, the grid port will run in either on-grid or off-grid mode based on the status of the optional external grid contactor. If the contactor is closed, the system automatically changes to on-grid mode; if the contactor is open, the system automatically changes to off-grid mode.

If this parameter is set to **1 (On-grid)**, the system will always run in on-grid mode and if it is set to **2 (off-grid)**, the system will always run in off-grid mode.

[Auto Grid Contactor Control Enable]	Parameter #	604
	Type	Write-USER
	Range	0 Disable 1 Enable
	Default	0

This parameter specifies the way the optional grid contactor is controlled. If the parameter is set to **1**, the grid contactor is controlled based on the remote grid voltage measurements. If the grid voltage is within the limits specified by IEEE1547, the grid contactor will be closed. The contactor can be controlled manually by setting this parameter to **0** and using **[Manual Grid Contactor On]** parameter.

[Manual Grid Contactor On]	Parameter #	605
	Type	Write-USER
	Range	0 Grid Contactor Off 1 Grid Contactor On
	Default	1

This parameter controls the state of the optional external grid contactor if it is in the manual control mode. Setting this parameter to 1 will turn the contactor on and setting it to 0 will turn the contactor off. The inverter needs to be synchronized to the AC source before the contactor is commanded to close.

[Reactive Power Control Enable]	Parameter #	608
	Type	Write-FACTORY
	Range	0 Disable 1 Enable
	Default	1

Setting this parameter to 1 will enable controlling the reactive power of the inverter using the parameter **[Reactive Power Command]**. Setting this parameter to 0 will disable controlling the reactive power and automatically will set **[Reactive Power Command]** to 0. This parameter is factory password protected and cannot be set by a user.

Inverter Control Parameters

[\[Inverter On\]](#)

[\[Inverter Reset\]](#)

[\[Battery Port Enable\]](#)

[\[PV Port Enable\]](#)

[\[Grid Port Enable\]](#)

[\[Power Command\]](#)

[\[Reactive Power Command\]](#)

[\[Power Command Analog Lo\]](#)

[\[Power Command Analog Hi\]](#)

[\[Run On Power Up\]](#)

[\[Pulse Limit\]](#)

[Inverter On]	Parameter #	701
	Type	<input checked="" type="checkbox"/> Write-OPEN <input type="checkbox"/> CWR <input type="radio"/> DIn <input type="radio"/> DOut
	Range	[0, 1]
	Default	0

Setting this parameter to 1 will start the inverter as long as **[Inverter Reset]** is not set to 1. Resetting this parameter to 0 will stop the inverter. Changing this parameter from 1 to 0 will act as a system reset, and will clear system faults. Digital inputs can be mapped to this parameter so it may be controlled by a remote system. At list one port needs to be enabled for the inverter to start.

[Inverter Reset]	Parameter #	702
	Type	<input checked="" type="checkbox"/> Write-OPEN <input type="checkbox"/> CWR <input type="radio"/> DIn
	Range	[0, 1]
	Default	0

Changing this parameter from 0 to 1 acts as a system reset, and will clear system faults. A digital input can be mapped to this parameter so it may be controlled by a remote system.

[Battery Port Enable]	Parameter #	703
	Type	<input checked="" type="checkbox"/> Write-OPEN <input type="checkbox"/> CWR <input type="radio"/> DIn
	Range	[0, 1]
	Default	0

Setting this parameter to 1 will enable the Battery port.

[PV Port Enable]	Parameter #	704
	Type	<input checked="" type="checkbox"/> Write-OPEN <input type="checkbox"/> CWR <input type="radio"/> DIn
	Range	[0, 1]
	Default	0

Setting this parameter to 1 will enable the PV port.

[Grid Port Enable]	Parameter #	705
---------------------------	-------------	-----

	Type	<input type="checkbox"/> Write-OPEN <input type="checkbox"/> CWR <input type="radio"/> DIn
	Range	[0, 1]
	Default	0

Setting this parameter to 1 will enable the Grid port.

[Power Command]	Parameter #	706
	Type	<input type="checkbox"/> Write-OPEN <input type="checkbox"/> CWR <input type="radio"/> AIn <input type="radio"/> AOut
	Range	[-250. . . 250]
	Units	kW
	Default	0

This parameter controls the amount of real power that is exported or imported from the inverter on the AC grid port or on the Battery port. If **[Inverter Control Mode]** is set to 0 (Battery Port Control), **[Power Command]** controls the amount of power exported or imported on the Battery port. If **[Inverter Control Mode]** is set to 1 (Grid Port Control), **[Power Command]** controls the amount of power exported or imported on the Grid port. If the Battery port is disabled, this parameter has no effect on the operation of the inverter. In this case, inverter will export the maximum power from the PV array.

[Reactive Power Command]	Parameter #	707
	Type	<input type="checkbox"/> Write-OPEN <input type="checkbox"/> CWR <input type="radio"/> AIn <input type="radio"/> AOut
	Range	[-250. . . 250]
	Units	kVar
	Default	0

This parameter controls the amount of reactive power that is exported from the inverter on the AC grid port. Positive value indicates capacitive reactive power and negative value indicates inductive reactive power. This parameter only has an effect if **[Reactive Power Control Enable]** set to 1 by the factory.

[Power Command Analog Lo]	Parameter #	708
	Type	<input type="checkbox"/> Write-USER
	Range	[-250. . . 250]
	Default	0
[Power Command Analog Hi]	Parameter #	709
	Type	<input type="checkbox"/> Write-USER
	Range	[-250. . . 250]
	Default	250

These parameters are the analog mapping parameters for **[Power Command]** and **[Reactive Power Command]**. See Section 0.

[Run On Power Up]	Parameter #	710
--------------------------	-------------	-----

	Type	<input type="checkbox"/> Write-USER <input type="checkbox"/> CWR
	Range	0 Disabled 1 Enabled
	Default	0

If this parameter is set to 1, then the inverter will automatically self-initiate a standard start command immediately when power is applied to the input terminals, provided that the right signals are present. In order to start, the **[Inverter On]** parameter must be a 1. **[Inverter Reset]** must be 0.

Inverter Monitoring Parameters

The system parameters in this section serve to provide information about the operation of the inverter. Many system measurements are available to be monitored

[Grid AC Voltage AB]	[Battery Voltage Analog Lo]
[Grid AC Voltage BC]	[Battery Voltage Analog Hi]
[Grid AC Voltage CA]	[Battery Current]
[Inverter AC Voltage Analog Lo]	[Battery Current Analog Lo]
[Inverter AC Voltage Analog Hi]	[Battery Current Analog Hi]
[Inverter AC Voltage]	[Battery Power]
[Grid AC Voltage Analog Lo]	[Battery Power Analog Lo]
[Grid AC Voltage Analog Hi]	[Battery Power Analog Hi]
[Inverter AC Current]	[Battery State of Charge]
[Inverter AC Current Analog Lo]	[PV Voltage]
[Inverter AC Current Analog Hi]	[PV Voltage Analog Lo]
[Grid AC Power Real]	[PV Voltage Analog Hi]
[Grid AC Power Reactive]	[PV Current]
[AC Power Analog Lo]	[PV Current Analog Lo]
[AC Power Analog Hi]	[PV Current Analog Hi]
[AC Bridge Current]	[PV Power]
[AC Bridge Current Analog Lo]	[PV Power Analog Lo]
[AC Bridge Current Analog Hi]	[PV Power Analog Hi]
[Battery Voltage]	[Central Cap Voltage]
	[Frequency Command]

[Grid AC Voltage AB]	Parameter #	801... 803
[Grid AC Voltage BC]	Type	<input type="checkbox"/> Read-Only <input type="checkbox"/> AOut
[Grid AC Voltage CA]	Range	[0... 1000]
	Units	V
	Default	0

3 Individual RMS phase-to-phase voltages on the terminals of the AC grid port.

[Grid AC Voltage Analog Lo]	Parameter #	804
------------------------------------	-------------	-----

	Type	Write-USER
	Range	[0. . . 3200]
	Default	0
[Grid AC Voltage Analog Hi]	Parameter #	805
	Type	Write-USER
	Range	[0. . . 3200]
	Default	1000

These parameters are the analog mapping parameters for **[Grid AC Voltage AB]**, **[Grid AC Voltage BC]**, and **[Grid AC Voltage CA]**.

[Inverter AC Voltage]	Parameter #	806
	Type	Read-Only AOut
	Range	[0. . . 1000]
	Units	V
	Default	0

The average of the 3 RMS output voltages of the inverter.

[Inverter AC Voltage Analog Lo]	Parameter #	807
	Type	Write-USER
	Range	[0. . . 3200]
[Inverter AC Voltage Analog Hi]	Parameter #	808
	Type	Write-USER
	Range	[0. . . 3200]
	Default	1000

These parameters are the analog mapping parameters for **[Inverter AC Voltage]**.

[Inverter AC Current]	Parameter #	809
	Type	Read-Only AOut
	Range	[0. . . 500]
	Units	Amps
	Default	0

The average of the 3 RMS output currents of the inverter.

[Inverter AC Current Analog Lo]	Parameter #	810
	Type	Write-USER
	Range	[0. . . 3200]
[Inverter AC Current Analog Hi]	Parameter #	811
	Type	Write-USER
	Range	[0. . . 3200]
	Default	200

These parameters are the analog mapping parameters for **[Inverter AC Current]**.

[Inverter AC Power Real]	Parameter #	812
	Type	Read Only AOut
	Range	[-300. . . 300]
	Units	KW
	Default	0

Real AC power exported/imported on the Grid port. Positive value indicates the power is being exported into the grid. Negative value indicates the power is being imported from the grid

[Inverter AC Power Reactive]	Parameter #	813
	Type	Read Only AOut
	Range	[-300. . . 300]
	Units	KVar
	Default	0

Reactive AC power output of the inverter. Positive value indicates capacitive reactive power and negative value indicates inductive reactive power.

[AC Power Analog Lo]	Parameter #	814
	Type	Write-USER
	Range	[-320. . . 320]
	Default	0
[AC Power Analog Hi]	Parameter #	815
	Type	Write-USER
	Range	[-320. . . 320]
	Default	100

These parameters are the analog mapping parameters for **[Inverter AC Power Real]** and **[Inverter AC Power Reactive]**.

[AC Bridge Current]	Parameter #	816
	Type	Read Only AOut
	Range	[0. . . 1000]
	Units	Amps
	Default	0

The average of the 3 RMS currents at the three phase terminals of the internal switching stage of the inverter.

[AC Bridge Current Analog Lo]	Parameter #	817
	Type	Write-USER
	Range	[0. . . 3200]
	Default	0
[AC Bridge Current Analog Hi]	Parameter #	818

	Type	Write-USER
	Range	[0 . . 3200]
	Default	200

These parameters are the analog mapping parameters for **[AC Bridge Current]**.

[Battery Voltage]	Parameter #	819
	Type	Read-Only AOut
	Range	[0 . . 1000]
	Units	V
	Default	0

Voltage measured at the terminals of the Battery port.

[Battery Voltage Analog Lo]	Parameter #	820
	Type	Write-USER
	Range	[0 . . 3200]
	Default	0
[Battery Voltage Analog Hi]	Parameter #	821
	Type	Write-USER
	Range	[0 . . 3200]
	Default	1000

These parameters are the analog mapping parameters for **[Battery Voltage]**.

[Battery Current]	Parameter #	822
	Type	Read-Only AOut
	Range	[-1000 . . 1000]
	Units	Amps
	Default	0

Current measured at the terminals of the Battery port. Positive value indicates the current is flowing from the battery into the inverter. Negative value indicates the current is flowing from the inverter into the battery.

[Battery Current Analog Lo]	Parameter #	823
	Type	Write-USER
	Range	[0 . . 3200]
	Default	0
[Battery Current Analog Hi]	Parameter #	824

	Type	Write-USER
	Range	[0. . . 3200]
	Default	200

These parameters are the analog mapping parameters for **[Battery Current]**.

[Battery Power]	Parameter #	825
	Type	Read Only AOut
	Range	[-300. . . 300]
	Units	kW
	Default	0

Power exported/imported on the Battery port. Positive value indicates the power is flowing from the battery into the inverter. Negative value indicates the power is flowing from the inverter into the battery.

[Battery Power Analog Lo]	Parameter #	826
	Type	Write-USER
	Range	[-3200. . . 3200]
	Default	0
[Battery Power Analog Hi]	Parameter #	827
	Type	Write-USER
	Range	[-3200. . . 3200]
Default	0	

These parameters are the analog mapping parameters for **[Battery Power]**.

[Battery State of Charge]	Parameter #	828
	Type	Read Only
	Range	[0. . . 100]
	Units	%
	Default	0

Battery State of Charge in percent.

[PV Voltage]	Parameter #	829
	Type	Read Only AOut
	Range	[0. . . 1000]
	Units	V
	Default	0

Voltage measured at the terminals of the PV port.

[PV Voltage Analog Lo]	Parameter #	830
	Type	Read Only AOut
	Range	[0. . . 3200]
	Units	V
Default	0	
[PV Voltage Analog Hi]	Parameter #	831

	Type	Read Only AOut
	Range	[0. . . 3200]
	Units	V
	Default	0

These parameters are the analog mapping parameters for **[PV Voltage]**.

[PV Current]	Parameter #	832
	Type	Read Only AOut
	Range	[0. . . 1000]
	Units	Amps
	Default	0

Current measured at the terminals of the Battery port.

[PV Current Analog Lo]	Parameter #	833
	Type	Read Only AOut
	Range	[0. . . 3200]
	Units	Amps
	Default	0
[PV Current Analog Hi]	Parameter #	834
	Type	Read Only AOut
	Range	[0. . . 3200]
	Units	Amps
	Default	0

These parameters are the analog mapping parameters for **[PV Current]**.

[PV Power]	Parameter #	835
	Type	Read Only AOut
	Range	[-300. . . 300]
	Units	KW
	Default	0

Power exported from the PV port.

[PV Power Analog Lo]	Parameter #	836
	Type	Write-USER
	Range	[-320. . . 320]
	Default	0
[PV Power Analog Hi]	Parameter #	837
	Type	Write-USER
	Range	[-320. . . 320]
	Default	100

These parameters are the analog mapping parameters for **[PV Power]**.

[Central Cap Voltage]	Parameter #	838
------------------------------	-------------	-----

	Type	Read Only AOut
	Range	[0. . . 3200]
	Units	V
	Default	0

Voltage on the central bus capacitor.

[Frequency Command]	Parameter #	839
	Type	Read Only AOut
	Range	[0. . . 320]
	Units	Hz
	Default	0

Internal frequency command of the grid port.

PV Control Setting Parameters

[\[PV Array Open Circuit Voltage\]](#)

[\[PV kWh Today\]](#)

[\[Reset kWh Today\]](#)

[\[PV Total kWh\]](#)

[\[PV Total MWh\]](#)

[\[Reset Total kWh\]](#)

[\[PV Total kWh\]](#)

[\[PV Total MWh\]](#)

[\[Reset Total kWh\]](#)

[\[Reset Date MMDD\]](#)

[\[Reset Date YY\]](#)

[PV Array Open Circuit Voltage]	Parameter #	910
	Type	Write-USER
	Range	[0. . . 3200]
	Units	V
	Default	580

Program the total open circuit voltage of the PV array in this parameter. The open circuit voltage of the array is the sum of the open circuit voltages of each PV module/panel in one of the array strings.

System design note: This inverter is most efficient at higher DC voltages. The array should be designed for the maximum allowable open circuit voltage that is less than or equal to 600VDC.

[PV kWh Today]	Parameter #	911
	Type	Read Only
	Range	[0. . . 32000]
	Units	kWh
	Default	0

Total number of kWh generated by the PV source so far in the present day.

[Reset kWh Today]	Parameter #	912
--------------------------	-------------	-----

	Type	Write-USER
	Range	[0,1]
	Default	0

Set this parameter to a 1 in order to reset the accumulated kWh in the **[PV kWh Today]** parameter. [Reset kWh Today] will automatically reset itself back to 0.

[PV Total kWh]	Parameter #	913
	Type	Read Only
	Range	[0. . . 999]
	Units	kWh
	Default	0

Total number of kWh generated by the PV source so far since the last full MWh was produced.

[PV Total MWh]	Parameter #	914
	Type	Read Only
	Range	[0. . . 32000]
	Default	0

Total number of MWh generated by the PV source so far since the last time this counter was reset.

[Reset Total kWh]	Parameter #	915
	Type	Write-USER
	Range	[0,1]
	Default	0

Set this parameter to 1 in order to reset the **[PV Total MWh]** and **[PV Total kWh]** parameters to zero. It will automatically reset itself back to 0.

[Reset Date MMDD]	Parameter #	916
	Type	Read Only
	Range	[0. . . 32000]
[Reset Date YY]	Default	0
	Parameter #	917
	Type	Read Only
	Range	[0. . . 32000]
	Default	0

These parameters document the date of the last time the **[PV Total MWh]** and **[PV Total kWh]** parameters were reset.

Battery Control Setting Parameters

[\[Bulk Charging Voltage\]](#)
[\[Float Charging Voltage\]](#)
[\[Maximum Charging Current\]](#)
[\[Bulk to Float Transition Current\]](#)
[\[Battery Charged Current\]](#)

[\[Battery Temperature\]](#)
[\[Battery Temp Analog Lo\]](#)
[\[Battery Temp Analog Hi\]](#)
[\[Temperature Compensation Enable\]](#)
[\[Temperature Compensation Per Cell\]](#)

[\[Battery Not Charged Voltage\]](#)
[\[Minimum Discharge Voltage\]](#)
[\[Battery Equalization Enable\]](#)
[\[Battery Equalization Voltage\]](#)
[\[Battery Equalization Time Hours\]](#)
[\[Battery Equalization Time Minutes\]](#)
[\[Bulk Delay Time Hours\]](#)
[\[Bulk Delay Time Minutes\]](#)

[\[Number of Cells\]](#)
[\[Bulk Time Out\]](#)
[\[Battery Minimum Voltage Limit\]](#)
[\[Battery Charging Voltage Limit\]](#)
[\[Generator On Command\]](#)
[\[Generator On Voltage\]](#)
[\[Generator Off Voltage\]](#)
[\[Maximum Discharging Current\]](#)

[Bulk Charging Voltage]	Parameter #	1001
	Type	<input type="checkbox"/> Write-USER <input type="checkbox"/> CWR
	Range	[250. . . 600]
	Units	V
	Default	568

This voltage is maintained in the Bulk charging stage

[Float Charging Voltage]	Parameter #	1002
	Type	<input type="checkbox"/> Write-USER <input type="checkbox"/> CWR
	Range	[250. . . 600]
	Units	V
	Default	540

This voltage is maintained in the Float charging stage

[Maximum Charging Current]	Parameter #	1003
	Type	<input type="checkbox"/> Write-USER <input type="checkbox"/> CWR
	Range	[0. . . 650]
	Units	A
	Default	40

Charging current limited to this value in all charging stages.

[Bulk to Float Transition Current]	Parameter #	1004
	Type	<input type="checkbox"/> Write-USER <input type="checkbox"/> CWR
	Range	[0. . . 650]
	Units	A
	Default	10

Unless *Bulk Delay Time* has not been reached yet, when charging current falls below **[Bulk to Float Transition Current]** the charging state changes to Float.

[Battery Charged Current]	Parameter #	1005
	Type	<input type="checkbox"/> Write-USER <input type="checkbox"/> CWR
	Range	[0. . . 650]
	Units	A
	Default	3

The charging state will change to Idle when the charging current has fallen below this value.

[Battery Not Charged Voltage]	Parameter #	1006
	Type	<input type="checkbox"/> Write-USER <input type="checkbox"/> CWR
	Range	[250. . . 600]
	Units	V
	Default	520

The charging state will return to Float from Idle when the battery voltage has discharged below this value.

[Minimum Discharge Voltage]	Parameter #	1007
	Type	<input type="checkbox"/> Write-USER <input type="checkbox"/> CWR
	Range	[200. . . 600]
	Units	V
	Default	400

The system will shut down and stop drawing power from the battery once the battery voltage reaches this value. The system must be switched to charge mode (by setting **[Power Command]** to a negative value) briefly before it will draw power from the battery again.

[Battery Equalization Enable]	Parameter #	1009
	Type	<input type="checkbox"/> Write-USER
	Range	[0,1]
	Default	0

Setting this parameter to “1” will initialize the battery equalization function the next time the system is switched to charge mode.

[Battery Equalization Voltage]	Parameter #	1010
	Type	<input type="checkbox"/> Write-USER
	Range	[250. . . 600]
	Units	V
	Default	576

This voltage is maintained during the equalization time.

[Battery Equalization Time Hours]	Parameter #	1011
	Type	<input type="checkbox"/> Write-USER
	Range	[0. . . 3600]
	Default	0
[Battery Equalization Time Minutes]	Parameter #	1012
	Type	<input type="checkbox"/> Write-USER
	Range	[0. . . 60]
	Default	0

The equalization voltage is maintained for **[Battery Equalization Time Minutes] + [Battery Equalization Time Hours]** before the system switches to the normal charging profile.

[Bulk Delay Time Hours]	Parameter #	1013
	Type	Write-USER
	Range	[0 . . 3600]
	Default	0
[Bulk Delay Time Minutes]	Parameter #	1014
	Type	Write-USER
	Range	[0 . . 60]
	Default	0

The charging state will remain Bulk, even if the charging current has fallen below **[Bulk to Float Transition Current]**, until the system has been in the Bulk charging state for **[Bulk Delay Time Hours] + [Bulk Delay Time Minutes]**.

[Battery Temperature]	Parameter #	1015
	Type	Write-USER CWR AIn AOut
	Range	[-273 . . 320]
	Units	Degrees C
	Default	0

The battery temperature must be fed into this parameter in order to control the temperature compensation function. This can be done through an analog input channel, through MODBUS serial communication, or manually through the web-based user-interface or front panel interface.



WARNING: Programming temperature compensation parameters that are not suitable for the type of battery being used may damage the battery and the inverter and may cause a hazardous condition that puts personnel at risk of grave injury or death. The user must ensure that the battery temperature compensation parameters are appropriate and safe for the type and voltage rating of the battery used.

[Battery Temp Analog Lo]	Parameter #	1016
	Type	Write-USER
	Range	[-273 . . 320]
	Default	0
[Battery Temp Analog Hi]	Parameter #	1017
	Type	Write-USER
	Range	[-273 . . 320]
	Default	100

These parameters are the analog mapping parameters for **[Battery Temperature]**.

[Temperature Compensation Enable]	Parameter #	1018
	Type	Write-USER CWR
	Range	[0,1]
	Default	0

Setting this parameter to “1” enables the temperature compensation function.

[Temperature Compensation Per]	Parameter #	1019
---------------------------------------	-------------	------

[Cell]	Type	Write-USER
	Range	[0,1]
	Default	0.003
[Number of Cells]	Parameter #	1020
	Type	Write-USER
	Range	[0 . . 32000]
	Default	20

[Temperature Compensation Per Cell] times **[Number of Cells]** is the voltage that is added to **[Bulk Charging Voltage]** and **[Float Charging Voltage]**, per degree Celsius by which **[Battery Temperature]** differs from 25C.

[Bulk Time Out]	Parameter #	1022
	Type	Write-USER
	Range	[0 . . 320]
	Units	Hours
	Default	24

If the inverter has been charging the battery in Bulk mode for the number of hours programmed into **[Bulk Time Out]**, the inverter will turn off. This will occur if the Bulk Delay Time has passed, and the charging current is still above **[Bulk to Float Transition Current]** when **[Bulk Time Out]** is reached. This may indicate a problem with the batteries and is available for safety reasons.

[Battery Minimum Voltage Limit]	Parameter #	1024
	Type	Write-USER CWR
	Range	[0 . . 1000]
	Units	V
	Default	0

Minimum battery voltage maintained by the inverter during discharging. If battery voltage falls below this value, the inverter will decrease the power output from the battery to maintain this limit.

[Battery Charging Voltage Limit]	Parameter #	1026
	Type	Read Only
	Range	[0 . . 1000]
	Units	V
	Default	0

Current charging voltage limit that the inverter is trying to maintain. It should be Bulk Charging Voltage, Float Charging Voltage or Equalization Voltage plus the voltage calculated by temperature compensation function.

[Generator On Command]	Parameter #	1027
	Type	Read Only DOut
	Range	[0,1]
	Units	
	Default	0

[Generator On Voltage]	Parameter #	1028
	Type	<input type="button" value="Write-USER"/> <input type="button" value="CWR"/>
	Range	[0 . . 600]
	Units	V
	Default	0
[Generator Off Voltage]	Parameter #	1029
	Type	<input type="button" value="Write-USER"/> <input type="button" value="CWR"/>
	Range	[0 . . 600]
	Units	V
	Default	0

The inverter can start and stop a generator based on the battery voltage when the inverter is connected to a generator instead of the grid. When the battery voltage goes below the **[Generator On Voltage]**, **[Generator On Command]** will be set to 1. When the battery voltage goes above the **[Generator Off Voltage]**, **[Generator On Command]** will be set to 0. **[Generator On Command]** can be mapped to a digital output which can be used to start and stop a generator.

[Maximum Discharging Current]	Parameter #	1030
	Type	<input type="button" value="Write-USER"/> <input type="button" value="CWR"/>
	Range	[-10 . . 650]
	Units	Amps
	Default	645

Current is limited to this value when discharging the battery.

Grid Control Setting Parameters

[\[AI Sag Frequency\]](#)

[\[On-grid Surge Voltage\]](#)

[\[AI Frequency Sag Time\]](#)

[\[On-grid Power Limit\]](#)

[\[AI Sag Voltage\]](#)

[\[On-grid Power Limit Analog Lo\]](#)

[\[AI Surge Voltage\]](#)

[\[On-grid Power Limit Analog Hi\]](#)

[\[On-grid Sag Voltage\]](#)

[AI Sag Frequency]	Parameter #	1104
	Type	<input type="button" value="Write-USER"/>
	Range	[-3 . . -0.2]
	Units	Hz
	Default	-0.7
[AI Frequency Sag Time]	Parameter #	1105
	Type	<input type="button" value="Write-USER"/>
	Range	[0.16 . . 300]
	Units	Seconds
[AI Sag Voltage]	Parameter #	1109
	Type	<input type="button" value="Write-USER"/>
	Range	[50 . . 88]

	Units	%
	Default	88
[AI Surge Voltage]	Parameter #	1110
	Type	Write-USER
	Range	[110. . . 120]
	Units	%
	Default	110.0

These parameters are adjustable by the user so that the inverter can be adjusted to meet local utility interconnection regulations while avoiding nuisance tripping due to normal local grid variations. If any of the following conditions occur, the inverter will likewise cease exporting power to the grid in order to comply with UL-1741 regulations:

If the grid voltage frequency drops below **[AI Sag Frequency]+Nominal Frequency** for longer than **[AI Frequency Sag Time]**,

or,

If the grid voltage frequency goes above $0.5\text{Hz} + \text{Nominal Frequency}$ for 0.16 seconds

or,

If the grid RMS voltage goes outside of the limits defined by **[AI Sag Voltage]*Nominal Voltage** and **[AI Surge Voltage]*Nominal Voltage**,

the inverter will cease exporting power to the grid in order to comply with UL-1741 regulations.

Nominal Frequency and **Nominal Voltage** are set by the factory. The default values are 60Hz and 480V respectively.

Once the grid voltage and frequency have returned within these limits continuously for 5 minutes, then the inverter will resume exporting power to the grid.

[On-grid Sag Voltage]	Parameter #	1124
	Type	Write-USER
	Range	[0. . . 320]
	Units	%
	Default	66.67
[On-grid Surge Voltage]	Parameter #	1125
	Type	Write-USER
	Range	[0. . . 320]
	Units	%
	Default	116.67

These parameters are equivalent to **[AI Sag Voltage]** and **[AI Surge Voltage]** when the inverter is configured to run in the micro-grid mode (factory set). If the grid RMS voltage goes outside of the limits defined by **[On-grid Sag Voltage]*Nominal Voltage** and **[On-grid Surge Voltage]*Nominal Voltage**, or of the grid voltage frequency goes outside of the range between 53Hz and 65Hz, the inverter will cease exporting power to the micro-grid.

Once the grid voltage and frequency have returned within these limits continuously for 2 seconds, then the inverter will resume exporting power to the micro-grid.

Reserved Section

Reserved Section

Control Function Owners Parameters

The Control Function Owners feature allows users, for security or process control reasons, to disable write-access to critical parameters from particular interfaces. The default configuration for most parameters is to be writeable from any one of the four interfaces, which means that the parameter has four “owners”. However, functionality-critical parameters, such as run/stop/enable control, speed control, and torque and current limits have owner settings that can be changed.

[X Owner]	Parameter #	1401 – 1405
	Type	<input type="checkbox"/> Write-USER <input type="checkbox"/> BIN <input type="checkbox"/> CWR
	Range	xxx1 Digital/Analog Interface Ownership xx1x Modbus Interface Ownership x1xx Front Panel Interface Ownership 1xxx Web Interface Ownership
	Default	1111 (binary)

1401 - [Inverter On Owner]

1402 - [Inverter Reset Owner]

1403 - [External Trip Owner]

1404 - [Power Command Owner]

System parameters with write-access can be changed from four different interfaces:

Analog/Digital Inputs

Modbus Interface

Front Panel Interface

Web Interface

To prevent a certain interface from changing a parameter, change the interface’s ownership bit to zero in that parameter’s ownership parameter:

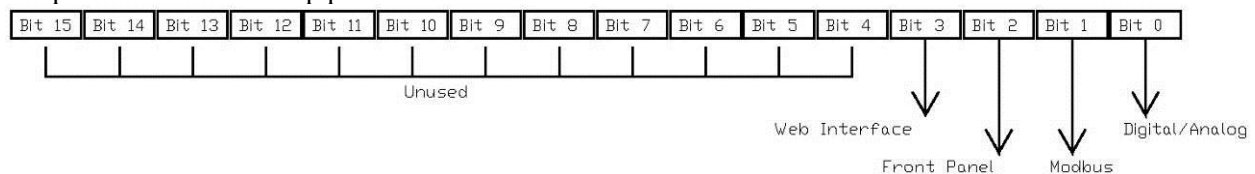

For example, to configure the inverter such that the system cannot be run via the Modbus interface, set the **[Inverter On Owner]** parameter to 1101 (binary). By setting the second bit to zero, the Modbus interface is no longer an owner of the **[Inverter On Owner]** parameter and cannot change that value.

Inverter Status Registers

[\[Inverter Status 1\]](#)

[\[Inverter Status 2\]](#)

[\[System State\]](#)

The inverter status registers are binary parameters that contain information about the system state at any given time. Each bit of each status register expresses one piece of information, like whether or not main DC contactor is closed or whether the Battery is charging or discharging. Sometimes multiple bits are grouped together to form a number that can express more complex information, as is the case with bits 0 and 1 of **[Inverter Status 1]**, which represent the four possible system states. Reference the diagrams below to find which information is expressed by each bit in the status registers.

[Inverter Status 1]	Parameter #	1501
	Type	Read Only BIN
	Range	[0000000000000000 . . . 1111111111111111]
	Default	0

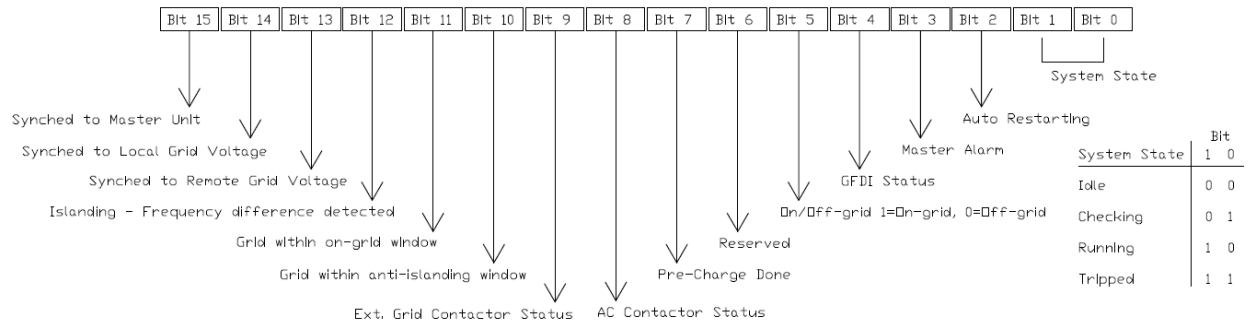

[Inverter Status 2]	Parameter #	1502
	Type	Read Only BIN
	Range	[0000000000000000 . . . 1111111111111111]
	Default	0

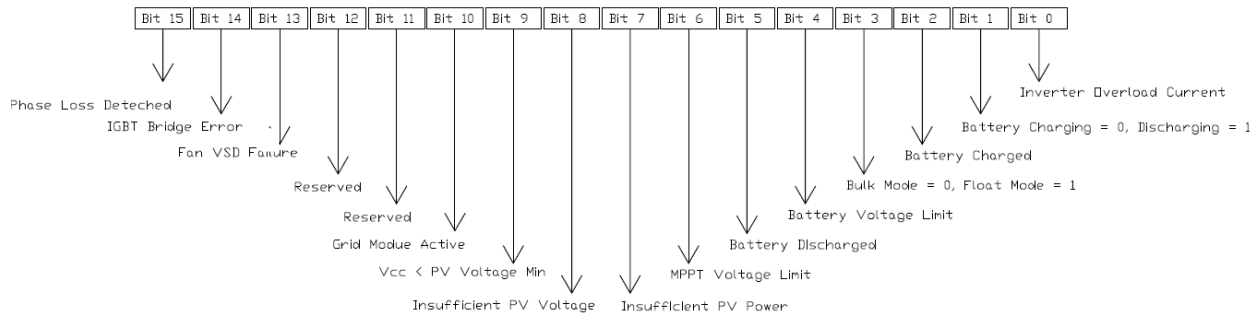

[System State]	Parameter #	1503
	Type	Read Only
	Range	16 = Idle 34 = Checking 51 = Running 64 = Tripped
	Default	0

Digital Input Parameters

[\[DI0 Parameter ID\]](#), [\[DI1 Parameter ID\]](#)

[\[Digital Input Invert Mask\]](#)

[\[Digital Input Status\]](#)

The inverter is equipped with 2 digital inputs for sending “high/low” signals to the inverter, all of which can be mapped to a number of “digital” parameters within the system. Each digital input has a parameter associated with it (**[DIx Parameter ID]**) that contains the ID number for the parameter to which it is mapped.

For digital inputs, 24VDC signals are used to indicate “high” or “low”. When a digital input is mapped to a parameter, then the parameter is set to 1 every time the input goes “high”, and is set to 0 every time the input goes “low”. Whether 24V means “high” and 0V means “low” or vice-versa is configurable for each channel.

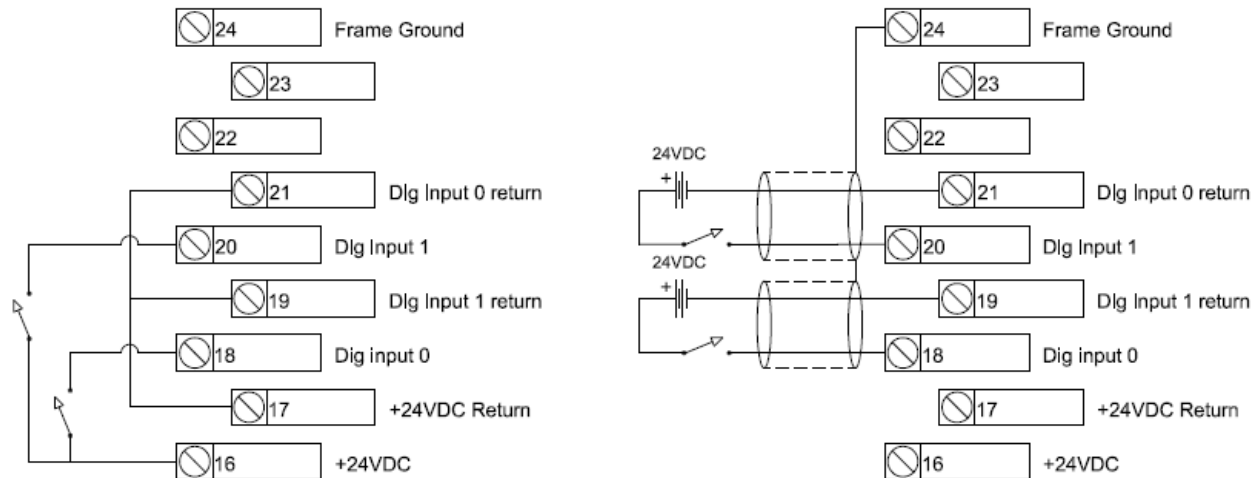

Figure 3-15 – Digital input configuration – Terminals on header J27

24VDC is supplied on the user I/O terminal strip for use in setting up digital input signals. This power supply can be used to convert a relay (contact-closure) input to a 0-24VDC signal, allowing the user to provide input signals to the inverter using relays or other contact-closure systems. The figure at left illustrates how to connect a digital input relay/switch using the on-board 24V power supply. Since the users supply is isolated, a connection must be made between the corresponding digital input return and the power supply return, as shown. The figure at the right shows a configuration with user supplied 24VDC sources. A cable shield drain is also shown.

[DI0 Parameter ID] [DI1 Parameter ID]	Parameter #	1601, 1602
	Type	Write-USER
	Range	[0 . . . Maximum Parameter ID]
	Units	1
	Default	0

These parameters contain the ID numbers for the parameters to which the 2 digital inputs are mapped. The parameters that can be mapped to digital inputs are in the following table. To map a digital input to one of these parameters, enter the parameter ID for that parameter into the **[DIx Parameter ID]** parameter associated with the desired digital input.

Parameter Name	ID
[Inverter On]	701
[Inverter Reset]	702
[Battery Port Enable]	703
[PV Port Enable]	704
[Grid Port Enable]	705
[External Trip]	2202

Figure 3-16: Digital Input Parameter ID's

[Digital Input Invert Mask]	Parameter #	1603
	Type	<input type="checkbox"/> Write-USER <input type="checkbox"/> BIN
	Range	[0000000000000000 . . . 0000000000000011] bit=0 - Don't invert the detected digital input value bit=1 - Invert the detected digital input value
	Default	0

This parameter controls whether or not each digital input signal is inverted before being mapped to its corresponding parameter. Bits 0 and 1 correspond to digital inputs 1 and 2 respectively, as shown in the diagram under **[Digital Input Status]**. If the invert bit for a given input is 0, then 24V on the input will translate to a “1” in the mapped parameter, and 0V will translate to a “0”. If the invert bit is 1, then 24V on the input will translate to a “0”, and 0V to “1”.

[Digital Input Status]	Parameter #	1604
	Type	<input type="checkbox"/> Read Only <input type="checkbox"/> BIN
	Range	[0000000000000000 . . . 0000000000000011] bit=0 - Digital input is inactive bit=1 - Digital input is active
	Default	0

This parameter contains the status of the 2 digital inputs. The first 2 bits represent the status of one of the inputs. Note that this takes the values of **[Digital Input Invert Mask]** into account. **[Digital Input Status]** represents what values would be sent to parameters mapped to the digital inputs.

Digital Output Parameters

- [\[DO0 Parameter ID\]](#), [\[DO1 Parameter ID\]](#)
- [\[Digital Output Invert Mask\]](#)
- [\[Digital Output Status\]](#)

The inverter is equipped with 2 digital outputs for sending “high/low” signals from the inverter, all of which can be mapped to a number of “digital” parameters within the system. Each digital output has a parameter associated with it (**[DOx Parameter ID]**) that contains the ID number for the parameter to which it is mapped.

The digital outputs consist of a set of 2 relays that are controlled by the “high/low” status of the digital output signals. As with the digital inputs, the polarity of each digital output relative to its mapped parameter can be configured individually. Each relay also has a “Normally Open” (NO) and a “Normally Closed” (NC)

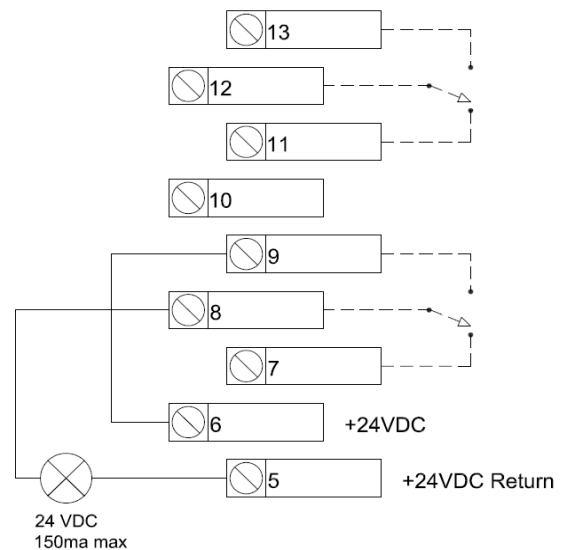

set of contacts, for further flexibility. When the mapped value is logic (0), the NO terminal will be open and the NC terminal will be closed. When the mapped value is logic (1), the NO terminal will be closed and the NO terminal will be open.

24VDC is supplied on the user I/O terminal strip for use in setting up digital output signals. As shown in the figure above, this power supply can be used to turn the relay outputs into 0-24VDC digital voltage signals to power lighted indicators or the inputs of a facility control system. An external power supply could also be used if a different voltage or current limit is required.



Caution: Do not attach a load to the digital outputs that will exceed the 150 mA current rating. Doing so could result in component damage on the I/O board.

[DO0 Parameter ID] [DO1 Parameter ID]	Parameter #	1701, 1702
	Type	<input type="text" value="Write-USER"/>
	Range	[0 . . . Maximum Parameter ID]
	Units	1
	Default	0

These parameters contain the ID numbers for the parameters to which the 2 digital outputs are mapped. The parameters that can be mapped to digital outputs are in the following table. To map a digital output to one of these parameters, enter the parameter ID for that parameter into the **[DOx Parameter ID]** parameter associated with the desired digital output.

<u>Parameter Name</u>	<u>ID</u>
[Inverter On]	701
[Battery Port Enable]	703
[PV Port Enable]	704
[Grid Port Enable]	705
[Generator On Command]	1027
[Master Alarm]	2001
[User Alarm]	2010
[System Tripped]	2201
[External Trip]	2202

Figure 3-17: Digital Output Parameter ID's

[Digital Output Invert Mask]	Parameter #	1703
	Type	<input type="text" value="Write-USER"/> <input type="text" value="BIN"/>
	Range	[0000000000000000 . . . 0000000000000011] bit=0 - Digital output equals the mapped parameter bit=1 - Digital output is inverted
	Default	0

This parameter controls whether or not each digital output signal is inverted relative to the parameter to which it is mapped. Bits 0 and 1 correspond to digital outputs 1 and 2 respectively, as shown in the diagram under **[Digital Output Status]**. If the invert bit for a given output is 0, then when the mapped parameter is equal to 1, the relay will activate, and it will deactivate when the mapped parameter equals 0. If the bit is 1, this will be reversed, and the relay will activate when the mapped parameter equals 0. Note that all relays will deactivate when the system power is off.

[Digital Output Status]	Parameter #	1704
	Type	<input type="button" value="Read Only"/> <input type="button" value="BIN"/>
	Range	[0000000000000000 . . . 0000000000000011] bit=0 - Digital output is inactive bit=1 - Digital output is active
	Default	0

This parameter contains the status of the 2 digital outputs. The first 2 bits represent the status of one of the inputs. Note that this takes the values of **[Digital Output Invert Mask]** into account. The relay for a given output will be active when the bit for that output in this register is 1.

Analog Input Parameters

[\[AI0 Parameter ID\] . . . \[AI2 Parameter ID\]](#)

[\[AI0 Signal Lo\] . . . \[AI2 Signal Lo\]](#)

[\[AI0 Signal Hi\] . . . \[AI2 Signal Hi\]](#)

[\[AI0 Signal Val\] . . . \[AI2 Signal Val\]](#)

The system has 3 analog inputs that can be used to send analog signals to the inverter. Each of the 3 signals can be configured either as a 0-10V voltage input, or a 0-20mA current input. Each of the inputs can be mapped to a number of parameters in the system, and the range and scaling configuration for that mapping is configurable for each input individually.

The analog input signals are connected to J36 on the BIGI interface I/O board as shown. The selection of 0-10V input or 0-20mA input is done using the set of 3 analog input selection switches, also on the BIGI interface I/O board as shown by the yellow arrows. A switch in the “A” position configures the input as a 0-20mA channel. A switch in the “V” position configures the input as a 0-10V channel.

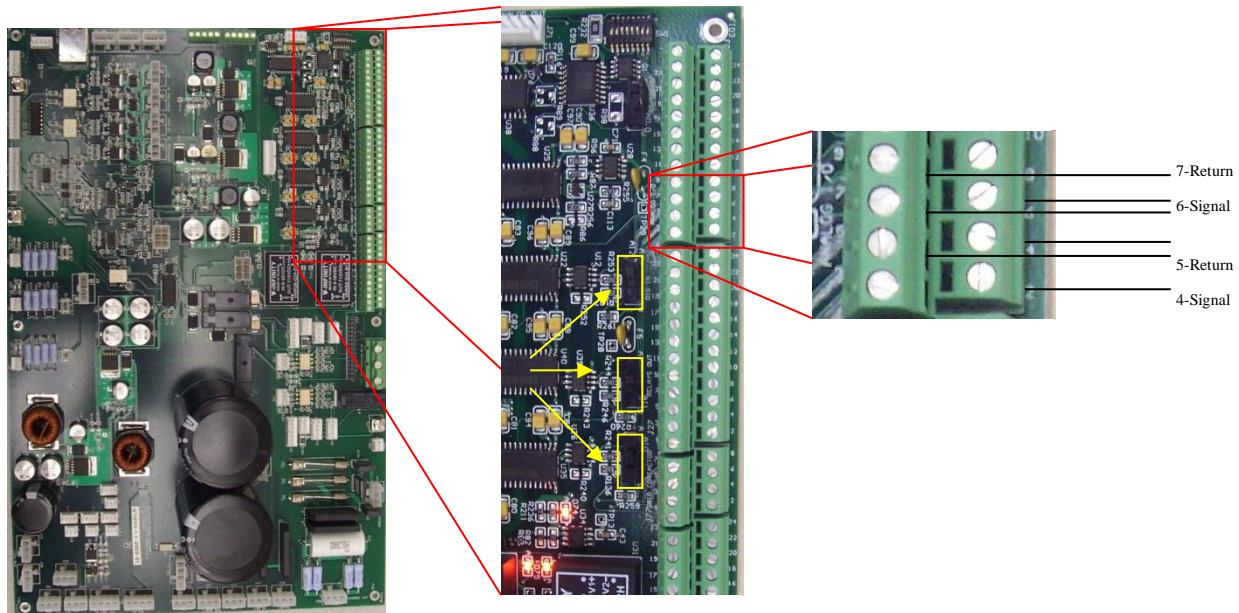

Figure 3-18: Interface I/O Card – Analog Inputs



Caution: Configuring an analog input for 0-20mA operation and driving it instead with a voltage source could cause component damage on the I/O board.

The use of shielded twisted pair wiring is recommended for all analog control signals. Shields should be connected to the FRAME terminal, terminal 1 on J36.

The analog inputs can be driven from a potentiometer (such as a front panel rotary knob) powered by the I/O board itself. A 10V voltage supply is available on terminal 8 of J36, its return is on terminal 9, for facilitating such a circuit.

The analog input can also be driven from an external signal source. In this case, the signal wire is connected to the “signal” terminal and the return wire is connected to the “return” terminal.

Each system parameter that can be mapped to an analog input has two parameters associated with it called **[xxx Analog Hi]**, and **[xxx Analog Lo]**. These parameters are in the same units as their parent parameter (the parameter to be mapped). These define the range that the mapped parameter will traverse when it is mapped to an analog input.

Each analog input channel has two parameters associated with it as well, **[AIx Signal Hi]** and **[AIx Signal Lo]**, that define the part of the range of the input signal that will correspond to the mapped parameter’s range defined by **[xxx Analog Hi]** and **[xxx Analog Lo]**. If an input signal goes above or below this range, the parameter will be set to its **[xxx Analog Hi]** or **[xxx Analog Lo]** value respectively. See below diagram.

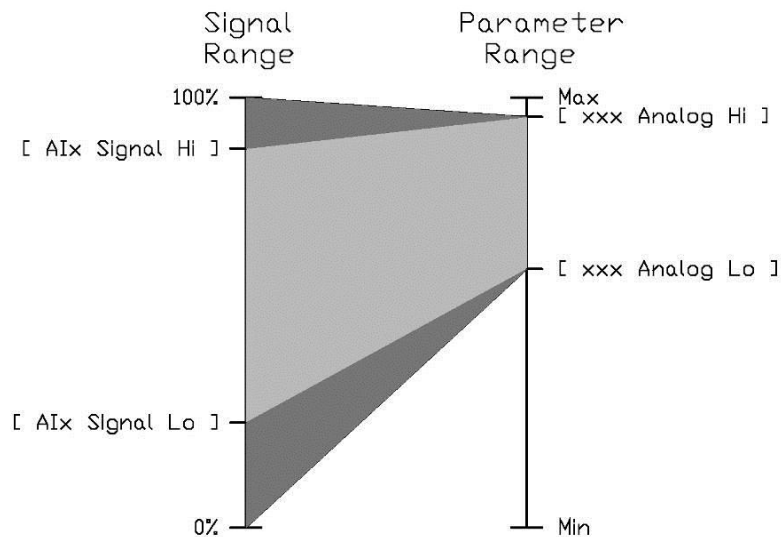

Figure 3-19 Analog Input Signal Range

[AI0 Parameter ID]	Parameter #	1801, 1806, 1811
[AI1 Parameter ID]	Type	Write-USER
[AI2 Parameter ID]	Range	[0 . . . Maximum Parameter ID]
	Units	1
	Default	0

These parameters contain the ID numbers for the parameters to which the 3 analog inputs are mapped. The parameters that can be mapped to analog inputs are in the following table. To map an analog input to one of these parameters, enter the parameter ID for that parameter into the [AIx Parameter ID] parameter associated with the desired digital output.

Parameter Name	ID
[Power Command]	706
[Reactive Power Command]	707
[Battery Temperature]	1015

Figure 3-20: Analog Input Parameter ID's

[AI0 Signal Lo]	Parameter #	1802, 1807, 1812
[AI1 Signal Lo]	Type	Write-USER
[AI2 Signal Lo]	Range	[0 . . . 100] %
	Units	.01 %
	Default	0

[AI0 Signal Hi] [AI1 Signal Hi] [AI2 Signal Hi]	Parameter #	1803, 1808, 1813
	Type	Write-USER
	Range	[0 . . . 100] %
	Units	.01 %
	Default	100 %

These parameters define the range of the signal that is to be used. This range will correspond to the range for the mapped parameter defined by that parameter’s Analog Lo and Analog Hi parameters (see above diagram). Note: signal loss detection, if used, is triggered by a signal that falls below [AIx Signal Lo] – 5%. (See “Loss of Signal Fault”).

[AI0 Signal Val] [AI1 Signal Val] [AI2 Signal Val]	Parameter #	1804, 1809, 1814
	Type	Read Only
	Range	[0 . . . 100] %
	Units	.01 %
	Default	0

These parameters contain the present raw value of the analog input signal. This value is un-processed, and is expressed as a % of the full range of the analog input, which is either 0-10V or 0-20mA.

Analog Output Parameters

- [\[AO0 Parameter ID\]](#)
- [\[AO0 Signal Lo\]](#)
- [\[AO0 Signal Hi\]](#)
- [\[AO0 Signal Val\]](#)

The system has 1 analog output that can be used to send analog signals from the inverter. The analog output can be configured either as a 0-10V voltage output, or a 0-20mA current output. The analog output can be mapped to a number of parameters in the system, and the range and scaling configuration for that mapping is configurable for each output individually.

The analog output signal is connected to J36 on the BIGI interface I/O board as shown. The selection of 0-10V input or 0-20mA output is done using the analog output selection switch, also on the BIGI interface I/O board. The switch in the “A” position configures the output as a 0-20mA channel. The switch in the “V” position configures the output as a 0-10V channel.

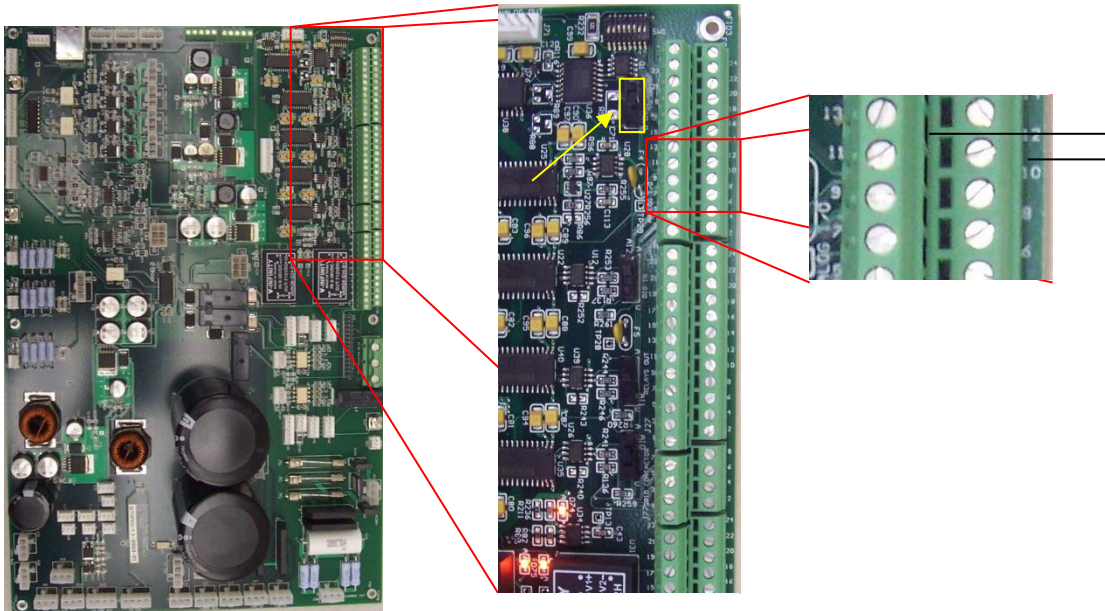

Figure 3-21 Interface I/O Board - Digital Outputs



Caution: Configuring an analog output to source 0-10V and connecting it to an external current sensor could cause component damage to the external sensor.

Each system parameter that can be mapped to an analog output has two parameters associated with it called **[xxx Analog Hi]**, and **[xxx Analog Lo]**. These parameters are in the same units as their parent parameter (the parameter to be mapped). These define the range of the mapped parameter that will be mapped to the analog output.

The analog output channel has two parameters associated with it as well, **[AO0 Signal Hi]** and **[AO0 Signal Lo]**, that define the part of the range of the output signal that will correspond to the mapped parameter's range defined by **[xxx Analog Hi]** and **[xxx Analog Lo]**. If a mapped parameter goes above or below the range defined by **[xxx Analog Hi]** and **[xxx Analog Lo]** then the analog output will be set to its **[AO0 Signal Hi]** or **[AO0 Signal Lo]** value respectively. See diagram below.

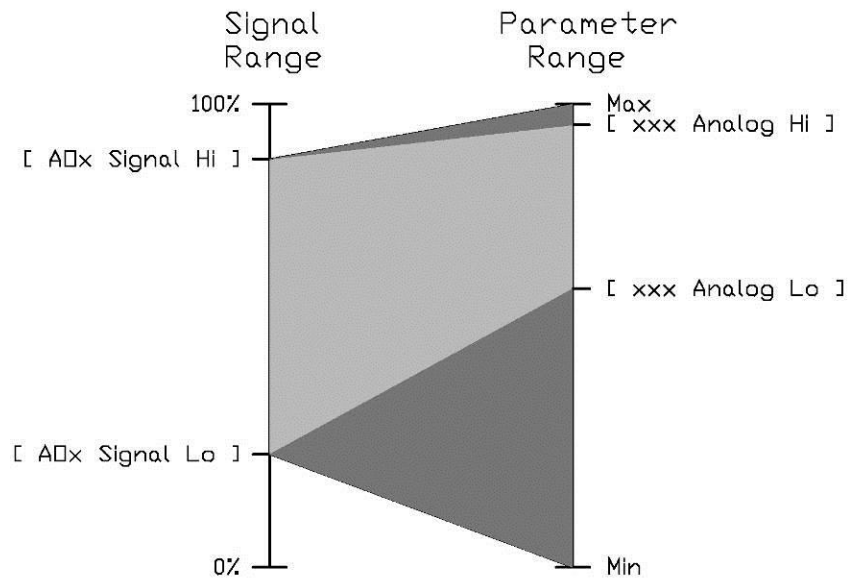

Figure 3-22: Analog Output Signal Range

[AO0 Parameter ID]	Parameter #	1901
	Type	Write-USER
	Range	[0 . . . Maximum Parameter ID]
	Units	1
	Default	0

This parameter contains the ID numbers for the parameters to which the analog output is mapped. The parameters that can be mapped to analog outputs are in the following table. To map a parameter to the analog outputs, enter the parameter ID for that parameter into the **[AO0 Parameter ID]** parameter associated with the desired digital output.

<u>Parameter Name</u>	<u>ID</u>	<u>Parameter Name</u>	<u>ID</u>
[Power Command]	706	[Battery Current]	822
[Reactive Power Command]	707	[Battery Power]	825
[Grid AC Voltage AB]	801	[PV Voltage]	829
[Grid AC Voltage BC]	802	[PV Current]	832
[Grid AC Voltage CA]	803	[PV Power]	835
[Inverter AC Voltage]	806	[Battery Temperature]	1015
[Inverter AC Current]	809	[Bat Port Heatsink Temperature]	2213
[Inverter AC Power Real]	812	[Grid Port Heatsink Temperature]	2218
[Inverter AC Power Reactive]	813	[Ambient Temperature]	2223
[AC Bridge Current]	816	[PV Port Heatsink Temperature]	2228

[Battery Voltage]	819	Temperature]
-------------------	-----	--------------

Figure 3-23: Analog Output Parameter ID's

All of the above parameters have an associated pair of Analog hi/lo parameters for analog mapping. **[Bat Port Heatsink Temperature]**, **[Grid Port Heatsink Temperature]**, **[PV Port Heatsink Temperature]** and **[Ambient Temperature]** all share a common pair, **[Temperature Analog Hi]** and **[Temperature Analog Lo]**.

[AO0 Signal Lo]	Parameter #	1902
	Type	Write-USER
	Range	[0 . . . 100] %
	Units	.01 %
	Default	0

[AO0 Signal Hi]	Parameter #	1903
	Type	Write-USER
	Range	[0 . . . 100] %
	Units	.01 %
	Default	100 %

These parameters define the range of the output signal that is to be used. This range will correspond to the range for the mapped parameter defined by that parameter's Analog Lo and Analog Hi parameters (see above diagram).

[AO0 Signal Val]	Parameter #	1904
	Type	Read-Only
	Range	[0 . . . 100] %
	Units	.01 %
	Default	0

These parameters contain the present raw value of the analog output signal. This value is expressed as a % of the full range of the analog input, which is either 0-10V or 0-20mA.

Alarm Parameters

[\[Master Alarm\]](#)

[\[Alarm Status\]](#)

[\[Master Alarm Mask\]](#)

[\[Battery Under Voltage Alarm Threshold\]](#)

[\[Battery Under Temperature Alarm Threshold\]](#)

[\[Temperature Alarm Threshold\]](#)

[\[User Alarm Parameter ID\]](#)

[\[User Alarm Threshold\]](#)

[\[User Alarm Greater/Less\]](#)

[\[User Alarm\]](#)

Master Alarm Parameters

[Master Alarm]	Parameter #	2001
	Type	<input type="checkbox"/> Read Only <input type="checkbox"/> DOut
	Range	0 No alarms active 1 At least 1 alarm active
	Default	0

[Master Alarm] is set equal to 1 whenever any alarm selected in **[Master Alarm Mask]** is active. This parameter is mappable to a digital output so that it may be monitored by a remote system.

[Master Alarm Mask]	Parameter #	2003
	Type	<input type="checkbox"/> Read Only <input type="checkbox"/> BIN
	Range	[0000000000000000 . . . 00000000011111111] bit=0 - Alarm will not activate the [Master Alarm] bit=1 - Alarm will activate the [Master Alarm]
	Default	0

The parameter **[Master Alarm Mask]** determines which alarms are linked to the **[Master Alarm]**. Each bit of the parameter corresponds to one of the alarms, as shown in the below diagram. To link an alarm to the **[Master Alarm]** parameter, set the corresponding bit in **[Master Alarm Mask]** to 1. If an alarm's bit is set to zero, then the master alarm will not be set to 1 when that alarm is active.

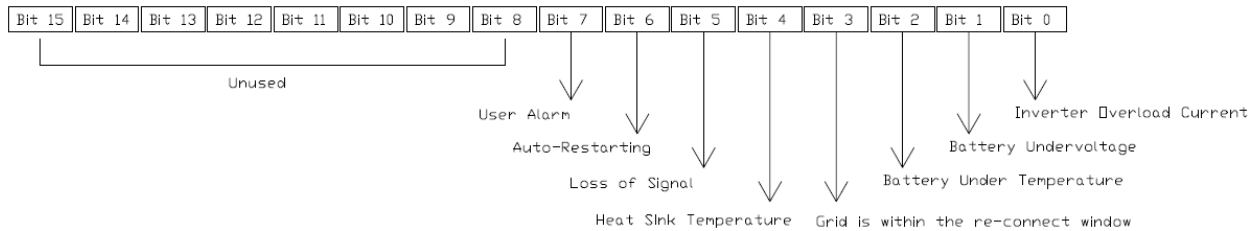

Alarm Status Parameters

[Alarm Status]	Parameter #	2002
	Type	<input type="checkbox"/> Read Only <input type="checkbox"/> BIN
	Range	[0000000000000000 . . . 00000000011111111] bit=0 - Alarm is inactive bit=1 - Alarm is active
	Default	0

The parameter **[Alarm Status]** indicates which alarms are active. Each bit of the parameter corresponds to one of the alarms, as shown in the below diagram. For any alarm that is active, its corresponding bit within this parameter will be equal to 1.

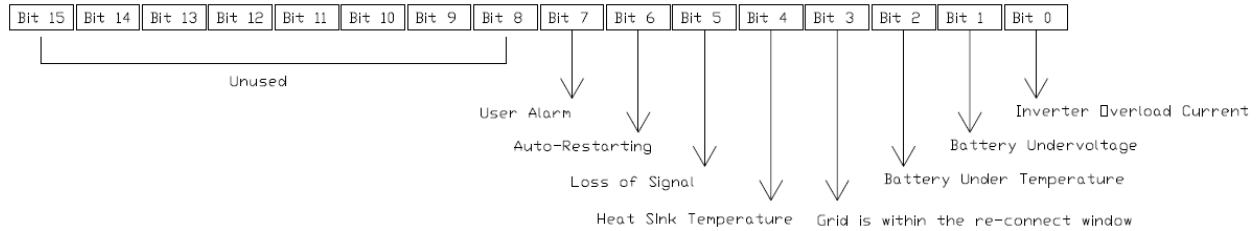

Inverter Overload Current Alarm

This alarm is active when the inverter AC bridge current is above the Inverter Overload Threshold current, which is defined as 340A.

Battery Under Voltage Alarm

This alarm is active when the battery voltage is below the **[Battery Under Voltage Alarm Threshold]** parameter.

[Battery Under Voltage Alarm Threshold]	Parameter #	2004
	Type	<input checked="" type="checkbox"/> Write-USER <input type="checkbox"/> CWR
	Range	[0 . . . 3200] Volts
	Units	.1 Volts
	Default	500 Volts

Battery Under Temperature Alarm

This alarm is active when the battery voltage is below the **[Battery Under Temperature Alarm Threshold]** parameter.

[Battery Under Temperature Alarm Threshold]	Parameter #	2005
	Type	<input checked="" type="checkbox"/> Write-USER <input type="checkbox"/> CWR
	Range	[-273 . . . 175] C
	Units	.01 C
	Default	-5 C

Grid is Within the Reconnect Window Alarm

This alarm is active when the inverter detects that the abnormal conditions are cleared and the grid voltage and frequency are back within the reconnect window defined by IEEE1547.

Heat Sink Temperature Alarm

Heat sink temperature reached threshold. The alarm threshold should be lower than the trip threshold.

[Temperature Alarm Threshold]	Parameter #	2006
	Type	<input checked="" type="checkbox"/> Write-USER <input type="checkbox"/> CWR
	Range	[-320 . . . 320] C
	Units	.01 C

	Default	100 C
--	---------	-------

Loss of Signal Alarm

Signal on any analog inputs goes below trip threshold Alarm is enabled even if the trip is disabled.

Auto-Restarting Alarm

If Auto restart is allowable for a fault that occurs, this alarm will activate as soon as the fault occurs, and will remain active until the inverter restarts.

User Configurable Alarm

This alarm is a user-configurable alarm. This alarm is activated when any system parameter of the user's choice goes above or below a user-settable threshold.

[User Alarm Parameter ID]	Parameter #	2007
	Type	<input type="checkbox"/> Write-USER <input type="checkbox"/> CWR
	Range	[0 . . . Maximum Parameter ID]
	Units	1
	Default	0

The user enters the ID for the User Alarm parameter in this parameter. Any parameter ID may be used.

[User Alarm Threshold]	Parameter #	2008
	Type	<input type="checkbox"/> Write-USER <input type="checkbox"/> CWR
	Range	[0 . . . 100] %
	Units	.01 %
	Default	70 %

The user defines the User Alarm threshold with this parameter. The threshold is defined as a % of the full range of the User Alarm parameter (defined by **[User Alarm Parameter ID]**). For instance, if the range for the selected parameter is [-50 . . . 150], then to set a threshold of 100, the user would enter 75% in **[Load Loss Alarm Threshold]**, because 100 is 75% of the way from -50 to 150.

[User Alarm Greater/Less]	Parameter #	2009
	Type	<input type="checkbox"/> Write-USER <input type="checkbox"/> CWR
	Range	0 Less than 1 Greater than
	Default	1

This parameter determines whether the alarm is activated when the parameter value goes above the user's threshold or when it goes below the threshold. If **[User Alarm Greater/Less]** is set to 1, the alarm will activate when the value of the selected parameter goes above the threshold defined by **[User Alarm Threshold]**. If **[User Alarm Greater/Less]** is set to 0, the alarm will activate when the value of the selected parameter goes below the threshold.

[User Alarm]	Parameter #	2010
---------------------	-------------	------

	Type	<input type="button" value="Read Only"/> <input type="button" value="DOut"/>
	Range	0 User Alarm not active 1 User Alarm Active
	Default	0

This parameter is set to 1 when the User Alarm is active, and is set to 0 when the User Alarm is not active. This parameter is mappable to a digital output so that it may be monitored by a remote system.

Auto Restart

[\[Auto Restart Attempts\]](#)

[\[Auto Restart Delay\]](#)

[\[Auto Restart Counter\]](#)

[\[Auto Restart Enable Mask 0\]](#)

[Auto Restart Attempts]	Parameter #	2101
	Type	<input type="button" value="Write-USER"/> <input type="button" value="CWR"/>
	Range	[0 . . . 20]
	Default	1

This parameter defines the number of times the inverter will automatically reset and restart itself after a trip occurs. Setting this parameter to 0 disables the Auto-restart function. Auto-restarts will only occur after trips for which Auto-restart is authorized. (See Faults Section) Upon restart, the inverter will issue itself a standard run signal, and operate accordingly.

[Auto Restart Delay]	Parameter #	2102
	Type	<input type="button" value="Write-USER"/> <input type="button" value="CWR"/>
	Range	[5 . . . 300] seconds
	Units	.01 seconds
	Default	10

This parameter defines the amount of time the inverter will wait before restarting itself after a trip for which Auto-restart is authorized.

[Auto Restart Counter]	Parameter #	2103
	Type	<input type="button" value="Read Only"/>
	Range	[0 . . . 20]
	Default	0

This parameter is incremented by 1 every time the inverter auto-restarts itself. If **[Auto Restart Counter]** reaches the value stored in **[Auto Restart Attempts]**, then any further trips will not be followed by a restart. **[Auto Restart Counter]** will be reset to zero whenever the inverter is stopped by the user. The counter will also be set to zero automatically if the inverter runs for 5 minutes without tripping.

[Auto Restart Enable Mask 0]	Parameter #	2104
-------------------------------------	-------------	------

	Type	Write-USER BIN CWR
	Range	[0000000000000000 . . . 0000000001111111] bit=0 - Auto-restart disabled for the fault bit=1 - Auto-restart enabled for the fault
	Default	0000000000000000

This parameter determines on which faults the inverter will perform an auto-restart. This parameter is a 16-bit binary number, each bit of which corresponds to a fault. If the Auto-Restart Enable bit for a given fault is 1, then the inverter will perform an auto-restart when this fault occurs. If the bit is 0, the inverter will remain stopped after the fault.

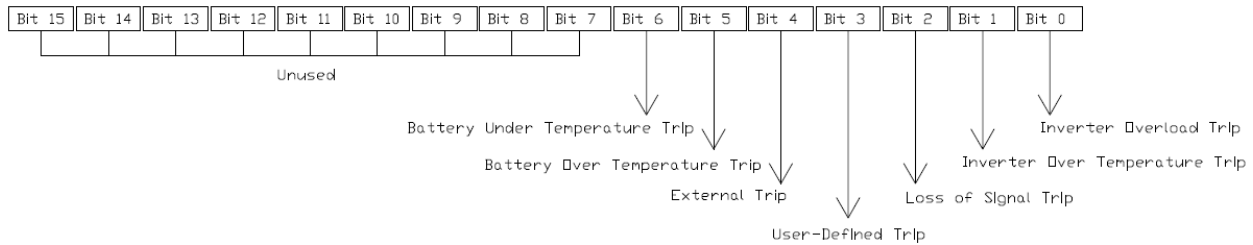

System Faults

- [\[System Tripped\]](#)
- [\[Signal Loss Enable\]](#)
- [\[User Trip Parameter ID\]](#)
- [\[User Trip Threshold\]](#)
- [\[User Trip Greater/Less\]](#)
- [\[User Trip Enable\]](#)
- [\[External Trip\]](#)
- [\[Temperature Analog Lo\]](#)
- [\[Temperature Analog Hi\]](#)



- [\[Battery Heatsink Temperature\]](#)
- [\[PV Heatsink Temperature\]](#)
- [\[Grid Heatsink Temperature\]](#)
- [\[Ambient Temperature\]](#)
- [\[Fan VSD Run Command\]](#)
- [\[Communication Watchdog Enable\]](#)
- [\[Communication Watchdog\]](#)
- [\[Communication Watchdog Timeout\]](#)

This section outlines the various system faults and their associated parameters. If a fault is issued for any reason, the inverter will stop. After the inverter stops, it will enter the “Tripped” state until the fault is cleared. Some faults are self-clearing, and will clear automatically as soon as the corresponding fault conditions are alleviated. For all other faults, after the fault conditions no longer exist, the fault must be cleared by resetting the inverter. The inverter may be reset by issuing a Reset command, or by toggling the **[Inverter On]** signal. Below is the list of all of the inverters Fault IDs and their associated Faults:

Fault Name	Fault ID	Fault Name	Fault ID
Central Cap Over Voltage Fault	1	Internal Fault	80
Battery Port Over Voltage Fault	2	LCD Communication Loss Fault	82
Battery Port Over Current Fault	3	Calibration Load Fault	85
PV Port Over Voltage Fault	4	Communication Loss Fault	86

PV Port Over Current Fault	5	Master Command Loss Fault	96
Grid Port Over Current Fault	6	Synch Signal Loss Fault	97
Setup Wizard Fault	7	Grid Contactor Fault	98
DC Port Reverse Voltage Fault	8	GFDI Error Fault	99
Ground Fault	9	Fan VSD Failure	100
Central Cap Under Voltage (Inst.)	10	Wrong Phase Order Fault	103
IGBT Bridge Error	11	Grid Over Voltage Fault (Slow)	104
Inverter Over Voltage Fault	12	Grid Port Startup Timeout	105
Grid Port Over Voltage Fault (Inst.)	13	Battery Over Voltage Fault	113
Internal Fault	16	Battery Under Voltage Fault	114
Inverter Overload Fault	18	Battery Over Temperature Fault	115
Central Cap Under Voltage Fault (Slow)	19	Battery Over Charge Capacity Fault	116
Inverter Over Temperature Fault	33	Battery Pre-charge Timeout Fault	117
Inverter Temp Sensor Failure	34	Battery Under Temperature Fault	118
Loss of signal fault	53	Battery Over Charge Current Fault	119
User-defined Trip	65	Battery Current Sensor Failure	120
External Trip	66	PV to Battery Short Fault	121
Internal Fault	67	Synchronization to Master Fault (Backup Mode)	128
Max Retries Fault	68	PV Over Voltage Fault	129
Bootup Fault	70	PV Backfeed Fault	132

Figure 3-24: System Faults and ID's

[System Tripped]	Parameter #	2201
	Type	 
	Range	0 System not tripped 1 System tripped
	Default	1

This parameter will be equal to 1 when the inverter is in the “Tripped” state. Otherwise it will be equal to 0. This parameter can be mapped to a digital output so it can be monitored by a remote system.

Central Cap Over Voltage Fault

This fault will be issued when the central cap voltage is too high to maintain the proper operation.

Battery Port Over Voltage Fault

This fault will be issued when the battery port voltage is too high to maintain the proper operation.

Battery Port Over Current Fault

This fault will be issued when the battery port current is too high to maintain the proper operation.

PV Port Over Voltage Fault

This fault will be issued when the PV port voltage is too high to maintain the proper operation.

PV Port Over Current Fault

This fault will be issued when the PV port current is too high to maintain the proper operation.

Grid Port Over Current Fault

This fault will be issued when the grid port current is too high to maintain the proper operation.

Setup Wizard Fault

If the user has not completed the setup wizard, the inverter will issue the Setup Wizard Fault when it receives the On signal. The setup wizard must be completed before the inverter can be run.

Ground Fault

This fault will be issued if the ground fault detection circuit measured a ground current of more than 4 amps or determined that the ground fuse is blown.

Central Cap Under Voltage Fault

This fault will be issued when the central cap voltage is too low to maintain the proper operation.

IGBT Bridge Error Fault

This fault will be issued if the AC IGBT bridge detected a fault and latched the error signal.

Inverter Over Voltage Fault

This fault will be issued when the internal inverter AC voltage is too high to maintain the proper operation.

Grid Port Over Voltage Fault

This fault will be issued when the grid port voltage is too high to maintain the proper operation.

Internal Faults









Internal faults happen because of a hardware fault. If an internal fault is detected, reset the inverter and restart it. If problem persists, contact technical support.

Inverter Overload Fault

This fault will be issued if the inverter AC current is above 103% of maximum current for enough time that the overload accumulator reaches the overload limit. The overload limit is set such that running at 110% of the maximum current for 1 minute will cause an overload fault. The accumulator is added to by an amount that is proportional to the square of current, so running at 120% of the threshold will trip the inverter in 15 seconds, and so on.

Inverter Over Temperature Fault

This fault will be issued if the measured temperature either of the input switching heat sink or of the output switching heat sink exceeds 105C, or the ambient temperature exceeds 70C. The heat sink and ambient temperatures are stored in **[Bat Heatsink Temperature]**, **[PV Heatsink Temp]**, **[Grid Heatsink Temperature]** and **[Ambient Temperature]** respectively.

[Bat Heatsink Temperature]	Parameter #	2213
	Type	 
	Range	[-273. . . 175]
	Default	0
[PV Heatsink Temperature]	Parameter #	2228
	Type	 
	Range	[-273 . . . 175]
	Default	0
[Grid Heatsink Temperature]	Parameter #	2218
	Type	 
	Range	[-273. . . 175]
	Default	0
[Ambient Temperature]	Parameter #	2223
	Type	 
	Range	[-273 . . . 175]
	Default	0
[Temperature Analog Lo]	Parameter #	2211
	Type	
	Range	[-273 . . . 175]
	Default	0
[Temperature Analog Hi]	Parameter #	2212

	Type	Write-USER
	Range	[-273 . . . 175]
	Default	120

These parameters define the analog output mapping range for [**Bat Heatsink Temperature**], [**PV Heatsink Temp**], [**Grid Heatsink Temperature**] and [**Ambient Temperature**].

Inverter Temp Sensor Failure

This fault will be issued if the control system detects that one of the temperature sensors is not working properly. This could be caused by damage to the sensor cables or an accidental disconnection at the sensor (located at the heat sink) or at the control board.

Loss of signal fault

If signal loss detection is enabled for a particular analog input, a Loss of Signal Fault will be issued if the measured reference signal on that input goes below [**AIx Signal Lo**]-5%. To enable signal loss detection for an analog input, set the corresponding bit in the [**Signal Loss Enable**] parameter to 1. Note: in order to use signal loss detection, [**AIx Signal Lo**] for the desired analog input must be set greater than 5%. A common configuration for loss detection is to use the range 2-10V or 4-20mA instead of 0-10V and 0-20mA. This configuration uses [**AIx Signal Lo**] = 20% and [**AIx Signal Hi**] = 100%.

[Signal Loss Enable]	Parameter #	2203
	Type	Write-USER BIN CWR
	Range	[0000000000000000. . . 000000000000111]
	Default	0000000000000000

The first 3 bits of the parameter [**Signal Loss Enable**] each determine whether or not signal loss detection is enabled for one analog input. Signal loss detection is enabled if a bit is 1, and disabled if the bit is 0.

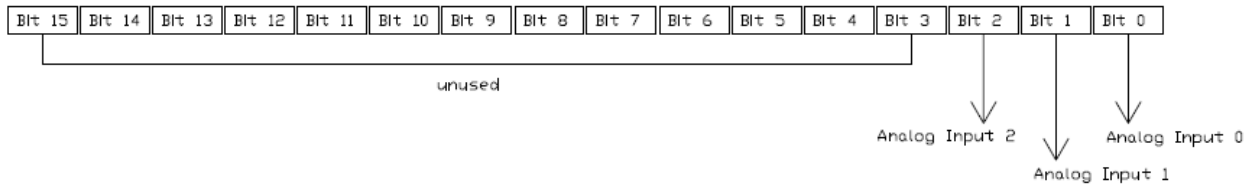

User-defined Trip

This fault is configurable by the user such that the system can trip based on a custom set of conditions. The user is able to choose any system parameter, and set up a threshold such that the inverter will trip if the selected parameter is either above or below that threshold.

[User Trip Parameter ID]	Parameter #	2205
	Type	Write-USER
	Range	[0 . . . 2864]
	Default	0

Enter the parameter ID for the parameter that the User-Defined Trip will be based on.

[User Trip Threshold]	Parameter #	2206
	Type	<input type="checkbox"/> Write-USER <input type="checkbox"/> CWR
	Range	[0 . . 100] %
	Units	.01 %
	Default	70%

This parameter defines the threshold to which the User Trip Parameter will be compared. It is defined as a % of the maximum value of this parameter. For example, if the user wants the inverter to trip when the input heat sink temperature reaches 60C, since the maximum for **[Bat Heatsink Temperature]** is 175C, **[User Trip Threshold]** should be set to **34.28%**. This is because 60C is 34.28% of 175.

[User Trip Greater/Less]	Parameter #	2207
	Type	<input type="checkbox"/> Write-USER <input type="checkbox"/> CWR
	Range	0 Trip when less than threshold 1 Trip when greater than threshold
	Default	1

If the user wants the inverter to trip when the User Trip Parameter is above the threshold defined by **[User Trip Threshold]**, this parameter should be set to 1. If this parameter is set to 0, the inverter will trip when the User Trip Parameter is below the threshold.

[User Trip Enable]	Parameter #	2208
	Type	<input type="checkbox"/> Write-USER <input type="checkbox"/> CWR
	Range	0 Disabled 1 Enabled
	Default	0

To enable the User-Defined Trip, set this parameter to 1. To disable it, set it to 0.

External Trip

If **[External Trip]** parameter is set to 1, the inverter will issue an External Trip fault. This parameter can be mapped to a digital input so that it can be controlled by a remote system.

[External Trip]	Parameter #	2202
	Type	<input type="checkbox"/> Write-OPEN <input type="checkbox"/> CWR <input type="checkbox"/> DIn <input type="checkbox"/> DOut
	Range	0 No Action 1 Trip
	Default	0

Max Retries Fault

This fault will be issued if the inverter has attempted, unsuccessfully, to restart after a fault a number of times equal to **[Auto Restart Attempts]**. Inverter will stay tripped until user resets it.

Bootup Fault

If the CRC of stored configuration parameters is not correct, system will indicate a fault and load the default values. This requires re-configuring all inverter parameters, loading the backup parameters from the front panel interface unit, or loading a saved profile via the Web Interface. The inverter must be reset in order to clear this fault.

LCD Communication Loss Fault

This fault is issued if the inverter loses communication with the front panel interface (LCD).

Calibration Load Fault

Unit specific calibration data has been lost due to an error in the control system. Inverter cannot operate without this data. Contact the technical support if this fault occurs.

Communication Loss

This fault will be issued if communication is lost with an external controller. To enable the fault, **[Communication Watchdog Enable]** needs to be set to 1. Parameter **[Communication Watchdog]** needs to be periodically written with some value. If nothing is written into **[Communication Watchdog]** parameter for a period of time specified by the **[Communication Watchdog Timeout]**, the inverter will issue the Communication Loss Fault.

[Communication Watchdog Enable]	Parameter #	2253
	Type	<input checked="" type="checkbox"/> Write-OPEN <input type="checkbox"/> CWR
	Range	0 Disable 1 Enable
	Default	0

[Communication Watchdog]	Parameter #	2254
	Type	<input checked="" type="checkbox"/> Write-OPEN <input type="checkbox"/> CWR
	Range	-32768...32768
	Default	0

[Communication Watchdog Timeout]	Parameter #	2255
	Type	<input checked="" type="checkbox"/> Write-OPEN <input type="checkbox"/> CWR
	Range	0.1...3200
	Units	Seconds
	Default	5

Master Command Loss Fault

This fault will be issued if the inverter stops receiving the command signal sent by the master unit.

Synch Signal Loss

This fault will be issued if the inverter stops receiving the synchronization signal sent by the master unit. If this fault is issued on a stand-alone unit, it may indicate a problem with the jumper cable between J40 and J46 on the GTI interface I/O board on the inside of the door of the inverter.

Grid Contactor Fault

This fault will be issued if the control system detects that the grid contactor failed to operate properly.

GFDI Error Fault

This fault will be issued if the control system detects that the Ground Fault Detector/Interrupter unit is not operating properly.

Fan VSD Failure

This fault will be issued if the control system detects that the VSD that controls the inverter blowers failed to operate properly.

PV Control Fault Definitions

The following faults are only applicable if the inverter configured for PV operation.

PV Over Voltage Fault

This fault will be issued when the PV array voltage is too high to maintain the proper operation.

PV Backfeed Fault

This fault will be issued if there is current flowing from the PV port into the PV array.

Battery Control Fault Definitions

[\[Battery Overcharge Fault Enable\]](#)

[\[Battery Total Charge Capacity\]](#)

[\[Battery Overcharge Threshold%\]](#)

[\[Battery Over Temperature Fault Threshold\]](#)

[\[Battery Over Temperature Fault Time\]](#)

[\[Battery Over Temperature Clear Threshold\]](#)

[\[Battery Over Temperature Clear Time\]](#)

[\[Battery Under Temperature Fault Threshold\]](#)

[\[Battery Under Temperature Fault Time\]](#)

[\[Battery Under Temperature Clear Threshold\]](#)

[\[Battery Under Temperature Clear Time\]](#)

The following faults are only applicable if the inverter configured for Battery operation.

Battery Over Voltage Fault

This fault will be issued when the battery voltage is too high to maintain the proper operation.

Battery Under Voltage Fault

This fault will be issued when the battery voltage is too low to maintain the proper operation.

Battery Over Temperature Fault

This fault will be issued when the battery temperature exceeds the user set **[Battery Over Temperature Fault Threshold]** parameter for a period of time controlled by **[Battery Over Temperature Fault Time]** parameter. The trip self clears if the battery temperature goes below **[Battery Over Temperature Clear Threshold]** parameter for a period of time controlled by **[Battery Over Temperature Clear Time]** parameter.

[Battery Over Temperature Fault Threshold]	Parameter #	2407
	Type	<input type="checkbox"/> Write-USER <input type="checkbox"/> CWR
	Range	[-273 . . . 175]
	Default	70

[Battery Over Temperature Fault Time]	Parameter #	2408
	Type	<input type="checkbox"/> Write-USER <input type="checkbox"/> CWR
	Range	[0.01 . . . 10]
	Default	1

[Battery Over Temperature Clear Threshold]	Parameter #	2409
	Type	<input type="checkbox"/> Write-USER <input type="checkbox"/> CWR
	Range	[-273 . . . 175]
	Default	60

[Battery Over Temperature Clear Time]	Parameter #	2410
	Type	<input type="checkbox"/> Write-USER <input type="checkbox"/> CWR
	Range	[0.01 . . . 10]
	Default	1

Battery Over Charge Capacity Fault

This fault will be issued if the inverter exceeds the battery charge capacity (amp-hours) when in battery charging mode.

[Battery Overcharge Fault Enable]	Parameter #	2415
	Type	<input type="checkbox"/> Write-USER
	Range	[0, 1]
	Default	0

Set this parameter to 1 to enable the fault, otherwise set it to 0.

[Battery Total Charge Capacity]	Parameter #	2416
	Type	<input type="checkbox"/> Write-USER <input type="checkbox"/> CWR
	Range	[0 . . . 32000]
	Default	100

Total battery charge capacity in amp-hours.

[Battery Overcharge Threshold%]	Parameter #	2417
	Type	<input type="checkbox"/> Write-USER <input type="checkbox"/> CWR
	Range	[0 . . . 320]
	Default	1.25

This parameter defines the threshold for the Battery Over Charge Capacity Fault. The inverter will issue the trip if total charge amount will exceed **[Battery Total Charge Capacity]x[Battery Overcharge Threshold%]**.

Battery Pre-charge Timeout Fault

This fault will be issued if the central cap does not pre-charge within a set time period after the DC disconnect has been closed.

Battery Under Temperature Fault

This fault will be issued when the battery temperature goes below the user set **[Battery Under Temperature Fault Threshold]** parameter for a period of time controlled by **[Battery Under Temperature Fault Time]** parameter. The trip self clears if the battery temperature goes above **[Battery Under Temperature Clear Threshold]** parameter for a period of time controlled by **[Battery Under Temperature Clear Time]** parameter.

[Battery Under Temperature Fault Threshold]	Parameter #	2411
	Type	<input type="checkbox"/> Write-USER <input type="checkbox"/> CWR
	Range	[-273 . . . 175]
	Default	-10

[Battery Under Temperature Fault Time]	Parameter #	2412
	Type	<input type="checkbox"/> Write-USER <input type="checkbox"/> CWR
	Range	[0.01 . . . 10]
	Default	1

[Battery Under Temperature Clear Threshold]	Parameter #	2413
	Type	<input type="checkbox"/> Write-USER <input type="checkbox"/> CWR
	Range	[-273 . . . 175]
	Default	0

[Battery Under Temperature Clear Time]	Parameter #	2414
	Type	<input type="checkbox"/> Write-USER <input type="checkbox"/> CWR
	Range	[0.01 . . . 10]
	Default	1

Battery Over Charge Current Fault

This fault will be issued if battery current exceeds the current specified by the **[Maximum Charging Current]** during charging.

Battery Current Sensor Failure

This fault will be issued if inverter detects that the battery current sensor is malfunctioning and providing invalid readings.

PV to Battery Short Fault

This fault will be issued if there is current flowing through the battery port when inverter is not active indicating a possible PV port to Battery port short.

Grid Control Faults

The following faults are only applicable if the inverter is operating in on-grid mode.

Wrong Phase Order Fault

This fault will be issued when the inverter detects incorrect phase order at either the grid terminal or the isolation transformer terminals.

Backup Control Faults

The following faults are only applicable if the inverter is operating in on-grid mode.

Synchronization to Master Fault (Backup Mode)

This fault will be issued when the inverter is operating in backup mode and loses synchronization with the master unit.

Fault Buffer

[\[Fault Buffer X - Fault ID\]](#)
[\[Fault Buffer X - Fault Time\]](#)
[\[Fault Buffer X - Fault Date\]](#)
[\[Fault Buffer X - Battery voltage\]](#)
[\[Fault Buffer X - Battery current Inst\]](#)
[\[Fault Buffer X - Battery current Avg\]](#)
[\[Fault Buffer X - PV voltage\]](#)
[\[Fault Buffer X - PV current Inst\]](#)

[\[Fault Buffer X - PV current Avg\]](#)
[\[Fault Buffer X - AC voltage\]](#)
[\[Fault Buffer X - AC Current Inst\]](#)
[\[Fault Buffer X - AC Current Avg\]](#)
[\[Fault Buffer X - Central Cap Voltage\]](#)
[\[Fault Buffer X - Status Register 1\]](#)
[\[Fault Buffer X - Status Register 2\]](#)
[\[Fault Buffer X - Alarm Status Register\]](#)

Every time a Fault is issued, the following 16 system values are stored to memory for later reference. The system stores up to 4 sets of these values. After 4 sets have been stored, when a new Fault is issued, the oldest set is deleted to make room for the newest set.

[Fault Buffer 0 - Fault ID] . . . [Fault Buffer 3 - Fault ID]	Parameter #	2801, 2817, 2833, 2849
	Type	Read Only
	Range	[-32768 . . . 32767]
	Default	0

[Fault Buffer 0 - Fault Time] . . . [Fault Buffer 3 - Fault Time]	Parameter #	2802, 2818, 2834, 2850
	Type	Read Only
	Range	[0 . . . 2359]
	Default	0

[Fault Buffer 0 - Fault Date] . . . [Fault Buffer 3 - Fault Date]	Parameter #	2803, 2819, 2835, 2851
	Type	Read Only
	Range	[0 . . . 1231]
	Default	0

[Fault Buffer 0 - Battery voltage] . . . [Fault Buffer 3 - Battery voltage]	Parameter #	2804, 2820, 2836, 2852
	Type	Read Only
	Range	[-3276.8 . . . 3276.7]
	Default	0

[Fault Buffer 0 - Battery current Inst] .	Parameter #	2805, 2821, 2837, 2853
	Type	Read Only
	Range	[-3276.8 . . . 3276.7]

. . . [Fault Buffer 3 - Battery current Inst]	Default	0
--	---------	---

[Fault Buffer 0 - Battery current Avg] [Fault Buffer 3 - Battery current Avg]	Parameter #	2806, 2822, 2838, 2854
	Type	Read Only
	Range	[-3276.8 . . . 3276.7]
	Default	0

[Fault Buffer 0 - PV voltage] [Fault Buffer 3 - PV voltage]	Parameter #	2807, 2823, 2839, 2855
	Type	Read Only
	Range	[-3276.8 . . . 3276.7]
	Default	0

[Fault Buffer 0 - PV current Inst] [Fault Buffer 3 - PV current Inst]	Parameter #	2808, 2824, 2840, 2856
	Type	Read Only
	Range	[-3276.8 . . . 3276.7]
	Default	0

[Fault Buffer 0 - PV current Avg] [Fault Buffer 3 - PV current Avg]	Parameter #	2809, 2825, 2841, 2857
	Type	Read Only
	Range	[-3276.8 . . . 3276.7]
	Default	0

[Fault Buffer 0 - AC voltage] [Fault Buffer 3 - AC voltage]	Parameter #	2810, 2826, 2842, 2858
	Type	Read Only
	Range	[-3276.8 . . . 3276.7]
	Default	0

[Fault Buffer 0 - AC Current Inst] [Fault Buffer 3 - AC Current Inst]	Parameter #	2811, 2827, 2843, 2859
	Type	Read Only
	Range	[-3276.8 . . . 3276.7]
	Default	0

[Fault Buffer 0 - AC Current Avg] . . . [Fault Buffer 3 - AC Current Avg]	Parameter #	2812, 2828, 2844, 2860
	Type	Read Only
	Range	[-3276.8 . . . 3276.7]
	Default	0

[Fault Buffer 0 - Central Cap Voltage] . . . [Fault Buffer 3 - Central Cap Voltage]	Parameter #	2813, 2829, 2845, 2861
	Type	Read Only
	Range	[-3276.8 . . . 3276.7]
	Default	0

[Fault Buffer 0 - Status Register 1] . . . [Fault Buffer 3 - Status Register 1]	Parameter #	2814, 2830, 2846, 2862
	Type	Read Only
	Range	[-32768 . . . 32767]
	Default	0

[Fault Buffer 0 - Status Register 2] . . . [Fault Buffer 3 - Status Register 2]	Parameter #	2815, 2831, 2847, 2863
	Type	Read Only
	Range	[-32768 . . . 32767]
	Default	0

[Fault Buffer 0 - Alarm Status Register] . . . [Fault Buffer 3 - Alarm Status Register]	Parameter #	2816, 2832, 2848, 2864
	Type	Read Only
	Range	[-32768 . . . 32767]
	Default	0

This page intentionally left blank.

4 Maintenance

There are no user serviceable parts in the Inverter. All maintenance must be done by trained and certified Electricians or Technicians. Periodic maintenance should include cleaning and replacing filters, examining interconnections, data log reviews and physical cleaning at least every 6 months. Your service installer should be able to provide optional maintenance plan information. Safe installation is to be per standard product specifications, NEC compliance and per AHJ regulations. **Failure to perform periodic maintenance may void your warranty.**

Airflow

Maintain an unobstructed airflow into and out of the BIGI-250.

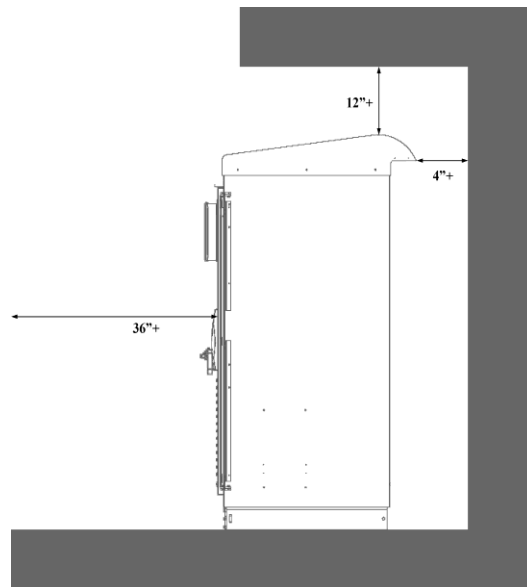

Figure 4-1. Ventilation Clearances

Nothing should be placed or stored on top of the inverter (if it has been installed without a roof) or on the enclosure roof where it could block the exhaust vents.

Similar precautions should be taken regarding the air inlet vents on the front of the unit.

A minimum distance of 12 inches (300mm) must be clear above the inverter for ventilation.

A minimum distance of 36 inches (900mm) must be clear in front of the inverter to allow for opening of the main door.

The inverter must be mounted with at least a 4" open space behind it if the inverter has the roof installed (see Figure 4-1).

Access to the Interior of the Inverter

Make sure that the inverter doors are locked at all times that it is not being serviced by a qualified technician.

Make sure that there is a minimum of 36 inches (900mm) clearance in front of the inverter to allow for opening of the main door.

Data Log Reviews

Data log reviews should be performed at least every six months.

This page intentionally left blank.

A Specifications

BIGI-250 Specifications

General Specifications	
Inverter Technology	High-frequency PWM
Size Inches	90.5 W x 41 D x 70 H
PV Port Input Specifications	
DC Voltage	250-750 VDC (UL Certified to 600 VDC)
DC Maximum Power Voltage	390-750 VDC (UL Certified to 600 VDC)
Max Current	640A
PV MPPT	280-580 VDC
PV Array Configuration	With Isolation Transformer: Negative grounded
Battery Port Input Specifications	
DC Voltage	250-750 VDC (UL Certified to 600 VDC)
DC Maximum Power Voltage	390-750 VDC (UL Certified to 600 VDC)
Max Current (Charge/discharge)	640A
Charging Profile	3-stage, programmable
BMS Compatible	Modbus over RS485 or TCP/IP, CANbus, custom
DC Voltage Ripple	< 1%
Grid Port Specifications	
AC Line Voltage	480 VAC +10%, -12%, 3-phase
AC Line Frequency	60/50 Hz nominal 57-60.5/47-50.5 Hz range (field adjustable)
Continuous AC Current	325 A RMS
Continuous AC Power	250kVA
Power Factor	0 to 1 adjustable (leading and lagging)
Current Harmonics	IEEE 1547 Compliant, <5% THD
Environmental Specifications	
Temperature Operating	0° to 30°C
Storage	-20° to 60°C
Humidity	5-95% (non-condensing)
Cooling	Forced-air cooled
Rated Max Elevation	6,000 Feet
Enclosure	NEMA 1R (Indoor)

(continued)

Safety Features	
Faults	Over/Under-Voltage, Over/Under-Frequency, Over Current, Over-load, Over-Temperature
Standards Compliance	IEEE 1547, CEC, UL 1741 *Pending
Safety Features	Anti-islanding (grid fault detection, isolation & auto-reconnect) UL-compliant trip points (field adjustable)
User Interface Features	
Front-Panel Interface	4x20 LCD, Keypad, Fault LED's
Communication	We offer a wide variety of communication options
Performance Monitoring	Real-time & Historic, web-based performance data
Analog & Digital I/O	Analog: (3) inputs, (1) output; 0-10V or 4-20mA Digital: (2) inputs 0-24V, (2) output relays
Efficiency	
Peak Efficiency	96.5%
CEC Efficiency	95.0%
Nighttime TARE Losses	175W
Energy-saving Features	Automatic internal subsystems power-down, Nighttime transformer auto-disconnect

Table 0-1: BIGI-250 Specifications

This page intentionally left blank.

B BIGI-250 Parameter List

Table of Parameters

The following table contains all of the system parameters, sorted by ID number.

Parameter Name	ID	Group	Min	Max	Scale	Units
[FPGA Firmware V#]	101	System Info	0	327.67	0.01	
[DSP Firmware V#]	102	System Info	0	327.67	0.01	
[DSP Product Type]	103	System Info	0	32767	1	
[DSP kW Macro]	104	System Info	0	32767	1	
[Parameter List V#]	105	System Info	0	32767	1	
[WebUI Driver V#]	106	System Info	0	327.67	0.01	
[Applet V#]	107	System Info	0	327.67	0.01	
[LCD Menu V#]	108	System Info	0	327.67	0.01	
[LCD Product Type]	109	System Info	0	32767	1	
[LCD Driver V#]	110	System Info	0	327.67	0.01	
[Setup Wizard Done]	111	System Info	0	1	1	
[LCD Display Param ID1]	201	LCD	0	3020	1	
[LCD Display Param ID2]	202	LCD	0	3020	1	
[LCD Display Param ID3]	203	LCD	0	3020	1	
[LCD Display Param ID4]	204	LCD	0	3020	1	
[LCD Display Param ID5]	205	LCD	0	3020	1	
[LCD Display Param ID6]	206	LCD	0	3020	1	
[LCD Display Param ID7]	207	LCD	0	3020	1	
[LCD Display Param ID8]	208	LCD	0	3020	1	
[LCD Display Param ID9]	209	LCD	0	3020	1	
[LCD Display Param ID10]	210	LCD	0	3020	1	
[LCD Display Param ID11]	211	LCD	0	3020	1	
[LCD Display Param ID12]	212	LCD	0	3020	1	
[LCD Display Param ID13]	213	LCD	0	3020	1	
[LCD Display Param ID14]	214	LCD	0	3020	1	
[LCD Display Param ID15]	215	LCD	0	3020	1	
[LCD Display Param ID16]	216	LCD	0	3020	1	
[LCD Display Param ID17]	217	LCD	0	3020	1	
[LCD Display Param ID18]	218	LCD	0	3020	1	
[LCD Display Param ID19]	219	LCD	0	3020	1	
[LCD Display Param ID20]	220	LCD	0	3020	1	
[LCD Indiv Param ID]	221	LCD	0	3020	1	
[LCD Operation Timer]	222	LCD	0	32767	1	sec
[Device ID]	301	Modbus	1	247	1	
[Baud Rate]	302	Modbus	4800	57600	10	bps

Appendix B: BIGI-250 Parameter List

[Data bits]	303	Modbus	7	8	1	
[Parity]	304	Modbus	0	2	1	
[Stop bits]	305	Modbus	1	2	1	
[RS-232/485 Select]	306	Modbus	0	1	1	
[DHCP Enable]	401	Web UI	0	1	1	
[IP Address MSB]	402	Web UI	0	255	1	
[IP Address Byte 3]	403	Web UI	0	255	1	
[IP Address Byte 2]	404	Web UI	0	255	1	
[IP Address LSB]	405	Web UI	0	255	1	
[Subnet Mask MSB]	406	Web UI	0	255	1	
[Subnet Mask Byte 3]	407	Web UI	0	255	1	
[Subnet Mask Byte 2]	408	Web UI	0	255	1	
[Subnet Mask LSB]	409	Web UI	0	255	1	
[Gateway MSB]	410	Web UI	0	255	1	
[Gateway Byte 3]	411	Web UI	0	255	1	
[Gateway Byte 2]	412	Web UI	0	255	1	
[Gateway LSB]	413	Web UI	0	255	1	
[E-mail Trip Data Enable]	414	Web UI	0	1	1	
[Password]	501	Password Protection	0	32767	1	
[User Set Password]	502	Password Protection	0	32767	1	
[Factory Set Password]	503	Password Protection	0	32767	1	
[Inverter Control Mode]	601	Inverter Configuration	0	1	1	
[Microgrid Mode Enable]	602	Inverter Configuration	0	1	1	
[Inverter Grid Mode]	603	Inverter Configuration	0	2	1	
[Auto Grid Contactor Control Enable]	604	Inverter Configuration	0	1	1	
[Manual Grid Contactor On]	605	Inverter Configuration	0	1	1	
[Nominal Frequency Select]	606	Inverter Configuration	0	1	1	
[Nominal Voltage]	607	Inverter Configuration	10	528	0.1	V
[Reactive Power Control Enable]	608	Inverter Configuration	0	1	1	
[Inverter On]	701	Inverter Control	0	1	1	

Appendix B: BIGI-250 Parameter List

[Inverter Reset]	702	Inverter Control	0	1	1	
[Battery Port Enable]	703	Inverter Control	0	1	1	
[PV Port Enable]	704	Inverter Control	0	1	1	
[Grid Port Enable]	705	Inverter Control	0	1	1	
[Power Command]	706	Inverter Control	-300	300	0.1	kW
[Reactive Power Command]	707	Inverter Control	-300	300	0.1	kVar
[Power Command Analog Lo]	708	Inverter Control	-400	400	0.1	kW
[Power Command Analog Hi]	709	Inverter Control	-400	400	0.1	kW
[Run On Power Up]	710	Inverter Control	0	1	1	
[Pulse Limit]	711	Inverter Control	0	9999	1	
[Grid AC Voltage AB]	801	Monitoring	0	3200	0.1	V
[Grid AC Voltage BC]	802	Monitoring	0	3200	0.1	V
[Grid AC Voltage CA]	803	Monitoring	0	3200	0.1	V
[Grid AC Voltage Analog Lo]	804	Monitoring	0	3200	0.1	V
[Grid AC Voltage Analog Hi]	805	Monitoring	0	3200	0.1	V
[Inverter AC Voltage]	806	Monitoring	0	3200	0.1	V
[Inverter AC Voltage Analog Lo]	807	Monitoring	0	3200	0.1	V
[Inverter AC Voltage Analog Hi]	808	Monitoring	0	3200	0.1	V
[Inverter AC Current]	809	Monitoring	0	3200	0.1	Amps
[Inverter AC Current Analog Lo]	810	Monitoring	0	3200	0.1	Amps
[Inverter AC Current Analog Hi]	811	Monitoring	0	3200	0.1	Amps
[Inverter AC Power Real]	812	Monitoring	-3200	3200	0.1	kW
[Inverter AC Power Reactive]	813	Monitoring	-3200	3200	0.1	kVar
[AC Power Analog Lo]	814	Monitoring	-3200	3200	0.1	kW
[AC Power Analog Hi]	815	Monitoring	-3200	3200	0.1	kW
[AC Bridge Current]	816	Monitoring	0	3200	0.1	Amps
[AC Bridge Current Analog Lo]	817	Monitoring	0	3200	0.1	Amps
[AC Bridge Current Analog Hi]	818	Monitoring	0	3200	0.1	Amps
[Battery Voltage]	819	Monitoring	0	3200	0.1	V
[Battery Voltage Analog Lo]	820	Monitoring	0	3200	0.1	V
[Battery Voltage Analog Hi]	821	Monitoring	0	3200	0.1	V
[Battery Current]	822	Monitoring	0	3200	0.1	Amps

Appendix B: BIGI-250 Parameter List

[Battery Current Analog Lo]	823	Monitoring	0	3200	0.1	Amps
[Battery Current Analog Hi]	824	Monitoring	0	3200	0.1	Amps
[Battery Power]	825	Monitoring	-3200	3200	0.1	kW
[Battery Power Analog Lo]	826	Monitoring	-3200	3200	0.1	kW
[Battery Power Analog Hi]	827	Monitoring	-3200	3200	0.1	kW
[Battery State of Charge]	828	Monitoring	0	100	0.01	%
[PV Voltage]	829	Monitoring	0	3200	0.1	V
[PV Voltage Analog Lo]	830	Monitoring	0	3200	0.1	V
[PV Voltage Analog Hi]	831	Monitoring	0	3200	0.1	V
[PV Current]	832	Monitoring	0	3200	0.1	Amps
[PV Current Analog Lo]	833	Monitoring	0	3200	0.1	Amps
[PV Current Analog Hi]	834	Monitoring	0	3200	0.1	Amps
[PV Power]	835	Monitoring	-3200	3200	0.1	kW
[PV Power Analog Lo]	836	Monitoring	-3200	3200	0.1	kW
[PV Power Analog Hi]	837	Monitoring	-3200	3200	0.1	kW
[Central Cap Voltage]	838	Monitoring	0	3200	0.1	V
[Frequency Command]	839	Monitoring	0	320	0.01	Hz
[PV Minimum Power]	901	PV Control Settings	0	320	0.01	kW
[PV Minimum Power Time]	902	PV Control Settings	0	32000	1	sec
[PV Restart Time]	903	PV Control Settings	0	32000	1	sec
[PV Minimum Voltage]	904	PV Control Settings	0	3200	0.1	V
[PV MPPT Voltage Limit]	905	PV Control Settings	0	3200	0.1	V
[MPPT Gamma]	906	PV Control Settings	0	1	0.01	
[MPPT Ripple Amplitude]	907	PV Control Settings	0	320	0.01	V
[MPPT Ripple Frequency]	908	PV Control Settings	0	320	0.01	Hz
[DC Damping Rsim]	909	PV Control Settings	0	320	0.01	Ohm
[PV Array Open Circuit Voltage]	910	PV Control Settings	0	3200	0.1	V
[PV kWh Today]	911	PV Control Settings	0	32000	1	kWh
[Reset kWh Today]	912	PV Control Settings	0	1	1	
[PV Total kWh]	913	PV Control	0	32000	1	kWh

Appendix B: BIGI-250 Parameter List

		Settings				
[PV Total MWh]	914	PV Control Settings	0	32000	1	MWh
[Reset Total kWh]	915	PV Control Settings	0	1	1	
[Reset Date MMDD]	916	PV Control Settings	0	32000	1	
[Reset Date YY]	917	PV Control Settings	0	32000	1	
[IldcT0NextTarget Cap]	918	PV Control Settings	0	100	0.01	%
[Bulk Charging Voltage]	1001	Battery Control Settings	20	600	0.1	V
[Float Charging Voltage]	1002	Battery Control Settings	20	600	0.1	V
[Maximum Charging Current]	1003	Battery Control Settings	-10	650	0.1	Amps
[Bulk to Float Transition Current]	1004	Battery Control Settings	0	650	0.1	Amps
[Battery Charged Current]	1005	Battery Control Settings	0	650	0.1	Amps
[Battery Not Charged Voltage]	1006	Battery Control Settings	20	620	0.1	V
[Minimum Discharge Voltage]	1007	Battery Control Settings	10	600	0.1	V
[Rectifier Used For Testing]	1008	Battery Control Settings	0	1	1	
[Battery Equalization Enable]	1009	Battery Control Settings	0	1	1	
[Battery Equalization Voltage]	1010	Battery Control Settings	20	600	0.1	V
[Battery Equalization Time Hours]	1011	Battery Control Settings	0	3600	1	Hours
[Battery Equalization Time Minutes]	1012	Battery Control Settings	0	60	1	Min
[Bulk Delay Time Hours]	1013	Battery Control Settings	0	3600	1	Hours
[Bulk Delay Time Minutes]	1014	Battery Control Settings	0	60	1	Min
[Battery Temperature]	1015	Battery Control Settings	-273	320	0.01	C
[Battery Temp Analog Lo]	1016	Battery Control Settings	-273	320	0.01	C

		Settings				
[Battery Temp Analog Hi]	1017	Battery Control Settings	-273	320	0.01	C
[Temperature Compensation Enable]	1018	Battery Control Settings	0	1	1	
[Temperature Compensation Per Cell]	1019	Battery Control Settings	0	1	0.0001	V/C
[Number of Cells]	1020	Battery Control Settings	0	32000	1	
[T1 Gain Scale]	1021	Battery Control Settings	0	32	0.001	
[Bulk Time Out]	1022	Battery Control Settings	0	320	0.01	Hours
[IbatTO Filter %]	1023	Battery Control Settings	0	100	0.01	%
[Battery Minimum Voltage Limit]	1024	Battery Control Settings	0	1000	0.1	V
[Maximum Current Disable]	1025	Battery Control Settings	0	1	1	
[Battery Charging Voltage Limit]	1026	Battery Control Settings	0	1000	0.1	V
[Generator On Command]	1027	Battery Control Settings	0	1	1	
[Generator On Voltage]	1028	Battery Control Settings	0	600	0.1	V
[Generator Off Voltage]	1029	Battery Control Settings	0	600	0.1	V
[Maximum Discharging Current]	1030	Battery Control Settings	-10	650	0.1	Amps
[Battery Charged]	1031	Battery Control Settings	0	1	1	
[Battery Discharged]	1032	Battery Control Settings	0	1	1	
[AI Minimum Frequency]	1101	Grid Control Settings	-5	5	0.01	Hz
[AI Maximum Frequency]	1102	Grid Control Settings	-5	5	0.01	Hz
[AI Outer Frequency Window Time]	1103	Grid Control Settings	0	300	0.01	sec
[AI Sag Frequency]	1104	Grid Control Settings	-3	-0.2	0.01	Hz
[AI Frequency Sag Time]	1105	Grid Control	0.16	300	0.01	sec

Appendix B: BIGI-250 Parameter List

		Settings				
[AI Minimum Voltage]	1106	Grid Control Settings	0	320	0.01	%
[AI Maximum Voltage]	1107	Grid Control Settings	0	320	0.01	%
[AI Outer Voltage Window Time]	1108	Grid Control Settings	0	300	0.01	sec
[AI Sag Voltage]	1109	Grid Control Settings	50	88	0.1	%
[AI Surge Voltage]	1110	Grid Control Settings	110	120	0.1	%
[AI Voltage Sag Time]	1111	Grid Control Settings	0	300	0.01	sec
[AI Voltage Surge Time]	1112	Grid Control Settings	0	300	0.01	sec
[AI Minimum Reconnect Frequency]	1113	Grid Control Settings	-5	5	0.01	Hz
[AI Maximum Reconnect Frequency]	1114	Grid Control Settings	-5	5	0.01	Hz
[AI Minimum Reconnect Voltage]	1115	Grid Control Settings	80	120	0.01	%
[AI Maximum Reconnect Voltage]	1116	Grid Control Settings	80	120	0.01	%
[AI Reconnect Delay]	1117	Grid Control Settings	0	32000	1	sec
[On-grid Minimum Frequency]	1118	Grid Control Settings	-60	60	0.01	Hz
[On-grid Maximum Frequency]	1119	Grid Control Settings	-60	60	0.01	Hz
[On-grid Outer Frequency Window Time]	1120	Grid Control Settings	0	300	0.01	sec
[On-grid Minimum Voltage]	1121	Grid Control Settings	0	320	0.01	%
[On-grid Maximum Voltage]	1122	Grid Control Settings	0	320	0.01	%
[On-grid Outer Voltage Window Time]	1123	Grid Control Settings	0	300	0.01	sec
[On-grid Sag Voltage]	1124	Grid Control Settings	0	320	0.01	%
[On-grid Surge Voltage]	1125	Grid Control Settings	0	320	0.01	%
[On-grid Voltage Sag Time]	1126	Grid Control	0	300	0.01	sec

Appendix B: BIGI-250 Parameter List

		Settings				
[On-grid Voltage Surge Time]	1127	Grid Control Settings	0	300	0.01	sec
[On-grid Reconnect Delay]	1128	Grid Control Settings	0	32000	1	sec
[Power Factor Shift Time]	1129	Grid Control Settings	0	320	0.01	sec
[AI Positive Iq]	1130	Grid Control Settings	-320	320	0.01	Amps
[AI Negative Iq]	1131	Grid Control Settings	-320	320	0.01	Amps
[Anti-islanding Iq Threshold]	1132	Grid Control Settings	0	320	0.01	Amps
[Anti-islanding Frequency Threshold]	1133	Grid Control Settings	0	320	0.01	Hz
[Grid Contactor Close Delay]	1134	Grid Control Settings	0.01	320	0.01	sec
[Phase Loss Minimum Power]	1135	Grid Control Settings	0	300	0.01	kVA
[Phase Loss Current Threshold]	1136	Grid Control Settings	0	320	0.01	Amps
[Phase Loss Trip Time]	1137	Grid Control Settings	0	320	0.01	sec
[Grid Port Power Limit Min]	1138	Grid Control Settings	-275	275	0.1	kW
[Grid Port Power Limit Max]	1139	Grid Control Settings	-275	275	0.1	kW
[Grid Port Power Limit Min Analog Lo]	1140	Grid Control Settings	-275	275	0.1	kW
[Grid Port Power Limit Min Analog Hi]	1141	Grid Control Settings	-275	275	0.1	kW
[Grid Port Power Limit Max Analog Lo]	1142	Grid Control Settings	-275	275	0.1	kW
[Grid Port Power Limit Max Analog Hi]	1143	Grid Control Settings	-275	275	0.1	kW
[Offgrid Voltage Reference]	1201	Backup Control Settings	0	320	0.01	%
[Offgrid Voltage Regulation P-gain]	1202	Backup Control Settings	0	32.767	0.001	
[Offgrid Voltage Regulation I-gain]	1203	Backup Control Settings	0	32.767	0.001	
[Offgrid Voltage Ramp Rate]	1204	Backup Control	0	32000	1	V/sec

Appendix B: BIGI-250 Parameter List

		Settings				
[Offgrid Reactive Power Reference]	1205	Backup Control Settings	-300	300	0.01	kVar
[Offgrid Reactive Power Reg P-gain]	1206	Backup Control Settings	0	32.767	0.001	
[Offgrid Reactive Power Reg I-gain]	1207	Backup Control Settings	0	32.767	0.001	
[Motor Nameplate FLA]	1301	Motor Control Settings	0.1	400	0.1	Amps
[Motor Nameplate Hz]	1302	Motor Control Settings	20	60	0.01	Hz
[Motor Nameplate RPM]	1303	Motor Control Settings	1	3600	1	RPM
[Motor Nameplate Volts]	1304	Motor Control Settings	0.1	500	0.1	V
[Motor Nameplate HP]	1305	Motor Control Settings	0.1	300	0.1	HP
[Motor Min Speed]	1306	Motor Control Settings	20	60	0.01	Hz
[Motor Max Speed]	1307	Motor Control Settings	20	60	0.01	Hz
[Motor Startup Delay]	1308	Motor Control Settings	0	32000	1	sec
[Motor Acceleration Rate]	1309	Motor Control Settings	0.001	32	0.001	Hz/sec
[Motor Deceleration Rate]	1310	Motor Control Settings	0.001	32	0.001	Hz/sec
[Motor Speed Increment]	1311	Motor Control Settings	0.01	60	0.01	Hz
[Motor Speed Decrement]	1312	Motor Control Settings	0.01	60	0.01	Hz
[Motor Speed Interval]	1313	Motor Control Settings	1	32000	1	sec
[Insufficient PV Voltage Threshold]	1314	Motor Control Settings	0.1	600	0.1	V
[Motor Phase Shift Adjustment Gain]	1315	Motor Control Settings	0	10	0.001	
[Motor Rsim]	1316	Motor Control Settings	0	32	0.001	Ohm
[Inverter On Owner]	1401	Control Function Owners	0	15	1	

Appendix B: BIGI-250 Parameter List

[Inverter Reset Owner]	1402	Control Function Owners	0	15	1	
[External Trip Owner]	1403	Control Function Owners	0	15	1	
[Power Command Owner]	1404	Control Function Owners	0	15	1	
[Grid Port Power Limit Owner]	1405	Control Function Owners	0	15	1	
[Inverter Status 1]	1501	Inverter Status	-32768	32767	1	
[Inverter Status 2]	1502	Inverter Status	-32768	32767	1	
[System State]	1503	Inverter Status	-32768	32767	1	
[DI0 Parameter ID]	1601	Digital Inputs	0	3020	1	
[DI1 Parameter ID]	1602	Digital Inputs	0	3020	1	
[Digital Input Invert Mask]	1603	Digital Inputs	0	3	1	
[Digital Input Status]	1604	Digital Inputs	0	3	1	
[DO0 Parameter ID]	1701	Digital Outputs	0	3020	1	
[DO1 Parameter ID]	1702	Digital Outputs	0	3020	1	
[Digital Output Invert Mask]	1703	Digital Outputs	0	3	1	
[Digital Output Status]	1704	Digital Outputs	0	3	1	
[AI0 Parameter ID]	1801	Analog Inputs	0	3020	1	
[AI0 Signal Lo]	1802	Analog Inputs	0	100	0.01	%
[AI0 Signal Hi]	1803	Analog Inputs	0	100	0.01	%
[AI0 Signal Val]	1804	Analog Inputs	0	100	0.01	%
[AI0 Digital Val]	1805	Analog Inputs	0	4095	1	
[AI1 Parameter ID]	1806	Analog Inputs	0	3020	1	
[AI1 Signal Lo]	1807	Analog Inputs	0	100	0.01	%
[AI1 Signal Hi]	1808	Analog Inputs	0	100	0.01	%
[AI1 Signal Val]	1809	Analog Inputs	0	100	0.01	%
[AI1 Digital Val]	1810	Analog Inputs	0	4095	1	
[AI2 Parameter ID]	1811	Analog Inputs	0	3020	1	
[AI2 Signal Lo]	1812	Analog Inputs	0	100	0.01	%
[AI2 Signal Hi]	1813	Analog Inputs	0	100	0.01	%
[AI2 Signal Val]	1814	Analog Inputs	0	100	0.01	%
[AI2 Digital Val]	1815	Analog Inputs	0	4095	1	
[AO0 Parameter ID]	1901	Analog Outputs	0	3020	1	
[AO0 Signal Lo]	1902	Analog Outputs	0	100	0.01	%
[AO0 Signal Hi]	1903	Analog Outputs	0	100	0.01	%
[AO0 Signal Val]	1904	Analog Outputs	0	100	0.01	%

Appendix B: BIGI-250 Parameter List

[AO0 Digital Val]	1905	Analog Outputs	0	4095	1	
[Master Alarm]	2001	Alarms	0	1	1	
[Alarm Status]	2002	Alarms	-32768	32767	1	
[Master Alarm Mask]	2003	Alarms	0	255	1	
[Battery Under Voltage Alarm Threshold]	2004	Alarms	0	3200	0.1	V
[Battery Under Temperature Alarm Threshold]	2005	Alarms	-273	175	0.01	C
[Temperature Alarm Threshold]	2006	Alarms	-320	320	0.01	C
[User Alarm Parameter ID]	2007	Alarms	0	3020	1	
[User Alarm Threshold]	2008	Alarms	0	100	0.01	%
[User Alarm Greater/Less]	2009	Alarms	0	1	1	
[User Alarm]	2010	Alarms	0	1	1	
[Auto Restart Attempts]	2101	Auto-restart	0	20	1	
[Auto Restart Delay]	2102	Auto-restart	5	300	0.01	sec
[Auto Restart Counter]	2103	Auto-restart	0	255	1	
[Auto Restart Enable Mask 0]	2104	Auto-restart	0	255	1	
[Auto Restart Enable Mask 1]	2105	Auto-restart	-32768	32767	1	
[Auto Restart Enable Mask 2]	2106	Auto-restart	0	31	1	
[System Tripped]	2201	System Faults	0	1	1	
[External Trip]	2202	System Faults	0	1	1	
[Signal Loss Enable]	2203	System Faults	0	15	1	
[LCD Connected Trip Enable]	2204	System Faults	0	1	1	
[User Trip Parameter ID]	2205	System Faults	0	3020	1	
[User Trip Threshold]	2206	System Faults	0	100	0.01	%
[User Trip Greater/Less]	2207	System Faults	0	1	1	
[User Trip Enable]	2208	System Faults	0	1	1	
[Ground Fault Enable]	2209	System Faults	0	1	1	
[Inverter Overload Threshold %]	2210	System Faults	0	150	0.01	%
[Temperature Analog Lo]	2211	System Faults	-273	175	0.01	C
[Temperature Analog Hi]	2212	System Faults	-273	175	0.01	C
[Bat Heatsink Temperature]	2213	System Faults	-273	175	0.01	C
[Bat Heatsink Temp Fault Threshold]	2214	System Faults	-273	175	0.01	C
[Bat Heatsink Temp Fault Time]	2215	System Faults	0	320	0.01	sec
[Bat Heatsink Temp Failure Threshold]	2216	System Faults	-273	175	0.01	C
[Bat Heatsink Temp Failure Time]	2217	System Faults	0	320	0.01	sec
[Grid Heatsink Temperature]	2218	System Faults	-273	175	0.01	C
[Grid Heatsink Temp Fault Threshold]	2219	System Faults	-273	175	0.01	C
[Grid Heatsink Temp Fault Time]	2220	System Faults	0	320	0.01	sec

[Grid Heatsink Temp Failure Threshold]	2221	System Faults	-273	175	0.01	C
[Grid Heatsink Temp Failure Time]	2222	System Faults	0	320	0.01	sec
[Ambient Temperature]	2223	System Faults	-273	175	0.01	C
[Ambient Temp Fault Threshold]	2224	System Faults	-273	175	0.01	C
[Ambient Temp Fault Time]	2225	System Faults	0	320	0.01	sec
[Ambient Temp Failure Threshold]	2226	System Faults	-273	175	0.01	C
[Ambient Temp Failure Time]	2227	System Faults	0	320	0.01	sec
[PV Heatsink Temperature]	2228	System Faults	-273	175	0.01	C
[PV Heatsink Temp Fault Threshold]	2229	System Faults	-273	175	0.01	C
[PV Heatsink Temp Fault Time]	2230	System Faults	0	320	0.01	sec
[PV Heatsink Temp Failure Threshold]	2231	System Faults	-273	175	0.01	C
[PV Heatsink Temp Failure Time]	2232	System Faults	0	320	0.01	sec
[Central Cap Over Voltage Threshold]	2233	System Faults	0	1100	0.1	V
[Central Cap Over Voltage Clear Time]	2234	System Faults	0	3200	0.1	sec
[DC Port Over Voltage Threshold]	2235	System Faults	0	1100	0.1	V
[DC Port Over Current Threshold]	2236	System Faults	0	3200	0.1	Amps
[AC Caps Over Voltage Threshold]	2237	System Faults	0	1100	0.1	V
[AC Port Over Current Threshold]	2238	System Faults	0	3200	0.1	Amps
[Grid Over Voltage Inst Threshold]	2239	System Faults	0	1100	0.1	V
[DC Port Reverse Voltage Threshold]	2240	System Faults	-3200	100	0.1	V
[DC Port Reverse Voltage Clear Threshold]	2241	System Faults	-3200	100	0.1	V
[Central Cap Under Voltage Trip Threshold]	2242	System Faults	0	1100	0.1	V
[Central Cap Under Voltage Trip Time]	2243	System Faults	0	320	0.01	sec
[Central Cap Under Voltage Inst Threshold]	2244	System Faults	0	1100	0.1	V
[Grid Contactor Overload Trip Enable]	2245	System Faults	0	1	1	
[Grid Contactor Overload Current]	2246	System Faults	0	3200	0.1	Amps
[Grid Contactor Overload Time]	2247	System Faults	0	320	0.01	sec
[Fan VSD Failure Time]	2248	System Faults	0	3200	0.1	sec
[Ethernet Comm Loss Enable]	2249	System Faults	0	1	1	
[Ethernet Comm Timeout]	2250	System Faults	0	32000	1	sec
[Ethernet Rx Counter]	2251	System Faults	0	32767	1	

Appendix B: BIGI-250 Parameter List

[Fan VSD Run Command]	2252	System Faults	0	1	1	
[Communication Watchdog Enable]	2253	System Faults	0	1	1	
[Communication Watchdog]	2254	System Faults	-32768	32767	1	
[Communication Watchdog Timeout]	2255	System Faults	0.1	3200	0.1	sec
[PV Over Voltage Fault Threshold]	2301	PV Control Faults	0	3200	0.1	V
[PV Over Voltage Clear Threshold]	2302	PV Control Faults	0	3200	0.1	V
[PV Over Voltage Clear Time]	2303	PV Control Faults	0	3200	0.1	sec
[PV Under Voltage Fault Threshold]	2304	PV Control Faults	0	3200	0.1	V
[PV Under Voltage Clear Threshold]	2305	PV Control Faults	0	3200	0.1	V
[PV Under Voltage Clear Time]	2306	PV Control Faults	0	3200	0.1	sec
[PV Precharge Timeout Threshold]	2307	PV Control Faults	0	3200	0.1	sec
[PV Backfeed Fault Threshold]	2308	PV Control Faults	0	3200	0.1	Amps
[PV Backfeed Fault Time]	2309	PV Control Faults	0	3200	0.1	sec
[PV Backfeed Clear Threshold]	2310	PV Control Faults	0	3200	0.1	Amps
[PV Backfeed Clear Time]	2311	PV Control Faults	0	3200	0.1	sec
[Battery Over Voltage Fault Margin]	2401	Battery Control Faults	0	3200	0.1	V
[Battery Over Voltage Clear Margin]	2402	Battery Control Faults	0	3200	0.1	V
[Battery Over Voltage Clear Time]	2403	Battery Control Faults	0	3200	0.1	sec
[Battery Under Voltage Fault Margin]	2404	Battery Control Faults	0	3200	0.1	V
[Battery Under Voltage Clear Margin]	2405	Battery Control Faults	0	3200	0.1	V
[Battery Under Voltage Clear Time]	2406	Battery Control Faults	0	3200	0.1	sec
[Battery Over Temperature Fault Threshold]	2407	Battery Control Faults	-273	175	0.01	C

[Battery Over Temperature Fault Time]	2408	Battery Control Faults	0.01	10	0.01	sec
[Battery Over Temperature Clear Threshold]	2409	Battery Control Faults	-273	175	0.01	C
[Battery Over Temperature Clear Time]	2410	Battery Control Faults	0.01	10	0.01	sec
[Battery Under Temperature Fault Threshold]	2411	Battery Control Faults	-273	175	0.01	C
[Battery Under Temperature Fault Time]	2412	Battery Control Faults	0.01	10	0.01	sec
[Battery Under Temperature Clear Threshold]	2413	Battery Control Faults	-273	175	0.01	C
[Battery Under Temperature Clear Time]	2414	Battery Control Faults	0.01	10	0.01	sec
[Battery Overcharge Fault Enable]	2415	Battery Control Faults	0	1	1	
[Battery Total Charge Capacity]	2416	Battery Control Faults	0	32000	1	Amp-hours
[Battery Overcharge Threshold%]	2417	Battery Control Faults	0	320	0.01	
[Battery Precharge Timeout Threshold]	2418	Battery Control Faults	0	100	0.1	sec
[Battery Over Charge Current Fault Thresh]	2419	Battery Control Faults	-3200	3200	0.1	Amps
[Battery Over Charge Current Fault Time]	2420	Battery Control Faults	0.1	3200	0.1	sec
[Battery Current Sensor Failure Thresh]	2421	Battery Control Faults	0	3200	0.1	Amps
[Battery Current Sensor Failure Time]	2422	Battery Control Faults	0.1	3200	0.1	sec
[PV Battery Short Fault Threshold]	2423	Battery Control Faults	0	3200	0.1	Amps
[PV Battery Short Fault Time]	2424	Battery Control Faults	0.1	3200	0.1	sec
[Vgrid Synch Trip Threshold]	2501	Grid Control Faults	-32	32	0.001	rads
[Vgrid Synch Trip Inst Threshold]	2502	Grid Control Faults	-32	32	0.001	rads
[Vgrid Synch Trip Clear Threshold]	2503	Grid Control Faults	-32	32	0.001	rads
[Vgrid Synch Trip Time]	2504	Grid Control Faults	0	3.2	0.0001	sec

Appendix B: BIGI-250 Parameter List

[Vgrid Synch Clear Time]	2505	Grid Control Faults	0	3.2	0.0001	sec
[Vgrid Remote Synch Trip Threshold]	2506	Grid Control Faults	-32	32	0.001	rads
[Vgrid Remote Synch Trip Inst Threshold]	2507	Grid Control Faults	-32	32	0.001	rads
[Vgrid Remote Synch Trip Clear Threshold]	2508	Grid Control Faults	-32	32	0.001	rads
[Vgrid Remote Synch Trip Time]	2509	Grid Control Faults	0	3.2	0.0001	sec
[Vgrid Remote Synch Clear Time]	2510	Grid Control Faults	0	3.2	0.0001	sec
[Grid Over Voltage Fault Threshold]	2511	Grid Control Faults	0	1000	0.1	V
[Grid Over Voltage Fault Time]	2512	Grid Control Faults	0	320	0.01	sec
[Grid Over Voltage Clear Threshold]	2513	Grid Control Faults	0	1000	0.1	V
[Grid Over Voltage Clear Time]	2514	Grid Control Faults	0	320	0.01	sec
[Grid Module Startup Timeout]	2515	Grid Control Faults	0	320	0.01	sec
[Backup Synch Trip Threshold]	2601	Backup Control Faults	-32	32	0.001	rads
[Backup Synch Trip Inst Threshold]	2602	Backup Control Faults	-32	32	0.001	rads
[Backup Synch Trip Clear Threshold]	2603	Backup Control Faults	-32	32	0.001	rads
[Backup Synch Trip Time]	2604	Backup Control Faults	0	3.2	0.0001	sec
[Backup Synch Clear Time]	2605	Backup Control Faults	0	3.2	0.0001	sec
[Motor Synch Trip Threshold]	2701	Motor Control Faults	-32	32	0.001	rads
[Motor Synch Trip Inst Threshold]	2702	Motor Control Faults	-32	32	0.001	rads
[Motor Synch Trip Clear Threshold]	2703	Motor Control Faults	-32	32	0.001	rads
[Motor Synch Trip Time]	2704	Motor Control Faults	0	3.2	0.0001	sec
[Motor Synch Clear Time]	2705	Motor Control Faults	0	3.2	0.0001	sec

Appendix B: BIGI-250 Parameter List

[Fault Buffer 0 - Fault ID]	2801	Fault Buffer	-32768	32767	1	
[Fault Buffer 0 - Fault Time]	2802	Fault Buffer	0	2359	1	hhmm
[Fault Buffer 0 - Fault Date]	2803	Fault Buffer	0	1231	1	MMD D
[Fault Buffer 0 - Battery Voltage]	2804	Fault Buffer	-3276.8	3276.7	0.1	V
[Fault Buffer 0 - Battery Current Inst]	2805	Fault Buffer	-3276.8	3276.7	0.1	Amps
[Fault Buffer 0 - Battery Current Avg]	2806	Fault Buffer	-3276.8	3276.7	0.1	Amps
[Fault Buffer 0 - PV Voltage]	2807	Fault Buffer	-3276.8	3276.7	0.1	V
[Fault Buffer 0 - PV Current Inst]	2808	Fault Buffer	-3276.8	3276.7	0.1	Amps
[Fault Buffer 0 - PV Current Avg]	2809	Fault Buffer	-3276.8	3276.7	0.1	Amps
[Fault Buffer 0 - AC Voltage]	2810	Fault Buffer	-3276.8	3276.7	0.1	V
[Fault Buffer 0 - AC Current Inst]	2811	Fault Buffer	-3276.8	3276.7	0.1	Amps
[Fault Buffer 0 - AC Current Avg]	2812	Fault Buffer	-3276.8	3276.7	0.1	Amps
[Fault Buffer 0 - Central Cap Voltage]	2813	Fault Buffer	-3276.8	3276.7	0.1	V
[Fault Buffer 0 - Status Register 1]	2814	Fault Buffer	-32768	32767	1	
[Fault Buffer 0 - Status Register 2]	2815	Fault Buffer	-32768	32767	1	
[Fault Buffer 0 - Alarm Status Register]	2816	Fault Buffer	-32768	32767	1	
[Fault Buffer 1 - Fault ID]	2817	Fault Buffer	-32768	32767	1	
[Fault Buffer 1 - Fault Time]	2818	Fault Buffer	0	2359	1	hhmm
[Fault Buffer 1 - Fault Date]	2819	Fault Buffer	0	1231	1	MMD D
[Fault Buffer 1 - Battery Voltage]	2820	Fault Buffer	-3276.8	3276.7	0.1	V
[Fault Buffer 1 - Battery Current Inst]	2821	Fault Buffer	-3276.8	3276.7	0.1	Amps
[Fault Buffer 1 - Battery Current Avg]	2822	Fault Buffer	-3276.8	3276.7	0.1	Amps
[Fault Buffer 1 - PV Voltage]	2823	Fault Buffer	-3276.8	3276.7	0.1	V
[Fault Buffer 1 - PV Current Inst]	2824	Fault Buffer	-3276.8	3276.7	0.1	Amps
[Fault Buffer 1 - PV Current Avg]	2825	Fault Buffer	-3276.8	3276.7	0.1	Amps
[Fault Buffer 1 - AC Voltage]	2826	Fault Buffer	-3276.8	3276.7	0.1	V
[Fault Buffer 1 - AC Current Inst]	2827	Fault Buffer	-3276.8	3276.7	0.1	Amps
[Fault Buffer 1 - AC Current Avg]	2828	Fault Buffer	-3276.8	3276.7	0.1	Amps
[Fault Buffer 1 - Central Cap Voltage]	2829	Fault Buffer	-3276.8	3276.7	0.1	V
[Fault Buffer 1 - Status Register 1]	2830	Fault Buffer	-32768	32767	1	
[Fault Buffer 1 - Status Register 2]	2831	Fault Buffer	-32768	32767	1	
[Fault Buffer 1 - Alarm Status Register]	2832	Fault Buffer	-32768	32767	1	

Appendix B: BIGI-250 Parameter List

[Fault Buffer 2 - Fault ID]	2833	Fault Buffer	-32768	32767	1	
[Fault Buffer 2 - Fault Time]	2834	Fault Buffer	0	2359	1	hhmm
[Fault Buffer 2 - Fault Date]	2835	Fault Buffer	0	1231	1	MMD D
[Fault Buffer 2 - Battery Voltage]	2836	Fault Buffer	-3276.8	3276.7	0.1	V
[Fault Buffer 2 - Battery Current Inst]	2837	Fault Buffer	-3276.8	3276.7	0.1	Amps
[Fault Buffer 2 - Battery Current Avg]	2838	Fault Buffer	-3276.8	3276.7	0.1	Amps
[Fault Buffer 2 - PV Voltage]	2839	Fault Buffer	-3276.8	3276.7	0.1	V
[Fault Buffer 2 - PV Current Inst]	2840	Fault Buffer	-3276.8	3276.7	0.1	Amps
[Fault Buffer 2 - PV Current Avg]	2841	Fault Buffer	-3276.8	3276.7	0.1	Amps
[Fault Buffer 2 - AC Voltage]	2842	Fault Buffer	-3276.8	3276.7	0.1	V
[Fault Buffer 2 - AC Current Inst]	2843	Fault Buffer	-3276.8	3276.7	0.1	Amps
[Fault Buffer 2 - AC Current Avg]	2844	Fault Buffer	-3276.8	3276.7	0.1	Amps
[Fault Buffer 2 - Central Cap Voltage]	2845	Fault Buffer	-3276.8	3276.7	0.1	V
[Fault Buffer 2 - Status Register 1]	2846	Fault Buffer	-32768	32767	1	
[Fault Buffer 2 - Status Register 2]	2847	Fault Buffer	-32768	32767	1	
[Fault Buffer 2 - Alarm Status Register]	2848	Fault Buffer	-32768	32767	1	
[Fault Buffer 3 - Fault ID]	2849	Fault Buffer	-32768	32767	1	
[Fault Buffer 3 - Fault Time]	2850	Fault Buffer	0	2359	1	hhmm
[Fault Buffer 3 - Fault Date]	2851	Fault Buffer	0	1231	1	MMD D
[Fault Buffer 3 - Battery Voltage]	2852	Fault Buffer	-3276.8	3276.7	0.1	V
[Fault Buffer 3 - Battery Current Inst]	2853	Fault Buffer	-3276.8	3276.7	0.1	Amps
[Fault Buffer 3 - Battery Current Avg]	2854	Fault Buffer	-3276.8	3276.7	0.1	Amps
[Fault Buffer 3 - PV Voltage]	2855	Fault Buffer	-3276.8	3276.7	0.1	V
[Fault Buffer 3 - PV Current Inst]	2856	Fault Buffer	-3276.8	3276.7	0.1	Amps
[Fault Buffer 3 - PV Current Avg]	2857	Fault Buffer	-3276.8	3276.7	0.1	Amps
[Fault Buffer 3 - AC Voltage]	2858	Fault Buffer	-3276.8	3276.7	0.1	V
[Fault Buffer 3 - AC Current Inst]	2859	Fault Buffer	-3276.8	3276.7	0.1	Amps
[Fault Buffer 3 - AC Current Avg]	2860	Fault Buffer	-3276.8	3276.7	0.1	Amps
[Fault Buffer 3 - Central Cap Voltage]	2861	Fault Buffer	-3276.8	3276.7	0.1	V
[Fault Buffer 3 - Status Register 1]	2862	Fault Buffer	-32768	32767	1	
[Fault Buffer 3 - Status Register 2]	2863	Fault Buffer	-32768	32767	1	
[Fault Buffer 3 - Alarm Status Register]	2864	Fault Buffer	-32768	32767	1	

[Battery Vcc Control P-gain]	2901	Low Level Parameters	0	32.767	0.001	
[Battery Vcc Control I-gain]	2902	Low Level Parameters	0	32.767	0.001	
[PV Precharge Vcc Control P-gain]	2903	Low Level Parameters	0	32.767	0.001	
[PV Precharge Vcc Control I-gain]	2904	Low Level Parameters	0	32.767	0.001	
[PV Vcc Control P-gain]	2905	Low Level Parameters	0	32.767	0.001	
[Vcc Target On-grid]	2906	Low Level Parameters	100	1000	0.1	V
[Vcc Target Off-grid]	2907	Low Level Parameters	100	1000	0.1	V
[Vcc Power Margin]	2908	Low Level Parameters	0	3200	0.1	kW
[Vcc Voltage Margin]	2909	Low Level Parameters	0	200	0.1	V
[Battery Power Limit Min]	2910	Low Level Parameters	-3200	3200	0.1	kW
[Battery Power Limit Max]	2911	Low Level Parameters	-3200	3200	0.1	kW
[Battery Current Limit Min]	2912	Low Level Parameters	-3200	3200	0.1	Amps
[Battery Current Limit Max]	2913	Low Level Parameters	-3200	3200	0.1	Amps
[PV Power Limit Min]	2914	Low Level Parameters	-3200	3200	0.1	kW
[PV Power Limit Max]	2915	Low Level Parameters	-3200	3200	0.1	kW
[PV Current Limit Min]	2916	Low Level Parameters	-3200	3200	0.1	Amps
[PV Current Limit Max]	2917	Low Level Parameters	-3200	3200	0.1	Amps
[AC Apparent Power Limit Max]	2918	Low Level Parameters	-3200	3200	0.1	kVA
[AC Real Power Limit Min]	2919	Low Level Parameters	-3200	3200	0.1	kW
[AC Real Power Limit Max]	2920	Low Level Parameters	-3200	3200	0.1	kW
[AC Reactive Power Limit Min]	2921	Low Level Parameters	-3200	3200	0.1	kW

Appendix B: BIGI-250 Parameter List

[AC Reactive Power Limit Max]	2922	Low Level Parameters	-3200	3200	0.1	kW
[AC Current Limit Max]	2923	Low Level Parameters	-3200	3200	0.1	Amps
[Precharge Current Limit]	2924	Low Level Parameters	-3200	3200	0.1	Amps
[Battery Target Power Min]	2925	Low Level Parameters	-3200	3200	0.1	kW
[Battery Target Power Max]	2926	Low Level Parameters	-3200	3200	0.1	kW
[Battery Target Current Min]	2927	Low Level Parameters	-3200	3200	0.1	Amps
[Battery Target Current Max]	2928	Low Level Parameters	-3200	3200	0.1	Amps
[Fan Speed]	2929	Low Level Parameters	0	100	0.01	%
[Max Heatsink Temperature Difference]	2930	Low Level Parameters	0	320	0.01	C
[Fan Control Temperature Adjustment]	2931	Low Level Parameters	0	320	0.01	C
[Fan Min Speed Temp]	2932	Low Level Parameters	0	320	0.01	C
[Fan Max Speed Temp]	2933	Low Level Parameters	0	320	0.01	C
[Fan Turn Off Delay]	2934	Low Level Parameters	0	32000	1	sec
[Grid Contactor Current Limit]	2935	Low Level Parameters	0	3200	0.1	Amps
[Grid Contactor Current Limit I-gain]	2936	Low Level Parameters	0	320	0.01	
[Power Command Slew Rate]	2937	Low Level Parameters	0.1	3200	0.1	W/P
[Reactive Power Command Slew Rate]	2938	Low Level Parameters	0.1	3200	0.1	W/P
[Power Control P-gain]	2939	Low Level Parameters	0	32.767	0.001	
[Power Control I-gain]	2940	Low Level Parameters	0	32.767	0.001	
[Virtual Generator Inertia]	2941	Low Level Parameters	0	32.767	0.001	
[Virtual Generator Damping Freq Gain]	2942	Low Level Parameters	0	3200	0.1	

Appendix B: BIGI-250 Parameter List

[Virtual Generator Damping dfdt Gain]	2943	Low Level Parameters	0	320	0.01	
[Virtual Generator Droop Freq1]	2944	Low Level Parameters	-60	60	0.01	Hz
[Virtual Generator Droop Freq2]	2945	Low Level Parameters	-60	60	0.01	Hz
[Virtual Generator Droop P1]	2946	Low Level Parameters	-3200	3200	0.1	kW
[Virtual Generator Droop P2]	2947	Low Level Parameters	-3200	3200	0.1	kW
[Virtual Generator Power Min Offset]	2948	Low Level Parameters	-3200	3200	0.1	kW
[Virtual Generator Power Max Offset]	2949	Low Level Parameters	-3200	3200	0.1	kW
[Battery Current Limit P-gain]	2950	Low Level Parameters	0	327.67	0.01	
[Battery Current Limit I-gain]	2951	Low Level Parameters	0	32.67	0.001	
[Battery Current Adjustment Min]	2952	Low Level Parameters	-1000	1000	0.1	Amps
[Battery Current Adjustment Max]	2953	Low Level Parameters	-1000	1000	0.1	Amps
[Battery Voltage Limit P-gain]	2954	Low Level Parameters	0	327.67	0.01	
[Battery Voltage Limit I-gain]	2955	Low Level Parameters	0	0.3277	0.00001	
[Battery Power Limit Lo Shift]	2956	Low Level Parameters	-32	32	0.001	kW
[Battery Power Limit Lo Scale]	2957	Low Level Parameters	-3.2	3.2	0.0001	
[Battery Power Limit Hi Shift]	2958	Low Level Parameters	-32	32	0.001	kW
[Battery Power Limit Hi Scale]	2959	Low Level Parameters	-3.2	3.2	0.0001	
[Iq Control P-gain]	2960	Low Level Parameters	0	3.2	0.0001	
[Iq Control I-gain]	2961	Low Level Parameters	0	0.032	0.000001	
[Vpwm Min]	2962	Low Level Parameters	0	1000	0.1	V
[Grid Rsim]	2963	Low Level Parameters	0	32	0.001	Ohm

Appendix B: BIGI-250 Parameter List

[Phase Angle Vcc Gain On-grid]	2964	Low Level Parameters	0	0.32	0.00001	
[Phase Angle Vcc Gain Off-grid]	2965	Low Level Parameters	0	0.32	0.00001	
[Phase Angle Power Gain On-grid]	2966	Low Level Parameters	0	0.32	0.00001	
[Phase Angle Power Gain Off-grid]	2967	Low Level Parameters	0	0.32	0.00001	
[Battery Voltage Limit Max Current]	2968	Low Level Parameters	-1000	1000	0.1	Amps
[Transformer Series Resistance]	2969	Low Level Parameters	0	32.767	0.001	Ohm
[Transformer Series Inductance]	2970	Low Level Parameters	0	32.767	0.001	mH
[Transformer Magnetizing Inductance]	2971	Low Level Parameters	0	32.767	0.001	H
[AC Port Startup Delay]	2972	Low Level Parameters	0	320	0.01	sec
[Startup Phase I-gain]	2973	Low Level Parameters	0	320	0.01	
[Switching Frequency]	2974	Low Level Parameters	500	10000	1	Hz
[Total DC Power Limit Max]	2975	Low Level Parameters	0	3200	0.1	kW
[Phase 2 Voltage Adj]	2976	Low Level Parameters	-327.68	327.67	0.01	V
[Phase 3 Voltage Adj]	2977	Low Level Parameters	-327.68	327.67	0.01	V
[Phase 2 Angle Adj]	2978	Low Level Parameters	-327.68	327.67	0.01	deg
[Phase 3 Angle Adj]	2979	Low Level Parameters	-327.68	327.67	0.01	deg
[Test Command]	3001	Testing	0	32767	1	
[Test Val]	3002	Testing	0	327.67	0.01	
[Logic Analyzer Output Select 0]	3003	Testing	-32768	32767	1	
[Logic Analyzer Output Select 1]	3004	Testing	-32768	32767	1	
[Logic Analyzer Output Select 2]	3005	Testing	-32768	32767	1	
[Logic Analyzer Output Select 3]	3006	Testing	-32768	32767	1	
[Logic Analyzer Output Select 4]	3007	Testing	-32768	32767	1	
[Logic Analyzer Output Select 5]	3008	Testing	-32768	32767	1	
[Logic Analyzer Output Select 6]	3009	Testing	-32768	32767	1	
[Logic Analyzer Output Select 7]	3010	Testing	-32768	32767	1	

[Test Parameter 0]	3011	Testing	-327.68	327.67	0.01	
[Test Parameter 1]	3012	Testing	-327.68	327.67	0.01	
[Test Parameter 2]	3013	Testing	-327.68	327.67	0.01	
[Test Parameter 3]	3014	Testing	-327.68	327.67	0.01	
[Test Parameter 4]	3015	Testing	-327.68	327.67	0.01	
[Test Parameter 5]	3016	Testing	-327.68	327.67	0.01	
[Test Parameter 6]	3017	Testing	-327.68	327.67	0.01	
[Test Parameter 7]	3018	Testing	-327.68	327.67	0.01	
[Test Parameter 8]	3019	Testing	-327.68	327.67	0.01	
[Test Parameter 9]	3020	Testing	-327.68	327.67	0.01	

Table 0-1: BIGI-250 Parameter List

This page intentionally left blank.

C BIGI 250 Default Grid Trip Settings

Appendix C: BIGI 250 Default Trip Settings

Trip Setting Description	Parameter	Default Setting	Notes
Under frequency trip (fast) threshold	[AI Minimum Frequency]	57 Hz	Not user-settable
Over frequency trip (fast) threshold	[AI Maximum Frequency]	60.5 Hz	Not user-settable
Over/under frequency trip (fast) time	[AI Outer Frequency Window Time]	0.16 sec	Not user-settable
Under frequency trip (slow) threshold	[AI Sag Frequency]	59.3 Hz	User-settable
Under frequency trip (slow) time	[AI Frequency Sag Time]	0.16 sec	User-settable
Under voltage trip (fast) threshold	[AI Minimum Voltage]	50 %	Not user-settable
Over voltage trip (fast) threshold	[AI Maximum Voltage]	120 %	Not user-settable
Over/under voltage trip (fast) time	[AI Outer Voltage Window Time]	0.16 sec	Not user-settable
Under voltage trip (slow) threshold	[AI Sag Voltage]	88 %	User-settable
Over voltage trip (slow) threshold	[AI Surge Voltage]	110 %	User-settable
Under voltage trip (slow) time	[AI Voltage Sag Time]	1.9 sec	Not user-settable
Over voltage trip (slow) time	[AI Voltage Surge Time]	0.9 sec	Not user-settable

D Return Material Authorization

D.1 Return Material Authorization Policy

Before returning a product directly to PPS, you must obtain a Return Material Authorization (RMA) number and the correct factory "Ship To" address. Products must also be shipped prepaid. Product shipments will be refused and returned at your expense if they are unauthorized, returned without an RMA number clearly marked on the outside of the shipping box, if they are shipped collect, or if they are shipped to the wrong location.

When you contact PPS to obtain service, please have your instruction manual ready for reference and be prepared to supply:

- The serial number of your product
- Information about the installation and use of the unit
- Information about the failure and/or reason for the return
- A copy of your dated proof of purchase

Record these details on page 116.

D.2 Out of Warranty Service

For information regarding out of warranty service, contact a PPS Customer Service Representative.

D.3 Contact Information

Corporate Headquarters

Princeton Power Systems
3490 Route 1 North
Building #17
Princeton, NJ 08540
USA

Tel. +1 609.955.5390
Fax. +1 609.751.9225
Email. info@princetonpower.com

Technical Support

Email. support@princetonpower.com
Tel. +1 609.955.5390

Sales

Email. sales@princetonpower.com
Tel. +1 609.955.5390

www.princetonpower.com

D.4 Information About This System

Record the following information and be sure to keep your proof of purchase.

- Serial Number _____
- Purchased From _____

Date of Purchase _____

If you need to contact Customer Service, please record the following details before calling. This information will help our representatives give you better service.

Type of installation (e.g. PVwith storage, EV Charging, Microgrid) _____

Length of time inverter has been installed _____

Battery/battery bank size _____

Battery type (e.g. PbA, LiPh, PbC, other) _____

DC wiring size and length _____

Alarm sounding? _____

Description of indicators on front panel _____

Appliances operating when problem occurred _____

Description of problem _____

This page intentionally left blank.