



PLATINUM

USER MANUAL

RANGEHOOD SERIES

AUPL-SC90/60SS, AUPL-GC90SS, AUPL-TC90SS

IMPORTANT // Please ensure that you read through this user manual prior to installation and use. This manual contains important information to ensure optimal performance and keep you safe. Please retain your proof of purchase, as this will be required in the event that you require warranty service. Remember to retain this manual for future reference.

| platinumappliances.com.au

HELLO

CONGRATULATIONS ON THE SELECTION OF THIS PLATINUM APPLIANCE.

Please read through this user manual carefully as it contains information that will ensure that your appliance is installed correctly, important operating & care instructions and also some advice of what you need to do if this appliance is not performing as intended.

CONTENTS

HELLO	2
CONTENTS	3
WARNING & SAFETY INFORMATION	4
PRODUCT OVERVIEW	5
ELECTRICAL CONNECTION	6
INSTALLATION	7-8
OPERATING INSTRUCTIONS	9
MAINTAINING YOUR RANGEHOOD	10
PRODUCT SPECIFICATIONS	11
PROOF OF PURCHASE	12
WARRANTY TERMS & CONDITIONS	13
NOTES	14-15
CONTACT DETAILS	16

WARNING & SAFETY INFORMATION

This appliance is intended for indoor domestic use only. It is not suitable for outdoor kitchens.

This appliance complies with all of the relevant local and national standards. Inappropriate use can lead to personal injury and cause damage to property.

To avoid risk of injury or damage please read these instructions carefully before installing and operating this appliance.

It is important to keep these instructions in a safe place for future reference and to ensure that all users are familiar with the operations and safety precautions with this appliance.

This appliance is not intended for use by persons (including children) with reduced physical, sensory, or mental capabilities, or a lack of experience and knowledge, unless they have been given supervision or instruction concerning use of the appliance by a person responsible for their safety.

Young children should be supervised to ensure that they do not play with the appliance .

Please be aware on the cooker hood the halogen lamps may get very hot during use and the may retain their heat for some time after the unit is switched off.

There should be adequate ventilation of the room when the rangehood is used at the same time as appliances burning gas or other fuels.

IMPORTANT // Read the information provided about cleaning of your appliance, methods and frequency.

There is a fire risk if the cleaning procedures are not adhered to.

Do not flambé under the rangehood.

Exhaust air must not be discharged into an existing flue which is used for exhausting fumes from the appliance burning gas or other fuels.

The minimum distance between the hob surface and the lowest part of the rangehood is 600mm. This distance shall be at least 650mm, if the rangehood is installed over a gas hob. If the instructions for the hob specify a greater distance this must taken into account.

Due attention should be given to ensure that any applicable regulations concerning the discharge of the exhaust are adhered to.

If the supply cord of this appliance is damaged, it must only be replaced by the manufacturer or it's service agent or a similarly qualified person in order to avoid a hazard.

PRODUCT OVERVIEW

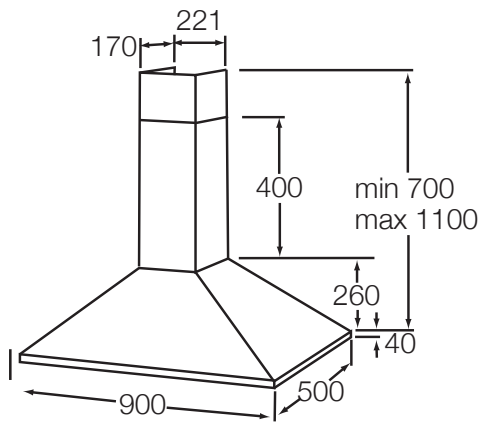

STANDARD CANOPY

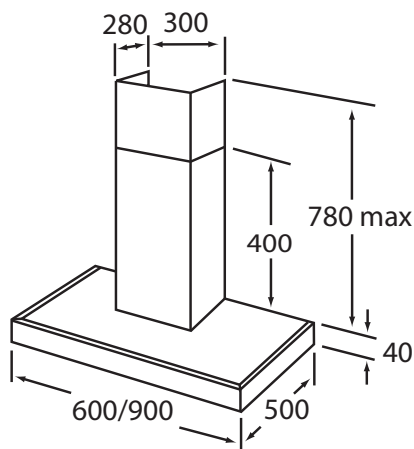

T-CANOPY

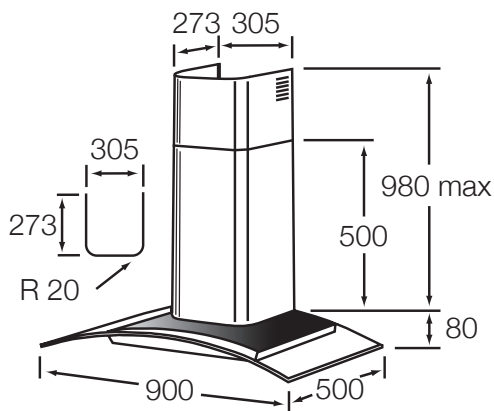

GLASS CANOPY

PUSH BUTTON CONTROLS

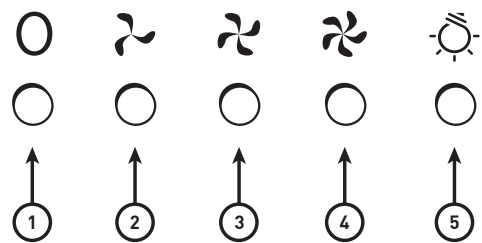

1. on/off
2. speed 1
3. speed 2
4. speed 3
5. light

ELECTRONIC CONTROLS

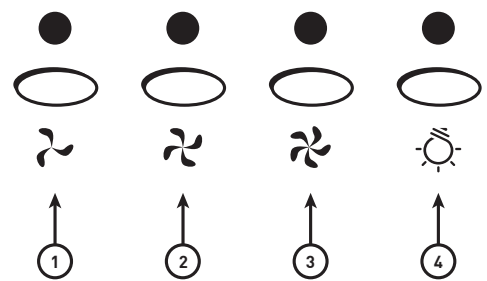

1. speed 1
2. speed 2
3. speed 3
4. light

ELECTRICAL CONNECTION

NOTICE // This appliance must be connected only by a licensed electrician and installed in accordance with the manufacturers instructions.

- Installation, repairs and other work by unqualified persons could be dangerous, for which the manufacturer cannot be held liable.
- Ensure power is not supplied to the appliance until after installation or repair work has been carried out.
- Do not connect the appliance to the mains electricity supply by an extension lead. These do not guarantee the required safety of the appliance.
- The connection data is given on the data plate. This is visible when the grease filters have been removed. Ensure that this data matches the household mains supply.
- Connection of this appliance should be made via a suitable isolator or a double pole fused spur connection unit which complies with national and local safety regulations and the On-Off switch should be easily accessible after the appliance has been built in.
- When switched off there must be an all-pole contact gap of 3 mm in the switch (including switch, fuses and relays according to EN 60335).
- If the switch is not accessible after installation (depending on country), an additional means of disconnection must be provided for all poles.
- For extra safety it is advisable to install a suitable residual current device (RCD). Contact a qualified electrician for advice.

IMPORTANT // This appliance is supplied for connection to a 230V~50Hz supply.

The wires in the mains lead are coloured in accordance with the following code:

Green/Yellow = **Earth**

Blue = **Neutral**

Brown = **Live**

WARNING // THIS APPLIANCE MUST BE EARTHED

INSTALLATION

HEIGHT OF WALL CANOPY

The chimney is telescopic and is designed for hood installations between 650 to 750 mm above the cooking surface.

Select the desired installation height of the wall canopy.

Any installation above 750 mm will compromise the extraction performance.

For optimal efficiency, use smooth-wall, solid galvanized or plastic ducting for reduced noise and increased airflow.

Flexible ducting should only be used as a last resort (ie in difficult installations) and if used, ensure that it is pulled tight.

The smoother, straighter and shorter the ducting the quieter and more efficient the wall canopy will perform.

PREPARING THE WALL CANOPY FOR INSTALLATION

Please read all the instructions carefully before installing the wall canopy.

Remove the filters from the canopy to allow access to wall mounting holes.

To remove the filters, pull the relative catch, tilting it downwards until it disengages from the supports. Reverse these instructions when refitting the filters.

Prior to drilling any holes, check that the area behind the surface to be drilled is clear of any electrical cables or pipes etc.

Stainless Steel/Iridium is very easily damaged during installation if abraded or knocked by tools.

Whenever possible, protect the top of the cooktop with cardboard or the like to prevent damage on installation.

INSTALLATION

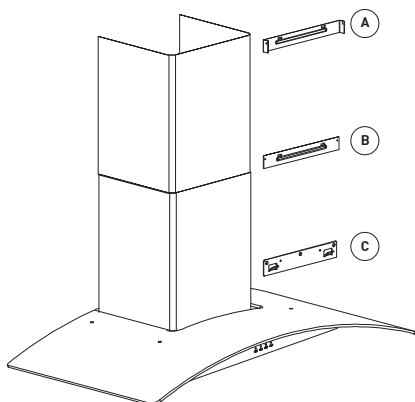

GLASS CANOPIES

1. Mounting to a stud is recommended. However if mounting to other wall types different fasteners will be required.
2. Position the canopy mounting bracket (C) in the required position. Mark and drill the pilot holes. Screw the bracket to the wall, ensuring that the bracket is level as this will determine the final level of the rangehood.
3. Carefully position the rangehood body on the bracket.
4. Position the flue cover mounting brackets (A-B) in the required position. Mark and drill the pilot holes. Screw the brackets to the wall.
5. Attach the ducting to the rangehood and duct according to your requirements (external ducting or recirculating).
6. Install the flue covers and secure the top flue cover to the flue bracket with the provided screws.
7. Carefully place the glass over the body of the rangehood. Fasten the glass to the body with the 4 provided screws.
8. Refit the filters and power the unit.

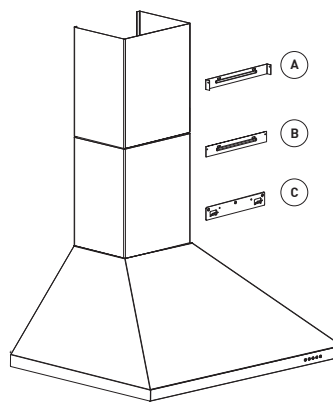

STANDARD AND T-CANOPIES

1. Mounting to a stud is recommended. However if mounting to other wall types different fasteners will be required.
2. Position the canopy mounting bracket (C) in the required position. Mark and drill the pilot holes. Screw the bracket to the wall, ensuring that the bracket is level as this will determine the final level of the rangehood.
3. Carefully position the rangehood body on the bracket.
4. Position the flue cover mounting brackets (A-B) in the required position. Mark and drill the pilot holes. Screw the brackets to the wall.
5. Attach the ducting to the rangehood and duct according to your requirements (external ducting or recirculating).
6. Install the flue covers and secure the top flue cover to the flue bracket with the provided screws.
7. Refit the filters and power the unit.

WARNING // Do not penetrate any screws into the rangehood as this may result in electrical hazards. Failure to install the screws or fixing device in accordance with these instructions may result in electrical hazards.

OPERATING INSTRUCTIONS

ELECTRONIC CONTROLS

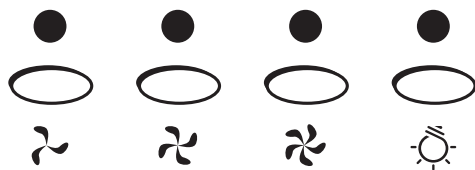

TO TURN THE FAN ON

Press the required speed button once, the fan will turn on and run at the required speed. The light above the button will illuminate to indicate the selected speed.

TO TURN THE FAN OFF

Press the fan speed button beneath the illuminated light. The same button used to turn the fan on, will turn the fan off.

TO USE THE LIGHT

The light can be used by pressing the button above light symbol once. The light is switched off by pressing the same button again.

PUSH BUTTON CONTROLS



TO TURN THE FAN ON

Press the required speed button once, the fan will turn on and run at the required speed. The selected button will remain depressed to indicate that it has been selected.

TO TURN THE FAN OFF

Press the first button, the fan will then stop.

TO USE THE LIGHT

The light can be used by pressing the button above light symbol once. The light is switched off by pressing the same button again.

MAINTAINING YOUR RANGEHOOD

IMPORTANT // Switch off and unplug the rangehood at the powerpoint before undertaking any cleaning or maintenance on the unit.

LIGHT BULB REPLACEMENT

(Halogen bulb 12 Volts/10 Watt)

Switch off the power to the canopy hood and allow the bulb to cool.

Use a small bladed screwdriver to prise off the light cover, taking care not to damage the surrounding material.

Use a cloth to remove the bulb.

Replace with a new bulb using a cloth. Do not touch the bulb with fingers.

Snap the cover back in place.

GENERAL MAINTENANCE

To prevent any surface damage never use any abrasive products or products that contain soda, acids, chlorides or solvents.

To clean the surface of the appliance use a mild detergent in warm water, with a soft non-abrasive cloth.

Only use a damp cloth as use of excessive water can penetrate the unit and cause damage.

Dry surface thoroughly after cleaning with a soft cloth to prevent marking of the surfaces.

FILTER MAINTENANCE

To ensure that the rangehood performs at it's best, filters need to be cleaned at least monthly or more frequently with heavy use

The filters can be cleaned using hot soapy water and a soft nylon brush or placed in a dishwasher.

NOTE // Cleaning the filters in the dishwasher may cause permanent discoloration of the surface. This does not in any way affect the performance of the filters.

Charcoal filters cannot be cleaned or reused. Replace filters every 3-6months dependant on use and cooking style. Please dispose of used filters responsibly.

NOTE // Oversaturated filters are a fire hazard so regular cleaning/replacement is a must.

PRODUCT SPECIFICATIONS

PLATINUM RANGEHOOD SPECIFICATIONS

Voltage	220 - 240V~
Frequency	50Hz
Rated motor input power	190W
Rated input power	230W
Illumination	≤ 20W + 20W
Suction capacity	≤ 700m ³ /h
Plug rating	10A

PROOF OF PURCHASE

ATTACH YOUR PROOF OF PURCHASE
FOR FUTURE REFERENCE

WARRANTY TERMS & CONDITIONS

INTERSOURCE SOLUTIONS PTY LTD (THE "COMPANY")

OUR WARRANTY

PRODUCTS	WARRANTY
Ovens, Cooktops, rangehoods, dishwashers, Mixers	24 months from the original date of purchase
Microwave Ovens	12 months from the original date of purchase

Company warrants the goods to be free from defects occurring in materials and/or workmanship under normal domestic use of the goods when operated in accordance with the supplied instructions for the period stated above.

Under the terms of this warranty, the repair or replacement of product during the above warranty period is at the option of the Company or its authorised service centre. If a replacement product is supplied, warranty remains based on the original date of purchase.

This warranty extends only to:

- defects occurring in materials and/or workmanship under normal domestic use of the goods when operated in accordance with the supplied instructions; and
- goods installed by a qualified person and when provided with a certificate of compliance in accordance with state/territory laws; and
- goods sold by Company or its authorized distributors or dealers and only where the goods are used and services within Australia.

Reasonable evidence of the date of your original purchase must be provided to qualify for this warranty. The original sales receipt is your best proof of purchase.

This warranty does not cover;

- to the extent permissible by law,

- consequential damage or failure due to accident damage, impact, misuse or negligence;
- unauthorised alteration, modification or substitution of any parts of this appliance, installation or use of this appliance not in accordance with the instructions supplied;
- consumable components such as charcoal filters, glass items and light globes;
- malfunction of goods due to faulty installation or operation.
- goods that have their serial number or model number label removed or defaced.

Charges will apply for any non-warranty services performed.

All costs of re-installation, relocation, cartage, freight, mileage expenses and insurance associated with this warranty and service are to be paid by the claimant. For Return to Base services, you must ensure that goods are packed properly in appropriate packing. Any damage due to transport or improper packing will be at your own risk and expense.

Our goods come with guarantees that cannot be excluded under the Australian Consumer Law. You are entitled to a replacement or refund for a major failure and for compensation for any other reasonably foreseeable loss or damage. You are also entitled to have the goods repaired or replaced if the goods fail to be of acceptable quality and the failure does not amount to a major failure.

Notwithstanding the preceding clause, the liability of Company in respect of a breach of a consumer guarantee or any warranty made under these warranty terms and conditions for any goods not of a kind ordinarily acquired for personal, domestic or household use is limited, in relation to the goods to the extent permissible by law and at the option of Company:

- replacing the goods or the supply of equivalent goods;
- the repair of the goods;
- the payment of the cost of replacing the goods or of acquiring equivalent goods; or
- the payment of the cost of having the goods repaired.

To the extent permitted by law, all other warranties whether implied or otherwise, not set out in these warranty terms and conditions are excluded and Company is not liable in contract, tort (including, without limitation, negligence or breach of statutory duty) or otherwise to compensate you for:

- any increased costs or expenses;
- any loss of profit, revenue, business, contracts or anticipated savings;
- any loss or expense resulting from a claim by a third party; or
- any special, indirect or consequential loss or damage of any nature whatsoever caused by Company's failure in complying with its obligations.

The benefits given to you in this warranty are in addition to other rights and remedies under a law in relation to the goods or services to which this warranty applies.

This warranty is not applicable outside Australia.

TO MAKE A CLAIM UNDER THIS WARRANTY, TO DISCUSS YOUR WARRANTY SERVICE OR TO OBTAIN LOCATIONS FOR YOUR NEAREST SERVICE CENTRE, PLEASE CONTACT INTERSOURCE SOLUTIONS PTY LTD ON 1300 985 815.

SPARE PARTS & TECHNICAL SUPPORT

Tel: 1300 985 815
Email: spares@intersource.co

NOTES



PLATINUM

CONTACT DETAILS

AUSTRALIA
PLATINUM APPLIANCES

PO Box 7785
Baulkham Hills BC
NSW 1755

P // 1300 985 815
F // 02 8095 7511
E // platinum@intersource.co

PLATINUM IS COMMITTED TO ONGOING RESEARCH AND DEVELOPMENT. EVERY EFFORT HAS BEEN MADE TO ENSURE ALL INFORMATION IN THIS USER MANUAL IS CORRECT AT TIME OF GOING TO PRINT. DIMENSIONS SHOULD BE USED AS A REFERENCE ONLY AND ACTUAL DIMENSIONS SHOULD BE TAKEN FROM THE PHYSICAL PRODUCT ONLY.

MANUFACTURER RESERVES THE RIGHT TO CHANGE SPECIFICATIONS WITHOUT NOTICE.

| platinumappliances.com.au
VERSION 1.0