

EtherCAT User's Manual

(Version: V1.03)



ESTUN AUTOMATION TECHNOLOGY CO., LTD.

— Drive Your Success!



ESTUN

Content

Chapter 1 Brief introduction of EtherCAT	1
1.1 What is EtherCAT	1
1.2 EtherCAT general introduction	1
1.3 Product introduction.....	1
1.4 CoE terms	2
1.5 Data type	3
1.6 Communication specifications	3
1.7 EC-100 module structure.....	4
1.8 LED indicators	4
Chapter 2 Installation and connection.....	7
2.1 Installation and connection	7
2.2 EtherCAT interface specification.....	7
2.3 Wire specification	8
Chapter 3 EtherCAT-EC information.....	9
3.1 CANopen over EtherCAT model.....	9
3.2 EtherCAT slave information	10
3.3 EtherCAT network state machine	10
3.4 PDO mapping.....	11
3.5 Emergency message.....	13
Chapter 4 Network synchronization based on distributed clocks	14
Chapter 5 CiA402 device protocol	16
5.1 CANopen over EtherCAT(CoE) state machine	16
5.2 Parameters for device control.....	17
5.2.1 controlword.....	18
5.2.2 statusword.....	19
5.2.3 shutdown_option_code	20
5.2.4 disable_operation_option_code	21
5.2.5 quick_stop_option_code	22
5.2.6 halt_option_code	22
5.2.7 fault_reaction_option_code.....	23
5.3 Control mode.....	23
5.4 Control mode parameters	23
5.5 Homing mode	25
5.5.1 Control word.....	25
5.5.2 State word	25
5.5.3 Parameters related to homing mode	26
5.5.4 Homing method	29
5.6 Profile velocity mode	31
5.6.1 Control word.....	31
5.6.2 State word	31
5.6.3 Parameters related to velocity mode.....	31
5.7 Profile position mode	35

5.7.1 Control word	35
5.7.2 State word	36
5.7.3 Parameters related to position control	36
5.7.4 Function description.....	40
5.8 Interpolation position mode.....	42
5.8.1 Control word.....	42
5.8.2 State word	42
5.8.3 Parameters related to interpolation position control.....	42
5.9 Cyclic synchronous position mode.....	45
Chapter 6 EtherCAT communication example.....	47
Appendix A Object dictionary	51
Appendix B Parameters.....	68
Appendix C Standard Wiring Examples	93

Chapter 1 Brief introduction of EtherCAT

1.1 What is EtherCAT

EtherCAT is an open network based on Ethernet to achieve real time control. It could support high speed and synchronized control. By using efficient network topology, the network structure with too many concentrator and complicated connections are avoided. It is very suitable to use this protocol in motion control and other factory automation applications.

1.2 EtherCAT general introduction

EtherCAT technology breaks the limits of normal internet solution. Through this technology, we don't need to receive Ethernet data, decode the data, and then copy the process data to different devices. EtherCAT slave device could read the data marked with this device's address information when the frame passes this device. As the same, some data will be written into the frame when it passes the device. In this way, data reading and data writing could be done within several nanoseconds.

EtherCAT uses standard Ethernet technology and support almost kinds of topologies, including the line type, tree type, star type and so on. Its physical layer could be 100 BASE-TXI twisted-pair wire, 100BASE-FX fiber or LVDS (low voltage differential signaling). It could also be done through switch or media converters or in order to achieve the combination of different Ethernet structure.

Relying on the ASICs for EtherCAT in the slave and DMA technology that reads network interface data, the processing of the protocol is done in the hardware. EtherCAT system could update the information for 1000 I/O within 30 μ s. It could exchange a frame as big as 1486 bytes within 300 μ s. This is almost like 12000 digital output or input. Controlling one servo with 100 8-byte I/O data only takes 100 μ s. Within this period, the system could update the actual positions and status presented by command value and control data. Distributed clock technology could make the cyclic synchronous error lower than 1 μ s.

1.3 Product introduction

ProNet servo drive achieves EtherCAT communication through EC100 network module. It is a real time Ethernet communication and the application layer applies CANopen Drive Profile (CiA 402).

Besides supporting the PV, PP, IP and other control mode defined in CANopen DS402, this module also supports CSP control mode. Clients

could switch the control mode by changing correspondent parameters. It is available from simple velocity control to high speed high precision position control.

1.4 CoE terms

The tables below lists the terms used in CANopen and EtherCAT.

Abbreviation	Description
APRD	Auto Increment Physical Read: a command of EtherCAT Date link layer.
APWR	Auto Increment Physical Write: a command of EtherCAT Date link layer.
APRW	Auto Increment Physical ReadWrite: a command of EtherCAT Date link layer.
ARMW	Auto Increment Physical Read Multiple Write: a command of EtherCAT Date link layer.
BRD	Broadcast Read: a command of EtherCAT Date link layer.
BRW	Broadcast Write: a command of EtherCAT Date link layer.
CiA	CAN in Automation
CoE	CANopen over EtherCAT
DC	Distributed Clocks Mechanism to synchronize EtherCAT slaves and master.
ECAT	EtherCAT
EEPROM	Electrically Erasable Programmable Read Only Memory.
ESC	EtherCAT Slave Controller
ESM	EtherCAT State Machine
ETG	EtherCAT Technology Group(http://www.ethercat.org)
EtherCAT	Real-time Standard for Industrial Ethernet Control Automation Technology(Ethernet for Control Automation Technology)
FMMU	Fieldbus Memory Management Unit
INIT	INIT state of EtherCAT state machine
LRD	Logical Read: a command of EtherCAT Date link Layer
LWR	Logical Write: a command of EtherCAT Date link Layer
LRW	Logical ReadWrite: a command of EtherCAT Date link Layer
OP	Operational state of EtherCAT state machine
OD	Object Dictionary
PDO	Process Data Object
PREOP	Pre-Operational state of EtherCAT state machine
RXPDO	Receive PDO, i.e. Process Date that will be received by ESC
SAFEOP	Safe-Operational state of EtherCAT state machine
SDO	Service Data Object
SyncManager	ESC unit for coordinated data exchange between master and slaver controller
TXPDO	Transmit PDO, i.e. Process Date that will be transmitted by ESC

1.5 Data type

The table below lists all the data types and their range that will be used in this manual.

Code	Data type	Range
UINT8	Unsigned integer 8	0 to 255
INT8	Integer 8	-128 to +127
UINT16	Unsigned integer 16	0 to 65535
INT16	Integer 16	-32768 to +32767
UINT32	Unsigned integer 32	0 to 4294967295
INT32	Signed integer 32	-2147483648 to +2147483627
STR	string	-

1.6 Communication specifications

EtherCAT communication	applied communication standard	IEC 61158 Type12, IEC 61800-7 CiA402 Drive Profile
	Physical layer	100BASE-TX (IEEE802.3)
	Interface	CN5 (RJ45): EtherCAT Signal IN CN6 (RJ45): EtherCAT Signal OUT
	Wiring	Level-5 twisted pair wire
	SyncManager	SM0: output mailbox, SM1: input mailbox SM2: input process data, SM3: Output process data
	FMMU	FMMU0: mapped to output area of process data(RXPDO) FMMU1: mapped to transmit area of process data(TxPDO) FMMU2: mapped to mailbox status
	EtherCAT Commands (Data Link Layer)	APRD, FPRD, BRD, LRD, APWR, FPWR, BWR, LWR, ARMW, FRMW Note: APRW, FPRW, BRW, LRW Commands are not supported.
	PDO data	Dynamic PDO mapping
	Mailbox (CoE)	Emergency Message, SDO Request, SDO Response, SDO information Note: Don't support TxPDO/RxPDO and remote TxPDO/RxPDO.

	Distributed data(DC)	Free-run, DC mode(activated by configuration) supported DC cycle time: 250us – 2ms
	SII	256 bytes(read only)
	LED light	EtherCAT system indicator(SYS)x1 EtherCAT run indicator(RUN)x1 EtherCAT error indicator(ERR)x1
CiA402 Drive Profile		Homing mode Profile position mode Profile velocity mode Cyclic synchronous position mode

1.7 EC-100 module structure

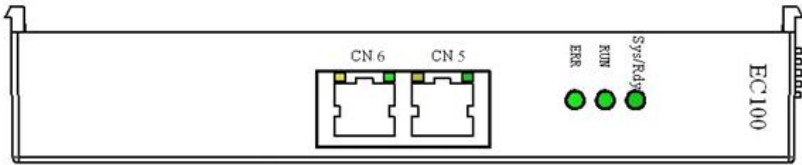

Module structure

1.8 LED indicators

SYS

EC-100 module indicates light, used to show the software status in the module.

LED light(green/yellow)		Introduction
Status	Description	
Off	Continuously off	No power supply or reset status
Flashing(yellow)		Boot mode
On (green)	Continuously on	Module's internal program has finished initiation and operates well.

RUN

RUN light is used to indicate the communication status of EtherCAT

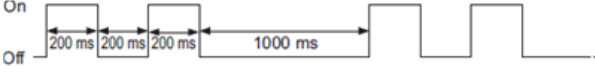
LED indicator(green)		Introduction
Status	Description	
Off	Continuously off	System initiation
Blinking		pre-operation status
Double flashing		safety operation mode
On	Continuously on	Operation status

ERR

ERR light is used to indicate the error in EtherCAT communication.

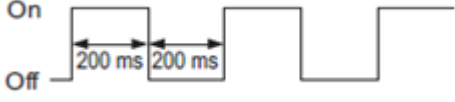
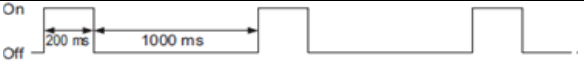
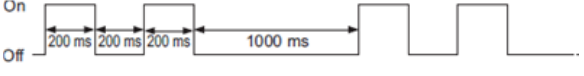
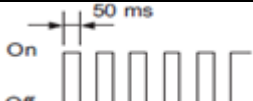
LED light(red)		Introduction
Status	Description	
Off	Continuously off	No error
Blinking		Due to register problem or object configuration problem, the status changing required by the master couldn't be achieved.
Single flash		Sync error. Communication data error
Double flash		Application program supervision overtime. SyncManager watchdog overtime
Flickering		Initiating error

On	Continuously on	PDI supervision overtime
----	-----------------	--------------------------

LINK/ACT (green light on RJ45 COM1/COM2)

LINK/ACT light is used to indicate the physical communication and if there is data exchange.

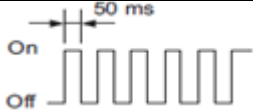
LED light(green)		Introduction
Status	Description	
Off	Continuously off	Physical level communication has not been started. EtherCAT controller has not been started.
Flickering		slave is exchanging data
On	Continuously on	There is connection in link layer but there is no data exchange

Chapter 2 Installation and connection

2.1 Installation and connection

EtherCAT network is normally composed of one master (for example, industrial PC) and some slaves (for example, servo drives, filed bus terminals and so on). Every EtherCAT slave has two standard Ethernet interfaces.

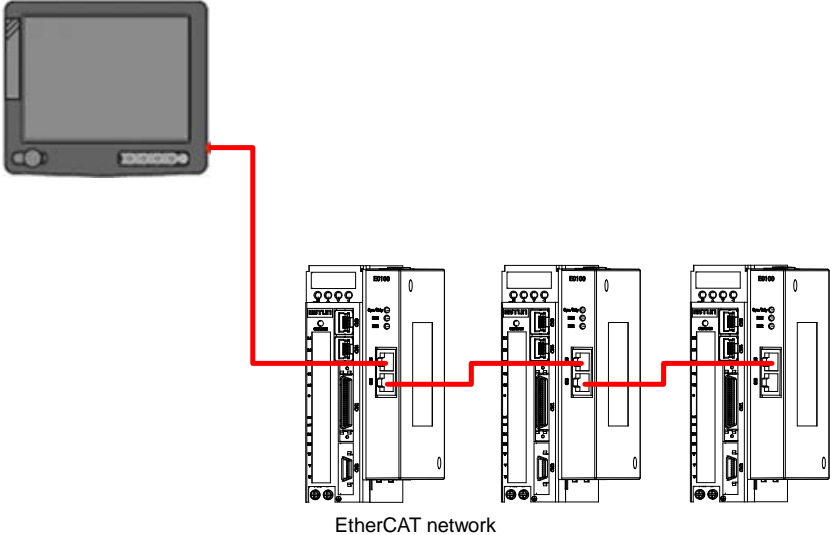

2.2 EtherCAT interface specification

EtherCAT interface should be connected by twisted pair wire

Electrical feature: according to IEEE802.3 standard

Interface: RJ45 8 pin modularize connector (According to ISO 8877)

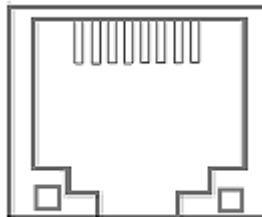

RJ45 connector

RJ45 connector

connector	description
CN5	EtherCAT IN port

CN6

EtherCAT OUT port

Pin layout

Pin No.	Signal name	abbreviation	signal transmit direction
1	Data transmit +	TD +	Output
2	Data transmit -	TD-	Output
3	Data receive +	RD+	Input
4	Not used	-	-
5	Not used	-	-
6	Data receive -	RD-	Input
7	Not used	-	-
8	Not used	-	-
Interface grounding	grounding	FG	-

2.3 Wire specification

Level 5 or above.

Shield

Note: Identify the cable model is suitable for the interface. Identify items are as follows: conductor specification, single cable/pair cable, two pair/ four pair, external diameter etc.

Chapter 3 EtherCAT-EC information

3.1 CANopen over EtherCAT model

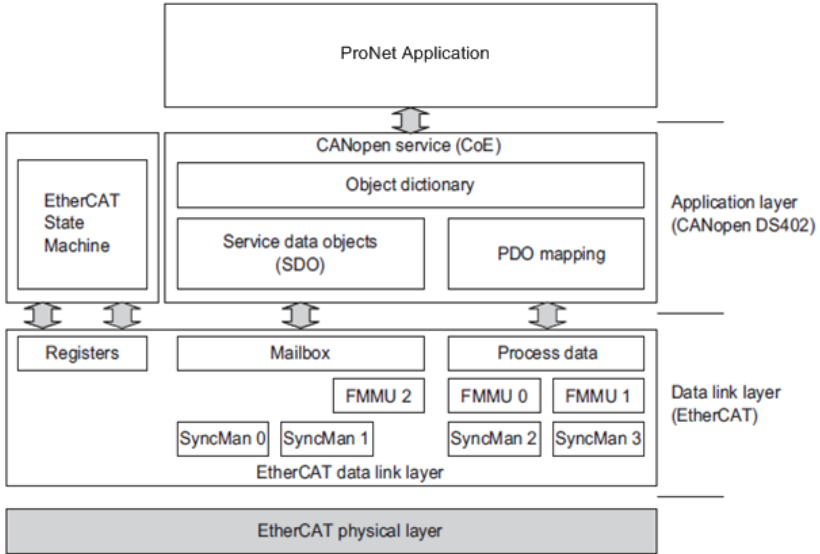

Communication model

EtherCAT (CoE) network model is composed of two parts: data link layer and application layer. Data link layer is mainly in charge of EtherCAT communication protocol. Application layer is mainly oriented to CANOpen drive profiles (DS402) communication protocol. Object dictionary in CoE includes parameters, application data and PDO mapping information.

Process data object (PDO) is composed of objects in the object dictionary that could operate PDO mapping. The content of PDO data is defined by PDO mapping. PDO data's read and write are periodical without checking OD. However, mail communication (SDO) is not periodic. When they are read or written, it is necessary to check OD.

Note: To decode SDO data and PDO data on EtherCAT data link layer correctly, we need to configure FMMU and Sync Manager as below

Sync Manager Configuration

Sync Manager	Assignment(Fixed)	Size	Start Address(Fixed)
Sync Manager 0	Assigned to Receive Mailbox	128byte(Fixed)	0x1000
Sync Manager 1	Assigned to Transmit Mailbox	128byte(Fixed)	0x1080
Sync Manager 2	Assigned to Receive PDO	0 to 200byte	0x1100
Sync Manager 3	Assigned to Transmit PDO	0 to 200byte	0x1358

FMMU Settings

FMMU	Settings
FMMU 0	Mapped to Receive PDO
FMMU 1	Mapped to Transmit PDO
FMMU 2	Mapped to Fill Status of Transmit Mailbox

3.2 EtherCAT slave information

EtherCAT slave information (XML document) could be read by the master to build the master-slave configuration. ESTUN ProNet servo drive offers document as below

ESTUN_ProNet_CoE.xml

3.3 EtherCAT network state machine

EtherCAT state machine is used to describe the states that one slave applies and the state change. State change request is normally launched by the master and answered by the slave.

The graph below describes the slave's state machine.

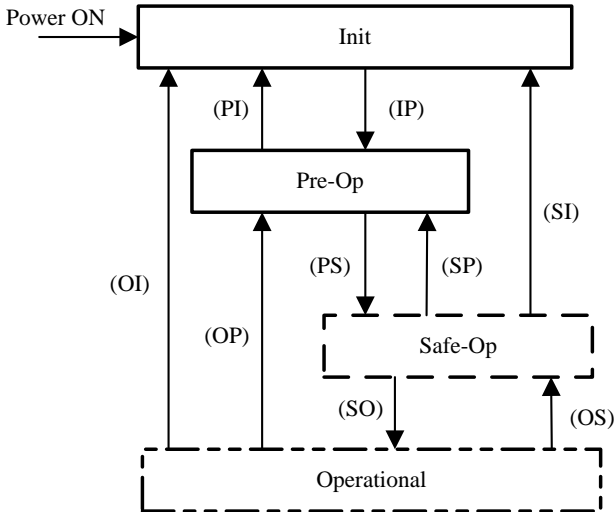

Status	Description
Init	No mailbox communication No process data communication

Status	Description
Init to Pre-Op	Master configures data link layer address and initiate mailbox communication Master initializes DC clock synchronization. Master requests to change into Pre-op status. Master sets AL control register. Slave checks if mailbox initialization is good.
Pre-Operation (Pre-Op)	Mailbox communication is activated. Process data communication is not available.
Pre-Op to Safe-Op	Master configures SyncManager channels and FMMU channels for process data. Master configures PDO mapping and the sync manager PDO assignment parameters via SDO. Master requests 'Safe-Operational' state. Slave checks whether the sync manager channels for process data communication and, if required, the distributed clocks settings are correct.
Safe-Operation(Safe-Op)	Slave's program will transmit actual input data and will not execute output. Output is set as safety status.
Safe-Op to Op	Master transmits effective output data. Master asks to change into OP status.
Operational(Op)	Process data communication is available now.

3.4 PDO mapping

Process data of EtherCAT slaves is composed by SyncMangaer channels. Each SyncMangaer channel describes the consistent area of process data. EtherCAT slaves with application control function should support PDO mapping and SM-PDO-Assign object reading.

PDO mapping

PDO mapping is related to the mapping from object dictionary to PDO's application objects (real time process data).

The index 0x1600 and 0x1A00 in object dictionary are separately reserved for the mapping tables of RXPDO and TxPDOs. The graph as below is one example.

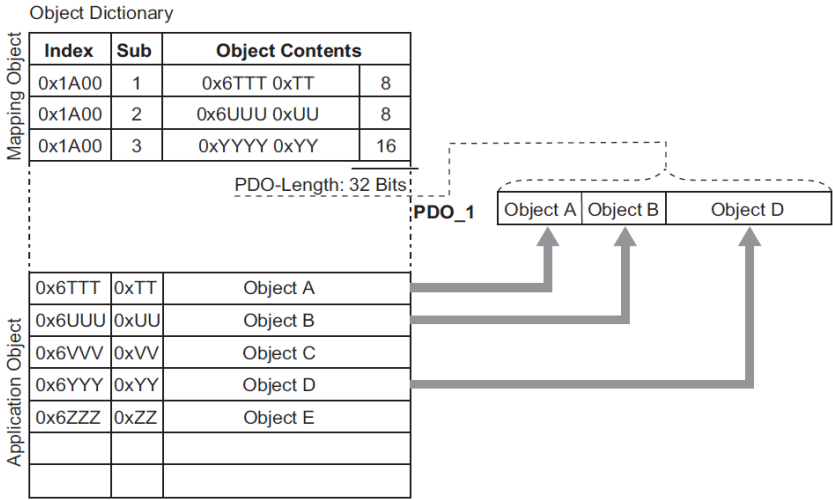

PDO mapping example

PDO configuration

Sync manager object (SMCO) is composed of multiple PDOs. SM-PDO-Assign object (0x1C12 and 0x1C13) describes the relationship between PDOs and Sync Manager as below

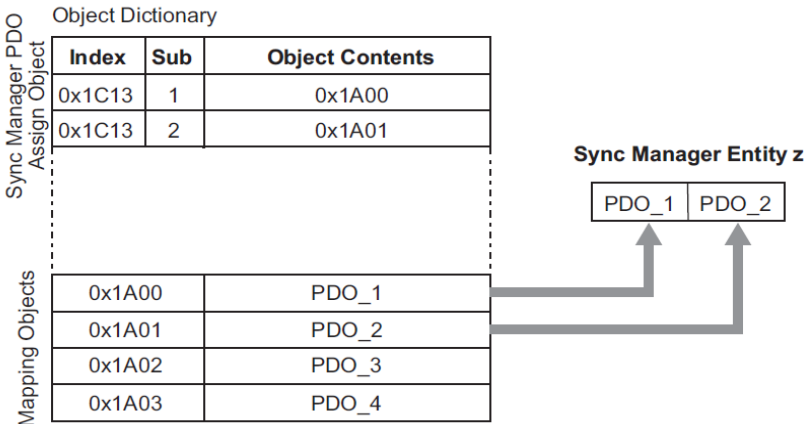

PDO configuration example

Note: The PDO mapping objects (index 1600h to 1603h, 1A00h to 1A03h) and the Sync Manager PDO assign objects (Index 1C12h and 1C13h) can be written only in Pre-Operation state.

PDO mapping process

- Stop PDO allocating function (set the sub-index 0 of 0x1c12 and 0x1c13 into 0).
- Stop PDO mapping function (set sub-index 0 of 0x1600~0x1603 and 0x1A00~0x1A03 into 0).

Set the number of mapping entries in PDO mapping objects (Set sub-index 0 of object 0x1600h to 0x1603h/0x1A00h to 0x1A03h).

Set the assignment of the Sync manager and PDO (Set sub index 1 of object 0x1C12h and 0x1C13h)

Enable the assignment of the Sync manager and PDO (Set sub index 0 of object 0x1C12h and 0x1C13h to 1).

Over again open PDO assignment function (set the sub-index 0 of 0x1c12 and 0x1c13 into 1)

3.5 Emergency message

When the servo drive generates an alarm, Coe will activate an emergency message and inform consumers the current servo drive model number and error code.

Emergency message structure:

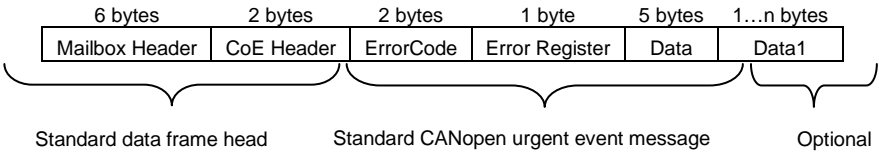

Byte	0	1	2	3	4	5	6	7
Data	Emergency Error Code		Error Register (Object 1001h)	Reserved	Manufacturer Specific Error Field			
					ProNet Alarm/Warning Code*2		Reserved	

Chapter 4 Network synchronization based on distributed clocks

Any slave in the EtherCAT network can be used as reference clock for the whole network. It provides system time. And the distribute clock in slave device synchronizes with the reference clock. It enables slave's local application to synchronize with reference clock events.

EC-netX50 model achieves the synchronous mode as following. Switching synchronous mode can be controlled by synchronous control register (ESC 0x980 and 0x981).

- Free-Run mode (ESC register: 0x980 = 0x0000)

In this mode, local application cycle, communication cycle and master cycle is independent.

DC mode (ESC register: 0x980 = 0x0300)

In this mode, local application is synchronous with Sync0.

Index	Sub	Name	Access	PDO Mapping	Type	Value
0x1C32	Sync Manager channel 2 (process data output) Synchronization					
	1	Synchronization type	RO	No	UINT	Current status of DC mode 0: Free-run 2: DC Mode (Synchronous with Sync0)
	2	Cycle time	RO	No	UINT	Sync0 event cycle [ns] (The value is set by master via ESC register.) range: 125000*n (n = 2–16) [ns]
0x1C33	Sync Manager channel 3 (process data input) Synchronization					
	3	Shift time	RO	No	UINT	–
	6	Calc and copy time	RO	No	UINT	–

Time schedule figure in DC mode is as follows:

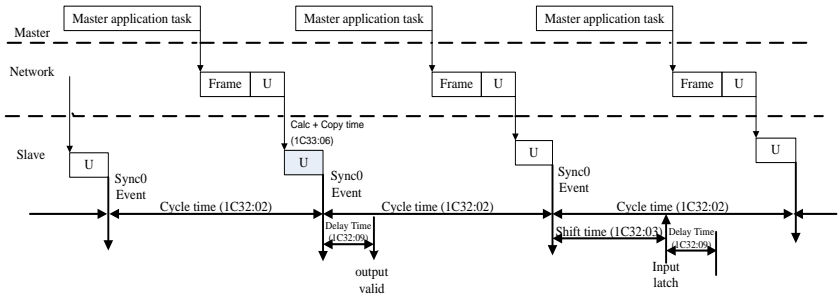

Time schedule figure in DC mode

Chapter 5 CiA402 device protocol

ProNet's device control is used mainly to achieve the motion control in different control modes. The master controls the servo drive through control word and knows the status of the servo drive by reading the servo drive's status word.

5.1 CANopen over EtherCAT(CoE) state machine

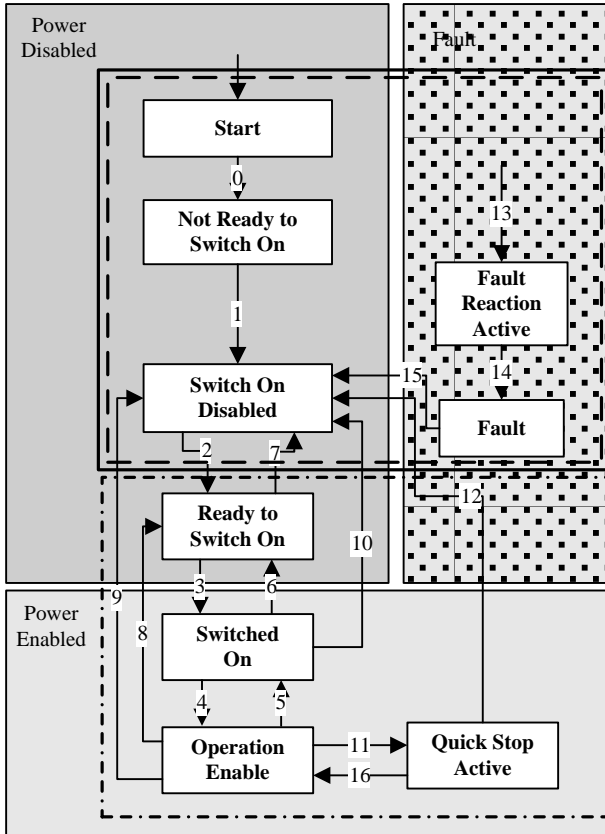

CANopen state machine

As above, the state machines could be divided into 3 parts: “power disabled”, “power enabled” and “fault”. All the states will be into “Fault” status after alarm. After power enabled, servo drive will finish initiating and then enter SWITTECH_ON_DISA status. Now we could configure the servo drive, for example, set the working mode of the servo drive as profile position mode.

At this time, the main power supply is still shut down and the servo

motor is now excited. After the state transition 2, 3 and 4, the servo drive will be in OPERATION ENABLE mode. At this time, the main power will be switched on and servo drive starts to control the servo motor according to the configured working mode. So, before this state, we must ensure the servo drive's parameters are correct. State Transition 9 will be used to shut down the main power supply. Once alarm happens to the servo drive, the servo drive's state will be in FAULT state.

States	Description
Not Ready to Switch On	Servo drive is initiating.
Switch On Disabled	Initiation completed.
Ready to Switch On	Servo drive enters Switch On state. The servo motor is not servo-on yet.
Switched On	Servo drive ready and main power is on
Operation Enable	Servo on and control the servo motor according to the control mode.
Quick Stop Active	Servo drive stops in pre-defined method
Fault Reaction Active	Servo drive detects alarm and stop according to pre-defined method. Servo motor is still on.
Fault	Servo off

5.2 Parameters for device control

Index	Object	Name	Type	Attr.
6040 _h	VAR	Controlword	UINT16	RW
6041 _h	VAR	Statusword	UINT16	RO
605A _h	VAR	Quick stop option code	INT16	RW
605B _h	VAR	Shutdown option code	INT16	RW
605C _h	VAR	Disabled operation option code	INT16	RW
605D _h	VAR	Halt option code	INT16	RW
605E _h	VAR	Fault reaction option code	INT16	RW

5.2.1 controlword

Index	6040 _h
Name	Control word
Object Code	VAR
Data Type	UINT16
Access	RW
PDO Mapping	YES
Units	--
Value Range	--
Default Value	0

Control word bit description:

15	11	10	9	8	7	6	4	3	2	1	0
manufacturer specific	reserved	halt	Fault reset	Operation mode specific	Enable operation	Quick stop	Enable voltage	Switch on			

Bit0 ~ 3 and Bit7:

The transmission of state machine will be triggered by the command composed by these 5 bits.

Device control command list

Command	Bit of the controlword					
	Fault reset	Enable operation	Quick stop	Enable voltage	Switch on	Transitions
Shutdown	0	x	1	1	0	2,6,8
Switch on	0	0	1	1	1	3*
Switch on	0	1	1	1	1	3**
Disable voltage	0	x	x	0	x	7,9,10,12
Quick stop	0	x	0	1	x	7,9,10,11
Disable operation	0	0	1	1	1	5
Enable operation	0	1	1	1	1	4,16
Fault reset		x	x	x	x	15

Note: X means this bit could be ignored.

Bit4, 5, 6, 8:

In different control mode, these 4 bits' definition will be different.

Bit	Control mode		
	profile position mode	profile velocity mode	homing mode
4	New set point	reserved	Start homing operation
5	Change set immediately	reserved	reserved
6	abs/rel	reserved	reserved
8	Halt	Halt	Halt

The other bits: All reserved.

5.2.2 statusword

Index	6041 _n
Name	statusword
Object Code	VAR
Data Type	UINT16
Access	RO
PDO Mapping	YES
Units	--
Value Range	--
Default Value	--

Statusword bit introduction is as below

bit	introduction
0	Ready to switch on
1	Switched on
2	Operation enabled
3	Fault
4	Voltage enabled
5	Quick stop
6	Switch on disabled
7	Warning
9~8	reserved
10	Target reached
11	Internal limit active
13~12	Operation mode specific
15~14	reserved

Bit0 ~ 3 , Bit5 and Bit6:

The combination of these bits represents the status of the servo drive

Value(binary)	State
xxxx xxxx x0xx 0000	Not ready to switch on
xxxx xxxx x1xx 0000	Switch on disabled
xxxx xxxx x01x 0001	Ready to switch on
xxxx xxxx x01x 0011	Switched on
xxxx xxxx x01x 0111	Operation enabled
xxxx xxxx x00x 0111	Quick stop active
xxxx xxxx x0xx 1111	Fault reaction active
xxxx xxxx x0xx 1000	Fault

Bit4: Voltage enabled

When this bit is **1**, it means the main power is on.

Bit5: Quick stop

When this bit is **0**, it means the servo drive will stop the servo motor according to the configuration(605A n: quick_stop_option_code)

Bit7: Warning

When the bit is **1**, it means the servo drive detects alarm.

Bit10: Target reached

In different control mode, this bit has different meanings.

In **Profile Position Mode**, when the set position is reached, this bit will be set as 1. When Halt is activated and speed decreases to zero, this bit will be set as 1. When a new position is set, this bit will be cleared.

In **Profile Velocity Mode**, when the speed reaches the required speed, this bit will be set as 1. When Halt is activated, the speed will decrease to zero and this bit will be set as 1.

Bit11: Internal limit active

When this bit is **1**, it means that the internal torque has surpassed the set value.

Bit12, 13:

These two bits in different control mode have different meaning.

Bit	Control mode		
	profile position mode	profile velocity mode	homing mode
12	Set-point acknowledge	Speed	Homing attained
13	Following error	Max slippage error	Homing error

The other bits: All reserved

5.2.3 shutdown_option_code

When **Operation Enable** mode is transit to **Ready to Switch On** status, Shutdown_option_code will be used to define how to stop the servo motor.

Index	605B _h
Name	Shutdown option code
Object Code	VAR
Data Type	INT16
Access	RW
PDO Mapping	NO
Units	--
Value Range	0,1
Default Value	0

value	Introduction
0	Shutdown servo excitation signal. Servo motor will stop freely.
1	After the servo motor decelerates and stops, the servo excitation signal will be shut down.

5.2.4 disable_operation_option_code

When the status of **Operation Enable** transits to **Switched On** status, **disable_operation_option_code** will decide how to halt.

Index	605C _h
Name	Disable operation option code
Object Code	VAR
Data Type	INT16
Access	RW
PDO Mapping	NO
Units	--
Value Range	0,1
Default Value	0

Value	Introduction
0	Shutdown servo excitation signal. Servo motor will stop freely.
1	After the servo motor decelerates and stops, the servo excitation signal will be shut down.

5.2.5 quick_stop_option_code

When the **Operation Enable** status transits to **Quick Reaction Active** status, quick_stop_option_code will define how to stop.

Index	605A _h
Name	quick_stop_option_code
Object Code	VAR
Data Type	INT16
Access	RW
PDO Mapping	NO
Units	--
Value Range	0,1,2,5,6
Default Value	0

Value	Introduction
0	Shutdown servo excitation signal. Servo motor will stop freely.
1	After the servo motor decelerates and stops, the servo excitation signal will be shut down.
2	After servo motor stops urgently, the servo excitation signal will be shut down.
5	After the servo motor decelerates to zero, it will still stay in QuickStop status.
6	After the servo motor stops urgently, it will still stay in QuickStop status.

5.2.6 halt_option_code

When bit8 of Controlword is 1, halt option code will define how to halt. .

Index	605D _h
Name	halt_option_code
Object Code	VAR
Data Type	INT16
Access	RW
PDO Mapping	NO
Units	--
Value Range	1,2
Default Value	0

Value	Introduction
1	Servo motor will decelerate gradually to zero
2	Servo motor will decelerate urgently and then stop.

5.2.7 fault_reaction_option_code

When it alarms, **fault_reaction_option_code** will decide how to halt. .

Index	605D _h
Name	fault_reaction_option_code
Object Code	VAR
Data Type	INT16
Access	RW
PDO Mapping	NO
Units	--
Value Range	0
Default Value	0

Value	Introduction
0	The servo excitation signal will be shut down and servo motor will stop freely.

5.3 Control mode

Now, ProNet servo drive supports 5 control modes:

HOMING MODE

PROFILE VELOCITY MODE

PROFILE POSITION MODE

CYCLIC SYNCHRONIZATION POSITION MODE

INTERPOLATION POSITION MODE

This chapter will mainly describe these 5 control methods as above.

5.4 Control mode parameters

Index	Object	Name	Type	Attr.
6060 _h	VAR	modes_of_operation	INT8	RW
6061 _h	VAR	modes_of_operation_display	INT8	RO

modes_of_operation

Servo drive's control mode is defined by modes_of_operation.

Index	6060 _h
Name	modes_of_operation
Object Code	VAR
Data Type	INT8
Access	RW
PDO Mapping	YES
Units	--
Value Range	1,3,6
Default Value	0

Value	Introduction
0	Not any control mode
1	PROFILE POSITION MODE
3	PROFILE VELOCITY MODE
6	HOMING MODE
8	CYCLIC SYNCHRONIZATION POSITION

modes_of_operation_display

Servo drive's current control mode could be read from the modes_of_operation_display.

Index	6061 _h
Name	modes_of_operation_display
Object Code	VAR
Data Type	INT8
Access	RO
PDO Mapping	YES
Units	--
Value Range	1,3,6,7,8
Default Value	0

Note:

Only through the parameters of **modes_of_operation_display**, we could get the control mode of the servo drive.

Only in **Target Reached** status, servo drive's control mode can be transit to configured control mode. And then **modes_of_operation_display** could be the same as **modes_of_operation**.

5.5 Homing mode

PRONET servo drive now supports multiple homing methods. Clients could choose the homing method that suits the motor type and application. For example, if the servo drive uses incremental encoder, we could choose C pulse to do the homing. If the servo drive is using serial encoder or resolver, we couldn't use C pulse as the homing method.

Clients can set homing method, homing speed and acceleration. After the servo drive finds the reference point, we could also set the distance between homing position and reference point as much as the value defined by `home_offset` (607C_h).

5.5.1 Control word

15 ~ 9	8	7 ~ 5	4	3 ~ 0
*	Halt	*	home_start_operation	*

*: please referred to previous chapters

Name	Value	Description
Homing operation start	0	Homing mode inactive
	0 → 1	Start homing mode
	1	Homing mode active
	1 → 0	Interrupt homing mode
Halt	0	Execute the instruction of bit 4
	1	Stop axle with homing acceleration

5.5.2 State word

15 ~ 14	13	12	11	10	9 ~ 0
*	homing_error	homing_attained	*	target_reached	*

*: Please refer to the previous chapters

Name	Value	Description
Target reached	0	Halt = 0: Home position not reached Halt = 1: Axle decelerates
	1	Halt = 0: Home position reached Halt = 1: Axle has velocity 0
Homing attained	0	Homing mode not yet completed
	1	Homing mode carried out successfully
Homing error	0	No homing error
	1	Homing error occurred; Homing mode carried out not successfully; The error cause is found by reading the error code

5.5.3 Parameters related to homing mode

Index	Object	Name	Type	Attr.
607C _h	VAR	home_offset	INT32	RW
6098 _h	VAR	homing_method	INT8	RW
6099 _h	ARRAY	homing_speeds	UINT32	RW
609A _h	VAR	homing_acceleration	INT32	RW

home_offset

Home_offset defines the distance between reference position and homing position.

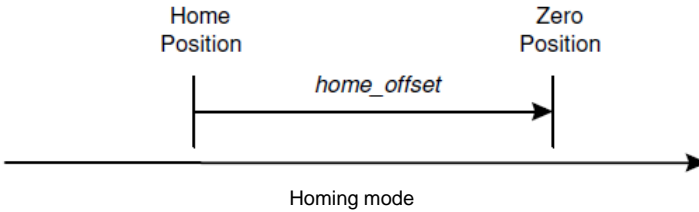

Index	607C _h
Name	home_offset
Object Code	VAR
Data Type	INT32
Access	RW
PDO Mapping	YES
Units	position units
Value Range	--
Default Value	0

homing_method

There are 4 signals as homing signals: positive limit switch, negative limit switch, reference position switch and C pulse.

Index	6098 _h
Name	homing_method
Object Code	VAR
Data Type	INT8
Access	RW
PDO Mapping	YES
Units	--
Value Range	1,2,3,4,17,18,19,20
Default Value	1

Homing method table

Method	Direction	Target position	Reference Position	DS402
1	negative	NOT	C pulse	1
2	positive	POT	C pulse	2
3	negative	reference position switch	C pulse	3
4	positive	Reference position switch	C pulse	4
17	negative	NOT	NOT	17
18	positive	POT	POT	18
19	negative	reference position switch	reference position switch	19
20	positive	reference position switch	reference position switch	20
35	--	currently position	currently position	35

homing_speeds

Two kinds of speed are used in finding the reference position: The speed to find reference position and the speed to find zero position.

Index	6099 _h
Name	homing_speeds
Object Code	ARRAY
No. of Elements	2
Data Type	INT32

Sub-Index	01 _h
Name	speed_during_search_for_switch
Object Code	VAR
Data Type	INT32
Access	RW
PDO Mapping	YES
Units	speed units
Value Range	--
Default Value	0

Sub-Index	02 _h
Name	speed_during_search_for_zero
Object Code	VAR
Data Type	INT32
Access	RW
PDO Mapping	YES
Units	speed units
Value Range	--
Default Value	0

homing_acceleration

Acceleration and deceleration in homing are all defined by homing_acceleration.

Index	609A _h
Name	homing_acceleration
Object Code	VAR
Data Type	INT32
Access	RW
PDO Mapping	YES
Units	acceleration units
Value Range	--
Default Value	0

5.5.4 Homing method

Homing method 1: Use C pulse and negative limit switch

Servo drive needs to move at first toward negative direction fast till reaching the negative limit switch and then decelerate till stop. And then, servo motor will be bounced back slowly and find the target homing position. Under this homing method, the target homing position is the first C pulse away from the limit switch.

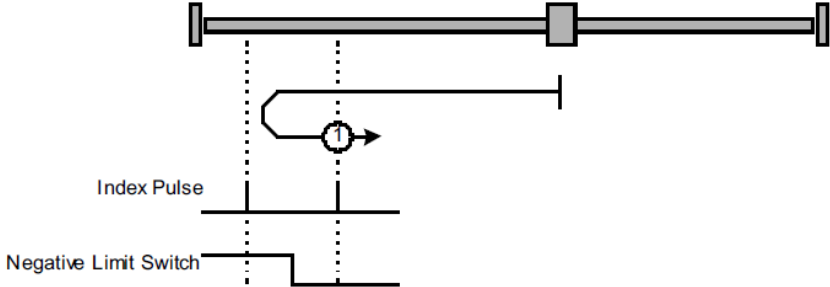

Homing method 2: Use C pulse and positive limit switch

At first servo motor will move fast toward positive direction and decelerate to stop after reaching the positive limit switch. And then servo motor will be bounced back slowly to find homing position. Under this homing method, the target homing position is the first C pulse away from the limit switch.

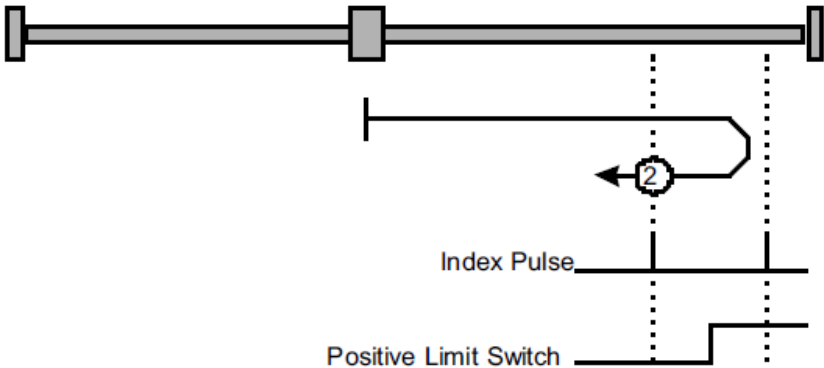

Home method 3 and 4: Use C pulse and reference limit switch

Servo drive's initial moving direction is relied on the status of reference point limit switch. The target homing position is on the left side or right side of the reference limit switch. The distance between the reference position switch and homing position is one C pulse.

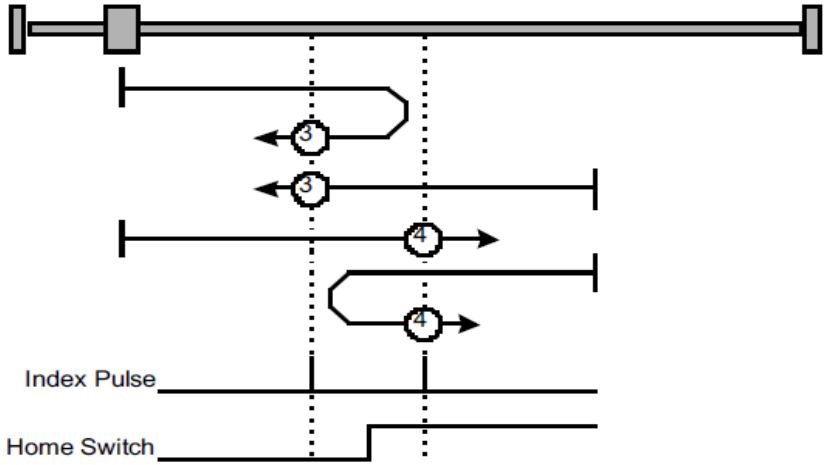

Homing method 17 ~ 20

Not to use C pulse

These 4 homing methods are similar to approach 1-4 but the target homing position is not relied on C pulse any more but on the change of limit switch or reference point. For example, as below, method 19 and method 20 are just similar to method 3 and method 4.

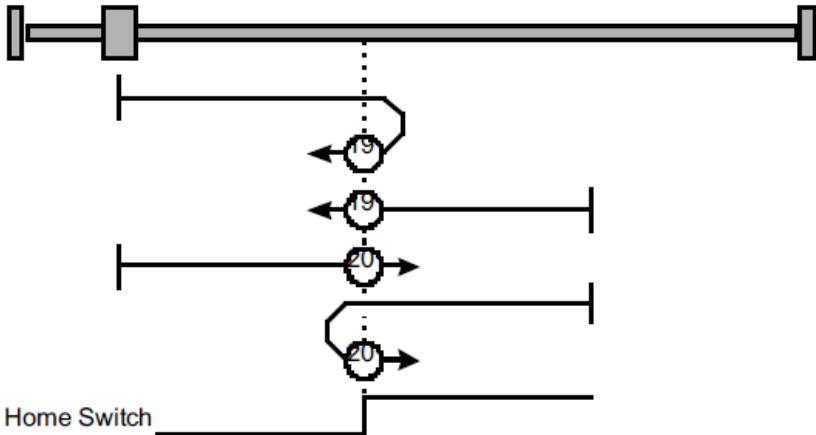

Homing method 35: set current position as the homing point.

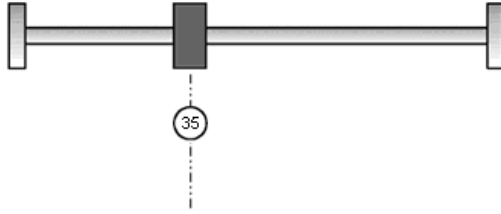

5.6 Profile velocity mode

5.6.1 Control word

15 ~ 9	8	7 ~ 4	3 ~ 0
*	Halt	*	*

*: Refer to previous chapters

Name	Value	Description
Halt	0	Execute the motion
	1	Stop axle

5.6.2 State word

15 ~ 14	13	12	11	10	9 ~ 0
*	MaxSlippageError	Speed	*	Target reached	*

*: Refer to previous chapters

Name	Value	Description
Target reached	0	Halt = 0: Target position not reached Halt = 1: Axle decelerates
	1	Halt = 0: Target velocity reached Halt = 1: Axle has velocity 0
Speed	0	Speed is not equal 0
	1	Speed is equal 0
Max slippage error	0	Maximum slippage not reached
	1	Maximum slippage reached

5.6.3 Parameters related to velocity mode

Index	Object	Name	Type	Attr.
6069 _h	VAR	velocity_sensor_actual_value	INT32	RO

606B _h	VAR	velocity_demand_value	INT32	RO
606C _h	VAR	velocity_actual_value	INT32	RO
609D _h	VAR	velocity_window	UINT16	RW
606E _h	VAR	velocity_window_time	UINT16	RW
606F _h	VAR	velocity_threshold	UINT16	RW
6070 _h	VAR	velocity_threshold_time	UINT16	RW
60FF _h	VAR	target_velocity	INT32	RW

velocity_sensor_actual_value

The master could read **velocity_sensor_actual_value** to know the current velocity. The parameter's unit is internal speed unit.

Index	6069 _h
Name	velocity_sensor_actual_value
Object Code	VAR
Data Type	INT32
Access	RW
PDO Mapping	YES
Units	0.1rmps (1R/10min)
Value Range	--
Default Value	--

velocity_demand_value

Master can read **velocity_demand_value** to know the current reference speed value of the servo drive. The unit of this parameter is user's velocity unit.

Index	606B _h
Name	velocity_demand_value
Object Code	VAR
Data Type	INT32
Access	RO
PDO Mapping	YES
Units	speed units
Value Range	--
Default Value	--

velocity_actual_value

The master can read **velocity_actual_value** to know the current velocity of the servo motor. The unit of this parameter is user's velocity unit.

Index	606C _h
Name	velocity_actual_value
Object Code	VAR
Data Type	INT32
Access	RO
PDO Mapping	YES
Units	speed units
Value Range	--
Default Value	--

velocity_window

The difference between **velocity_actual_value** (606C_h) and **target_velocity** (60FF_h) is defined as actual velocity error window. If the actual velocity error window is always smaller than **velocity_window**(606D_h) within the time set by **velocity_window_time**(606E_h), then bit 10 of status word (target_reached) will be set as 1 to indicate that the set velocity has been reached.

Index	606D _h
Name	velocity_window
Object Code	VAR
Data Type	UINT16
Access	RW
PDO Mapping	YES
Units	speed units
Value Range	--
Default Value	20 R/10min

velocity_window_time

Velocity window comparator is composed of **velocity_window_time** and **velocity_window**.

Index	606E _h
Name	velocity_window_time
Object Code	VAR
Data Type	UINT16
Access	RW
PDO Mapping	YES
Units	ms
Value Range	--
Default Value	0

velocity_threshold

Velocity_threshold indicates a range close to zero speed in order to define if the servo motor has already stopped.

Index	606F _h
Name	velocity_threshold
Object Code	VAR
Data Type	UINT16
Access	RW
PDO Mapping	YES
Units	speed units
Value Range	--
Default Value	10 R/10min

velocity_threshold_time

Velocity_threshold_time is used to set the shortest time when servo motor's speed is under velocity threshold. The unit is: **ms**. When the time that servo motor's speed is lower than the threshold is more than **velocity_threshold_time**, status word bit 12(speed is zero) will be set as **1**.

Index	6070 _h
Name	velocity_threshold_time
Object Code	VAR
Data Type	UINT16
Access	RW
PDO Mapping	YES
Units	ms
Value Range	--
Default Value	0

target_velocity

Target_velocity is reference speed.

Index	60FF _h
Name	target_velocity
Object Code	VAR
Data Type	INT32
Access	RW
PDO Mapping	YES
Units	speed units
Value Range	--
Default Value	0

5.7 Profile position mode

5.7.1 Control word

15 ~ 9	8	7	6	5	4	3 ~ 0
*	Halt	*	abs / rel	change set immediately	New set-point	*

*: Please refer to previous chapters

Name	Value	Description
New Set-point	0	Does not assume target position
	1	Assume target position
Change set immediately	0	Finish the actual positioning and then start the next positioning
	1	Interrupt the actual positioning and start the next positioning

Abs/rel	0	Target position is an absolute value
	1	Target position is a relative value
Halt	0	Execute positioning
	1	Stop axle with profile deceleration (if not supported with profile acceleration)

5.7.2 State word

15 ~ 14	13	12	11	10	9 ~ 0
*	Following error	Set_point acknowledge	*	Target reached	*

*: please refer to previous chapters

N-ame	Value	Description
Target reached	0	Halt = 0: Target position not reached Halt = 1: Axle decelerates
	1	Halt = 0: Target position reached Halt = 1: Velocity of axle is 0
Set-point acknowledge	0	Trajectory generator has not assumed the positioning values (yet)
	1	Trajectory generator has assumed the positioning values
Following error	0	No following error
	1	Following error

5.7.3 Parameters related to position control

Index	Name	Type	Attr.	PDO Mapping	M/O
6040 _h	Control word	UINT16	RW	YES	M
6041 _h	Statusword	UINT16	RO	YES	M
607A _h	target_position	INT32	RW	YES	M
607B _h	Positin_range_limit	INT32	RW	NO	O
6081 _h	profile_velocity	UINT32	RW	YES	M
6082 _h	end_velocity	UINT32	RW	YES	O
6083 _h	profile_acceleration	UINT32	RW	YES	O
6084 _h	profile_deceleration	UINT32	RW	YES	O
6085 _h	quick_stop_deceleration	UINT32	RW	YES	O
6086 _h	motion_profile_type	INT16	RW	YES	M

target_position

Target_position is reference position and this position could be an incremental value or an absolute value. It is up to bit6 of control word.

Index	607A _h
Name	target_position
Object Code	VAR
Data Type	INT32
Access	RW
PDO Mapping	YES
Units	position units
Value Range	--
Default Value	0

profile_velocity

Profile_velocity is the speed that the servo motor could finally reach after acceleration.

Index	6081 _h
Name	profile_velocity
Object Code	VAR
Data Type	UINT32
Access	RW
PDO Mapping	YES
Units	speed units
Value Range	--
Default Value	0

end_velocity

End_velocity is the speed when servo motor reaches the **target_position**. Normally we set this value as **0** in order to stop the servo motor when the servo motor reaches the requested position. But in continuous multiple position, this value could be set as a non-zero value.

Index	6082 _h
Name	end_velocity
Object Code	VAR
Data Type	UINT32
Access	RW
PDO Mapping	YES
Units	speed units
Value Range	--
Default Value	0

profile_acceleration

Profile_acceleration is the acceleration speed before reaching the target position.

Index	6083 _h
Name	profile_acceleration
Object Code	VAR
Data Type	UINT32
Access	RW
PDO Mapping	YES
Units	acceleration units
Value Range	--
Default Value	100000 R/10min/s

profile_deceleration

Profile_deceleration is the deceleration speed before reaching the target position.

Index	6084 _h
Name	profile_deceleration
Object Code	VAR
Data Type	UINT32
Access	RW
PDO Mapping	YES
Units	acceleration units
Value Range	--
Default Value	100000 R/10min/s

quick_stop_deceleration

Quick_stop_deceleration is the deceleration speed in Quick Stop.

Index	6085 _h
Name	quick_stop_deceleration
Object Code	VAR
Data Type	UINT32
Access	RW
PDO Mapping	YES
Units	acceleration units
Value Range	--
Default Value	200000 R/10min/s

motion_profile_type

Motion_profile_type is used to select the motion curve. Now we only support trapezoid speed curve.

Index	6086 _h
Name	motion_profile_type
Object Code	VAR
Data Type	INT16
Access	RW
PDO Mapping	YES
Units	--
Value Range	0
Default Value	0

5.7.4 Function description

There are two methods to allocate a reference position.

Single step setting:

After reaching the target position, servo drive will inform the master that **Reach the target position**. And the servo drive will start new motion after getting new target position. Before getting the new reference position, the velocity of the servo motor is zero.

Continuous setting:

After reaching the target position, the servo motor will keep moving toward next target position which is set in advance. In this way, the servo motor could move continuously without pause. Between two reference positions, the servo motor doesn't need to decelerate to zero.

Above two methods could be switched to each other by using control word bit 4, bit 5 and status word bit 12 (**set_point_acknowledge**) in real time. Through handshaking mechanism, we could pause the position control in the process and use these bits above to reset the target position and then re-active and operate.

Single step setting procedure:

At first, set the NMT status into Operational and set the control mode parameter (6060_h) as 1.

According to the actual demand, we could set the target position (**target_position**: 607A_h) and so on.

We need set bit4 (**new_set_point**) of the control word as 1, bit 5

(**change_set_immediately**) as 0, bit 6 (absolute/comparative) should be determined by whether the reference target position is an absolute value or a comparative value.

We use bit12 (**set_point_acknowledge**) of the status word to configure the servo drive acknowledge mechanism. And then we start to operate position control. After reaching the target position, servo drive will need to respond through bit 10 (**target_reached**) of the status word. And then servo drive will follow the program to keep moving or accept new target position.

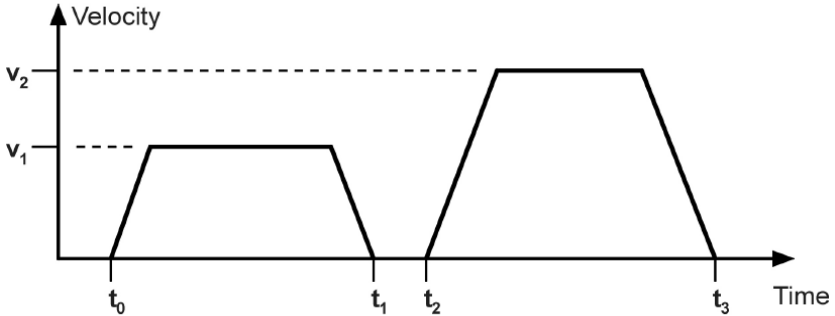

Continuous step setting procedure:

- 1 At first, we need to set NMT status into operational and set control mode (6060_h) as 1. According to actual demand, we need to set the first target position (**target_position**: 607A_h), target speed, acceleration/deceleration and other relevant parameters.

Set bit 4 (**new_set_point**) of control word as 1. Set bit 5 (**change_set_immediately**) as 0. Set bit6 (absolute/comparative) according to the type of object position.

Set bit 12 (**set_point_acknowledge**) of the status word and then start to operate position control.

Set the second target position (**target_position**: 607A_h), target speed, acceleration/deceleration speed.

Set bit4 (**new_set_point**) as 1, bit 5 (**change_set_immediately**) as 0. Set Bit6 (absolute/comparative) according to the target position type.

After reaching the first target position, the servo drive will not stop and keep moving toward the second target position. After reaching the second target position, the servo drive will respond through status word bit 10 (**target_reached**). And then the servo motor will follow the program to keep moving or accept new target position.

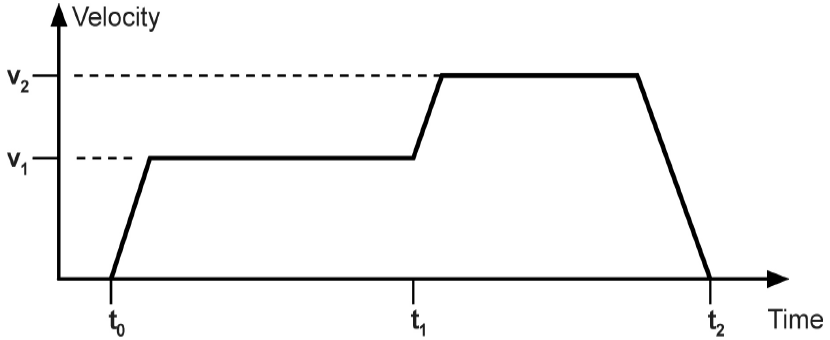

5.8 Interpolation position mode

5.8.1 Control word

15 ~ 9	8	7	6	5	4	3 ~ 0
*	Halt	*	*	*	Enable ip mode	*

*: please referred to previous chapters

Name	Value	Description
Enable ip mode	0	Interpolated position mode inactive
	1	Interpolated position mode active
Halt	0	Execute the instruction of bit 4
	1	Stop axle

5.8.2 State word

15 ~ 14	13	12	11	10	9 ~ 0
*	*	ip mode active	*	Target reached	*

*: please referred to previous chapters

Name	Value	Description
Target reached	0	Halt = 0: Target position not (yet) reached Halt = 1: Axle decelerates
	1	Halt = 0: Target position reached Halt = 1: Velocity of axle is 0
ip mode active	0	Interpolated position mode inactive
	1	Interpolated position mode active

5.8.3 Parameters related to interpolation position control

Index	Object	Name	Type	Attr.
60C0 h	VAR	Interpolation sub mode select	INT16	RW

60C1 h	ARRAY	Interpolation data record	INT32	RW
60C2 h	RECORD	Interpolation time period		RW

Interpolation sub mode select

Interpolation sub mode select is used to select the method of interpolation under IP control.

Pronet servo drive only offers linear interpolation.

Index	60C0h
Name	Interpolation sub mode select
Object Code	VAR
Data Type	INT16
Access	RW
PDO Mapping	NO
Value Range	0
Default Value	0
Comment	0: Linear interpolation

Interpolation data record

Interpolation data record is used to reserve interpolation portion data. Our servo drive's interpolation command only uses the first data whose subindex is 1.

Index	60C1h
Subindex	0
Object Code	ARRAY
Data Type	INT32
Access	RO
PDO Mapping	YES
Value Range	INT8
Default Value	2
Comment	number of entries

Index	60C1h
Subindex	1
Object Code	ARRAY
Data Type	INT32
Access	RW
PDO Mapping	YES
Value Range	INT32
Default Value	0
Comment	the first parameter of ip function

Index	60C1h
Subindex	2
Object Code	ARRAY
Data Type	INT32
Access	RW
PDO Mapping	YES
Value Range	INT32
Default Value	0
Comment	The second parameter of ip function

Interpolation time period

Interpolation time period is used to reserve the time data of interpolation position.

Index	60C2h
Subindex	0
Object Code	RECORD
Data Type	INT8
Access	RO
PDO Mapping	NO
Value Range	2
Default Value	2
Comment	number of entries

Index	60C2h
Subindex	1
Object Code	
Data Type	UINT8
Access	RW
PDO Mapping	YES
Value Range	0~255
Default Value	1
Comment	Interpolation time units

Index	60C2h
Subindex	2
Object Code	
Data Type	INT8
Access	RW
PDO Mapping	YES
Value Range	-4~0
Default Value	-3
Comment	Interpolation time index

5.9 Cyclic synchronous position mode

Cyclic synchronous position mode is similar to position interpolation mode. In this control mode, the master could offer extra speed and torque to achieve speed and torque feed forward control. The interpolation cycle time defines the time for target position updating. In this case, interpolation cycle time is the same as sync time.

Parameters related to CYCLIC SYNCHRONOUS POSITION MODE

Index	Name	Type	Attr.	PDO Mapping	M/O
6040 _h	Controlword	UINT16	RW	YES	M
6041 _h	Statusword	UINT16	RO	YES	M
6064 _h	Position_actual_value	INT32	RO	YES	M
607A _h	target_position	INT32	RW	YES	M
607B _h	Positin_range_limit	INT32	RW	NO	O
6081 _h	profile_velocity	UINT32	RW	YES	M

Index	Name	Type	Attr.	PDO Mapping	M/O
6082 _h	end_velocity	UINT32	RW	YES	O
6083 _h	profile_acceleration	UINT32	RW	YES	O
6084 _h	profile_deceleration	UINT32	RW	YES	O
6085 _h	quick_stop_deceleration	UINT32	RW	YES	O

Chapter 6 EtherCAT communication example

In this example, we use Beckhoff TwinCAT software as the real time master. Please prepare as below before the test:

- 1) Identify the network interface model number and install the network interface correctly.
- 2) Install Beckhoff TwinCAT software.
- 3) Copy the device description document (.XML document) to the directory **C:\TwinCAT\IO\EtherCAT**. (You could contact Estun to have this XML document)
- 4) Set drive's parameter Pn006.0=4, select EtherCAT communication mode, Pn704 is the address.

After finishing copying, reactivate TwinCAT software. Then TwinCAT will list an ESTUN ProNet servo drive EtherCAT bus option.

And then please follow steps as below:

- 1 Use the right button of the mouse to single click **I/O Device** and choose EtherCAT network adapter. Name it as **Device 1**.

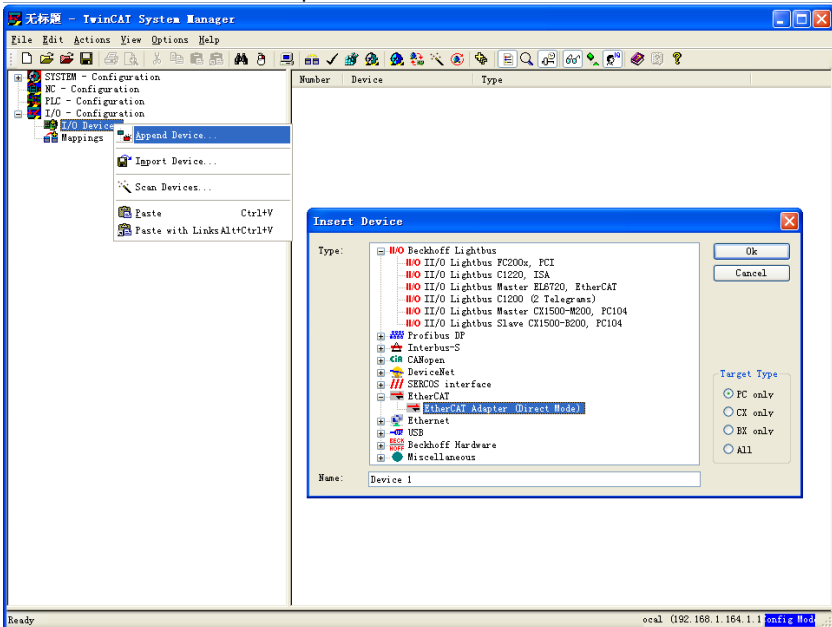

Use the right button of the mouse to single click **Device 1** and add a slave ProNet device.

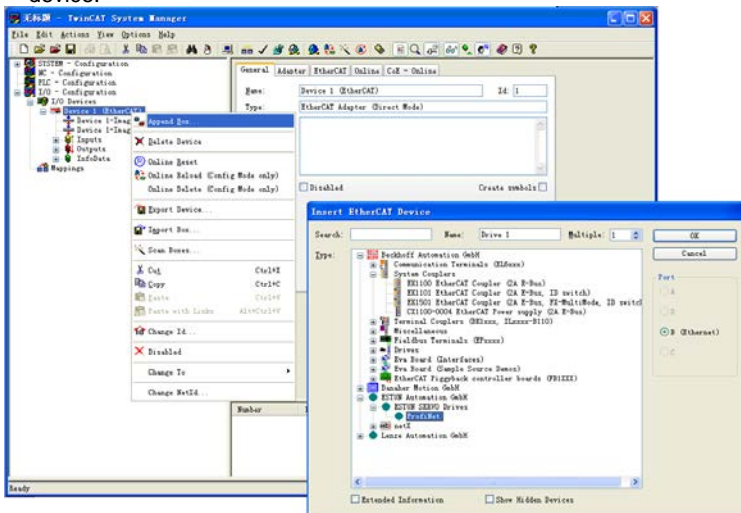

3. Add one NC task and name it as **Task 1**.

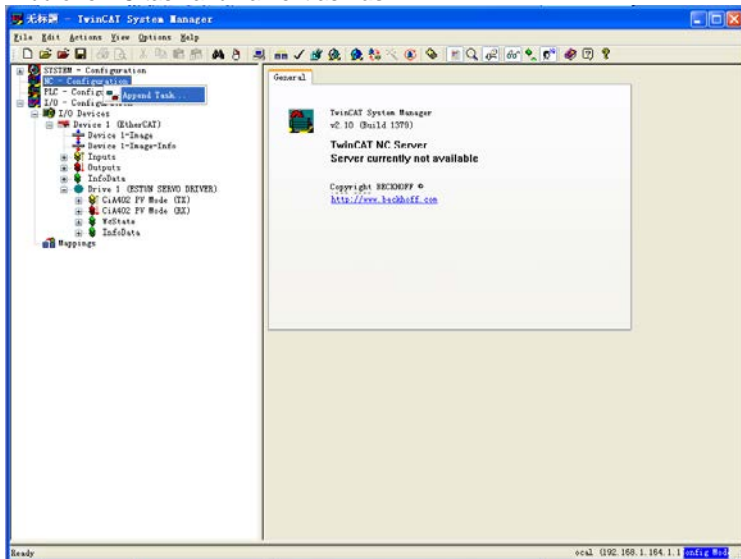

Add **Axis 1** under NC task.

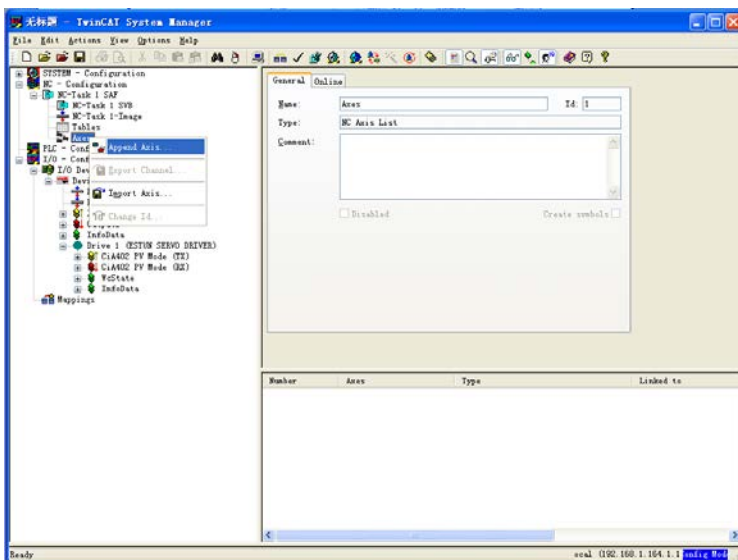

Choose application layer protocol **CoE**.

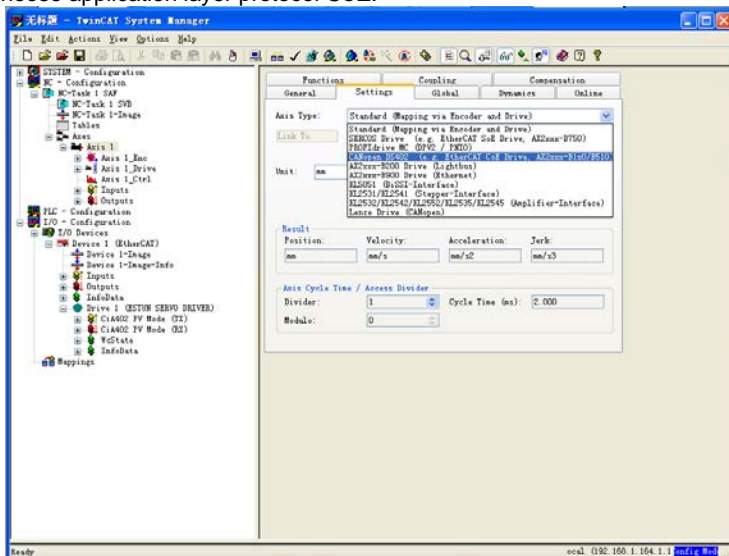

Click **Link to** button and map servo drive axis to the device.

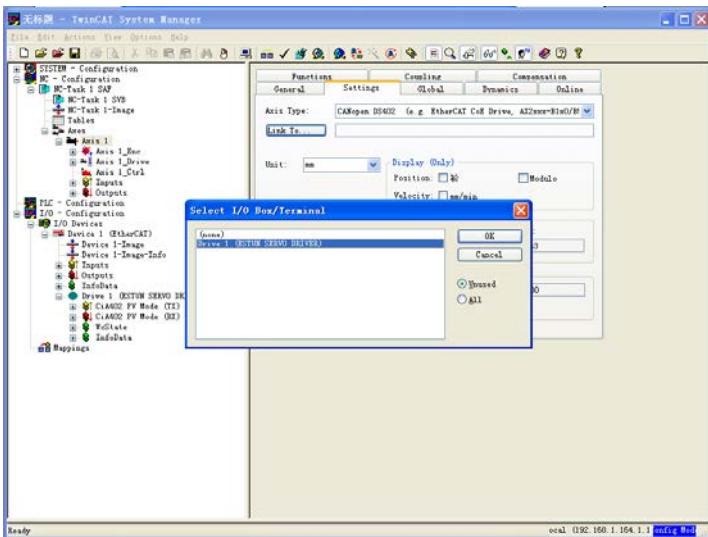

Click **activate configuration** button on the toolbar and activate configuration.
Click **online** label and start to operate on servo axis.

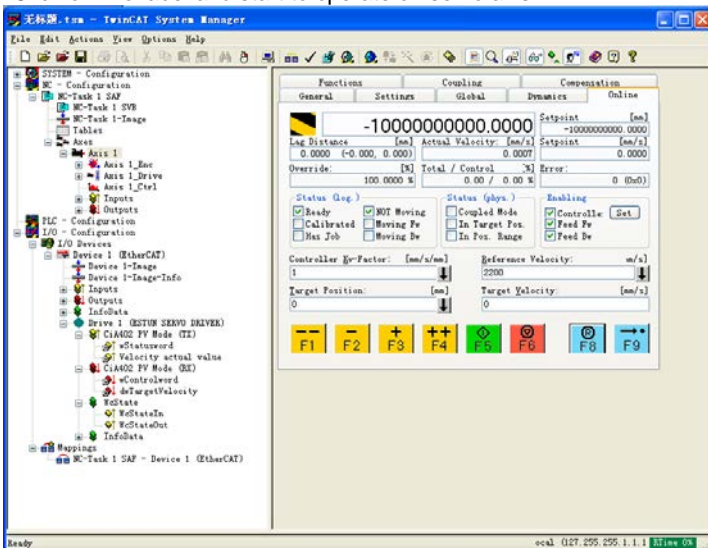

Appendix A Object dictionary

Index	Sub index	Name	Type	Access.	PDO	Support						Unit
						All	PP	PV	HM	IP	CSP	
1000	0	Device type	UINT32	RO	NO	•						
1001	0	Error register	UINT8	RO	NO	•						
1003	Pre-defined error field											
	0	Number of entries	UINT8	RO	NO	•						
	1	Standard error field1	UINT32	RO	NO	•						
	UINT32	RO	NO	•						
	7	Standard error field7	UINT32	RO	NO	•						
	8	Standard error field8	UINT32	RO	NO	•						
1018	Identity Object											
	0	Number of entries	UINT8	RO	NO	•						
	1	Vender ID	UINT32	RO	NO	•						
	2	Product code	UINT32	RO	NO	•						
	3	Revision number	UINT32	RO	NO	•						
	4	Serial number	UINT32	RO	NO	•						

Index	Sub index	Name	Type	Access.	PDO	Support						Unit
						All	PP	PV	HM	IP	CSP	
1600	1st Receive PDO Mapping											
	0	Number of entries	UINT8	RW	NO	•						
	1	Mapping entry 1	UINT32	RW	NO	•						
	2	Mapping entry 2	UINT32	RW	NO	•						
	3	Mapping entry 3	UINT32	RW	NO	•						
	4	Mapping entry 4	UINT32	RW	NO	•						
	5	Mapping entry 5	UINT32	RW	NO	•						
	6	Mapping entry 6	UINT32	RW	NO	•						
	7	Mapping entry7	UINT32	RW	NO	•						
8	Mapping entry 8	UINT32	RW	NO	•							
1601	2nd Receive PDO Mapping											
	0	Number of entries	UINT8	RW	NO	•						
	1	Mapping entry 1	UINT32	RW	NO	•						
	2	Mapping entry 2	UINT32	RW	NO	•						
	3	Mapping entry 3	UINT32	RW	NO	•						
	4	Mapping entry 4	UINT32	RW	NO	•						
	5	Mapping entry 5	UINT32	RW	NO	•						

Index	Sub index	Name	Type	Access.	PDO	Support						Unit
						All	PP	PV	HM	IP	CSP	
	6	Mapping entry 6	UINT32	RW	NO	•						
	7	Mapping entry7	UINT32	RW	NO	•						
	8	Mapping entry 8	UINT32	RW	NO	•						
1602	3rd Receive PDO Mapping											
	0	Number of entries	UINT8	RW	NO	•						
	1	Mapping entry 1	UINT32	RW	NO	•						
	2	Mapping entry 2	UINT32	RW	NO	•						
	3	Mapping entry 3	UINT32	RW	NO	•						
	4	Mapping entry 4	UINT32	RW	NO	•						
	5	Mapping entry 5	UINT32	RW	NO	•						
	6	Mapping entry 6	UINT32	RW	NO	•						
	7	Mapping entry7	UINT32	RW	NO	•						
8	Mapping entry 8	UINT32	RW	NO	•							
1603	4th Receive PDO Mapping											
	0	Number of entries	UINT8	RW	NO	•						
	1	Mapping entry 1	UINT32	RW	NO	•						

Index	Sub index	Name	Type	Access.	PDO	Support						Unit
						All	PP	PV	HM	IP	CSP	
	2	Mapping entry 2	UINT32	RW	NO	•						
	3	Mapping entry 3	UINT32	RW	NO	•						
	4	Mapping entry 4	UINT32	RW	NO	•						
	5	Mapping entry 5	UINT32	RW	NO	•						
	6	Mapping entry 6	UINT32	RW	NO	•						
	7	Mapping entry7	UINT32	RW	NO	•						
	8	Mapping entry 8	UINT32	RW	NO	•						
1A00	1st Receive PDO Mapping											
	0	Number of entries	UINT8	RW	NO	•						
	1	Mapping entry 1	UINT32	RW	NO	•						
	2	Mapping entry 2	UINT32	RW	NO	•						
	3	Mapping entry 3	UINT32	RW	NO	•						
	4	Mapping entry 4	UINT32	RW	NO	•						
	5	Mapping entry 5	UINT32	RW	NO	•						
	6	Mapping entry 6	UINT32	RW	NO	•						
	7	Mapping entry7	UINT32	RW	NO	•						

Index	Sub index	Name	Type	Access.	PDO	Support						Unit
						All	PP	PV	HM	IP	CSP	
	8	Mapping entry 8	UINT32	RW	NO	•						
1A01	2nd Transmit PDO Mapping											
	0	Number of entries	UINT8	RW	NO	•						
	1	Mapping entry 1	UINT32	RW	NO	•						
	2	Mapping entry 2	UINT32	RW	NO	•						
	3	Mapping entry 3	UINT32	RW	NO	•						
	4	Mapping entry 4	UINT32	RW	NO	•						
	5	Mapping entry 5	UINT32	RW	NO	•						
	6	Mapping entry 6	UINT32	RW	NO	•						
	7	Mapping entry 7	UINT32	RW	NO	•						
	8	Mapping entry 8	UINT32	RW	NO	•						
1A02	3rd Transmit PDO Mapping											
	0	Number of entries	UINT8	RW	NO	•						
	1	Mapping entry 1	UINT32	RW	NO	•						
	2	Mapping entry 2	UINT32	RW	NO	•						

Index	Sub index	Name	Type	Access.	PDO	Support						Unit	
						All	PP	PV	HM	IP	CSP		
	3	Mapping entry 3	UINT32	RW	NO	•							
	4	Mapping entry 4	UINT32	RW	NO	•							
	5	Mapping entry 5	UINT32	RW	NO	•							
	6	Mapping entry 6	UINT32	RW	NO	•							
	7	Mapping entry7	UINT32	RW	NO	•							
	8	Mapping entry 8	UINT32	RW	NO	•							
	1A03	4thTransmit PDO Mapping											
		0	Number of entries	UINT8	RW	NO	•						
1		Mapping entry 1	UINT32	RW	NO	•							
2		Mapping entry 2	UINT32	RW	NO	•							
3		Mapping entry 3	UINT32	RW	NO	•							
4		Mapping entry 4	UINT32	RW	NO	•							
5		Mapping entry 5	UINT32	RW	NO	•							
6		Mapping entry 6	UINT32	RW	NO	•							
7		Mapping entry7	UINT32	RW	NO	•							
8	Mapping entry 8	UINT32	RW	NO	•								

Index	Sub index	Name	Type	Access.	PDO	Support						Unit
						All	PP	PV	HM	IP	CSP	
1C00	Sync Manager Communication Type											
	0	Number of used Sync Manager channels	UINT8	RW	NO	•						
	1	Communication type sync manager 0	UINT32	RW	NO	•						
	2	Communication type sync manager 1	UINT32	RW	NO	•						
	3	Communication type sync manager 2	UINT32	RW	NO	•						
	4	Communication type sync manager 3	UINT32	RW	NO	•						
1C12	Sync Manager PDO assignment 2											
	0	Number of assigned PDOs	UINT8	RW	NO	•						
	1	Index of assigned RxPDO 1	UINT16	RW	NO	•						
	2	Index of assigned RxPDO 2	UINT16	RW	NO	•						

Index	Sub index	Name	Type	Access.	PDO	Support						Unit
						All	PP	PV	HM	IP	CSP	
1C13	Sync Manager PDO assignment 3											
	0	Number of assigned PDOs	UINT8	RW	NO	•						
	1	Index of assigned TxPDO 1	UINT16	RW	NO	•						
	2	Index of assigned TxPDO 2	UINT16	RW	NO	•						

Index	Sub index	Name	Type	Access.	PDO	Support						Unit
						All	PP	PV	HM	IP	CSP	
3000	0	Pn000	UINT16	RW	NO	•						
3001	0	Pn001	UINT16	RW	NO	•						
3002	0	Pn002	UINT16	RW	NO	•						
3003	0	Pn003	UINT16	RW	NO	•						
3004	0	Pn004	UINT16	RW	NO	•						
3005	0	Pn005	UINT16	RW	NO	•						
3006	0	Pn006	UINT16	RW	NO	•						
3010	0	Pn100	UINT16	RW	NO	•						
3011	0	Pn101	UINT16	RW	NO	•						
3012	0	Pn102	UINT16	RW	NO	•						
3013	0	Pn103	UINT16	RW	NO	•						
3014	0	Pn104	UINT16	RW	NO	•						
3015	0	Pn105	UINT16	RW	NO	•						
3016	0	Pn106	UINT16	RW	NO	•						
3017	0	Pn107	UINT16	RW	NO	•						
3018	0	Pn108	UINT16	RW	NO	•						
3019	0	Pn109	UINT16	RW	NO	•						

Index	Sub index	Name	Type	Access.	PDO	Support						Unit
						All	PP	PV	HM	IP	CSP	
301A	0	Pn110	UINT16	RW	NO	•						
301B	0	Pn111	UINT16	RW	NO	•						
301C	0	Pn112	UINT16	RW	NO	•						
301D	0	Pn113	UINT16	RW	NO	•						
301E	0	Pn114	UINT16	RW	NO	•						
301F	0	Pn115	UINT16	RW	NO	•						
3020	0	Pn116	UINT16	RW	NO	•						
3021	0	Pn117	UINT16	RW	NO	•						
3022	0	Pn118	UINT16	RW	NO	•						
3023	0	Pn119	UINT16	RW	NO	•						
3024	0	Pn120	UINT16	RW	NO	•						
3025	0	Pn121	UINT16	RW	NO	•						
3026	0	Pn122	UINT16	RW	NO	•						
3027	0	Pn123	UINT16	RW	NO	•						
3028	0	Pn124	UINT16	RW	NO	•						
3029	0	Pn125	UINT16	RW	NO	•						
302A	0	Pn126	UINT16	RW	NO	•						

Index	Sub index	Name	Type	Access.	PDO	Support						Unit
						All	PP	PV	HM	IP	CSP	
302B	0	Pn127	UINT16	RW	NO	•						
302C	0	Pn128	UINT16	RW	NO	•						
302D	0	Pn129	UINT16	RW	NO	•						
302E	0	Pn130	UINT16	RW	NO	•						
302F	0	Pn131	UINT16	RW	NO	•						
3030	0	Pn132	UINT16	RW	NO	•						
306E	0	Pn407	UINT16	RW	NO	•						
306F	0	Pn408	UINT16	RW	NO	•						
3070	0	Pn409	UINT16	RW	NO	•						
3071	0	Pn410	UINT16	RW	NO	•						
3072	0	Pn411	UINT16	RW	NO	•						
3073	0	Pn412	UINT16	RW	NO	•						
3074	0	Pn413	UINT16	RW	NO	•						
3075	0	Pn414	UINT16	RW	NO	•						
307D	0	Pn505	UINT16	RW	NO	•						
307E	0	Pn506	UINT16	RW	NO	•						
307F	0	Pn507	UINT16	RW	NO	•						

Index	Sub index	Name	Type	Access.	PDO	Support						Unit
						All	PP	PV	HM	IP	CSP	
3080	0	Pn508	UINT16	RW	NO	•						
3081	0	Pn509	UINT16	RW	NO	•						
3082	0	Pn510	UINT16	RW	NO	•						
3083	0	Pn511	UINT16	RW	NO	•						
3084	0	Pn512	UINT16	RW	NO	•						
3085	0	Pn513	UINT16	RW	NO	•						
3086	0	Pn514	UINT16	RW	NO	•						
3088	0	Pn516	UINT16	RW	NO	•						
3089	0	Pn517	UINT16	RW	NO	•						
30FC	0	Pn700	UINT16	RW	NO	•						
30FD	0	Pn701	UINT16	RW	NO	•						
3100	0	Pn704	UINT16	RW	NO	•						
3138	0	Pn840	UINT16	RW	NO	•						
6007	0	Abort connection option code	INT16	RW	NO	•						
603F	0	Error code	UINT16	RW	YES	•						
6040	0	Control word	UINT16	RW	YES	•						

Index	Sub index	Name	Type	Access.	PDO	Support						Unit
						All	PP	PV	HM	IP	CSP	
6041	0	Status word	UINT16	RO	YES	•						
605A	0	Quick stop option code	INT16	RW	NO	•						
605B	0	Shutdown option code	INT16	RW	NO	•						
605C	0	Disable operation option code	INT16	RW	NO	•						
605D	0	Stop option code	INT16	RW	NO	•						
605E	0	Fault reaction option code	UINT16	RW	NO	•						
6060	0	Modes of operation	INT8	RW	YES	•						
6061	0	Modes of operation display	INT8	RO	YES	•						
6062	0	Position demand value	INT32	RO	YES		•			•		position units
6063	0	Position actual value*	INT32	RO	YES		•			•		inc
6064	0	Position actual value	INT32	RO	YES		•			•		position units
6065	0	Following error window	UINT32	RW	YES		•					position units
6066	0	Following error time out	UINT16	RW	YES		•					ms
6067	0	Position window	UINT32	RW	YES		•					position units
6068	0	Position window time	UINT16	RW	YES		•					ms

Index	Sub index	Name	Type	Access.	PDO	Support						Unit
						All	PP	PV	HM	IP	CSP	
6069	0	Velocity sensor actual value	UINT16	RW	YES			•				speed units
606B	0	Velocity demand value	INT32	RO	YES			•				speed units
606C	0	Velocity actual value	INT32	RO	YES			•				speed units
606D	0	Velocity window	UINT16	RW	YES			•				speed units
606E	0	Velocity window time	UINT16	RW	YES			•				ms
606F	0	Velocity threshold	UINT16	RW	YES			•				speed units
6070	0	Velocity threshold time	UINT16	RW	YES			•				ms
6077	0	Torque actual value	INT16	RO	YES	•						
6078	0	Current actual value	INT16	RO	YES	•						
607A	0	Target position	INT32	RW	YES		•					position units
607B	Position range limit											
	0	Number of entries	UINT8	RO	NO		•			•	•	
	1	Min position range limit	INT32	RW	NO		•			•	•	position units
	2	Max position range limit	INT32	RW	NO		•			•	•	position units
607C	0	Home offset	INT32	RW	YES		•		•	•	•	position units
607D	Software Position Limit											
	0	Number of entries	UINT8	RO	NO		•			•	•	

Index	Sub index	Name	Type	Access.	PDO	Support						Unit
						All	PP	PV	HM	IP	CSP	
	1	Min position limit	INT32	RW	NO		•			•	•	position units
	2	Max position limit	INT32	RW	NO		•			•	•	position units
607E	0	Polarity	USINT	RW	NO	•						
6081	0	Profile velocity	UINT32	RW	YES		•					speed units
6082	0	End velocity	UINT32	RW	YES		•					speed units
6083	0	Profile acceleration	UINT32	RW	YES		•	•				acceleration units
6084	0	Profile deceleration	UINT32	RW	YES		•	•		•		acceleration units
6085	0	Quick stop deceleration	UINT32	RW	YES		•	•		•		acceleration units
6086	0	Motion profile type	INT16	RO	YES		•	•		•		
6093	Position factor											
	0	Number of entries	UINT32	RW	NO		•		•	•		
	1	numerator	UINT32	RW	NO		•		•	•		
	2	divisor	UINT32	RW	NO		•		•	•		
6094	--	Velocity encoder factor	--	--	--	•						
	0	Number of entries	UINT32	RW	NO	•						
	1	numerator	UINT32	RW	NO	•						
	2	divisor	UINT32	RW	NO	•						
6097	Acceleration factor											

Index	Sub index	Name	Type	Access.	PDO	Support						Unit
						All	PP	PV	HM	IP	CSP	
	0	Number of entries	UINT32	RW	NO	•						
	1	numerator	UINT32	RW	NO	•						
6098	0	Homing method	INT8	RW	YES				•			
6099	Homing speeds											
	0	Number of entries	UINT8	RW	YES				•			
	1	Speed during search for switch	UINT32	RW	YES				•			speed units
	2	Speed during search for zero	UINT32	RW	YES				•			speed units
609A	0	Homing acceleration	UINT32	RW	YES				•			acceleration units
60B1	0	Velocity Offset	INT32	RW	YES						•	
60B2	0	Torque Offset	INT	RW	YES						•	
60C1	Interpolation data record											
	0	Number of entries	UINT8	RO	NO					•		
	1	1st set-point	INT32	RW	YES					•		position units
60C2	Interpolation time period											
	0	Number of entries	UINT8	RO	NO					•		
	1	Interpolation time period value	UINT8	RW	NO					•		

Index	Sub index	Name	Type	Access.	PDO	Support						Unit
						All	PP	PV	HM	IP	CSP	
	2	Interpolation time index	UINT16	RW	NO					•		
60FA	0	Control effort	INT32	RO	YES		•			•		
60FC	0	Position demand value	INT32	RO	YES		•			•	•	position units
60FD	0	Digital inputs	UINT32	RO	YES	•						
60FE	Digital outputs											
	0	Number of entries	UINT8	RO	NO	•						
	1	Physical outputs	UINT32	RW	YES	•						
	2	Bit mask	UINT32	RW	YES	•						
60FF	0	Target velocity	INT32	RW	YES		•					0.1rpm
60A4	Profile jerk											
	0	Number of entries	UINT8	RO	NO		•					
	1	Profile jerk 1	UINT32	RW	NO		•					acceleration units
6502	0	Supported drive modes	UINT32	RO	NO	•						

Appendix B Parameters

B.1 Parameter list

Parameter No.	Description	Unit	Range	Default	Setting invalidation
Pn000	Binary Pn000.0: Servo ON Pn000.1: Forward rotation input signal prohibited (P-OT) Pn000.2: Reverse rotation input signal prohibited (N-OT) Pn000.3: Alarm output when instantaneous power loss	—	0~1111	0	After restart
Pn001	Binary Pn001.0: CCW,CW selection	—	0~1111	0	After restart
Pn003	Binary Pn003.0: Reserved Pn003.1: Reserved Pn003.2: Low speed compensation Pn003.3: Overload enhancement	—	0~1111	0	After restart
Pn004	Hex Pn004.0: Stop mode Pn004.1: Error counter clear mode	—	0~0x3425	0	After restart
Pn005	Hex Pn005.2: Out-of-tolerance alarm selection Pn005.3: Servomotor model	—	0~0x33E3	0	After restart
Pn006	Hex Pn006.0: Bus mode Pn006.1: Reserved	—	0~0x2133	0x0020	After restart

Parameter No.	Description	Unit	Range	Default	Setting invalidation
	Pn006.2: Low frequency jitter suppression switch				
Pn100	Online autotuning setting 0:Manual gain adjustment 1,2,3=Normal mode;4,5,6=Vertical load 1,4 = Load inertia without variation; 2,5 = Load inertia with little variation; 3,6= Load inertia with great variation	—	0~6	1	After restart
Pn101	Machine rigidity setting	—	0~15	5	Immediately
Pn102	Speed loop gain	Hz	1~4000	160	Immediately
Pn103	Speed loop integral time constant	0.1ms	1~4096	200	Immediately
Pn104	Position loop gain	1/s	0~1000	40	Immediately
Pn105	Torque reference filter time constant	0.1ms	0~250	4	Immediately
Pn106	Load inertia percentage	—	0~20000	0	Immediately
Pn107	2nd speed loop gain	Hz	1~4000	40	Immediately
Pn108	2nd speed loop integral time constant	0.1ms	1~4096	200	Immediately
Pn109	2nd position loop gain	Hz	0~1000	40	Immediately
Pn110	2nd torque reference filter time constant	0.1ms	0~250	4	Immediately
Pn111	Speed bias	rpm	0~300	0	Immediately
Pn112	Feedforward	%	0~100	0	Immediately
Pn113	Feedforward filter	0.1ms	0~640	0	Immediately
Pn114	Torque feedforward	%	0~100	0	Immediately
Pn115	Torque feedforward filter	0.1ms	0~640	0	Immediately
Pn116	P/PI switching condition 0: Torque reference percentage	—	0~4	0	After restart

Parameter No.	Description	Unit	Range	Default	Setting invalidation
	1: Value of offset counter 2: Value of acceleration speed setting 3: Value of speed setting 4: Fixed PI				
Pn117	Torque switching threshold	%	0~300	200	Immediately
Pn118	Offset counter switching threshold	reference pulse	0~10000	0	Immediately
Pn119	Setting acceleration speed switching threshold	10rpm/s	0~3000	0	Immediately
Pn120	Setting speed switching threshold	rpm	0~10000	0	Immediately
Pn121	Gain switching condition 0: Fix to 1st group gain 1: External switch gain switching 2: Torque percentage 3: Value of offset counter 4: Value of acceleration speed setting 5: Value of speed setting 6: Speed reference input 7: actual motor speed	—	0~6	0	After start
Pn122	Switching delay time	0.1ms	0~20000	0	Immediately
Pn123	Threshold switching level		0~20000	0	Immediately
Pn124	Reserved	—	—	—	—
Pn125	Position gain switching time	0.1ms	0~20000	0	Immediately
Pn126	Hysteresis switching	—	0~20000	0	Immediately
Pn127	Low speed detection filter	0.1ms	0~100	10	Immediately
Pn128	Speed gain acceleration relationship during online autotuning	—	0~3	3	Immediately

Parameter No.	Description	Unit	Range	Default	Setting invalidation
Pn129	Low speed correction coefficient	—	0~30000	0	Immediately
Pn130	Friction load	0.1%	0~3000	0	Immediately
Pn131	Friction compensation speed hysteresis area	rpm	0~100	0	Immediately
Pn132	Sticking friction load	0.1%/1000rpm	0~1000	0	Immediately
Pn133	Reserved	—	—	—	—
Pn134	Reserved	—	—	—	—
Pn135	Reserved	—	—	—	—
Pn136	Reserved	—	—	—	—
Pn137	Reserved	—	—	—	—
Pn138	Reserved	—	—	—	—
Pn139	Reserved	—	—	—	—
Pn140	Reserved	—	—	—	—
Pn141	Reserved	—	—	—	—
Pn142	Reserved	—	—	—	—
Pn143	Reserved	—	—	—	—
Pn144	Reserved	—	—	—	—
Pn304	Parameter speed	rpm	-6000~6000	500	Immediately
Pn305	JOG speed	rpm	0~6000	500	Immediately
Pn306	Soft start acceleration time	ms	0~10000	0	Immediately
Pn307	Soft start deceleration time	ms	0~10000	0	Immediately
Pn308	Speed filter time constant	ms	0~10000	0	Immediately
Pn309	S curve risetime	ms	0~10000	0	Immediately
Pn310	Speed reference curve form 0:Slope	—	0~3	0	After restart

Parameter No.	Description	Unit	Range	Default	Setting invalidation
	1:S curve 2:1 st order filter 3:2 nd order filter				
Pn311	S form selection	—	0~3	0	Immediately
Pn407	Notch filter 1 frequency	Hz	50~5000	5000	Immediately
Pn408	Notch filter 1 depth	—	0~11	1	Immediately
Pn409	Notch filter 2 frequency	Hz	50~5000	5000	Immediately
Pn410	Notch filter 2 depth	—	0~11	1	Immediately
Pn411	Low frequency jitter frequency	0.1Hz	50~500	100	Immediately
Pn412	Low frequency jitter damp	—	0~200	25	Immediately
Pn500	Positioning error	Puls	0~5000	10	Immediately
Pn501	Coincidence difference	rpm	0~100	10	Immediately
Pn502	Zero clamp speed	rpm	0~3000	10	Immediately
Pn503	Rotation detection speed TGON	rpm	0~3000	20	Immediately
Pn504	Offset counter overflow alarm	256Puls	1~32767	1024	Immediately
Pn505	Servo ON waiting time	ms	-2000~2000	0	Immediately
Pn506	Basic waiting flow	10ms	0~500	0	Immediately
Pn507	Brake waiting speed	rpm	10~100	100	Immediately
Pn508	Brake waiting time	10ms	10~100	50	Immediately
Pn509	Allocate input signal to terminal	—	0~0xFFFF	0x3210	After restart
Pn510	Allocate input signal to terminal	—	0~0xFFFF	0x7654	After restart
Pn511	Allocate output signal to terminal	—	0~0x0999	0x0210	After restart
Pn512	Bus control input node low-bit enable	—	0~1111	0	Immediately
Pn513	Bus control input node low-bit enable	—	0~1111	0	Immediately

Parameter No.	Description	Unit	Range	Default	Setting invalidation
Pn514	Input port filter	0.2ms	0~1000	1	Immediately
Pn515	Alarm port filter	0.2ms	0~3	1	Immediately
Pn516	Input port signal inversion	—	0~1111	0	Immediately
Pn517	Input port signal inversion	—	0~1111	0	Immediately
Pn518	Dynamic brake time	0.5ms	50~2000	125	Immediately
Pn519	Serial encoder error time	0.1ms	0~10000	3	Immediately
Pn520	Position complete time	0.1ms	0~60000	500	Immediately
Pn521	If connect externally regenerative resistor 0: connect externally regenerative resistor between B1 and B2 1: dose not connect externally regenerative resistor, relay on internal capacitance (This parameter is in effect only on ProNet-02/04 /ProNet-E-02/04)	—	0~1	1	Immediately
Pn522	Reserved	—	—	—	—
Pn523	Reserved	—	—	—	—
Pn524	Reserved	—	—	—	—
Pn525	Overload alarm threshold	%	100~150	100	Immediately
Pn526	Temperature threshold of motor overheat alarm (Only enabled in ProNet-75/1A/1E/2B)	℃	50~180	110	Immediately
Pn528	Output signal inverse	—	0~1111	0	Immediately
Pn529	Torque detection output signal threshold value	%	3~300	100	Immediately
Pn530	Torque detection output signal time	ms	1~1000	10	After restart
Pn700	Hex Pn700.0: MODBUS communication baud rate	—	0~0x0182	0x0151	After restart

Parameter No.	Description	Unit	Range	Default	Setting invalidation
	Pn700.1: MODBUS protocol selection Pn700.2: Communication protocol selection Pn700.3: Reserved				
Pn701	MODBUS axis address	—	1~247	1	After restart
Pn702	Reserved	—	—	—	—
Pn703	EtherCAT communication speed	—	0x0005	0x0004	After restart
Pn704	EtherCAT communication contact	—	1~127	1	After restart
Pn840	Hex Pn840.0: Encoder model selection Pn840.1: Reserved Pn840.2: Reserved Pn840.3: Reserved	—	0x0003~ 0x0B06	—	After restart

B.2 Parameters in detail

Parameter No.	Description	Setting Validation	Control Mode	Function and Meaning
Pn000	Binary	After restart	ALL	<p>Pn000.0 Servo ON [0] External S-ON enabled. [1] External S-ON disabled. Servo motor excitation signal is turned ON automatically after S-RDY is output.</p> <p>Pn000.1 Forward rotation input signal prohibited (P-OT) [0] External P-OT enabled. Operate in the time sequence setting in Pn004.0 when travel limit occurs. [1] External P-OT disabled.</p> <p>Pn000.2 Reverse rotation input signal prohibited (N-OT) [0] External N-OT enabled. Operate in the time sequence setting in Pn004.0 when travel limit occurs. [1] External N-OT disabled.</p> <p>Pn000.3 Alarm output when instantaneous power loss [0] Instantaneous power loss for one period with no alarm output [1] Instantaneous power loss for one period with alarm output</p>
Pn001	Binary	After restart	Pn001.0 ALL Pn001.1 T Pn001.2 P, S Pn001.3 P	<p>Pn001.0 CCW,CW selection [0] Sets CCW as forward direction [1] Sets CW as forward direction</p>

Pn003	Binary	After restart	ALL	<p>Pn003.0 Reserved</p> <p>Pn003.1 Reserved</p> <p>Pn003.2 Low speed compensation [0] Without low speed correction [1] With low speed correction to avoid servomotor creeping, but the degree of correction is determined by the setting in Pn219.</p> <p>Pn003.3 Overload enhancement [0] Without overload enhancement function [1] With overload enhancement function, which can enhance the overload capacity when servomotor exceeds the 2 times rated overload. It is used in frequent power ON/OFF occasions.</p>
Pn004	Hex	After restart	Pn004.0 ALL Pn004.1 P Pn004.2 P Pn004.3 P	<p>Pn004.0 Stop Mode [0] Stops the servomotor by applying DB and then releases DB. [1] Coast to a stop. [2] Stops the servomotor by DB when servo OFF, stops the servomotor by plug braking when overtravel, then places it into coast (power OFF) mode. [3] Makes the servomotor coast to a stop state when servo OFF, stops the servomotor by plug braking when overtravel, then places it into coast (power OFF) mode. [4] Stops the servomotor by DB when servo OFF, stops the servomotor by plug braking when overtravel, then places it into zero clamp mode. [5] Makes the servomotor coast to a stop state when servo OFF, stops the servomotor by plug braking when overtravel, then places it into zero clamp mode.</p> <p>Pn004.1 Error counter clear mode [0] Clear error pulse when S-OFF, do not when overtravel. [1] Do not clear error pulse. [2] Clear error pulse when S-OFF overtravel (except for zero clamp)</p>

Pn005	Hex	After restart	<p>Pn005.0 P, S Pn005.1 ALL Pn005.2 P</p>	<p>Pn005.2 Out-of-tolerance alarm selection [0] Out-of-tolerance alarm disabled [1] Out-of-tolerance alarm enabled. Outputs alarm when the value of error counter exceeds Pn504 setting value. [2] Reserved [3] Reserved</p> <p>Pn005.3 Servomotor model selection① [0] EMJ [1] EMG [2] Reserved [3] EMB</p>
Pn006	Hex	After restart		<p>Pn006.0 Bus type selection [0] ~ [3] No bus [4] EtherCAT</p> <p>Pn006.1 Reserved</p> <p>Pn006.2 Low-frequency vibration suppression switch [0] Low-frequency vibration suppression function disabled [1] Low-frequency vibration suppression function enabled</p>

Pn100	Online autotuning setting	After restart	P, S	<p>[0] Manual gain adjustment [1,2,3] Normal mode [4,5,6] Vertical load [1,4] Load inertia without variation [2,5] Load inertia with little variation [3,6] Load inertia with great variation</p> <p>Note:</p> <ol style="list-style-type: none"> 1.Autotuning is invalid when servomotor max.speed is less than 100rpm. Manual gain adjustment is used. 2.Autotuning is invalid when servomotor acceleration/deceleration speed is less than 5000rpm/s. Manual gain adjustment is used. 3.Autotuning is invalid when mechanical clearance is too big during operation. Manual gain adjustment is used. 4.Autotuning is invalid when the difference of different speed load is too great. Manual gain adjustment is used.
Pn101	Machine rigidity setting	Immediately	P, S	The response speed of servo system is determined by this parameter. Normally, the rigidity should be set a little larger. However, if it is too large, it would suffer mechanical impact. It should be set a little smaller when large vibration is present. This parameter is only valid in autotuning.
Pn102	Speed loop gain	Immediately	P, S	This parameter determines speed loop gain. Unit: Hz
Pn103	Speed loop integral time constant	Immediately	P, S	Decreases the value of this parameter to shorten positioning time and enhance speed response. Unit: 0.1ms

Pn104	Position loop gain	Immediately	P	This parameter determines position loop gain. Decreases this value to enhance servo rigidity, but vibration will occur if the value is too large. Unit: 1/s
Pn105	Torque reference filter time constant	Immediately	P, S, T	Torque reference filter can eliminate or lighten mechanical vibration, but incorrect setting will result to mechanical vibration. Unit:0.1ms
Pn106	Load inertia percentage	Immediately	P, S	Setting value=(load inertia/rotor inertia) × 100 Unit: %
Pn107	2nd speed loop gain	Immediately	P, S	The meanings of these parameters are the same as Pn102~Pn105. These parameters are only needed to set when two types of gain function are enabled.
Pn108	2nd speed loop integral time constant	Immediately	P, S	
Pn109	2nd position loop gain	Immediately	P	
Pn110	2nd torque reference filter time constant	Immediately	P, S, T	

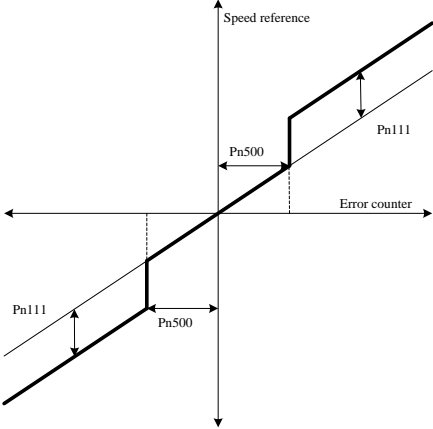
Pn111	Speed bias	Immediately	P	<p>This parameter setting can shorten positioning time. However, if it is too large or does not cooperate with Pn111 correctly, vibration will occur.</p> <p>The relationship with speed reference, error counter, positioning error is shown in the following chart.</p> 
Pn112	Feedforward	Immediately	P	<p>It is used to set position feedforward. The response speed is faster and position error is less when this parameter setting is higher. Vibration will occur if the value is set too large.</p> <p>Unit: %</p>
Pn113	Feedforward filter	Immediately	P	<p>It is used to ease mechanical vibration due to position feedforward. The feedforward lag will be enlarged and result to vibration if the value is set too large.</p> <p>Unit: 0.1ms</p>

Pn114	Torque feedforward	Immediately	P, S	It is used to set torque feedforward, and enhance response speed. Set the load inertia percentage(Pn106) correctly to enable this function in manual gain adjustment mode. Unit: %
Pn115	Torque feedforward filter	Immediately	P, S	It is used to ease mechanical vibration due to torque feedforward. Unit: 0.1ms
Pn116	P/PI switching condition	After restart	P, S	0: Torque reference percentage 1: Value of offset counter 2: Value of acceleration speed setting 3: Value of speed setting 4: Fixed PI
Pn117	Torque switching threshold	After restart	P, S	Threshold of torque to switch PI control to P control. Unit: %
Pn118	Offset counter switching threshold	Immediately	P	Threshold of error counter to switch PI control to P control. Unit: pulse
Pn119	Setting acceleration speed switching threshold	Immediately	P, S	Threshold of acceleration speed to switch PI control to P control. Unit: 10rpm/s
Pn120	Setting speed switching threshold	Immediately	P, S	Threshold of speed to switch PI control to P control. Unit: rpm

Pn121	Gain switching condition	After restart	P, S	0: Fix to 1st group gain 1: External switch gain switching(G-SEL) 2: Torque percentage 3: Value of offset counter 4: Value of acceleration speed setting (10rpm) 5: Value of speed setting 6: Speed reference input 7: actual motor speed
Pn122	Switching delay time	Immediately	P, S	Delay time of switching gain when switching condition is satisfied.
Pn123	Switch threshold level	Immediately	P, S	Gain switching trigger level
Pn124	Reserved	—	—	—
Pn125	Position gain switching time	Immediately	P	This parameter is used to smooth transition if the change of the two groups of gain is too large.
Pn126	Hysteresis switching	Immediately	P, S	This parameter is used to set the operation hysteresis of gain switching.
Pn127	Low speed detection filter	Immediately	P, S	This parameter is used to filter in low speed detection. The speed detection will be lagged if the value is too large.
Pn128	Speed gain acceleration relationship during online autotuning	Immediately	P, S	The increasing multiple of speed loop gain is the same rigidity during online autotuning. The speed loop gain is larger when this value is higher.

Pn129	Low speed correction coefficient	Immediately	P, S	The intensity of anti-friction and anti-creeping at low speed. Vibration will occur if this value is set too large.
Pn130	Friction Load	Immediately	P, S	Friction load or fixed load compensation
Pn131	Friction compensation speed hysteresis area	Immediately	P, S	Threshold of friction compensation start
Pn132	Sticking friction load	Immediately	P, S	Sticking damp which is in direct proportion to speed.
Pn133	Reserved	—	—	—
Pn134	Reserved	—	—	—
Pn135	Reserved	—	—	—
Pn136	Reserved	—	—	—
Pn137	Reserved	—	—	—
Pn138	Reserved	—	—	—
Pn139	Reserved	—	—	—
Pn140	Reserved	—	—	—
Pn141	Reserved	—	—	—
Pn142	Reserved	—	—	—
Pn143	Reserved	—	—	—
Pn144	Reserved	—	—	—
Pn304	Parameter speed	Immediately	S	The parameter can be set to positive or negative. When control mode is set to D, it determines the speed of motor . The servomotor speed is determined by this parameter when Pn005.1=D.

Pn305	JOG speed	Immediately	S	It is used to set JOG rotation speed, and the direction is determined by the pressing key during JOG operation.	
Pn306	Soft start acceleration time	Immediately	S	The time for trapeziform acceleration to accelerate to 1000rpm. Unit: ms	
Pn307	Soft start deceleration time	Immediately	S	The time for trapeziform deceleration to decelerate to 1000rpm. Unit: ms	
Pn308	Speed filter time constant	Immediately	S	1st order filter time constant Unit: ms	
Pn309	S curve risetime	Immediately	S	The time for transition from one point to another point in S curve.	
Pn310	Speed reference curve form	After restart	S	0:Slope 1:S curve 2:1 st order filter 3:2 nd order filter	
Pn311	S form selection	After restart	S	This value determines the transition form of S curve.	
Pn407	Notch filter 1 frequency	Immediately	P, S, T	Notch filter 1 frequency	1. In some conditions, vibration will be picked up and response will be lagged after notch filter is set. 2. When notch filter frequency is set to 5000, the notch filter is invalid.
Pn408	Notch filter 1 depth	Immediately	P, S, T	Notch filter 1 depth	
Pn409	Notch filter 2 frequency	Immediately	P, S, T	Notch filter 2 frequency	

Pn410	Notch filter 2 depth	Immediately	P, S, T	Notch filter 2 depth	
Pn411	Low frequency vibration frequency	Immediately	P, S	Frequency of low frequency vibration with load.	
Pn412	Low frequency vibration damp	Immediately	P, S	Attenuation damp of low frequency vibration with load. It does not need to change.	
Pn500	Positioning error	Immediately	P	Outputs /COIN signal when error counter is less than this value.	
Pn501	Coincidence difference	Immediately	P	Outputs /VCMF signal when the difference between speed reference value and speed feedback value is less than this value.	
Pn502	Zero clamp speed	Immediately	S	The servomotor is locked in the form of temporary position loop when the speed corresponding to the analog input is less than this value.	
Pn503	Rotation detection speed TGON	Immediately	P, S, T	When the servomotor speed exceeds this parameter setting value, it means that the servomotor has already rotated steadily and outputs /TGON signal.	
Pn504	Offset counter overflow alarm	Immediately	P	When the value in error counter exceeds this parameter setting value, it means that error counter alarm has occurred and outputs alarm an signal.	
Pn505	Servo ON waiting time	Immediately	P, S, T	These parameters are only enabled when the port output parameters are allocated with /BK signal output.	
Pn506	Basic waiting flow	Immediately	P, S, T	These parameters are used to keep braking (prevent from gravity glissade or continuous outside force on servomotor) time sequence.	
Pn507	Brake waiting speed	Immediately	P, S, T	Servo ON waiting time: ‡For the parameter is plus,/BK signal is output firstly when servo-ON signal is input,	

Pn508	Brake waiting time	Immediately	P, S, T	<p>and then servomotor excitation signal is created after delaying the parameter setting time.</p> <p>②For the parameter is minus, servomotor excitation signal is output firstly when servo-ON signal is input, and then /BK signal is created after delaying the parameter setting time.</p> <p>Basic waiting flow:</p> <p>Standard setting: /BK output (braking action) and servo-OFF are at the same time. Now, the machine movable part may shift slightly due to gravity according to mechanical configuration and character; it can be eliminated by using the parameters when the servomotor is at stop or at a low speed.</p> <p>Brake waiting speed:</p> <p>/BK signal is output when the servomotor speed is decreased below the parameter setting value at servo-OFF.</p> <p>Brake waiting time:</p> <p>BK signal is output when the delay time exceeds the parameter setting value after servo-OFF.</p> <p>/BK signal is output as long as either of the brake waiting speed or brake waiting time is satisfied.</p>
Pn509	Allocate input port to signal, one port with four bits(hex)	After restart	P, S, T	<p>Pn509.0 corresponding port CN1_14</p> <p>Pn509.1 corresponding port CN1_15</p> <p>Pn509.2 corresponding port CN1_16</p> <p>Pn509.3 corresponding port CN1_17</p>

<p>Pn510</p>	<p>Allocate input port to signal, one port with four bits(hex)</p>	<p>After restart</p>	<p>P, S, T</p>	<p>Pn510.0 corresponding port CN1_39 Pn510.1 corresponding port CN1_40 Pn510.2 corresponding port CN1_41 Pn510.3 corresponding port CN1_42 Terminal PRI: CN1_14< CN1_15< CN1_16< CN1_17< CN1_39< CN1_40< CN1_41< CN1_42 Corresponding signal of each data is shown as following: 0: S-ON 1: P-CON 2: Reserved 3: Reserved 4: ALMRST 5: CLR 6: Reserved 7: Reserved 8: Reserved 9: Reserved A: Reserved B: Reserved C: HmRef D: Reserved E: Reserved</p>
--------------	--	----------------------	----------------	--

Pn511	Output signal allocation	After restart	P, S, T	<p>Pn511.0 corresponding port CN1_11, CN1_12 Pn511.1 corresponding port CN1_05, CN1_06 Pn511.2 corresponding port CN1_09, CN1_10 Corresponding signal of each data is shown as follows: 0: /COIN/CMP 1: /TGON 2: /S-RDY 3: /CLT 4: /BK 5: Reserved 6: Reserved 7: Reserved 8: /HOME 9: Reserved</p>
Pn512	Bus control input node low-bit enabled	Immediately	P, S, T	<p>Bus communication input port enabled: [0]: Disabled [1]: Enabled</p>
Pn513	Bus control input node low-bit enabled	Immediately	P, S, T	<p>Pn512.0→CN1_14 Pn512.1→CN1_15 Pn512.2→CN1_16 Pn512.3→CN1_17 Pn513.0→CN1_39 Pn513.1→CN1_40 Pn513.2→CN1_41 Pn513.3→CN1_42</p>

Pn514	Input port filter	Immediately	P, S, T	It is used to set input port filter time. The signal will be lagged if the parameter setting is too high.
Pn515	Reserved	—	—	—
Pn516	Input port signal inversion	Immediately	P, S, T	[0]: Do not inverse signal. [1]: Inverse signal
Pn517	Input port signal inversion	Immediately	P, S, T	Pn516.0→CN1_14 inversion Pn516.1→CN1_15 inversion Pn516.2→CN1_16 inversion Pn516.3→CN1_17 inversion Pn517.0→CN1_39 inversion Pn517.1→CN1_40 inversion Pn517.2→CN1_41 inversion Pn517.3→CN1_42 inversion
Pn518	Reserved	—	—	—
Pn519	Reserved	—	—	—
Pn520	Reserved	—	—	—
Pn521	Binary	Immediately	P,S,T	If a regenerative resistor is connected externally 0: connect externally regenerative resistor between B1 and B2 1: Do not connect externally regenerative resistor, rely on internal capacitance. (This parameter is in effect only on ProNet-02/04/ ProNet-E-02/04)
Pn522	Reserved	—	—	—
Pn523	Reserved	—	—	—
Pn524	Reserved	—	—	—
Pn525	Overload alarm threshold	Immediately	P, S, T	When load percentage is larger than overload alarm threshold, A04 will occur soon. Pn525 is recommended to set below 120, otherwise the servo drive and motor will be damaged.

Pn526	Temperature threshold of motor overheat alarm (Only enabled in ProNet-75/1A/1E/2B)	Immediately	P, S, T	When servomotor winding temperature exceeds Pn526 setting, A19 will occur. (Only enabled in ProNet-75/1A/1E/2B)
Pn528	Output signal inverse	Immediately	P, S, T	[0]: Do not inverse signal. [1]: Inverse signal Pn528.0→CN1_5,6 inversion Pn528.0→CN1_7,8 inversion Pn528.0→CN1_9,10 inversion Pn528.0→CN1_11,12 inversion
Pn529	Torque detection output signal threshold value	Immediately	P, S, T	When motor torque output is higher than Pn529 setting value, /TCR is ON. When motor torque output is lower than Pn529 setting value, /TCR is OFF. Unit:%
Pn530	Torque detection output signal time	After restart	P, S, T	Torque detection output signal time. Unit: ms

Pn700	Hex	After restart	ALL	<p>Pn700.0 MODBUS communication baud rate</p> <p>[0] 4800bps [1] 9600bps [2] 19200bps</p> <p>Pn700.1 MODBUS protocol selection</p> <p>[0] 7, N, 2 (MODBUS,ASCII) [1] 7, E, 1 (MODBUS,ASCII) [2] 7, O, 1 (MODBUS,ASCII) [3] 8, N, 2 (MODBUS,ASCII) [4] 8, E, 1 (MODBUS,ASCII) [5] 8, O, 1 (MODBUS,ASCII) [6] 8, N, 2 (MODBUS,RTU) [7] 8, E, 1 (MODBUS,RTU) [8] 8, O, 1 (MODBUS,RTU)</p> <p>Pn700.2 Communication protocol selection</p> <p>[0] No protocol SCI communication [1] MODBUS SCI communication</p> <p>Pn700.3 Reserved</p>
Pn701	MODBUS Axis address	After restart	ALL	Axis address of MODBUS protocol communication
Pn702	Reserved	—	—	—

Pn703	EtherCAT communication speed	After restart	ALL	Pn703.0 EtherCAT communication baud rate [0] 50Kbps [1] 100Kbps [2] 125Kbps [3] 250Kbps [4] 500Kbps [5] 1Mbps
Pn704	EtherCAT communication contact	After restart	ALL	EtherCAT Aix address of communication
Pn840	Hex	After restart	ALL	Pn840.0 Encoder model selection [0]-[2] Reserved (For factory using) [3] 17-bit absolute encoder [4] Reserved [5] Resolved [6] Reserved Pn840.1 Reserved (For factory using) Pn840.2 Reserved (For factory using) Pn840.3 Reserved (For factory using)

Note

①: When connecting to EMJ-04A□H□□, Pn005.3 should be set as "1".

②: "the max value of servo receiving pulse frequency" ,it means the sufficient max value of pulse frequency receiving by servo hardware.

Appendix C Standard Wiring Examples

C.1 Single-phase 200VAC (ProNet-02AEA-EC to ProNet-04AEA-EC)

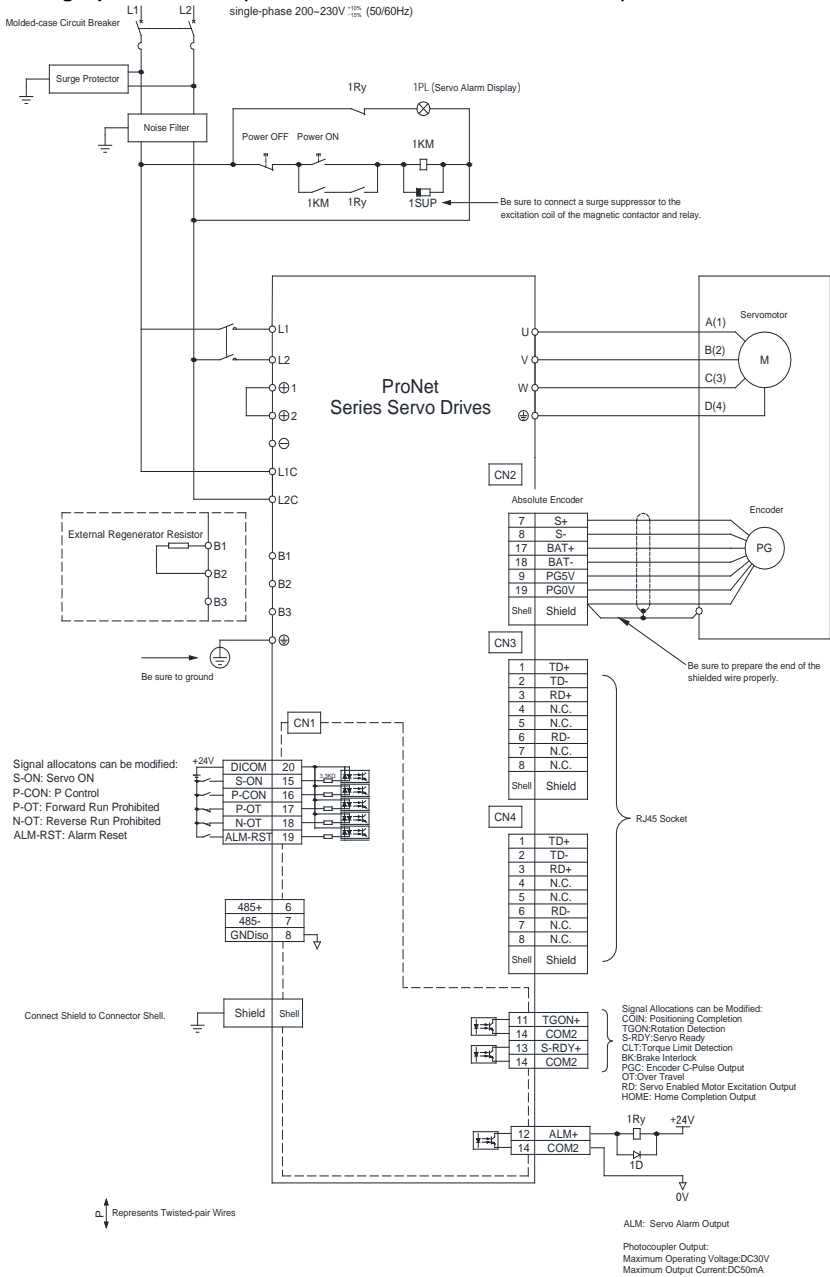

C.2 Three-phase 200VAC (ProNet-08AEA-EC to ProNet-50AEA-EC)

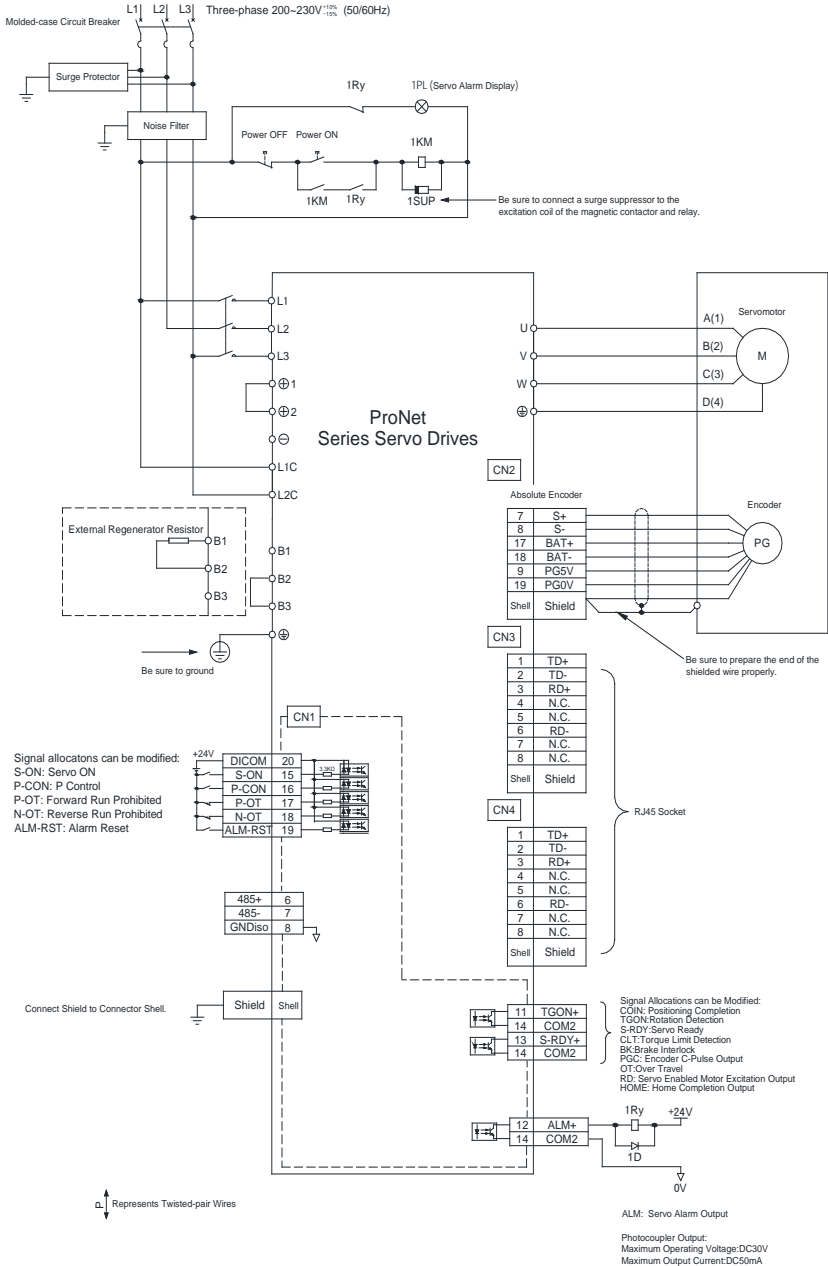

C.3 Three-phase 400VAC (ProNet-10DEA-EC to ProNet-75DEA-EC)

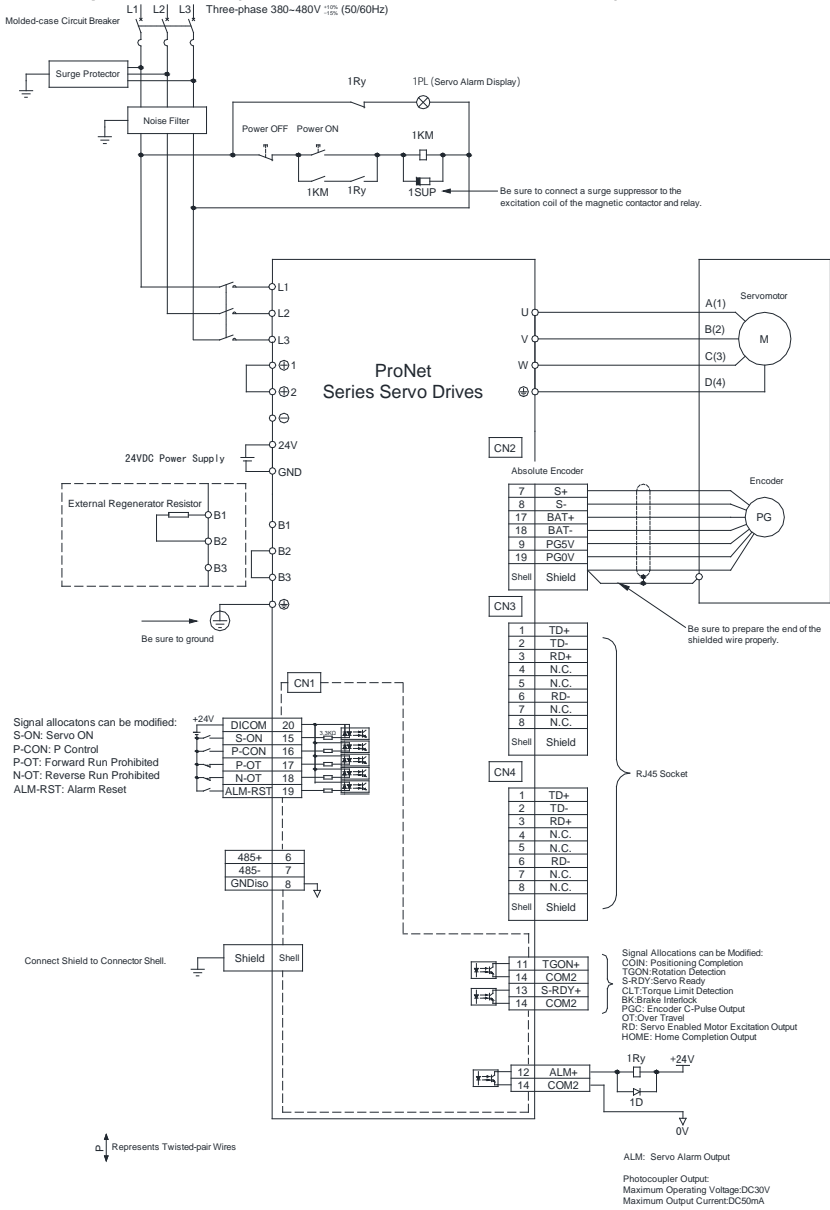

C.4 Three-phase 400VAC (ProNet-1ADEA-EC to ProNet-1EDEA-EC)

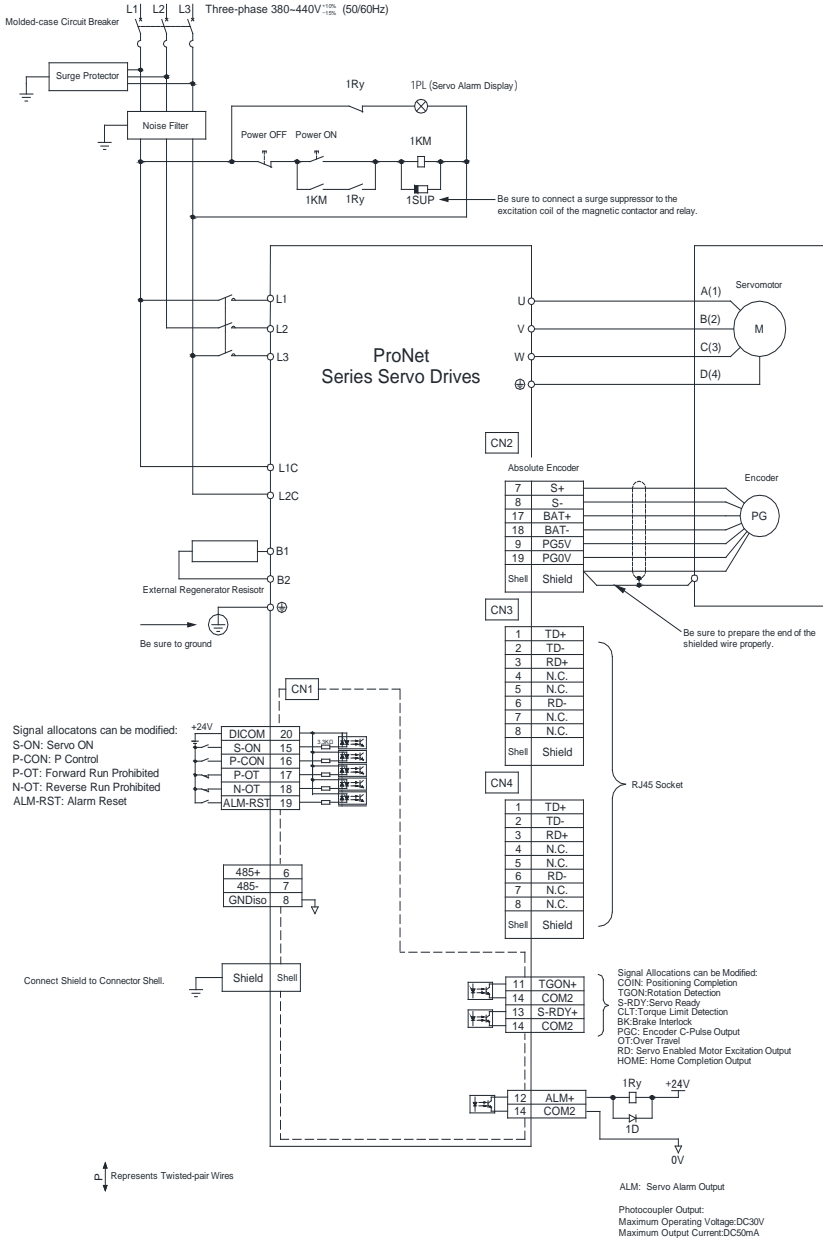



ESTUN AUTOMATION TECHNOLOGY CO., LTD.

Address: 16 Shuige Road, Jiangning Development Zone
Nanjing 211106, P.R.China

Tel: +86 (0)25-52785866

Fax: +86 (0)25-52785576

Web: www.estun.com

E-Mail: info@estun.com

www.estun.com

ESTUN