

# JetMove 203-230

## Drive



*JetWeb*

## User Manual



#### Edition 1.10

Jetter AG reserves the right to make alterations to its products in the interest of technical progress. These alterations need not be documented in every single case.

This manual and the information contained herein have been compiled with due diligence. Jetter AG shall not be liable for errors contained herein or for incidental or consequential damage in connection with the furnishing, performance, or use of this material.

The brand names and product names used in this manual are trade marks or registered trade marks of the respective title owner.

## How to Contact Us

Jetter AG  
Gräterstraße 2  
D-71642 Ludwigsburg  
Germany

Switchboard: 07141/2550-0  
Sales: 07141/2550-433  
Phone - Technical Hotline: (+49) 7141/2550-444

Fax - Sales: (+49) 7141/2550-484  
E-Mail - Sales: sales@jetter.de  
E-Mail - Technical Hotline: hotline@jetter.de  
Internet Address: http://www.jetter.de

## This User Manual is an Integral Part of the JetMove 203-230:

Type: \_\_\_\_\_  
Serial No.: \_\_\_\_\_  
Year of Manufacture: \_\_\_\_\_  
Order No: \_\_\_\_\_



To be entered by the customer:

Inventory No: \_\_\_\_\_  
Place of operation: \_\_\_\_\_

© Copyright 2006 by Jetter AG. All rights reserved.

# Significance of this Operator's Manual

This operator's manual is an integral part of the digital servo amplifier JetMove 203-230 and

- must be kept in a way that it is always at hand until the the digital servo amplifier JetMove 203-230 will be disposed of.
- Pass this manual on if the digital servo amplifier JetMove 203-230 is sold or loaned/leased out.

In any case you encounter difficulties to clearly understand the manual, please contact the manufacturer.

We would appreciate any kind of suggestion and contributions on your part and would ask you to inform us or to write us. This will help us to produce manuals that are more user-friendly and to address your wishes and requirements.

This manual contains important information on how to transport, erect, install, operate, maintain and repair the digital servo amplifier JetMove 203-230. Therefore, the persons carrying out these jobs must carefully read, understand and observe this manual, and especially the safety instructions.

Missing or inadequate knowledge of the manual results in the loss of any claim of liability on part of Jetter AG. Therefore, the operating company is recommended to have the instruction of the persons concerned confirmed in writing.

## History

Edition	Comment
1.00	First edition
1.10	Revisions, see Appendix A: "Recent Revisions", page 81 of edition 1.10

## Description of Symbols



**Warning**

This sign is to indicate a possible impending danger of serious physical damage or death.



**Caution**

This sign is to indicate a possible impending danger of light injury. This sign is also to warn you of material damage.



This sign indicates hazard of life due to electric shock caused by a high operating voltage.



This sign is to indicate hazard of serious physical damage or death due to accidentally touching dangerous parts of the device.



**Important**

This sign is to indicate a possible impending situation which might bring damage to the product or to its surroundings.

This symbol also points to conditions, which must by all means be given heed to, in order to guarantee faultless functioning.



**Note**

You will be informed of various possible applications and will receive further useful suggestions.

Further, it points to tips and advice for efficient use of the device and for optimization of the corresponding software, in order to save you extra work.

· / -

Enumerations are marked by full stops, strokes or scores.



Operating instructions are marked by this arrow.



Automatically running processes or results to be achieved are marked by this arrow.



PC and user interface keys.



This symbol refers to further information (data sheets, literature, etc.) on the subject or product or the like that is being dealt with. Further, this text provides helpful hints for your guidance through the manual.

---

# Table of Contents

<b>1</b>	<b>Safety Instructions</b>	<b>9</b>
1.1	General Information	9
1.1.1	Usage as agreed upon	9
1.1.2	Usage other than agreed upon	9
1.1.3	Who may operate the servo amplifier JetMove 203-230?	10
1.1.4	Modifications and alterations to the module	10
1.1.5	Repairs and servicing of the JetMove 203-230	10
1.1.6	Decommissioning and disposing of the JetMove 203-230	11
1.2	Ensure your Own Safety	12
1.2.1	Malfunctions	12
1.2.2	Information signs and labels	12
1.2.3	Earthing procedure	13
1.3	Residual Dangers	15
1.3.1	Hazards during operation	15
1.3.2	Hazards after POWER is turned OFF	17
1.4	Instructions on EMI	18
<b>2</b>	<b>Installing the JetMove 203-230</b>	<b>21</b>
2.1	Scope of Delivery	21
2.2	Mechanical Installation	22
2.3	Electrical Installation	24
2.4	Checking the Installation	25
2.5	Notes on Safety as regards the Installation	25
2.6	Safety Instructions for Commissioning	26
<b>3</b>	<b>Operating Conditions</b>	<b>27</b>
<b>4</b>	<b>Physical Dimensions</b>	<b>33</b>
<b>5</b>	<b>Technical Data</b>	<b>35</b>
5.1	Electrical Specification	35
5.2	Motor Protection	39
5.2.1	Thermal sensor integrated in the motor	39
5.2.2	I <sup>2</sup> t calculation	39
5.2.3	Motor overload calculation according to UL	41
<b>6</b>	<b>Drive Controller Structure</b>	<b>43</b>
<b>7</b>	<b>Description of Connections</b>	<b>45</b>
7.1	Power Supply	45
7.2	Motor Connection	47

---

7.2.1	General remarks	47
7.2.2	Assignment and specification	48
7.2.3	Motor power cable with mating connector SC	49
7.2.4	Connection assignment of terminal box	52
7.3	Connection of the Resolver	52
7.3.1	Specification	52
7.3.2	Resolver cable with mating connector	53
7.4	HIPERFACE Connection	55
7.4.1	Specification	55
7.4.2	HIPERFACE cable with mating connector	55
7.5	Digital Inputs, Logic Power Supply	58
7.6	Jetter System Bus	60
7.6.1	Specification of the Jetter system bus cable	60
<b>8</b>	<b>Status Monitoring</b>	<b>63</b>
<b>9</b>	<b>Diagnostics</b>	<b>65</b>
9.1	Error Messages	65
9.2	WARNINGS	69
<b>10</b>	<b>Wiring Diagrams</b>	<b>71</b>
<b>11</b>	<b>Analog Input (Option)</b>	<b>77</b>
11.1	Function	77
11.2	Technical Data	77
11.3	Description of Connections	78

## List of Appendices

Appendix A:	Recent Revisions	81
Appendix B:	Glossary	83
Appendix C:	List of Illustrations	86
Appendix D:	Index	87



# 1 Safety Instructions

## 1.1 General Information

The digital servo amplifier JetMove 203-230 fulfils the accepted safety regulations and standards. Special emphasis was given to the safety of the users.

The following additional regulations apply to the user:

- relevant accident prevention regulations;
- accepted safety rules;
- EC guidelines and other country-specific regulations.

### 1.1.1 Usage as agreed upon

Usage as agreed upon includes operation in accordance with these operating instructions.

**The digital servo amplifier JetMove 203-230 may only be operated in the closed control cabinet and within the range of the set values, see chapter 5 "Technical Data", page 35.**

**Do not apply a voltage to the digital servo amplifier JetMove 203-230 that is higher than the prescribed operating voltage.**

The operating voltage of the digital servo amplifier JetMove 203-230 ranges between AC 195 V and AC 265 V. Thus, the digital servo amplifier comes under the EC Low Voltage Directive.

**It is the explicit purpose of the servo controller JetMove 203-230 to torque-, speed- and/or position-control, and to drive brushless synchronous servo motors. The winding isolation of the motors must be higher than, or at least equal to, the DC link voltage supplied by the servo amplifier.**

The digital servo amplifier JetMove 203-230 is used to control machinery, such as conveyors, production machines, and handling machines.

### 1.1.2 Usage other than agreed upon

**The digital servo amplifier must not be used in technical systems which to a high degree have to be fail-safe, e.g. ropeways and aeroplanes.**

If the digital servo amplifier JetMove 203-230 is to be run under operating conditions, which differ from the conditions mentioned in chapter 3 "Operating Conditions", page 27, the manufacturer is to be contacted beforehand.

### 1.1.3 Who may operate the servo amplifier JetMove 203-230?

Only instructed, trained and authorised persons are permitted to operate the servo amplifier JetMove 203-230.

<b>Transport:</b>	Only by personnel with knowledge in handling electrostatically sensitive components.
<b>Installation:</b>	Only by specialists with training in electrical engineering.
<b>Commissioning:</b>	Only by specialists with extensive knowledge of and experience with electrical engineering / drive technology.

### 1.1.4 Modifications and alterations to the module

**Due to safety reasons, no modifications and alterations to the digital servo amplifier JetMove 203-230 and its functions are allowed.**

Any modifications to the servo amplifier JetMove 203-230 not expressly authorised by the manufacturer will result in a loss of any liability claims to Jetter AG.

**The original parts are specifically designed for the servo amplifier JetMove 203-230. Parts and equipment of other manufacturers are not tested on our part, and are therefore not released by us.**

The installation of such parts may impair the safety and the proper functioning of the digital servo amplifier JetMove 203-230.

From any damages resulting from usage other than agreed upon, e.g. the use of non-original parts and equipment, any claims with respect to the liability of Jetter AG are excluded.

### 1.1.5 Repairs and servicing of the JetMove 203-230

Repairs at the digital servo amplifier JetMove 203-230 must not be carried out by the operator. The servo amplifier JetMove 203-230 does not contain any parts to be repaired by the operator.

For being repaired, the servo amplifier JetMove 203 -230 must be sent to Jetter AG.

The digital servo amplifier JetMove 203-230 is maintenance-free. Therefore, no inspection or maintenance is required for the operation of the module.

## **1.1.6 Decommissioning and disposing of the JetMove 203-230**

The environmental regulations for the respective country apply to decommissioning and disposing of the digital servo amplifier on the operating company's premises.

You can disassemble the servo amplifier JetMove 203-230 into its main components by unscrewing it (aluminium heat sink and side plate, steel casing cover, electronic boards).

## 1.2 Ensure your Own Safety



Warning

- Isolate the digital servo amplifier JetMove 203-230 from the mains, if maintenance works have to be carried out. By doing so, you will prevent accidents resulting from electric voltage and moving parts. Please note chapter 1.3 "Residual Dangers", page 15.
- Safety and protective devices, e.g. the barrier and cover of the terminal box or the thermal motor circuit-breaker must not in any case be shunted or by-passed.
- Dismantled protective equipment, such as the fuses and the thermal motor circuit-breakers, must be reattached prior to commissioning and checked for proper functioning.
- Before commissioning, the machine manufacturer must carry out a hazard analysis of the respective machine and take adequate measures so that inadvertent motions will not lead to personal injury and to material damage.


### 1.2.1 Malfunctions


- **In the case of malfunctions or other faults, please immediately separate the digital servo amplifier JetMove 203-230 from the mains.** Please note chapter 1.3 "Residual Dangers", page 15.
- Malfunctions or other damages are to be reported to an authorized person immediately.
- Secure the servo amplifier JetMove 203-230 against misuse or accidental use.


### 1.2.2 Information signs and labels

- Writings, information signs, and labels always have to be observed and kept readable.
- Damaged or unreadable information signs and labels are to be exchanged.

### 1.2.3 Earthing procedure

 Screw the enclosure of the digital servo amplifier JetMove 203-230 onto a highly conducting, earthed panel.

 Do only use the servo amplifier JetMove 203-230 at the three-phase, earthed industrial network (TN network, TT network with earthed neutral, 5,000 A max, symmetric rated current at 400 / 480 V + 10 %). The servo amplifier must not be operated when connected to unearthed networks and to unsymmetrically earthed networks. One-phase connection to this power supply is only possible via one mains phase and the neutral conductor. Der drei-phasige Anschluss darf nur über einen Tenn- oder Spartransformator vorgenommen werden, (siehe auch chapter "Connection type of the voltage supply", page 35 und chapter 10 "Wiring Diagrams", page 71).

 **The digital servo amplifier JetMove 203-230 has got a leakage current greater than 3.5 mA. In order to avoid electric shocks, a second protective earth conductor will be required.**

For this, the following measures must be taken:

- The PE must be connected to the bolt (1) located at the top side of the rack, as well as to the PE terminal X1 (2); for this, please refer to 1. The cross-sectional area of the two earthing conductors must be equal to the cross-sectional area of the supply lines (1.5 mm<sup>2</sup> min.):
- A durable connection with the power supply of the digital servo amplifier JetMove 203-230 must be provided.
- Correct cabling of the PE bus according to the connection diagram (cf. chapter 10 "Wiring Diagrams", page 71) must be carried out.

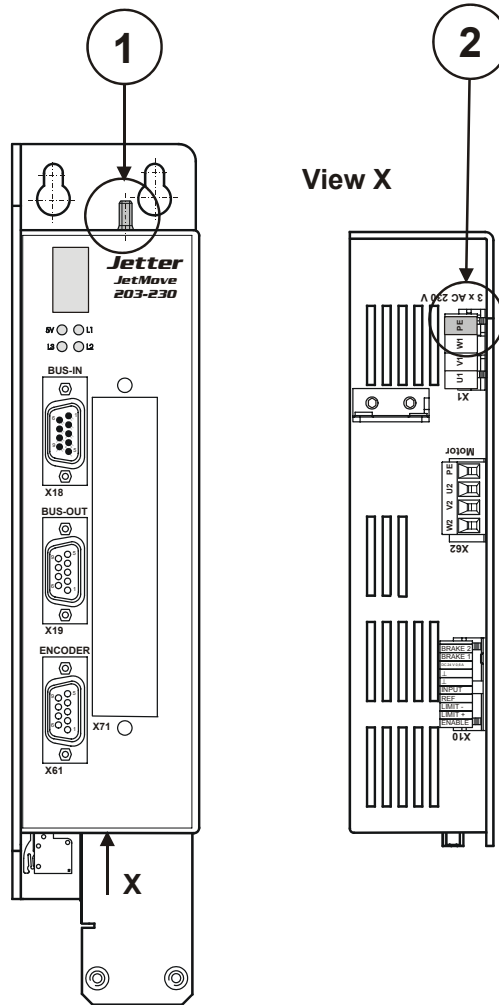


Fig.1: Double earthing



**Important!**



**Do not loop an earth-leakage current breaker into the mains power supply.**

Using an earth-leakage current breaker (FI) looped into in the mains power supply is not possible.

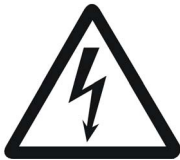
If, in spite of this, an earth-leakage current breaker is installed, it will switch off the digital servo amplifier JetMove 203-230, although there is no fault.

When a leakage current screen needs to be installed in the JetMove 203-230, an isolating transformer must be used.

## 1.3 Residual Dangers

### 1.3.1 Hazards during operation

#### HAZARD caused by high operating voltage!



**Warning**

#### Extremely hazardous voltages of up to DC 480 V may occur!

These voltages lead to muscle cramps, burns, unconsciousness, respiratory standstill, and death.

- During operation, all coverings and control cabinet doors must be kept closed.
- Do not open the device.
- Do by no means disconnect the electric connections of the servo amplifier JetMove 203-230 when it is live.
- **During operation, do not touch the screws of field wiring terminals X1 and X62.**



**Warning**

- In the given context, the terminals have the following meaning:
- X1:** AC 230 V supply voltage
  - X62:** DC Motors voltage of up to 480 V

#### DANGER of hot surfaces!



**Caution**

During operation, the surfaces, respectively the heat sinks of the servo amplifier JetMove 203-230 can heat up. The internal heat sink can reach temperatures of up to 90 °C.

- **Do by no means touch the enclosure of the digital servo amplifier JetMove 203-230 near the internal heat sink during operation and during the cooling-off period after switching off the device.**
- Please make sure that no temperature-sensitive parts have been connected or fastened to the servo amplifier JetMove 203-230.



Warning

## DANGER in potentially explosive atmosphere!



**Do not operate the digital servo amplifier JetMove 203-230 in a potentially explosive atmosphere.**



Caution

## DANGER of injuries caused by mechanic force!

The digital servo amplifier JetMove 203-230 runs a servo motor. This servo motor moves mechanic parts or sharp edges. Therefore, failure or malfunctioning of the digital servo amplifier JetMove 203-230 can be dangerous for a person or damage the manufacturing plant to an amount depending on the respective kind of plant. This should be prevented by installing additional safety precautions.

- One safety precaution is to install a second set of limit switches to interrupt the power supply of the motor.
- Another safety precaution would be to install a protection cover.



Make sure that hazards to persons are precluded even when the drive is moving unintentionally.



Do not dismount any necessary protective covers.



**Do not wear gloves**, lest they should get caught in the rotating drive shaft.



**Never touch a rotating drive shaft.**



Warning



## 1.3.2 Hazards after POWER is turned OFF

### DANGER resulting from electric shock!



**Warning**

Capacitors installed in the servo amplifier can still have dangerous voltages present up to five minutes after switching off the supply voltages.

- **Always** wait at least 5 minutes after switching off the device, before separating it from the mains or loosening the connections.
- **Always** wait at least 10 minutes after switching off the device before taking the following actions:
  - Touching the screws of the terminals X1 and X62;
  - Disconnecting the terminals and touching the contacts.

## 1.4 Instructions on EMI

The digital servo amplifier JetMove 203-230 is intended for use in industrial surroundings. It can cause radio interferences in residential areas. It is operated at the operator's own risk.

The noise immunity of a system corresponds to the weakest component of the system. For this reason, correct wiring and shielding of the cables is important.



### Important!

Measures for increasing immunity to interfering in electric plants:

- Earth the device adequately according to chapter 1.2.3 "Earthing procedure", page 13.
- Connect all grounding terminals of the JetMove 203-230. A double grounding terminal will be needed!
  - Connect the protective earth terminal located on the enclosure
  - Connect the protective earth (PE) conductor to terminal X1.see Fig. 1 on page 14
- Connect the motor lines. An optional mains filter must be as close to the servo amplifier as possible. Both sides of the cable must be shielded.
- If a motor power cable is used which includes cores for brake control, the brake control cores must be separately shielded. Earth the shielding at both ends. The shielding braid must be placed on both ends of the applicable cables.
- The distance between the optional line filters and the servo amplifier JetMove 203-230 must be kept as short as possible.
- Please follow the instructions given in Application Note 016 "EMC-Compatible Installation of the Electric Cabinet" published by Jetter AG.

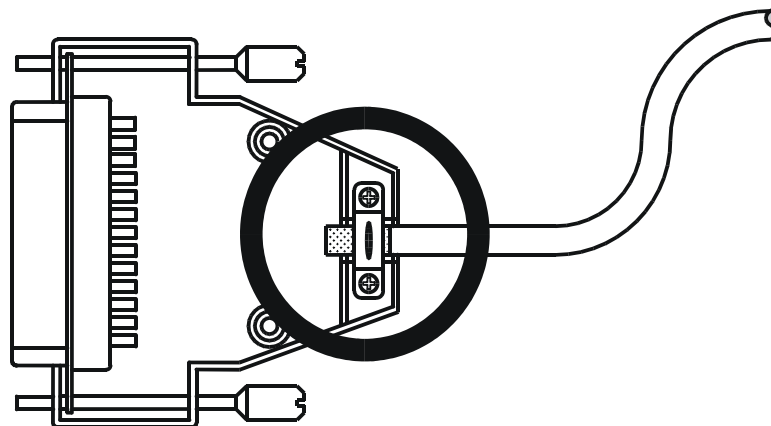
### The following instructions are excerpts from Application Note 016:

- Screw the enclosure of the digital servo amplifier JetMove 203-230 onto a highly conducting, earthed panel.
- On principle, **physical separation** should be maintained between signal and power lines. We recommend spacings greater than 20 cm. Cables and lines should cross each other at an angle of 90°.

- Shielded cables **must** be used for the following lines:  
Analog lines, data lines, motor cables coming from inverter drives (servo output stage, frequency converter), lines between components and interference suppressor filter, if the suppressor filter has not been placed at the component directly .
- Shield **both sides** of the cable.
- Unshielded wire ends of shielded cables should be as short as possible.
- The **entire** shield must be drawn behind the isolation, and then be **extensively** clamped under a flat earthed strain relief.

**If male connectors are used:**

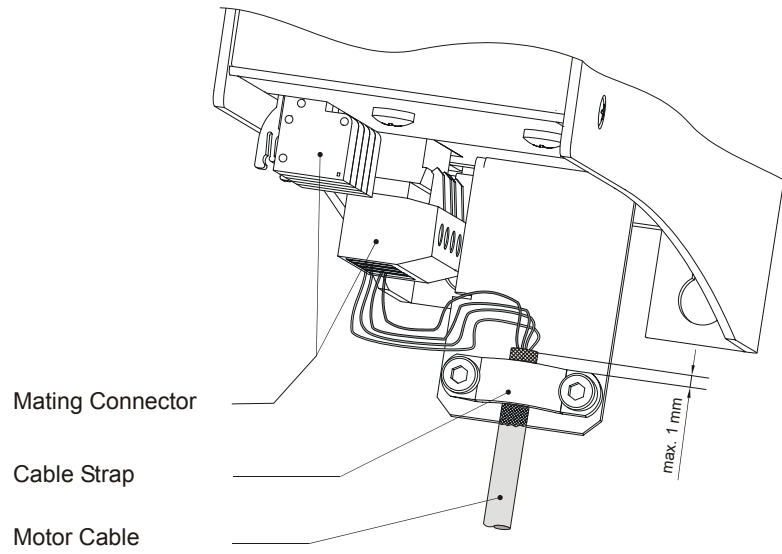
- The shield (impedance shielding) **must**, in its entire perimeter, be drawn behind the shielding clamp of the metallised connector housing, respectively of the EMC gland bushing, its greatest possible surface area being clamped under a strain relief.
- Only use metallised connectors, e.g. SUB-D with metallised housing.  
Make sure that the strain relief is directly connected with the housing here as well (see Fig. 2).



**Fig.2: Shielding of SUB-D connectors in conformity with EMC standards.**

**What to do, if the shield cannot be fixed to the connector, e.g. if the signal has been connected to terminal screws:**

- Shield and cable strap must be connected with low impedance to earthed surfaces. Earthing must be done in a way that keeps the unshielded part of the signal lines as short as possible (see Fig. 3).



**Fig.3: EMC-conformous shielding for terminal screws**

## 2 Installing the JetMove 203-230

### 2.1 Scope of Delivery

- Digital servo amplifier JetMove 203-230
- Mating connector, plugged on
- Cable strap serving as strain relief and motor power cable shield
- User manual

### Accessories

**The accessories are not included in the scope of delivery!**










- System bus cable of cable confection # 530 x.x m; length: 0.2 m through 5.0 m. Please refer to chapter 7.6 "Jetter System Bus", page 60.
- Motor power cable, see chapter 7.2 "Motor Connection", page 47.
- Resolver cable; please refer to chapter 7.3 "Connection of the Resolver", page 52.
- HIPERFACE cable; please refer to chapter 7.4 "HIPERFACE Connection", page 55.
- Motors, e.g. synchronous servo motors of the motor series JK or JL, made by Jetter AG.
- Motor circuit-breaker, see chapter 5 "Technical Data", page 35.
- Circuit-breaker, see chapter 5 "Technical Data", page 35.
- Isolating transformer or autotransformer
- Mounting screws, 2 pcs.; please refer to Fig. 4, page 23.

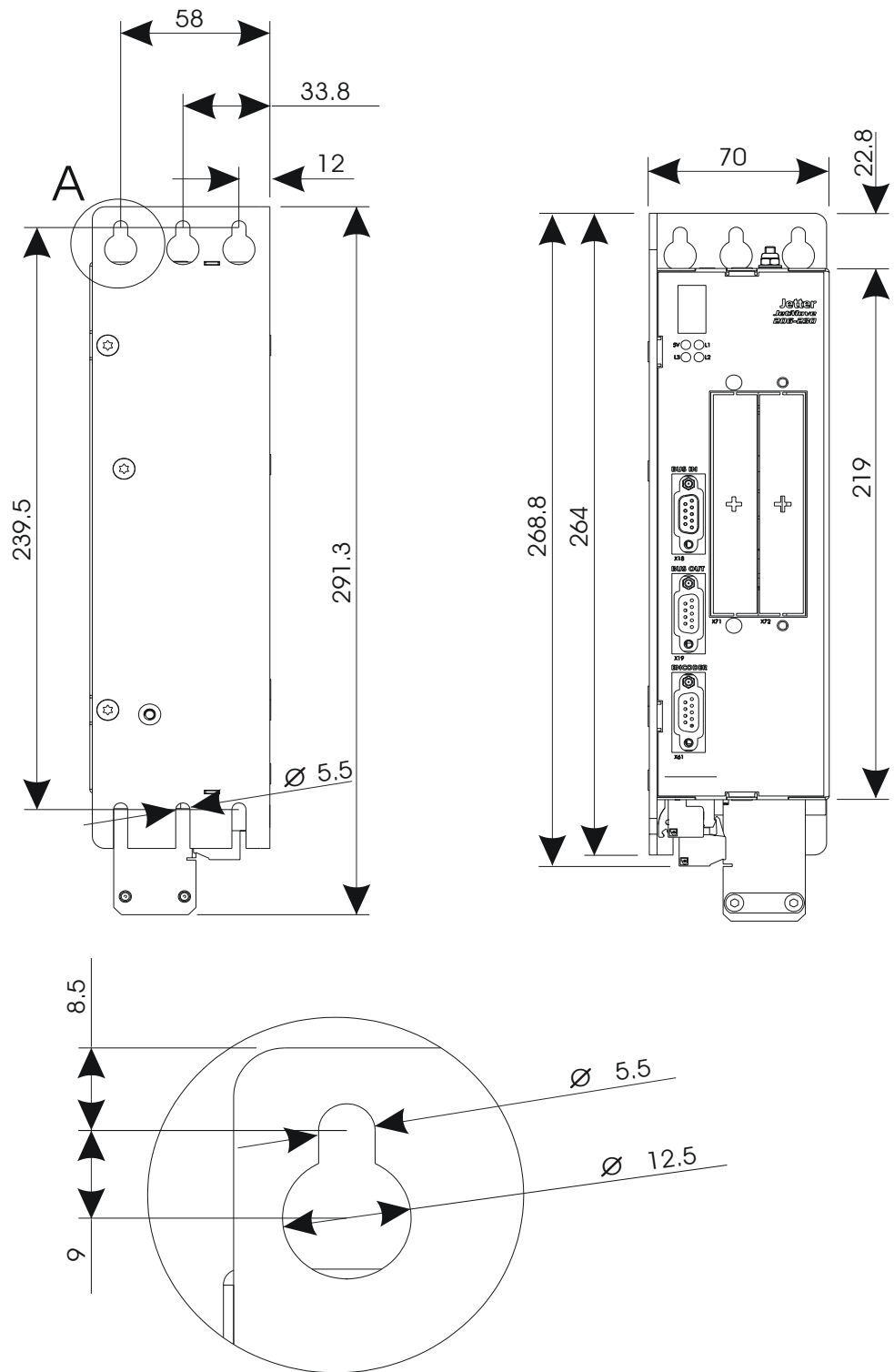


#### **Note!**

If you are not sure which mounting accessories you require, please contact Jetter AG.

## 2.2 Mechanical Installation

-  Prior to installing the digital servo amplifier, check it for possible transport damages.
-  Check the shipment for completeness.
-  To ensure proper functioning of the JetMove 203-230 check whether the mounting plate in the electric cabinet is unpainted.
-  The only possible mounting direction is vertical - see Fig. 4, page 23.
-  Please make sure there is a clearance of at least 100 mm under and above the JetMove 203-230 - unobstructed ventilation must be granted.
-  Please mark on the panel two positions for the fastening screw threads of the JetMove 203-230 (see Fig. 4, page 23).
-  Drill the holes and cut the thread into the panel.
-  Screw the corresponding fitting bolts into the thread by approximately half of their length.
-  By means of the oblong holes in the rear plate, hang up the JetMove 203-230 by the fitting bolts; then screw them tightly.



DETAIL A 4:1

Fig.4: Rear and front view of the enclosure with mounting holes

## 2.3 Electrical Installation



Check for correct motor and servo amplifier assignment.



Compare rated voltage and continuous rated current of servo amplifier and motor.

The motor must be isolated against voltages of DC 480 V min.; please also refer to "Compatible Synchronous Servo Motors" on page 39.



Connect the JetMove203-230 according to the connection wiring diagram shown in chapter 10 "Wiring Diagrams", page 71.

Especially check the power lines for appropriate protection, see "Overload protection" on page 35.

Protecting the motor cables is not advisable.



Select the cables according to standards.



Verify that all earthing cables are connected (double earthing).



To connect resolvers or power units you can use prefabricated cables available from Jetter or opt for self-made cables. Please refer to chapter 7 "Description of Connections", page 45.



To ensure that installation is carried out in conformance with EMC regulations, the following items have to be observed especially:

- If possible, run control cables and power cables separately;
- Connect resolver;
- Use shielded terminals or EMC-compatible connectors;
- Connect holding brake, if available, and connect shields on both sides of the cables;
- Connect the motor leads according to Fig. 3.

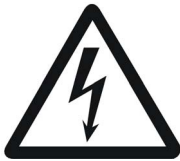
Please further note the chapter 1.4 "Instructions on EMI", page 18.



## 2.4 Checking the Installation

- Check motor and servo amplifier wiring and connections by means of the connection diagrams used.
- Check the holding brake, if existing, for proper functioning.
- Check to see whether all necessary protection measures against accidental contact with live or moving parts have been taken.
- Carry out any other checks specific to, or required, for your system.

## 2.5 Notes on Safety as regards the Installation



### Warning

**HAZARD caused by high operating voltage and electric shock!**

**Extremely hazardous voltages of up to DC 480 V may occur!**

Please observe the following precautions in order to avoid muscle cramps, burns, unconsciousness, respiratory standstill, etc., and death:

- Have installation and maintenance jobs carried out by qualified personnel only, see chapter 1.1.3 "Who may operate the servo amplifier JetMove 203-230?", page 10.
- Switch off the operating voltage.
- Consider the warnings of residual dangers in chapter 1.3.2 "Hazards after POWER is turned OFF", page 17.
- Before carrying out installation and maintenance jobs, separate the servo amplifier JetMove 203-230 and all connected devices from the mains (pull out the mains plug).

## 2.6 Safety Instructions for Commissioning



### Warning

**HAZARD caused by high operating voltage and electric shock!**

**Extremely hazardous voltages of up to DC 480 V may occur!**

Please observe the following precautions in order to avoid muscle cramps, burns, unconsciousness, respiratory standstill, etc., and death:

- Have commissioning jobs carried out by qualified personnel only, see chapter 1.1.3 "Who may operate the servo amplifier JetMove 203-230?", page 10.

### Before switching on

- Reattach dismantled protective equipment and check it for proper functioning.  
By doing so, you will prevent accidents resulting from movable parts.
- Secure the servo amplifier JetMove 203-230 against accidental contact with conductive parts and components.
- Only connect devices or electrical components to the signal lines of the digital servo amplifier JetMove 203-230 (Enable, Limit+/-, REF, BRAKE 1 and BRAKE 2) that have been sufficiently isolated against the connected electric circuits. These signal lines may only be connected with units that have got the ground potential of the DC 24 V power supply.
- Accordingly, do only connect resolver, HIPERFACE and servo motor with the servo amplifier, if they have been sufficiently isolated from the connected power supply.
- The digital servo amplifier JetMove 203-230 has got a leakage current greater than 3.5 mA. In order to avoid electric shocks, a second protective earth conductor will be required.  
For this, the measures listed in chapter 1.2.3 "Earthing procedure", page 13 must be taken.
- Each commissioning, even a short functional test, must always be carried out with a PE bus correctly connected.

### 3 Operating Conditions

Operating Parameters Connected Load		
Parameters	Value(s)	Standard Specification(s) Referred to
Connected load	Switching device: 3 * AC 230 V, 50 / 60 Hz (AC 195 V through AC 265 V)  Logic part: DC 24 V, SELV / PELV <= 0.6 A (DC 20 V through DC 30 V)	
Supply fluctuations	Speed of changing the frequency: 2 %/s max. Voltage imbalance: 2 % max. Voltage dips: 3 ms max.	

Operating Parameters Environment		
Parameters	Value(s)	Standard Specification(s) Referred to
Operating conditions	Temperature: 0 °C to +45 °C (+45 °C to +55 °C: Derating 2.5 %/K) Air humidity: 5 % to 85 %, non-condensing	DIN EN 50178
Storage conditions (units within packing)	Temperature: -25 °C to +55 °C, Maximum fluctuation: 20 K/h Air humidity: 5 % to 95 %, non-condensing Maximum storage period: < 1 year without restrictions	DIN EN 50178
Transport conditions (units within packing)	Temperature: -25 °C to +70 °C Air humidity: 5 % to 95 %, non-condensing	DIN EN 50178
Pollution degree	2	DIN EN 50178
Corrosion immunity / Chemical resistance	No special protection against corrosion. Ambient air must be free from higher concentrations of acids, alkaline solutions, corrosive agents, salts, metal vapours, or other corrosive or electroconductive contaminants	-

Operating Parameters Environment		
Operating altitude	1,000 m max. above sea level From 1,000 to 2,500 m above sea level; derating 1.5 % per 100 m increase in altitude	DIN EN 50178

Operating Parameters Mechanical Parameters		
Parameters	Value(s)	Standard Specification(s) Referred to
Transport stability	Within original packing, the device withstands dropping over all of its edges	DIN EN 50178 DIN EN 60068-2-31
Vibration resistance	<ul style="list-style-type: none"> <li>• 10 Hz - 57 Hz: 0.075 mm amplitude</li> <li>• 57 Hz - 150 Hz: 1.0 g constant acceleration</li> <li>• 1 octave per minute, 10 frequency sweeps (sinusoidal), all three spatial axes</li> </ul>	DIN EN 50178 DIN EN 60068-2-6
Degree of protection	IP 20	DIN EN 60529
Mounting position	Vertical Please make sure there is a clearance of at least 100 mm under and above the JetMove 206B-230 - sufficient ventilation must be granted.	



### Important!

Measures to avoid damages in transit and storage:



The packaging material and the storage place are to be chosen in a way that the values given in the above table "Operating Parameters Mechanical Parameters" on page 28 are kept to.

<b>Operating Parameters Electrical Safety</b>		
<b>Parameters</b>	<b>Value(s)</b>	<b>Standard Specification(s) Referred to</b>
Protection class	I	DIN EN 50178
Dielectric strength	Protective network conductor and network logics: 1.7 kV, 5 s	DIN EN 50178 DIN EN 60204-1
Insulation	Protective network conductor and network logics: > 1 MOhm at 500 V	DIN EN 50178
Protective earth connection	12 V, 10 A, 0.1 Ohm	DIN EN 60204-1
Overvoltage category	III	DIN EN 50178 DIN VDE 0110-1 UL 508C

<b>Operating Parameters EMI Emitted Interference</b>		
<b>Parameters</b>	<b>Value(s)</b>	<b>Standard Specification(s) Referred to</b>
Enclosure	<ul style="list-style-type: none"> <li>• Frequency band 30 - 230 MHz, limit 30 dB (<math>\mu\text{V}/\text{m}</math>) in 30 m</li> <li>• Frequency band 230 - 1000 MHz, limit 37 dB (<math>\mu\text{V}/\text{m}</math>) in 30 m</li> </ul> (First surroundings, restricted availability)	DIN EN 61800-3
Alternating network current	Frequency band: <ul style="list-style-type: none"> <li>• 0.15 - 0.5 MHz, limit 79 dB (<math>\mu\text{V}</math>)*</li> <li>• 0.5 - 30 MHz, limit 73 dB (<math>\mu\text{V}</math>)*</li> </ul> * Measuring by means of the quasi-peak detector (First surroundings, restricted availability)	DIN EN 61800-3



### Important!



This is a product of restricted availability according to IEC/EN 61800-3. This module can cause radio interferences in residential areas. In this case, the user must take adequate measures to prevent this.

Additional line filters can be helpful here. See "Line filter" on page 36.

<b>Operating Parameters EMI Immunity to Interference Enclosure</b>		
<b>Parameters</b>	<b>Value(s)</b>	<b>Standard Specification(s) Referred to</b>
ESD	Discharge through air: Test peak voltage 8 kV Contact discharge: Test peak voltage 6 kV Criterion B (Second surroundings, restricted availability)	DIN EN 61800-3 DIN EN 61000-4-2
RF field amplitude-modulated	Frequency band 80 -1000 MHz; test signal strength 10 V/m AM 80 % with 1 kHz Criterion A (Second surroundings, restricted availability)	DIN EN 61800-3 DIN EN 61000-4-3

<b>Operating Parameters EMI Immunity to Interference Power Connections</b>		
<b>Parameters</b>	<b>Value(s)</b>	<b>Standard Specification(s) Referred to</b>
Burst (fast transients)	Test voltage 2 kV Repetition rate 5 kHz Criterion B (Second surroundings, restricted availability)	DIN EN 61800-3 DIN EN 61000-4-4
Impulse voltages	tr/th 1,2/50 $\mu$ s, 8/20 $\mu$ s 1 kV (launching phase conductor against phase conductor) 2 kV (launching phase conductor against ground potential) (Second surroundings, restricted availability)	DIN EN 61800-3 DIN EN 61000-4-5
Guided radio disturbances	Frequency 0.15 - 80 MHz Test voltage 10 V AM 80 % with 1 kHz Criterion A (Second surroundings, restricted availability)	DIN EN 61800-3 DIN EN 61000-4-6

<b>Operating Parameters EMI Immunity to Interference Power Interfaces</b>		
Parameters	Value(s)	Standard Specification(s) Referred to
Burst (fast transients)	Test voltage 2 kV Repetition rate 5 kHz Capacitive interference Criterion B (Second surroundings, restricted availability)	DIN EN 61800-3 DIN EN 61000-4-4

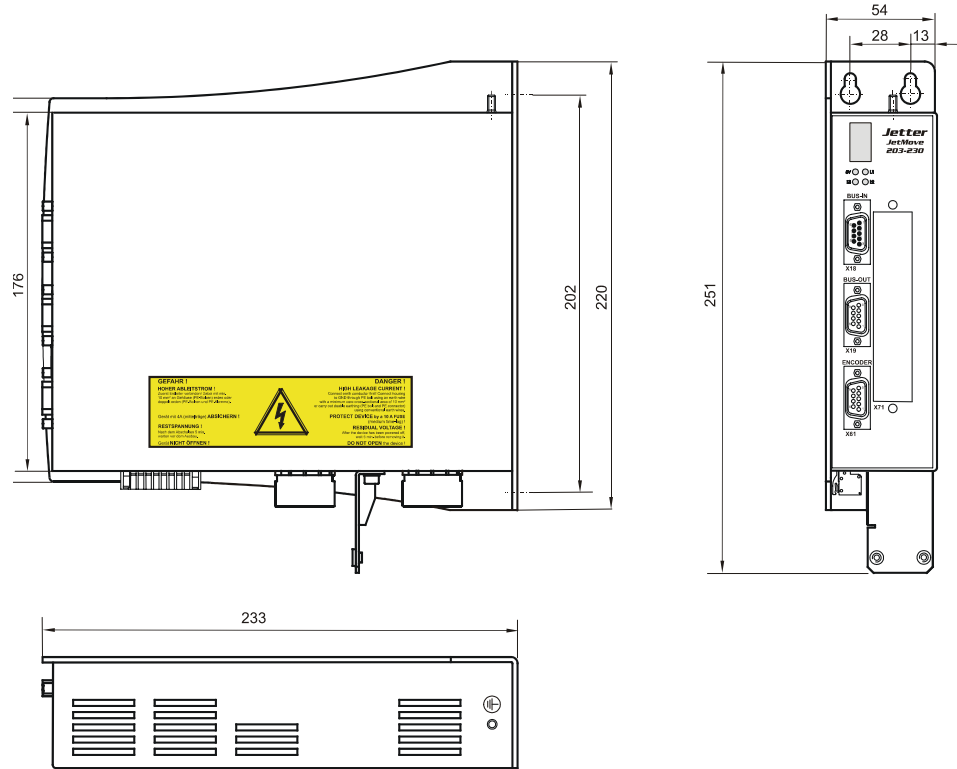
<b>Operating Parameters EMI Immunity to Interference Measuring and Control Circuits in Process Environments</b>		
Parameters	Value(s)	Standard Specification(s) Referred to
Burst (fast transients)	Test voltage 2 kV Repetition rate 5 kHz Capacitive interference Criterion B (Second surroundings, restricted availability)	DIN EN 61800-3 DIN EN 61000-4-4
Guided radio disturbances	Frequency 0.15 - 80 MHz Test voltage 10 V AM 80 % with 1 kHz Criterion A (Second surroundings, restricted availability)	DIN EN 61800-3 DIN EN 61000-4-6

<b>Operating Parameters EMI - Immunity to Interference Signal Interfaces</b>		
Parameters	Value(s)	Standard Specification(s) Referred to
Burst (fast transients)	Test voltage 1 kV Repetition rate 5 kHz Capacitive interference Criterion B (Second surroundings, restricted availability)	DIN EN 61800-3 DIN EN 61000-4-4

<b>Operating Parameters EMI - Immunity to Interference Signal Interfaces</b>		
Guided radio disturbances	Frequency 0.15 - 80 MHz Test voltage 10 V AM 80 % with 1 kHz Criterion A (Second surroundings, restricted availability)	DIN EN 61800-3 DIN EN 61000-4-6



## 4 Physical Dimensions



**Fig.5: Mounting dimensions of the JetMove 203-230**

For installation, please also refer to Fig. 4 on page 23



## 5 Technical Data

### 5.1 Electrical Specification

Electrical Specification	
Voltage of the rated power supply	<ul style="list-style-type: none"> <li>• Direct supply <math>U_{\text{eff}} = 230 \text{ V}</math> Common mode of the voltage 2 % max. Voltage dips 3 ms max.</li> <li>• 48 ... 62 Hz Frequency change 2 % / s max.</li> </ul>
Connection type of the voltage supply <ul style="list-style-type: none"> <li>• for a rated motor output of &gt; 1kW, a three-phase connection is compulsory)</li> </ul>	<ul style="list-style-type: none"> <li>• one-phase: direct (<math>U_{\text{eff}} = 230\text{V}</math>: L to N)</li> <li>• three-phase: by means of auto- or isolating transformer e.g. in primary circuit: <math>U_{\text{eff}} = 3 \times 400 \text{ V}</math>. in secondary circuit: <math>U_{\text{eff}} = 3 \times 230 \text{ V}</math></li> </ul> <p><b>See "Note 1!" on page 37.</b></p>
Power supply tolerance	$U_{\text{eff}} = 195 \text{ V} \dots 265 \text{ V} (-15 \% \dots + 15 \%)$
Inrush current limitation	<45 A limited to 10 ms during the switch-on-sequence  <p><b>See "Time between deactivating and activating the mains power supply" on page 37</b></p>
Overload protection	For each phase an external overload protection is required, for example <ul style="list-style-type: none"> <li>– Circuit breaker 4 A C</li> <li>– Fuse 4 A M (medium time-lag)</li> <li>– Motor circuit breaker 4 A</li> </ul>
Motor output voltage	Three-phase with 380 V typical (480 V max.)
Motor output current at an ambient temperature of 45 °C	Nominal current: $I_{\text{eff}} = 3 \text{ A}$ Peak current for 30 seconds minimum: $I_{\text{eff}} = 6 \text{ A}$ (The duration depends on the temperature of the heat sink)  <p><b>See "Note 2!" on page 37.</b></p>
Continuous power of motor	0.5 kW
Short-circuit protection, motor side	Designed for <ul style="list-style-type: none"> <li>• phase to phase</li> <li>• phase to earth</li> </ul>
Motor overload protection	See "Motor Protection" on page 39.

<b>Electrical Specification</b>	
Cross-sectional area of supply-cable conductors	Min. 0.75 mm <sup>2</sup>
Cross-sectional area of motor supply cable	Min. 0.75 mm <sup>2</sup> , 50 m length max. (if you need greater lengths, please contact Jetter AG)
Line filter	<p>Line filter ensuring unrestricted EMC in a residential environment to DIN EN 61800-3. The following filters can be applied with input circuits:</p> <ul style="list-style-type: none"> <li>– NEFB 10332 with I<sub>r</sub> = 16 A</li> <li>– NEFB 10333 with I<sub>r</sub> = 25 A</li> <li>– NEFB 10334 with I<sub>r</sub> = 36 A</li> </ul> <p><b>See "Note 3!" on page 37.</b></p>
Voltage supply of processor logics (demands on power supply module)	<ul style="list-style-type: none"> <li>• 24 V DC (20 .. 30 V)</li> <li>• ≤ 0.6 A</li> <li>• The voltage output of the power supply unit must comply with the SELV or PELV type.</li> </ul>
Internal ballast resistor	<ul style="list-style-type: none"> <li>• Resistor: 200 Ω</li> <li>• Continuous power: 100 W</li> <li>• Maximum capacity: internally limited to 1 kW at 0.6 s (warning and error message)</li> </ul>
Residual voltage	To avoid hazard of electrical shock wait at least 5 minute after switching-off the digital servo amplifier before attempting to pull out the plug or remove this unit (refer to page 17).
Leakage current	<p>&gt; 3.5 mA</p> <p><b>See "DANGER resulting from electric shock!" on page 38.</b></p>
Enable (E), Reference switch (R); Limit switch RH (L+), and limit switch LH (L+); Input (Inp)	<ul style="list-style-type: none"> <li>• DC 20 V ... 30 V related to the controller potential</li> <li>• 7.5 mA max. input current per input</li> <li>• See chapter 7.5 "Digital Inputs, Logic Power Supply", page 58</li> </ul>

<b>Electrical Specification</b>	
Braking relay (contacts: Br1 and Br2)	Can be switched via controller program, or automatically at release of the motor current supply. $U_{\max.} = \text{DC } 30 \text{ V}$ $I_{\max.} = 2 \text{ A}$ Kind of contact: Type NO These contacts may only be connected to devices that are related to the same potential as the power supply of the controller logic.
Power dissipation $P_v$	25 W max.

**Note 1!****When a transformer is used:**

The neutral point on the secondary side of the circuit must be grounded.

**Note 2!****Cooling:**

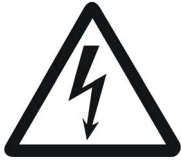
- The overtemperature protection is activated at 85 °C.
- The overtemperature alarm is activated at 75 °C
- The duration for the peak current is measured at a starting temperature of 45 °C at the heat sink.

**Note 3!**

A line filter can supply several digital servo amplifiers JetMove 203-230, as soon as  $I_f$  (the current of the line filter) is greater than the total current of the connected servo amplifiers.

**Important****Time between deactivating and activating the mains power supply**

If, after running the drive by means of engine power (speed and torque at the motor), the power supply has been switched off, the inrush current limitation must cool down for 2-3 minutes. If this is not given heed to, the component causing the inrush current limitation can be destroyed.

**DANGER resulting from electric shock!****Warning**

In order to prevent electric shocks, ground the digital servo amplifier JetMove 203-230 **by all means** via two positions; for this, refer to chapter 1.2.3 "Earthing procedure", page 13.

### Compatible Synchronous Servo Motors

Motor types	Jetter motors of the JL, JK and JH series, as well as Bautz motors of the M and F series
-------------	--



#### Note!

In case you intend to use motors other than the above mentioned types, please contact Jetter AG.

## 5.2 Motor Protection

Three kinds of motor protection have been implemented into the servo amplifier JetMove 203-230:

### 5.2.1 Thermal sensor integrated in the motor

The servo amplifier JetMove 203-230 can read out and process three different motor temperature sensors:

Sensor type	Type of sensor signal evaluation
KTY83-110	Temperature is measured in °C The warning threshold can be set Error detection at maximum motor temperature
PTC	Go-no-go decision Error detection at maximum motor temperature
Temperature switch	Go-no-go decision Error detection at maximum motor temperature

### 5.2.2 I<sup>2</sup>t calculation

The servo amplifier JetMove 203-230 calculates a model of motor power losses by an I<sup>2</sup>t calculation. The calculated value is a measure of the average power loss of the motor and is calculated in percent of the maximum motor power loss.

For this calculation it is important for the parameters

- nominal current (which is the minimum of nominal motor current and nominal servo amplifier current).
  - overload factor
  - and time constant of the motor
- are programmed in correctly.

The I<sup>2</sup>t evaluation must be activated via JetSym or via the PLC program. It is possible to parameterise the warning level. The error level (error 30) is set to 100%.

The I<sup>2</sup>t value is readable in a variable of JetMove 203-230 through JetSym or the PLC.

The servo amplifier JetMove 203-230 calculates the percentage of the motor load according to the following formula:

$$x(t) = 100\% \times \left( \frac{\text{average motor current}}{\text{rated current}} \right)^2 \times \left( 1 - e^{-\frac{t}{T}} \right)$$

x(t) = Displayed value of the motor load in %

t = Time since start of the motor by this continuous current (in seconds)

T = Motor time constant (in seconds)

The formula shows that the 100% value will never be reached as long as the average motor current is not greater than the continuous rated current of the motor.

Further the calculated value always starts with value 0 (with (t = 0) the result of the equation is zero) and its change practically approaches zero for a time much higher than the motor time constant.

The time until deactivating the motor (x = 100 %) is a result of the following formula:

$$t = -T \times \ln \left[ 1 - \left( \frac{\text{rated current}}{\text{average motor current}} \right)^2 \right]$$

After activating, the values for the significant parameters to be entered are the following:

Continuous rated current: 3 A

Overload factor: 2

Motor time constant: 1800 s (30 min.)

With these parameters the 100 % error level will be reached if, for example the motor is run by a current of 6 A for about 8 minutes and 30 seconds.



**Important**

As, after activating, the I<sup>2</sup>t calculation always starts with value zero, the motor load can only be calculated correctly, if, at activating the servo amplifier JetMove 203-230 (i.e. it has been connected to the 24 V logic power supply and parametering the I<sup>2</sup>t function has been completed) is cold.



### 5.2.3 Motor overload calculation according to UL

For driving motors at a servo amplifier, the UL standard requires a motor load recognition which functions according to the following criteria:

The "trip current" is defined to be 1.15 times the user-set nominal current.

- If the average motor current corresponds to the trip current, this must lead to deactivating the motor after a limited time.
- If the value of the average motor current equals the double value of the trip current, the motor current must be switched off after 8 minutes as the latest.
- If the value of the average motor current equals six times the value of the trip current, the motor current must be switched off after 20 seconds as the latest.

This motor overload protection (error message 31 will occur) can be parameterised only through the parameter "continuous rated current". It is always active and cannot be deactivated.



**Important**

As, after activating, the motor overload calculation to UL always starts with value zero, the motor load can only be calculated correctly, if, at activating the servo amplifier JetMove 203-230 (i.e. it has been connected to the 24 V logic power supply) is cold.



## 6 Drive Controller Structure

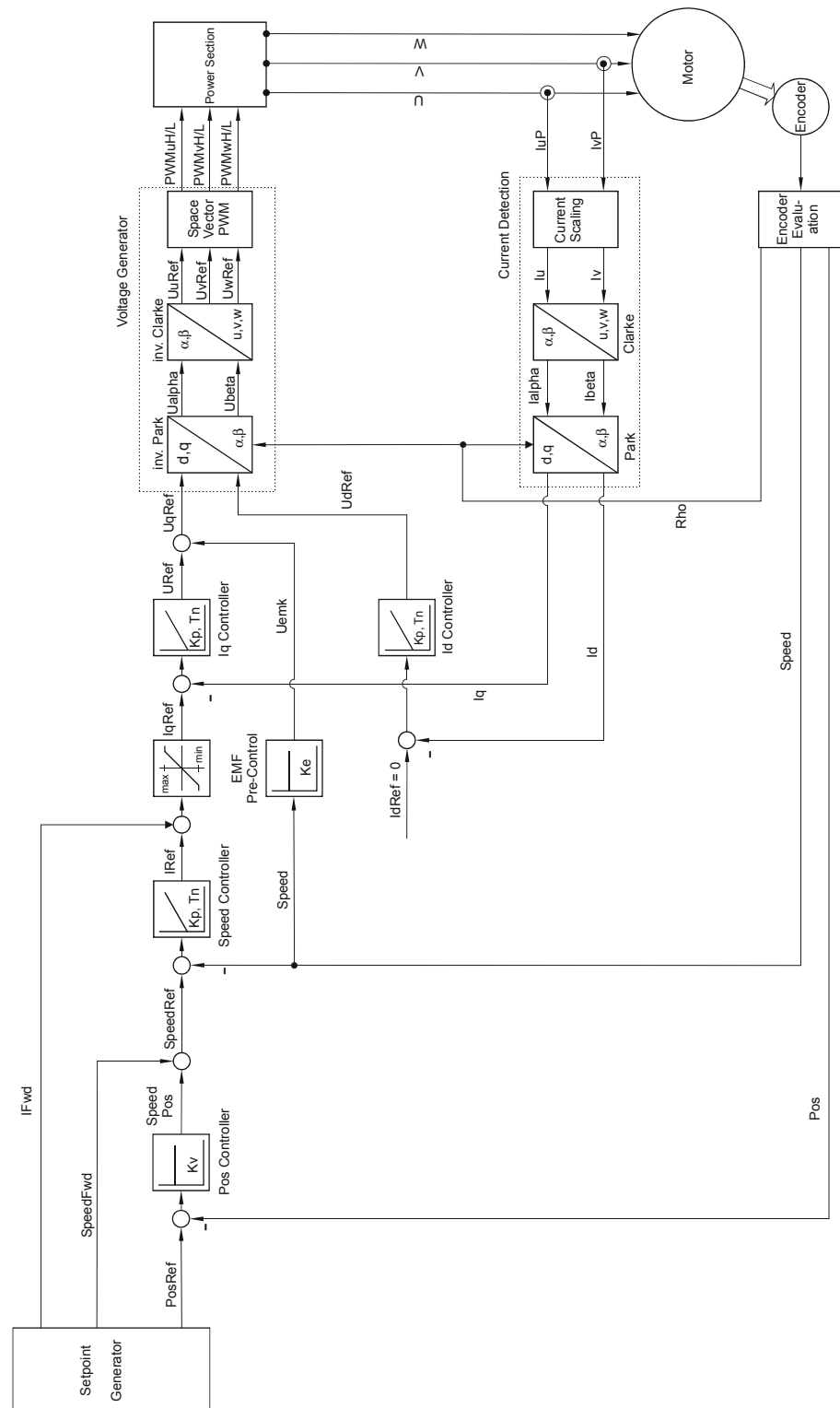


Fig.6: Block diagram of drive controller structure

## Drive Controller Specification

All drive controllers can be parameterized through the control program.

Function	Comment
<b>Motor control</b> (commutation)	Space vector modulation
<b>PWM Frequency</b>	16 kHz
<b>Current control</b> – Cycle time	62.5 $\mu$ s
<b>Speed Control</b> – Cycle time – Current pre-control	125 $\mu$ s adjustable
<b>Position control</b> – Cycle time – Speed pre-control	250 $\mu$ s adjustable
<b>Position setpoint generator</b> – Sine-square and linear acceleration/deceleration ramps – Setpoint output cycle (position feedback controller interpolation)	can be parameterized individually 2 ms
<b>Position sensing</b>  <b>Resolver:</b> – Resolution – Sampling interval  <b>Sine-cosine sensor</b> (multi- and single-turn): – Interface – Resolution of absolute position – Resolution of velocity pickup – Sampling interval	  12 bits per revolution 62.5 $\mu$ s  HIPERFACE 15 bits per revolution 20 bits per revolution 62.5 $\mu$ s

# 7 Description of Connections

## 7.1 Power Supply

### Specification of terminal X1

- 4-pin spring energy terminal (type ZEC 1.5/ 4-ST-7.5 C2 R1,4; for printed circuit boards)
- Rewirable core cross-section: 0.25 - 1.5 mm<sup>2</sup>
- Bladed screw-driver: 0.6 x 3.5 x 100 mm<sup>2</sup>

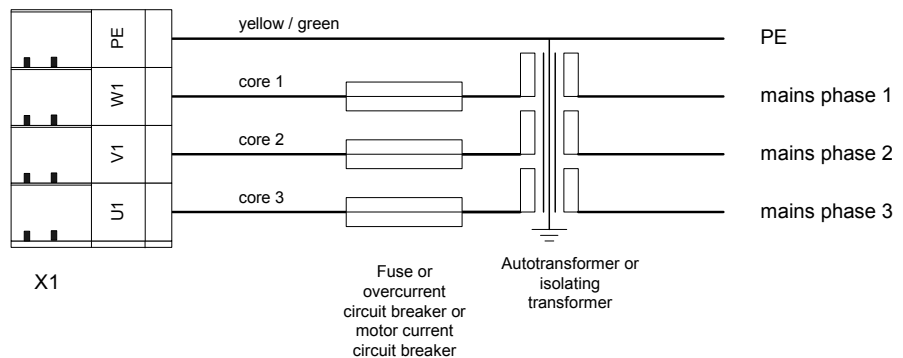
### Specification of cables

- Cable size: 4 \* 0.75 mm<sup>2</sup>
- Material: Copper
- Temperature class: 60 °C
- Stripping length of the cores: 6 mm
- Bootlace ferrules are not required

### Cable shielding

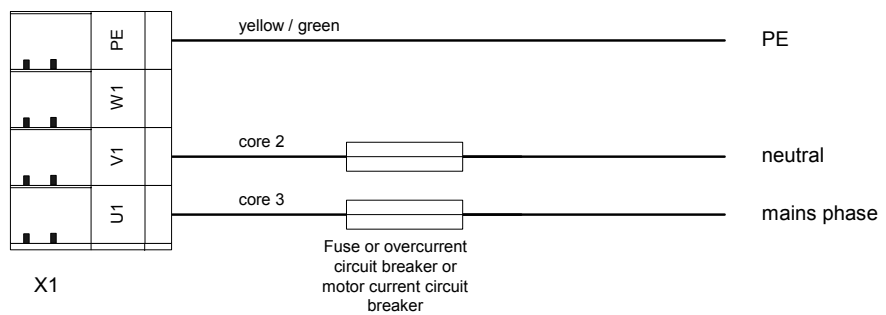
- Not required

Power Supply 3-Phase Connection		
Terminals X1 on the amplifier side	Signal	Specification
U1	L1	• AC 230 V between the power lines
V1	L2	
W1	L3	
PE	PE conductor	



**Fig.7: Connection of the 3-phase supply line**

Power Supply 1-phase connection		
Terminals X1 on the amplifier side	Signal	Specification
U1	L	• AC 230 V between mains phase and direct earth conductor
V1	N	
W1		
PE	PE conductor	



**Fig.8: Connection of the 1-phase supply line**



**Note**

One-phase connection is only possible up to a motor rating of 0.5 kW.

## 7.2 Motor Connection

### 7.2.1 General remarks



#### Important!

Alternative measures to avoid malfunctions of the control system and the motor:



Operate the brake via a separately shielded brake line. The distance between brake line and motor power cable should be greater than 20 cm. This is the preferred solution.



Always connect brake lines to a separate power supply unit DC 24 V if brake and motor lines are run together in one bunch of cables, and are not separately shielded.



#### Important!

Measures to avoid oscillation and blocking of the motor:



Avoid mixing-up of phase cables, resp. be sure to connect the phase cables according to pin assignment.

## 7.2.2 Assignment and specification

### Specification of the connector for terminal X62

- 4-pin connector (type PC 4/ 4-ST-7.62)
- Rewirable core cross-section: 0.25 - 4 mm<sup>2</sup>
- Bladed screw-driver: 0.6 x 3.5 x 100 mm<sup>2</sup>
- Stud torque of terminal blocks: 0.5 Nm - 0.6 Nm

### Specification of the motor cable

- Cable size: 4 \* 0.75 mm<sup>2</sup>
- Material: Copper
- Temperature class: 60 °C
- Stripping length of the cores: 6 mm
- Bootlace ferrules are recommended

### Cable shielding

- Braided copper shield of 80% coverage

Connection of the motor to the digital servo amplifier JetMove 203-230 has to be done following the wiring diagram below. (Connection of the brake is optional)

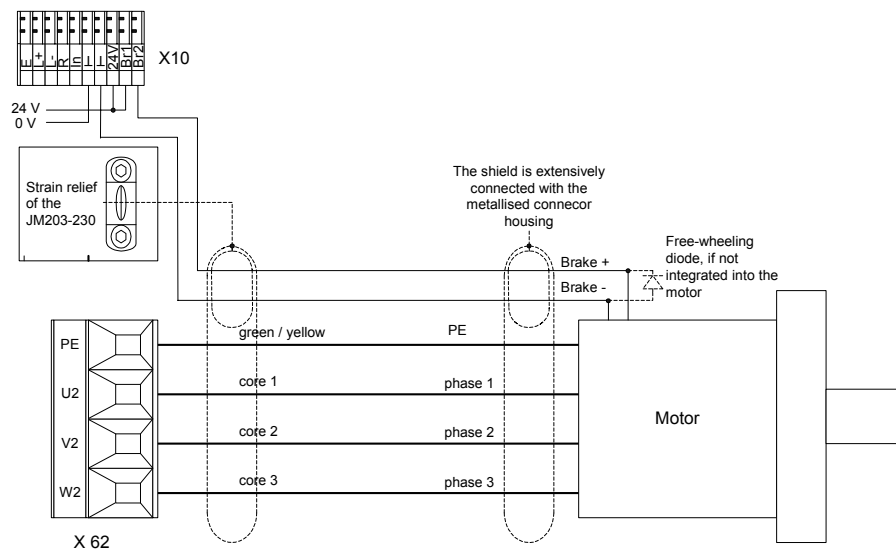


Fig.9: Connection of motor lines



### 7.2.3 Motor power cable with mating connector SC



**Note!**

The suitable mating connector SC (female connector) can be ordered from Jetter AG by supplying the following particulars:

- Article # 15100070      Motor connector for the Jetter motor series JL2, JL3, JL4, JK4, JK5, JK6, and for the Bautz motor series M25, M40, F50, F63, F80 without brake
- Article # 15100105      Motor connector for the Jetter motor series JL2, JL3, JL4, JK4, JK5, JK6, and for the Bautz motor series M25, M40, F50, F63, F80 with brake



**Note!**

The motor connector with mating connector SC (female connector) suitable for the Jetter motor series JL2, JL3, JL4, JK4, JK5, JK6 and for the Bautz motor series M25, M40, F50, F63, F80 can be ordered from Jetter AG by supplying the following particulars: It is confectioned with the matching motor mating connector and can be ordered by the following cable confection numbers:

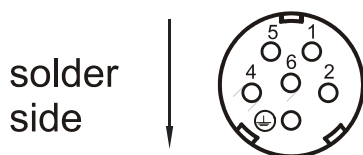
**Without brake:**

Cable confection #  
26.1

**With brake:**

Cable confection #  
24.1

**View on the mating connector of the motor (solder side)**



**Fig.10: View on the SC series mating connector of the motor (internal thread M23)**

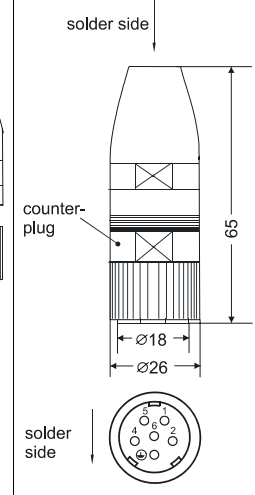
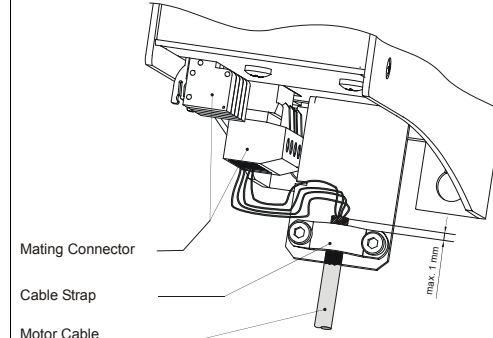
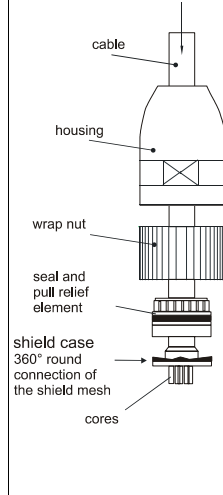

## Cable specification of the motor power cable with mating connector SC for JetMove 203-230

For connection without motor holding brake

<b>Motor power cable of cable confection # 26.1</b>			
<b>Field Wiring Terminals of the JetMove 203-230</b>	<b>Shielding</b>		<b>Mating connector of the motor (female, solder side)</b>
<p>4 x 0.75 mm<sup>2</sup> The wires are equipped with bootlace ferrules.</p>	<p>Shielded, highly flexible 4-wire cable with PE.</p>		
	<p>Connect both sides of the shield with the greatest possible surface area! Metalized enclosure necessary!</p>		
<b>Pin</b>	<b>Wire number</b>	<b>Signal</b>	<b>Pin</b>
X62.U2	1	Phase 1	1
X62.V2	2	Phase 2	5
X62.W2	3	Phase 3	2
X62.PE	Yellow-green	PE conductor	


The measurements of the motor mating connector have been specified in millimeters.

For connection with motor holding brake

<b>Motor power cable of cable confection # 24.1</b>			
<b>Field Wiring Terminals of the JetMove 203-230</b>	<b>Shielding</b>		<b>Mating connector of the motor (female, solder side)</b>
<p>7 x 0.75 mm<sup>2</sup> The wires are equipped with bootlace ferrules.</p>	<p>Shielded, highly flexible 6-wire cable with PE.</p>		
			
	<p>Connect both sides of the shield with the greatest possible surface area! Metallized enclosure necessary!</p>		
<b>Pin</b>	<b>Wire number</b>	<b>Signal</b>	<b>Pin</b>
X62.U2	1	Phase 1	1
X62.V2	2	Phase 2	5
X62.W2	3	Phase 3	2
X62.PE	Yellow-green	PE conductor	
X10.BRAKE2	5	Brake +	6
X10.GND	4	Brake -	4

The measurements of the motor mating connector have been specified in millimeters.

## 7.2.4 Connection assignment of terminal box

Connection Assignment of Terminal Box <sup>*)</sup>		
Amplifier terminals	Motor Terminal Box - Terminal Assignment	
X62.U2	Pin 1	Phase 1
X62.V2	Pin 2	Phase 2
X62.W2	Pin 3	Phase 3
X62.PE	Pin 4	 Protective earth
X10.BRAKE2	Pin 7	Brake +
X10.GND	Pin 8	Brake -

<sup>\*)</sup> alternatively to motor connectors

## 7.3 Connection of the Resolver

### 7.3.1 Specification

#### Specification of the connector for terminal X61 (ENCODER)

- 9-pin male SUB-D connector
- Metallised enclosure

#### Specification of the resolver cable

- Cable size: 3 \* 2 \* 0.14 mm<sup>2</sup> + 2 \* 0.5 mm<sup>2</sup>  
2 \* 0.5 mm<sup>2</sup> must be used for the thermal sensor
- Cores have to be shielded and twisted in pairs and must be included in an overall shielding
- The shield must be connected to the connector housings on both ends of the cable with the greatest possible surface area.
- Material: Copper
- Temperature class: 60 °C
- Maximum cable length: 50 m

## 7.3.2 Resolver cable with mating connector



### Note!

The resolver respectively HIPERFACE mating connector of the synchronous servo motor series JL and JK can be ordered from Jetter AG by supplying the following particulars:

Article # 15100069      Resolver / HIPERFACE

The complete resolver cable connecting the servo amplifier series JetMove 2xx and the synchronous servo motor series JL und JK can be ordered from Jetter AG.

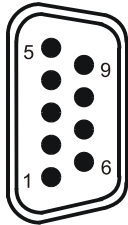
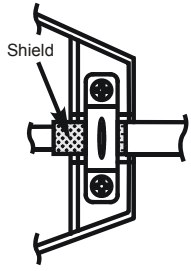
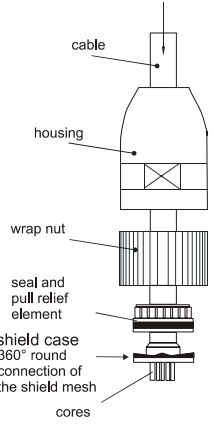
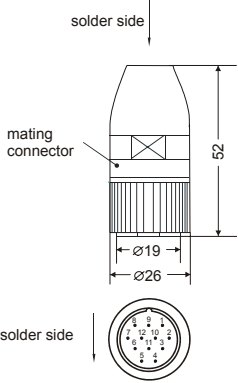
It can be ordered by supplying the following cable confection number:

Cable confection # 23      For the servo amplifier series JetMove 2xx

### Viewing the mating connector of the resolver (solder side)



**Fig.11: Viewing the RC series mating connector of the resolver (internal thread M23)**

Resolver cable of cable confection # 23			
JetMove 2xx (SUB-D connector X61)	Shielding		Motor (Resolver) (female, solder side)
 <p>Attaching screws must have a metric thread!</p>			
<p>Connect shield with the greatest possible surface area! Metallized enclosure necessary!</p>			
Pin	Signal	Core Color	Pin
8	S1 (cosine +)	red	1
3	S3 (cosine -)	blue	2
2	S4 (sine -)	yellow	3
7	S2 (sine +)	green	4
1	R1R (exciter winding +)	pink	5
6	R2L (exciter winding -)	gray	6
9	Th1 (thermal sensor)	white	7
4	Th2 (thermal sensor)	brown	8
-	unassigned	-	9 - 12

The measurements of the resolver mating connector have been specified in millimeters.

## 7.4 HIPERFACE Connection

### 7.4.1 Specification

#### Specification of the connector for terminal X61 (ENCODER)

- 9-pin male SUB-D connector
- Metallised enclosure

#### Specification of HIPERFACE cable

- Cable size:  $4 * 2 * 0.14 \text{ mm}^2 + 2 * 0.5 \text{ mm}^2$   
 $2 * 0.5 \text{ mm}^2$  must be used for power supply and GND
- Twisted-pair cables shielded with the all-over shield must be used; the signal lines must also be twisted in pairs:
  - Sine + and reference sine
  - Cosine + and reference cosine
  - DATA - and DATA +
  - 0 V and power supply
- The shield must be connected to the connector housings on both ends of the cable with the greatest possible surface area.
- Material: Copper
- Temperature class: 60 °C
- Maximum cable length: 50 m

### 7.4.2 HIPERFACE cable with mating connector



#### Note!

The resolver respectively HIPERFACE mating connector of the synchronous servo motor series JL and JK can be ordered from Jetter AG by supplying the following particulars:

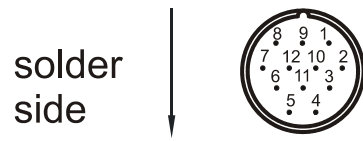
Article # 15100069      Resolver / HIPERFACE

The complete HIPERFACE cable between the servo amplifier series JetMove 2xx and the synchronous servo motor series JL and JK can be ordered from Jetter AG..

It can be ordered by supplying the following cable confection number:

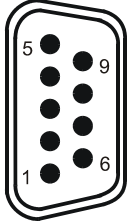
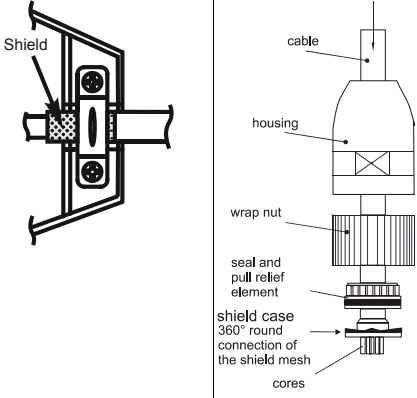
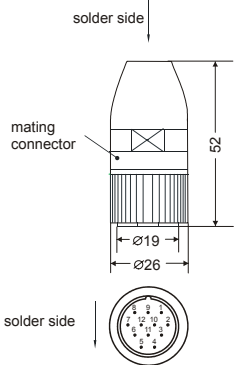
Cable confection # 723      For the servo amplifier series JetMove 2xx

**HIPERFACE mating connector (solder side)**



**Fig.12: RC series HIPERFACE mating connector (internal thread M23)**



<b>HIPERFACE cable of cable confection # 723</b>			
<b>JetMove 2xx (SUB-D connector X61)</b>	<b>Shielding</b>		<b>Motor (HIPERFACE) (female, solder side)</b>
 <p style="text-align: center;">Attaching screws must have a metric thread!</p>			
	<p>Connect shield with the greatest possible surface area! Metallized enclosure necessary!</p>		
<b>Pin</b>	<b>Signal</b>	<b>Core Color</b>	<b>Pin</b>
-	unassigned	-	1
-	unassigned	-	2
7	Sine +	white	3
2	Reference sine	brown	4
8	Cosine +	green	5
3	Reference cosine	yellow	6
6	DATA - (RS-485)	gray	7
1	DATA + (RS-485)	pink	8
4	0 V	blue	9 <sup>*)</sup>
5	Voltage supply (7 through 12 volts)	red	10
9	Thermo sensor	black	11
	Thermo sensor	-	12 <sup>*)</sup>

<sup>\*)</sup> Pin 9 and Pin 12 are short-circuited  
Dimensions of the HIPERFACE mating connector are specified in millimeters.

## 7.5 Digital Inputs, Logic Power Supply

Digital Inputs, Logic Power Supply			
Wiring terminal X10 at the amplifier	Signal	Function	Specification
ENABLE	Hardware enable for the power supply of the motor (Input)	<ul style="list-style-type: none"> <li>At this input, a high signal is necessary for power supply of the motor. (This signal must have been applied before carrying out the software enable)</li> <li>A low signal de-energizes the motor immediately.</li> </ul>	<ul style="list-style-type: none"> <li>DC 24 V</li> <li>7.5 mA max.</li> <li>Operating point: &lt; 6 V low, &gt; 15 V high</li> </ul>
REF	Reference switch (Input)	<ul style="list-style-type: none"> <li>Depending on the parameter setting, this input is used for reference run</li> </ul>	<ul style="list-style-type: none"> <li>DC 24 V</li> <li>7.5 mA max.</li> <li>Operating point: &lt; 6 V low, &gt; 15 V high</li> </ul> <p>NC or NO contact</p>
LIMIT +	Positive limit switch (input)	<ul style="list-style-type: none"> <li>Depending on the parameter setting, this input is used as a positive limit switch.</li> </ul>	<ul style="list-style-type: none"> <li>DC 24 V</li> <li>7.5 mA max.</li> <li>Operating point: &lt; 6 V low, &gt; 15 V high</li> </ul> <p>NC or NO contact</p>
LIMIT -	Negative limit switch (input)	<ul style="list-style-type: none"> <li>Depending on the parameter setting, this input is used as a negative limit switch.</li> </ul>	<ul style="list-style-type: none"> <li>DC 24 V</li> <li>7.5 mA max.</li> <li>Operating point: &lt; 6 V low, &gt; 15 V high</li> </ul> <p>NC or NO contact</p>
INPUT	Digital Input	<ul style="list-style-type: none"> <li>Depending on the parameter setting, this input can be used for quick stop, position capture or referencing without stop.</li> </ul>	<ul style="list-style-type: none"> <li>DC 24 V</li> <li>7.5 mA max.</li> <li>Operating point: &lt; 6 V low, &gt; 15 V high</li> </ul>

⊥	Common ground		Ground <sup>*)</sup> for all inputs and supply of the logic
⊥	Common ground		Ground <sup>*)</sup> for all inputs and supply of the logic
DC 24 V	Voltage supply of processor logics		DC 20 .. 30 V (I < 0.6 A)
BRAKE 1	Braking relay contact Br1	Relay contact for motor holding brake	$V_{\max} = \text{DC } 30 \text{ V}$ $I_{\max} = \text{DC } 2 \text{ A}$
BRAKE 2	Braking relay contact Br2	The relay can be operated either by the control program or by the firmware of the JetMove 203-230 at release of the motor current.  A free-wheeling diode is necessary if not integrated in the motor already.	Type NO  These connections are only for devices having got the same reference to ground as the power supply of the logic.

<sup>\*)</sup> is connected to the ground of the control system.

## 7.6 Jetter System Bus

The JetMove 203-230 is interlinked with the controller, additional JetMove amplifiers, or Jetter peripheral modules by means of the Jetter system bus. The system bus input BUS-IN is a 9-pin male Sub-D connector, and the bus output BUS-OUT is a 9-pin female Sub-D connector.

### 7.6.1 Specification of the Jetter system bus cable

#### Specification of the connectors

##### On the BUS-OUT (X19) side

- 9-pin male SUB-D connector
- Metallised enclosure

##### On the BUS-IN (X18) side

- 9-pin female SUB-D connector
- Metallised enclosure

#### System bus cable specification

To the manufacture of the system bus cable the following minimum requirements apply:

Technical Data of System Bus Cable	
Function	Description
Cable size	1 MBaud: 0.25 through 0.34 mm <sup>2</sup>
	500 kBaud: 0.34 through 0.50 mm <sup>2</sup>
	250 kBaud: 0.34 through 0.60 mm <sup>2</sup>
	125 kBaud: 0.50 through 0.60 mm <sup>2</sup>
Capacity of cable	Maximum 60 pF/m
Specific resistance	1 MBaud: Maximum 70 Ω /km
	500 kBaud: Maximum 60 Ω /km
	250 kBaud: Maximum 60 Ω /km
	125 kBaud: Maximum 60 Ω /km
Number of cores	5
Shielding	Complete, not paired
Twisting	Cores for CL and CH must be twisted

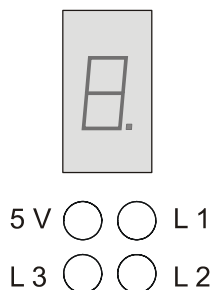
Permissible Cable Lengths			
Baud rate	Max. cable length	Max. stub line length	Max. overall stub line length
1 MBaud	30 m	0.3 m	3 m
500 kBaud	100 m	1 m	39 m
250 kBaud	200 m	3 m	78 m
125 kBaud	200 m	-	-

System Bus Cable of Cable Confection # 530			
		Shielding	
<b>BUS-OUT</b>	Connect shield with the greatest possible surface area! Metallized enclosure necessary!		<b>BUS-IN</b>
<b>Pin</b>	<b>Signal</b>		<b>Pin</b>
1	CMODE0		1
2	CL		2
3	GND		3
4	CMODE1		4
5	TERM		5
6	Vacant		6
7	CH		7
8	Vacant		8
9	Do not connect		9



## 8 Status Monitoring

The amplifier LEDs indicate the operating status of the digital servo amplifier.



JetMove 203-230 - LEDs			
LED	Colour	State	Meaning
5V	Green	is lit	Logic module voltage is OK
L1	Yellow	is lit	Axis is standing still (speed = 0)
L2	Yellow	is lit	A voltage of 24 V is applied to the input of the positive limit switch (LIMIT+).
L3	Yellow	is lit	A voltage of 24 V is applied to the input of the negative limit switch (LIMIT-).

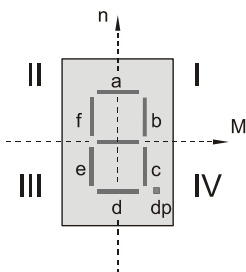


### Note!

The 7-segment display of the output stage indicates the operating and fault conditions of the digital servo amplifier JetMove 203-230. The various display modes are set by the Motion Setup. Mode 0 (default) is used for normal operation and mode 1 for commissioning.

JetMove 203-230 - 7-Segment Display Mode 0: Normal Operation		
Display	State	Meaning
0	NOT READY TO BE SWITCHED ON	Initialisation of amplifier functions
1	INITIALIZATION COMPLETE	Initialization completed. Safe state. Is achieved after initialising and after acknowledging errors. The drive controller can be switched on.
2	READY TO BE SWITCHED ON	Drive controller has been disabled by software command. The drive controller can be switched on.
3	SWITCHED ON	DC link monitoring is activated.
4	OPERATION_ENABLED	The drive controller has been enabled.

JetMove 203-230 - 7-Segment Display Mode 0: Normal Operation		
<b>7</b>	QUICK STOP ACTIVATED	A quick stop has been activated. The drive is being decelerated to $n = 0$ and then locked.
<b>E</b>	ERROR REACTION ACTIVATED	An error has been recognized. An adjustable error reaction may be active.
<b>F</b>	MALFUNCTION	The drive controller is locked, error can be acknowledged.
<b>F X. X.</b>	ERROR NUMBER	Fault with number X. X. has occurred
<b>.</b>	Flashing dot	Warning activated
<b>0.</b>	Flashing "ZERO"	Boot sector has been activated
<b>C.</b>	Flashing "C"	OS flash is being deleted
<b>E.</b>	Flashing "E"	OS flash is being deleted
<b>L.</b>	Flashing "L"	OS loader being loaded
<b>P.</b>	Flashing "P"	OS is being transferred to the flash memory
<b>U.</b>	Flashing "U"	The boot sector waits for OS update



JetMove 203-230 - 7-Segment Display Mode 1: Commissioning		
Display	Meaning	Meaning
<b>g</b>	$n_{\text{Actual Value}} < 0.5 \% n_{\text{max.}}$	--
<b>b</b>	$M > 0, n > 0$ --> quadrant I	Mode of operation - Motor
<b>c</b>	$M < 0, n > 0$ --> quadrant II	Mode of operation - Generator
<b>e</b>	$M < 0, n < 0$ --> quadrant III	Mode of operation - Motor
<b>f</b>	$M > 0, n < 0$ --> quadrant IV	Mode of operation - Generator
<b>a</b>	The positive current limit has been reached	--
<b>d</b>	The negative current limit has been reached	--



## 9 Diagnostics

### 9.1 Error Messages



#### Note!

In the case of an error message, the letter "F" and two successive numbers appear on the 7-segment display every second.

Error Message Table JetMove 203-230				
Error Number	Type of Error	Description	Effect	Error Correction
<b>F 00</b>	Hardware error	Internal hardware defect	– Immediate pulse disable	– Cut drive controller from power lines – Return the amplifier for repair
<b>F 01</b>	Internal voltage supply error	One or more power supply voltages are beyond their limits	– Immediate pulse disable	– Cut drive controller from power lines – Return the amplifier for repair
<b>F 02</b>	One mains phase has failed (is only active in case of a 3-phase connection)	Failure of one of the mains phases	– Immediate pulse disable	– Check fuses and wiring – Acknowledge failure
<b>F 03</b>	Motor cable fault	The motor cable is broken  Please note: The motor cable is tested when the drive controller is enabled for the first time	– Immediate pulse disable	– Check the motor cable connections – Acknowledge failure
<b>F 04</b>	DC link overvoltage	A DC link voltage of > 480 V has been detected	– Immediate pulse disable	– Check input voltage supply – If the motor is used as a generator, reduce the regenerating power – Acknowledge failure

**Error Message Table JetMove 203-230**

<b>Error Number</b>	<b>Type of Error</b>	<b>Description</b>	<b>Effect</b>	<b>Error Correction</b>
<b>F 05</b>	Current overload	The output current has been greater than 2.5 x the rated current	– Immediate pulse disable	<ul style="list-style-type: none"> <li>– Check cable and motor for a short circuit</li> <li>– Check current control parameters. If necessary, correct parameters</li> <li>– Acknowledge failure</li> </ul>
<b>F 06</b>	Overload internal ballast resistor	The ballast resistor has been overloaded	– Immediate pulse disable	<ul style="list-style-type: none"> <li>– Let the drive controller cool down</li> <li>– After cooling down, acknowledge failure</li> <li>– Reduce regeneration power</li> </ul>
<b>F 07</b>	Shutdown threshold for device temperature	The amplifier has reached the maximum temperature	– Immediate pulse disable	<ul style="list-style-type: none"> <li>– Let the drive controller cool down</li> <li>– After cooling down, acknowledge failure</li> <li>– Reduce power of drive system</li> </ul>
<b>F 08</b>	Shutdown threshold for motor temperature	The motor has reached the maximum temperature	– Immediate pulse disable	<ul style="list-style-type: none"> <li>– Let the motor cool down</li> <li>– After cooling down, acknowledge failure</li> <li>– Reduce the power of the drive</li> </ul>
<b>F 09</b>	Encoder error	Encoder breakage or initialization error	– Immediate pulse disable	<ul style="list-style-type: none"> <li>– For extended diagnostics purposes use motion setup</li> <li>– Check the encoder line and all plug-in connections</li> <li>– Acknowledge failure</li> </ul>
<b>F 10</b>	Overspeed	The actual shaft speed has exceeded a value of 1.25 x maximum speed	– Immediate pulse disable	<ul style="list-style-type: none"> <li>– Check motor and encoder connections</li> <li>– Check speed controller parameters. If necessary, modify parameters</li> <li>– Acknowledge failure</li> </ul>
<b>F 11</b>	Current overrange	A current temporarily too high has been detected	– Immediate pulse disable	<ul style="list-style-type: none"> <li>– Reduce <math>K_p</math> of the current controller by 10 to 20 %</li> <li>– Acknowledge failure</li> </ul>

<b>Error Message Table JetMove 203-230</b>				
<b>Error Number</b>	<b>Type of Error</b>	<b>Description</b>	<b>Effect</b>	<b>Error Correction</b>
<b>F 12</b>	Earth fault	One or more phases of the motor cable or inside the motor have been short-circuited to earth	– Immediate pulse disable	– Check the motor cable and the motor – Acknowledge failure
<b>F 13 (combined with F00)</b>	Internal checksum error	An internal checksum error has occurred	– Immediate pulse disable	– Switch the 24 V supply off and on again – If the error occurs repeatedly, return the amplifier for repair
<b>F 14 (combined with F 00)</b>	Internal communication error	An internal communication error has occurred	– Immediate pulse disable	– Switch the 24 V supply off and on again – If the error occurs repeatedly, return the amplifier for repair
<b>F 15</b>	The hardware enable is missing	The software enable is given without a hardware enable	– Immediate pulse disable	– Disable the drive by means of the software – Acknowledge failure
<b>F 16</b>	Power input over current	The current at the power input was too high	– Immediate pulse disable	– Check input voltage – Reduce mechanical power of the motor – Acknowledge failure
<b>F 17</b>	Trip of software limit switch	Actual position is outside the range of software limits and software limit switches are active	– Stop with max. current (torque)	– Check destination position – Acknowledge failure – Run axis back inside the range of software limits (software limit switches will be active automatically by entering this range)
<b>F 18</b>	Trip of hardware limit switch	One hardware limit switch was activated	– Stop with max. current (torque)	– Check destination position – Check reference position – Acknowledge failure – Run axis back inside the range of hardware limits (software limit switches will be active automatically at leaving the switch)

**Error Message Table JetMove 203-230**

<b>Error Number</b>	<b>Type of Error</b>	<b>Description</b>	<b>Effect</b>	<b>Error Correction</b>
<b>F 20</b>	Undervoltage DC link voltage	The DC link voltage is less than the minimum value	– Stop with emergency stop ramp	– Check the voltage of the power line – Check the parameter "U <sub>ZK</sub> min. trip" – Acknowledge failure
<b>F 21</b>	Overvoltage DC link voltage	The DC link voltage has exceeded the maximum value	– Stop with emergency stop ramp	– Check the voltage of the power line – In generator operation reduce braking power – Acknowledge failure
<b>F 22</b>	The drive has stalled	The drive could not overcome the n = 0 threshold within the time limit specified by the parameter "blocking-triping time"	– Immediate pulse disable	– Eliminate the cause of stalling – Acknowledge failure
<b>F 23</b>	Tracking error	The tracking error has exceeded the limit defined in the parameter "tracking error limit" for the time specified in "tracking window time"	– Stop with emergency stop ramp	– Check the drive mechanism – Check steepness of acceleration/ deceleration ramps and amplifier parameters in relation to the parameters "tracking error limit" and "tracking window time" – Acknowledge failure
<b>F 24 (combined with F 01)</b>	Error in 24 V supply voltage	External 24 V supply was lower than 18 V	– Immediate pulse disable	– Check external power supply – Acknowledge failure
<b>F 25 - F 27 (combined with F 01)</b>	Internal supply error	one or more internal supply voltages has fallen below their limit	– Immediate pulse disable	– Note the number of error – Return the amplifier for repair
<b>F 29</b>	Mains power too high	The average mains power is too high	– Immediate pulse disable	– Acknowledge failure – Reduce the average load of the motor

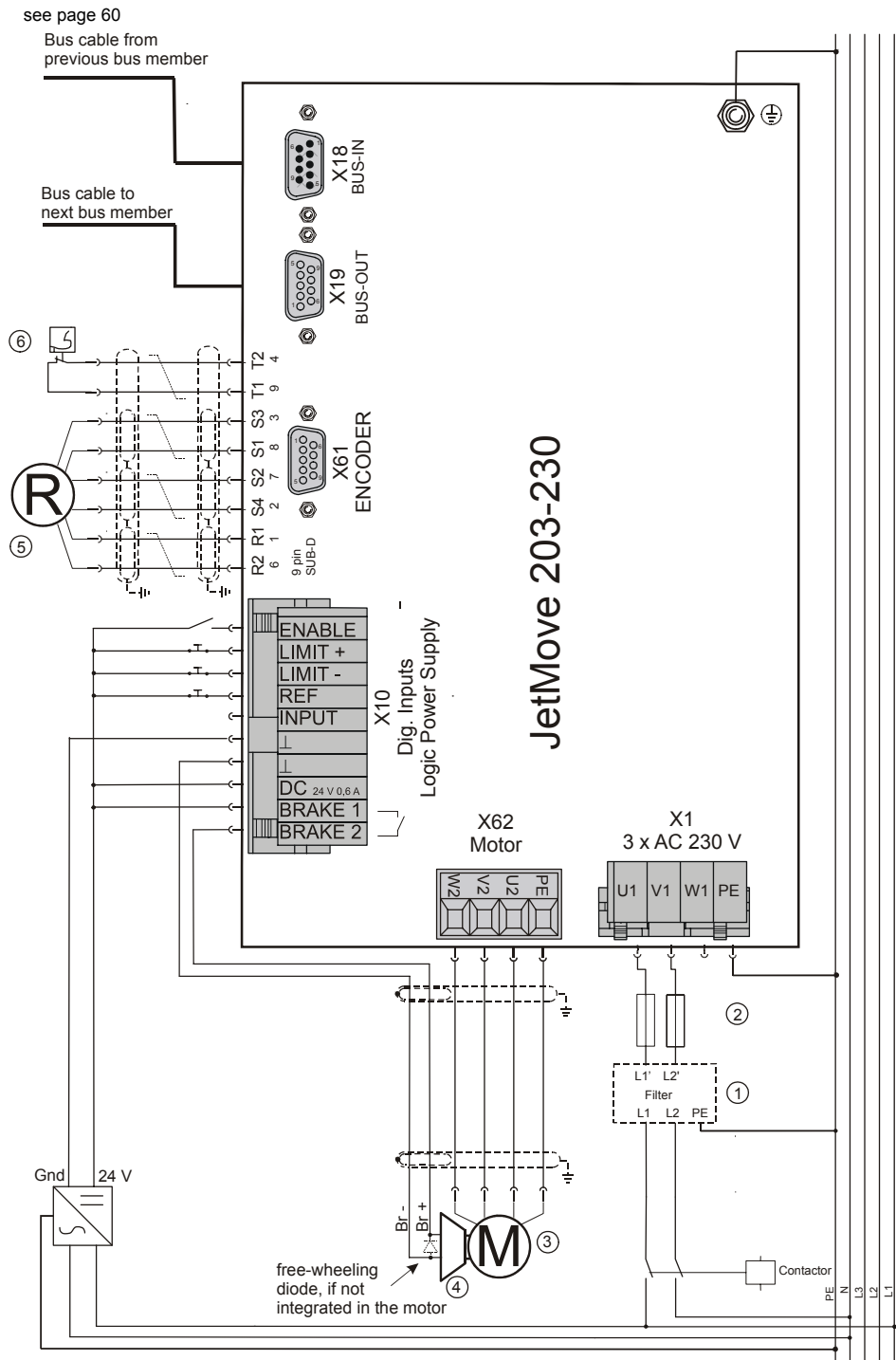
<b>Error Message Table JetMove 203-230</b>				
<b>Error Number</b>	<b>Type of Error</b>	<b>Description</b>	<b>Effect</b>	<b>Error Correction</b>
<b>F30</b>	I <sup>2</sup> t Error	The average power loss of the motor was more than the max. value configured by nominal motor current, overload factor and motor time constant See "I <sup>2</sup> t calculation" on page 39	– Immediate pulse disable	<ul style="list-style-type: none"> <li>– Let the motor cool down</li> <li>– Acknowledge failure</li> <li>– Check the configuration of nominal motor current, overload factor and motor time constant</li> <li>– Reduce the average load of the motor</li> </ul>
<b>F31</b>	Motor overload protection according to UL	The average motor power loss was higher than has been defined according to UL See chapter 5.2.3 "Motor overload calculation according to UL", page 41	– Immediate pulse disable	<ul style="list-style-type: none"> <li>– Let the motor cool down</li> <li>– Acknowledge failure</li> <li>– Reduce the average load of the motor</li> </ul>

## 9.2 WARNINGS

If the dot in the 7-segment display is flashing, one or several warnings have been recognized. Please check in the motion setup or by making enquiries in the PLC program which warning is active by means of the motion commands.



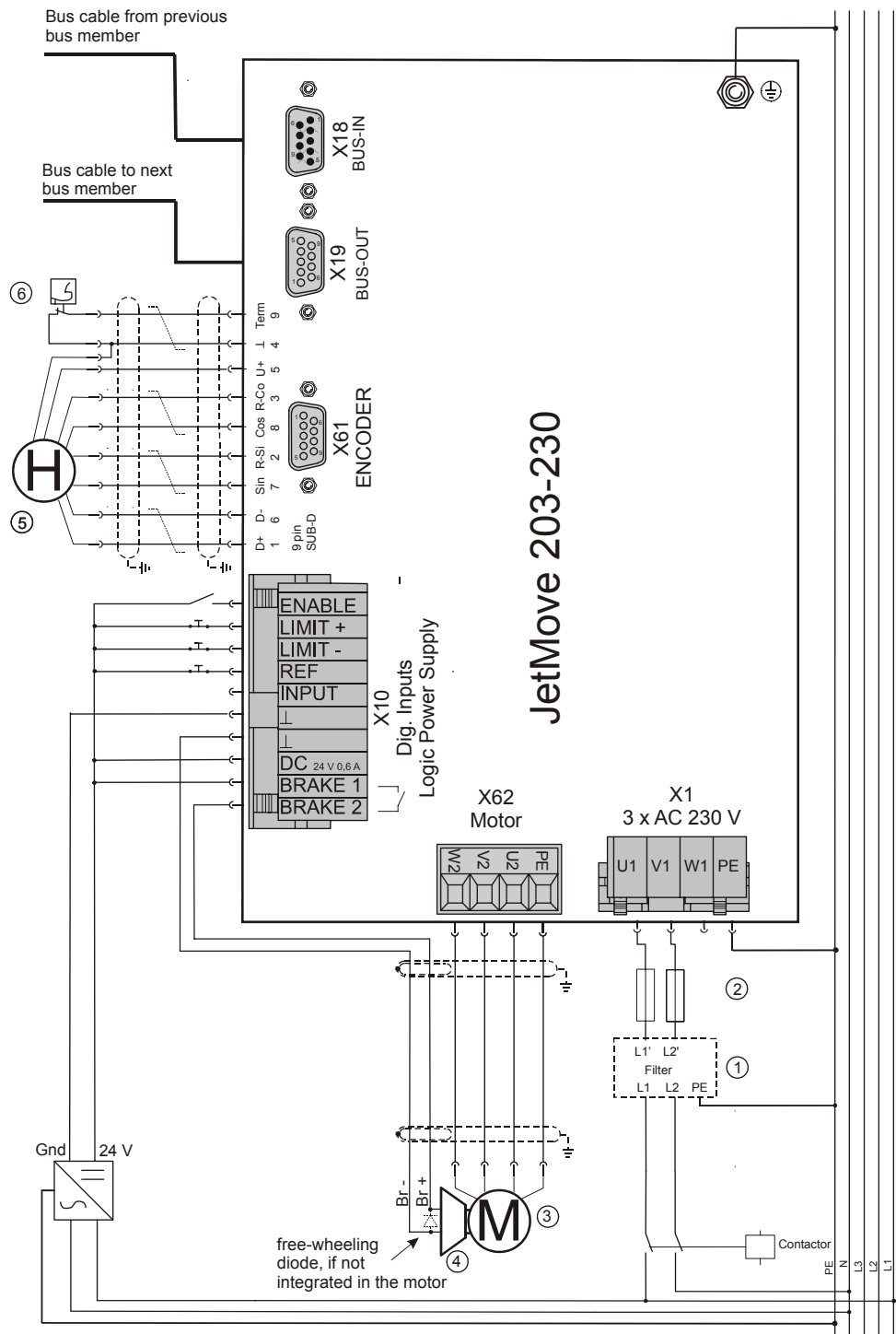
# 10 Wiring Diagrams



**Fig.13: Connection diagram JetMove 203-230, 1-phase connection, type of position transducer: resolver**

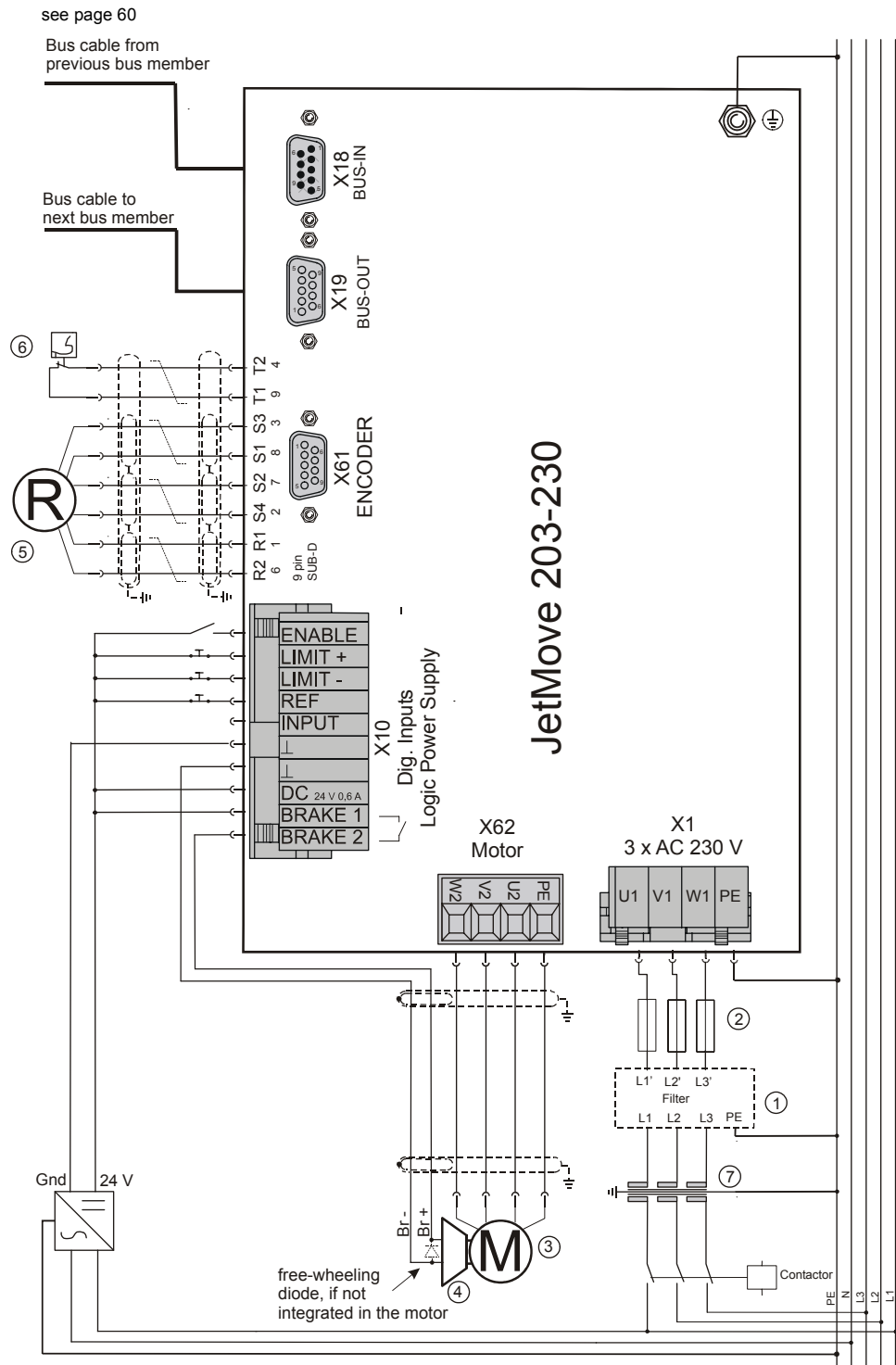
Also refer to chapter 7 "Description of Connections", page 45

see page 60

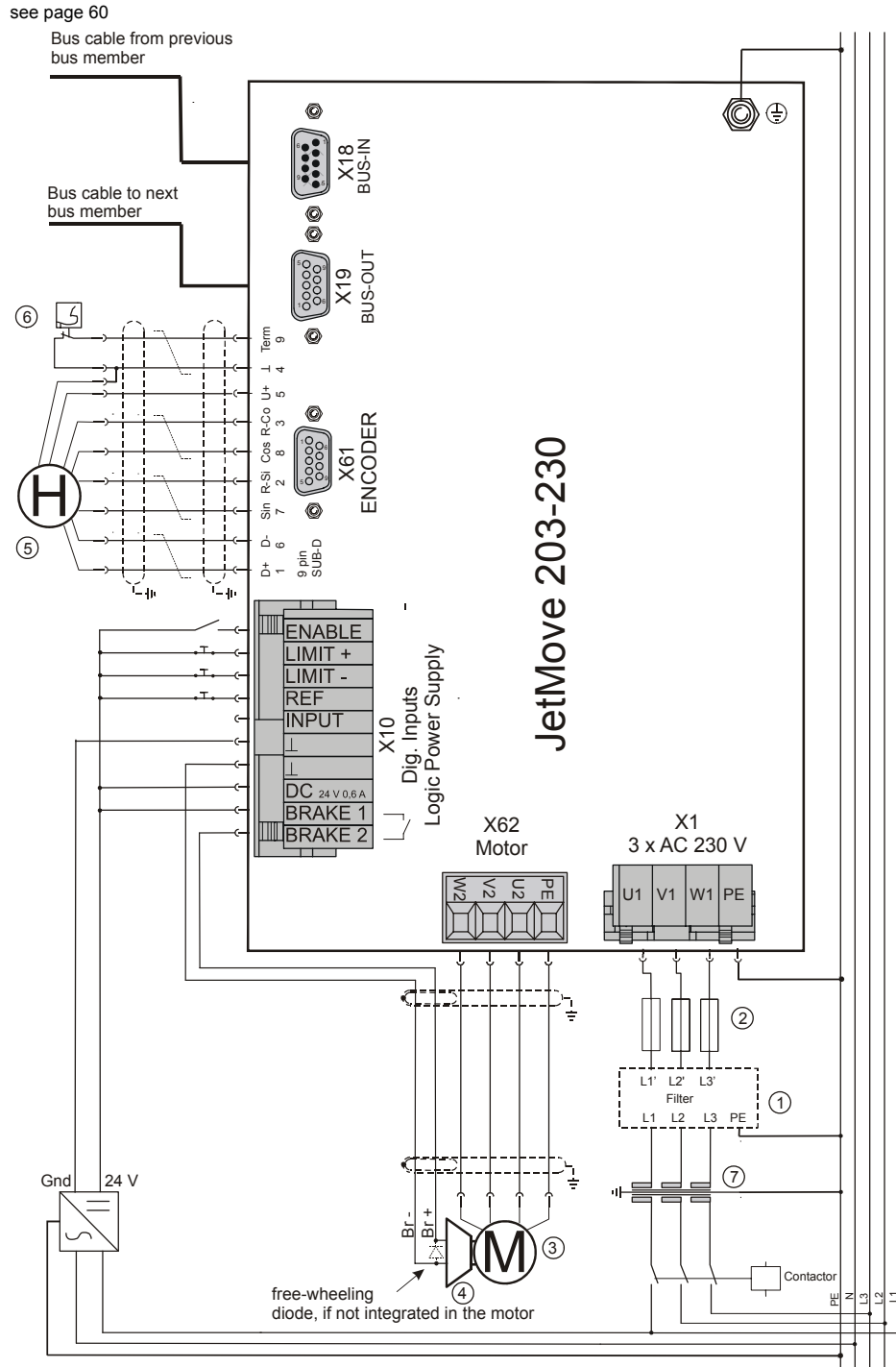


**Fig.14: Connection diagram JetMove 203-230, 1-phase connection, type of position transducer: HIPERFACE**





**Fig.15: Connection diagram JetMove 203-230, 3-phase connection, type of position transducer: resolver**



**Fig.16: Connection diagram JetMove 203-230, 3-phase connection, type of position transducer: HIPERFACE**

## Key to the Wiring Diagrams:

- 1 Line filter (optional) (refer to "Line filter" on page 36)
- 2 Overload protection of the mains cable (see "Overload protection" on page 35)
- 3 Motor
- 4 Motor brake (optional)
- 5 Position transducer (resolver or absolute encoder with HIPERFACE)
- 6 Motor-temperature protection
- 7 Isolating transformer or autotransformer



# 11 Analog Input (Option)

## 11.1 Function

For the JetMove 203-230, an optional integrated analog input card can be ordered. This card supplies an analog input of a 12 bit resolution. The converted value of the analog voltage can be read via a register of the JetMove in the PLC program or processed by the firmware of the JetMove in an additional controller. This way it is possible for example, to realize a pressure control loop in which the motor controlled by the JetMove generates the pressure. A pressure sensor in the machine is connected to the analog input to deliver the actual pressure value for the control loop.

This option can only be ordered as an alternative to the Ethernet connection (option OEM).

## 11.2 Technical Data

Technical Data of the Analog Input	
Connection	SUB-D-connector (male) at the device
Voltage range	0 - 10 V
Input current	1.4 mA max.
Resolution	12 bits
Value range	0 .. 32767 (resolution in steps of 8)
Electrical isolation	none
Accuracy	
Offset error	max. $\pm 5$ LSB ( $\pm 40$ values) correspond to $\pm 12.2$ mV
Gain error	max. $\pm 10$ LSB ( $\pm 80$ values) correspond to $\pm 24.4$ mV

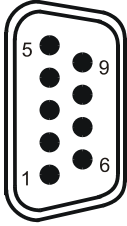
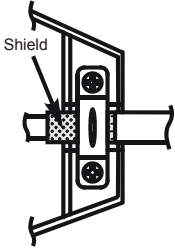
## 11.3 Description of Connections

### Specification of the connector for terminal X72

- 9-pin female SUB-D connector
- Metallised enclosure

### Specification of the cable for the analog input

- Cable size: min. 2\* 0.14 mm<sup>2</sup>
- Cores have to be twisted and shielded
- The shield must be connected to the connector housings on both ends of the cable with the greatest possible surface area.
- Material: Copper
- Temperature class: 60 °C

Pin Occupation of the Analog Input	
	<b>Shielding</b>
	
<b>X72</b>	Connect shield with the greatest possible surface area! Metallized enclosure necessary!
<b>Pin</b>	<b>Signal</b>
1	Analog signal (0 - 10 V to pin 6)
6 - 9	Analog GND (connected to earth in device)
2 - 5	Keep unoccupied

# Appendices





## Appendix A: Recent Revisions

Chapter	Comment	Revised	Added	Deleted
Introduction	Revision History		✓	
	Description of Symbols		✓	
Chapter 1	Usage as Agreed Upon	✓		
	Who is Permitted to Operate ...	✓		
	Modifications to the device		✓	
	Repair and maintenance	✓		
	Decommissioning and disposing of	✓		
	Description of symbols			✓
	For your own safety	✓		
	Residual dangers	✓		
	Instructions on EMI	✓		
Chapter 2	Mechanical installation	✓		
	Electrical installation	✓		
	Safety instructions for installing and commissioning	✓		
Chapter 3	Detailed description of the operating conditions and the respective standards	✓		
Chapter 5	Requirements to the power supply network in detail	✓		
	Important remarks on the time between switching off and on again		✓	
	Important remarks on activating the PFC fusing			✓
	Particulars on continuous power		✓	
	Motor overload protection		✓	
	Value of the internal ballast resistor	✓		

Chapter	Comment	Revised	Added	Deleted
	Braking relay: Particulars on the voltage potential		✓	
Chapter 7	Much more detailed description of connections and connection cables	✓		
Chapter 8	Significance of the seven-segment display in normal operation	✓		
Chapter 9	Error table	✓	✓	
Chapter 10	Wiring diagrams HIPERFACE connection Cascaded arrangement	✓	✓	✓
Chapter 11	Analog input (option)		✓	
Appendix	Recent revisions Glossary List of abbreviations (now in the glossary)	✓	✓ ✓	✓
Addresses	Addresses	✓		

## Appendix B: Glossary

AC	<b>Alternating Current:</b> Alternating Current
CE	<b>Communautés Européennes</b> European Union
DC	<b>Direct Current:</b> Direct Current
DIN	<b>Deutsches Institut für Normung e.V.</b> = German Industry Standard
EU	<b>European Union</b>
EC Low Voltage Directive	To be considered when using electric devices of a rated voltage between 50 and 1,000 V AC and between 75 and 1,500 V DC.
Electro-Magnetic Compatibility (EMC)	Definition according to EMC regulations: "EMC is the ability of a device to function in a satisfactory way in electro-magnetic surroundings without causing electromagnetic disturbances itself, which would be unbearable for other devices in these surroundings."
EN	<b>Europäische Norm</b> , that is: European Standard
ESD	<b>Electro-Static Discharge</b>
Hazard analysis	Extract from the 98/37/EC Safety of Machinery Directive: The manufacturer is under an obligation to assess the hazards in order to identify all of those which apply to his machine; he must then design and construct it taking account of his assessment.
HIPERFACE	<b>High Performance Interface</b> HIPERFACE designates a sensor-transducer system by Sick / Stegmann. The SinCos motor feedback system with the standardised HIPERFACE interface is often used in digital drive technology. Unlike the resolver, the SinCos motor feedback system with HIPERFACE interface contains electronic components. Over several motor rotations, a HIPERFACE will report the absolute position values; this cannot be performed by a resolver. A HIPERFACE is far more precise than a resolver, but also more expensive.
IEC	<b>International Electrotechnical Commission</b>
IP	<b>International Protection</b>
JetMove	JetMove is the product designation of a digital servo amplifier series produced by Jetter AG. e.g. JetMove 203-230 with <ul style="list-style-type: none"> <li>– 203 identifies a rated current of 3 A;</li> <li>– 230 identifies the operating voltage of the rated power supply</li> </ul>

Jetter system bus	The Jetter system bus is a system-bus system of a cable length of 200 m max. , and of fast data transmission rates of 1 Mbit/s. In addition to this, the Jetter system bus is highly immune to interferences. Therefore, the Jetter system bus is suited to realise field bus applications in a limited space.
JetWeb	Control technology comprising control systems, motion systems, user interfaces, visualization devices, remote I/Os and industrial PCs. Programming by means of multitasking and a modern sequence-oriented language. Communication by means of Ethernet TCP/IP and making use of the Web technologies.
Motor circuit-breaker	A circuit-breaker with monitoring functions of phases and temperature of a motor.
sea level	<b>Normal Null = Sea Level</b>
PE	<b>Protective Earth:</b> "Protective Earth", respectively "Protective Earth Conductor"
Resolver	Feedback unit at a servo motor for determining the absolute position within one revolution. Other than a HIPERFACE, the resolver will not provide any information on how many revolutions the motor has performed so far. A resolver could be envisaged as a transformer; the couplings of its secondary windings (sine and cosine) change in relation to the position of the motor shaft. Basically, a resolver consists of a rotor with one coil (primary) and a stator with two coils (secondary). The stator windings are displaced by 90° (sine and cosine). The resolver itself does not contain any electronic components.
SELV	<b>Safe Extra Low Voltage:</b> Voltage, which, under all operating conditions will not exceed a peak or DC voltage of 42.4 V. This voltage is either measured between two conductors or between one conductor and earth. The circuit, in which this voltage occurs, must be separated from the mains power supply by a safety isolating transformer or some equivalent.
SUB-D	Type name of a plug-in connector
$t_r/t_h$	<b>time rise / time hold:</b> "rise time of a pulse / total hold time of a pulse"
$t_r/t_n$	<b>time rise/time normal:</b> "rise time of a pulse / total duration of a pulse"
TN network	Supply network which is solidly earthed in the neutral point and which is equipped with a protective earth conductor.

TT network	Supply network which is solidly earthed in the neutral point, yet, which is not equipped with a protective earth conductor. Earthing is carried out by means of a local protective earth.
UL	Underwriters Laboratories Inc.
VDE	Verband Deutscher Elektrotechniker e.V. = Registered German Association of Electrical Engineers
DC link voltage	DC circuit within a servo drive on the basis of which the motor currents are generated.

**Units:**

A	Ampere
mA	Milliampere (1 mA = 10 <sup>-3</sup> A)
dB	Decibel
g	Gram
h	Hour
Hz	Hertz
K	kelvin
m	Meter
cm	Centimeter (1 cm = 10 <sup>-2</sup> m)
mm	Millimeter (1 mm = 10 <sup>-3</sup> m)
s	second
V	Volt
μV	Microvolt (1 μV = 10 <sup>-6</sup> V)
W	Watt
Ω	Ohm
°C	degrees centigrade (temperature unit)
°	Degrees (angular dimension)

## Appendix C: List of Illustrations

Fig. 1:	Double earthing	14
Fig. 2:	Shielding of SUB-D connectors in conformity with EMC standards.	19
Fig. 3:	EMC-conformous shielding for terminal screws	20
Fig. 4:	Rear and front view of the enclosure with mounting holes	23
Fig. 5:	Mounting dimensions of the JetMove 203-230	33
Fig. 6:	Block diagram of drive controller structure	43
Fig. 7:	Connection of the 3-phase supply line	45
Fig. 8:	Connection of the 1-phase supply line	46
Fig. 9:	Connection of motor lines	48
Fig. 10:	View on the SC series mating connector of the motor (internal thread M23)	49
Fig. 11:	Viewing the RC series mating connector of the resolver (internal thread M23)	53
Fig. 12:	RC series HIPERFACE mating connector (internal thread M23)	56
Fig. 13:	Connection diagram JetMove 203-230, 1-phase connection, type of position transducer: resolver	71
Fig. 14:	Connection diagram JetMove 203-230, 1-phase connection, type of position transducer: HIPERFACE	72
Fig. 15:	Connection diagram JetMove 203-230, 3-phase connection, type of position transducer: resolver	73
Fig. 16:	Connection diagram JetMove 203-230, 3-phase connection, type of position transducer: HIPERFACE	74

## Appendix D: Index

### Numerics

7-segment display	
Mode 0 - normal operation	63
Mode 1 - Commissioning	64

### A

Accessories	21
Active cooling	37
Analogue Input (Option)	77
Autotransformer	75

### B

Blocking of the motor	47
-----------------------	----

### C

Commissioning	
Safety Instructions	26
Compatible servo motors	39
Confection	22
Connection diagram	71
Contact assignment	
Power Supply	45, 46

### D

Description of symbols	5
Dimensions	33
Disposing	11
Drive Controller Specification	44

### E

Earthing procedure	13
Earth-leakage current breaker	14
Electrical specification	35
Error message table JetMove 2xx-xxx	65

### H

HIPERFACE cable	
Cable confection # 723	57

### I

Immunity to Interference	18
Information signs	12
Installation	
Electrical	24
Mechanical	22
Safety Instructions	25
Instructions on EMI	24

### L

Leakage current	13
LEDs at JetMove 2xx-xxx	63
Line filter	36

### M

Malfunctions	12, 47
Modifications	10
Motor power cable	
Cable confection # 24.1	51
Cable confection # 26.1	50
Motor protection	39
Motor winding isolation	24
Mounting direction	22

### N

Notes on EMI	18
--------------	----

### O

Operating parameters	
Connected load	27
Electrical Safety	29
EMI	
Emitted Interference	29
Interference Immunity	30
Environment	27
Mechanical Parameters	28
Oscillating of the motor	47

### P

Physical Dimensions	33
PWM Frequency	44

<b>Q</b>		Sine-consine sensor	44
Qualified staff	10	System bus cable	
		Cable confection # 530	61
		Specification	60
<b>R</b>			
Reference variables	58	<b>T</b>	
Repairs	10	Technical Data	35
Residual danger		Terminal box of the motor	52
Electric shock	17, 25, 26, 38		
High operating voltage	15	<b>U</b>	
Hot surfaces	15	Usage as Agreed Upon	9
Mech. force	16	Usage other than agreed upon	9
Potentially explosive atmosphere	16		
Resolver cable		<b>W</b>	
Cable confection # 23	54	Warnings	69
<b>S</b>		Wiring diagram	71
scope of delivery	21	Wiring diagrams	71
Servicing	10		







## **Jetter AG**

Gräterstraße 2  
D-71642 Ludwigsburg

### **Germany**

Phone: +49 7141 2550-0  
Sales: +49 7141 2550-433  
Telefax  
Sales: +49 7141 2550-484  
Hotline: +49 7141 2550-444  
Internet: <http://www.jetter.de>  
E-Mail: [sales@jetter.de](mailto:sales@jetter.de)

## **Jetter Subsidiaries**

### **Jetter Asia Pte. Ltd.**

32 Ang Mo Kio Industrial Park 2  
#05-02 Sing Industrial Complex  
Singapore 569510

#### **Singapore**

Phone: +65 6483 8200  
Fax: +65 6483 3881  
E-Mail: [sales@jetter.com.sg](mailto:sales@jetter.com.sg)  
Internet: <http://www.jetter.com.sg>

### **Jetter (Schweiz) AG**

Münchwilerstraße 19  
CH-9554 Täggerschen

#### **Switzerland**

Phone: +41 719 1879-50  
Fax: +41 719 1879-69  
E-Mail: [info@jetterag.ch](mailto:info@jetterag.ch)  
Internet: <http://www.jetterag.ch>

### **Jetter USA Inc.**

165 Ken Mar Industrial Parkway  
Broadview Heights  
OH 44147-2950

#### **U.S.A.**

Phone: +1 440 8380860  
Fax: +1 440 8380861  
E-Mail: [bschulze@jetterus.com](mailto:bschulze@jetterus.com)  
Internet: <http://www.jetterus.com>