

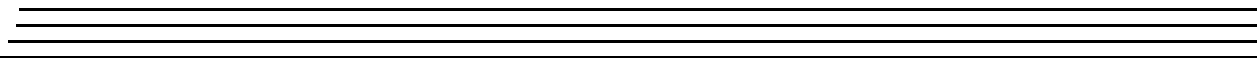

UM-22058-L

DT9832 Series User's Manual

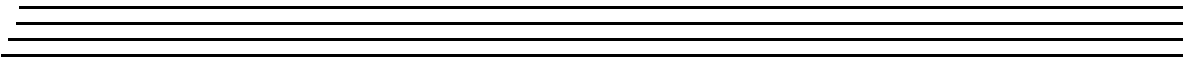
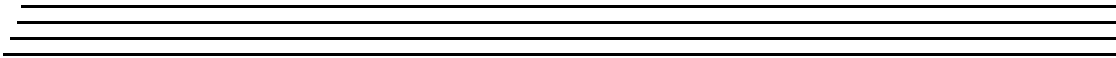

**Eleventh Edition
December, 2009**

**Copyright © 2006-2009 by Data Translation,
Inc.**

All rights reserved.

Information furnished by Data Translation, Inc. is believed to be accurate and reliable; however, no responsibility is assumed by Data Translation, Inc. for its use; nor for any infringements of patents or other rights of third parties which may result from its use. No license is granted by implication or otherwise under any patent rights of Data Translation, Inc.

Use, duplication, or disclosure by the United States Government is subject to restrictions as set forth in subparagraph (c)(1)(ii) of the Rights in Technical Data and Computer software clause at 48 C.F.R. 252.227-7013, or in subparagraph (c)(2) of the Commercial computer Software - Registered Rights clause at 48 C.F.R., 52-227-19 as applicable. Data Translation, Inc., 100 Locke Drive, Marlboro, MA 01752

Data Translation® is a registered trademark of Data Translation, Inc. DT-Open Layers™, DT-Open Layers for .NET Class Library™, DataAcq SDK™, Data Acquisition OMNI CD™, LV-Link™, and DTx-EZ™ are trademarks of Data Translation, Inc.

All other brand and product names are trademarks or registered trademarks of their respective companies.

Data Translation, Inc.
100 Locke Drive
Marlboro, MA 01752-1192
(800) 525-8528
www.datatranslation.com
Fax: (508) 481-8620
E-mail: info@datx.com

Radio and Television Interference

This equipment has been tested and found to comply with CISPR EN55022 Class A and EN61000-6-1 requirements and also with the limits for a Class A digital device, pursuant to Part 15 of the FCC Rules. These limits are designed to provide reasonable protection against harmful interference when the equipment is operated in a commercial environment. This equipment generates, uses, and can radiate radio frequency energy and, if not installed and used in accordance with the instruction manual, may cause harmful interference to radio communications. Operation of this equipment in a residential area is likely to cause harmful interference, in which case the user will be required to correct the interference at his own expense.

Changes or modifications to this equipment not expressly approved by Data Translation could void your authority to operate the equipment under Part 15 of the FCC Rules.

Note: This product was verified to meet FCC requirements under test conditions that included use of shielded cables and connectors between system components. It is important that you use shielded cables and connectors to reduce the possibility of causing interference to radio, television, and other electronic devices.

Canadian Department of Communications Statement

This digital apparatus does not exceed the Class A limits for radio noise emissions from digital apparatus set out in the Radio Interference Regulations of the Canadian Department of Communications.

Le présent appareil numérique n'émet pas de bruits radioélectriques dépassant les limites applicables aux appareils numériques de la class A prescrites dans le Règlement sur le brouillage radioélectrique édicté par le Ministère des Communications du Canada.

Table of Contents

About this Manual	11
Intended Audience.....	12
How this Manual is Organized	12
Conventions Used in this Manual	13
Related Information.....	14
Where To Get Help.....	15
Chapter 1: Overview	17
DT9832 Series Hardware Features	18
Supported Software.....	21
Accessories	23
Getting Started Procedure.....	24
Part 1: Getting Started	25
Chapter 2: Setting Up and Installing the Module	27
Unpacking.....	29
Applying Power to the Module	30
Attaching Modules to the Computer	31
Connecting Directly to the USB Ports	32
Connecting to an Expansion Hub	33
Configuring the DT9832 Series Device Driver	36
Chapter 3: Wiring Signals to the BNC Connection Box . . .	37
Preparing to Wire Signals	39
Wiring Recommendations	39
High-Performance Considerations	40

Wiring to the BNC Box	40
Wiring Signals to the BNC Connectors	42
Wiring Signals to the D-Sub Connectors	43
Digital In/Out Connector	44
CT/Enc In, Analog Out, Clk/Trig Connector	45
Connecting Analog Input Signals	47
Connecting Analog Output Signals	48
Connecting Digital I/O Signals	49
Connecting Counter/Timer Signals	50
Event Counting	50
Up/Down Counting	52
Frequency Measurement	53
Period/Pulse Width Measurement	53
Edge-to-Edge Measurement	54
Continuous Edge-to-Edge Measurement	55
Pulse Output	56
Connecting Quadrature Decoder Signals.....	58
Chapter 4: Verifying the Operation of a Module	59
Installing the Quick DataAcq Application	61
Running the Quick DataAcq Application	61
Testing Single-Value Analog Input	62
Testing Single-Value Analog Output	63
Testing Continuous Analog Input	64
Testing Single-Value Digital Input	65
Testing Single-Value Digital Output	66
Testing Frequency Measurement	67
Testing Pulse Output	68

Part 2: Using Your Module	69
Chapter 5: Principles of Operation	71
Analog Input Features	73
Input Resolution	73
Analog Input Channels	73
Specifying a Single Analog Input Channel	74
Specifying One or More Analog Input Channels	74
Specifying the Digital Input Port in the Analog Input Channel List	75
Specifying Counter/Timers in the Analog Input Channel List	75
Specifying Quadrature Decoders in the Analog Input Channel List	76
Input Ranges	78
Input Sample Clock Sources	78
Analog Input Conversion Modes	79
Single-Value Mode	79
Continuous Scan Mode	79
Input Triggers	81
Data Format and Transfer	82
Error Conditions	83
Analog Output Features	84
Output Resolution	84
Analog Output Channels	84
Specifying a Single Analog Output Channel	85
Specifying Multiple Analog Output Channels and/or the Digital Output Port	85
Output Ranges and Gains	86
Output Triggers.....	86
Output Clocks	87

- Output Conversion Modes 87
 - Streaming Analog Output 88
 - Waveform Generation 89
- Data Format and Transfer 90
- Error Conditions 91
- Digital I/O Features..... 92
 - Digital I/O Lines 92
 - Operation Modes 93
- Counter/Timer Features 95
 - C/T Channels 95
 - C/T Clock Sources 96
 - Gate Types 97
 - Pulse Output Types and Duty Cycles 98
 - Counter/Timer Operation Modes 99
 - Event Counting 100
 - Up/Down Counting 100
 - Frequency Measurement 101
 - Edge-to-Edge Measurement 102
 - Continuous Edge-to-Edge Measurement 104
 - Rate Generation 105
 - One-Shot 106
 - Repetitive One-Shot 107
- Quadrature Decoder Features 109
- Chapter 6: Supported Device Driver Capabilities..... 113**
 - Data Flow and Operation Options..... 115
 - Buffering 116
 - Triggered Scan Mode..... 117
 - Data Encoding..... 117
 - Channels 118

Gain	119
Ranges	119
Resolution	120
Thermocouple and RTD Support.....	120
IEPE Support.....	121
Triggers	122
Clocks.....	123
Counter/Timers	124
Chapter 7: Troubleshooting	127
General Checklist	128
Technical Support	132
If Your Module Needs Factory Service	133
Chapter 8: Calibration	135
Using the Calibration Utility	137
Calibrating the Analog Input Subsystem	138
Connecting a Precision Voltage Source	138
Using the Auto-Calibration Procedure	138
Using the Manual Calibration Procedure	139
Calibrating the Analog Output Subsystem	141
Appendix A: Specifications	143
Appendix B: Connector Pin Assignments	157
OEM Version Connectors	158
OEM J2 Connector	159
OEM J3 Connector	161
OEM Wiring Methods	163
OEM TB1 Connector.....	164
BNC Box Connectors	165
Digital I/O Connector	165

CT/Enc In, Analog Out, Clk/Trig Connector	167
EP353 Accessory Panel Connectors	169
Connector J1	169
Connector J2	171
EP356 Accessory Panel Connectors	173
Connector J1	174
Connector J2	175
EP355 Screw Terminal Assignments	177
Appendix C: Ground, Power, and Isolation	179
Secondary Power Connector	180
Ground, Power, and Isolation Connections	181
Index	183

About this Manual

The first part of this manual describes how to install and set up your DT9832 Series module and device driver, and verify that your module is working properly.

The second part of this manual describes the features of the DT9832 Series modules, the capabilities of the DT9832 Series Device Driver, and how to program the DT9832 Series board using DT-Open Layers for .NET Class Library™ software. Troubleshooting information is also provided.

Note: For information on checking system requirements, installing the software, and viewing the documentation, refer to the README file on the OMNI CD.

For more information on the class library, refer to the *DT-Open Layers for .NET Class Library User's Manual*. If you are using the DataAcq SDK or a software application to program your device, refer to the documentation for that software for more information.

Note: This manual refers to the DT9832 and DT9832A modules collectively as the DT9832 Series, except where their features differ.

The DT9832 Series module is available either installed in a metal BNC connection box, or as a board-level OEM version that you can install in your own custom application. If the information in this manual applies to both versions of the DT9832 Series module, the manual uses the product name "DT9832 Series module." Otherwise, the specific product name is used.

Intended Audience

This document is intended for engineers, scientists, technicians, or others responsible for installing, setting up, using, and/or programming DT9832 Series modules for data acquisition operations.

It is assumed that you are familiar with the requirements of your application. It is also assumed that you have some familiarity with data acquisition principles, that you understand your application, and that you are familiar with the Microsoft® Windows® XP, Windows Vista®, or Windows 7 operating system.

How this Manual is Organized

This manual is organized as follows:

- [Chapter 1, “Overview,”](#) describes the major features of the DT9832 Series module, as well as the supported software and accessories for the modules.
- [Chapter 2, “Setting Up and Installing the Module,”](#) describes how to install a module, how to apply power to the module, and how to configure the device driver.
- [Chapter 3, “Wiring Signals to the BNC Connection Box,”](#) describes how to wire signals to a DT9832 Series BNC connection box.
- [Chapter 4, “Verifying the Operation of a Module,”](#) describes how to verify the operation of the module with the Quick DataAcq application.
- [Chapter 5, “Principles of Operation,”](#) describes all of the features of the module and how to use them in your application.
- [Chapter 6, “Supported Device Driver Capabilities,”](#) lists the data acquisition subsystems and the associated features accessible using the DT9832 Series Device Driver.

- [Chapter 7, “Troubleshooting,”](#) provides information that you can use to resolve problems with the module and device driver, should they occur.
- [Chapter 8, “Calibration,”](#) describes how to calibrate the analog I/O circuitry of the module.
- [Appendix A, “Specifications,”](#) lists the specifications of the DT9832 Series modules.
- [Appendix B, “Connector Pin Assignments,”](#) shows the pin assignments and describes how to wire signals to the OEM version of the DT9832 Series modules, using backplanes, accessory panels, and screw terminal panels.
- [Appendix C, “Ground, Power, and Isolation,”](#) describes the electrical characteristics of the DT9832 Series modules.
- An index completes this manual.

Conventions Used in this Manual

The following conventions are used in this manual:

- Notes provide useful information that requires special emphasis, cautions provide information to help you avoid losing data or damaging your equipment, and warnings provide information to help you avoid catastrophic damage to yourself or your equipment.
- Items that you select or type are shown in **bold**.
- Courier font is used to represent source code.

Related Information

Refer to the following documents for more information on using the DT9832 Series module:

- *Benefits of the Universal Serial Bus for Data Acquisition*. This white paper describes why USB is an attractive alternative for data acquisition. It is available on the Data Translation® web site (www.datatranslation.com).
- *Measure Foundry Manual* (UM-19298) and online help. These documents describe how to use Measure Foundry™ to build drag-and-drop test and measurement applications for Data Translation data acquisition devices.
- *DT-Open Layers for .NET User's Manual* (UM-22161). For programmers who are developing their own application programs using Visual C# or Visual Basic .NET, this manual describes how to use the DT-Open Layers for .NET Class Library to access the capabilities of Data Translation data acquisition devices.
- *DataAcq SDK User's Manual* (UM-18326). For programmers who are developing their own application programs using the Microsoft C compiler, this manual describes how to use the DT-Open Layers™ DataAcq SDK™ to access the capabilities of Data Translation data acquisition devices. This manual is included on the Data Acquisition OMNI CD.
- *DTx-EZ Getting Started Manual* (UM-15428). This manual describes how to use the ActiveX controls provided in DTx-EZ™ to access the capabilities of Data Translation data acquisition devices in Microsoft Visual Basic® or Visual C++®.
- *LV-Link Online Help*. This help file describes how to use LV-Link™ with the LabVIEW™ graphical programming language to access the capabilities of Data Translation data acquisition devices.

- *DAQ Adaptor for MATLAB (UM-22024)*. This document describes how to use Data Translation's DAQ Adaptor to provide an interface between the MATLAB Data Acquisition subsystem from The MathWorks and Data Translation's DT-Open Layers architecture.
- Microsoft Windows XP, Windows Vista, or Windows 7 documentation.
- USB web site (<http://www.usb.org>).

Where To Get Help

Should you run into problems installing or using a DT9832 Series module, our Technical Support Department is available to provide technical assistance. Refer to [Chapter 7](#) starting on [page 127](#) for information on how to contact the Technical Support Department. If you are outside the U.S. or Canada, call your local distributor, whose number is listed on Data Translation's web site (www.datatranslation.com).



Overview

DT9832 Series Hardware Features.....	18
Supported Software.....	21
Accessories.....	23
Getting Started Procedure.....	24

DT9832 Series Hardware Features

The DT9832 Series is a family of high-performance, multifunction data acquisition modules for the USB (Ver. 2.0 or Ver. 1.1) bus. The key hardware features of the DT9832 Series modules are as follows:

- Available either installed in a metal BNC connection box, or as a board-level OEM version that you can install in your own custom application.
- Simultaneous operation of analog input, analog output, digital I/O, and counter/timer subsystems.
- Analog input subsystem:
 - 16-bit A/D converters.
 - Throughput rate up to 1250 kSamples/s (DT9832) or 2000 kSamples/s (DT9832A).
 - Either 4 (DT9832) or 2 (DT9832A) single-ended separate, simultaneous analog input channels.
 - Input range of ± 10 V.
 - 13- or 15-location channel list. You can read the digital inputs, the two 32-bit counters, and the three 32-bit quadrature decoders using the A/D subsystem and the A/D clock. This synchronizes digital, counter, and quadrature decoder inputs with the analog measurements. The maximum sampling rate when using the channel list is 1250 kSamples/s (DT9832) or 2000 kSamples/s (DT9832A).
- Analog output subsystem:
 - Two 16-bit D/A converters (if your module supports analog output channels).
 - Output rate up to 500 kSamples/s per channel (simultaneous).
 - Output range of ± 10 V.

- The DACs are deglitched to prevent noise from interfering with the output signal.
- Output channel list. You can cycle through the output channel list using continuous output mode or waveform generation mode.
- Digital I/O subsystem:
 - One digital input port, consisting of 16 digital input lines. You can program any of the first eight digital input lines to perform interrupt-on-change operations. You can read the value of the digital input port using the analog input channel-gain list.
 - One digital output port, consisting of 16 digital output lines. You can output the value of the digital output port using the output channel list.
- Two 32-bit counter/timer (C/T) channels that perform event counting, up/down counting, frequency measurement, edge-to-edge measurement, continuous edge-to-edge measurement, continuous pulse output, one-shot, and repetitive one-shot operations. You can read the value of one or more of the C/T channels using the analog input channel list.
- Three 32-bit quadrature decoders that can provide relative or absolute position of quadrature encoder input and calculate rotational speed. You can read the value of one or more of the quadrature decoder channels using the analog input channel list.
- External or internal clock source.
- Trigger operations using a software command, an analog threshold value, or an external digital trigger.
- 500 V galvanic isolation barrier that prevents ground loops to maximize analog signal integrity and protect your computer.

The key differences among the DT9832 Series modules are summarized in [Table 1](#). Note that all modules provide 16 digital input lines, 16 digital output lines, 16-bit resolution, two counter/timers, three quadrature decoders, and a throughput rate of up to 1250 kSamples/s (DT9832) or 2000 kSamples/s (DT9832A).

Table 1: Summary of DT9832 Series Modules

Module	Analog Inputs	Analog Outputs	Packaging
DT9832-04-2-OEM	4 single-ended	2	OEM
DT9832-04-2-BNC	4 single-ended	2	BNC
DT9832-04-0-OEM	4 single-ended	0	OEM
DT9832-04-0-BNC	4 single-ended	0	BNC
DT9832A-02-2-OEM	2 single-ended	2	OEM
DT9832A-02-2-BNC	2 single-ended	2	BNC
DT9832A-02-0-OEM	2 single-ended	0	OEM
DT9832A-02-0-BNC	2 single-ended	0	BNC

Notes:

- *OEM* packaging refers to the board-level version; the power supply is not included.
- *BNC* packaging refers to a connection box with BNCs for the specified number of analog inputs, 2 BNCs for analog outputs (if included), 1 BNC for an external A/D clock, 1 BNC for an external DAC clock, 1 BNC for an external A/D trigger, and 1 BNC for an external DAC trigger.

Supported Software

The following software is available for use with the DT9832 Series modules and is on the Data Acquisition OMNI CD:

- **DT9832 Series Device Driver** – The device driver allows you to use a DT9832 Series module with any of the supported software packages or utilities. Refer to [page 36](#) for more information on configuring the device driver.
- **Quick DataAcq application** – The Quick DataAcq application provides a quick way to get up and running using a DT9832 Series module. Using this application, you can verify key features of the modules, display data on the screen, and save data to disk. Refer to [Chapter 4](#) starting on [page 59](#) for more information on using the Quick DataAcq application.
- **The quickDAQ application** – An evaluation version of this .NET application is included on the Data Acquisition OMNI CD. quickDAQ lets you acquire analog data from all devices supported by DT-Open Layers for .NET software at high speed, plot it during acquisition, analyze it, and/or save it to disk for later analysis.
- **Measure Foundry** – An evaluation version of this software is included or provided via a link on the Data Acquisition OMNI CD. Measure Foundry is a drag-and-drop test and measurement application builder designed to give you top performance with ease-of-use development. Order the full development version of this software package to develop your own application using real hardware.
- **DT-Open Layers for .NET Class Library** – Use this class library if you want to use Visual C# or Visual Basic for .NET to develop your own application software for a DT9832 Series module using Visual Studio 2003 or Visual Studio 2005; the class library complies with the DT-Open Layers standard.

- **DataAcq SDK** – Use the Data Acq SDK if you want to use Visual Studio 6.0 and Microsoft C or C++ to develop your own application software for a DT9832 Series module using Windows XP, Windows Vista, or Windows 7; the DataAcq SDK complies with the DT-Open Layers standard.
- **DTx-EZ** – DTx-EZ provides ActiveX controls, which allow you to access the capabilities of the DT9832 Series modules using Microsoft Visual Basic or Visual C++; DTx-EZ complies with the DT-Open Layers standard.
- **DAQ Adaptor for MATLAB** – Data Translation’s DAQ Adaptor provides an interface between the MATLAB Data Acquisition (DAQ) subsystem from The MathWorks and Data Translation’s DT-Open Layers architecture.
- **LV-Link** – An evaluation version of this software is included on the Data Acquisition OMNI CD. Use LV-Link if you want to use the LabVIEW graphical programming language to access the capabilities of Data Translation modules.

Refer to the Data Translation web site (www.datatranslation.com) for information about selecting the right software package for your needs.

Accessories

1

You can purchase the following optional items from Data Translation for use with the OEM version of the DT9832 Series module:

- **EP361** – +5V power supply and cable.
- **EP353** – Accessory panel that provides one 37-pin, D-sub connector for attaching analog input signals and one 26-pin connector for attaching a 5B Series signal conditioning backplane.
- **EP355** – Screw terminal panel that provides 14-position screw terminal blocks for attaching counter/timer, digital I/O, trigger, and clock signals. (Not for analog input use with this module.)
- **EP356** – Accessory panel that provides two 37-pin, D-sub connectors for attaching digital I/O, analog output, counter/timer, trigger, and clock signals.
- **EP333** – 2-meter shielded cable with two 37-pin connectors that connect an EP356 accessory panel to an STP37 screw terminal panel.
- **EP360** – 2-meter shielded cable with two 37-pin connectors that connect an EP353 accessory panel to an STP37 screw terminal panel.

Getting Started Procedure

The flow diagram shown in [Figure 1](#) illustrates the steps needed to get started using the DT9832 Series module. This diagram is repeated in each Getting Started chapter; the shaded area in the diagram shows you where you are in the procedure.

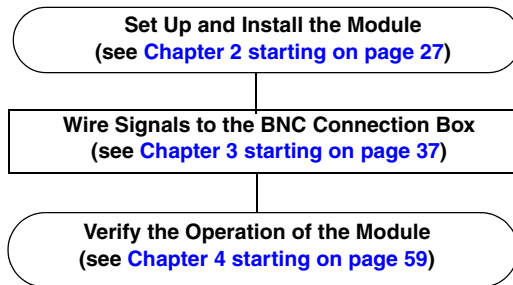

Figure 1: Getting Started Flow Diagram

Part 1:
Getting Started



Setting Up and Installing the Module

Unpacking	29
Applying Power to the Module	30
Attaching Modules to the Computer	31
Configuring the DT9832 Series Device Driver	36

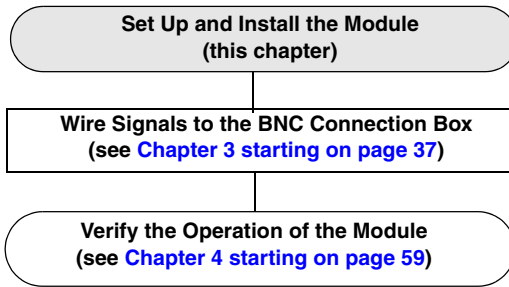

Note: The DT9832 Series module is factory-calibrated. If you decide that you want to recalibrate the analog input or analog output circuitry, refer to the instructions on [Chapter 8](#).

Unpacking

Open the shipping box and verify that the following items are present:

- BNC connection box or OEM version of the DT9832 Series module
- Data Acquisition OMNI CD

Note that if you purchased a BNC connection box, a USB cable and an EP361 power supply and power cable should also be included.

If an item is missing or damaged, contact Data Translation. If you are in the United States, call the Customer Service Department at (508) 481-3700, ext. 1323. An application engineer will guide you through the appropriate steps for replacing missing or damaged items. If you are located outside the United States, call your local distributor, listed on Data Translation's web site (www.datatranslation.com).

Applying Power to the Module

The BNC connection box is shipped with an EP361 +5V power supply and cable. For the OEM version of the DT9832 Series module, you must provide your own +5 V power source or purchase the EP361 power supply and cable from Data Translation.

To apply power to the module, do the following:

1. Connect the +5 V power supply to the power connector on the DT9832 Series module. Refer to [Figure 2](#).

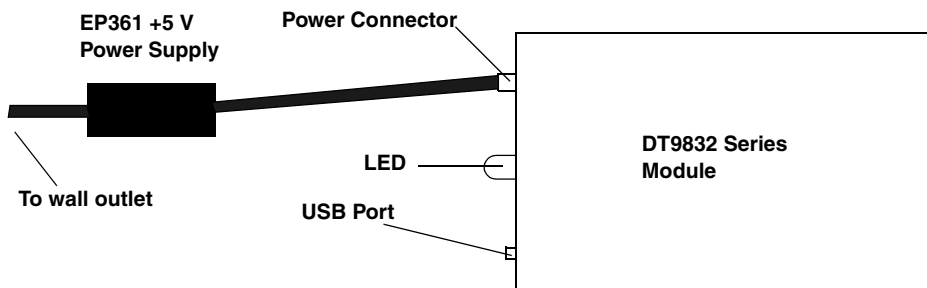

Figure 2: Attaching a +5 V Power Supply to the DT9832 Series Module

2. Plug the power supply into a wall outlet.

For more detailed information about ground, power, and isolation connections on a DT9832 Series module, refer to [Appendix C](#) starting on [page 179](#).

Attaching Modules to the Computer

This section describes how to attach DT9832 Series modules to the host computer.

Notes: Most computers have several USB ports that allow direct connection to USB devices. If your application requires more DT9832 Series modules than you have USB ports for, you can expand the number of USB devices attached to a single USB port by using expansion hubs. For more information, refer to [page 33](#).

You can unplug a module, then plug it in again, if you wish, without causing damage. This process is called hot-swapping. Your application may take a few seconds to recognize a module once it is plugged back in.

You must install the device driver before connecting your DT9832 Series module(s) to the host computer.

Connecting Directly to the USB Ports

To connect a DT9832 Series module directly to a USB port on your computer, do the following:

1. Make sure that you have attached a power supply to the module.
2. Attach one end of the USB cable to the USB port on the module.
3. Attach the other end of the USB cable to one of the USB ports on the host computer, as shown in [Figure 3](#).

The operating system automatically detects the USB module and starts the Found New Hardware wizard.

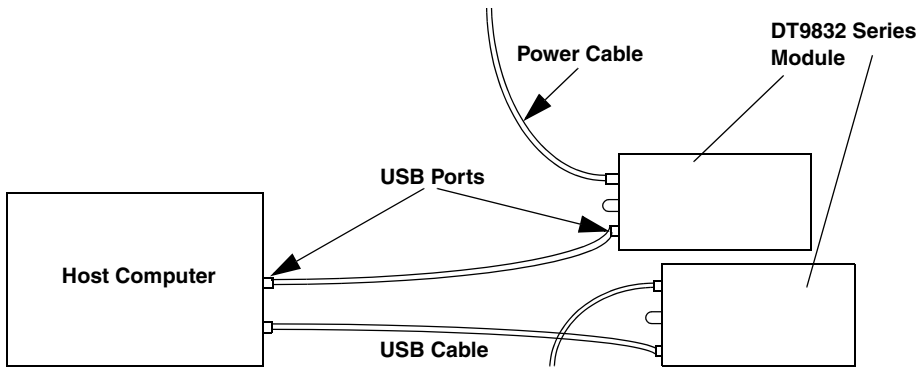

Figure 3: Attaching the Module to the Host Computer

4. For Windows Vista:
 - a. Click **Locate and install driver software (recommended)**.
The popup message "Windows needs your permission to continue" appears.
 - b. Click **Continue**.
The Windows Security dialog box appears.

- c. Click **Install this driver software anyway**.

The LED on the module turns green.

For Windows XP:

- a. Click **Next** and/or **Finish** as required in the wizard.
Once the firmware is loaded, the wizard restarts to initiate the firmware to accept commands.
- b. Click **Next** and/or **Finish** again.
The LED on the module turns green.

Note: Windows 7 finds the device automatically.

5. Repeat these steps to attach another DT9832 Series module to the host computer, if desired.

Connecting to an Expansion Hub

Expansion hubs are powered by their own external power supply. The practical number of DT9832 Series modules that you can connect to a single USB port depends on the throughput you want to achieve.

To connect multiple DT9832 Series modules to an expansion hub, do the following:

1. Make sure that you have attached a power supply to the module.
2. Attach one end of the USB cable to the module and the other end of the USB cable to an expansion hub.
3. Connect the power supply for the expansion hub to an external power supply.
4. Connect the expansion hub to the USB port on the host computer using another USB cable.

The operating system automatically detects the USB module and starts the Found New Hardware wizard.

5. For Windows Vista:

- a. Click **Locate and install driver software (recommended)**.
The popup message "Windows needs your permission to continue" appears.
- b. Click **Continue**.
The Windows Security dialog box appears.
- c. Click **Install this driver software anyway**.
The LED on the module turns green.

For Windows XP:

- a. Click **Next** and/or **Finish** as required in the wizard.
Once the firmware is loaded, the wizard restarts to initiate the firmware to accept commands.
- b. Click **Next** and/or **Finish** again.
The LED on the module turns green.

Note: Windows 7 finds the device automatically.

6. Repeat these steps until you have attached the number of expansion hubs and modules that you require. Refer to [Figure 4](#).
The operating system automatically detects the USB devices as they are installed.

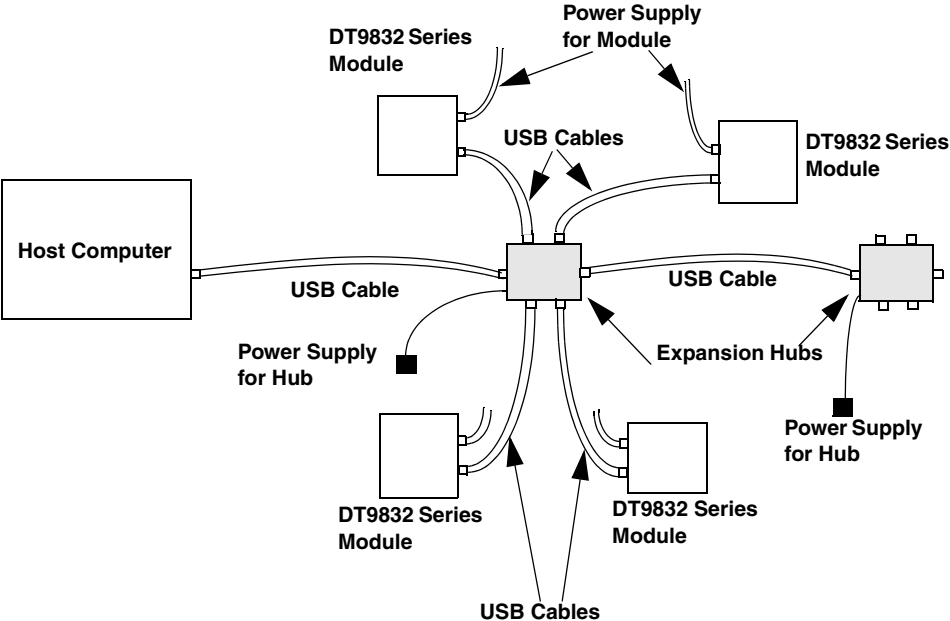

Figure 4: Attaching Multiple Modules Using Expansion Hubs

Configuring the DT9832 Series Device Driver

To configure the device driver for the DT9832 Series module, do the following:

1. If you have not already done so, power up the host computer and all peripherals.
2. From the Windows Start menu, select **Settings | Control Panel**.
3. From the Control Panel, double-click **Open Layers Control Panel**.
The Data Acquisition Control Panel dialog box appears.
4. Click the DT9832 Series module that you want to configure, and then click **Advanced**.
The Configurable Board Options dialog box appears.
5. If required, select the digital input line(s) that you want to use for interrupt-on-change operations. When any of the selected lines changes state, the module reads the entire 16-bit digital input value and generates an interrupt.
6. Click **OK**.
7. If you want to rename the module, click **Edit Name**, enter a new name for the module, and then click **OK**. The name is used to identify the module in all subsequent applications.
8. Repeat steps 4 to 7 for the other modules that you want to configure.
9. When you are finished configuring the modules, click **Close**.

Continue with the instructions on wiring in [Chapter 3](#).



Wiring Signals to the BNC Connection Box

Preparing to Wire Signals	39
Connecting Analog Input Signals	47
Connecting Analog Output Signals.....	48
Connecting Digital I/O Signals	49
Connecting Counter/Timer Signals	50
Connecting Quadrature Decoder Signals.....	58

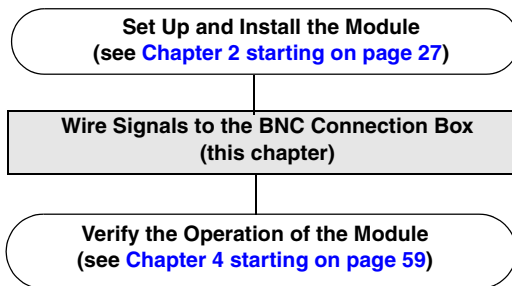

Preparing to Wire Signals

This section provides recommendations and information about wiring signals to the BNC connection box.

Note: If you are using the D-sub connectors on the BNC box or the OEM version of the DT9832 Series module, use this chapter for conceptual information, and then refer to [Appendix B](#) starting on [page 157](#) for connector pin assignments and accessory panel information.

3

Wiring Recommendations

Keep the following recommendations in mind when wiring signals to a BNC connection box:

- Follow standard ESD procedures when wiring signals to the module.
- Separate power and signal lines by using physically different wiring paths or conduits.
- To avoid noise, do not locate the box and cabling next to sources that produce high electromagnetic fields, such as large electric motors, power lines, solenoids, and electric arcs, unless the signals are enclosed in a mumetal shield.
- Prevent electrostatic discharge to the I/O while the box is operational.
- Connect all unused analog input channels to analog ground.

High-Performance Considerations

Cables have a characteristic impedance, which can add amplitude and phase errors to signals (typically 1/2 LSB at 10 kHz for a 6-foot cable) due to reflection, if the impedance is unmatched on both ends of a connection. For meticulous applications where optimal performance is required, do the following:

- Pay attention to cable matching from the source to the DT9832 module and between channels.
- Consider placing a resistor with the same impedance in series with the cable at your source.
- Alternatively, add termination with matched impedance at the module. Typically this is a 100 ohm resistor in series with a 1000 pF NPO capacitor to common. At higher frequencies the cable will see the 100 ohms. Note the component tolerances and the effect they will have on simultaneous sampling across all eight channels.

Wiring to the BNC Box

The BNC connection box contains both BNC connectors and 37-pin, D-sub connectors. An example of a BNC connection box is shown in [Figure 5](#).

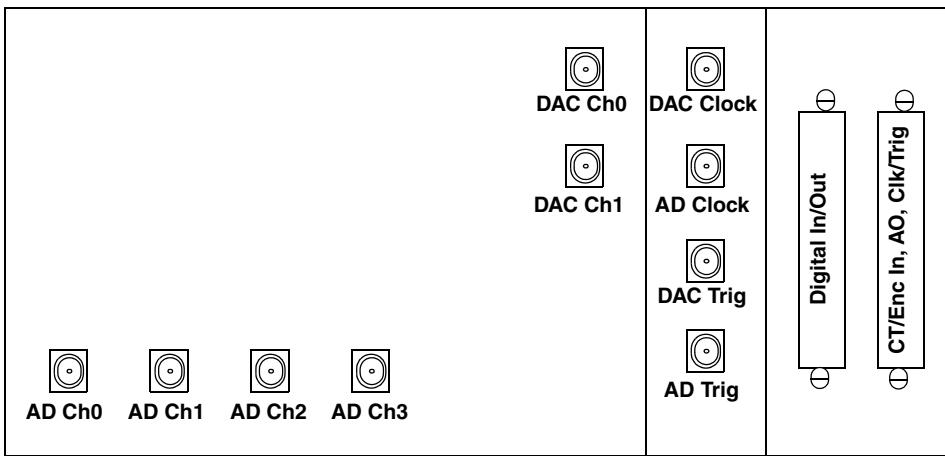

Figure 5: DT9832-04-2-BNC Version of the BNC Connection Box

You can wire signals to the BNC connection box as follows. Refer to [Appendix A](#) starting on [page 143](#) for information about the required D-sub mating connectors if you choose to use the D-sub connectors.

- **Analog input signals** – You can wire analog input signals using the BNC connectors labelled AD Ch0 to AD Ch3.
- **Analog output signals** – You can wire analog output signals (if your DT9832 model supports them) in one of the following ways:
 - Using the BNC connectors labelled DAC Ch0 and DAC Ch1.
 - Using the appropriate pins on the CT/Enc In, Analog Out, Clk/Trig connector. You can access the pins by building your own cable/panel. Refer to [page 45](#) for connector pin assignments.
- **Digital I/O signals** – To wire digital I/O signals, you must use the appropriate pins on the Digital I/O connector. You can access the pins by building your own cable/panel. Refer to [page 44](#) for connector pin assignments.

- **Counter/timer signals** – To wire counter/timer signals, you must use the appropriate pins on the CT/Enc In, Analog Out, Clk/Trig connector. You can access the pins by building your own cable/panel. Refer to [page 45](#) for connector pin assignments.
- **External A/D clock or trigger signal** – You can wire external clock/trigger signals in one of the following ways:
 - Using the BNC connectors labelled AD Clock for A/D clock signals and AD Trig for A/D trigger signals.
 - Using the appropriate pins on the CT/Enc In, Analog Out, Clk/Trig connector. You can access the pins by building your own cable/panel. Refer to [page 45](#) for connector pin assignments.
- **External DAC clock or trigger signal** – If your version of the DT9832 module supports analog output operations, you can wire external clock/trigger signals in one of the following ways:
 - Using the BNC connectors labelled DAC Clock for D/A clock signals and DAC Trig for D/A trigger signals.
 - Using the appropriate pins on the CT/Enc In, Analog Out, Clk/Trig connector. You can access the pins by building your own cable/panel. Refer to [page 45](#) for connector pin assignments.

The following sections describe how to wire signals using the BNC or D-sub connectors.

Wiring Signals to the BNC Connectors

To wire signals using the BNC connectors, connect the appropriate BNC connector to the appropriate input/output using a BNC cable.

The number of BNC connectors available on the box varies, depending on the version of the box that you are using. For example, the DT9832-04-2-BNC version, shown in [Figure 5 on page 41](#), contains 10 BNC connectors (4 BNC connectors for single-ended

analog inputs, two BNC connectors for analog outputs, and four BNC connectors for external clocks and triggers).

As another example, the DT9832A-02-2-BNC version, shown in [Figure 6](#), contains 8 BNC connectors (two BNC connectors for analog inputs, two BNC connectors for analog outputs, and four BNC connectors for external clocks and triggers).

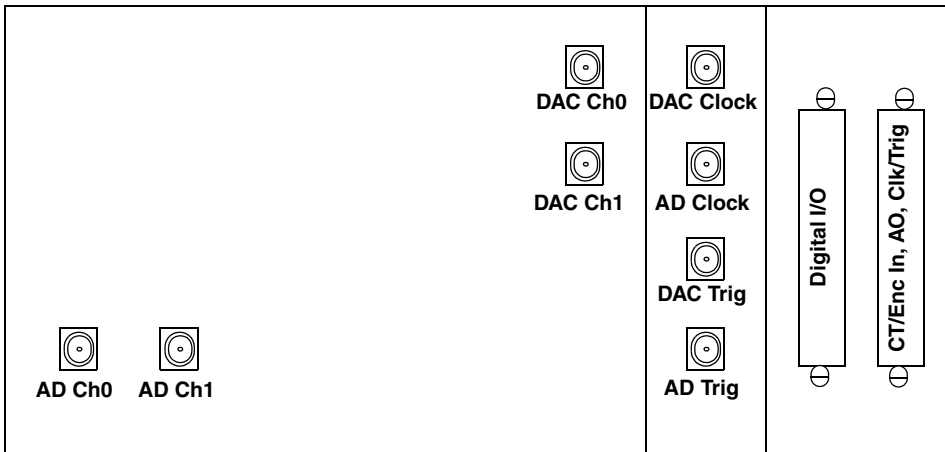

Figure 6: DT9832A-02-2-BNC Version of the BNC Connection Box

Wiring Signals to the D-Sub Connectors

If you want to connect digital I/O or counter/timer signals to the BNC connection box, you can use the 37-pin, D-sub connectors. These connectors are described in the following sections.

Note: D-sub connectors are not available on the BNC connection box for analog input.

Digital In/Out Connector

The Digital In/Out connector allows you to access the digital I/O signals. [Table 2](#) lists the pin assignments for the Digital In/Out connector on the BNC connection box.

Table 2: Digital In/Out Connector Pin Assignments

Pin	Signal Description	Pin	Signal Description
1	Digital Input 0	20	Digital Output 0
2	Digital Input 1	21	Digital Output 1
3	Digital Input 2	22	Digital Output 2
4	Digital Input 3	23	Digital Output 3
5	Digital Input 4	24	Digital Output 4
6	Digital Input 5	25	Digital Output 5
7	Digital Input 6	26	Digital Output 6
8	Digital Input 7	27	Digital Output 7
9	Digital Input 8	28	Digital Output 8
10	Digital Input 9	29	Digital Output 9
11	Digital Input 10	30	Digital Output 10
12	Digital Input 11	31	Digital Output 11
13	Digital Input 12	32	Digital Output 12
14	Digital Input 13	33	Digital Output 13
15	Digital Input 14	34	Digital Output 14
16	Digital Input 15	35	Digital Output 15
17	Digital Ground	36	Reserved
18	Digital Ground	37	Digital Ground
19	No Connect		

CT/Enc In, Analog Out, Clk/Trig Connector

The CT/Enc In, Analog Out, Clk/Trig connector lets you access the counter/timer, quadrature decoder, analog output, external clock, and external trigger signals. [Table 3](#) lists the pin assignments for this connector on the BNC connection box.

Table 3: CT/Enc In, Analog Out, Clk/Trig Connector

Pin	Signal Description	Pin	Signal Description
1	Analog Output 0	20	Analog Output 0 Return
2	Analog Output 1	21	Analog Output 1 Return
3	Reserved	22	Reserved
4	Reserved	23	Reserved
5	Digital Ground	24	Digital Ground
6	External DAC Clock	25	External DAC Trigger
7	External ADC Clock	26	External ADC Trigger
8	Counter 0 Clock	27	Digital Ground
9	Counter 0 Out	28	Counter 0 Gate
10	Counter 1 Clock	29	Digital Ground
11	Counter 1 Out	30	Counter 1 Gate
12	Quad Dec 0 A	31	Digital Ground
13	Quad 0 Index	32	Quad Dec 0 B
14	Quad Dec 1 A	33	Digital Ground
15	Quad 1 Index	34	Quad Dec 1 B
16	Quad Dec 2 A	35	Digital Ground

Table 3: CT/Enc In, Analog Out, Clk/Trig Connector (cont.)

Pin	Signal Description	Pin	Signal Description
17	Quad 2 Index	36	Quad Dec 2 B
18	Digital Ground	37	Digital Ground
19	No Connect		

Connecting Analog Input Signals

The BNC connection box supports voltage inputs. You can connect analog input signals to a BNC connection box in **single-ended** mode. In this mode the source of the input should be close to the module, and all the input signals are referred to the same common ground.

Figure 7 shows how to connect single-ended voltage inputs (channels 0 and 1, in this case) to the BNC connectors on the BNC connection box.

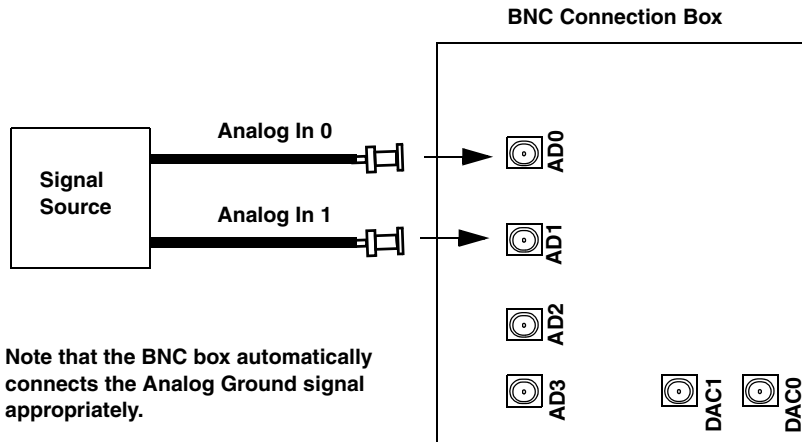

Figure 7: Connecting Single-Ended Inputs to the BNC Connection Box

Connecting Analog Output Signals

Figure 8 shows how to connect an analog output voltage signal (channel 0, in this case) to the BNC connectors on the BNC connection box.

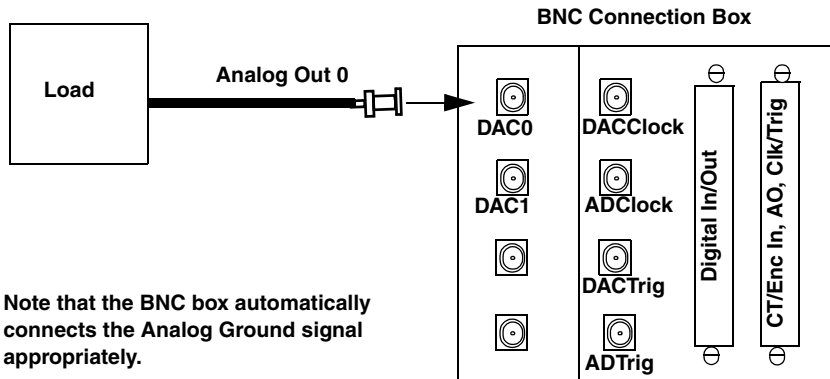

Figure 8: Connecting Analog Outputs to the BNC Connector Box

Connecting Digital I/O Signals

Figure 9 shows how to connect digital input signals (lines 0 and 1, in this case) to the Digital In/Out pins.

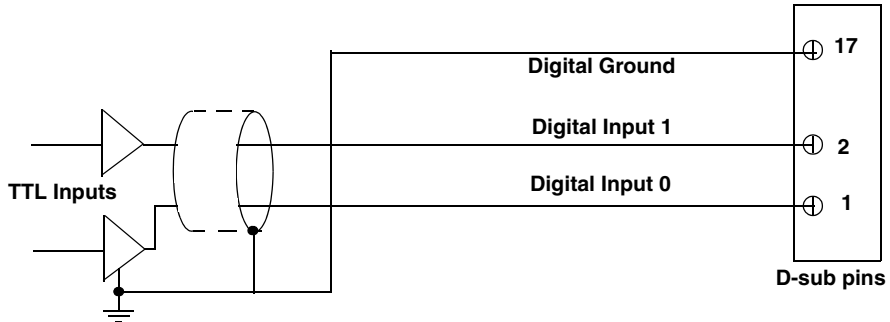

Figure 9: Connecting Digital Inputs to the D-sub Pins

Figure 10 shows how to connect a digital output (line 0, in this case) to the Digital In/Out pins.

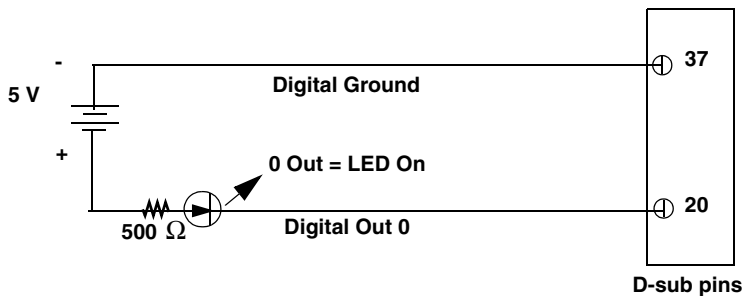

Figure 10: Connecting Digital Outputs to the D-sub Pins

Connecting Counter/Timer Signals

The BNC connection box provides two counter/timer channels that you can use for the following operations:

- Event counting
- Up/down counting
- Frequency measurement
- Pulse width/period measurement
- Edge-to-edge measurement
- Continuous edge-to-edge measurement
- Pulse output (continuous, one-shot, and repetitive one-shot)

This section describes how to connect counter/timer signals. Refer to [Chapter 5](#) for more information about using the counter/timers.

Event Counting

[Figure 11](#) shows how to connect counter/timer signals to the CT/Enc In, Analog Output, Clk/Trig D-sub pins to perform an event counting operation on counter/timer 0 using an external gate.

The counter counts the number of rising edges that occur on the Counter 0 Clock input when the Counter 0 Gate signal is in the active state (as specified by software). Refer to [Chapter 5](#) for more information.

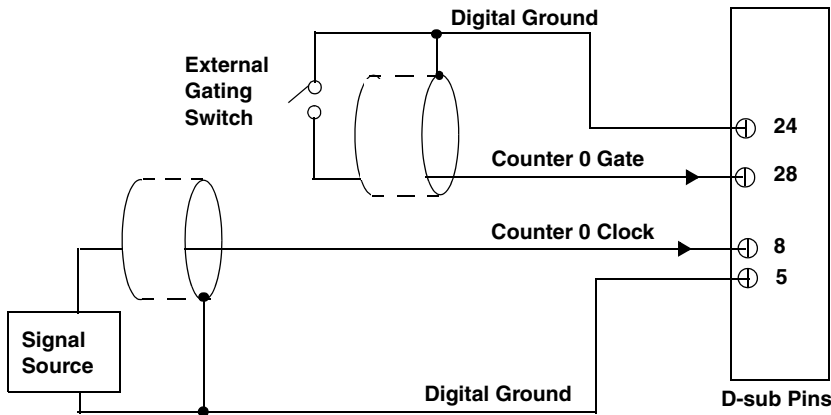

3

Figure 11: Connecting Counter/Timer Signals to the D-sub Pins for an Event Counting Operation Using an External Gate

Figure 12 shows how to connect counter/timer signals to the CT/Enc In, Analog Output, Clk/Trig D-sub pins to perform an event counting operation on counter/timer 0 without using a gate. The counter counts the number of rising edges that occur on the Counter 0 Clock input.

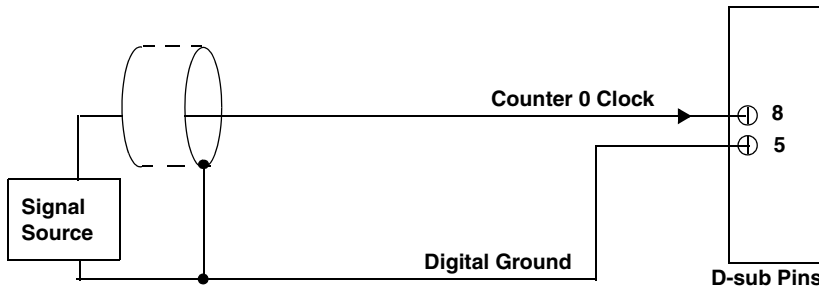

Figure 12: Connecting Counter/Timer Signals to the D-sub Pins for an Event Counting Operation Without Using a Gate

Up/Down Counting

Figure 13 shows how to connect counter/timer signals to the CT/Enc In, Analog Output, Clk/Trig D-sub pins to perform an up/down counting operation on counter/timer 0. The counter keeps track of the number of rising edges that occur on the Counter 0 Clock input. The counter increments when the Counter 0 Gate signal is high and decrements when the Counter 0 Gate signal is low.

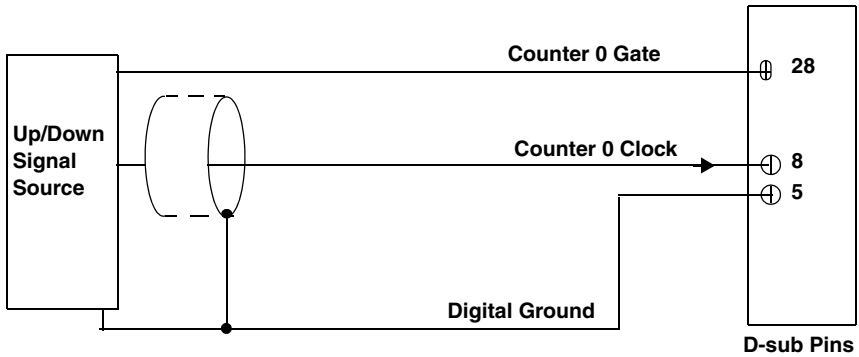

Figure 13: Connecting Counter/Timer Signals to the D-sub Pins for an Up/Down Counting Operation

Frequency Measurement

One way to measure frequency is to connect a pulse of a known duration (such as a one-shot output of counter/timer 1) to the Counter 0 Gate input.

Figure 14 shows how to connect counter/timer signals to the CT/Enc In, Analog Output, Clk/Trig D-sub pins. In this case, the frequency of the Counter 0 clock input is the number of counts divided by the period of the Counter 0 Gate input signal.

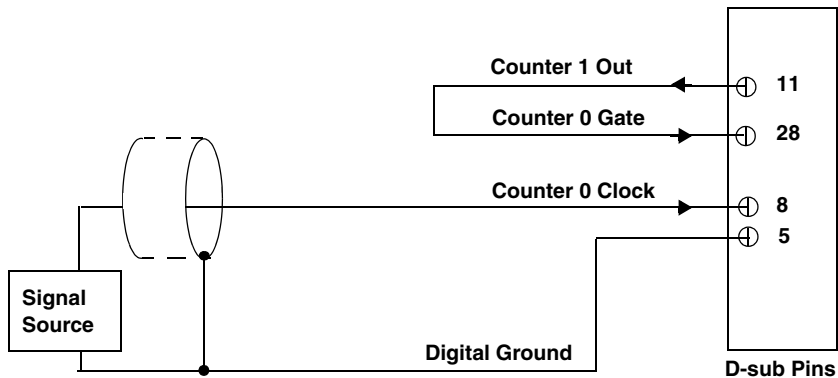

Figure 14: Connecting Counter/Timer Signals to the D-sub Pins for a Frequency Measurement Operation Using an External Pulse

Period/Pulse Width Measurement

Figure 15 shows how to connect counter/timer signals to the CT/Enc In, Analog Output, Clk/Trig D-sub pins to perform a period/pulse width measurement operation on counter/timer 0. You specify the active pulse (high or low) in software. The pulse width is the percentage of the total pulse period that is active. Refer to [Chapter 5](#) for more information about pulse periods and pulse widths.

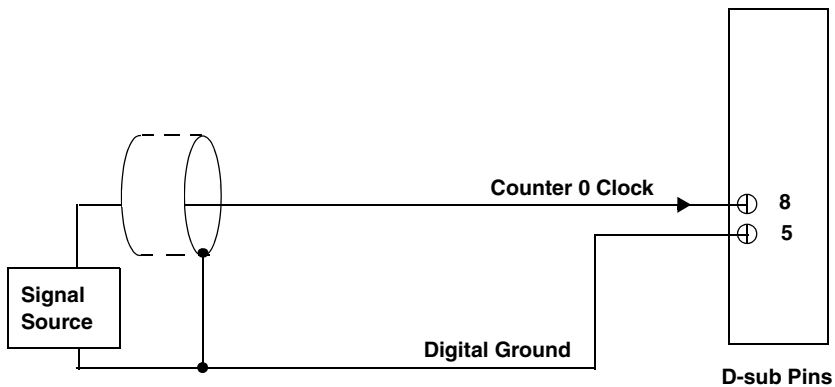

Figure 15: Connecting Counter/Timer Signals to the D-sub Pins for a Period/Pulse Width Measurement Operation

Edge-to-Edge Measurement

[Figure 16](#) shows how to connect counter/timer signals to the CT/Enc In, Analog Output, Clk/Trig D-sub pins to perform an edge-to-edge measurement operation using two signal sources. The counter measures the number of counts between the start edge (in this case, a rising edge on the Counter 0 Clock signal) and the stop edge (in this case, a falling edge on the Counter 0 Gate signal).

You specify the start edge and the stop edge in software. Refer to [Chapter 5](#) for more information on edge-to-edge measurement mode.

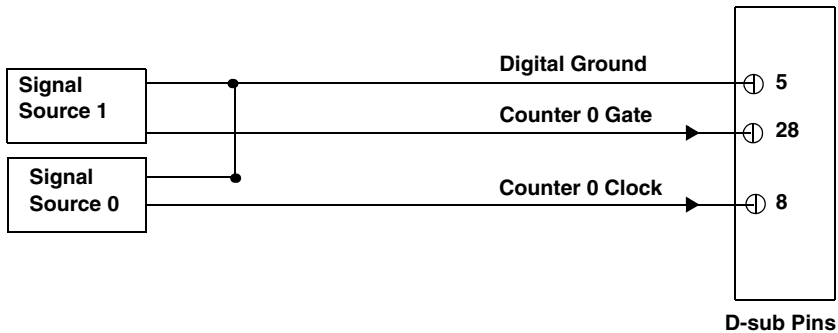

Figure 16: Connecting Counter/Timer Signals to the D-sub Pins for an Edge-to-Edge Measurement Operation

Continuous Edge-to-Edge Measurement

Figure 17 shows how to connect counter/timer signals to the CT/Enc In, Analog Output, Clk/Trig D-sub pins to perform a continuous edge-to-edge measurement operation. The counter measures the number of counts between two consecutive start edges (in this case, a rising edge on the Counter 0 Clock signal).

You specify the start edge in software. Refer to [Chapter 5](#) for more information on continuous edge-to-edge measurement operations.

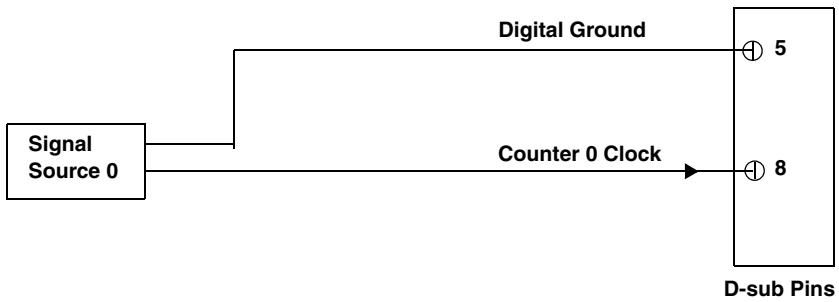

Figure 17: Connecting Counter/Timer Signals to the D-sub Pins for a Continuous Edge-to-Edge Measurement Operation

Pulse Output

Figure 18 shows how to connect counter/timer signals to the CT/Enc In, Analog Output, Clk/Trig D-sub pins to perform a pulse output operation on counter/timer 0; in this example, an external gate is used.

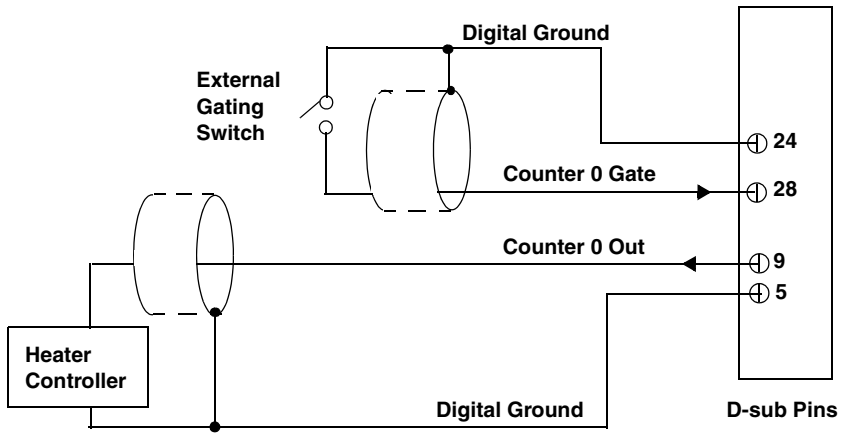

Figure 18: Connecting Counter/Timer Signals to the D-sub Pins for a Pulse Output Operation Using an External Gate

Connecting Quadrature Decoder Signals

The BNC connection box provides three quadrature decoder channels that allow simultaneous decoding of three quadrature encoded inputs.

Each quadrature decoder supports "A," "B," and "Index" inputs and is used to interface with a quadrature encoder sensor. The A and B input relationships are used to increment or decrement the positional count; the Index input can be used to zero-out the positional count. Refer to [Chapter 5](#) for more information about using the quadrature decoders.

[Figure 19](#) shows how to connect signals from a quadrature encoder to quadrature decoder 0 using the CT/Enc In, Analog Output, Clk/Trig D-sub pins.

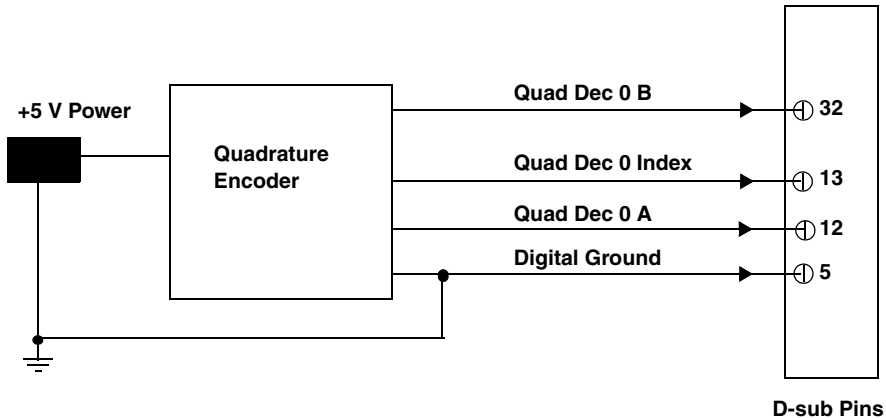
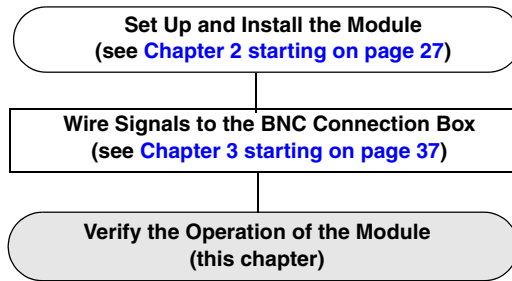

Figure 19: Connecting Quadrature Decoder Signals to the D-sub Pins



Verifying the Operation of a Module

Installing the Quick DataAcq Application	61
Running the Quick DataAcq Application.....	61
Testing Single-Value Analog Input	62
Testing Single-Value Analog Output.....	63
Testing Continuous Analog Input.....	64
Testing Single-Value Digital Input.....	65
Testing Single-Value Digital Output	66
Testing Frequency Measurement.....	67
Testing Pulse Output	68



You can verify the operation of a DT9832 Series module using the Quick DataAcq application. Quick DataAcq lets you do the following:

- Acquire data from a single analog input channel or digital input port
- Acquire data continuously from one or more analog input channels using an oscilloscope, strip chart, or Fast Fourier Transform (FFT) view
- Measure the frequency of events
- Output data from a single analog output channel or digital output port
- Output pulses either continuously or as a one-shot
- Save the input data to disk

Installing the Quick DataAcq Application

The Quick DataAcq application is installed automatically when you install the driver software.

Running the Quick DataAcq Application

To run the Quick DataAcq application, do the following:

1. If you have not already done so, power up your computer and any attached peripherals.
2. Click **Start** from the Task Bar.
3. Browse to **Programs | Data Translation, Inc | DT-Open Layers for Win32 | QuickDataAcq**.

The main menu appears.

Note: The Quick DataAcq application allows you to verify basic operations on the board; however, it may not support all of the board's features.

For information on each of the features provided, use the online help for the Quick DataAcq application by pressing F1 from any view or selecting the **Help** menu. If the system has trouble finding the help file, navigate to C:\Program Files\Data Translation\Win32\dtdataacq.hlp, where C: is the letter of your hard disk drive.

Testing Single-Value Analog Input

To verify that the module can read a single analog input value, do the following:

1. Connect a voltage source, such as a function generator, to analog input channel 0 on the DT9832 Series module. Refer to [page 47](#) for an example of how to connect an analog input.
2. In the Quick DataAcq application, choose **Single Analog Input** from the **Acquisition** menu.
3. Select the appropriate DT9832 Series module from the **Board** list box.
4. In the **Channel** list box, select analog input channel 0.
5. In the **Range** list box, select the range for the channel. The default is ± 10 V.
6. Select **Single Ended**.
7. Click **Get** to acquire a single value from analog input channel 0. *The application displays the value on the screen in both text and graphical form.*

Testing Single-Value Analog Output

Note: DT9832-04-0-BNC, DT9832-04-0-OEM, DT9832A-02-0-BNC, and DT9832A-02-0-OEM modules do not have analog outputs.

To verify that the module can output a single analog output value, do the following:

1. Connect an oscilloscope or voltmeter to analog output channel 0 on the module. Refer to [page 48](#) for an example of how to connect analog output signals.
2. In the Quick DataAcq application, choose **Single Analog Output** from the **Control** menu.
3. Select the appropriate DT9832 Series module from the **Board** list box.
4. In the **Channel** list box, select analog output channel 0.
5. In the **Range** list box, select the output range of DAC0. The default is ± 10 V.
6. Enter an output value, or use the slider to select a value, to output from DAC0.
7. Click **Send** to output a single value from analog output channel 0.
The application displays the output value both on the slider and in the text box.

Testing Continuous Analog Input

To verify that the module can perform a continuous analog input operation, do the following:

1. Connect known voltage sources, such as the outputs of a function generator, to analog input channels 0 and 1 on the DT9832 Series module.
2. In the Quick DataAcq application, choose **Scope** from the **Acquisition** menu.
3. Select the DT9832 Series module from the **Board** list box.
4. In the **Sec/Div** list box, select the number of seconds per division (.1 to .00001) for the display.
5. In the **Channel** list box, select analog input channel 1, and then click **Add** to add the channel to the channel list. Note that, by default, channel 0 is included in the channel list.
6. Click **Config** from the Toolbar.
7. In the **Config** dialog, select **ChannelType**, and then select **Single Ended**.
8. In the **Config** dialog, select **Range**, and then select **Bipolar**.
9. Click **OK** to close the dialog box.
10. In the **Trigger** box, select **Auto** to acquire data continuously from the specified channels or **Manual** to acquire a burst of data from the specified channels.
11. Click **Start** from the Toolbar to start the continuous analog input operation.
The application displays the values acquired from each channel in a unique color on the oscilloscope view.
12. Click **Stop** from the Toolbar to stop the operation.

Testing Single-Value Digital Input

To verify that the module can read a single digital input value, do the following:

1. Connect a digital input to digital input line 0 on the DT9832 Series module. Refer to [page 49](#) for information about how to connect a digital input.
2. In the Quick DataAcq application, choose **Digital Input** from the **Acquisition** menu.
3. Select the appropriate DT9832 Series module from the **Board** list box.
4. Click **Get**.
The application displays the entire 16-bit digital input value (0 to FFFF) in both the Data box and the Digital Input box.

In addition, application shows the state of the lower eight digital input lines (lines 0 to 7) in the graphical display. If an indicator light is lit (red), the line is high; if an indicator light is not lit (black), the line is low.

Note: Although the DT9832 Series modules contain 16 digital input lines, the Quick DataAcq application shows indicator lights for the lower eight digital input lines only. The 16-bit value is the correct value for all 16 lines.

Testing Single-Value Digital Output

Note: Although the DT9832 Series modules contain 16 digital output lines, the Quick DataAcq application allows you to perform a digital output operation on the lower eight digital output lines (lines 0 to 7) only.

To verify that the module can output a single digital output value, do the following:

1. Connect a digital output to digital output line 0 on the DT9832 Series module. Refer to [page 49](#) for information about how to connect a digital output.
2. In the Quick DataAcq application, choose **Digital Output** from the **Control** menu.
3. Select the appropriate DT9832 Series module from the **Board** list box.
4. Click the appropriate indicator lights to select the types of signals to write from the digital output lines. If you select a light, the module outputs a high-level signal; if you do not select a light, the module outputs a low-level signal. You can also enter an output value for the lower eight digital output lines (0 to FF) in the **Hex** text box.
5. Click **Send**.
The values of the lower eight digital output lines are output appropriately.

Testing Frequency Measurement

To verify that the module can perform a frequency measurement operation, do the following:

1. Wire an external clock source to counter/timer 0 on the DT9832 Series module. Refer to [page 53](#) for an example of how to connect an external clock.

Note: The Quick DataAcq application works only with counter/timer 0.

2. In the Quick DataAcq application, choose **Measure Frequency** from the **Acquisition** menu.
3. Select the appropriate DT9832 Series module from the **Board** list box.
4. In the **Count Duration** text box, enter the number of seconds during which events will be counted.
5. Click **Start** to start the frequency measurement operation.
The operation automatically stops after the number of seconds you specified has elapsed, and the frequency is displayed on the screen.
6. Click **Stop** to stop the frequency measurement operation.

Testing Pulse Output

To verify that the module can perform a pulse output operation, perform the following steps:

1. Connect a scope to counter/timer 0 on the DT9832 Series module. Refer to [page 56](#) for an example of how to connect a scope (a pulse output) to counter/timer 0.

Note: The Quick DataAcq application works only with counter/timer 0.

2. In the Quick DataAcq application, choose **Pulse Generator** from the **Control** menu.
3. Select the appropriate DT9832 Series module from the **Board** list box.
4. Select either **Continuous** to output a continuous pulse stream or **One Shot** to output one pulse.
5. Select either **Low-to-high** to output a rising-edge pulse (the high portion of the total pulse output period is the active portion of the signal) or **High-to-low** to output a falling-edge pulse (the low portion of the total pulse output period is the active portion of the signal).
6. Under **Pulse Width**, enter a percentage or use the slider to select a percentage for the pulse width. The percentage determines the duty cycle of the pulse.
7. Click **Start** to generate the pulse(s).
The application displays the results both in text and graphical form.
8. Click **Stop** to stop a continuous pulse output operation. One-shot pulse output operations stop automatically.

Part 2:
Using Your Module



Principles of Operation

Analog Input Features	73
Analog Output Features	84
Digital I/O Features	92
Counter/Timer Features	95
Quadrature Decoder Features	109

Figure 20 shows a block diagram of the DT9832 Series modules.

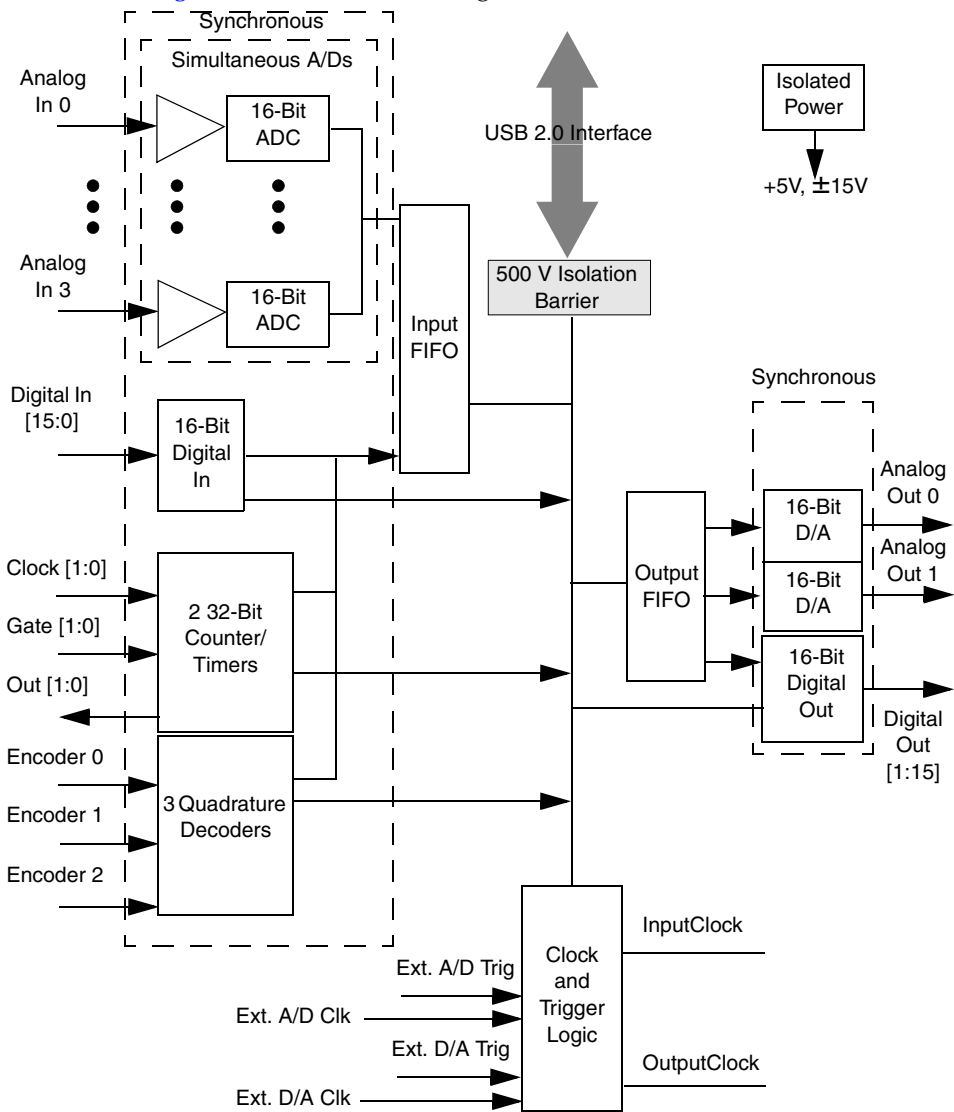

Figure 20: Block Diagram of the DT9832 Series Modules

Analog Input Features

This section describes the following features of analog input (A/D) operations on the DT9832 Series module:

- Input resolution, described below
- Analog input channels, described below
- Input ranges, described on [page 78](#)
- Input sample clock sources, described on [page 78](#)
- Analog input conversion modes, described on [page 79](#)
- Input triggers, described on [page 81](#)
- Data format and transfer, described on [page 82](#)
- Error conditions, described on [page 83](#)

Input Resolution

Input resolution is fixed at 16 bits; you cannot specify the resolution in software.

5

Analog Input Channels

The DT9832 supports four analog inputs. The DT9832A supports two analog inputs. You can connect the analog input channels in single-ended mode. In this mode the source of the input should be close to the module, and all the input signals are referred to the same common ground. The BNC connection box is shipped in a single-ended channel configuration.

Note: To maintain simultaneous operation, all analog input connections must have the same lead lengths. Do not use the STP37 screw terminal panel with the analog input subsystem.

The DT9832 Series modules can acquire data from a single analog input channel or from a group of analog input channels. Analog input channels are numbered 0 to 3 (DT9832) or 0 and 1 (DT9832A).

The following subsections describe how to specify the channels.

Specifying a Single Analog Input Channel

The simplest way to acquire data from a single analog input channel is to specify the channel for a single-value analog input operation using software; refer to [page 79](#) for more information about single-value operations.

You can also specify a single channel using the analog input channel list, described in the next section.

Specifying One or More Analog Input Channels

You can read data from one or more analog input channels using an analog input channel list. Because these modules feature simultaneous sampling, the order of the channels in the channel list does not matter. You cannot specify the same channel more than once in the list.

Using software, specify the channels that you want to sample. You can enter up to 15 entries in the channel list (13 for the DT9832A module), including digital input, two 32-bit counter/timers, and three 32-bit quadrature decoders. Channels 0 to 3 on the DT9832 (0 and 1 on the DT9832A) are reserved for analog input. Refer to [page 79](#) for more information about the supported conversion modes.

Specifying the Digital Input Port in the Analog Input Channel List

The DT9832 Series modules allow you to read the digital input port (all 16 digital input lines) using the analog input channel list. This feature is particularly useful when you want to correlate the timing of analog and digital events.

To read the digital input port, specify channel 2 (DT9832A) or channel 4 (DT9832) in the analog input channel list. You can enter channel 2 or 4 anywhere in the list.

The digital input port is treated like any other channel in the analog input channel list; therefore, all the clocking, triggering, and conversion modes supported for analog input channels are supported for the digital input port, if you specify them this way.

Specifying Counter/Timers in the Analog Input Channel List

The DT9832 Series modules allow you to read the value of the 32-bit counter/timer channels using the analog input channel list. This feature is particularly useful when you want to correlate the timing of analog and counter/timer events.

To read a counter/timer channel, specify the appropriate channel numbers in the analog input channel list (refer to [Table 4 on page 76](#)). You can enter a channel number anywhere in the list.

You need two channel list entries to read one 32-bit counter value. The first entry stores the lower 16-bit word, and the second entry stores the upper 16-bit word. You must specify both channel list entries, in sequential order, to include a counter/timer channel.

[Table 4](#) lists the channel number(s) to use for each counter/timer.

Table 4: Using Counter/Timers in Analog Input Channel List

Counter/Timer Channel	Description	Channel to Specify in the Channel List for:	
		DT9832	DT9832A
C/T_0_LOW	Lower 16 bits (0 to 15) of C/T 0	Channel 5	Channel 3
C/T_0_HI	Upper 16 bits (16 to 31) of C/T 0	Channel 6	Channel 4
C/T_1_LOW	Lower 16 bits (0 to 15) of C/T 1	Channel 7	Channel 5
C/T_1_HI	Upper 16 bits (16 to 31) of C/T 1	Channel 8	Channel 6

The counter/timer channel is treated like any other channel in the analog input channel list; therefore, all the clocking, triggering, and conversion modes supported for analog input channels are supported for the counter/timers, if you specify them this way.

Specifying Quadrature Decoders in the Analog Input Channel List

The DT9832 Series modules allow you to read the value of the 32-bit quadrature decoder channels using the analog input channel list. This feature is particularly useful when you want to correlate the timing of analog and quadrature decoder values.

To read a quadrature decoder channel, specify the appropriate channel numbers in the analog input channel list (refer to [Table 5 on page 77](#)). You can enter a channel number anywhere in the list.

You need two channel list entries to read one 32-bit counter value. The first entry stores the lower 16-bit word, and the second entry stores the upper 16-bit word. You must specify both channel list entries to include a quadrature decoder channel.

Table 5 lists the channel number(s) to use for each quadrature decoder.

Table 5: Using Quadrature Decoders in Analog Input Channel List

Quadrature Decoder Channel	Description	Channel to Specify in the Channel List for:	
		DT9832	DT9832A
QUAD_0_LOW	Lower 16 bits of Q/D 0	Channel 9	Channel 7
QUAD_0_HI	Upper 16 bits of Q/D 0	Channel 10	Channel 8
QUAD_1_LOW	Lower 16 bits of Q/D 1	Channel 11	Channel 9
QUAD_1_HI	Upper 16 bits of Q/D 1	Channel 12	Channel 10
QUAD_2_LOW	Lower 16 bits of Q/D 2	Channel 13	Channel 11
QUAD_2_HI	Upper 16 bits of Q/D 2	Channel 14	Channel 12

Note: If you are using the DataAcq SDK, you access the quadrature decoders through the C/T subsystem. C/T subsystem 2 corresponds to quadrature decoder 0, C/T subsystem 3 corresponds to quadrature decoder 1, and C/T subsystem 4 corresponds to quadrature decoder 2.

The quadrature decoder channel is treated like any other channel in the analog input channel list; therefore, all the clocking, triggering, and conversion modes supported for analog input channels are supported for the quadrature decoders, if you specify them this way.

Input Ranges

The DT9832 Series modules provide an input range of ± 10 V. Use software to specify the range as ± 10 V.

You do not need to (and cannot) set gain values for DT9832 Series modules. The gain is preset at 1.

Input Sample Clock Sources

DT9832 Series modules allow you to use one of the following clock sources to pace analog input operations:

- **Internal A/D clock** – Using software, specify the clock source as internal and the clock frequency at which to pace the operation. The minimum frequency supported is 0.01118 Samples/s; the maximum frequency supported is 1250 kSamples/s (for the DT9832 module) or 2000 kSamples/S (for the DT9832A module).

According to sampling theory (Nyquist Theorem), specify a frequency that is at least twice as fast as the input's highest frequency component. For example, to accurately sample a 20 kHz signal, specify a sampling frequency of at least 40 kHz. Doing so avoids an error condition called *aliasing*, in which high frequency input components erroneously appear as lower frequencies after sampling.

- **External A/D clock** – An external A/D clock is useful when you want to pace acquisitions at rates not available with the internal A/D clock or when you want to pace at uneven intervals.

Connect an external A/D clock to the AD Clock BNC connector on the DT9832 Series module. Conversions start on the falling edge of the external A/D clock input signal.

Using software, specify the clock source as external. The clock frequency is always equal to the frequency of the external A/D sample clock input signal that you connect to the module.

Note: If you specify the digital input port and/or counter/timer or quadrature decoder channels in the channel list, the input sample clock (internal or external) also paces the acquisition of the digital input port and/or counter/timer and quadrature decoder channels.

Analog Input Conversion Modes

DT9832 Series modules support the following conversion modes:

- Single-value mode, described below
- Continuous scan mode, described on [page 79](#)

Single-Value Mode

Single value operations are the simplest to use. Using software, you specify the analog input channel. The module acquires the data from the specified channel and returns the data immediately. For a single-value operation, you cannot specify a clock source, trigger source, scan mode, or buffer.

Single-value operations stop automatically when finished; you cannot stop a single-value operation.

Continuous Scan Mode

Continuous scan mode takes full advantage of the capabilities of the DT9832 Series modules. Use continuous scan mode if you want to accurately control the period between successive simultaneous conversions of all channels in a channel list. You specify the channel list, clock source, trigger source, scan mode, and buffer using software.

When it detects an initial trigger, the module simultaneously samples all of the input channels, including the digital inputs, counter/timers, and quadrature decoders, and converts the analog inputs. If the channel is included in the channel list, the sampled data is placed in the allocated buffer(s) and the operation continues until the allocated buffers are filled or until you stop the operation. Refer to [page 82](#) for more information about buffers.

The conversion rate is determined by the frequency of the input sample clock; refer to [page 78](#) for more information about the input sample clock. The sample rate, which is the rate at which a single entry in the channel list is sampled, is the same as the conversion rate due to the simultaneous nature of the module.

To select continuous scan mode, use software to specify the data flow as Continuous and to specify the initial trigger (the trigger source that starts the operation). You can select a software trigger, an external, positive digital (TTL) trigger, an external, negative digital (TTL) trigger, or a positive analog threshold trigger as the initial trigger. Refer to [page 81](#) for more information about the supported trigger sources.

[Figure 21](#) illustrates continuous scan mode using a channel list with three entries: channel 0, channel 1, and channel 2. In this example, analog input data is acquired simultaneously on all channels on each clock pulse of the input sample clock. Data is acquired continuously.

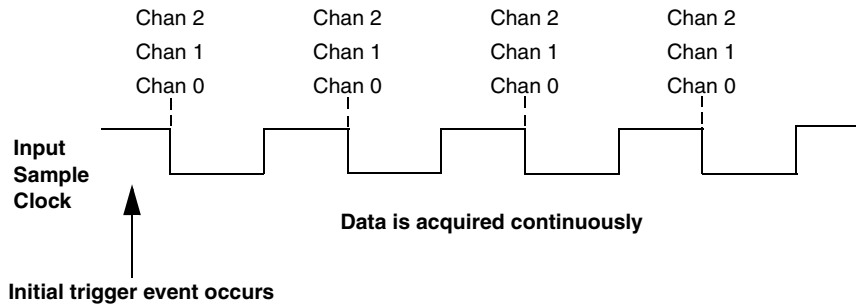

Figure 21: Continuous Scan Mode

Using software, you can stop a continuous scan by performing either an orderly stop or an abrupt stop. In an orderly stop, the module finishes acquiring the current buffer, stops all subsequent acquisition, and transfers the acquired data to host memory; any subsequent triggers are ignored.

In an abrupt stop, the module stops acquiring samples immediately; the current buffer is not completely filled, it is returned to the application only partially filled, and any subsequent triggers are ignored.

Input Triggers

A trigger is an event that occurs based on a specified set of conditions. Acquisition starts when the module detects the initial trigger event and stops when all the allocated buffers have been filled or when you stop the operation.

The DT9832 Series module supports the following trigger sources:

- **Software trigger** – A software trigger event occurs when you start the analog input operation (the computer issues a write to the module to begin conversions). Using software, specify the trigger source as a software trigger.
- **External digital (TTL) trigger** – An external digital (TTL) trigger event occurs when the DT9832 Series module detects either a rising-edge (positive) or falling-edge (negative) transition on the signal connected to the AD Trig BNC connector on the module. Using software, specify the trigger source as an external, positive digital (TTL) trigger or an external, negative digital (TTL) trigger.
- **Analog threshold trigger** – An analog threshold trigger event occurs when the signal on the first channel in the analog input channel list rises above (low-to-high transition) a programmable threshold level. Using software, specify the trigger source as a positive threshold trigger.

You must use analog input channel 0 as the analog trigger. The analog trigger channel must be the first entry in the analog input channel list.

You specify the threshold level by setting the value of the D/A subsystem that controls the threshold value. For modules that do not have analog output channels, this is D/A subsystem 0. For modules that do have analog outputs, this is D/A subsystem 1. Specify a value between 0 and 255, where 0 equals 0 V and 255 equals +10 V.

Data Format and Transfer

DT9832 Series modules use offset binary data encoding, where 0000 represents negative full-scale, and FFFFh represents positive full-scale. Use software to specify the data encoding as binary. The ADC outputs FFFFh for above-range signals, and 0000 for below-range signals.

Before you begin acquiring data, you must allocate buffers to hold the data. An event is raised whenever a buffer is filled. This allows you to move and/or process the data as needed.

Note: We recommend that you allocate a minimum of two buffers that can contain even multiples of 256 samples.

Data is written to multiple allocated input buffers continuously; when no more empty buffers are available, the operation stops. The data is gap-free.

Error Conditions

The DT9832 Series module reports any overrun errors by generating an overrun event. This event indicates that data buffers are not being sent from the host to the module fast enough, and so the A/D converter ran out of buffers. To avoid this error, try one or more of the following:

- Reduce the clock rate of the A/D
- Increase the size of the buffers
- Increase the number of buffers
- Close any other applications that are running
- Run the program on a faster computer

If one of these error conditions occurs, the module stops acquiring and transferring data to the host computer.

Analog Output Features

This section describes the following features of analog output operations:

- Output resolution, described below
- Analog output channels, described below
- Output ranges and gains, described on [page 86](#)
- Output triggers, described on [page 86](#)
- Output clocks, described on [page 87](#)
- Data format and transfer, described on [page 90](#)
- Error conditions, described on [page 91](#)

Output Resolution

Input resolution is fixed at 16 bits; you cannot specify the resolution in software.

Analog Output Channels

DT9832-04-2 and DT9832A-02-2 modules support two DC-level analog output channels (DAC0 and DAC1). Refer to [Chapter 3](#) starting on [page 37](#) for information about how to wire analog output signals to the module.

Note: An extra analog output (D/A) subsystem is provided on all DT9832 Series modules for controlling the analog threshold trigger. The threshold trigger DAC is the highest-numbered D/A subsystem supported by your module. Refer to [page 81](#) for more information on analog threshold triggering.

The DACs are deglitched to prevent noise from interfering with the output signal. They power up to a value of $0\text{ V} \pm 10\text{ mV}$. Unplugging the module resets the DACs to 0 V .

The DT9832 Series modules can output data to a single DAC or sequentially to one or more DACs and/or the digital output port. The following subsections describe how to specify the DACs/port.

Specifying a Single Analog Output Channel

The simplest way to output data to a single DAC is to specify the channel for a single-value analog output operation using software; refer to [page 87](#) for more information about single-value operations.

You can also specify a single DAC using the output channel list, described in the next section.

Specifying Multiple Analog Output Channels and/or the Digital Output Port

You can output data to one or more DACs and/or the digital output port using the output channel list. This feature is particularly useful when you want to correlate the timing of analog and digital output events.

Using software, specify the data flow mode as Continuous for the D/A subsystem (described on [page 87](#)) and specify the output channels you want to update, where 0 is DAC0, 1 is DAC1, and 2 is the digital output port. You can enter a maximum of 3 entries in the output channel list and the channels must be in order.

Note that you can skip a channel in the list, however, if you do not want to update it. For example, if you want to update only DAC1 and the digital output port, specify channels 1 and 2 in the output channel list. If you want to update all the DACs and the digital output ports, specify channels 0, 1, and 2 in the output channel list. The channels

are output in order from the first entry in the list to the last entry in the list.

Note: The digital output port is treated like any other channel in the output channel list; therefore, all the clocking, triggering, and conversion modes supported for analog output channels are supported for the digital output port, if you specify the digital output port in the output channel list.

Output Ranges and Gains

Each DAC on the DT9832 Series module can output bipolar analog output signals in the range of ± 10 V.

Output Triggers

A trigger is an event that occurs based on a specified set of conditions. The DT9832 Series modules support the following output trigger sources:

- **Software trigger** – A software trigger event occurs when you start the analog output operation. Using software, specify the trigger source as a software trigger.
- **External digital (TTL) trigger** – An external digital (TTL) trigger event occurs when the DT9832 Series module detects a rising-edge or falling-edge transition on the signal connected to the DAC Trig BNC connector on the module. Using software, specify the trigger source as either external, positive digital (TTL) trigger or external, negative digital (TTL) trigger.

Output Clocks

DT9832 Series modules allow you to use one of the following clock sources to pace analog output operations:

- **Internal DAC clock** – Using software, specify the clock source as internal and the clock frequency at which to pace the operation. The minimum frequency supported is 0.01118 Samples/s; the maximum frequency supported is 500 kSamples/s.
- **External DAC clock** – An external DAC clock is useful when you want to pace conversions at rates not available with the output sample clock or when you want to pace at uneven intervals.

Connect an external DAC clock to the DAC Clock BNC connector on the DT9832 Series module. Analog output operations start on the rising edge of the external DAC clock signal.

Using software, specify the clock source as external. The clock frequency is always equal to the frequency of the external DAC clock signal that you connect to the module.

Output Conversion Modes

DT9832 Series modules support the following conversion modes:

- **Single-value operations** are the simplest to use but offer the least flexibility and efficiency. Use software to specify the analog output channel that you want to update, and the value to output from that channel. For a single-value operation, you cannot specify a clock source, trigger source, or buffer. Single-value operations stop automatically when finished; you cannot stop a single-value operation.
- **Streaming analog output operations** take full advantage of the capabilities of the DT9832 Series modules. In this mode, you can specify an output channel list, clock source, trigger source, buffer, and buffer wrap mode. Two continuous analog output modes are supported: streaming and waveform generation mode. These modes are described in the following subsections.

Note that in waveform mode, each channel in the output channel list must write the same number of values, use the same output clock (refer to [page 87](#)), and use the same output trigger (refer to [page 86](#)).

Streaming Analog Output

Use streaming analog output mode if you want to accurately control the period between conversions of individual channels in the output channel list (refer to [page 85](#) for information on specifying the output channel list).

Use software to fill the output buffer with the values that you want to write to the DACs and to the digital output port, if applicable. For example, if your output channel list contains only DAC0 and the digital output port, specify the values in the output buffer as follows: the first output value for DAC0, the first output value for the digital output port, the second output value for DAC0, the second output value for the digital output port, and so on.

When it detects a trigger, the module starts writing the values from the output buffer to the channels specified in the output channel list. The operation repeats continuously until all the data is output from the buffers.

Make sure that the host computer transfers data to the output channel list fast enough so that the list does not empty completely; otherwise, an underrun error results.

To select streaming analog output mode, use software to specify the following parameters:

- Set the data flow as Continuous.
- Set WrapSingleBuffer to False to use multiple buffers.
- Set the trigger source to any of the supported trigger sources. Refer to [page 86](#) for more information about the supported trigger sources.

To stop a streaming analog output operation, you can stop sending data to the module, letting the module stop when it runs out of data, or you can perform either an orderly stop or an abrupt stop using software. In an orderly stop, the module finishes outputting the current buffer, and then stops; all subsequent triggers are ignored. In an abrupt stop, the module stops outputting samples immediately; all subsequent triggers are ignored.

Waveform Generation

Use waveform generation mode if you want to output a waveform repetitively.

Note: The waveform pattern size must be the same for all output channels, and the total number of samples must be a multiple of the total number of output channels.

Use software to fill the output buffer with the values that you want to write to the channels in the output channel list. For example, if your output channel list contains only DAC0 and the digital output port, specify the values in the output buffer as follows: the first output value for DAC0, the first output value for the digital output port, the second output value for DAC0, the second output value for the digital output port, and so on.

When it detects a trigger, the host computer transfers the entire waveform pattern to the module, and the module starts writing output values to the output channels, as determined by the output channel list. A single buffer is output repeatedly. Use software to allocate the memory and specify the waveform pattern.

To select waveform generation mode, use software to specify the following parameters:

- Set the data flow to Continuous.
- Set WrapSingleBuffer to True to use a single buffer. Refer to the following section for more information on this buffer wrap mode.
- Set the trigger source as any of the supported trigger sources (refer to [page 86](#)).

Data Format and Transfer

Data from the host computer must use offset binary data encoding for analog output signals, where 0000 represents -10 V, and FFFFh represents +10 V. Using software, specify the data encoding as binary.

Before you begin writing data to the output channels, you must allocate and fill buffers with the appropriate data. An event is returned whenever a buffer is transferred to the module. This allows you to reuse that buffer, and refill it with additional output data.

Note: If WrapSingleBuffer is False, we recommend that you allocate a minimum of two buffers that are even multiples of 256 samples. If WrapSingleBuffer is True, we recommend that you allocate a minimum of one buffer that is an even multiple of 256 samples.

In streaming mode, data is written from multiple output buffers continuously; when no more buffers of data are available, the operation stops. The data is gap-free. If the size of your buffers is less than 128K and you stop the analog output operation, the operation stops after the current buffer and the next buffer have been output.

If a single buffer is used (WrapSingleBuffer is True), data is written from a single output buffer continuously; when all the data in the buffer has been output, the module returns to the first location of the buffer and continues outputting the data. This process continues indefinitely until you stop it.

Note: If a single buffer is used and the allocated output buffer is equal to or less than the size of the FIFO on the module, the data is written once to the module. The module recycles the data, allowing you to output the same pattern continuously without any further CPU or USB bus activity.

Error Conditions

The DT9832 Series module reports any underrun errors by sending an underrun event to the application. This event indicates that data buffers are not being sent from the host to the module fast enough, and so the D/A converter ran out of data. To avoid this error, try one or more of the following:

- Reduce the clock rate of the D/A
- Increase the size of the buffers
- Increase the number of buffers
- Close any other applications that are running
- Run the program on a faster computer

Digital I/O Features

This section describes the following features of digital I/O operations:

- Digital I/O lines, described below
- Operation modes, described on [page 93](#)

Digital I/O Lines

DT9832 Series modules support one digital input port, consisting of 16 digital input lines (lines 0 to 15) and one digital output port, consisting of 16 digital output lines (lines 0 to 15). The resolution is fixed at 16 bits; you cannot change the resolution in software.

You can read all 16 digital input lines or write all 16 digital output lines with a single-value digital I/O operation.

In addition, you can specify the digital input port in an analog input channel list to perform a continuous digital input operation, or you can specify the digital output port in an output channel list to perform a continuous digital output operation.

A digital line is high if its value is 1; a digital line is low if its value is 0. On power up or reset, a low value (0) is output from each of the digital output lines.

The DT9832 Series modules allow you to program the first eight digital input lines to perform interrupt-on-change operations. Refer to the next section for more information.

Operation Modes

The DT9832 Series modules support the following digital I/O operation modes:

- **Single-value operations** are the simplest to use but offer the least flexibility and efficiency. You use software to specify the digital I/O port (the gain is ignored). Data is then read from or written to all the digital I/O lines. For a single-value operation, you cannot specify a clock or trigger source.

Single-value operations stop automatically when finished; you cannot stop a single-value operation.

- **Continuous digital I/O** takes full advantage of the capabilities of the DT9832 Series modules using the analog I/O clock source, scan mode, trigger source, buffer, and buffer wrap mode.
 - **Digital input** – For digital input operations, enter the digital input port (all 16 digital input lines) as channel 2 (for the DT9832A) or 4 (for the DT9832) in the analog input channel list; refer to [page 75](#) for more information. The analog input sample clock (internal or external) paces the reading of the digital input port (as well as the acquisition of the analog input, counter/timer, and quadrature decoder channels); refer to [page 78](#) for more information.
 - **Digital output** – For digital output operations, enter the digital output port (all 16 digital output lines) as channel 2 in the output channel list; refer to [page 85](#) for more information. The analog output clock (internal or external) paces the update of the digital output port (as well as the update of the analog output channels); refer to [page 87](#) for more information.

- **Interrupt-on-change operations** – You can use the Open Layers Control Panel applet or the DT-Open Layers for .NET Class Library to select any of the first eight digital input lines to perform interrupt-on-change operations; refer to [page 36](#) for more information.

Use software to set the data flow mode of the digital I/O subsystem to Continuous. When any one of the specified bits changes state, the module reads the entire 16-bit digital input value and generates an interrupt. The software returns the current value of the digital input port as well as the digital input lines that changed state.

Note: If you are using the DataAcq SDK to perform a continuous digital input operation, use the *lParam* parameter of the **oldaSetWndHandle** or **oldaSetNotificationProcedure** function to determine which digital input line changed state and the status of the digital input port when the interrupt occurred.

The low byte of the first word of *lParam* contains the state of the digital input subsystem, where bit 0 corresponds to digital input line 0 and bit 7 corresponds to digital input line 7.

The high byte of the first word of *lParam* contains the digital lines (bits) that changed state causing the interrupt to occur, where bit 8 corresponds to digital input line 0 and bit 15 corresponds to digital input line 7.

Counter/Timer Features

This section describes the following features of counter/timer (C/T) operations:

- C/T channels, described below
- C/T clock sources, described on [page 96](#)
- Gate types, described on [page 97](#)
- Pulse types and duty cycles, described on [page 98](#)
- C/T operation modes, described on [page 99](#)

C/T Channels

The DT9832 Series modules provide two 32-bit counter/timers (C/T subsystems 0 and 1) for general-purpose use.

Each general-purpose counter accepts a clock input signal and gate input signal and outputs a pulse (pulse output signal), as shown in [Figure 22](#).

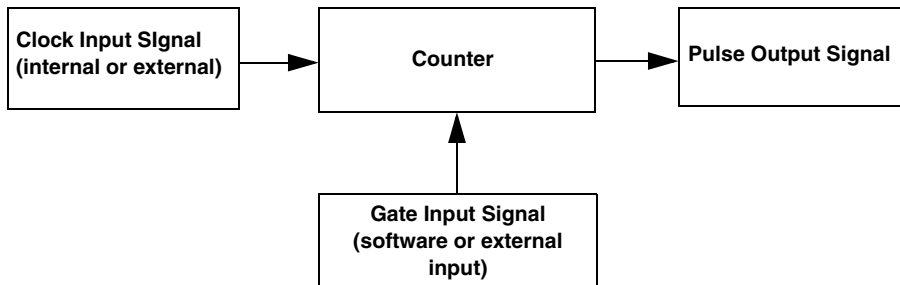

Figure 22: Counter/Timer Channel

To specify the counter/timer to use in software, specify the appropriate C/T subsystem.

Using software, you can also specify one or more of the counter/timers in the analog input channel list. You need two channel list entries to read a 32-bit counter value. The first entry stores the lower 16-bit word, and the second entry stores the upper 16-bit word. Refer to [page 75](#) for more information about using C/Ts in the channel list.

C/T Clock Sources

The following clock sources are available for the general-purpose counter/timers:

- **Internal C/T clock** – Through software, specify the clock source as internal, and specify the frequency at which to pace the operation (this is the frequency of the Counter *n* Out signal). This is typically used in rate generation mode.
- **External C/T clock** – An external C/T clock is useful when you want to pace counter/timer operations at rates not available with the internal C/T clock or if you want to pace at uneven intervals. The frequency of the external C/T clock can range up to 24 MHz.

Connect the external clock to the Counter *n* Clock input signal on the DT9832 Series module. Counter/timer operations start on the rising edge of the clock input signal.

Note: You typically use the external C/T clock (the clock connected to the Counter n Clock input signal) to measure frequency (event counting), or to measure the time interval between edges (measure mode). The external C/T clock is not generally used for rate generation.

If you specify a counter/timer in the analog input channel list, the A/D clock determines how often you want to read the counter value. Refer to [page 78](#) for more information about the A/D clock.

Gate Types

The edge or level of the Counter n Gate signal determines when a counter/timer operation is enabled. DT9832 Series modules provide the following gate types:

- **None** – A software command enables any counter/timer operation immediately after execution.
- **Logic-low level external gate input** – Enables a counter/timer operation when the Counter n Gate signal is low, and disables the counter/timer operation when the Counter n Gate signal is high. Note that this gate type is used for event counting and rate generation modes; refer to [page 99](#) for more information about these modes.
- **Logic-high level external gate input** – Enables a counter/timer operation when the Counter n Gate signal is high, and disables a counter/timer operation when the Counter n Gate signal is low. Note that this gate type is used for event counting and rate generation modes; refer to [page 99](#) for more information about these modes.

- **Falling-edge external gate input** – Enables a counter/timer operation when a high-to-low transition is detected on the Counter n Gate signal. In software, this is called a low-edge gate type. Note that this gate type is used for edge-to-edge measurement, one-shot, and repetitive one-shot mode; refer to [page 99](#) for more information about these modes.
- **Rising-edge external gate input** – Enables a counter/timer operation when a low-to-high transition is detected on the Counter n Gate signal. In software, this is called a high-edge gate type. Note that this gate type is used for edge-to-edge measurement, one-shot, and repetitive one-shot mode; refer to [page 99](#) for more information about these modes.

Specify the gate type in software.

Pulse Output Types and Duty Cycles

The DT9832 Series modules can output the following types of pulses from each counter/timer:

- **High-to-low transitions** – The low portion of the total pulse output period is the active portion of the counter/timer clock output signal.
- **Low-to-high transitions** – The high portion of the total pulse output period is the active portion of the counter/timer pulse output signal.

You specify the pulse output type in software.

The duty cycle (or pulse width) indicates the percentage of the total pulse output period that is active. For example, a duty cycle of 50 indicates that half of the total pulse output is low and half of the total pulse output is high. You specify the duty cycle in software.

[Figure 23](#) illustrates a low-to-high pulse with a duty cycle of approximately 30%.

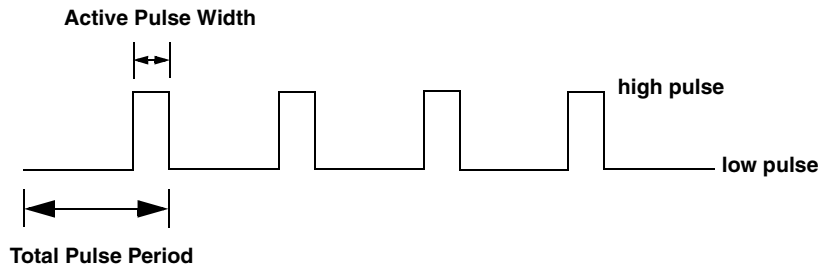

Figure 23: Example of a Low-to-High Pulse Output Type

Counter/Timer Operation Modes

DT9832 Series modules support the following counter/timer operation modes:

- Event counting
- Up/down counting
- Frequency measurement
- Edge-to-edge measurement
- Continuous edge-to-edge measurement
- Rate generation
- One-shot
- Repetitive one-shot

Note: The active polarity for each counter/timer operation mode is software-selectable.

The following subsections describe these modes in more detail.

Event Counting

Use event counting mode if you want to count the number of rising edges that occur on the Counter n Clock input when the Counter n Gate signal is active (low-level or high-level). Refer to [page 97](#) for information about specifying the active gate type.

You can count a maximum of 4,294,967,296 events before the counter rolls over to 0 and starts counting again.

Using software, specify the counter/timer mode as event counting (count), the C/T clock source as external, and the active gate type as low-level or high-level.

Make sure that the signals are wired appropriately. Refer to [Chapter 3](#) for an example of connecting an event counting application.

Up/Down Counting

Use up/down counting mode if you want to increment or decrement the number of rising edges that occur on the Counter n Clock input, depending on the level of the Counter n Gate signal.

If the Counter n Gate signal is high, the C/T increments; if the specified gate signal is low, the C/T decrements.

Using software, specify the counter/timer mode as up/down counting (up/down), and the C/T clock source as external. Note that you do not specify the gate type in software.

Make sure that the signals are wired appropriately. Refer to [Chapter 3](#) for an example of connecting an up/down counting application.

Note: Initialize the counter/timer so that the C/T never increments above FFFFFFFFh nor decrements below 0.

Frequency Measurement

Use frequency measurement mode if you want to measure the number of rising edges that occur on the Counter *n* Clock input over a specified duration.

Using software, specify the counter/timer mode as frequency measurement (count) or event counting (count), the clock source as external, and the time over which to measure the frequency.

You can use the Windows timer (which uses a resolution of 1 ms), or if you need more accuracy than the Windows timer provides, you can connect a pulse of a known duration (such as a one-shot output of another user counter) to the Counter *n* Gate input signal.

If you use a known pulse, use software to set up the counter/timers as follows:

1. Set up one of the counter/timers for one-shot mode, specifying the clock source as internal, the clock frequency, the gate type that enables the operation as rising edge or falling edge, and the polarity of the output pulse as high-to-low transition or low-to-high transition.
2. Set up the counter/timer that will measure the frequency for event counting mode, specifying the type of clock pulses to count and the gate type (this should match the pulse output type of the counter/timer set up for one-shot mode).
3. Start both counters (pulses are not counted until the active period of the one-shot pulse is generated).

4. Read the number of pulses counted. (Allow enough time to ensure that the active period of the one-shot occurred and that events have been counted.)
5. Determine the measurement period using the following equation:

$$\text{Measurement period} = \frac{1}{\text{Clock Frequency}} * \text{Active Pulse Width}$$

6. Determine the frequency of the clock input signal using the following equation:

$$\text{Frequency Measurement} = \frac{\text{Number of Events}}{\text{Measurement Period}}$$

Make sure that the signals are wired appropriately. One way to wire a frequency measurement operation is to use the same wiring as an event counting application, but not use an external gate signal. Refer to [Chapter 3](#) for an example of connecting a frequency measurement application.

Edge-to-Edge Measurement

Use edge-to-edge measurement mode if you want to measure the time interval between a specified start edge and a specified stop edge.

The start edge and the stop edge can occur on the rising edge of the Counter *n* Gate input, the falling edge of the Counter *n* Gate input, the rising edge of the Counter *n* Clock input, or the falling edge of the Counter *n* Clock input. When the start edge is detected, the counter/timer starts incrementing, and continues incrementing until the stop edge is detected. The C/T then stops incrementing until it is enabled to start another measurement.

You can use edge-to-edge measurement mode to measure the following:

- Pulse width of a signal pulse (the amount of time that a signal pulse is in a high or a low state, or the amount of time between a rising edge and a falling edge or between a falling edge and a rising edge). You can calculate the pulse width as follows:
 - $\text{Pulse width} = \text{Number of counts} / 48 \text{ MHz}$
- Period of a signal pulse (the time between two occurrences of the same edge - rising edge to rising edge or falling edge to falling edge). You can calculate the period as follows:
 - $\text{Period} = 1 / \text{Frequency}$
 - $\text{Period} = \text{Number of counts} / 48 \text{ MHz}$
- Frequency of a signal pulse (the number of periods per second). You can calculate the frequency as follows:
 - $\text{Frequency} = 48 \text{ MHz} / \text{Number of Counts}$

When the operation completes, you can read the value of the counter.

Using software, specify the counter/timer mode as edge-to-edge measurement mode (measure), the C/T clock source as internal, the start edge type, and the stop edge type.

Make sure that the signals are wired appropriately. Refer to [Chapter 3](#) for an example of connecting an edge-to-edge measurement application.

Continuous Edge-to-Edge Measurement

In continuous edge-to-edge measurement mode, the counter starts incrementing when it detects the specified start edge. When it detects the next start edge type, the value of the counter is stored and the next edge-to-edge measurement operation begins automatically.

Every time an edge-to-edge measurement operation completes, the previous measurement is overwritten with the new value. When you read the counter as part of the analog input data stream, the current value (from the last edge-to-edge measurement operation) is returned and the value of the counter is reset to 0. Refer to [page 102](#) for more information on edge-to-edge measurement mode.

Note: If you read the counter before the measurement is complete, 0 is returned.

For example, you might see results similar to the following if you read the value of the counter/timer as part of the analog input data stream:

Table 6: An Example of Performing a Continuous Edge-to-Edge Measurement Operation as Part of the Analog Input Channel List

Time	A/D Value	Counter/ Timer Value	Status of Continuous Edge-to-Edge Measurement Mode
10	5002	0	Operation started when the C/T subsystem was configured, but is not complete
20	5004	0	Operation not complete
30	5003	0	Operation not complete

Table 6: An Example of Performing a Continuous Edge-to-Edge Measurement Operation as Part of the Analog Input Channel List (cont.)

Time	A/D Value	Counter/ Timer Value	Status of Continuous Edge-to-Edge Measurement Mode
40	5002	12373	Operation complete
50	5000	0	Next operation started, but is not complete
60	5002	0	Operation not complete
70	5004	0	Operation not complete
80	5003	12403	Operation complete
90	5002	0	Next operation started, but is not complete

To select continuous edge-to-edge measurement mode, use software to specify the counter/timer mode as continuous measure, the C/T clock source as internal, and the start edge type.

5

Rate Generation

Use rate generation mode to generate a continuous pulse output signal from the Counter n Out line; this mode is sometimes referred to as continuous pulse output or pulse train output. You can use this pulse output signal as an external clock to pace other operations, such as analog input, analog output, or other counter/timer operations.

The pulse output operation is enabled whenever the Counter n Gate signal is at the specified level. While the pulse output operation is enabled, the counter outputs a pulse of the specified type and frequency continuously. As soon as the operation is disabled, rate generation stops.

The period of the output pulse is determined by the C/T clock source (either internal using a clock divider, or external). You can output pulses using a maximum frequency of 20 MHz (this is the frequency of the Counter n Out signal). Refer to [page 96](#) for more information about the C/T clock sources.

Using software, specify the counter/timer mode as rate generation (rate), the C/T clock source as either internal or external, the clock divider (for an internal clock), the polarity of the output pulses (high-to-low transition or low-to-high transition), the duty cycle of the output pulses, and the active gate type (low-level or high-level). Refer to [page 98](#) for more information about pulse output signals and to [page 97](#) for more information about gate types.

Make sure that the signals are wired appropriately. Refer to [Chapter 3](#) for an example of connecting a rate generation application.

One-Shot

Use one-shot mode to generate a single pulse output signal from the Counter n Out line when the specified edge is detected on the Counter n Gate signal. You can use this pulse output signal as an external digital (TTL) trigger to start other operations, such as analog input or analog output operations.

After the single pulse is output, the one-shot operation stops. All subsequent clock input signals and gate input signals are ignored.

The period of the output pulse is determined by the C/T clock source (either internal using a clock divider, or external). Note that in one-shot mode, the internal C/T clock is more useful than an external C/T clock; refer to [page 96](#) for more information about the C/T clock sources.

Using software, specify the counter/timer mode as one-shot, the clock source as internal (recommended), the clock divider, the polarity of the output pulse (high-to-low transition or low-to-high

transition), and the active gate type (rising edge or falling edge). Refer to [page 98](#) for more information about pulse output types and to [page 97](#) for more information about gate types.

Note: In the case of a one-shot operation, a duty cycle of 100% is set automatically.

Make sure that the signals are wired appropriately. Refer to [Chapter 3](#) for an example of connecting a one-shot application.

Repetitive One-Shot

Use repetitive one-shot mode to generate a pulse output signal from the Counter n Out line whenever the specified edge is detected on the Counter n Gate signal. You can use this mode to clean up a poor clock input signal by changing its pulse width, and then outputting it.

The module continues to output pulses until you stop the operation. Note that any Counter n Gate signals that occur while the pulse is being output are not detected by the module.

The period of the output pulse is determined by the C/T clock source (either internal using a clock divider, or external). Note that in repetitive one-shot mode, the internal C/T clock is more useful than an external clock; refer to [page 96](#) for more information about the C/T clock sources.

Using software, specify the counter/timer mode as repetitive one-shot, the polarity of the output pulses (high-to-low transition or low-to-high transition), the C/T clock source as internal (recommended), and the active gate type (rising edge or falling edge). Refer to [page 98](#) for more information about pulse output types and to [page 97](#) for more information about gates.

Note: In the case of a one-shot operation, a duty cycle of 100% is set automatically.

Make sure that the signals are wired appropriately. Refer to [Chapter 3](#) for an example of connecting a repetitive one-shot application.

Quadrature Decoder Features

The DT9832 Series modules provide three 32-bit quadrature decoders that allow simultaneous decoding of three quadrature encoded inputs. Quadrature decoders may be used to provide relative or absolute position, or determine rotational speed by calculating the difference between samples.

To specify the quadrature decoder to use in software, specify the appropriate QUAD subsystem. For example, quadrature decoder 0 corresponds to QUAD subsystem element 0, and quadrature decoder 1 corresponds to QUAD subsystem element 1.

Note: If you are using the DataAcq SDK, you access the quadrature decoders through the C/T subsystem. C/T subsystem 2 corresponds to quadrature decoder 0, C/T subsystem 3 corresponds to quadrature decoder 1, and C/T subsystem 4 corresponds to quadrature decoder 2.

5

Using software, you can also specify one or more of the quadrature decoders in the analog input channel list. You need two channel list entries to read a 32-bit quadrature decoder value. The first entry stores the lower 16-bit word, and the second entry stores the upper 16-bit word. Refer to [page 76](#) for more information about using quadrature decoders in the channel list.

Each quadrature decoder supports "A," "B," and "Index" inputs and is used to interface with a quadrature encoder sensor. The A and B input relationships are used to increment or decrement the positional count; the Index input can be used to zero-out the positional count.

[Figure 24](#) shows an example of a quadrature decoder mode. In this case, the A input leads the B input, up counting with a 90 degree Index.

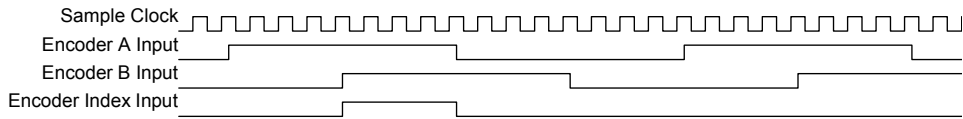

Figure 24: Example Quadrature Decoder Mode

Using software, you can specify the following parameters for a quadrature decoder operation:

- The pre-scale value that is used to filter the onboard clock. Using a pre-scale value can remove ringing edges and unwanted noise for more accurate data.
- The scaling mode (X1 or X4 mode) to match the quadrature encoder mode.
- The index mode, which either enables the Index signal or disables the Index signal.

Note: For quadrature decoder operations, set the clock source to external.

You can read the value of the quadrature decoder subsystem to determine relative or absolute position. To determine the rotation of a quadrature encoder, use the following formula:

$$\text{Rotation degrees} = \frac{\text{Count}}{4 * N} \times 360 \text{ degrees}$$

where N is the number of pulses generated by the quadrature encoder per rotation. For example, if every rotation of the quadrature encoder generated 10 pulses, and the value read from the quadrature decoder is 20, the rotation of the quadrature encoder is 180 degrees ($20/40 \times 360$ degrees).



Supported Device Driver Capabilities

Data Flow and Operation Options.....	115
Buffering	116
Triggered Scan Mode	117
Gain	119
Channels	118
Ranges	119
Resolution	120
Thermocouple and RTD Support.....	120
IEPE Support.....	121
Triggers	122
Clocks.....	123
Counter/Timers	124

The DT9832 Series Device Driver provides support for the analog input (A/D), analog output (D/A), digital input (DIN), digital output (DOUT), counter/timer (C/T), and quadrature decoder (QUAD) subsystems. For information on how to configure the device driver, refer to [page 36](#).

Table 7: DT9832 Series Subsystems

DT9832 Series	A/D	D/A	DIN	DOUT	C/T	QUAD
Total Subsystems on Module	1	1 or 2 ^a	1	1	2	3

- a. If your module does not support D/A, there is still one subsystem (element 0) for the analog threshold trigger. If your module does support D/A, subsystem element 0 contains the analog output channels, and element 1 is used for the analog threshold trigger.

The tables in this chapter summarize the features available for use with the DT-Open Layers for .NET Class Library and the DT9832 Series modules. The DT-Open Layers for .NET Class Library provides properties that return support information for specified subsystem capabilities.

The first row in each table lists the subsystem types. The first column in each table lists all possible subsystem capabilities. A description of each capability is followed by the property used to describe that capability in the DT-Open Layers for .NET Class Library.

Note: Blank fields represent unsupported options.

For more information, refer to the description of these properties in the DT-Open Layers for .NET Class Library online help or *DT-Open Layers for .NET Class Library User's Manual*.

Data Flow and Operation Options

Table 8: DT9832 Series Data Flow and Operation Options

DT9832 Series	A/D	D/A	DIN	DOUT	C/T	QUAD
Single-Value Operation Support SupportsSingleValue	Yes	Yes	Yes	Yes	Yes	Yes
Simultaneous Single-Value Output Operations SupportsSetSingleValues						
Continuous Operation Support SupportsContinuous	Yes	Yes	Yes ^a	Yes ^b	Yes ^c	Yes ^d
Continuous Operation until Trigger SupportsContinuousPreTrigger						
Continuous Operation before & after Trigger SupportsContinuousPrePostTrigger						
Waveform Operations Using FIFO Only SupportsWaveformModeOnly						
Simultaneous Start List Support SupportsSimultaneousStart	Yes	Yes				
Supports Programmable Synchronization Modes SupportsSynchronization						
Synchronization Modes SynchronizationMode						
Interrupt Support SupportsInterruptOnChange			Yes ^e			
Output FIFO Size FifoSize		128K				
Auto-Calibrate Support SupportsAutoCalibrate						

- a. The DIN subsystem supports continuous mode by allowing you to read the digital input port (all 16 digital input lines) using the analog input channel list.
- b. The DOUT subsystem supports continuous mode by allowing you to output data from the digital output port (all 16 digital output lines) using the output channel list.

- c. The C/T subsystem supports continuous mode by allowing you to read the value of one or more of the 2 general-purpose counter/timer channels using the analog input channel list.
- d. The QUAD subsystem supports continuous mode by allowing you to read the value of one or more of the 3 quadrature decoders using the analog input channel list.
- e. The first 8 digital input lines of the digital input port can generate an interrupt-on-change event. You enable the interrupts on a line-by-line basis during driver configuration; refer to [page 36](#) for more information on configuring the driver. If you are using the DataAcq SDK, refer to [page 93](#) for more information about determining which digital input lines changed state.

Buffering

Table 9: DT9832 Series Buffering Options

DT9832 Series	A/D	D/A	DIN	DOUT	C/T	QUAD
Buffer Support SupportsBuffering	Yes	Yes				
Single Buffer Wrap Mode Support SupportsWrapSingle		Yes				
Inprocess Buffer Flush Support SupportsInProcessFlush	Yes ^a					

- a. Data from the DT9832 Series module is transferred to the host in 4,096-byte (2,048-sample) segments. If the application moves data from the buffer before the module has transferred 2,048 samples to the host, the resulting buffer will contain 0 samples. Your application program must deal with these situations when flushing an inprocess buffer.

Triggered Scan Mode

Table 10: DT9832 Series Triggered Scan Mode Options

DT9832 Series	A/D	D/A	DIN	DOUT	C/T	QUAD
Triggered Scan Support SupportsTriggeredScan						
Maximum Number of CGL Scans per Trigger MaxMultiScanCount	1	0	0	0	0	0
Maximum Retrigger Frequency MaxRetriggerFreq	0	0	0	0	0	0
Minimum Retrigger Frequency MinRetriggerFreq	0	0	0	0	0	0

Data Encoding

Table 11: DT9832 Series Data Encoding Options

DT9832 Series	A/D	D/A	DIN	DOUT	C/T	QUAD
Binary Encoding Support SupportsBinaryEncoding	Yes	Yes	Yes	Yes	Yes	Yes
Twos Complement Support SupportsTwosCompEncoding						
Returns Floating-Point Values ReturnsFloats						

Channels

Table 12: DT9832 Series Channel Options

DT9832 Series	A/D	D/A	DIN	DOUT	C/T	QUAD
Number of Channels NumberOfChannels	13 or 15 ^a	2 ^b	1	1	1	1
SE Support SupportsSingleEnded	Yes					
SE Channels MaxSingleEndedChannels	2 or 4 ^a	0	0	0	0	0
DI Support SupportsDifferential		Yes	Yes	Yes	Yes	Yes
DI Channels MaxDifferentialChannels	0	2	1	1	1	1
Maximum Channel-Gain List Depth CGLDepth	13 or 15 ^a	3 ^b	1	1	0	0
Simultaneous Sample-and-Hold Support SupportsSimultaneousSampleHold	Yes					
Channel-List Inhibit SupportsChannelListInhibit						

- a. For DT9832A modules (2 channels), channels 0 to 1 read the analog input channels; channel 2 reads all 16 bits from the DIN subsystem; channels 3 to 6 read the C/T channels; and channels 7 to 12 read the quadrature decoder channels. For DT9832 modules (4 channels), channels 0 to 3 read the analog input channels; channel 4 reads all 16 bits from the DIN subsystem; channels 5 to 8 read the C/T channels; and channels 9 to 15 read the quadrature decoder channels.
- b. Analog output channels are numbered 0 and 1. You can update the digital output port by specifying channel 2 in the analog output channel list.

Gain

Table 13: DT9832 Series Gain Options

DT9832 Series	A/D	D/A	DIN	DOUT	C/T	QUAD
Programmable Gain Support SupportsProgrammableGain	Yes					
Number of Gains NumberOfSupportedGains	1	1	1	1	0	0
Gains Available SupportedGains	1	1	1	1		

Ranges

Table 14: DT9832 Series Range Options

DT9832 Series	A/D	D/A	DIN	DOUT	C/T	QUAD
Number of Voltage Ranges NumberOfRanges	1	1	0	0	0	0
Available Ranges SupportedVoltageRanges	± 10 V	± 10 V ^a				
Current Output Support SupportsCurrentOutput						

- a. For the D/A subsystem that is used as the threshold trigger, the range is 0 to 10 V, where a raw count of 0 represents 0 V and a raw count of 255 represents 10 V.

Resolution

Table 15: DT9832 Series Resolution Options

DT9832 Series	A/D	D/A	DIN	DOUT	C/T	QUAD
Software Programmable Resolution SupportsSoftwareResolution						
Number of Resolutions NumberOfResolutions	1	1	1	1	1	1
Available Resolutions SupportedResolutions	16	16 ^a	16	16	32	32

a. For the D/A subsystem that is used to set the analog threshold value, the resolution is 8-bits.

Thermocouple and RTD Support

Table 16: DT9832 Series Thermocouple and RTD Support Options

DT9832 Series	A/D	D/A	DIN	DOUT	C/T	QUAD
Thermocouple Support SupportsThernocouple						
RTD Support SupportsRTD						
Resistance Support ReturnsOhms						
Voltage Converted to Temperature in Hardware SupportsTemperatureDataInStream						
Supported Thermocouple Types ThermocoupleType						
Supported RTD Types RTDType						
Supports CJC Source Internally in Hardware SupportsCjcSourceInternal						

Table 16: DT9832 Series Thermocouple and RTD Support Options

DT9832 Series	A/D	D/A	DIN	DOUT	C/T	QUAD
Supports CJC Channel SupportsCjcSourceChannel						
Available CJC Channels CjcChannel						
Supports Interleaved CJC Values in Data Stream SupportsInterleavedCjcTemperaturesInStream						
Supports Programmable Filters SupportsTemperatureFilters						
Programmable Filter Types TemperatureFilterType						

IEPE Support

Table 17: DT9832 Series IEPE Support Options

DT9832 Series	A/D	D/A	DIN	DOUT	C/T	QUAD
Software Programmable AC Coupling SupportsACCoupling						
Software Programmable DC Coupling SupportsDCCoupling						
Software Programmable External Excitation Current Source SupportsExternalExcitationCurrent Src						
Software Programmable Internal Excitation Current Source SupportsInternalExcitationCurrentSrc						
Available Excitation Current Source Values SupportedExcitationCurrentValues						

Triggers

Table 18: DT9832 Series Trigger Options

DT9832 Series	A/D	D/A	DIN	DOUT	C/T	QUAD
Software Trigger Support SupportsSoftwareTrigger	Yes	Yes	Yes	Yes	Yes	Yes
External Positive TTL Trigger Support SupportsPosExternalTTLTrigger	Yes	Yes			Yes	Yes
External Negative TTL Trigger Support SupportsNegExternalTTLTrigger	Yes	Yes				
External Positive TTL Trigger Support for Single-Value Operations SupportsSvPosExternalTTLTrigger						
External Negative TTL Trigger Support for Single-Value Operations SupportsSvNegExternalTTLTrigger						
Positive Threshold Trigger Support SupportsPosThresholdTrigger	Yes					
Negative Threshold Trigger Support SupportsNegThresholdTrigger						
Digital Event Trigger Support SupportsDigitalEventTrigger						

Clocks

Table 19: DT9832 Series Clock Options

DT9832 Series	A/D	D/A	DIN	DOUT	C/T	QUAD
Internal Clock Support SupportsInternalClock	Yes	Yes	Yes	Yes		
External Clock Support SupportsExternalClock	Yes	Yes			Yes	Yes
Simultaneous Input/Output on a Single Clock Signal SupportsSimultaneousClocking	Yes	Yes				
Base Clock Frequency BaseClockFrequency	48 MHz	48 MHz	0	0	48 MHz	48 MHz
Maximum Clock Divider MaxExtClockDivider	0	0	1	1	2,147,483,647	2,147,483,647
Minimum Clock Divider MinExtClockDivider	0	0	1	1	2	2
Maximum Frequency MaxFrequency	1.25 or ^a 2.0 MHz	500 kHz	0	0	24 MHz	24 MHz
Minimum Frequency MinFrequency	0	0	0	0	0.0224 Hz	0.0224 Hz

- a. The DT9832 supports a maximum throughput frequency of 1.25 MHz; the DT9832A supports a maximum throughput frequency of 2.0 MHz.

Counter/Timers

Table 20: DT9832 Series Counter/Timer Options

DT9832 Series	A/D	D/A	DIN	DOUT	C/T	QUAD
Cascading Support SupportsCascading						
Event Count Mode Support SupportsCount					Yes	
Generate Rate Mode Support SupportsRateGenerate					Yes	
One-Shot Mode Support SupportsOneShot					Yes	
Repetitive One-Shot Mode Support SupportsOneShotRepeat					Yes	
Up/Down Counting Mode Support SupportsUpDown					Yes	
Edge-to-Edge Measurement Mode Support SupportsMeasure					Yes	
Continuous Edge-to-Edge Measurement Mode Support SupportsContinuousMeasure					Yes	
High to Low Output Pulse Support SupportsHighToLowPulse					Yes	
Low to High Output Pulse Support SupportsLowToHighPulse					Yes	
Variable Pulse Width Support SupportsVariablePulseWidth					Yes ^a	
None (internal) Gate Type Support SupportsGateNone					Yes	
High Level Gate Type Support SupportsGateHighLevel					Yes ^b	
Low Level Gate Type Support SupportsGateLowLevel					Yes ^b	

Table 20: DT9832 Series Counter/Timer Options (cont.)

DT9832 Series	A/D	D/A	DIN	DOUT	C/T	QUAD
High Edge Gate Type Support SupportsGateHighEdge					Yes ^b	
Low Edge Gate Type Support SupportsGateLowEdge					Yes ^b	
Level Change Gate Type Support SupportsGateLevel						
Clock-Falling Edge Type SupportsClockFalling					Yes	
Clock-Rising Edge Type SupportsClockRising					Yes	
Gate-Falling Edge Type SupportsGateFalling					Yes	
Gate-Rising Edge Type SupportsGateRising					Yes	
Interrupt-Driven Operations SupportsInterrupt						

- a. In one-shot and repetitive one-shot mode, the pulse width is set to 100% automatically.
- b. High-edge and low-edge are supported for one-shot and repetitive one-shot modes. High-level and low-level are supported for event counting, up/down counting, frequency measurement, edge-to-edge measurement, continuous edge-to-edge measurement, and rate generation modes.



Troubleshooting

General Checklist	128
Technical Support	132
If Your Module Needs Factory Service	133

General Checklist

Should you experience problems using a DT9832 Series module, do the following:

1. Read all the documentation provided for your product. Make sure that you have added any “Read This First” information to your manual and that you have used this information.
2. Check the OMNI CD for any README files and ensure that you have used the latest installation and configuration information available.
3. Check that your system meets the requirements stated in the README file on the OMNI CD.
4. Check that you have installed your hardware properly using the instructions in [Chapter 2](#).
5. Check that you have installed and configured the device driver properly using the instructions in [Chapter 2](#).
6. Check that you have wired your signals properly using the instructions in [Chapter 3](#).
7. Search the DT Knowledgebase in the Support section of the Data Translation web site (at www.datatranslation.com) for an answer to your problem.
8. Visit the product’s page on the Data Translation web site for the latest tips, white papers, product documentation, and software fixes.

If you still experience problems, try using the information in [Table 21](#) to isolate and solve the problem. If you cannot identify the problem, refer to [page 132](#).

Table 21: Troubleshooting Problems

Symptom	Possible Cause	Possible Solution
Module is not recognized	You plugged the module into your computer before installing the device driver.	From the Control Panel > System > Hardware > Device Manager, uninstall any unknown devices (showing a yellow question mark). Then, run the setup program on your OMNI CD to install the USB device drivers, and reconnect your USB module to the computer.
Module does not respond.	The module configuration is incorrect.	Check the configuration of your device driver; see the instructions in Chapter 2 .
	The module is damaged.	Contact Data Translation for technical support; refer to page 132 .
Intermittent operation.	Loose connections or vibrations exist.	Check your wiring and tighten any loose connections or cushion vibration sources; see the instructions in Chapter 3 .
	The module is overheating.	Check environmental and ambient temperature; consult the module's specifications on page 153 of this manual and the documentation provided by your computer manufacturer for more information.
	Electrical noise exists.	Check your wiring and either provide better shielding or reroute unshielded wiring; see the instructions in Chapter 3 .

Table 21: Troubleshooting Problems (cont.)

Symptom	Possible Cause	Possible Solution
Device failure error reported.	The DT9832 Series module cannot communicate with the Microsoft bus driver or a problem with the bus driver exists.	Check your cabling and wiring and tighten any loose connections; see the instructions in Chapter 3 .
	The DT9832 Series module was removed while an operation was being performed.	Ensure that your DT9832 Series module is properly connected; see the instructions in Chapter 2 .
Data appears to be invalid.	An open connection exists.	Check your wiring and fix any open connections; see the instructions in Chapter 3 .
	A transducer is not connected to the channel being read.	Check the transducer connections; see the instructions in Chapter 3 .
	The module is set up for differential inputs while the transducers are wired as single-ended inputs or vice versa.	Check your wiring and ensure that what you specify in software matches your hardware configuration; see the instructions in Chapter 3 .

Table 21: Troubleshooting Problems (cont.)

Symptom	Possible Cause	Possible Solution
Data appears to be invalid (cont.).	The DT9832 Series module is out of calibration.	DT9832 Series modules are calibrated at the factory. If you want to readjust the calibration of the analog input or analog output circuitry, refer to Chapter 8 starting on page 135 .
USB 2.0 is not recognized.	Your operating system does not have the appropriate Service Pack installed.	Ensure that you load the appropriate Windows Service Pack (version 2 for Windows XP). If you are unsure of whether you are using USB 2.0 or USB 1.1, run the Open Layers Control Panel applet, described in Chapter 2 .
	Standby mode is enabled on your PC.	For some PCs, you may need to disable standby mode on your system for proper USB 2.0 operation. Consult Microsoft for more information.

Technical Support

If you have difficulty using a DT9832 Series module, Data Translation's Technical Support Department is available to provide technical assistance.

To request technical support, go to our web site at <http://www.datatranslation.com> and click on the Support link.

When requesting technical support, be prepared to provide the following information:

- Your product serial number
- The hardware/software product you need help on
- The version of the OMNI CD you are using
- Your contract number, if applicable

If you are located outside the USA, contact your local distributor; see our web site (www.datatranslation.com) for the name and telephone number of your nearest distributor.

If Your Module Needs Factory Service

If your module must be returned to Data Translation, do the following:

1. Record the module's serial number, and then contact the Customer Service Department at (508) 481-3700, ext. 1323 (if you are in the USA) and obtain a Return Material Authorization (RMA).

If you are located outside the USA, call your local distributor for authorization and shipping instructions; see our web site (www.datatranslation.com) for the name and telephone number of your nearest distributor. All return shipments to Data Translation must be marked with the correct RMA number to ensure proper processing.

2. Using the original packing materials, if available, package the module as follows:
 - Wrap the module in an electrically conductive plastic material. Handle with ground protection. A static discharge can destroy components on the module.
 - Place in a secure shipping container.
3. Return the module to the following address, making sure the RMA number is visible on the outside of the box.

Customer Service Dept.
Data Translation, Inc.
100 Locke Drive
Marlboro, MA 01752-1192



Calibration

Using the Calibration Utility	137
Calibrating the Analog Input Subsystem	138
Calibrating the Analog Output Subsystem	141

DT9832 Series modules are calibrated at the factory and should not require calibration for initial use. We recommend that you check and, if necessary, readjust the calibration of the analog input and analog output circuitry on the DT9832 Series modules every six months using the DT9832 / DT9836 Calibration Utility.

Note: Ensure that you installed the DT9832 Series Device Driver prior to using the DT9832 / DT9836 Calibration Utility.

This chapter describes how to calibrate the analog input and output subsystems of DT9832 Series modules using the DT9832 /DT9836 Calibration Utility.

Using the Calibration Utility

Start the DT9832 / DT9836 Calibration Utility as follows:

1. Click **Start** from the Task Bar.
2. Select **Programs | Data Translation, Inc | Calibration | DT9832 Calibration Utility**.
The main menu of the DT9832 / DT9836 Calibration Utility appears.
3. Select the module to calibrate, and then click **OK**.

Once the DT9832 / DT9836 Calibration Utility is running, you can calibrate the analog input circuitry (either automatically or manually), described on [page 138](#), or the analog output circuitry of the DT9832 Series module, described on [page 141](#).

Calibrating the Analog Input Subsystem

This section describes how to use the DT9832 / DT9836 Calibration Utility to calibrate the analog input subsystem of a DT9832 Series module.

The DT9832 Series module has separate calibration for each A/D input channel. You can choose to calibrate either an individual channel or all channels on the board.

Connecting a Precision Voltage Source

To calibrate the analog input circuitry, you need to connect an external +9.3750 V precision voltage source to the DT9832 Series module. Connect the precision voltage source to the first channel you want to calibrate; for example, Analog In 0 (AD Ch0).

Using the Auto-Calibration Procedure

Auto-calibration is the easiest to use and is the recommended calibration method. To auto-calibrate the analog input subsystem, do the following:

1. Select the **A/D Calibration** tab of the DT9832 / DT9836 Calibration Utility.
2. Choose either a single channel or all channels from the **Type of Calibration** drop-down list box in the **Automatic Calibration** area.
3. Set the voltage supply on your selected channel to 0.000V.
4. Click the Auto Calibration **Start** button.
A message appears notifying you to verify that 0.000 V is applied to the channel.

5. Verify that the supplied voltage to your selected channel is 0.000 V, and then click **OK**.
The offset value is calibrated. When the offset calibration is complete, a message appears notifying you to set the input voltage of the channel to +9.375 V.
6. Check that the supplied voltage to your selected channel is +9.375 V, and then click **OK**.
The gain value is calibrated and a completion message appears.
7. If you chose to calibrate all channels, repeat the proceeding four steps for all other A/D channels on the board (the calibration utility prompts you to attach the precision voltage source to the next channel). Follow the on-screen prompts to proceed through the rest of the channels.

Note: At any time, you can click **Restore Factory Settings** to reset the A/D calibration values to their original factory settings. This process will undo any auto or manual calibration settings.

Using the Manual Calibration Procedure

If you want to manually calibrate the analog input circuitry instead of auto-calibrating it, do the following for each channel (substitute the appropriate channel number as you go):

1. Adjust the offset as follows:
 - a. Verify that 0.000 V is applied to AD Ch0, and that A/D Channel Select is set to Channel 0.
The current voltage reading for this channel is displayed in the A/D Value window.
 - b. Adjust the offset by entering values between 0 and 255 in the Offset edit box, or by clicking the up/down buttons until the A/D Value is 0.000 V.

2. Adjust the gain as follows:
 - a. Verify that +9.375 V is applied to AD Ch0, and that A/D Channel Select is set to Channel 0.
The current voltage reading for this channel is displayed in the A/D Value window.
 - b. Adjust the gain by entering values between 0 and 255 in the Gain edit box, or by clicking the up/down buttons until the A/D Value is 9.3750 V.

Note: At any time, you can click **Restore Factory Settings** to reset the A/D calibration values to their original factory settings. This process will undo any auto or manual calibration settings.

Once you have finished this procedure, continue with [“Calibrating the Analog Output Subsystem.”](#)

Calibrating the Analog Output Subsystem

This section describes how to use the DT9832 / DT9836 Calibration Utility to calibrate the analog output subsystem of a DT9832 Series module.

To calibrate the analog output circuitry, you need to connect an external precision voltmeter to analog output channels 0 and 1 of the DT9832 Series module.

Do the following to calibrate the analog output circuitry:

1. Select the **D/A Calibration** tab of the DT9832 / DT9836 Calibration Utility.
2. Connect an external precision voltmeter to Analog Output 0 (DAC Ch0) of the DT9832 Series module.
3. In the DAC Output Voltage box, select **-9.375 V**.
4. Adjust the offset by entering values between 0 and 255 in the DAC 0 Offset edit box or by clicking the up/down buttons until the voltmeter reads -9.375 V.
5. In the DAC Output Voltage box, select **9.375 V**.
6. Adjust the gain by entering values between 0 and 255 in the DAC 0 Gain edit box or by clicking the up/down buttons until the voltmeter reads 9.375 V.
7. Connect an external precision voltmeter to Analog Output 1 (DAC Ch1) of the DT9832 Series module.
8. In the DAC Output Voltage box, select **-9.375 V**.
9. Adjust the offset by entering values between 0 and 255 in the DAC 1 Offset edit box or by clicking the up/down buttons until the voltmeter reads -9.375 V.
10. In the DAC Output Voltage box, select **9.375 V**.
11. Adjust the gain by entering values between 0 and 255 in the DAC 1 Gain edit box or by clicking the up/down buttons until the voltmeter reads 9.375 V.

Note: At any time, you can click **Restore Factory Settings** to reset the D/A calibration values to their original factory settings. This process will undo any D/A calibration settings.

Once you have finished this procedure, the analog output circuitry is calibrated. To close the DT9832 / DT9836 Calibration Utility, click the close box in the upper right corner of the window.



Specifications

Table 22 lists the specifications for the A/D subsystem on the DT9832 Series modules.

Table 22: A/D Subsystem Specifications

Feature	Specifications
Number of analog input channels DT9832: DT9832A:	4 single-ended, simultaneous 2 single-ended, simultaneous
Resolution	16 bits
Range	± 10 V
Throughput per channel	See Table 23.
Signal bandwidth (to 3 dB point) DT9832: DT9832A:	>6.25 MHz >10.0 MHz
Sample-and-hold Aperture uncertainty: Aperture delay: Aperture match: Gain match: Zero match:	200 ps typical 25 ns typical 1 ns / 500 ps typical $\pm 0.015\%$ ± 1.5 mV
System accuracy, to % of FSR	$\pm 0.01\%$
Bipolar input range	± 10 V
Data encoding	Offset binary
Maximum input voltage (without damage) Power on: Power off:	± 35 V ± 20 V
Input impedance	100 M Ω , 10 pF
Input bias current	± 10 nA
Integral nonlinearity	< 2 LSB

Table 22: A/D Subsystem Specifications (cont.)

Feature	Specifications
Differential nonlinearity	< 1 LSB
Inherent quantizing error	1/2 LSB
Drift Zero: Gain:	$\pm 20 \mu\text{V}/^\circ\text{C}$ $\pm 20 \text{ ppm of FSR}/^\circ\text{C}$
ESD protection Arc: Contact:	8 kV 4 kV
Effective Number of Bits (ENOBs) @ 10 kHz input	14 bits typical
Spurious Free Dynamic Range (SFDR)	86 dB typical

A

A/D Subsystem Throughput

Due to limitations of the USB bus, the maximum achievable sample rate (throughput) of the modules depends upon the number of channels sampled. [Table 23](#) lists the approximate throughput for each module based on the number of channels in the channel list.

The maximum allowable sample rate for a given number of channels is $5,450,000 / (\text{Number of Channels})$. The sample clock is generated by dividing the 48 MHz internal clock by an even divisor. The sample rate you set with DT-Open Layers will be set to the nearest even divisor on the module.

If you set a rate that is too high, you will receive an overrun error when you begin sampling.

Table 23: Maximum Achievable Throughput

Channels	DT9832 ^a	DT9832A ^b
1	1,250,000 Hz	2,000,000 Hz
2	1,250,000 Hz	2,000,000 Hz
3	1,250,000 Hz	1,816,666 Hz
4	1,250,000 Hz	1,362,500 Hz
5	1,090,000 Hz	
6	908,333 Hz	
7	778,571 Hz	
8	681,250 Hz	
9	605,555 Hz	
10	545,000 Hz	
11	495,454 Hz	
12	454,166 Hz	
13	419,230 Hz	
14	389,286 Hz	--
15	363,333 Hz	--

- a. If you use all 15 channels of the DT9832 (30 bytes/sample), 1.25 MHz is transferred to the FIFO. The stated USB limitation applies.
- b. If you use all 13 channels of the DT9832A (26 bytes/sample), 1.50 MHz is transferred to the FIFO. The stated USB limitation applies.

Table 24 lists the specifications for the D/A subsystem on the DT9832 Series modules.



Table 24: D/A Subsystem Specifications

Feature	Specifications
Number of analog output channels	2 Simultaneous
Resolution	16 bits
Settling time to 0.01% of FSR	2.0 μ s / 1.0 μ s, 100 mV steps 5.0 μ s / 2.0 μ s, 10 V steps
Throughput	500 kSamples/s per channel
Slew rate	10 V/ μ s
Glitch energy	12 nV-s, typical (essentially glitchless)
Output range	\pm 10 V
Data encoding	Offset binary
Output current	\pm 5 mA maximum load
Output impedance	0.1 Ω maximum
Capacitive driver capability	0.004 μ F
Protection	Short circuit to analog ground
Integral nonlinearity	1.0 LSB / 1/2 LSB
Differential nonlinearity	1.0 LSB / 1/2 LSB
Inherent quantizing error	1.0 LSB / 1/2 LSB
Error	
Zero:	Adjustable to 0
Gain:	Adjustable to 0

Table 24: D/A Subsystem Specifications (cont.)

Feature	Specifications
Drift Zero (bipolar): Gain:	± 10 ppm of FSR/ $^{\circ}$ C ± 30 ppm of FSR/ $^{\circ}$ C
FIFO	128 kSamples, total
ESD protection Arc: Contact:	8 kV 4 kV

Table 25 lists the specifications for the DIN/DOOUT subsystems on the DT9832 Series modules.

A

Table 25: DIN/DOOUT Subsystem Specifications

Feature	Specifications
Number of digital I/O lines	32 (16 in, 16 out)
Number of ports	2 (16 bits each)
Logic family	LVTTL (5 V tolerant)
Logic sense	Positive true
Inputs Input type: Input logic load: High input voltage: Low input voltage: Low input current:	Level-sensitive 1 LVTTL 2.0 V minimum 0.8 V maximum 0.4 mA maximum
Input termination	Inputs tied to +3.3 V through 15 k Ω pull-up resistors
Outputs Fan out: High output: Low output: High output current: Low output current:	12 mA 2.0 V minimum 0.8 V maximum –12 mA maximum 12 mA maximum
Interrupt on change	Yes (on first 8 bits)
Clocked with sample clock	Yes
Software I/O selectable	No

Table 26 lists the specifications for the C/T and quadrature decoder subsystems on the DT9832 Series modules.

Table 26: C/T and Quadrature Decoder Subsystem Specifications

Feature	Specifications
Number of channels C/T: Quadrature decoder:	2 3
Resolution	32 bits per channel
Minimum pulse width (minimum amount of time it takes a C/T to recognize an input pulse)	55.5 ns
Logic family	LVTTTL (5 V tolerant)
Inputs Input logic load: High input voltage: Low input voltage: Low input current:	1 LVTTTL 2.0 V minimum 0.8 V maximum −0.4 mA maximum
Outputs Fan out: High output: Low output: High output current: Low output current:	12 mA 2.0 V minimum 0.8 V maximum −12 mA maximum 12 mA maximum
Internal reference clock rate	48 MHz
External clock rate	24 MHz maximum

Table 27 lists the specifications for the external A/D and D/A triggers on the DT9832 Series modules.



Table 27: External A/D and D/A Trigger Specifications

Feature	Specifications
Trigger sources Internal: External:	Software-initiated Software-selectable
Input type	Edge-sensitive
Logic family	LVTTL (5 V tolerant)
Inputs Input logic load: Input termination: High input voltage: Low input voltage: Low input current:	1 LVTTL 2.2 k Ω pull-up to +3.3 V 2.0 V minimum 0.8 V maximum –0.25 mA maximum
Minimum pulse width High: Low:	25 ns 25 ns
Triggering modes Single scan: Continuous scan: Triggered scan:	Yes Yes No

Table 28 lists the specifications for the internal A/D and D/A clocks on the DT9832 Series modules.

Table 28: Internal A/D and D/A Clock Specifications

Feature	Specifications
Reference frequency	48 MHz
Divisor range	3 to 4,294,967,295
Usable range A/D clock: D/A clock:	0.00838 Hz to 1.25 or 2.0 MHz 0.00838 Hz to 500 kHz

Table 29 lists the specifications for the external A/D and D/A clocks on the DT9832 Series modules.

Table 29: External A/D and D/A Clock Specifications

Feature	Specifications
Input type A/D: D/A:	falling edge rising edge
Logic family	LVTTL (5 V tolerant)
Inputs Input logic load: Input termination: High input voltage: Low input voltage:	1 LVTTL 2.2 k Ω pull-up to +3.3 V 2.0 V 0.8 V
Frequency	DC to 1.25 MHz or 2.0 MHz (DT9832A)
Minimum pulse width High: Low:	25 ns 25 ns

Table 30 lists the power, physical, and environmental specifications for the DT9832 Series modules.

A

Table 30: Power, Physical, and Environmental Specifications

Feature	Specifications
Power, +5 V	±5% @ 2 A maximum plus load on +5 V outputs
Physical Dimensions (OEM): Dimensions (BNC): Weight (OEM):	190 mm x 100 mm 215.9 mm x 105.9 mm x 50 mm 4.6 ounces
Environmental Operating temperature range: Storage temperature range: Relative humidity: Altitude:	0° C to 55° C -25° C to 85° C to 95%, noncondensing to 10,000 feet

Table 31 lists the mating cable connectors for the connectors on the BNC connection box, the OEM version of the DT9832 Series module, and the EP353 and EP356 accessory panels.

Table 31: Mating Cable Connectors

Module/Panel	Connector	Part Number on Module (or Equivalent)	Mating Cable Connector
BNC connection box	Analog input	AMP/Tyco AMP 5747375-8	AMP/Tyco 5-747917-2
	Digital I/O	AMP/Tyco 5747301-8	AMP/Tyco 5-747916-2
	C\T, DAC, Clk, Trig	AMP/Tyco 5747301-8	AMP/Tyco 5-747916-2
OEM version	J2	AMP/Tyco 6-104068-8	AMP/Tyco 3-111196-4 ^a
	J3	AMP/Tyco 6-104068-8	AMP/Tyco 3-111196-4 ^a
	TB1 ^b	Phoenix Contact 1707434	Phoenix Contact 1839610
EP353 accessory panel	J1	AMP/Tyco 5102321-6	AMP/Tyco 1658622-6
	J2	AMP/Tyco 5747375-8	AMP/Tyco 5-747917-2
EP356 accessory panel	J1	AMP/Tyco 5747301-8	AMP/Tyco 5-747916-2
	J2	AMP/Tyco 5747301-8	AMP/Tyco 5-747916-2

a. The mating PCB receptacle is AMP/Tyco 6-104078-3.

b. Secondary power connector.

Table 32 lists the regulatory specifications for the DT9832 Series modules.

A

Table 32: Regulatory Specifications

Feature	Specifications
Emissions (EMI)	FCC Part 15, EN55022:1994 + A1:1995 + A2:1997 VCCI, AS/NZS 3548 Class A
Immunity	EN61000-6-1:2001
RoHS (EU Directive 2002/95/EG)	Compliant (as of July 1st, 2006)



Connector Pin Assignments

OEM Version Connectors	158
BNC Box Connectors	165
EP353 Accessory Panel Connectors	169
EP356 Accessory Panel Connectors	173
EP355 Screw Terminal Assignments	177

OEM Version Connectors

This section describes the pin assignments for the J2 and J3 connectors on the OEM version of the DT9832 Series modules, as well as the secondary power connector, TB1. You can access these pins by building your own cable and screw terminal panel; refer to [Appendix A](#) for information about the required mating connectors. [Figure 25](#) shows the orientation of the pins on these connectors.

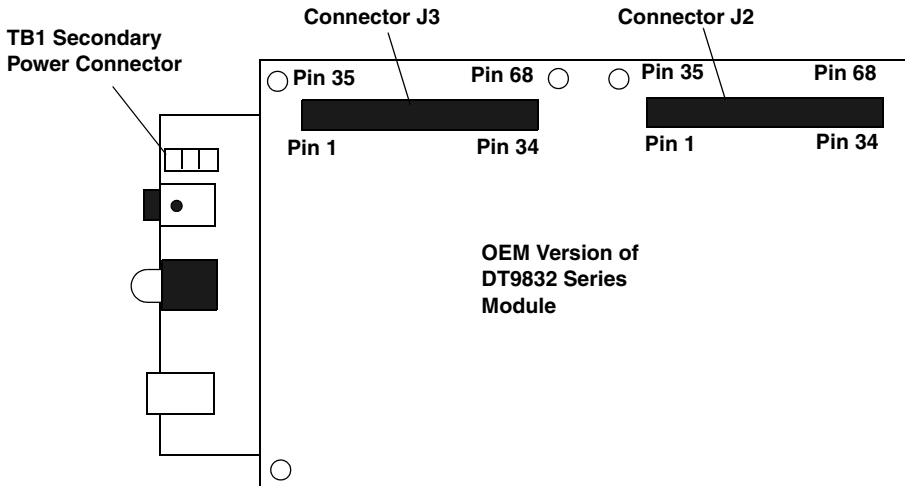

Figure 25: Connectors on OEM Version of DT9832 Module

Note: If you are using the BNC connection box, refer to [Chapter 3](#) and [“BNC Box Connectors” on page 165](#) for wiring information.

OEM J2 Connector

Table 33 lists the pin assignments for connector J2 on the OEM version of the DT9832 Series module.

Table 33: Pin Assignments for Connector J2 on the OEM Version of Module

J2 Pin Assignment	Signal Description	J2 Pin Assignment	Signal Description
1	+5 V Analog (0.5 amps)	35	Digital Ground
2	Reserved	36	Analog Ground
3	Analog Ground	37	Analog Ground
4	Reserved	38	Reserved
5	Analog Ground	39	Analog Ground
6	Reserved	40	Reserved
7	Analog Ground	41	Analog Ground
8	Reserved	42	Reserved
9	Analog Ground	43	Analog Ground
10	Reserved	44	Reserved
11	Analog Ground	45	Analog Ground
12	Reserved	46	Reserved
13	Analog Ground	47	Analog Ground
14	Reserved	48	Reserved
15	Analog Ground	49	Analog Ground
16	Reserved	50	Reserved
17	Analog Ground	51	Analog Ground
18	Reserved	52	Reserved

**Table 33: Pin Assignments for Connector J2 on the
OEM Version of Module (cont.)**

J2 Pin Assignment	Signal Description	J2 Pin Assignment	Signal Description
19	Analog Ground	53	Analog Ground
20	Reserved	54	Reserved
21	Analog Ground	55	Analog Ground
22	Reserved	56	Reserved
23	Analog Ground	57	Analog Ground
24	Reserved	58	Reserved
25	Analog Ground	59	Analog Ground
26	Reserved	60	Reserved
27	Analog Ground	61	Analog Ground
28	Analog In 3 ^a	62	Reserved
29	Analog Ground	63	Analog Ground
30	Analog In 2 ^a	64	Reserved
31	Analog Ground	65	Analog Ground
32	Analog In 1	66	Reserved
33	Analog Ground	67	Analog Ground
34	Analog In 0	68	Reserved

a. Reserved on DT9832A series modules.

OEM J3 Connector

Table 34 lists the pin assignments for connector J3 on the OEM version of the DT9832 Series module.

Table 34: Pin Assignments for Connector J3 on the OEM Version of Module

J3 Pin Assignment	Signal Description	J3 Pin Assignment	Signal Description
1	Quad 2 Index	35	Quad Dec 2 B
2	Quad Dec 2 A	36	Digital Ground
3	Quad 1 Index	37	Quad Dec 1 B
4	Quad Dec 1 A	38	Digital Ground
5	Quad 0 Index	39	Quad Dec 0 B
6	Quad Dec 0 A	40	Digital Ground
7	Counter 1 Out	41	Counter 1 Gate
8	Counter 1 Clock	42	Digital Ground
9	Counter 0 Out	43	Counter 0 Gate
10	Counter 0 Clock	44	Digital Ground
11	Digital Ground	45	Reserved
12	Digital Input 15	46	Digital Output 15
13	Digital Input 14	47	Digital Output 14
14	Digital Input 13	48	Digital Output 13
15	Digital Input 12	49	Digital Output 12
16	Digital Input 11	50	Digital Output 11
17	Digital Input 10	51	Digital Output 10
18	Digital Input 9	52	Digital Output 9

**Table 34: Pin Assignments for Connector J3 on the
OEM Version of Module (cont.)**

J3 Pin Assignment	Signal Description	J3 Pin Assignment	Signal Description
19	Digital Input 8	53	Digital Output 8
20	Digital Input 7	54	Digital Output 7
21	Digital Input 6	55	Digital Output 6
22	Digital Input 5	56	Digital Output 5
23	Digital Input 4	57	Digital Output 4
24	Digital Input 3	58	Digital Output 3
25	Digital Input 2	59	Digital Output 2
26	Digital Input 1	60	Digital Output 1
27	Digital Input 0	61	Digital Output 0
28	External ADC Clock	62	External ADC Trigger
29	External DAC Clock	63	External DAC Trigger
30	Digital Ground	64	Digital Ground
31	+5 V	65	Digital Ground
32	Reserved	66	Reserved
33	Analog Out 1 ^a	67	Analog Out 1 Return ^a
34	Analog Out 0 ^a	68	Analog Out 0 Return ^a

a. Reserved on DT9832A-02-0-OEM, DT9832A-02-0-BNC, DT9832-04-0-OEM, and DT9832-04-0-BNC modules

OEM Wiring Methods

You can connect signals directly through the J2 and J3 connectors on the OEM version of the DT9832 Series module, or you can connect signals using the connectors and screw terminals on the following accessories:

- **EP353** –This accessory panel plugs into connector J2 of the OEM version of the DT9832 Series module. It provides one 37-pin, D-sub connector for attaching analog input signals and one 26-pin connector for attaching a AC1315 cable/5B Series signal conditioning backplane.

Refer to [page 169](#) for more information about attaching the EP353 to the OEM version of the DT9832 Series module and for information about the connector pin assignments.

- **EP356** –This accessory panel plugs into connector J3 of the OEM version of the DT9832 Series module. It provides two 37-pin, D-sub connectors. Use connector J1 of the EP356 to attach digital I/O signals, and use connector J2 of the EP356 to attach analog output, counter/timer, trigger, and clock signals.

Refer to [page 173](#) for more information about attaching the EP356 to the OEM version of the DT9832 Series module and for information about the connector pin assignments.

OEM TB1 Connector

Table 35 lists the pin assignments for connector TB1 on the OEM version of the DT9832 Series modules.

Table 35: Pin Assignments for Connector TB1 on the OEM Version of Module

TB1 Pin Assignment	Signal Description
1	+5 V
2	Ground
3	Shield (Chassis Ground)

BNC Box Connectors

This section describes the pin assignments for the D-sub connectors on the BNC connection box. Note that the BNC connectors are labeled on the box.

B

Digital I/O Connector

Figure 26 shows the orientation of the pins on the Digital In/Out connector on the BNC connection box.

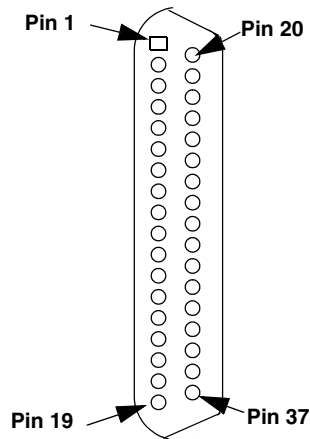

Figure 26: Orientation of the Digital In/Out Connector on the BNC Connection Box

Table 36 lists the pin assignments for the Digital In/Out connector on the BNC connection box.

**Table 36: BNC Connection Box
Digital In/Out Connector Pin Assignments**

Pin Assignment	Signal Description	Pin Assignment	Signal Description
1	Digital Input 0	20	Digital Output 0
2	Digital Input 1	21	Digital Output 1
3	Digital Input 2	22	Digital Output 2
4	Digital Input 3	23	Digital Output 3
5	Digital Input 4	24	Digital Output 4
6	Digital Input 5	25	Digital Output 5
7	Digital Input 6	26	Digital Output 6
8	Digital Input 7	27	Digital Output 7
9	Digital Input 8	28	Digital Output 8
10	Digital Input 9	29	Digital Output 9
11	Digital Input 10	30	Digital Output 10
12	Digital Input 11	31	Digital Output 11
13	Digital Input 12	32	Digital Output 12
14	Digital Input 13	33	Digital Output 13
15	Digital Input 14	34	Digital Output 14
16	Digital Input 15	35	Digital Output 15
17	Digital Ground	36	Reserved
18	Digital Ground	37	Digital Ground
19	No Connect		

CT/Enc In, Analog Out, Clk/Trig Connector

Figure 27 shows the orientation of the pins on the CT/Enc In, Analog Out, Clk/Trig connector on the BNC connection box.

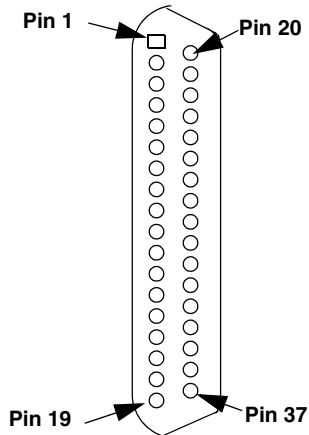

Figure 27: Orientation of the CT/Enc In, Analog Out, Clk/Trig Connector on the BNC Connection Box

Table 37 lists the pin assignments for the CT/Enc In, Analog Out, Clk/Trig connector on the BNC connection box.

B

Table 37: BNC Connection Box CT/Enc In, Analog Out, Clk/Trig Connector Pin Assignments

Pin Assignment	Signal Description	Pin Assignment	Signal Description
1	Analog Output 0 ^a	20	Analog Output 0 Return ^a
2	Analog Output 1 ^a	21	Analog Output 1 Return ^a
3	Reserved	22	Reserved
4	Reserved	23	Reserved
5	Digital Ground	24	Digital Ground
6	External DAC Clock	25	External DAC Trigger
7	External ADC Clock	26	External ADC Trigger
8	Counter 0 Clock	27	Digital Ground
9	Counter 0 Out	28	Counter 0 Gate
10	Counter 1 Clock	29	Digital Ground
11	Counter 1 Out	30	Counter 1 Gate
12	Quad Dec 0 A	31	Digital Ground
13	Quad 0 Index	32	Quad Dec 0 B
14	Quad Dec 1 A	33	Digital Ground
15	Quad 1 Index	34	Quad Dec 1 B
16	Quad Dec 2 A	35	Digital Ground
17	Quad 2 Index	36	Quad Dec 2 B
18	Digital Ground	37	Digital Ground
19	No Connect		

a. Reserved on DT9832A-02-0-OEM, DT9832A-02-0-BNC, DT9832-04-0-OEM, and DT9832-04-0-BNC modules.

EP353 Accessory Panel Connectors

To attach an EP353 accessory panel to the OEM version of the DT9832 Series module, plug the EP353 panel into connector J2 on the module, as shown in [Figure 28](#).

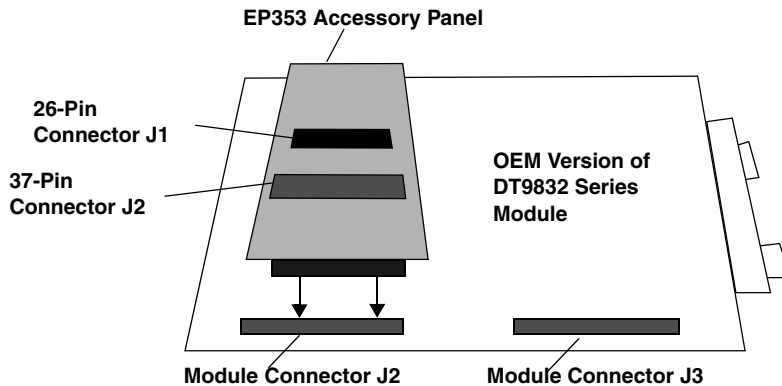

Figure 28: Connecting the EP353 Accessory Panel to Connector J2

Connector J1

[Figure 29](#) shows the orientation of the pins for connector J1 on the EP353 panel.

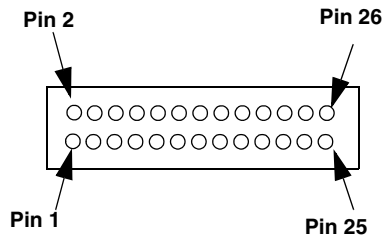

Figure 29: Orientation of the Pins for Connectors J1 on the EP353 Panel

You can use connector J1 and an AC1315 cable to attach a 5B Series signal conditioning backplane to the EP353 accessory panel.

Table 38 lists the pin assignments for connector J1 on the EP353 accessory panel.

Table 38: EP353 Connector J1 Pin Assignments

J1 Pin Assignment	Signal Description	J1 Pin Assignment	Signal Description
1	Analog Input 0	2	Reserved
3	Analog Ground	4	Reserved
5	Analog Input 1	6	Analog Ground
7	Analog Input 2 ^a	8	Reserved
9	Analog Ground	10	Reserved
11	Analog Input 3 ^a	12	Analog Ground
13	Reserved	14	Reserved
15	Analog Ground	16	Reserved
17	Reserved	18	Analog Ground
19	Reserved	20	Reserved
21	Analog Ground	22	Reserved
23	Reserved	24	Analog Ground
25	Reserved	26	Reserved

a. Reserved on DT9832A Series modules.

Connector J2

Use EP353 connector J2 to attach analog input signals to the EP353 accessory panel. [Figure 30](#) shows the orientation of the pins for connector J2 on the EP353 panel.

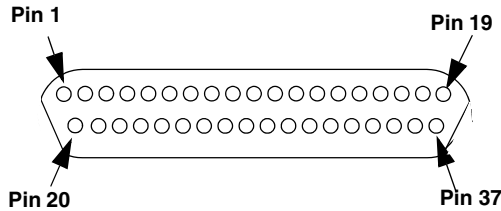

Figure 30: Orientation of the Pins for Connectors J2 on the EP353 Panel

You can access the pins on connector J2 either by using the EP360 cable and STP37 screw terminal panel (available from Data Translation) or by building your own cable/panel. Refer to [Appendix A](#) for information about the required mating connectors.

[Table 39](#) lists the pin assignments of connector J2 on the EP353 accessory panel.

Table 39: EP353 Connector J2 Pin Assignments

J2 Pin Assignment	Signal Description	J2 Pin Assignment	Signal Description
1	Analog Input 0	20	Reserved
2	Analog Input 1	21	Reserved
3	Analog Input 2 ^a	22	Reserved
4	Analog Input 3 ^a	23	Reserved
5	Reserved	24	Reserved
6	Reserved	25	Reserved
7	Reserved	26	Reserved
8	Reserved	27	Reserved
9	Reserved	28	Reserved
10	Reserved	29	Reserved
11	Reserved	30	Reserved
12	Reserved	31	Reserved
13	Reserved	32	Reserved
14	Reserved	33	Reserved
15	Reserved	34	Reserved
16	Reserved	35	Reserved
17	Reserved	36	Analog Ground
18	+5 V Analog	37	Digital Ground
19	Chassis Ground		

a. Reserved on DT9832A Series modules.

EP356 Accessory Panel Connectors

To attach an EP356 accessory panel to the OEM version of the DT9832 Series module, plug the EP356 panel into connector J3 on the module, as shown in [Figure 31](#).

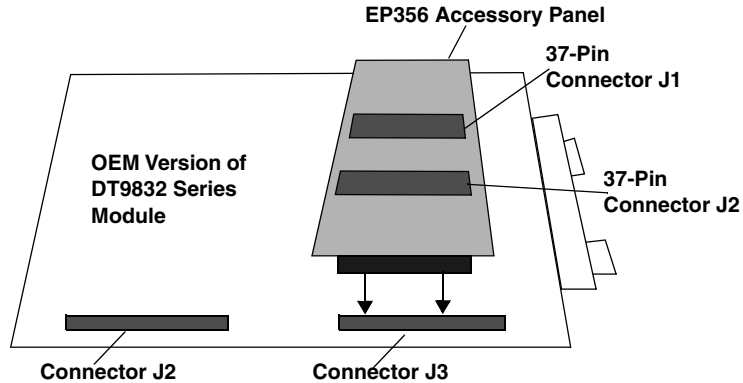

Figure 31: Connecting the EP356 Panel to the OEM Module

[Figure 32](#) shows the orientation of the pins for connectors J1 and J2 on the EP356 panel.

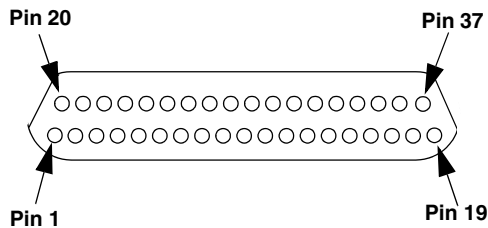

Figure 32: Orientation of the Pins for Connectors J1 and J2 of the EP356 Panel

Connector J1

Use connector J1 on the EP356 accessory panel to attach digital I/O signals. You can access the pins on the connector J1 either by using the EP333 cable and STP37 screw terminal panel (available from Data Translation) or by building your own cable/panel. To build your own cable/panel, refer to [Appendix A](#) for information about the required mating connectors.

[Table 40](#) lists the pin assignments for connector J1 on the EP356 panel.

Table 40: EP356 Connector J1 Pin Assignments

J1 Pin Assignment	Signal Description	J1 Pin Assignment	Signal Description
1	Digital Input 0	20	Digital Output 0
2	Digital Input 1	21	Digital Output 1
3	Digital Input 2	22	Digital Output 2
4	Digital Input 3	23	Digital Output 3
5	Digital Input 4	24	Digital Output 4
6	Digital Input 5	25	Digital Output 5
7	Digital Input 6	26	Digital Output 6
8	Digital Input 7	27	Digital Output 7
9	Digital Input 8	28	Digital Output 8
10	Digital Input 9	29	Digital Output 9
11	Digital Input 10	30	Digital Output 10
12	Digital Input 11	31	Digital Output 11
13	Digital Input 12	32	Digital Output 12
14	Digital Input 13	33	Digital Output 13

Table 40: EP356 Connector J1 Pin Assignments (cont.)

J1 Pin Assignment	Signal Description	J1 Pin Assignment	Signal Description
15	Digital Input 14	34	Digital Output 14
16	Digital Input 15	35	Digital Output 15
17	Digital Ground	36	Reserved
18	Digital Ground	37	Digital Ground
19	Chassis Ground		

Connector J2

Use connector J2 on the EP356 accessory panel to attach analog output, counter/timer, trigger, and clock signals. You can access the pins on the connector J1 either by using the EP333 cable and STP37 screw terminal panel (available from Data Translation) or by building your own cable/panel. To build your own cable/panel, refer to [Appendix A](#) for information about the required mating connectors.

[Table 41](#) lists pin assignments for connector J2 on the EP356 panel.

Table 41: EP356 Connector J2 Pin Assignments

J2 Pin Assignment	Signal Description	J2 Pin Assignment	Signal Description
1	Analog Output 0 ^a	20	Analog Output 0 Return ^a
2	Analog Output 1 ^a	21	Analog Output 1 Return ^a
3	Reserved	22	Reserved
4	+5 V	23	Digital Ground
5	Digital Ground	24	Digital Ground
6	External DAC Clock	25	External DAC Trigger
7	External ADC Clock	26	External ADC Trigger
8	Counter 0 Clock	27	Digital Ground
9	Counter 0 Out	28	Counter 0 Gate
10	Counter 1 Clock	29	Digital Ground
11	Counter 1 Out	30	Counter 1 Gate
12	Quad Dec 0 A	31	Digital Ground
13	Quad 0 Index	32	Quad Dec 0 B
14	Quad Dec 1 A	33	Digital Ground
15	Quad 1 Index	34	Quad Dec 1 B
16	Quad Dec 2 A	35	Digital Ground
17	Quad 2 Index	36	Quad Dec 2 B
18	Digital Ground	37	Digital Ground
19	Chassis Ground		

a. Reserved on DT9832A-02-0-OEM, DT9832A-02-0-BNC, DT9832-04-0-OEM, and DT9832-04-0-BNC modules

EP355 Screw Terminal Assignments

The EP355 screw terminal panel is used with the OEM version of the DT9832 Series module on connector J3 of the module.

The screw terminal assignments correspond to the pin assignments on the J3 connector on the OEM version of the DT9832 Series module itself. Refer to [Table 34](#) on [page 161](#), using the pin numbers to reference the screw terminals on the EP355.

B



Ground, Power, and Isolation

Secondary Power Connector	180
Ground, Power, and Isolation Connections	181

Secondary Power Connector

The OEM version of the DT9832 Series module provides a secondary power connector, which is useful for embedded applications. The location of the connector is shown in [Figure 33](#).

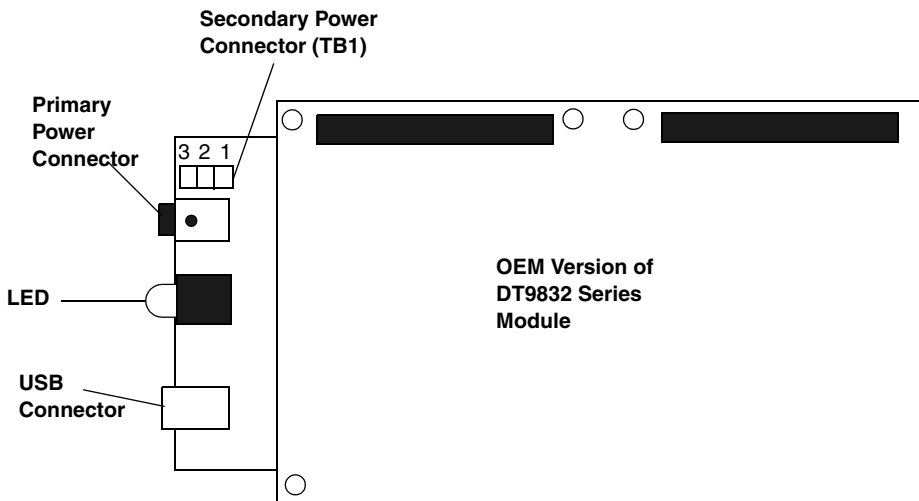

Figure 33: Secondary Power Connector

The pin assignments for the secondary power connector (TB1) are as follows:

- **Pin 1** = +5 V
- **Pin 2** = Ground
- **Pin 3** = Shield (chassis ground)

Ground, Power, and Isolation Connections

Figure 34 illustrates how ground, power, and isolation are connected on a DT9832 Series module.

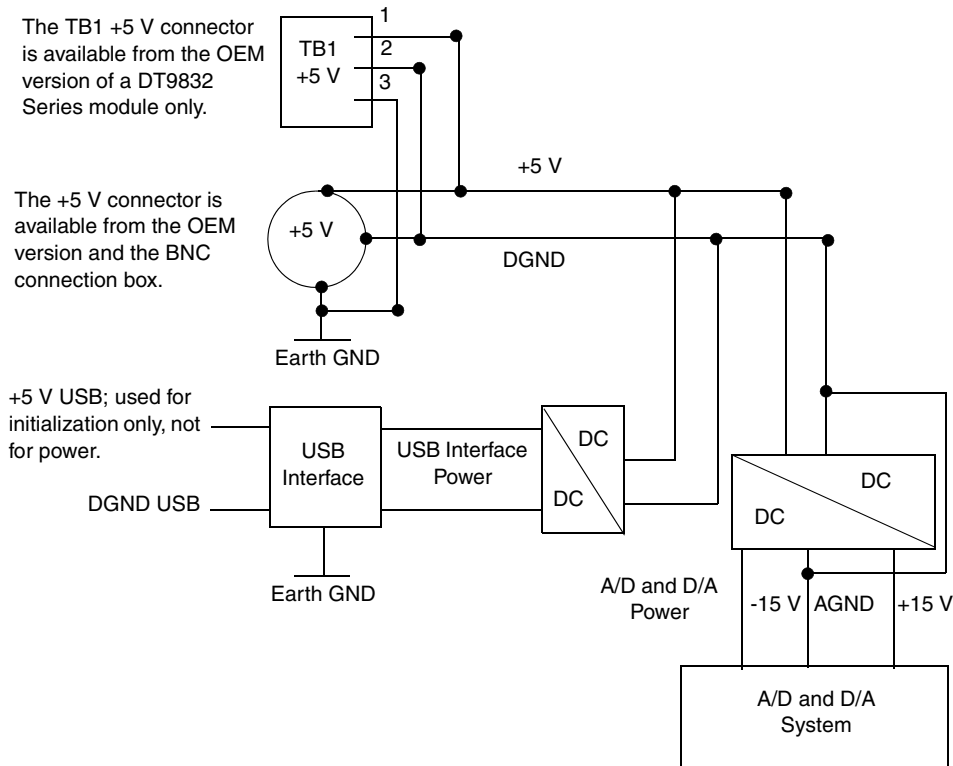

Figure 34: Ground, Power, and Isolation Connections



Keep the following in mind:

- Earth ground on the DT9832 Series module is not connected to DGND or AGND.
- Earth ground is connected to the aluminum case of the BNC connection box.
- You should connect earth ground to the power supply earth.
- You should isolate the +5V/DGND input. Note that the EP361 power supply (shipped with the BNC connection box and available from Data Translation for the OEM version of the module) has no connection between +5V/DGND and earth ground.
- The USB connector case is connected to earth ground.
- The USB data lines and USB GND are not connected to earth ground.
- The USB DGND is connected to the USB GND of the PC USB port.

Index

A

- A/D subsystem specifications [144](#)
- accessories [23](#)
- aliasing [78](#)
- analog input
 - adding a digital input port to the channel list [75](#)
 - adding counter/timers to the channel list [75](#)
 - adding quadrature decoders to the channel list [76](#)
 - calibrating [138](#)
 - channel list [74](#)
 - channels [73](#)
 - continuous operations [79](#)
 - conversion modes [79](#)
 - data format and transfer [82](#)
 - error conditions [83](#)
 - ranges [78](#)
 - resolution [73](#)
 - sample clock sources [78](#)
 - single-ended operations [79](#)
 - testing continuous [64](#)
 - testing single-value [62](#)
 - triggers [81](#)
 - wiring single-ended inputs [47](#)
- analog output
 - calibrating [141](#)
 - channel list [85](#)
 - channels [84](#)
 - clock sources [87](#)
 - conversion modes [87](#)
 - data format and transfer [90](#)
 - error conditions [91](#)
 - gain [86](#)
 - ranges [86](#)
 - resolution [84](#)
 - single-value operations [87](#)
 - streaming operations [87](#)
 - subsystem specifications [147](#)
 - testing [63](#)
 - wiring [48](#)
- analog threshold trigger [82](#)
- applet, Open Layers Control Panel [94](#), [131](#)
- application wiring
 - analog inputs [47](#)
 - analog outputs [48](#)
 - continuous edge-to-edge measurement [55](#)
 - digital inputs and outputs [49](#)
 - edge-to-edge measurement [54](#)
 - event counting [50](#)
 - frequency measurement [53](#)
 - period measurement [53](#)
 - pulse output [56](#)
 - pulse width measurement [53](#)
 - up/down counting [52](#)
- applications
 - LV-Link [22](#)
 - Measure Foundry [21](#)
 - Quick DataAcq [21](#)

B

- base clock frequency [123](#)
- BaseClockFrequency [123](#)
- binary data encoding [117](#)
- BNC connection box connector pin assignments [165](#)
- buffers [83](#), [88](#), [90](#), [116](#)
 - inprocess flush [116](#)
 - single wrap mode [116](#)

C

- C/C++ programs [22](#)
- C/T, *see* counter/timer [150](#)
- cables, USB [32](#), [33](#)
- calibrating the module
 - analog input subsystem [138](#)
 - analog output subsystem [141](#)
 - running the calibration utility [137](#)
- CGLDepth [118](#)
- channel list
 - for analog input channels [74](#)
 - for counter/timers [75](#)
 - for digital input port [75](#)
 - for quadrature decoders [76](#)
- channel type
 - differential [118](#)
 - single-ended [118](#)
- channel-gain list depth [118](#)
- channels
 - analog input [73](#)
 - analog output [84](#)
 - counter/timer [95](#)
 - digital I/O [92](#)
 - number of [118](#)
 - quadrature decoder [109](#)

- clock sources
 - analog input [78](#)
 - analog output [87](#)
 - counter/timer [96](#)
 - quadrature decoder [110](#)
- clock-falling edge type [125](#)
- clock-rising edge type [125](#)
- clocks
 - base frequency [123](#)
 - external [123](#)
 - internal [123](#)
 - maximum external clock divider [123](#)
 - maximum throughput [123](#)
 - minimum external clock divider [123](#)
 - minimum throughput [123](#)
 - simultaneous [123](#)
 - specifications [152](#)
- connecting signals
 - analog inputs [47](#)
 - analog outputs [48](#)
 - continuous edge-to-edge measurement [55](#)
 - digital inputs and outputs [49](#)
 - edge-to-edge measurement [54](#)
 - event counting [50](#)
 - frequency measurement [53](#)
 - period measurement [53](#)
 - pulse output [56](#)
 - pulse width measurement [53](#)
 - up/down counting [52](#)
- connecting to the host computer [31](#)
- connector J1 pin assignments
 - EP353 [170](#)
 - EP356 [174](#)
- connector J2 pin assignments
 - EP353 [172](#)
 - EP356 [45](#), [176](#)

- OEM version 159
 - connector J3 pin assignments, OEM version 161
 - connector pin assignments
 - BNC connection box 165
 - connector TB1 pin assignments, OEM version 164
 - continuous analog input
 - post-trigger 115
 - scan operations 79
 - continuous analog output 115
 - streaming 88
 - waveform generation mode 89
 - continuous counter/timer 115
 - continuous digital I/O 93, 115
 - continuous edge-to-edge
 - measurement mode 104, 124
 - wiring 55
 - Control Panel applet 94, 131
 - conventions used 13
 - conversion modes
 - continuous analog input (scan mode) 79
 - digital I/O 93
 - single-value analog input 79
 - single-value analog output 87
 - streaming analog output 87
 - conversion rate 80
 - counter/timer
 - channels 95, 118
 - clock sources 96, 123
 - clock-falling edge type 125
 - clock-rising edge type 125
 - continuous edge-to-edge
 - measurement mode 124
 - edge-to-edge measurement mode 124
 - event counting 124
 - gate types 97
 - gate-falling edge type 125
 - gate-rising edge type 125
 - high-edge gate type 125
 - high-level gate type 124
 - high-to-low output pulse 124
 - in analog input channel list 75
 - internal gate type 124
 - low-edge gate type 125
 - low-level gate type 124
 - low-to-high output pulse 124
 - one-shot mode 124
 - rate generation mode 124
 - repetitive one-shot mode 124
 - subsystem specifications 150
 - up/down counting 124
 - variable pulse width 124
 - wiring edge-to-edge signals 54, 55
 - wiring event counting signals 50
 - wiring frequency measurement signals 53
 - wiring period signals 53
 - wiring pulse width signals 53
 - wiring up/down counting signals 52
 - counter/timers
 - connecting frequency measurement signals 53
 - connecting pulse output signals 56
 - wiring pulse output signals 56
 - counting events 100
 - customer service 133
- ## D
- D/A, *see* analog output 147
 - data encoding 82, 90, 117

- data flow modes
 - continuous C/T 115
 - continuous digital input 115
 - continuous post-trigger 115
 - single-value 115
 - data format and transfer
 - analog input 82
 - analog output 90
 - DataAcq SDK 22
 - device driver 21, 36
 - differential channels 118
 - digital I/O 92
 - adding a digital input port to the analog input channel list 75
 - adding a digital output port to the analog output channel list 85
 - input operations 93
 - lines 92
 - operation modes 93
 - output operations 93
 - single-value operations 93
 - subsystem specifications 149
 - testing inputs 65
 - testing outputs 66
 - wiring 49
 - Digital In/Out connector pin assignments 44
 - digital trigger 82, 86
 - DT-Open Layers for .NET Class Library 21
 - DTx-EZ 22
 - duty cycle 98
- E**
- edge type
 - clock falling 125
 - clock rising 125
 - gate falling 125
 - gate rising 125
 - edge-to-edge measurement mode 102, 124
 - wiring 54
 - encoding data 82, 90
 - environmental specifications 153
 - EP353 pin assignments 170, 172
 - EP355 screw terminal 177
 - EP356 pin assignments 45, 174, 176
 - errors
 - analog input 83
 - analog output 91
 - event counting 100, 124
 - wiring 50
 - expansion hub 33
 - external clock 96, 123
 - external clock divider
 - maximum 123
 - minimum 123
 - external negative digital trigger 82, 86, 122
 - external positive digital trigger 82, 86, 122

F

- factory service 133
- features 18
- FifoSize 115
- formatting data
 - analog input 82
 - analog output 90
- frequency
 - base clock 123
 - external A/D clock 78

external C/T clock 96
 external DAC clock 87
 internal A/D clock 78, 123
 internal A/D sample clock 123
 internal C/T clock 96, 123
 internal DAC clock 87
 internal retrigger clock 117
 output pulse 103
 frequency measurement 53, 67, 101

G

gain
 actual available 119
 analog output 86
 number of 119
 programmable 119
 gate type 97
 high-edge 125
 high-level 124
 internal 124
 low-edge 125
 low-level 124
 gate-falling edge type 125
 gate-rising edge type 125
 generating pulses 105, 106, 107
 ground 181

H

hardware features 18
 help, online 61
 high-edge gate type 125
 high-level gate type 124
 hot-swapping 31

I

index mode 110
 inprocess buffers 116
 input
 channels 73
 ranges 78
 resolution 73
 sample clock sources 78
 installing the Quick DataAcq
 application 61
 internal
 clock 96, 123
 gate type 124
 interrupt-on-change 94, 115
 interrupts 115
 isolation 181

J

J1 connector pin assignments
 EP353 170
 EP356 174
 J2 connector pin assignments
 EP353 172
 EP356 45, 176
 OEM version 159
 J3 connector pin assignments
 OEM version 161

L

LabVIEW 22
 LED 32, 33
 LEDs 33, 34
 lines, digital I/O 92
 low-edge gate type 125
 low-level gate type 124

LV-Link [22](#)

M

MaxDifferentialChannels [118](#)
MaxExtClockDivider [123](#)
MaxFrequency [123](#)
MaxMultiScanCount [117](#)
MaxRetriggerFreq [117](#)
MaxSingleEndedChannels [118](#)
Measure Foundry [21](#)
measuring frequency [101](#)
measuring pulses [102](#), [104](#)
MinExtClockDivider [123](#)
MinFrequency [123](#)
MinRetriggerFreq [117](#)
multiple channels
 analog input [74](#)
 analog output [85](#)

N

number of
 differential channels [118](#)
 gains [119](#)
 I/O channels [118](#)
 resolutions [120](#)
 scans per trigger [117](#)
 single-ended channels [118](#)
 voltage ranges [119](#)
NumberOfChannels [118](#)
NumberOfRanges [119](#)
NumberOfResolutions [120](#)
NumberOfSupportedGains [119](#)
Nyquist Theorem [78](#)

O

OEM version
 connector J2 pin assignments [159](#)
 connector J3 pin assignments [161](#)
 connector TB1 pin assignments [164](#)
one-shot pulse output [106](#), [124](#)
online help [61](#)
Open Layers Control Panel applet [94](#),
 [131](#)
operation modes
 continuous analog input (scan mode)
 [79](#)
 continuous digital I/O [93](#)
 single-value analog input [79](#)
 single-value analog output [87](#)
 single-value digital I/O [93](#)
 waveform generation [89](#)
output
 channel list [85](#)
 clock sources [87](#)
 pulses [124](#)
 ranges [86](#)
outputting pulses [56](#), [105](#), [106](#), [107](#)
testing [68](#)

P

period [103](#)
period measurement, wiring [53](#)
physical specifications [153](#)
pin assignments
 Digital In/Out connector [44](#)
 EP353 [170](#), [172](#)
 EP356 [45](#), [174](#), [176](#)
 OEM version connector J2 [159](#)
 OEM version connector J3 [161](#)
 OEM version connector TB1 [164](#)

ports, digital I/O 92
 positive threshold trigger 122
 post-trigger acquisition mode 115
 power 30, 180, 181
 power specifications 153
 power supply 30
 preparing to wire signals 39
 pre-scale value 110
 pulse output
 one-shot 106
 rate generation 105
 repetitive one-shot 107
 testing 68
 types 98
 wiring 56
 pulse width 98, 103
 wiring 53

Q

quadrature decoder
 adding to the analog input channel
 list 76
 features 109
 specifications 150
 wiring 58
 Quick DataAcq application 21
 installing 61
 running 61
 quickDAQ 21

R

ranges
 analog input 78
 analog output 86
 number of 119

rate generation 105, 124
 recommendations for wiring 39
 related documents 14
 repetitive one-shot pulse output 107,
 124
 resolution
 analog input 73
 analog output 84
 available 120
 number of 120
 retrigger clock frequency 117
 returning boards to the factory 133
 RMA 133

S

sample clock sources 78
 sample rate 80
 scaling mode 110
 scan operations, analog input 79
 screw terminal assignments, EP355 177
 SDK 22
 simultaneous clocking 123
 simultaneous sample-and-hold
 support 118
 simultaneous start list 115
 single buffer wrap mode 116
 single channel
 analog input 74
 analog output 85
 single-ended channels 118
 number of 118
 single-value operations 115
 analog input 79
 analog output 87
 digital I/O 93
 software trigger 82, 86, 122

- specifications 143
 - analog input 144
 - analog output 147
 - clocks 152
 - counter/timer 150
 - digital I/O 149
 - environmental 153
 - physical 153
 - power 153
 - quadrature decoder 150
 - regulatory 155
 - triggers 151
 - stopping an operation 81, 89
 - SupportedGains 119
 - SupportedResolutions 120
 - SupportedVoltageRanges 119
 - SupportsBinaryEncoding 117
 - SupportsBuffering 116
 - SupportsClockFalling 125
 - SupportsClockRising 125
 - SupportsContinuous 115
 - SupportsContinuousMeasure 124
 - SupportsCount 124
 - SupportsDifferential 118
 - SupportsExternalClock 123
 - SupportsGateFalling 125
 - SupportsGateHighEdge 125
 - SupportsGateHighLevel 124
 - SupportsGateLowEdge 125
 - SupportsGateLowLevel 124
 - SupportsGateNone 124
 - SupportsGateRising 125
 - SupportsHighToLowPulse 124
 - SupportsInProgressFlush 116
 - SupportsInternalClock 123
 - SupportsInterruptOnChange 115
 - SupportsLowToHighPulse 124
 - SupportsMeasure 124
 - SupportsNegExternalTTLTrigger 122
 - SupportsOneShot 124
 - SupportsOneShotRepeat 124
 - SupportsPosExternalTTLTrigger 122
 - SupportsPosThresholdTrigger 122
 - SupportsProgrammableGain 119
 - SupportsRateGenerate 124
 - SupportsSimultaneousClocking 123
 - SupportsSimultaneousSampleHold 118
 - SupportsSimultaneousStart 115
 - SupportsSingleEnded 118
 - SupportsSingleValue 115
 - SupportsSoftwareTrigger 122
 - SupportsUpDown 124
 - SupportsVariablePulseWidth 124
 - SupportsWrapSingle 116
- ## T
- TB1 connector pin assignments
 - OEM version 164
 - technical support 132
 - threshold trigger
 - positive 122
 - throughput
 - maximum 123
 - minimum 123
 - transferring data
 - analog input 82
 - analog output 90
 - triggered scan
 - number of scans per trigger 117
 - retrigger frequency 117
 - triggers
 - analog input 81

- analog threshold [82](#)
- external [82](#), [86](#)
- external negative digital [122](#)
- external positive digital [122](#)
- positive analog threshold [122](#)
- software [82](#), [86](#), [122](#)
- specifications [151](#)
- troubleshooting
 - procedure [128](#)
 - technical support [132](#)
 - troubleshooting table [129](#)
- TTL trigger [82](#), [86](#)

U

- units, counter/timer [95](#)
- unpacking [29](#)
- up/down counting [100](#), [124](#)
 - wiring [52](#)
- USB cable [32](#), [33](#)
- USB expansion hub [33](#)

V

- variable pulse width [124](#)
- Visual Basic for .NET programs [21](#)
- Visual Basic programs [22](#)
- Visual C# programs [21](#)
- Visual C++ programs [22](#)
- voltage ranges [78](#), [119](#)
 - number of [119](#)

W

- waveform generation mode [89](#)
- wiring signals
 - analog outputs [48](#)

- continuous edge-to-edge
 - measurement [55](#)
- digital inputs and outputs [49](#)
- edge-to-edge measurement [54](#)
- event counting [50](#)
- frequency measurement [53](#)
- period measurement [53](#)
- preparing [39](#)
- pulse output [56](#)
- pulse width measurement [53](#)
- recommendations [39](#)
- single-ended analog inputs [47](#)
 - to the BNC connection box [40](#)
- up/down counting [52](#)
- writing programs in
 - C/C++ [22](#)
 - Visual Basic [22](#)
 - Visual Basic .NET [21](#)
 - Visual C# [21](#)
 - Visual C++ [22](#)

