

INSTRUCTION MANUAL
REMOTE CONTROL SYSTEM 3

RC-3

Foreword

Thank you for purchasing the Topcon RC-3 Remote control system-3.

For the best performance of the instrument, please read these brief instructions carefully, and keep them in a convenient location for future reference.

This system has the following features:

- Enables optical communications between the total station GTS-900A, GPT-9000A and RC-3 on the prism side, which allows simplified one-man survey based on the application programs.
- Has the turn-round function with which more efficient one-man survey is possible.

General Handling Precautions

Before starting work or operation, be sure to check that this system is functioning correctly with normal performance.

- Do not submerge the instrument into water.

The instrument can not be submerged underwater.

RC-3 is designed based on the International Standard IP65 and RC-3H is designed based on the International Standard IP54, therefore it is protected from the normal rainfall.

- Guarding the instrument against shocks.

When transporting the instrument, provide some protection to minimize the risk of shocks. Heavy shocks may cause the measurement to be faulty.

- Battery level check.

Confirm battery remaining level before operating.

- Storing the instrument for long period

Remove the battery from the instrument when you would not use it for long period.

- Turn-round motions and Optical communications

RC-3 should be kept aiming so that the total station always stays within the above range of laser beam emission until the turn-round motions or optical communications are completed.



If the aiming is out of above range while RC-3R is in turn-round motions or optical communications, the turn-round or optical communications could not be completed.

See "Light emitting angle" on page 14 and "Light detecting range" on page 15.

Safety Information

In order to encourage the safe use of products and prevent any danger to the operator and others or damage to properties, important warnings are put on the products and inserted in the instruction manuals.

We suggest that everyone understand the meaning of the following displays and icons before reading the "Safety Cautions" and text.

Display	Meaning
 WARNING	Ignoring or disregard of this display may lead to death or serious injury.
 CAUTION	Ignoring or disregard of this display may lead to personal injury or physical damage to the instrument.

Injury refers to hurt, burn, electric shock, etc.

Physical damage refers to extensive damage to buildings or equipment and furniture.

Safety Cautions

 WARNING
<ul style="list-style-type: none"> • There is a risk of fire, electric shock or physical harm if you attempt to disassemble or repair the instrument yourself. This is only to be carried out by TOPCON or an authorized dealer, only!
<ul style="list-style-type: none"> • Risk of fire or electric shock. Do not use damaged power cable, plug and socket.
<ul style="list-style-type: none"> • Risk of fire or electric shock. Do not use a wet battery or charger.
<ul style="list-style-type: none"> • May ignite explosively. Never use an instrument near flammable gas, liquid matter, and do not use in a coal mine.
<ul style="list-style-type: none"> • Battery can cause explosion or injury. Do not dispose in fire or heat.
<ul style="list-style-type: none"> • The short circuit of a battery can cause a fire. Do not short circuit battery when storing it.

 CAUTION
Use of controls or adjustment or performance of procedures other than those specified herein may result in hazardous radiation exposure.
Do not allow skin or clothing to come into contact with acid from the batteries, if this does occur then wash off with copious amounts of water and seek medical advice.
Risk of injury by falling down the instrument or case. Do not use a carrying case with a damaged which belts, grips or latches.
It could be dangerous if the instrument falls over, please check that you fix the handle to the instrument.

User

- 1) This product is for professional use only!
The user is required to be a qualified surveyor or have a good knowledge of surveying, in order to understand the user and safety instructions, before operating, inspecting or adjusting.
- 2) Wear the required protectors (safety shoes, helmet, etc.) when operating.

Exceptions from Responsibility

- 1) The user of this product is expected to follow all operating instructions and make periodic checks of the product's performance.
- 2) The manufacturer, or its representatives, assumes no responsibility for results of a faulty or intentional usage or misuse including any direct, indirect, consequential damage, and loss of profits.
- 3) The manufacturer, or its representatives, assumes no responsibility for consequential damage, and loss of profits by any disaster, (an earthquake, storms, floods etc.). A fire, accident, or an act of a third party and/or a usage any other usual conditions.
- 4) The manufacturer, or its representatives, assumes no responsibility for any damage, and loss of profits due to a change of data, loss of data, an interruption of business etc., caused by using the product or an unusable product.
- 5) The manufacturer, or its representatives, assumes no responsibility for any damage, and loss of profits caused by usage except for explained in the user manual.
- 6) The manufacturer, or its representatives, assumes no responsibility for damage caused by wrong movement, or action due to connecting with other products.

Laser Safety

This product uses the invisible laser beam to communicate. This product is manufactured and sold in accordance with "Performance Standards for Light-Emitting Products" (FDA/BRH 21 CFR 1040) or "Radiation Safety of Laser Products, Equipment Classification, Requirements and User's Guide" (IEC Publication 825) provided on the safety standards for laser beam.

As per the said standard, this product is classified as "Class 1 (I) Laser Products".

This is simple a product to operating that is not required to training from a "Laser safety officer". In case of any failure, do not disassemble the instrument. Contact TOPCON or your TOPCON dealer.

Class 1 Laser Product

Invisible Laser Beam

Total Station GTS-900A, GPT-9000A series

The software must be of the correct version for your version of the GTS-900A, GPT-9000A series, otherwise the RC-3 will not function properly. Contact TOPCON or your TOPCON dealer for version information.

Contents

Foreword	1
General Handling Precautions	1
Safety Information	2
Safety Cautions	2
User	3
Exceptions from Responsibility	3
Laser Safety	3
Total Station GTS-900A, GPT-9000A series	3
Contents	4
Nomenclature and Functions	5
Remote Controller RC-3R	5
Remote Controller Handle Unit RC-3H	7
Preparation	8
Battery installation and replacement	8
Installing RC-3R onto the prism unit A6R	9
Communication between the RC-3 and a data collector	10
Mounting remote controller handle unit RC-3H onto the total station	10
Basic Operation	11
Power switch ON	11
Battery Remaining Display	11
Battery Warning Display for RC-3R	11
Battery Warning for GTS-900A, GPT-9000A series	11
Auto Power Off	11
Error display	11
Setting for Optical communications with total station	12
Table of item to be set	13
Light emitting angle	14
Light detecting range	15
Turn-round function	16
Stopping turn-around operations	17
Low Power mode of Laser Beam	17
Reference : Turn-round motions:	17
Setting Mode	18
Setting Items	18
How to Set	18
Communication Baud Rate	19
Power Source and Charging	20
Special Accessories	21
Precaution	22
Specifications	23

Nomenclature and Functions

Remote Controller RC-3R

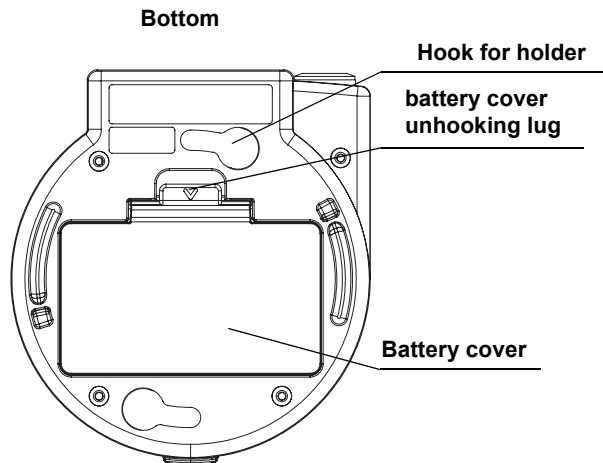
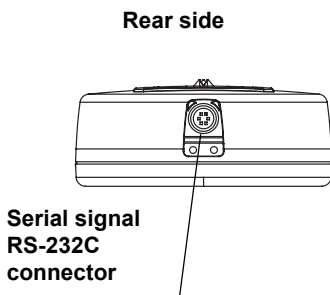
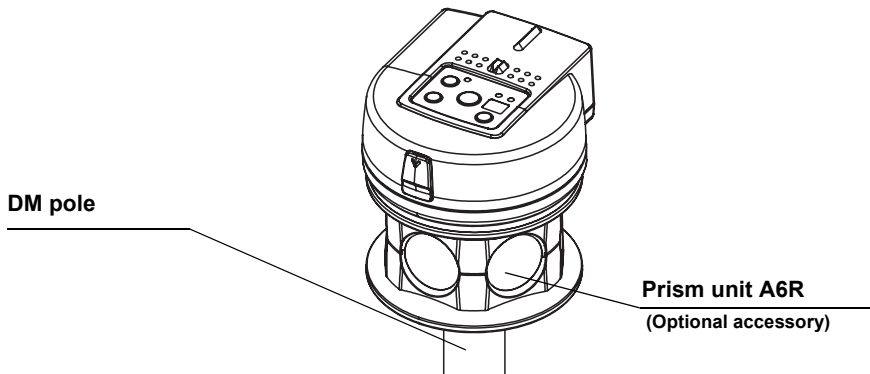
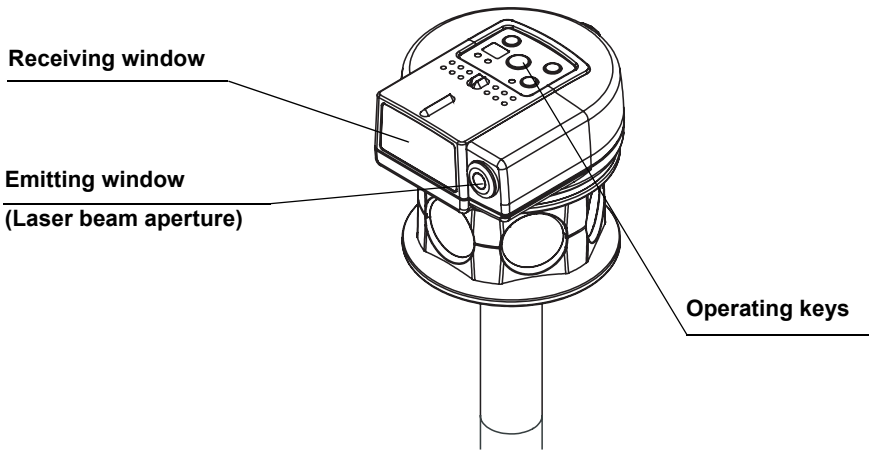

Panel

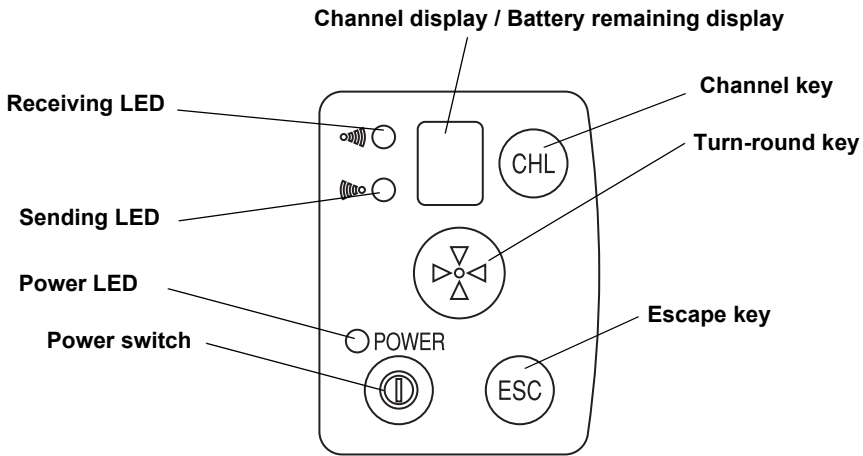

Key	Function
Power switch	ON/OFF of power of the RC-3R.
Turn-round key	Total station will be in turn-round motion.
Escape key	Cancels the emitting laser for turn-round motion. The total station will stop the turn-round operation after continuing the motion for a while.
Channel key	Sets up channels for optical communication.

LEDs

LED	Status	Contents
Power LED	On solid	The power of RC-3R is ON.
	Flash	The battery remaining of RC-3 is low. The battery should be recharged or replaced with a fully charged battery.
	Off	The power is OFF
Receiving LED	On solid	RC-3R is in the middle of data reception.
Sending LED	On solid	RC-3R is in the middle of data transmission.
	Flash	RC-3R is in the middle of turn-round command transmission.

Remote Controller Handle Unit RC-3H

GTS-900A, GPT-9000A series total station requires RC-3H to enable turn-round motions and optical communications with RC-3H.

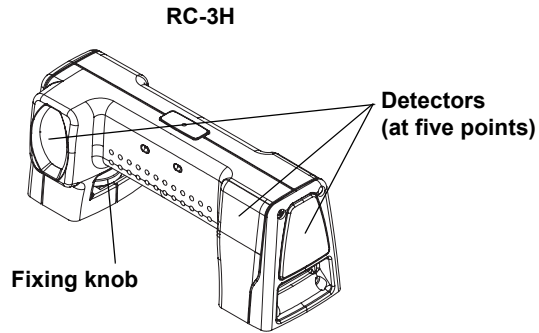

GTS-900A, GPT-9000A series carrying case is large enough to house the total station fitted with RC-3H.

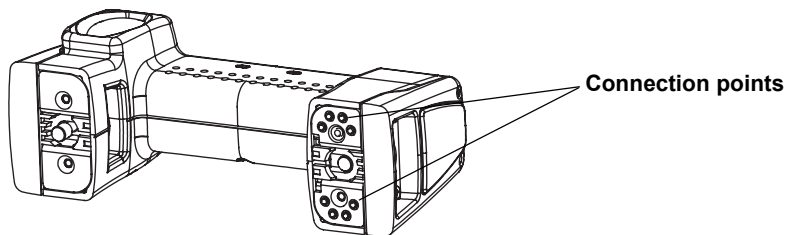

Do not damage or shock connection points. It may cause malfunction.

Installing RC-3R onto the prism unit A6R

- 1 Match the receiving window with the front mark and insert the mounting hooks on the Prism Unit A6R into the mounting holes of the RC-3R.

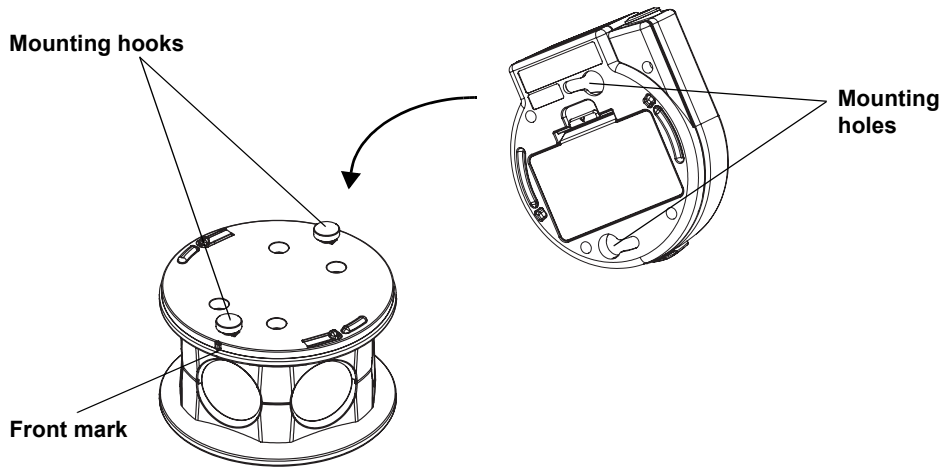

- 2 Turn the RC-3R towards the front mark (until you hear a click).

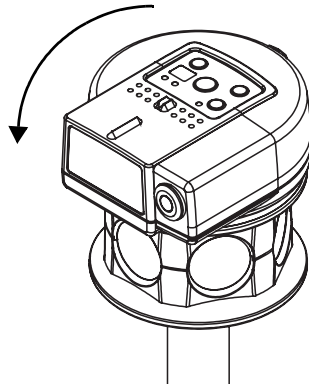

Communication between the RC-3 and a data collector

- For communicating between the data collector and the RC-3R by means of Bluetooth.
- For communicating between the data collector and the RC-3R by means of an RS-232C connector, connect the cable to the RC-3's RS-232C connector.

Mounting remote controller handle unit RC-3H onto the total station

Optical communications between total station and RC-3R, become possible by installing remote controller handle unit RC-3H onto the total station.

- 1 Dismount the handle from total station.

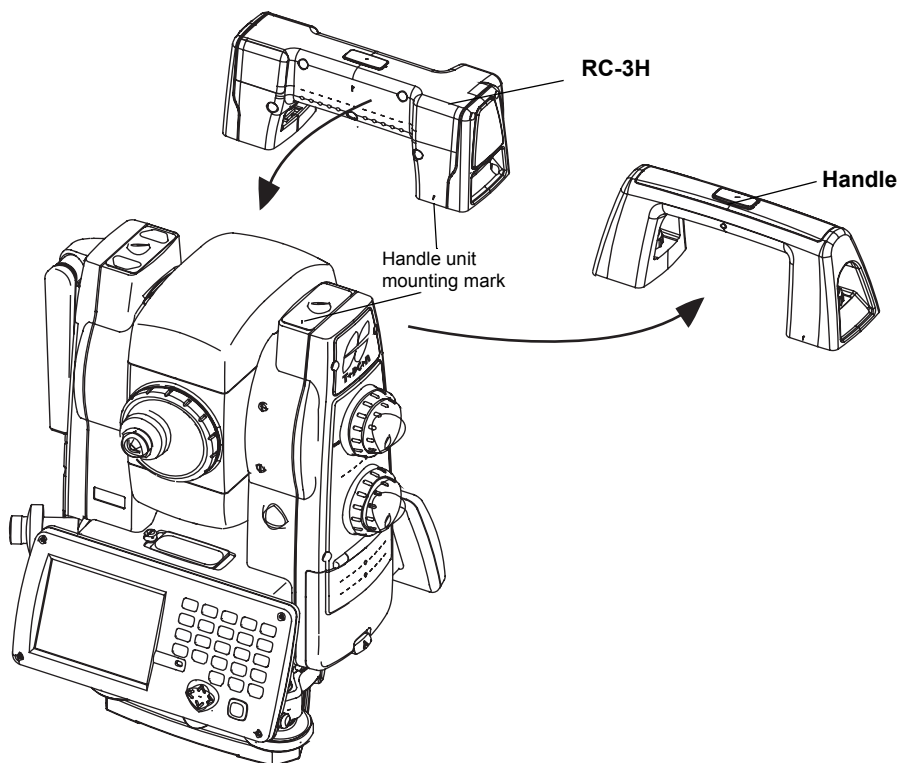

- 2 Match the handle unit mounting marks for the RC-3H and total station.
- 3 Make sure that the fixing knob is tightly fastened.

Note	• Ensure that the power switch of total station is off when mounting RC-3H.
-------------	---

Basic Operation

Power switch ON

Press the power switch.
Power LED will light.

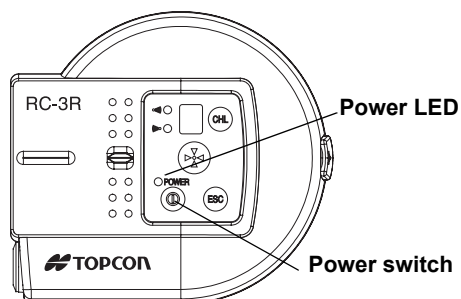

Battery Remaining Display

Push [ESC] key and the battery remaining capacity will be displayed for approximately 5 seconds.

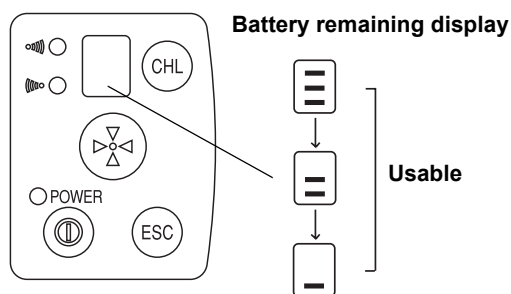

Battery Warning Display for RC-3R

When the battery of the RC-3R is low, the power LED will flash with beep sound.
(Audio sound: Two pitches, frequent beep synchronized with power LED)
Confirm the battery remaining when turning on the instrument.
When the LED is displayed and the beep sounds, replace or recharge the battery.

Battery Warning for GTS-900A, GPT-9000A series

When the battery power of total station in optical communication with RC-3R is low, the beep will sound from the RC-3R.
(Audio sound: Three pitches, frequent beep)
When the beep sounds, replace or recharge the batteries of total station.

Auto Power Off

If no key operation is given or no communication is performed for more than 30 minutes, the power turns off automatically.

Error display

The RC-3R unit does not display errors.
Refer to the operation manual for the data collector and other software for details.

Setting for Optical communications with total station

The following settings is prerequisites for the optical communications to take place between the total station (or an application program) and RC-3R.

Setting Parameters in total station

- **When communicating by using [EXT.LINK] of the application software (AP-L1 communication mode).**
 - 1 Set Parameter for RC.
Operation:
Main menu - Program Modes (Prog) - (EXT.LINK) - (Setting) - (RC)
 - 2 Execute the External Link.
Operation:
Main menu - Program Modes (Prog) - (EXT.LINK) - (Execute)

- **When communicating without using [EXT.LINK] (GTS communication mode).**
 - 1 Set the parameters in the Parameters Setting Mode. (Refer to Table of item to be set shown as follows.)
Operation:
Main menu - Parameters Setting Modes (SETUP) - (communication) - (RC)
 - 2 Execute the Standard Measurement Mode.
Main menu-Standard Measurement Mode (Meas)

Setting Parameters in RC-3R

Set the parameters in Setting Mode.
Refer to Table of item to be set in Setting Mode.

Setting Parameters of Communication port in Data Collector

Connect a data collector to be used to the serial RS-232C connector of the RC-3R, and set the items as follows.

B.Rate	9600
Data.L	8
Parity	none
Stop Bit	1

Table of item to be set

Following parameters surrounded that you must set for RC-3R and total station.

- **Setting Parameters in total station**

Operation			Item	Setting	
				By using "EXT.LINK" (AP-L1 communication mode)	Without using "EXT.LINK" (GTS communication mode)
Main menu Prog EXT.LINK	Setting	PARAMETER(RC)	RC	Select	_____
			REC TYPE	Select	
			Terminate	Select	
Main menu Setup Com.		RC	Channel	Select Matches the communication channel to RC-3R.	
			V.Search	Select	Select
			RC	Select	Select
			CR, LF	_____	Select

The content of each set item of "EXT.LINK" is the following.

Moreover, please refer to the total station's manual for Parameters.

Channel	1/2/3/4/5/6	Refer to "Setting Mode".
Terminate	ETX / ETX+CR / ETX+CR+LF	Select the option OFF or ON for carriage return and line feed when collecting measurement data with a data collector.
REC TYPE	REC-A /REC-B	Select the option to record the data. REC-A: The measurement is started and new data is output. REC-B: The data memorized in total station is output.

- **Setting Parameters in RC-3R**

Communication channel	Select
RS-232C Baud rate	Select

Light emitting angle

Laser beams are emitted from the emitting window of the RC-3R.
The angle of emitting laser beams is as follows.

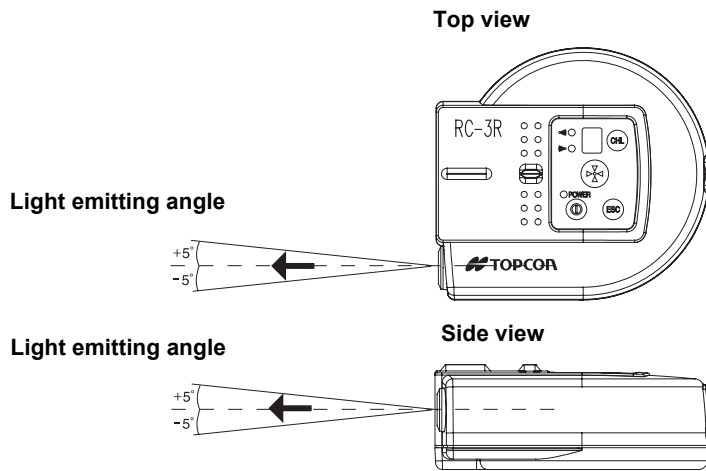

At greater distances, the laser light at the edge of the beam field (angle) will be weaker.

Important	<ul style="list-style-type: none"> RC-3R should be kept aiming so that the total station always stays within the above range of laser beam emission until the turn-round motions or optical communications are completed. If the aiming is out of above range while RC-3R is in turn-round motions or optical communications, the turn-round or optical communications could not be completed.
------------------	---

Light detecting range

The detecting angles of RC-3R and RC-3H (Total station) are shown below:
 Total station can only be turned round with the turn-round key under the condition that RC-3R remains confined within the range as shown below where RC-3H can detect light.
 RC-3R should be aimed in a way to always capture the total station within this range during receiving data from the total station.

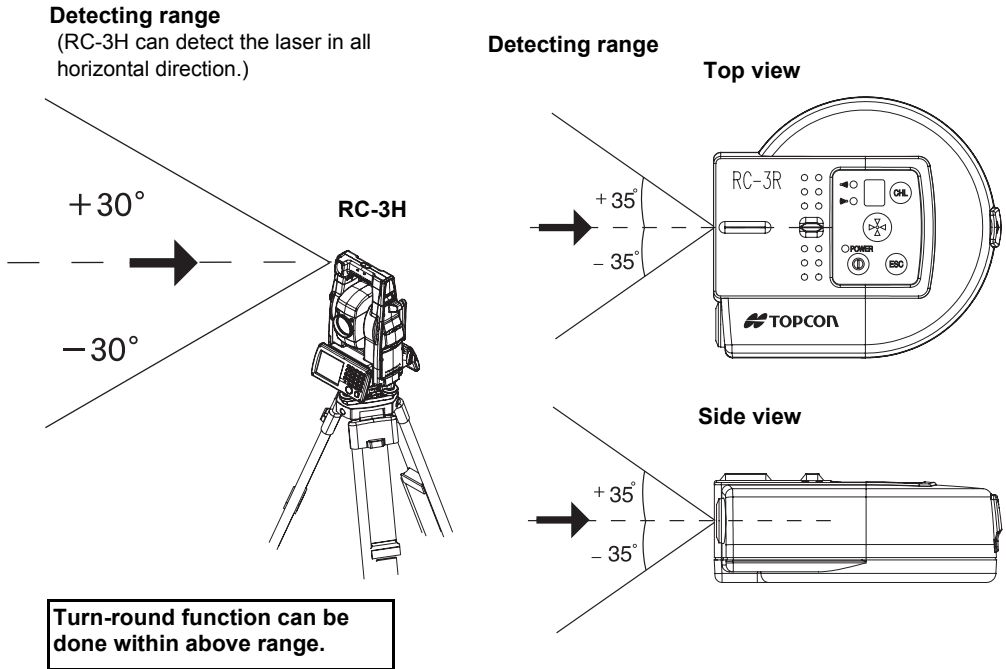

Important	<ul style="list-style-type: none"> The RC-3R must be aimed so as to capture the total station within above range during communicating.
------------------	---

Turn-round function

Important	<ul style="list-style-type: none"> • RC-3R should be kept aiming so that the total station always stays within the above range of laser beam emission until the turn-round motions is completed. If the aiming is out of above range while RC-3R is in turn-round motions, the turn-round could not be completed. • At greater distances, the laser light at the edge of the emitting range (angle) will be weaker; therefore, the RC-3R must be aimed correctly.
------------------	---

The turn-round key on RC-3R is used to have the total station search or automatically track RC-3R (prism).

In the auto tracking mode, RC-3R and the total station are ready for optical communications.

Turn-round function is useful for auto-tracking when you start working or when the auto-tracking is interrupted by any reason.

For increasing efficiency, keep the auto-tracking status when you move to another measurement point.

Note	<ul style="list-style-type: none"> • The settings and conditions of communication are prerequisites for the optical communications to take place between the total station and RC-3R.
-------------	--

- 1 Turn on the total station and execute the [External Link].
- 2 Aim the RC-3R light emitter at the total station.



- 3 Turn On the RC-3R by pressing the power switch.
- 4 Press the [turn-round] key on RC-3R.
Total station starts searching and ends in the tracking mode where it is communicable with this system.

Note	<ul style="list-style-type: none"> • Total station must be kept apart from reflecting planes such as glass and white walls. Reflected light may prevent it from correct prism searching and from auto tracking. In this case, change the power mode of RC-3R to the low power mode to decrease the output of laser beam. To change the power mode, see “Low Power mode of Laser Beam” on page 17. • Ensure that RC-3R remains as motionless as possible when the total station is in turn-round motions. Total station otherwise may not be able to search prism correctly, requiring extra time for the task. • The RC-3R must be aimed so as to capture the total station within a range of $\pm 35^\circ$ in the vertical and horizontal direction during communicating. (Refer to “Light detecting range” section.)
-------------	---

Stopping turn-around operations

Press the [ESC] key to terminate turn-around operation. After the key is pressed, turn-around operation will continue for a short time before the Total Station comes to a stop.

Low Power mode of Laser Beam

When the Total Station performs a turn-around function at a distance of approximately 10 m from the RC-3R, strong reflections of the pulsed laser diode (PLD) emission can prevent the Total Station from searching the prism correctly. In this case, switch the laser to low-power mode to reduce the intensity of such reflections.

In low-power mode, the range of the turn-round function is shorter than in normal-power mode.

To change the low-power mode

Turn the power ON while holding down the [ESC] key.

A buzzer will sound indicating that the RC-3R is in low-power mode.

To return to normal-power mode, turn the power OFF, wait several seconds, and then turn the power ON again.

Reference : Turn-round motions:

When the turn-around key on the RC-3R is pressed, the pulsed laser diode (PLD) in the emitter produces a laser beam with a $\pm 5^\circ$ cone pattern (Refer to "Light emitting angle" on page 14.)

The RC-3H component of the Total Station has photo detectors on all four sides (front, rear, right and left), allowing laser beams to be detected in any orientation. This detection ability extends to approximately $\pm 30^\circ$ in the vertical direction (refer to "Light detecting range" on page 15.)

Upon detecting laser emissions, the Total Station aligns toward the RC-3R.

After horizontal alignment, the telescope is scanned vertically in order to target the prism and initiate auto tracking.

Under certain conditions, the time required for communications can increase to the point that turn-around operations require a long time to complete, and under certain circumstances such operations might not even be completed properly. The following conditions can adversely affect operation:

- 1) When units are used for communication over long distances or under poor atmospheric and weather conditions (e.g., in strong direct sunlight; heat refraction such as occurs near road surfaces and building surfaces on hot days; rain; fog, etc.)
- 2) When the aim of the RC-3R is set incorrectly (refer to "Light emitting angle" on page 14.)
- 3) When the installation position of the prism and RC-3R are separated (refer to "Setting Mode" on page 18.)
- 4) When communication channel settings, or other settings, of the total station and RC-3R are not matched or are set incorrectly (refer to "Table of item to be set" on page 13 and "Setting Mode" on page 18.)
- 5) When the total station is located in front of or to the side of glass or some other reflective surface.
- 6) When, during turn-around operations, a person, car, or other object obstructs the light path between the total station and the RC-3R.
- 7) When the units are used over long distances, the RC-3R is set to low-power mode ("Low Power mode of Laser Beam" on page 17.)
- 8) When the dip switch settings on the RC-3R are set incorrectly (refer to "Setting Mode" on page 18.)
- 9) When the battery status display on the total station is flashing (low battery power)

Setting Mode

In this mode, following items can be set.

Setting Items

Items	Selecting item	Description
Optical communication channel	1 to 6	Sets a channel to be used for communications. The same communication channel must be assigned to both RC-3R and the total station. Prevents interference of communication when several systems consisting of a total station and a RC-3 are used at one site.
Communication baud rate	9600/4800	Select communication speed.

How to Set

Remote control channel

- 1** With the power ON, push the channel change key on the panel once.
Current channel will be displayed (Default setting: 1)
- 2** While the channel is displayed (approx. 5 seconds), push the key once again.
It will switch to the next channel.
- 3** Repeat step 2 until the channel you wish to set is displayed.
(The optical communication channel setting cannot be changed during turn-round.)

Communication Baud Rate

Setting can be done with the dip-switch on the battery section.

- 1 Remove battery cover and batteries.
- 2 Set by pressing the dip-switch with a pin.

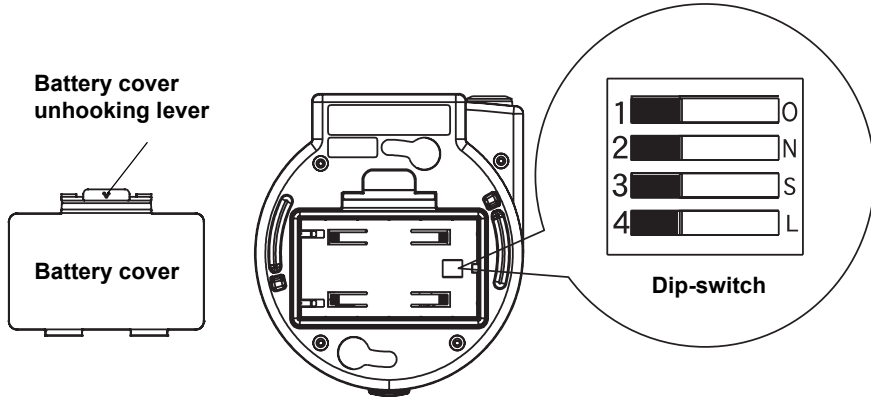

- 1 — Serial signal RS-232C baud rate setting
- 2 — Unused (fixed to OFF)
- 3 — Unused (fixed to OFF)
- 4 — Unused (fixed to OFF)

Dip-switch	Setting	Contents
1	OFF	9600
	ON	4800
2	Unused (fixed to OFF)	----
3	Unused (fixed to OFF)	----
4	Unused (fixed to OFF)	----

Note	<ul style="list-style-type: none"> • Dip-switch No.2-4 must be fixed to OFF position. The RC-3R does not work correctly when the switch No.2-4 are set to ON position.
-------------	---

Power Source and Charging

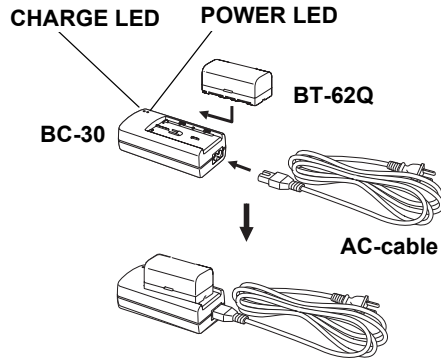

- 1 Connect the AC-Cable to the charger.
- 2 Plug the AC-Plug into the outlet. (The POWER LED will light.)
- 3 Attach the battery in the charger. Charging will start. (The CHARGE LED will light.)
Charging will take approximately 4 hours. (The CHARGE LED will go out.)
If battery power is at a very low level when beginning charging, such as after the instrument has been in storage over an extended period of time in a discharge state, a full charge may not be possible with a single charging. In such a case, recharge a second time.
- 4 After charging, remove the battery from the charger.
Remove the charger from the outlet.

The POWER LED

Red ON : Power is on.

The CHARGE LED will indicate charging status;

On Solid : Wait for charging.
Red ON : Charging.
On Solid : Charging completed.
Red Flashing: Charging error.

CHARGE LED will flash when the battery life is over or the battery is broken down. Replace the battery to new one.

- When CHARGE LED flashes, reinstall the battery or re-plug the outlet of the charger. If CHARGE LED still continues to flash, there may be breakdown of the battery or the charger. Stop charging immediately, unplug the charger and contact the distributor.
- Do not charge or discharge continuously, otherwise the battery and the charger may be deteriorated.
If charging is necessary, use the charger after stopping charge for approximately 30 minutes.
- Do not charge the battery or discharge the battery in right after the battery is charged, it causes deterioration of the battery in rare cases.
- The charger may develop heat while charging, there is no problem of it.
- Recharging should take place in a room with an ambient temperature range of 10°C to 40°C (50°F to 104°F).
- Exceeding the specified charging time may shorten the life of the battery and should be avoided if possible.
- The battery source will discharge when stored and should be checked before using with instrument.
- If the instrument is not used over an extended period of time, store in a place at 30°C or below in a 50% charged state.
Over discharge will lower performance and a full charge may become impossible. Please charge once every few months.

Special Accessories



Data Collector

Suitable for systemization of measuring instrument. Measuring data will be automatically stored and transferred to a computer system, making measuring operations more efficient and saving time and effort in such operation.

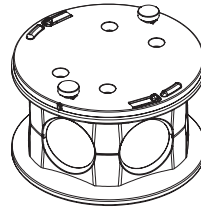

Prism unit-A6R/A6S

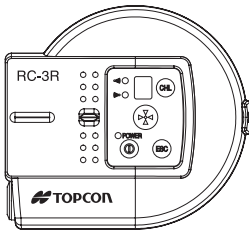

RC-3R

Precaution

- Always clean the instrument after use.
- Remove the dust using a brush, then wipe off with a soft cloth.
For cleaning the lens surface of the receiving window, use a cleaning brush, then use a clean lintless cotton cloth. Moisten it with alcohol (or mixture with ether) to wipe gently in a rotational motion from the center out.
- To remove the dust on the surface of emitting window or the parts made by plastic, never use thinner or benzine. Use a clean cloth moistened with neutral detergent.
- Always make sure the instrument is completely dry before storing. Dry any moisture with a soft, clean cloth.

Specifications

Operating temperature	:	-20°C to +50°C
Storing temperature	:	-30°C to +60°C
Protection against water and dust	:	RC-3R: IP65 RC-3H: IP54 (Based on the standard IEC60529)
Operating distance * 1)	:	5m~400 m (16ft ~1310 ft) (When using with the prism unit A6R/A6S)
	* 1)	The operating distance may be shorter than normal in such the condition is not good by the heat shimmer or strong direct sun shine to the detector.
Turn-round operating time	:	Approximately 10 seconds *2, 3)
Optical communicating time	:	Approximately 3 to 4 seconds *2, 4)
	* 2)	Sight haze with visibility about 20km (12.5 miles) moderate sunlight with light shimmer.
	* 3)	Under normal weather conditions, with the telescope turned 90° relative to the prism, and turn-around performed with the prism roughly aligned vertical. (refer to "Reference : Turn-round motions:" on page 17.)
	* 4)	Standard times for data display and data recording. Times may vary depending on software version.
Number of optical communication channels	:	6

Remote Controller Handle Unit RC-3H

Power source	:	DC 7.4V from total station
Detective range	:	Horizontal : 360° Vertical : ±30°
Weight	:	0.3 kg
Dimensions	:	58(D) × 166(W) × 71(H) mm

Remote Controller RC-3R

Weight	:	0.3 kg
Dimensions	:	122 (D) × 110 (W) × 46 (H) mm
Bluetooth™ Unit		
Bluetooth™ Standard	:	Bluetooth™ Specification v1.2
Bluetooth™ profiles	:	Generic Access Profile Service Discovery Application Profile Serial Port Profile
BD Address	:	IEEE std802 48bit LAN MAC Address
Bluetooth™ Transmitting	:	Output Class2
Bluetooth™ Communication distance	:	About 5m (The range will be different by a condition)

[Emitting Laser]

- Angle of Laser : Each direction $\pm 5^\circ$
 At greater distances, the laser light at the edge of the emitting range (angle) will be weaker by laser emitting characteristic.
 100m (328ft): Approximately $\pm 5^\circ$
 400m (1310ft): Approximately $\pm 3^\circ$
- Laser class : Class 1/ Class I

[Detecting Laser]

- Detecting range : Horizontal $\pm 35^\circ$
 Vertical $\pm 35^\circ$

[Interface]

- Connector with 6 pins : RS-232C
 Baudrate: 9600/4800
 Bit length: 8 bits
 Parity bit: None
 Stop bit: 1 bit

Rechargeable Battery BT-62Q

- Output voltage : DC7.4V
- Capacity : 2200mAh
- Maximum operating time : 20hours *1)
- *1) Normal use Under normal temperature at $+20^\circ\text{C}$, Measuring two points (Including communicating and recording data) every 1 minute and using turn-around function once every 10 minutes.
 In low temperature, operating time will decrease rapidly due to the characteristic of battery.



FC Tested to comply
With FCC Standards
FOR HOME OR OFFICE USE

Regulatory Information

U.S.A.

This equipment has been tested and found to comply with the limits for a Class B digital device, pursuant to Part 15 of the FCC Rules. These limits are designed to provide reasonable protection against harmful interference when the equipment is used in a commercial or residential environment. This equipment generates, uses and can radiate radio frequency energy and, if not used in accordance with the instruction manual, may cause harmful interference to radio communications.

Operation of this equipment is subject to the following two conditions:

- (1) The device may not cause harmful interference.
- (2) This device must accept any interference received, including interference that may cause undesired operation.



Bluetooth™ and the Bluetooth™ logos are trademarks owned by Bluetooth™ SIG, Inc., USA and licensed to Topcon Corporation.

TOPCON CORPORATION

75-1 Hasunuma-cho, Itabashi-ku, Tokyo 174-8580, Japan
Phone: 3-3558-2520 Fax: 3-3960-4214 www.topcon.co.jp

©2006 TOPCON CORPORATION
ALL RIGHTS RESERVED