

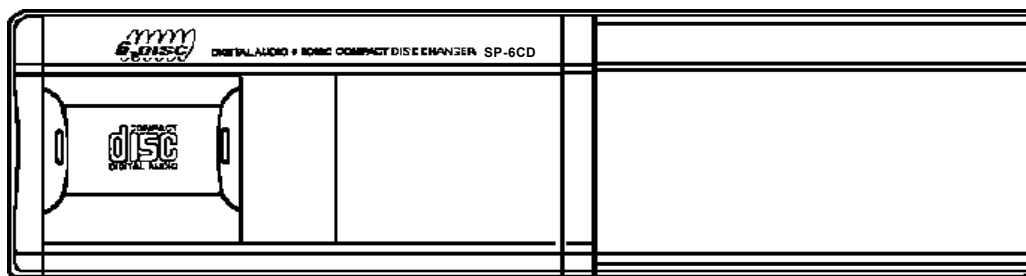

## INSTALLATION MANUAL



### 6 - DISC CD CHANGER SYSTEM



# MODEL SP-6CD

# PACKING LIST

## MAIN UNIT

Changer

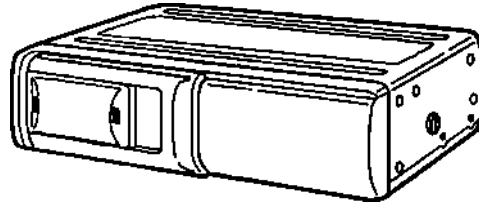

## INSTALLATION PARTS

Bracket (L)

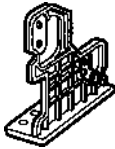

1 pc.

Bracket (R)

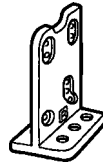

1 pc.

Self-Tapping Screw  
(M5 x 12)



4 pcs.

Hexagonal Bolt  
with Washer  
M5 x 8



4 pcs.

5 Meter DIN cable  
(8 pin)

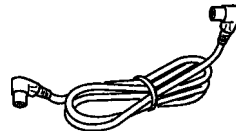

1 pc.

Seals

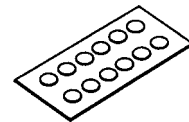

1 pc.

## OTHER ACCESSORY

CD Magazine

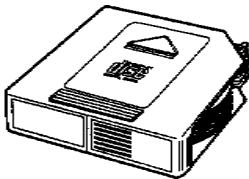

1 pc.

Index seal sheet

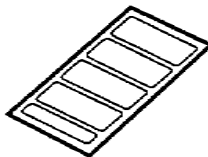

1 pc.

Installation  
Manual

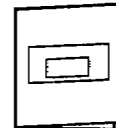

1 pc.

Owner's  
guide

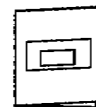

1 pc.

# BEFORE INSTALLING THE UNIT

## Transport lock screws

The mechanism in the CD changer is "locked" into place during shipment by the transport screws. Be sure to remove the screws prior to installation.

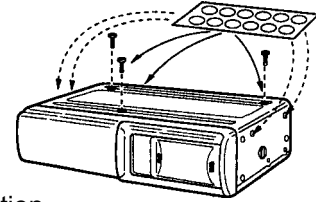

### Caution

After removing the transport lock screws, place the supplied seals over the screw holes. These seals are used to keep dust out of the unit, which could cause a malfunction.

## Installation and Wiring Precautions

- 1 To prevent a short-circuit,  
Be sure to turn off the ignition and remove the negative (-) battery cable, prior to installation.  
Connect power wires last.

### Note

If the changer is to be installed in a car that is equipped with an on-board drive or navigation computer, do not disconnect the battery cable. If the cable is disconnected, the computer memory may be lost. Under these conditions, use extra caution during installation, not to cause a short circuit.

- 2 Do not install the unit in the following locations.  
Locations exposed to direct sunlight.  
Where hot air is discharged from the car heater.  
When proper installation is not possible and where a great deal of vibration is generated.



- 3 Be sure to use the supplied brackets and screws.  
Be careful not to snag any wires when tightening screws and installing the ground wire.  
When installing the unit, do not use any screws that are part of the brake or steering system.

- 4 This unit cannot be installed in any way except that which is authorized (on its side, on its end, at a 45° angle or suspended).

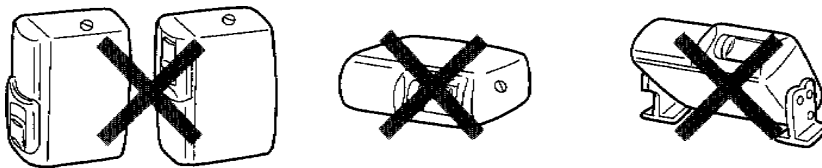

# SETTING THE ANTI-VIBRATION SPRINGS

This unit can be installed horizontally (suspended), vertically, and at a 45° angle. Once the installation position has been decided, it's necessary to set the position of the built-in anti-vibration springs inside the unit. Please do this before performing the procedure. Vibration may cause the disc to skip if the unit is used before properly setting the anti-vibration springs.

At the time of shipping, the built-in anti-vibration springs is set for horizontal installation "H".

There are built-in anti-vibration springs on both the left and right sides.

Set the anti-vibration springs position with a screwdriver before attaching the brackets.

## For use when unit is installed horizontally or suspended:

Confirm that the built-in anti-vibration springs is set to position "H".

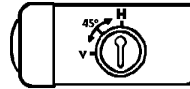

## For use when unit is installed vertically:

The built-in anti-vibration springs should be set to position "V".

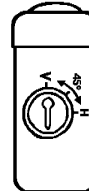

## For use when unit is installed at a 45° angle:

The built-in anti-vibration springs should be set to position "45°".

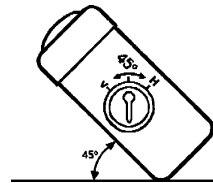

# PROCEDURE FOR HORIZONTAL INSTALLATION

- 1** Confirm that the built-in anti-vibration springs on both the left and right sides are set to the horizontal installation position "H".

Attach bracket (L) and bracket (R) using the hexagonal bolts (M5 x 8).

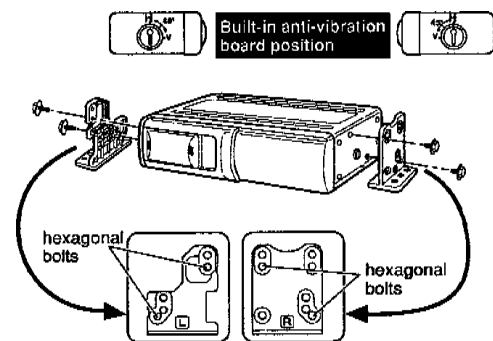

- 2** Determine the mounting location and drill four mounting holes.

Never mount the unit near the fuel tank.

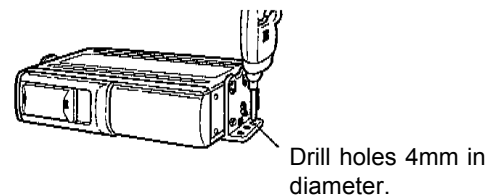

- 3** Secure the unit in place using four self-tapping screws (M5 x 12).

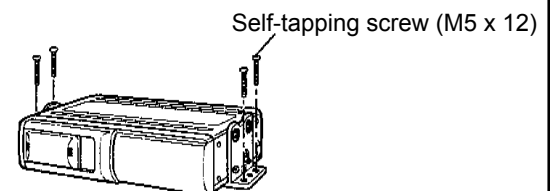

# PROCEDURE FOR VERTICAL INSTALLATION

- 1** Confirm that the built-in anti-vibration springs on both the left and right sides are set to the vertical installation position "V".  
Attach bracket (L) and bracket (R) using the hexagonal bolts (M5 x 8).

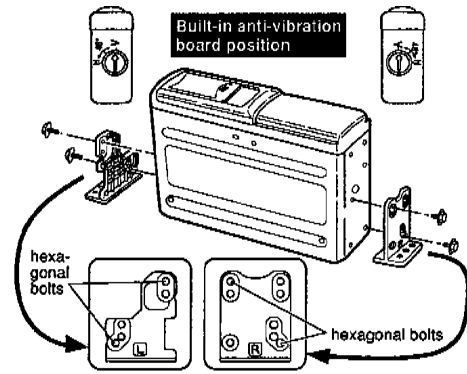

- 2** Determine the mounting location and drill four mounting holes.

Never mount the unit near the fuel tank.

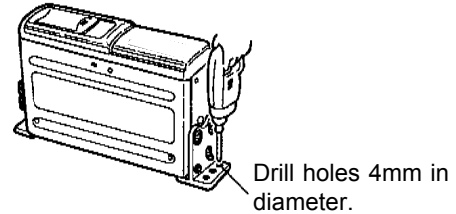

- 3** Secure the unit in place, using four self-tapping screws (M5 x 12).

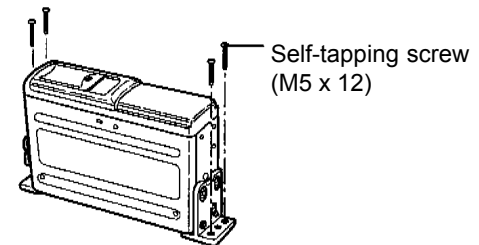

# PROCEDURE FOR 45° ANGLE INSTALLATION

- 1** Confirm that the built-in anti-vibration springs on both the left and right sides are set to the 45° installation position "45°".  
Attach bracket (L) and bracket (R) using the hexagonal bolts (M5 x 8).

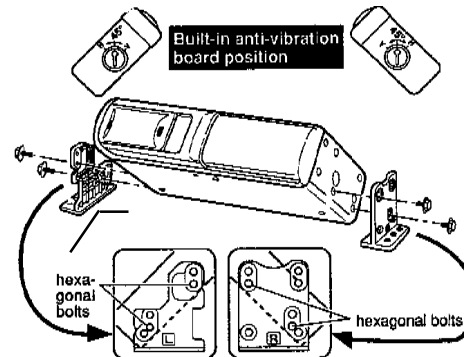

- 2** Determine the mounting location and drill four mounting holes.

Never mount the unit near the fuel tank.

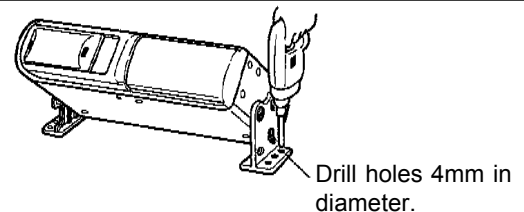

- 3** Secure the unit in place using four self-tapping screws (M5 x 12).

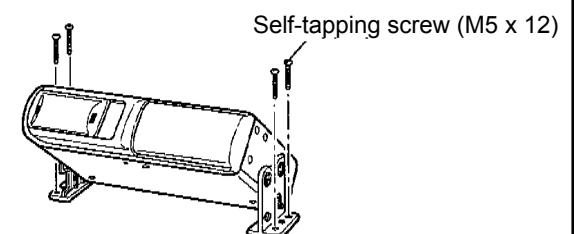

# PROCEDURE FOR MOUNTING UNDER REAR DECK

1

Confirm that the built-in anti-vibration springs on both the left and right sides are set to the horizontal installation position "H".  
Attach bracket (L) and bracket (R) using the hexagonal bolts (M5 x 8).

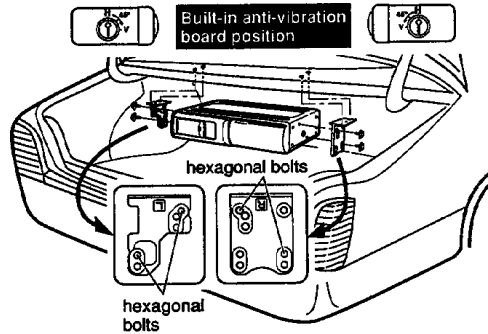

2

Determine the mounting location and drill four mounting holes.

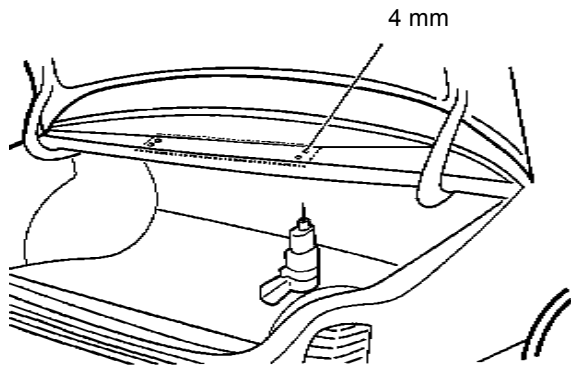

3

Attach the CD changer using four self-tapping screws (M5 x 12).

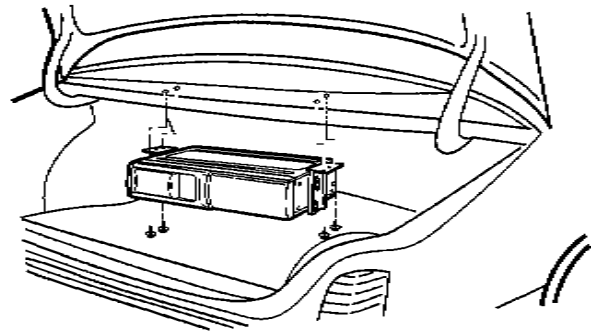

# VEHICLE WIRING

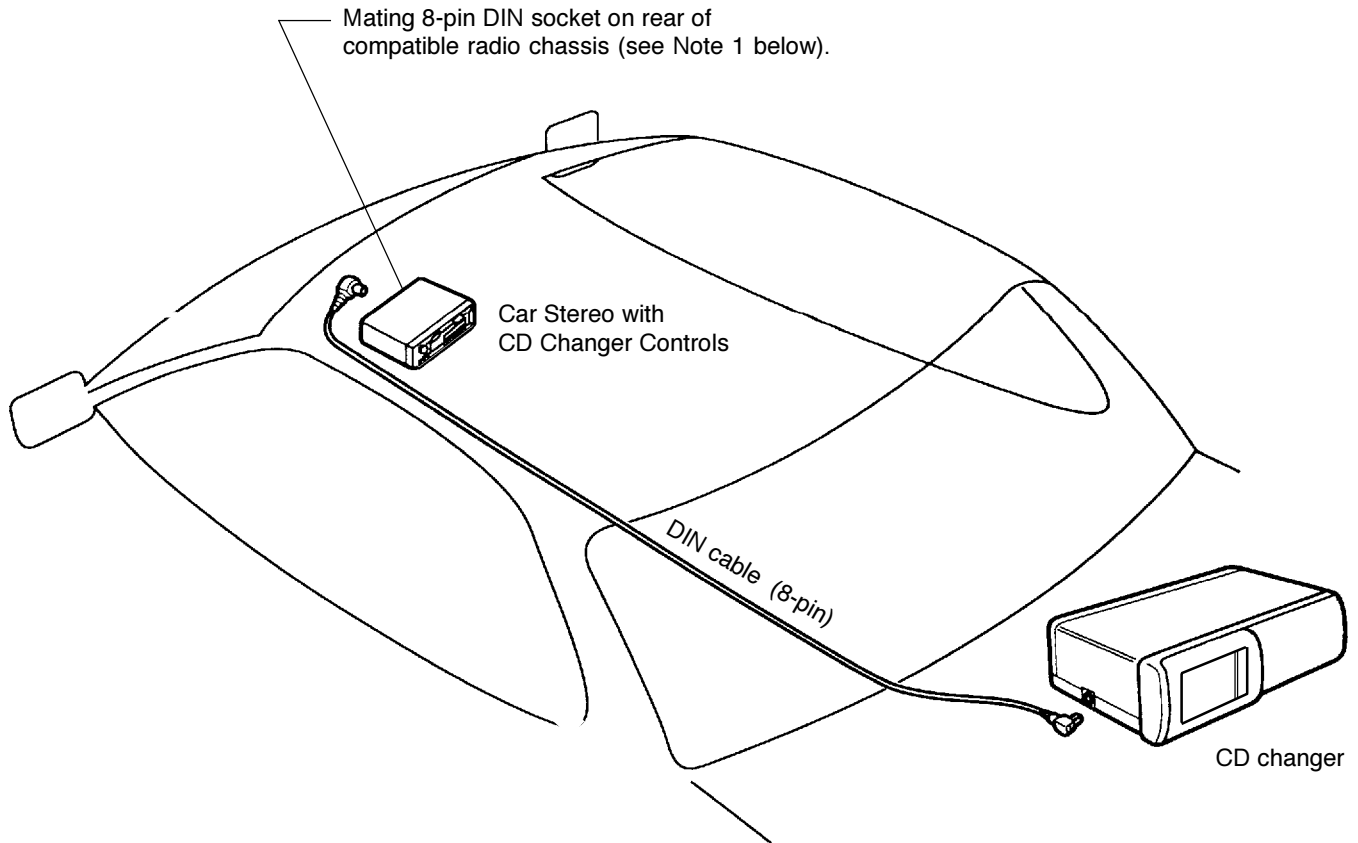

- NOTE:** 1. Check with your Audiovox car audio dealer to be sure your stereo is directly compatible with this CD changer.
2. Wiring instructions for use with FM Modulator/Commander Systems are included with the CDC-MC1, CDC-MCR2, P-MC3 and P-MCR4 accessories.