

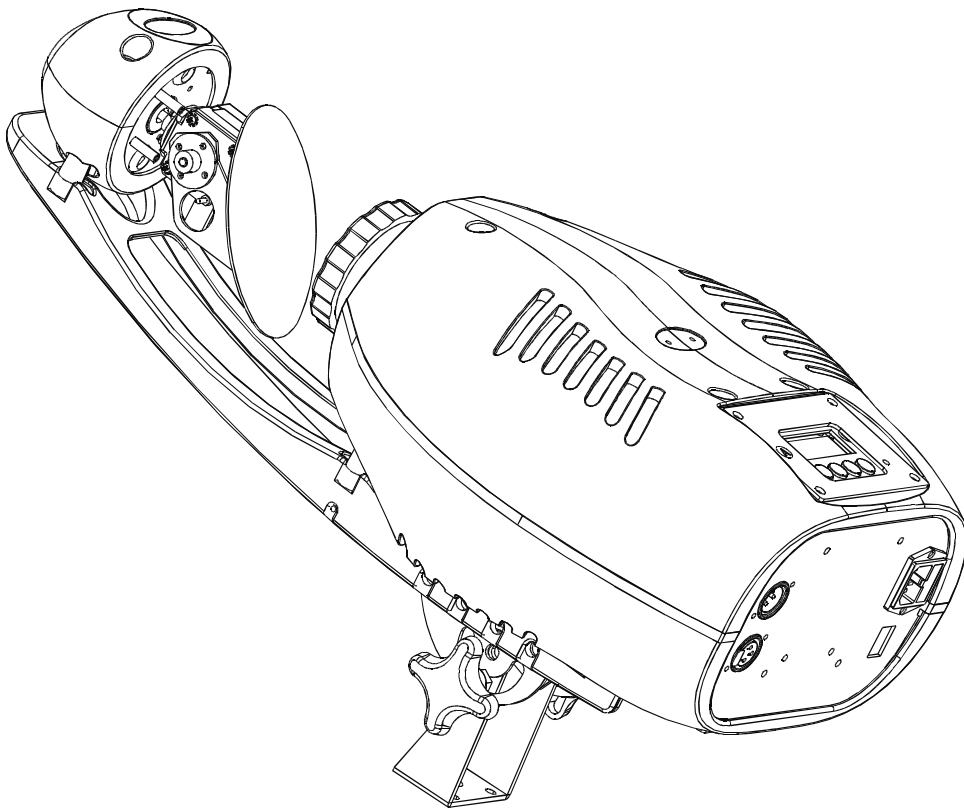

PROFESSIONAL SCANNER USER MANUAL



WALLY SC 20

KEEP THIS MANUAL FOR FUTURE NEEDS



Thank you for your patronage. We are confident that our excellent products and service can satisfy you. For your own safety, please read this user manual carefully before installing the device.

In order to install, operate, and maintain the lighting safely and correctly. We suggest that the installation and operation should be done by the verified technician and follow the instruction strictly.

	CAUTION! Keep this device away from rain and moisture !
	CAUTION! Unplug mains lead before opening the housing.

INTRODUCTION:

Thank you for having chosen this professional scanner.
You will see you have acquired a powerful and versatile device.

Unpack the device. Inside the box you should find:

1. One XLR connection cable
2. One power cable
3. One safety rope
4. Manual

Features

- LED type: SST-50
- Extremely Long Life: 100,000 hr and lower power consumption
- Control channel: 9 channels
- Pan: 180° movement, Tilt: 36° movement.
- Strobe: 0~13 flashes per second, or random strobe.
- Colours: 8 colours plus white, with rainbow effect.
- Gobos: 7 rotating gobos plus open, with different speed gobo shaking.
- Linear dimmer in precise speed from 0% ~ 100%
- Display: 4-digit display.
- Display: Can be changed 180° reverse to fit for different installation position.
- Fan automatically adjust speed according to the LED temperature
- Auto programs: 8 pre-built programs can be selected
- Software-upload by optional accessory via DMX line

OVERVIEW

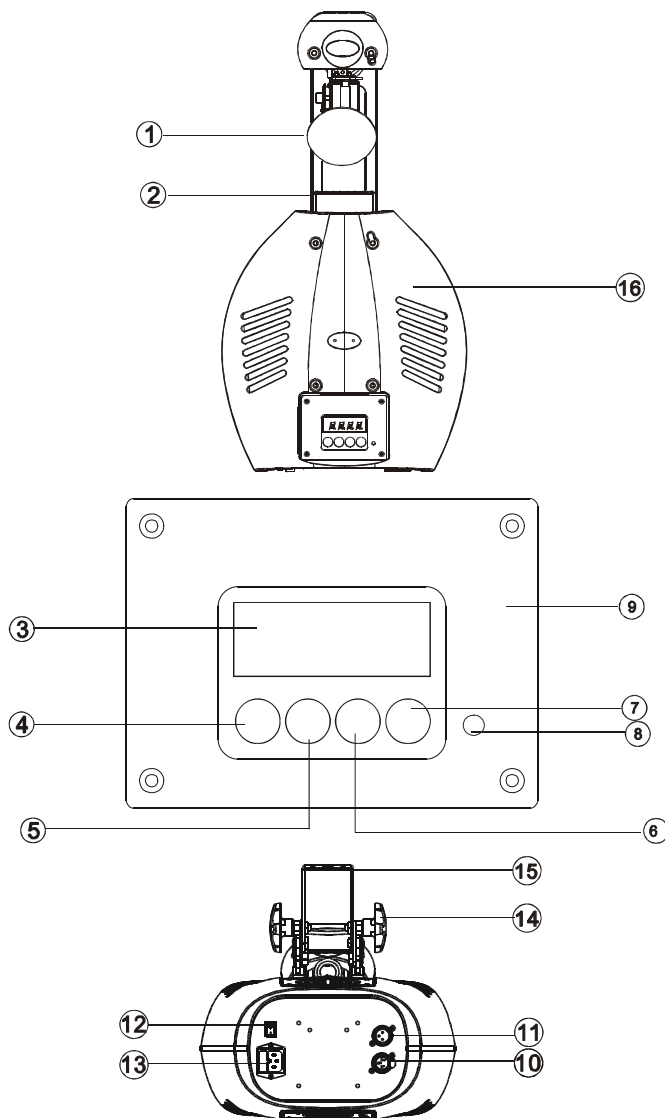

- 1) Viewfinder
- 2) Lens
- 3) Display
- 4) Mode/Esc-button
- 5) Up-button
- 6) Down-button
- 7) Enter-button
- 8) Microphone
- 9) Control board
- 10) 3-Pin DMX out
- 11) 3-Pin MDX in
- 12) Power switch
- 13) Power input / Fuse
- 14) Cross screw
- 15) Join stand
- 16) Housing

SAFETY INSTRUCTIONS

	<p>CAUTION! Be careful with your operations. With a dangerous voltage you can suffer a dangerous electric shock when touching wires!</p>
---	---

This device has left the factory in perfect condition. In order to maintain this condition and to ensure a safe operation, it is absolutely necessary for the user to follow the safety instructions and warning notes written in this user manual.

Important:
 **Damages caused by the disregard of this user manual are not subject to warranty. The dealer will not accept liability for any resulting defects or problems.**

If the device has been exposed to temperature changes due to environmental changes, do not switch it on immediately. The arising condensation could damage the device. Leave the device switched off until it has reached room temperature.

This device falls under protection-class I. Therefore it is essential that the device be earthed.

The electric connection must carry out by qualified person.

Make sure that the available voltage is not higher than stated at the end of this manual.



Make sure the power cord is never crimped or damaged by sharp edges. If this would be the case, replacement of the cable must be done by an authorized dealer.

Always disconnect from the mains, when the device is not in use or before cleaning it. Only handle the power cord by the plug. Never pull out the plug by tugging the power cord.

During initial start-up some smoke or smell may arise. This is a normal process and does not necessarily mean that the device is defective, it should decrease gradually.

Please don't project the beam onto combustible substances.

If the external flexible cable or cord of this luminaire is damaged, it shall be exclusively replaced by the manufacturer or his service agent or a similar qualified person in order to avoid a hazard.

	CAUTION! Never touch the device during operation! The housing may heat up
	CAUTION! Never look directly into the light source, as sensitive persons may suffer an epileptic shock.

Please be aware that damages caused by manual modifications to the device are not subject to warranty. Keep away from children and non-professionals.

GENERAL GUIDELINES

This device is a lighting effect for professional use on stages, in discotheques, theatres, etc., the device was designed for indoor use only.

This fixture is only allowed to be operated with the max alternating current which stated in the technical specifications in the last page of this manual.

Lighting effects are not designed for permanent operation. Consistent operation breaks may ensure that the device will serve you for a long time without defects.

Do not shake the device. Avoid brute force when installing or operating the device.

While choosing the installation-spot, please make sure that the device is not exposed to extreme heat, moisture or dust. Please don't project the beam onto combustible substances. The minimum distance between light-output from the projector and the illuminated surface must be more than 0,5 meter.

If you use the quick lock cam in hanging up the fixture, please make sure the quick lock fasteners turned in the quick lock holes correctly.

Operate the device only after having familiarized with its functions. Do not permit operation by persons not qualified for operating the device. Most damages are the result of unprofessional operation.

Please use the original packaging if the device is to be transported.

For safety reasons, please be aware that all modifications on the device are forbidden.

If this device will be operated in any way different to the one described in this manual, the product may suffer damages and the guarantee becomes void. Furthermore, any other operation may lead to short-circuit, burns, electric shock, lamp explosion, crash, etc.

INSTALLATION INSTRUCTIONS

a) Mounting the device

	CAUTION! Please consider the GB7000.15/EN60598-2-17 and the other respective national norms during the installation. The installation must only be carried out by a qualified person.
---	---

The applicable temperature for the lighting is between -25°C to 45°C. Do not use the lighting under or above the temperature.

The installation of the effect has to be built and constructed in a way that it can hold 10 times the weight for 1 hour without any harming deformation.

The installation must always be secured with a secondary safety attachment, e.g. an appropriate safety rope.

Never stand directly below the device when mounting, removing or servicing the fixture.

The operator has to make sure the safety relating and machine technical installations are approved by an expert before taking the device into operation for the first time.

These installations have to be approved by a skilled person once a year.

Overhead mounting requires extensive experience, including amongst others calculating working load limits, installation material being used, and periodic safety inspection of all installation material and the device. If you lack these qualifications, do not attempt the installation yourself. Improper installation can result in bodily injury.

	CAUTION! Before taking into operation for the first time, the installation has to be approved by an expert.
---	---

Cautions:

The effect should be installed outside areas where persons may reach it, walk by or be seated.

	CAUTION! The electric connection must only be carried out by a qualified electrician.
---	---

Before mounting make sure that the installation area can hold a minimum point load of 10 times the device's weight.

Connect the fixture to the mains with the power plug.

Installation via the Omega holders

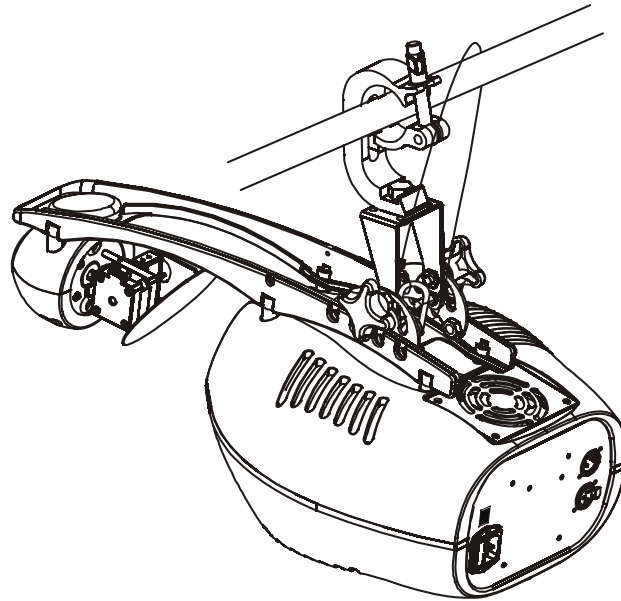

Screw one clamp each via a M12 screw and nut directly into the bracket of the scanner. Pull the safety-chain through the bracket of the base and over the trussing system or a safe fixation spot.

DMX-512 control connection

Connect the provided XLR cable to the female 3-pin XLR output of your controller and the other side to the male 3-pin XLR input of the moving head. You can chain multiple Moving head together through serial linking. The cable needed should be two core, screened cable with XLR input and output connectors. Please refer to the diagram below.

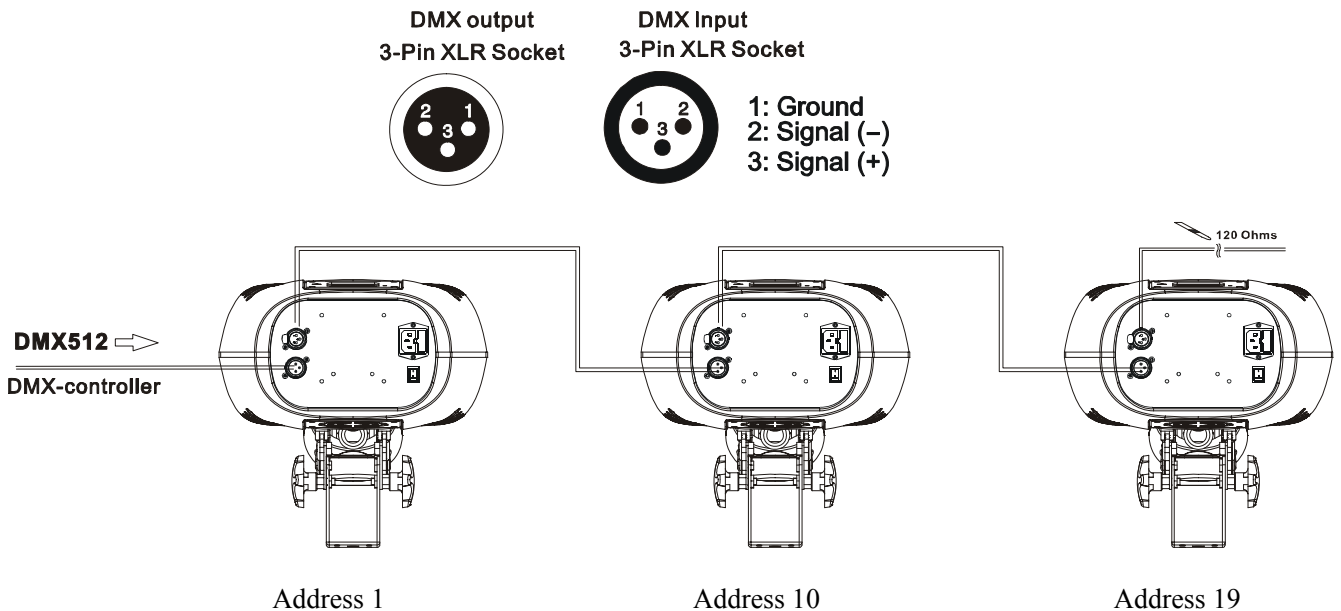

DMX-512 connection with DMX terminator

For installations where the DMX cable has to run a long distance or is in an electrically noisy environment, such as in a discotheque, it is recommended to use a DMX terminator. This helps in preventing corruption of the digital control signal by electrical noise. The DMX terminator is simply an XLR plug with a 120 Ω resistor connected between pins 2 and 3, which is then plugged into the output XLR socket of the last fixture in the chain. Please see illustrations below.

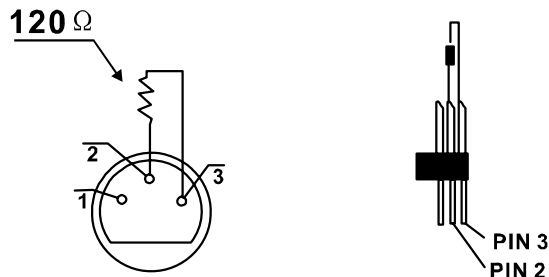

Projector DMX start address selection

All fixtures should be given a DMX starting address when using a DMX signal, so that the correct fixture responds to the correct control signals. This digital starting address is the channel number from which the fixture starts to “listen” to the digital control information sent out from the DMX controller. The allocation of this starting address is achieved by setting the correct number on the display located on the base of the device.

You can set the same starting address for all fixtures or a group of fixtures, or make different address for each fixture individually.

If you set the same address, all the units will start to “listen” to the same control signal from the same channel number. In other words, changing the settings of one channel will affect all the fixtures simultaneously.

If you set a different address, each unit will start to “listen” to the channel number you have set, based on the quantity of control channels of the unit. That means changing the settings of one channel will affect only the selected fixture.

In the case of the scanner, which is 9 channel fixture, you should set the starting address of the first unit to 1, the second unit to 10 (9 + 1), the third to 19 (10 + 9), and so on.

Note:

The modes of DMX 512 data are shown via the display:

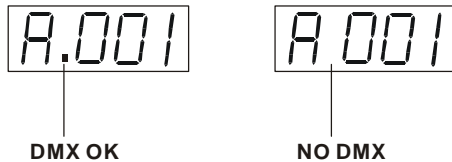

1. After switching on, the device will automatically detect whether DMX 512 data is received or not. If the data is received, the display will show "A.001" with the actually set address. If there is no data received at the DMX-input, the display will flash "A001" with the actually set address.

This situation can occur if:

- the 3 PIN XLR plug (cable with DMX signal from controller) is not connected with the input of the device.
- the controller is switched off or defective, if the cable or connector is defective or the signal wires are swap in the input connector.

It's necessary to insert the XLR termination plug (with 120 Ohm) in the last lighting in the link in order to ensure proper transmission on the DMX data link.

Control Board

There are four keys on the control panel , which could be used to set the address, turn ON/OFF, operating the program and reset.

[**Mode/Esc**] press this key to enter into edit mode. Press this key under the edit mode if you want to return to previous menu. it will exit from edit mode 60 seconds after the last keypress

[UP] screen will flash when pressing this key in normal mode, the address value will increasing. Keep pressing this key, the address value will increase rapidly. it will exit from flash 60 seconds after the last keypress. Press this key under edit mode, you can choose the function you want from the bottom up in the menu.

[DOWN] screen will flash when pressing this key in normal mode, the address value will idecreasing. Keep pressing this key, the address value will decrease rapidly. it will exit from flash 60 seconds after the last keypress. Press this key under edit mode, you can choose the function you want from the top down in the menu.

[ENTER] this key is functionless when in normal mode. Press this key under the edit mode, it will enter into next menu.

0	MODE	ADDR	VALU	A001~A511 (AXXX)	DMX address setting
			SLAV	ON/OFF (SLAV)	Slave setting
			EBOC	ON/OFF	Change DMX address via external controller
		RUN	AUTO	ALON (AU-A)	Automatic Run in Stand Alone
				MAST (AU-M)	Automatic Run as Master
			SOUN	ALON (SO-A)	Sound-controlled Run in Stand Alone
				MAST (SO-M)	Sound-controlled Run as Master
		DISP	VALU	D-XX D-00 (DXXX)	Display the DMX 512 value of each channel
			RDIS	ON/OFF	Reverse display
			CLDI	ON/OFF	Shut off LED display
			LOCK	ON/OFF	Key Lock
		2	SET	RPAN	ON/OFF
RTIL	ON/OFF			Tilt Reverse	
MIC	M-XX M-70			Mic sensitivity	
AUTO	Clos/Hold/Auto/Audi			No DMX Status	
FANS	HIGH/AUTO			Fan's mode select	
REST				Reset	
LODA	ON/OFF			Restore factory settings	
HIbE	OFF/1-99M 15M			Stand by mode	
3	ADJU	LADJ	ON/OFF	Lamp adjustment	
		TEST	T-01~T-XX	Test function of each channel	
		WHEL	CODE	CXXX	Fixture code *code is "C050"
			CH01~CHXX	XXXX(-128~127)	Motor Fix
4	TIME	MATI	0000~9999(hours)	Fixture running time	
		CLMT	ON/OFF (Password is 838)	Clear fixture time	
5	EDIT	STEP	S-01 ~S-48	Steps of Program Run	
		REC.	RE.XX	Auto Save Scene	
		SC01 ~ SC48	C-01~C-XX	XXX(000~255)	Edit the channels of each scene
			TIME	XXXX(000.2s~199.8s)	Time for each scene
			CNIN	ON/OFF	Edit program via controller

Default setting shaded.

Main Menu Functions

Main functions:

MODE - SET - ADJU - TIME - EDIT

MODE - Main menu 0

MODE - **Addr**
RUN
DISP

Press [MODE/ESC] to enter the main menu "MODE" (display flashing)
Press [ENTER] and select "ADDR", "RUN" or "DISP" by pressing [UP] or [DOWN] button.
Press [ENTER] for selecting the desired sub menu.

Addr - DMX address setting, Slave setting

MODE - **Addr** - **VALU** - **ADD 1-111111**
SLAV - **ON/OFF**
EBOC - **ON/OFF**

VALU - DMX address setting

With this function, you can adjust the desired DMX-address via the Control Board.
Select "VALU" by pressing [UP] or [DOWN] button.
Press [ENTER], adjust the DMX address by pressing [UP] or [DOWN] button.
Press [ENTER] to confirm or pressing [MODE/ESC] to return to main menu.

SLAV - Slave setting

With this function, you can define the device as slave.
Select "SLAV" by pressing [UP] or [DOWN] button.
Press [ENTER], the display shows "ON" or "OFF".
Press [UP] to select "ON" if you wish to enable this function or press [DOWN] to select "OFF" if you don't.
Press [ENTER] to confirm or press [MODE/ESC] to return to main menu.

EBOC - DMX address setting via controller

With this function, you can adjust the desired DMX-address via an external controller.
This function can only be activated when the DMX-value of all other channels is set to "0" on the controller.
Select "EBOC" by pressing [UP] or [DOWN].
Press [ENTER], the display shows "ON" or "OFF".
Press [UP] to select "ON" if you wish to enable this function or [DOWN] to select "OFF" if you don't.
Press [MODE/ESC] to confirm.
Press [ENTER] in order to return to the main menu.
On the controller, set the DMX-value of channel 1 to "7".
Set the DMX-value of channel 2 to "7" or "8". When set to "7" you can adjust the starting address between 1 and 255. When set to "8" you can adjust the starting address between 256 and 511.
Set the DMX-value of channel 3 to the desired starting address. If you want to set the starting address to 57, set channel 1 to "7", channel 2 to "7" and channel 3 to "57". If you want to set the starting address to 420, set channel 1 to "7", channel 2 to "8" and channel 3 to "164" (256+164=420).
Wait for approx. 20 seconds and the unit will carry out a reset. After that, the new starting address is set.

RUN - Program Run, Master setting

With the function "RUN", you can run the internal program. You can set the number of steps under Step. You can edit the individual scenes under Edit. You can run the individual scenes either automatically (AUTO), i.e. with the adjusted Step-Time or sound-controlled (SOUN). The selection "ALON" means Stand Alone-mode

and "MAST" that the device is defined as master.

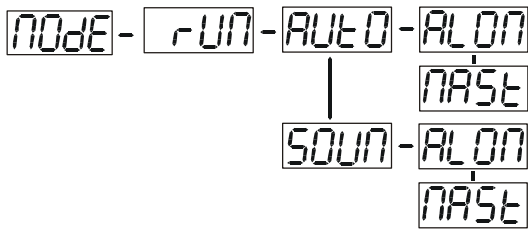

Select "AUTO" or "SOUN" by pressing [UP] or [DOWN] button.
 Press [ENTER] for selecting the desired extension menu.
 Select "ALON" or "MAST" by pressing [UP] or [DOWN] button.
 Press [ENTER] to confirm or Press [MODE/ESC] to return to the main menu.

DISP - Display the DMX-value, Reverse display, Shut off LED display



VALU - Display the DMX 512 value of each channel
 With this function you can display the DMX 512 value of each channel.
 Select "VALU" by pressing [UP] or [DOWN] button.
 Press [ENTER] to confirm; the display shows "D-00". In this setting, the DMX-adjustment of every channel will be displayed.
 Press [UP] or [DOWN] button in order to select the desired channel. If you select "D-14" the display will only show the DMX-value of the 14th channel.
 Press [ENTER] to confirm or Press [MODE/ESC] to return to the main menu.
 The display shows "D- XX", "X" stands for the DMX-value of the selected channel.

rdis - **Reverse display**
 With this function you can rotate the display by 180°.
 Select "RDIS" by pressing [UP] or [DOWN] button.
 Press [ENTER], the display shows "ON" or "OFF".
 Press [UP] to select "ON" if you wish to enable this function or press [DOWN] button to "OFF" if you don't; the display will rotate by 180°.
 Press [ENTER] to confirm or Press [MODE/ESC] to return to the main menu.

CLDI - **Shut off LED display**
 With this function you can shut off the LED display after 2 minutes.
 Select "CLDI" by pressing [UP] or [DOWN] button.
 Press [ENTER], the display shows "ON" or "OFF".
 Press [UP] to select "ON" if you wish to enable this function or press [DOWN] button to "OFF" if you don't.
 Press [ENTER] to confirm or Press [MODE/ESC] to return to the main menu.

LOCK - **Locked keys the display**
 With this function you can activate the automatic keylock function. If this function is activated, the keys will be locked automatically after exiting the edit mode for 15 seconds. keeping press the [Mode/Esc] key for 3seconds if you want to deactivate the keylock status.
 1. Tap the [UP] button until "LOCK" is displayed and tap the [ENTER] button.

2. Press the [UP] button to select “ON” to activate this function, or “OFF” to deactivate this function. Press [ENTER] to confirm.
3. Press [Mode/Esc] to return to the main menu.

SEt - Main menu 1

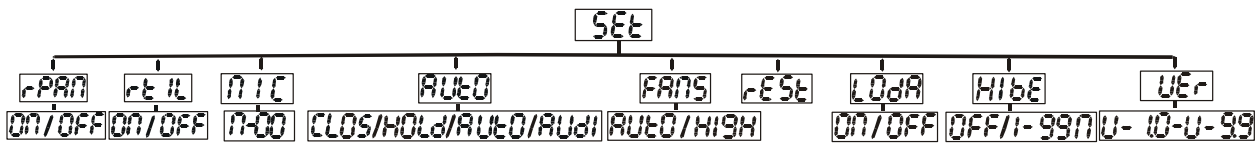

Press [MODE/ESC] to enter the main menu (display flashing).
Press [UP] or [DOWN] button. To select “SET”.

rPAN - Pan Reverse

With this function you can reverse the Pan-movement.
Select “RPAN” by pressing [UP] or [DOWN] button.
Press [ENTER], the display shows “ON” or “OFF”.
Press [UP] to select “ON” if you wish to enable this function or press [DOWN] button to “OFF” if you don’t.
Press [ENTER] to confirm or Press [MODE/ESC] to return to the main menu.

rEtIL - Tilt Reverse

With this function you can reverse the Tilt-movement.
Select “RTIL” by pressing [UP] or [DOWN] button.
Press [ENTER], the display shows “ON” or “OFF”.
Press [UP] to select “ON” if you wish to enable this function or press [DOWN] button to “OFF” if you don’t.
4. Press [ENTER] to confirm or Press [MODE/ESC] to return to the main menu.

nIC - Mic sensitivity

With this function you can adjust the sensitivity of the microphone.
1. Select “MIC” by pressing [UP] or [DOWN] button.
Press [ENTER], the display shows “M-XX”, “XX” stands for the number from 0 to 99.
3.. Press [ENTER] to confirm or Press [MODE/ESC] to return to the main menu.

AUtO - Automatic Run by no DMX

With this function you can automatic run the device by no DMX.
1. Select “AUTO” by pressing [UP] or [DOWN] button.
2. Press [ENTER], the display shows “CLOS”, “HOLD”, “AUTO” or “AUDI”.
3. Press [UP] or [DOWN] button to select “CLOS”, “HOLD”, “AUTO” or “AUDI”, the default is “HOLD”.
4. Press [ENTER] to confirm or Press [MODE/ESC] to return to the main menu.

FANS - Fan’s mode select

With this function you can select the Fan’s mode.
1. Select “FANS” by pressing [UP] or [DOWN] button.
2. Press [ENTER], the display shows “HIGH” or “AUTO”.
3. Select “HIGH” or “AUTO” by pressing [UP] or [DOWN] button.
4. Press [ENTER] to confirm or Press [MODE/ESC] to return to the main menu.

rESt - Reset

With this function you can reset the device via the Control Board.
Select “REST” by pressing [UP] or [DOWN] button.
Press [ENTER], the display shows “ON” or “OFF”.
Press [UP] to select “ON” if you wish to enable this function or “OFF” if you don’t.
Press [ENTER] to confirm or Press [MODE/ESC] to return to the main menu.

Press [ENTER] to confirm or Press [MODE/ESC] to return to the main menu.

WHEL

- Fixture code and motor fix

1. Select "WHEL" by pressing [UP] or [DOWN] button.
2. Press [ENTER], the display shows "CODE" or "CH01-CHXX".
4. Select "CODE" or "CH01-CH-XX" by pressing [UP] or [DOWN] button.
5. Press [ENTER] to confirm or Press [MODE/ESC] to return to the main menu.

TIME

- Main menu 3

MATI - 0000-9999

LATI - 0000-9999

CLMT - ON/OFF

Press [MODE/ESC] to enter the main menu (display flashing).

Press [UP] or [DOWN] button to select "TIME".

MATI

- Fixture running time

With this function you can display the running time of the device.

Select "MATI" by pressing [UP] or [DOWN] button.

Press [ENTER], the display shows "XXXX", "X" stands for the number of hours.

Press [ENTER] to confirm or Press [MODE/ESC] to return to the main menu.

LATI

- Lamp running time

With this function you can display the running time of the lamp.

Select "LATI" by pressing [UP] button.

Press [ENTER], the display shows "XXXX", "X" stands for the number of hours.

Press [MODE/ESC] to return to the main menu.

CLMT

- Clear fixture time

With this function you can clear the running time of the device.

Select "CLMT" by pressing [UP] or [DOWN] button.

Press [ENTER], the display shows "ON" or "OFF".

Press [UP] to select "ON" if you wish to enable this function or press [DOWN] button to "OFF" if you don't.

Press [ENTER] to confirm or Press [MODE/ESC] to return to the main menu.

Ed It - Main menu 4

1. Press [MODE/ESC] to enter the main menu (display flashing).
2. Press [UP] or [DOWN] button to select "EDIT".

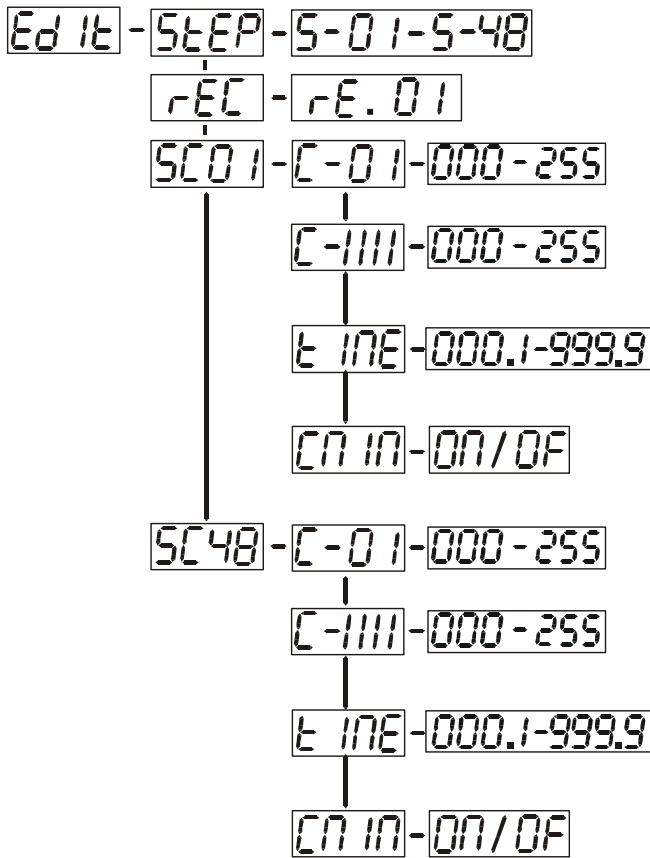

STEP - Define the number of steps in Run

With this function you can define the number of steps in the Program Run.

Select "STEP" by pressing [UP] or [DOWN] button.

Press [ENTER], the display shows "S-XX", "X" stands for the total amount of steps you want to save, so you can call up to 48 scenes in "RUN". For example if the "XX" is 05, it means that "RUN" will run the first 5 scenes you saved in "EDIT".

Press [ENTER] to confirm or Press [MODE/ESC] to return to the main menu.

rEC - Auto Save

With this function you can automatic save the number of steps in the Program Run.

Select "REC" by pressing [UP] or [DOWN] button.

Press [ENTER], the display shows "RE.XX", "XX" stands for the number from 1 to 400.

Press [ENTER] to confirm or Press [MODE/ESC] to return to the main menu.

SC01 - Editing the channels of the individual scenes

With this function you can edit the program to be called up in Run.

a) Editing via the Control Board

Select "SC01" by pressing [UP] or [DOWN] button.

Press [ENTER], the display shows "SCXX", "X" stands for the scene no. to be edited.

Change the scene no. by pressing [UP] or [DOWN] button.

Press [ENTER], the display shows "C-X", "X" stands for the channel no. Such as "C-01", it means you are editing channel 1 of the selected scene.

Select the channel no. you would like to edit by pressing [UP] or [DOWN] button.

Press [ENTER] to enter editing for the selected channel, the fixture reacts to your settings. The display shows the DMX value of the edited channel. Such as "11XX", it stands for in the channel 11 of the editing scene, the DMX value is XX, XX is a hexadecimal number value "01-FF". Adjust the desired DMX value by pressing [UP] or [DOWN] button.

Press [ENTER] in order to edit other channels of this scene.

Repeat steps 5-9 until you finish setting all the DMX values for all channels of this scene.

Once all the channels completed, the display will flash "TIME"

Press [ENTER] to edit the time needed, the display shows "XXXX", "XXXX" stands for the time needed to run the current scene, value "000.2s~199.8s".

Adjust the desired time by pressing [UP] or [DOWN] button.

Press [ENTER] to save the settings for the scene you are editing, the display will change to the next scene automatically.

Repeat step 3-14 to edit and other scenes, you can edit and save a maximum of 48 scenes.

Press [MODE/ESC] to exit. The number of steps can be defined under "STEP" and the scenes can be called up under "RUN"

b) Editing via the external controller

Call up the first scene in your controller now.

Select "SC01" by pressing [UP] or [DOWN] button.

Press [ENTER], the display shows "SC01".

Press [ENTER], the display shows "C-01".

Select "CNIN" by pressing [UP] or [DOWN] button.

Press [ENTER], the display shows "OFF".

Press [UP] or [DOWN] button .the display shows "ON".

Press [ENTER], the display shows "SC02". You successfully downloaded the first scene.

Adjust the Step-time as described above under point 12.

Call up the second scene in your controller now.

Repeat steps 5-11 until all desired scenes are downloaded.

Press [MODE/ESC] to exit. The number of steps can be defined under "STEP" and the scenes can be called up under "RUN"

INSTRUCTIONS ON USE:

DMX channel's functions and their values (9 DMX channels):		
Channel	Value	Function
1		<u>Color Wheel 1 :</u>
	0-14	Open / white
	15-29	COL 1
	30-44	COL 2
	45-59	COL 3
	60-74	COL 4
	75-89	COL 5
	90-104	COL 6
	105-119	COL 7
	120-127	COL 8
	128-189	Forwards rainbow effect from fast to slow
	190-193	No rotation
	194-255	Backwards rainbow effect from slow to fast
2		<u>Rotating gobos, cont. rotation :</u>
	0-9	Open
	10-19	Rot. gobo 1 (metal)
	20-29	Rot. gobo 2 (metal)
	30-39	Rot. gobo 3 (metal)
	40-49	Rot. gobo 4 (metal)
	50-59	Rot. gobo 5 (metal)
	60-69	Rot. gobo 6 (metal)
	70-79	Rot. gobo 7 (metal)
	80-95	Rot. gobo 1 (metal) shake
	96-111	Rot. gobo 2 (metal) shake
	112-127	Rot. gobo 3 (metal) shake
	128-143	Rot. gobo 4 (metal) shake
144-159	Rot. gobo 5 (metal) shake	

	160-175	Rot. gobo 6 (metal) shake
	176-191	Rot. gobo 7 (metal) shake
	192-255	Rot. gobo wheel cont. rotation slow to fast
3		<u>Rotating gobo index, rotating gobo rotation :</u>
	0-127	Gobo indexing
	128-189	Forwards gobo rotation from fast to slow
	190-193	No rotation
	194-255	Backwards gobo rotation from slow to fast
4		<u>Speed Pan/Tilt movement:</u>
	0-225	Max to min speed
	226-235	Blackout by movement
	236-245	Blackout by all wheel changing
	246-255	No function
5		<u>PAN Movement 8bit :</u>
	0-255	Pan Movement
6		<u>TILT Movement 8bit :</u>
	0-255	Tilt Movement
7		<u>Shutter, strobe:</u>
	0-31	Shutter closed
	32-63	No function (shutter open)
	64-95	Strobe effect slow to fast
	96-127	No function (shutter open)
	128-159	Pulse-effect in sequences
	160-191	No function (shutter open)
	192-223	Random strobe effect slow to fast
	224-255	No function (shutter open)
8		<u>Dimmer intensity:</u>
	0-255	Intensity 0 to 100%
9		<u>reset, internal programs:</u>
	0-19	Colour change normal
	20-39	Colour change to any position
	40-79	No Function
	80-99	Motor reset
	100-119	Internal program 1
	120-139	Internal program 2
	140-159	Internal program 3
	160-179	Internal program 4
	180-199	Internal program 5
	200-219	Internal program 6
	220-239	Internal program 7
	240-255	Internal program 8

ERROR MESSAGE

When you turn on the fixture, it will make a reset at first. The display may show “Err channel is XX” while there are problems with one or more channels. “XX” stands for channel 1, 2, 3, 5, 6 who has the testing sensor for positioning. For example, when the display shows “02 Er”, it means there is some error in channel 2. If there are some errors on channel 1, channel 2, channel 3 at the same time, you may see the error message “01 Er”, “02 Er”, “03 Er” flash repeated for 2 times, and then the fixture will generate a second reset. If the fixture remain error message after performing reset more than 2 times, only the channels which have errors can not work properly, others can work as usual. Please contact with dealer or manufacturer for service, self repair is not allowed.

Color Wheel 1- movement Er

(COLOR WHEEL 1-yoke movement error) This message will appear after the reset of the fixture if the yoke’s magnetic-indexing circuit malfunction (sensor failed or magnet missing) or the stepping-motor is defective (or its driving IC on the main PCB). The PAN- movement is not located in the default position after the reset.

Rotating gobos - movement Er

(ROTATING GOBOS-yoke movement error) This message will appear after the reset of the fixture if the yoke’s magnetic-indexing circuit malfunction (sensor failed or magnet missing) or the stepping-motor is defective (or its driving IC on the main PCB). The PAN- movement is not located in the default position after the reset.

Gobos rotation - movement Er

(GOBOS ROTATION -yoke movement error) This message will appear after the reset of the fixture if the yoke’s magnetic-indexing circuit malfunction (sensor failed or magnet missing) or the stepping-motor is defective (or its driving IC on the main PCB). The PAN- movement is not located in the default position after the reset.

CLEANING AND MAINTENANCE

The following points have to be considered during the inspection:

- 1) All screws for installing the devices or parts of the device have to be tightly connected and must not be corroded.
- 2) There must not be any deformations on the housing, color lenses, fixations and installation spots (ceiling, suspension, trussing).

Mechanically moved parts must not show any traces of wearing and must not rotate with unbalances.

The electric power supply cables must not show any damage, material fatigue or sediments.

Further instructions depending on the installation spot and usage have to be adhered by a skilled installer and any safety problems have to be removed.



CAUTION!

Disconnect from mains before starting maintenance operation.

In order to make the lights in good condition and extend the life time, we suggest a regular cleaning to the lights.

- 1) Clean the inside and outside lens each week to avoid the weakness of the lights due to accumulation of dust.
- 2) Clean the fan each week.
- 3) To make sure the smooth gobo rotation, we suggest adding proper lube to the wheel each three month, avoiding the excessive lube splashes during the gobo rotating.
- 4) A detailed electric check by approved electrical engineer each three month, make sure that the circuit contacts are in good condition, prevent the poor contact of circuit from overheating.

We recommend a frequent cleaning of the device. Please use a moist, lint- free cloth. Never use alcohol or

solvents.

Should you need any spare parts, please order genuine parts from your local dealer.

TECHNICAL SPECIFICATIONS

Power supply:

AC 100V~ 50Hz; AC 120V~ 50Hz; AC 208V~ 50Hz; AC 220V~ 50Hz; AC 230V~ 50Hz; AC 240 V~ 50Hz;

AC 100V~ 60Hz; AC 120V~ 60Hz; AC 208V~ 60Hz; AC 220V~ 60Hz; AC 230V~ 60Hz; AC 240 V~ 60Hz;

Power consumption: max. 80W

Packing dimensions: 67.5 x 37 x 33cm

Net weight: 7.6KGS

Gross weight: 10.3KGS

Remark: errors and omissions for every information given in this manual excepted. All information is subject to change without prior notice.