

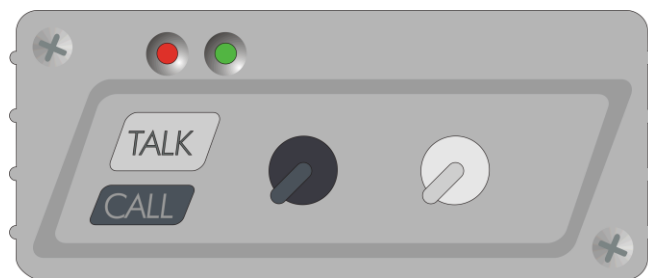

**PS 19 AM
SINGLE CHANNEL BELTPACK
WITH PGM (AUX) INPUT**



USER MANUAL

Issue 2011 © ASL Intercom BV

DESIGNED AND MANUFACTURED BY:

ASL INTERCOM BV
ZONNEBAAN 42
3542 EG UTRECHT
THE NETHERLANDS
PHONE: +31 (0)30 2411901
FAX: +31 (0)30 2667373
E-MAIL: info@asl-inter.com
WEB: www.asl-inter.com

CONTENT OF THIS USER MANUAL

1.0	GENERAL DESCRIPTION	2
2.0	UNPACKING	2
3.0	INSTALLATION.....	2
4.0	WARRANTY.....	2
5.0	FRONT PANEL CONTROLS	3
6.0	REAR PANEL CONNECTORS	3
7.0	BOTTOM PANEL CONTROLS	4
8.0	TECHNICAL SPECIFICATIONS PS 19 AM	4
9.0	PART LINE, TECHNICAL CONCEPT	5
10.0	CABLING.....	5
11.0	BLOCK DIAGRAM PS 19 AM	6
12.0	SYSTEM CONFIGURATION	6
13.0	EARTHING CONCEPT	7

1.0 GENERAL DESCRIPTION

The PS 19 AM is a portable single channel intercom station, equipped with a volume controlled input for external (program) audio signals. It is housed in a strong metal case provided with a steel belt clip.

On the front panel are a Volume (listen level) control for the intercom signals, a Volume control for the PGM signals, a TALK push button with LED indicator and a CALL push button with LED indicator.

On the bottom panel are a side tone trimmer, a buzzer volume trimmer, a mic gain trimmer and a PGM Line/Mic level selector.

On the rear panel are an XLR-3 connector for the intercom connection cable (the 'party line'), an XLR-3 connector for the external program audio and an XLR-4 connector for the headset.

The program (PGM) audio is only heard at the local headset (not sent to the intercom line)

Optionally an XLR-5 headset connector can be fitted allowing the user to hear the intercom

signal at the left headset can and the PGM signal at the right headset can.

Special attention has been paid to the intelligibility of speech. By applying low noise / high speed op-amps, a speech presence filter and propriety high power bridged headphone amplifiers, communication is very comfortable even in environments with a high level of background noise.

The unique ASL call system provides both a flashing red LED and a very distinctive sound signal. A momentary push of the Call button makes the red LED flash whilst holding the button for 2 seconds activates the Call sound signal. The volume of this sound signal (the buzzer) can be adjusted at the front panel.

Fully electronic switching increases reliability and allows for:

- 'soft' microphone On switching, latched or momentary
- Remote Mic Mute facility

2.0 UNPACKING

The shipping carton contains the PS 19 AM and this user manual. If any are missing, contact your dealer.

ASL has taken great care to ensure this product reaches you in flawless condition.

After unpacking the unit please inspect for any physical damage and retain the shipping carton and relevant packing materials for use should the unit need returning.

If any damage has occurred, please notify your dealer immediately so that a written claim can be initiated. Please also refer to the warranty section of this manual.

3.0 INSTALLATION

This PS 19 AM will form a part of an existing or new intercom system. Connection to it is straightforward. There are no separate power connections or batteries to install as the necessary DC voltages are derived from the intercom master station or power supply, via the intercom connection cable.

To connect the PS 19 AM to the intercom system use professional flexible microphone cable with 2 wires and 1 shield only. Connect this cable to the LINE connector on the rear panel.

The PS 19 AM is fully protected against eventual wiring mistakes (reverse power) or short circuit in the interconnecting cables.

4.0 WARRANTY

This unit is warranted by ASL to the original end-user purchaser against defects in workmanship and materials in its manufacture for a period of 12 months from date of shipment to the end-user.

Faults arising from misuse, unauthorized modifications or accidents are not covered by this warranty. If the unit is faulty it should be sent, in its original packing, to your local ASL dealer, shipping costs prepaid. A note must be included stating the fault(s) found and a copy of the original suppliers invoice.

5.0 FRONT PANEL CONTROLS

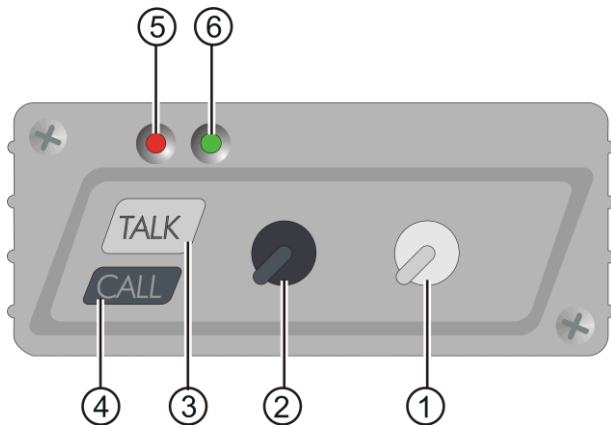

1 PGM VOLUME control knob

This knob is for adjusting the listen level of the PGM input signal.

2 VOLUME control knob

This knob is for adjusting the listen level of the intercom signal.

3 TALK button

By pushing this button the signal of the headset microphone is sent to the intercom party line. When the TALK button is switched On, its large green LED is lit.

Momentary switching:

When the TALK button is pushed and held, the microphone signal is sent to the intercom channel until the button is released.

Latched switching:

When the TALK button is pushed shortly it is electronically latched and the microphone signal is sent to the intercom channel.

When pushed again, the TALK button switches Off.

Mic Mute when latched On:

After a so-called Mic Mute signal has been received from a Pro Series master station or power supply, the connection between microphone and intercom channel is interrupted. By pushing the TALK button, the connection is restored and one can talk to the intercom channel again.

4 CALL button

With a momentary push of the CALL button, a Call signal is sent to all stations connected to the intercom party line. The Call LED's of this beltback and of all stations on the party line start flashing. By pushing the Call button for 2 seconds the Call Buzzers are activated, provided the buzzers are not muted by a Buzzer Mute signal received from a Pro Series master station or power supply.

After the CALL button is released the LED's continue to flash for a further 2 seconds.

5. Call LED (red)

6. Talk LED (green)

6.0 REAR PANEL CONNECTORS

7 PGM connector

This XLR-3 connector is for feeding PGM signals into the PS 19 AM. The input is electronically balanced and accepts audio levels between -18 dBu and +22 dBu when line level is selected or between -38 dBu and +2 dBu when mic level is selected. See also line/mic selector (#13)

Pin assignment:

Pin 1: 0V/ground

Pin 2: signal (+)

Pin 3: signal (-)

8 LINE connector

This XLR-3 connector is for connecting the PS 19 AM to the intercom party line.

Pin assignment:

Pin 1: 0V / ground shield

Pin 2: +30V DC power wire

Pin 3: audio wire

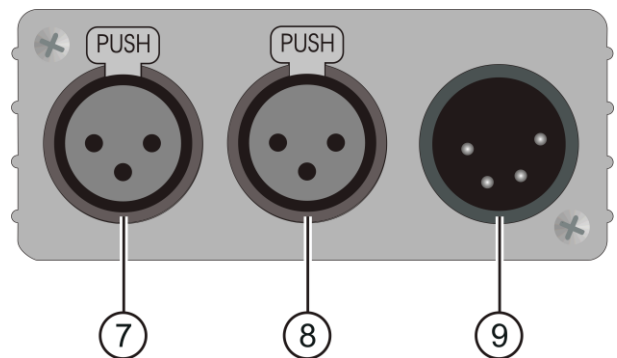

9 HEADSET connector

This XLR-4 connector is for connecting a headset to the beltback. The impedance of the headset can must be minimum 200 ohms; in case of 2 cans in parallel, the impedance of each can must be minimum 400 ohms.

Pin assignment:

Pin 1: shield mic. (GND)

Pin 2: mic. (+)

Pin 3: phones (+)

Pin 4: phones (-)

7.0 BOTTOM PANEL CONTROLS

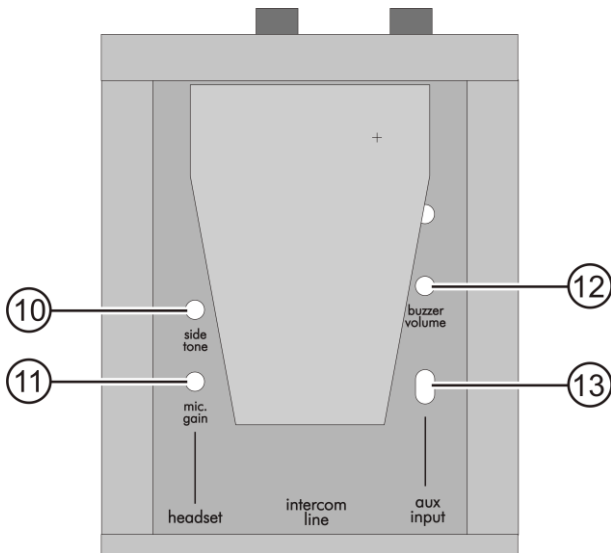

10 SIDE TONE trimmer

This trimmer adjusts the level of your own voice in your headset.

Adjustment procedure:

- Set trimmer in start position: turn fully clockwise
- Switch Off the microphones of all (speaker) stations connected to the party line

- Push the TALK button
- Turn up the listen volume
- Speak into the headset microphone
- Adjust the listen level by turning the side tone trimmer

The trimmer operating area is between fully clockwise and minimum level. Adjusting the side tone does not affect the level of your voice as heard by the other stations on the party line.

11 MIC GAIN trimmer

This trimmer is to adjust the headset mic gain between 35 dB – 60 dB

12 BUZZER VOLUME trimmer

This trimmer adjusts the volume of the internal buzzer. The buzzer is activated when the CALL button on this beltpack (or on any other intercom station connected to the party line) is pushed longer than 2 seconds, provided the buzzers are not muted by a Buzzer Mute signal received from a Pro Series master station or power supply.

13 PGM Line/Mic selector

To adjust the PGM input for either Mic or Line level of the incoming PGM audio signal.

8.0 TECHNICAL SPECIFICATIONS PS 19 AM

System

Dynamic range: 80 dB (1 kHz, THD , 1%)
Call signal: 2.8 mA
Call signal threshold (receive): +2.4V DC
Supply voltage: + 30V DC (12 – 32V DC)
Power interrupt time (mic mute): 0.1 sec

Intercom party line

Impedance: 350 Ω (1 kHz) / 2.2 k Ω (DC)
Audio level: nom. -18 dBu, max. +4 dBu

Mic pre-amp

Headset mic. impedance: 200 Ω
Gain: 35 – 60 dB (adjustable internally)
Presence filter: +6 dB at 5 kHz
Frequency response: 200Hz - 15 kHz (-3 dB)
Power to electret mic: +9V DC

Headphone Driver Amps

Max. load: 200 Ω
Max output level:
monaural: 14 V_{rms} @ 200 Ω
binaural: 2x 0.16 V_{rms} @ 400 Ω
Max output power:
monaural: 1 W_{rms} @ 200 Ω
binaural: 2x 0.28 W_{rms} @ 400 Ω

Side Tone

Rejection: 0 – 30 dB adjustable

Buzzer

Max. SPL: 85 dBA

PGM input

Input impedance:
30 k Ω (balanced line level)
4.6 k Ω (balanced mic level)
Nominal input level:
-18 dBu to +6 dBu (line level)
-38 dBu to -14 dBu (mic level)
Max. input level:
+22 dBu (line level)
+2 dBu (mic level)

PS 19 AM Power Consumption

Current (at 30V DC):
30 mA quiescent
45 mA signaling
170 mA at max. output + signaling

PS 19 AM Dimensions & Weight

Width: 90 mm / Height: 48 mm (incl. clip)
Depth: 124 mm / Weight: 400 grams

0 dB is defined as 775 mV into open circuit.
ASL reserves the right to alter specifications without prior notice.

9.0 PART LINE, TECHNICAL CONCEPT

User stations in an ASL intercom system are interconnected via one or several 'party lines'. A party line offers two way ('full' duplex) communication and consists of standard microphone (multi-pair) cable. One wire is used for the audio signal and one wire for the DC power. The screen of the microphone cable functions as earth/return. Current drive is used for signal transfer. Each intercom station utilizes a current amplifier to amplify the microphone signal. That signal is put on the common audio line. Due to the constant line impedance, a signal voltage is developed which can be further amplified and sent to headphones or loudspeakers. The line impedance is situated in the power supply between XLR pin 3 and pin 1.

This principle has the following advantages:

- The use of a single audio line allows several intercom stations to talk and listen simultaneously
- Due to the high bridging impedance offered by each intercom station. The number of stations on the party line has no influence on the level of the communications audio signal.
- Power and audio to the intercom stations use the same cable

Also the Call signal is sent as a current, on the audio wire. It develops a DC potential over the line impedance which is sensed by each intercom station and interpreted as a Call signal.

10.0 CABLING

The ASL analog intercom stations, power supplies, interfaces and accessories are interconnected by cables of the shielded two-conductor microphone cable type. The intercom party line connectors are of the XLR-3 type. Audio and Call signals are on XLR pin 3, DC power is on XLR pin 2. XLR pin 1 is connected to the cable shield which functions as the common return for audio and power.

Since the audio signal is transferred in an unbalanced way (see Party Line, Technical Concept), certain rules have to be obeyed when installing the cabling of an intercom network. This is to avoid earth loops and to minimize power loss and the possible effect of electromagnetic fields.

Use high quality cable

Use high quality microphone cable (shielded two conductor cable, minimum 2x 0.30 mm²).

In case of a multi channel intercom network, use high quality microphone 'multi-pair' cable only, each pair consisting of two conductors (minimum 2x 0.15 mm²) with separate shield. Multi-pair cable should have an overall shield as well.

Use flexible cable

Use flexible single and multi-pair microphone cable instead of cable with solid cores, especially when the cable is subjected to bending during operation or installation.

Cable screens to XLR pin 1

The screen of each separate microphone cable and/or the screen of each single pair in a multi-pair cable, should be connected to pin 1 of each XLR-3 connector. Do not connect these screens to the metal housing of the master station or of the power supply or of XLR-2 wall boxes. See Earthing Concept.

Connect cable trunks, connection boxes and overall multi-pair cable screens to clean earth

Metal cable trunks, metal connection boxes and overall multi-pair cable screens should be interconnected and, at one point (the 'central earth point') in the intercom network only, be connected to a clean earth or a safety earth. See Earthing Concept.

Keep metal connection boxes and trunks isolated from other metal parts

Metal trunks or pipes for intercom cables and metal connection boxes should be mounted in such a way

that they are isolated from any other metal housing or construction part.

Keep cables parallel as much as possible

When two (multi channel) units in a network are connected by more than one cable, make sure that these cables are parallel to each other over the whole distance between those units. When using multi-pair cable, parallelism is ensured in the best possible way.

Avoid closed loops

Always avoid that intercom cables are making a loop. So-called 'ring intercom' should not physically be cabled as a ring.

Keep cables away from electromagnetic sources

Keep intercom cables away from high energy cables, e.g. 115/230/400V mains power or dimmer controlled feeds for spotlights. Intercom cables should cross high energy cables at an angle of 90° only. Intercom cables should never be in the same trunks as energy cables.

Place the power supply in a central position

In case of a system powered by a separate power supply: In order to diminish power losses, place the power supply as close as possible to where most power consumption occurs, in other words most user stations are placed.

Connect ASL power supplies to a 'clean' outlet

Master stations or power supplies should be connected to a mains outlet with a clean earth. Other audio equipment may be connected to this mains outlet, but avoid using an outlet which also power dimmer controlled lighting systems.

11.0 BLOCK DIAGRAM PS 19 AM

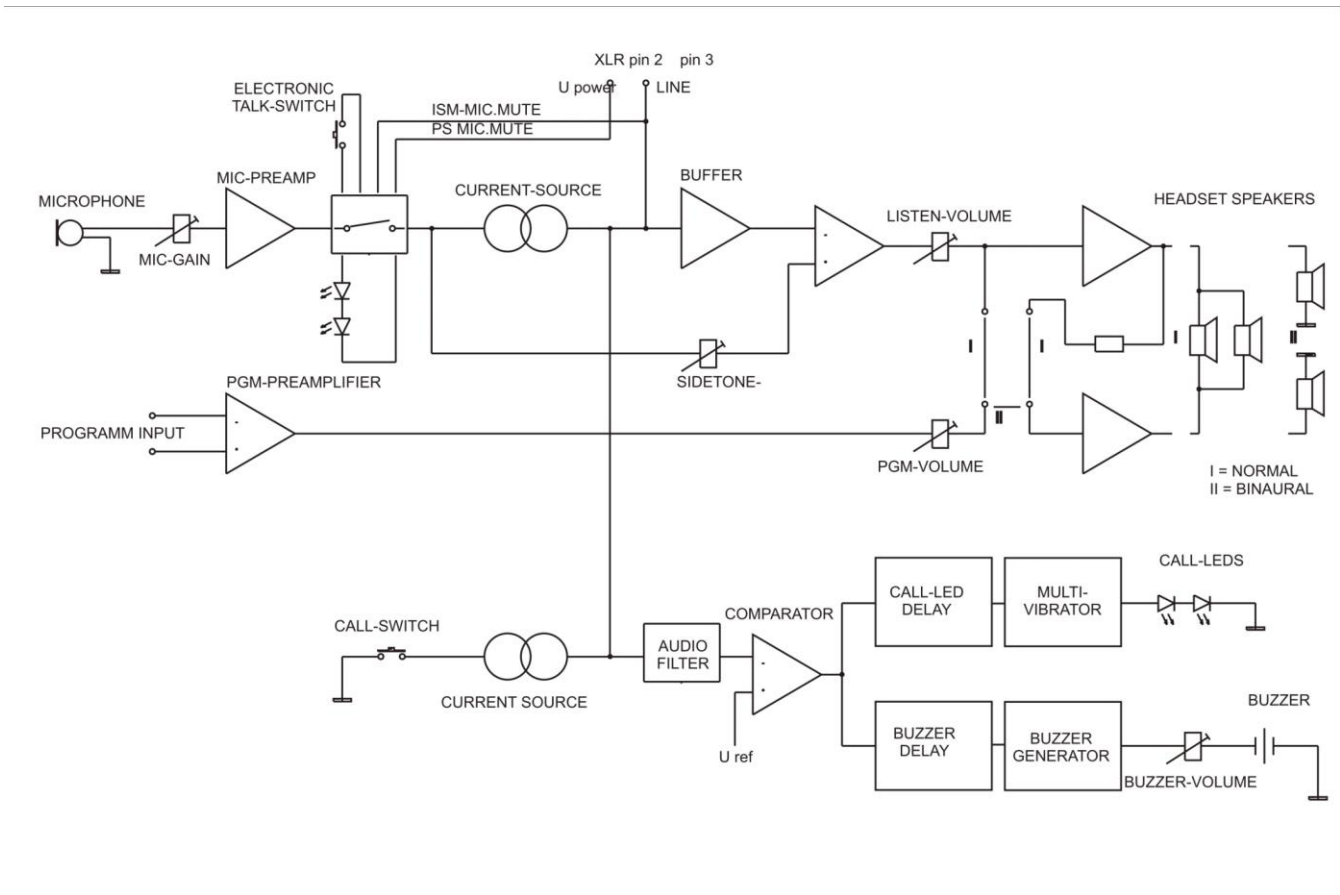

12.0 SYSTEM CONFIGURATION

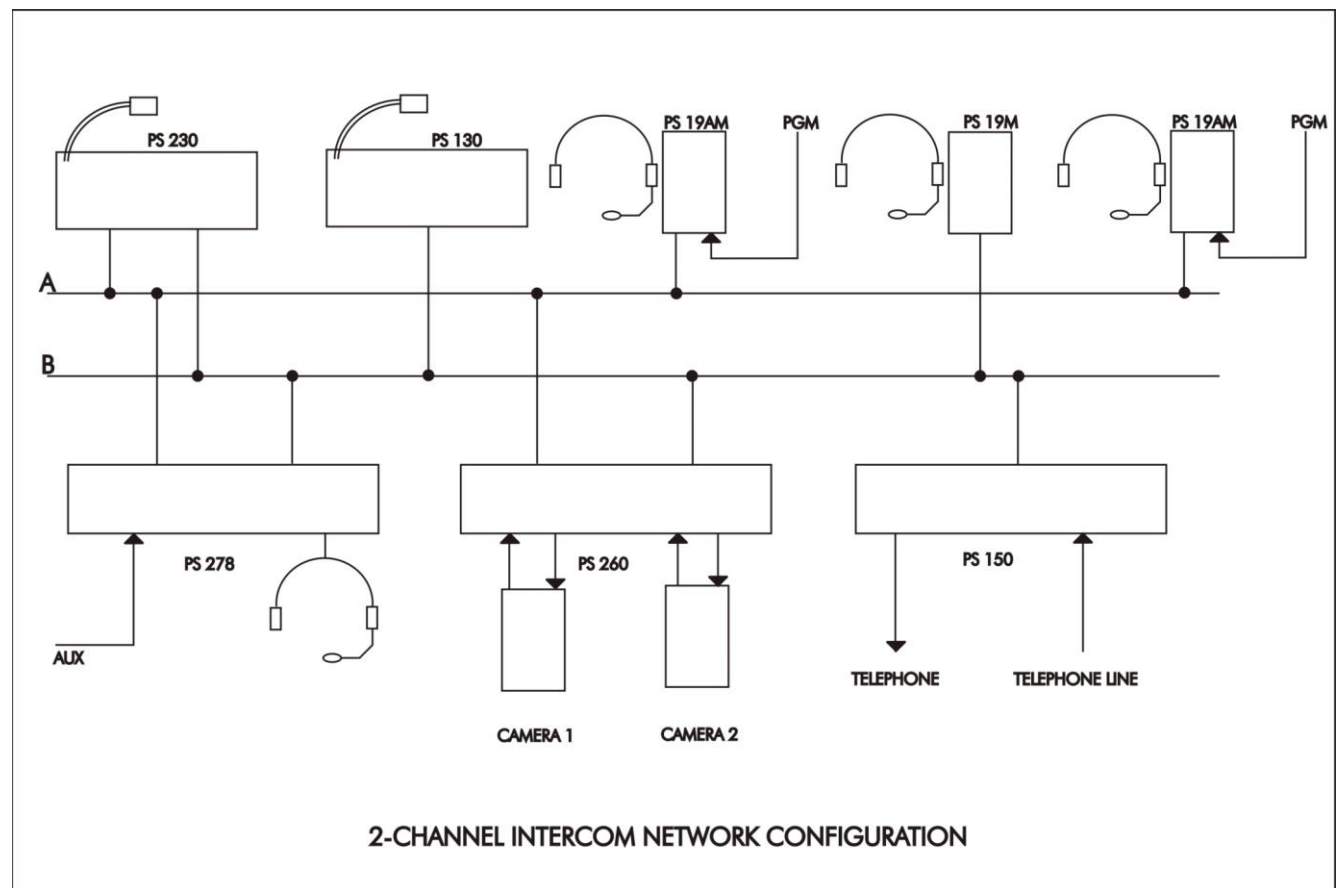

2-CHANNEL INTERCOM NETWORK CONFIGURATION

13.0 EARTHING CONCEPT

