

AQUAJOY PREMIER PLUS BATHLIFT



Read manual thoroughly before attempting to install or operate lift.

This manual has been provided to assist you with lift installation and operation. For further assistance please contact your authorized Harmar Access dealer or Harmar's Technical Services department.

Tel: 800.833.0478

Fax: 866.234.0478

Email: tech@harmar.com

04/5/2007

Dealer:

Serial Number:

Dear Customer

Congratulations on purchasing your AQUAJoy BATHLIFT.

The AQUAJoy BATHLIFT has been designed to help the end-user bath in complete safety and comfort. The AQUAJoy BATHLIFT can be used in the home, in multi-user environments and by healthcare professionals.

Please read the operating instructions carefully before using your bathlift. Please follow all instructions, particularly the safety instructions, at all times.

The AQUAJoy BATHLIFT comes with a complete one-year warranty including Battery Hand Control & Cover Mat. The warranty begins on the day of purchase.

We hope the AQUAJoy BATHLIFT makes a difference in your life and that having a bath is now much easier and safer for you.

The following components are part of the AQUAJoy BATHLIFT.

Back Frame

- 1. Seat back
- 2. Actuator
- 3. Actuator holder
- 4. Spindle shaft
- 5. Battery hand control
- 6. Hand control cable
- 7. Actuator cable

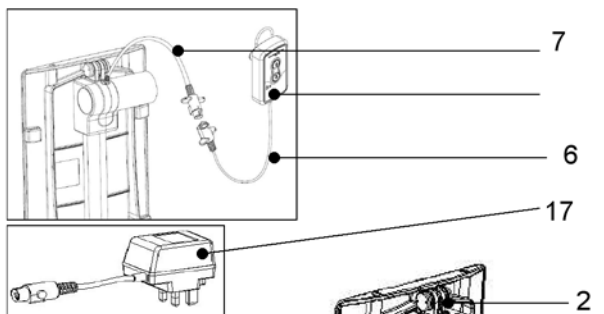

Complete Seat (base)

- 8. Seat base
- 9. Side flaps
- 10. Scissor parts
- 11. Slider
- 12. Base plate
- 13. Front suction cups
- 14. Middle suction cups
- 15. Rear suction cups
- 16. Tilting structure
- 17. Charger

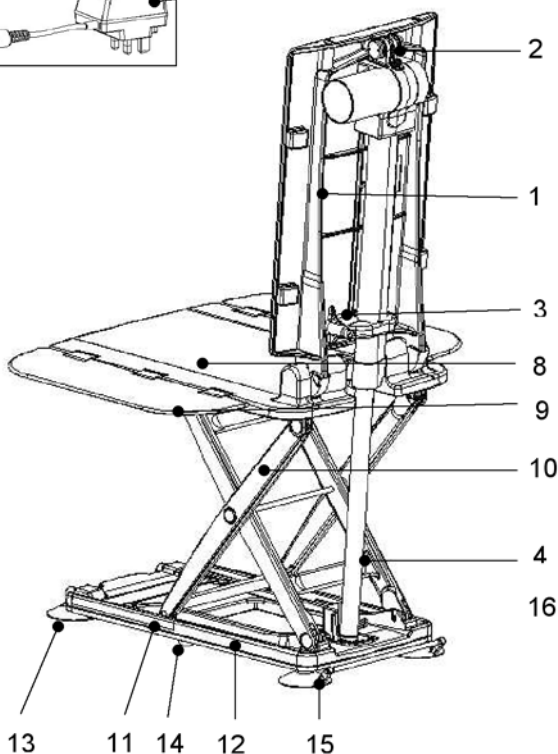

SAFETY INSTRUCTIONS

CAUTION

- The maximum capacity of the AQUAJLOY BATHLIFT is 375 lbs.
- The AQUAJLOY BATHLIFT may only be used to assist one person getting in and out of a bath.
- Before taking a bath, carry out a trial run to familiarize yourself with how the bathlift works.
- When necessary use the bathlift under the supervision of a care giver / family member.
- Always check the water temperature before bathing. The use of excessive amounts of bathing oils or salts will require the bathlift to be cleaned more frequently.
- Never reach between the base plate and the seat (hazard of hand becoming trapped in the scissor lifting mechanism).
- Always that check there are no obstructions in the mechanism before use.
- When installing your AQUAJLOY BATHLIFT, please ensure you place it at the opposite end of the water supply.
- When installing your bathlift, please ensure that you always align the backrest grooves flat onto the seat base correctly and lift from the center (as shown on next page.)
- Do not attach covers until assembly is complete.
- Please Note: If you have handles on your bath, please ensure you Attach the side flap diverters (plastic white strips packed with your Bathlift) to your bath handles.
- If sideflaps jam under bath handle “stop” lower the lift down, remove the interference and then bring the lift back to the top
- Carefully follow the Instructions on Page 3 when ever you assemble your bathlift.
- The AQUAJLOY BATHLIFT may only be used inside the bath to assist people to get in and out of the bath. It should not be used for climbing in and out; up or down; or as a support or lifting platform outside of the bath.
- The bathlift is not a toy and children should not be allowed to play with the lift.
- Never allow children to use the bathlift without adult supervision.
- Always disconnect hand control when backrest is folded flat.

ASSEMBLING THE AQUAJOY BATHLIFT

- The bath tub must be clean and dry before installing the bathlift.

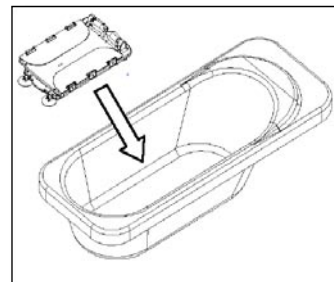

- Remove the bathlift parts from the box.

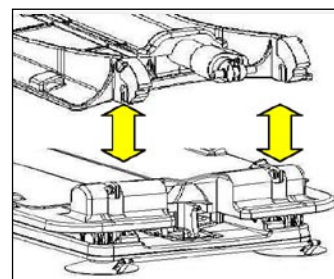

- Place the seat into the tub at the opposite end from the water faucet. Verify there is enough space for the bathlift to fully recline.

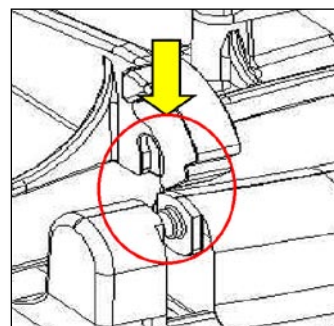

- Place the backrest flat on top of the seat. Match the grooves on the backrest to the grooves on the seat.

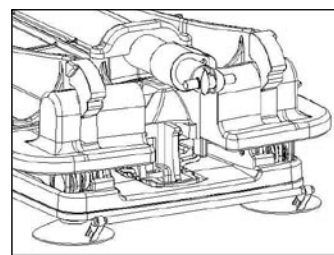

- Lift the backrest until it locks into the reclined position.

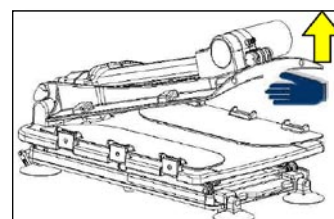

HOW TO CHARGE YOUR AQUAJoy BATHLIFT

- Before you first use your aquajoy bathlift, charge your hand control for twelve hours.
- Connect the battery hand control cable to the charger cable by matching the flat part of the connections together.
- Insert the charger plug into a wall socket.
- **Do not charge your battery hand control in your bathroom.**
- Charge your battery hand control after every bath.
- You can not overcharge your battery hand control.
- If the indicator light flashes red it means you do not have sufficient charge to use your bathlift.
- If you have not used your bath lift for over a week charge your battery hand control before bathing.

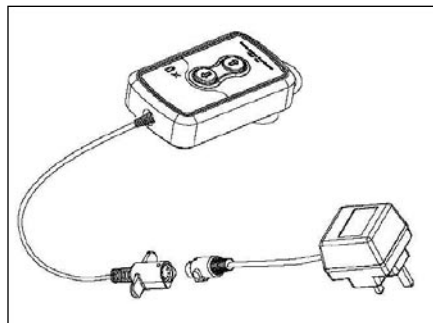

HOW TO BATHE WITH YOUR AQUAJOY BATHLIFT

- Assemble the lift as described on Page 3
- Connect the cable of the fully charged battery hand control to the cable on the back of the backrest. (Match the flat parts of the connections together).
- Fill bathtub with water.
- Push “up” button on the hand control to raise bath lift to the upper edge of bathtub. Release the “up” button when the seat of the lift is flush with the top of the tub.
- Sit on the lift perpendicular to the bathtub, and pull/swing each leg into the bathtub one at a time. Adjust yourself on the platform so that you are in a comfortable position for bathing.
- Once situated, press the “down” button to lower the platform into the bath. Release the button when you are at a comfortable height for bathing. If you continue to hold the down button the bath lift will recline 40 degrees once reached the lowest point.
- Bathe
- When finished bathing, press the “up” button on the hand control to raise the platform out of the water. Once the platform is level with the top of the bathtub, release the “up” button.
- After the platform is at the proper height, swing/pull each leg out and over the side of the bathtub, using caution as all surfaces maybe slippery. Finally, slide yourself off the platform and out of the tub.
- Empty water from bathtub.

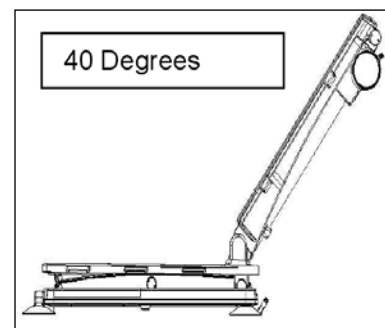
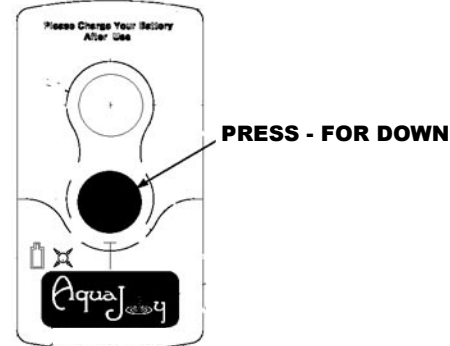
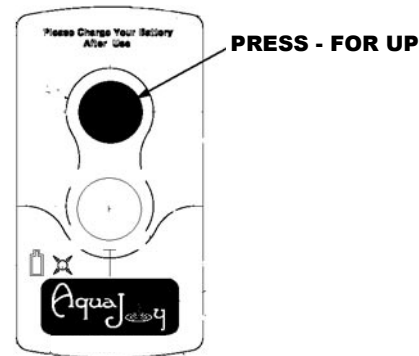

HOW TO REMOVE YOUR AQUAJOY BATHLIFT FROM YOUR BATH TUB

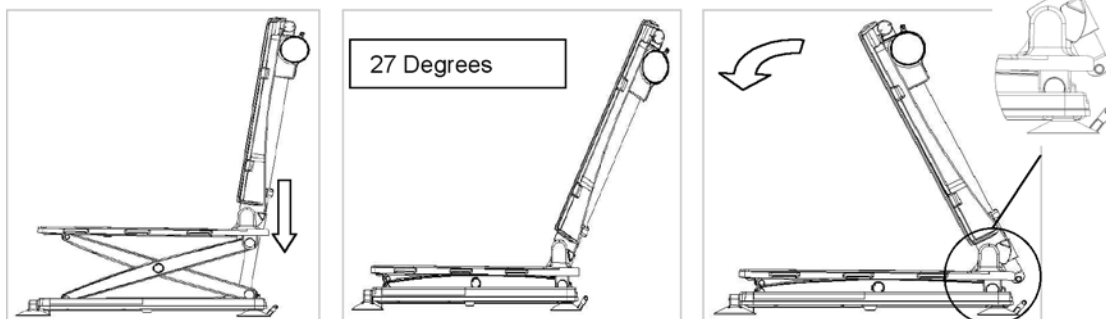

- Empty the water from the bath.
- Press the “down” button on the hand control and take the bathlift to its lowest position in the bath. Continue to press the down button until the backrest reaches an angle of approximately 27 degrees or more.
- Take hold of the two side flaps and fold them inward onto the seat.
- Take hold of the backrest and push it forward so that it lies flat on the seat (cover mat facing down).

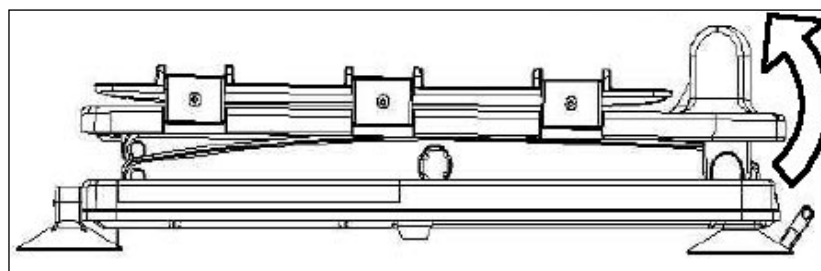
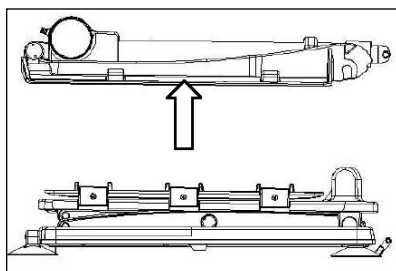

- With the backrest folded forward on the bathlift seat, simply detach the backrest from the base by lifting it upwards (as above). The backrest grooves will detach from the seat (base) grooves.
- To remove the seat (base), place one hand on the lifting bar at the rear of the base and lift to release the bathlift from the bath.
- Continue to lift and the suction feet at the front of the bathlift will release automatically. Place your other hand on the front of the bathlift and lift.
- Continue to lift your bathlift base out of the bath and you can now store it away.

SERVICE AND MAINTENANCE

If the AQUAJoy BATHLIFT is not used for 6 months the battery will require charging before the lift is used. Please follow the charging instructions on page 8 of this manual. The AQUAJoy BATHLIFT will not require any additional maintenance or servicing, other than periodic cleaning.

Cleaning

To Clean the AQUAJoy BATHLIFT , scrub with a household detergent and then wipe dry with a cloth. The AQUAJoy BATHLIFT should be stored in a dry place. The AQUAJoy BATHLIFT can be used with or without covers. The cover mats can be easily removed and washed in your washing machine up to a maximum temperature of 140°F (60°C).

Environmental Conditions for Use, Storage and Transport

Use:

- a) An ambient temperature range of 50 F° to 104F° (+10 C° to +40C°).
- b) A relative humidity range of 30% to 75%.
- c) An atmospheric Pressure range of 700hPa to 1060hPa

Storage and Transport:

- a) An ambient temperature range of -31F° to 122F° (-35 C° to 50C°).
- b) A relative humidity range of 10% to 100%.
- c) An atmospheric Pressure range of 300hPa to 1060hPa

EMI / RFI Warnings

The bath lift may be adversely affected by Electromagnetic Interference (EMI) and Radio Frequency Interference (RFI). Do not operate the following items within 10 feet of the bath lift; Cellular phones, mobile two-way radios, HAM radio transmitters, wireless computer links, microwave sources, paging transmitters.

FREQUENTLY ASKED QUESTIONS

Q.What should I do if the side flaps are obstructed by bath handles?

A.Install the side flap diverters over your tubs handles. The diverters ramp like shape will allow the side flaps to go past the handles.

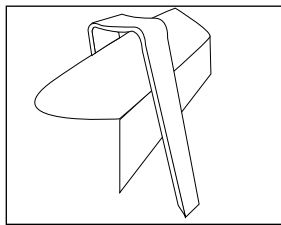
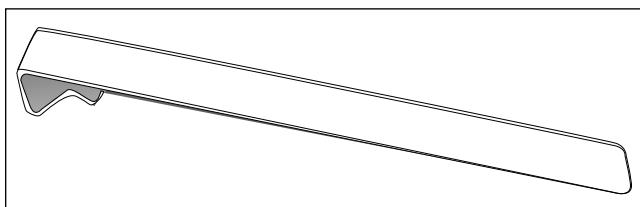

Q.My bathlift will run in the up direction but not in the down direction?

A.The bathlift will not run in the down direction if the battery needs to be recharged.

Q.How do I charge my battery hand control?

A.See the charging instructions on page 4.

Q.How do I wash my cover mats?

A.The AQUAJoy BATHLIFT **can be used with or without covers**. The cover mats can be easily removed and washed in your washing machine up to a maximum temperature of 60C° (140F°). However, the cover mats cannot be used in a tumble dryer, please hang them up to dry.

Q.Can I use emollients, moisturizer creams, and oils in the bath with my bathlift?

A.Yes, however, please ensure that you thoroughly rinse / clean away any residue from the base of the bath and the suction feet. We also recommend that you wash your cover mats more often when oils etcetera are used.

Q.If I leave my battery hand control on charge will I damage it?

A.No, charge your battery hand control for 12 hours when you first receive your bathlift. Then after every bath, leave the hand control on charge. You cannot overcharge your battery hand control. A fully charged battery will provide approximately fifteen full lifts up and down. There is also a safety mechanism on the lift to ensure it will not go down unless there is enough charge to raise it back up. This will ensure that you will not become stuck at the bottom of the bath.

BATTERY AND CHARGER

The battery hand control must not be thrown into a fire or stored in the vicinity of a fire. Dispose of old battery hand controls in the correct manner.

Do not open the battery hand control.

If possible, recharge the battery hand control immediately when it loses its charge.

Only use AQUAJoy BATHLIFT with the battery hand control supplied.

Only use the supplied battery charger to charge the supplied battery hand.

Do not charge your battery hand control inside the bathroom.

DISPOSAL

Be sure to dispose of all components (including the NiMH battery) according to local codes. Individual parts may be separated and disposed of according to the type of material and local recycling requirements.

Battery Replacement

The battery is an integral part of the hand control. In the unlikely case the battery ceases to function, the hand control will need to be replaced.

Please contact the dealer where you purchased your Bath lift for a replacement.

Serial Number Label

You will find all of the main technical data on the AQUAJoy BATHLIFT serial number label.

Actuator Label

Type: PA04420 10
 Serial Number: 000000000
 Max. Load: 3000N
 Power Rating: DC 13.2V I_{max} 7A
 IP Rating: IP 66
 Duty Cycle: Max. 5%, Max. 3min./hour

Manufacturer: Careline Corp.
 475-31, Bangbae-Dong,
 Socho-Ku, Seoul,
 Republic of Korea
 Tel: +82 2 3487 4300







Seat Label

Manufacturer: Careline Corp.
 475-31, Bangbae-Dong,
 Socho-ku, Seoul
 Republic of Korea
 Tel: +82 2 3487 4300

Type: Aquajoy
 Serial Number: 000000000
 Battery: DC 13.2V
 Protection Category: IP X5
 Max. load 170 Kgs
 Using Part: Type BP



Battery Hand Control Label

Serial Number: 000000000
Output: DC 13.2V 1300mAh
 Manufacture: Careline Corp.
 475-31, Bangbae-Dong,
 Socho-ku, Seoul
 Republic of Korea
 Tel: + 82 2 3487 4300



What do the symbols on the labels mean?



Storage temperature range



Recyclable

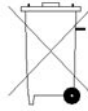

Dispose correctly



Caution 13.2v DC



Read instructions carefully

TECHNICAL DATA

Length of seat: 22.8 inches (580 mm)

Width of seat with extended seat side flaps: 27 inches (686 mm)

Width of seat with seat side flaps folded in: 15.3 inches (390 mm)

Height of seat in its lowest position: 3.5 inches (90 mm)

Height of seat in its highest position: 18.3 inches (465 mm)

Depth of seat measured from

Backrest to front seat edge: 19.3 inches (490 mm)

Height of backrest: 23.8 inches (604 mm)

Width of backrest: 13.4 inches (340 mm)

Carrying capacity: 375 lb (170kgs)

Total Weight without battery: 30 lb (13.64kg)

Weight of seat: 16.94 lb (7.70kg)

Weight of side flaps: 2.07 lb (0.94kg)

Weight of backrest: 11 lb (5kg)

Weight of battery hand controller: 670g

Duration of stroke (80 kg load): Up approx. 50sec, down approx. 35sec

Operating voltage: 13.2V DC

Maximum current consumption: 5.9A

Nominal Input: 13.2V DC

Motor noise with no load: approx. 50dB

(according to DIN 3746)

Medical equipment type B

Class Protection: IP 66

Duty cycle: Max. 5%, Max. 3min./hour

Battery: 13.2V 1300mAh(Ni-MH)

Battery Charger

Input : 240V AC/50Hz, 230V AC/60Hz, 110V AC/60Hz

Output : 18V DC 250mA/ 4.5VA

Weight : 0.3kg(UK 282g /EU 285g /USA 275g)

Charging time with flat battery : approx. 12h

ACCESSORIES

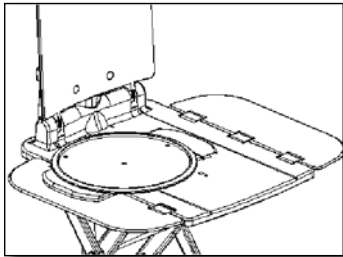

SWIVEL AND SLIDE UNIT

The AQUAJOY transfer disk will assist you to get on and off your bathlift easily and safely. It is ideal for people who have problems shuffling on and off the bathlift and allows them to slide and turn into the middle of the bathlift seat.

HEADREST

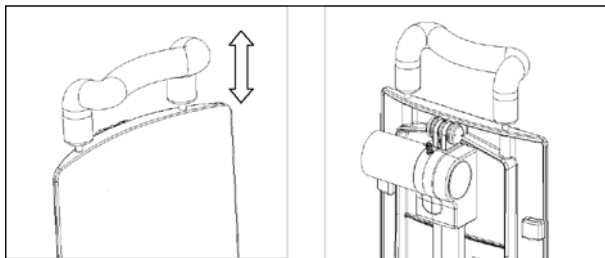

The AQUAJOY Headrest provides extra support and comfort while bathing.

POMMEL (FOR CHILDREN AND ADULTS)

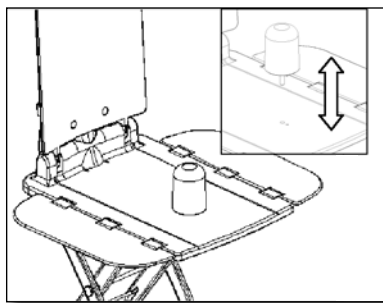

TO FIT THE POMMEL

Place the pommel prongs into the seat (base) locating holes and push down. The pommel will now sit in place.

TO REMOVE THE POMMEL

Simply pull upwards and the pommel will release.

TO FIT THE WING SUPPORTS ON THE BACKREST

Simply locate the guides on the wings into the location points on either side of the backrest.

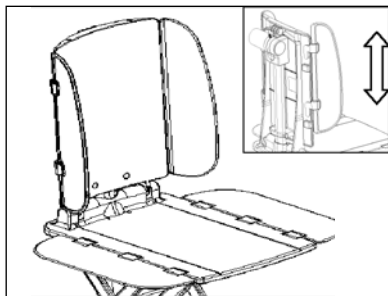

TO REMOVE THE WING SUPPORTS ON THE BACKREST

Simply pull upwards from the location points and the wing supports will release.

TO FIT THE CHEST & LAP HARNESS

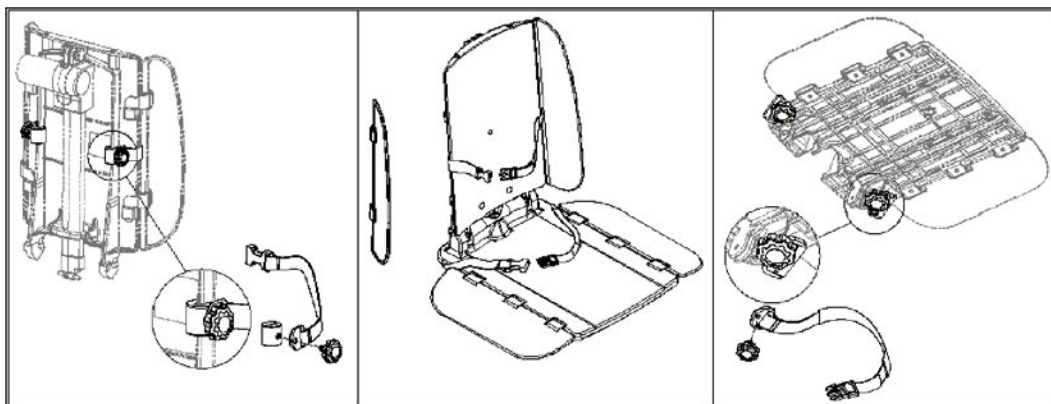

The chest harness-fixing bracket should be attached to the back of the backrest. It is adjustable by sliding the bracket up and down the backrest so that the belt can be positioned at the most suitable height for the user. The harness is secured by screwing the knob into the fixing bracket as shown in the attached diagram. (The short part of the two-piece chest harness should be attached to the side where the user is transferring for easy, quick release). The chest harness size is adjustable from the side by pulling the material through the buckle (as with a belt). To secure the user, simply insert the chest harness clip into the buckle.

The lap harness should be attached to the rear underside of the seat base. (The short part of the two-piece lap harness should be attached to the side where the user is transferring for easy, quick release). The harness is secured by screwing the knob into the boss insert as shown in the attached diagram. The lap harness size is adjustable from the side by pulling the material through the buckle (as with a belt). To secure the user, simply insert the lap harness clip into the buckle.

Avertissements / Warnings In French

- L'AQUAJROY SIÈGE ÉLÉVATEUR peut supporter un poids maximal de 170 kg (375 livres).
- L'AQUAJROY SIÈGE ÉLÉVATEUR est uniquement destiné à aider une personne à entrer et à sortir d'une baignoire.
- Avant de prendre un bain, faites un essai afin de vous familiariser avec le fonctionnement du siège élévateur.
- Si cela s'avère nécessaire, utilisez le siège élévateur sous la surveillance d'un membre de votre famille ou d'un aide-soignant.
- Vérifiez toujours la température de l'eau avant de prendre un bain.
- Ne placez jamais vos mains entre le socle et le siège (risque de coincement dans le mécanisme d'élévation _ ciseaux).
- Avant toute utilisation, vérifiez toujours qu'aucun obstacle ne puisse entraver le mécanisme.
- Installez l'AQUAJROY SIÈGE ÉLÉVATEUR à l'extrémité opposée à la robinetterie.
- Lors de l'installation du siège élévateur, vérifiez toujours que les rainures du dossier sont bien _ plat sur la base du siège.
- Ne placez aucune housse avant que l'assemblage ne soit terminé.
- Si votre baignoire comporte des poignées, attachez les clapets latéraux (bandes en plastique blanc) aux poignées de la baignoire.
- Si les clapets latéraux sont bloqués sous la poignée de la baignoire, arrêtez et soulevez l'élévateur, baissez l'obstacle et remettez le siège en position haute.
- L'AQUAJROY SIÈGE ÉLÉVATEUR ne doit être utilisé que dans la baignoire afin d'aider une personne à entrer et à sortir de la baignoire. Le siège élévateur ne doit pas être utilisé comme aide ou plateforme d'élévation en dehors d'une baignoire.
- Le siège élévateur n'est pas un jouet. Les enfants ne doivent pas être autorisés à jouer avec.
- N'autorisez jamais des enfants à utiliser le siège élévateur sans surveillance.
- Débranchez toujours la commande manuelle lorsque le dossier est replié.

Avertissements / Warnings In French

Avertissements EMI / RFI

Le siège élévateur peut être sujet _ des interférences électromagnétiques (EMI) et à des interférences de fréquence radio (RFI). N'utilisez pas à moins de 3 mètres (10 pieds) du siège élévateur les articles suivants : téléphones portables, talkie-walkies, émetteurs radio pour opérateurs radio amateurs, connexion informatique sans fil, objets dégageant des micro-ondes, pagers.

BATTERIE ET CHARGEUR

La commande manuelle sur batterie ne doit pas être jetée dans le feu ou conservée à proximité d'un feu. Débarrassez-vous des anciennes commandes manuelles de manière appropriée.

N'ouvrez pas la commande manuelle sur batterie.

Veillez à recharger la commande manuelle sur batterie dès qu'elle perd de sa puissance.

Utilisez uniquement l'AQUAJJOY SIÈGE ÉLÉVATEUR avec la commande manuelle sur batterie fournie.

Utilisez uniquement le chargeur de batterie fourni pour recharger la commande manuelle sur batterie.

Ne rechargez pas la commande manuelle sur batterie dans la salle de bain.

Manufacturer's Contact Information

**Careline Corp.
475-31, Bangbae-Dong,
Socho-ku, Seoul
Republic of Korea
Tel:+82 2 3487 4300**

U.S. Customer Service

**Harmar Access, LLC
2075 47th Street
Sarasota, FL 34234
Phone: (800) 833-0478
Fax: (866) 234-5680
customerservice@harmar.com**

Intentionally left blank.