

PRO-FORM[®]

ZR³

Model No. PFEX03409.0

Serial No. _____

Write the serial number in the space above for future reference.

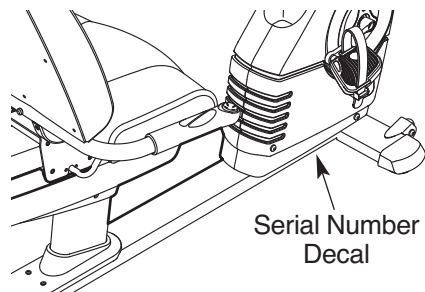

USER'S MANUAL

QUESTIONS?

If you have questions, or if parts are damaged or missing, **DO NOT CONTACT THE STORE**; please contact Customer Care.

IMPORTANT: Please register this product (see the limited warranty on the back cover of this manual) before contacting Customer Care.

CALL TOLL-FREE:

1-888-533-1333

Mon.–Fri. 6 a.m.–6 p.m. MT

Sat. 8 a.m.–4 p.m. MT

ON THE WEB:

www.proformservice.com

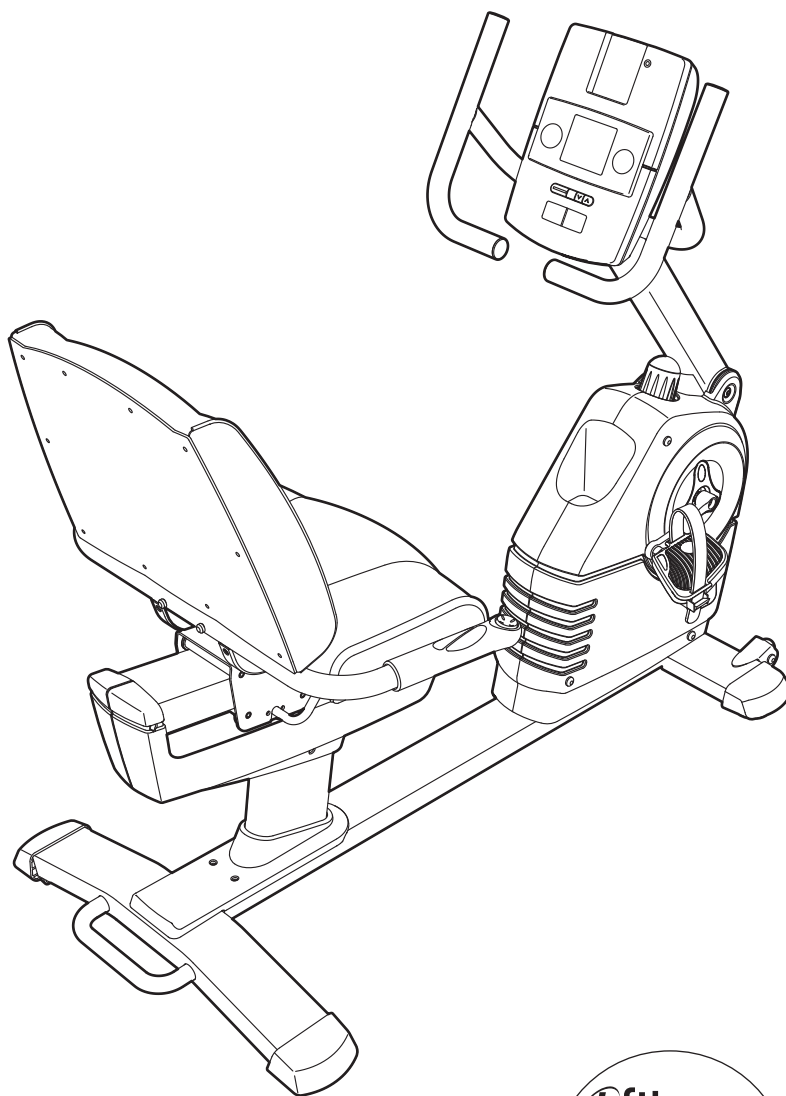

CAUTION

Read all precautions and instructions in this manual before using this equipment. Keep this manual for future reference.

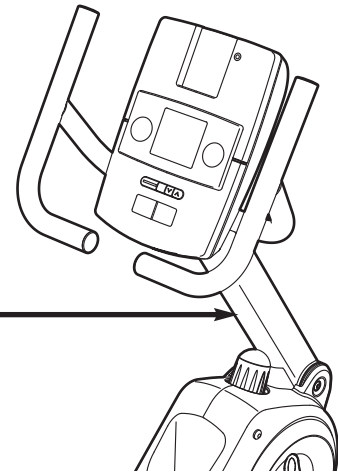
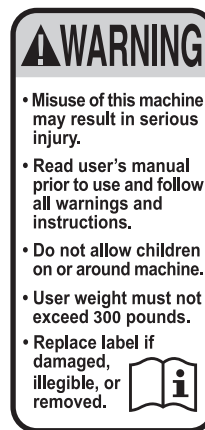

TABLE OF CONTENTS

WARNING DECAL PLACEMENT2
IMPORTANT PRECAUTIONS3
BEFORE YOU BEGIN4
ASSEMBLY5
HOW TO USE THE EXERCISE CYCLE12
MAINTENANCE AND TROUBLESHOOTING23
EXERCISE GUIDELINES24
PART LIST25
EXPLODED DRAWING26
ORDERING REPLACEMENT PARTSBack Cover
LIMITED WARRANTYBack Cover

WARNING DECAL PLACEMENT

This drawing shows the location(s) of the warning decal(s). **If a decal is missing or illegible, see the front cover of this manual and request a free replacement decal. Apply the decal in the location shown.** Note: The decal(s) may not be shown at actual size.



IMPORTANT PRECAUTIONS

⚠ WARNING: To reduce the risk of serious injury, read all important precautions and instructions in this manual and all warnings on your exercise cycle before using your exercise cycle. ICON assumes no responsibility for personal injury or property damage sustained by or through the use of this product.

1. Before beginning any exercise program, consult your physician. This is especially important for persons over age 35 or persons with pre-existing health problems.
2. Use the exercise cycle only as described in this manual.
3. It is the responsibility of the owner to ensure that all users of the exercise cycle are adequately informed of all precautions.
4. The exercise cycle is intended for home use only. Do not use the exercise cycle in a commercial, rental, or institutional setting.
5. Keep your exercise cycle indoors, away from moisture and dust. Place your exercise cycle on a level surface, with a mat beneath it to protect the floor or carpet. Make sure that there is at least 2 ft. (0.6 m) of clearance around your exercise cycle.
6. Inspect and properly tighten all parts regularly. Replace any worn parts immediately.
7. Keep children under age 12 and pets away from the exercise cycle at all times.
8. Wear appropriate clothes while exercising; do not wear loose clothes that could become caught on the exercise cycle. Always wear athletic shoes for foot protection.
9. The exercise cycle should not be used by persons weighing more than 300 lbs. (136 kg).
10. The pulse sensor is not a medical device. Various factors, including the user's movement, may affect the accuracy of heart rate readings. The pulse sensor is intended only as an exercise aid in determining heart rate trends in general.
11. Always keep your back straight while using the exercise cycle; do not arch your back.
12. Over exercising may result in serious injury or death. If you feel faint or if you experience pain while exercising, stop immediately and cool down.

BEFORE YOU BEGIN

Thank you for selecting the revolutionary PROFORM® ZR3 exercise cycle. Cycling is an effective exercise for increasing cardiovascular fitness, building endurance, and toning the body. The ZR3 exercise cycle provides an impressive selection of features designed to make your workouts at home more effective and enjoyable.

For your benefit, read this manual carefully before you use the exercise cycle. If you have questions

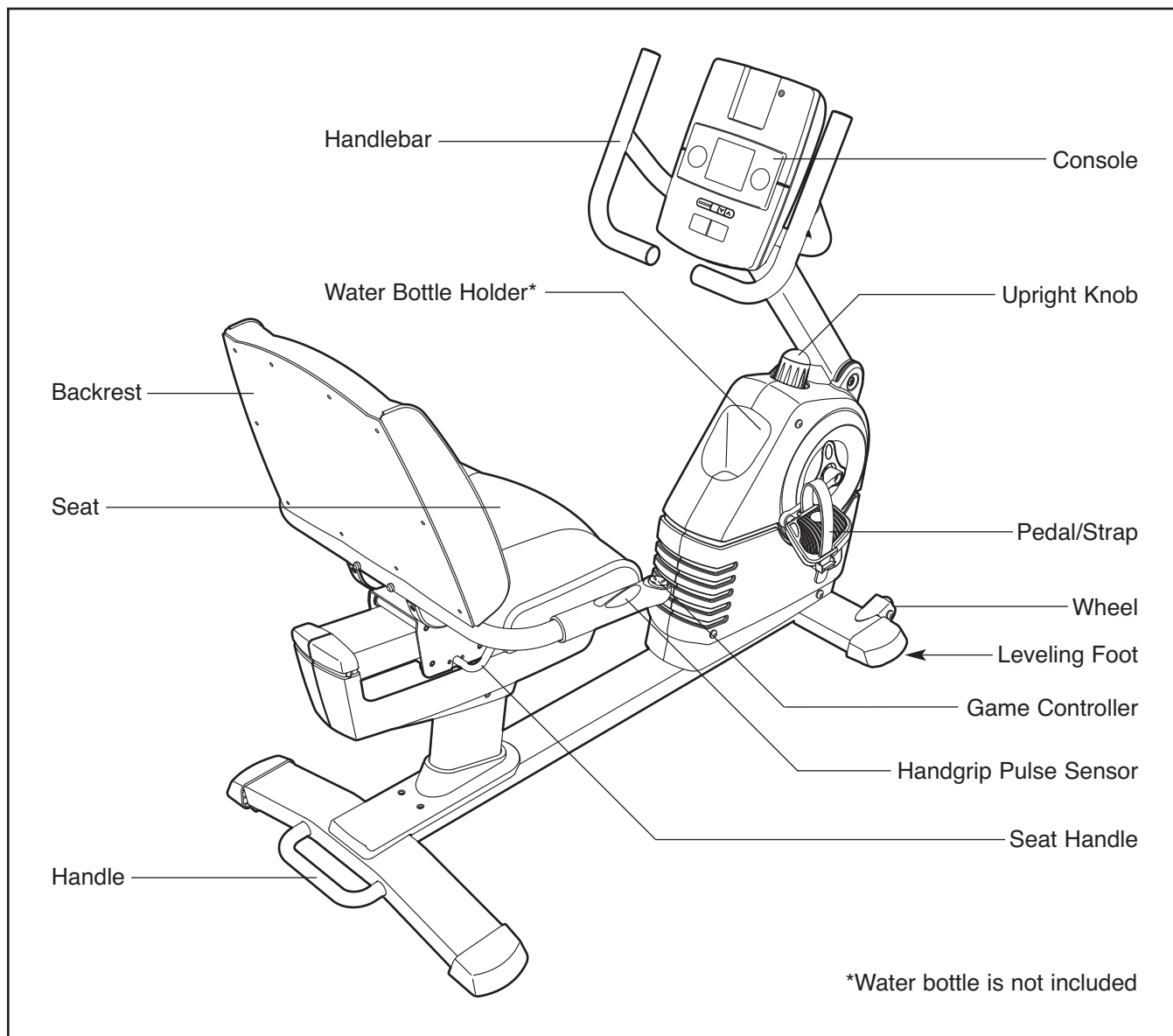

after reading this manual, please see the front cover of this manual. To help us assist you, note the product model number and serial number before contacting us. The model number and the location of the serial number decal are shown on the front cover of this manual.

Before reading further, please familiarize yourself with the parts that are labeled in the drawing below.

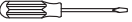

ASSEMBLY

Assembly requires two persons. Place all parts of the exercise cycle in a cleared area and remove the packing materials. Do not dispose of the packing materials until assembly is completed.

In addition to the included tool(s), assembly requires a Phillips screwdriver , **an adjustable wrench** , **and a rubber mallet** .

As you assemble the exercise cycle, use the drawings below to identify small parts. The number in parentheses below each drawing is the key number of the part, from the PART LIST near the end of this manual. The number following the parentheses is the quantity needed for assembly. **Note: If a part is not in the hardware kit, check to see if it has been preassembled.**

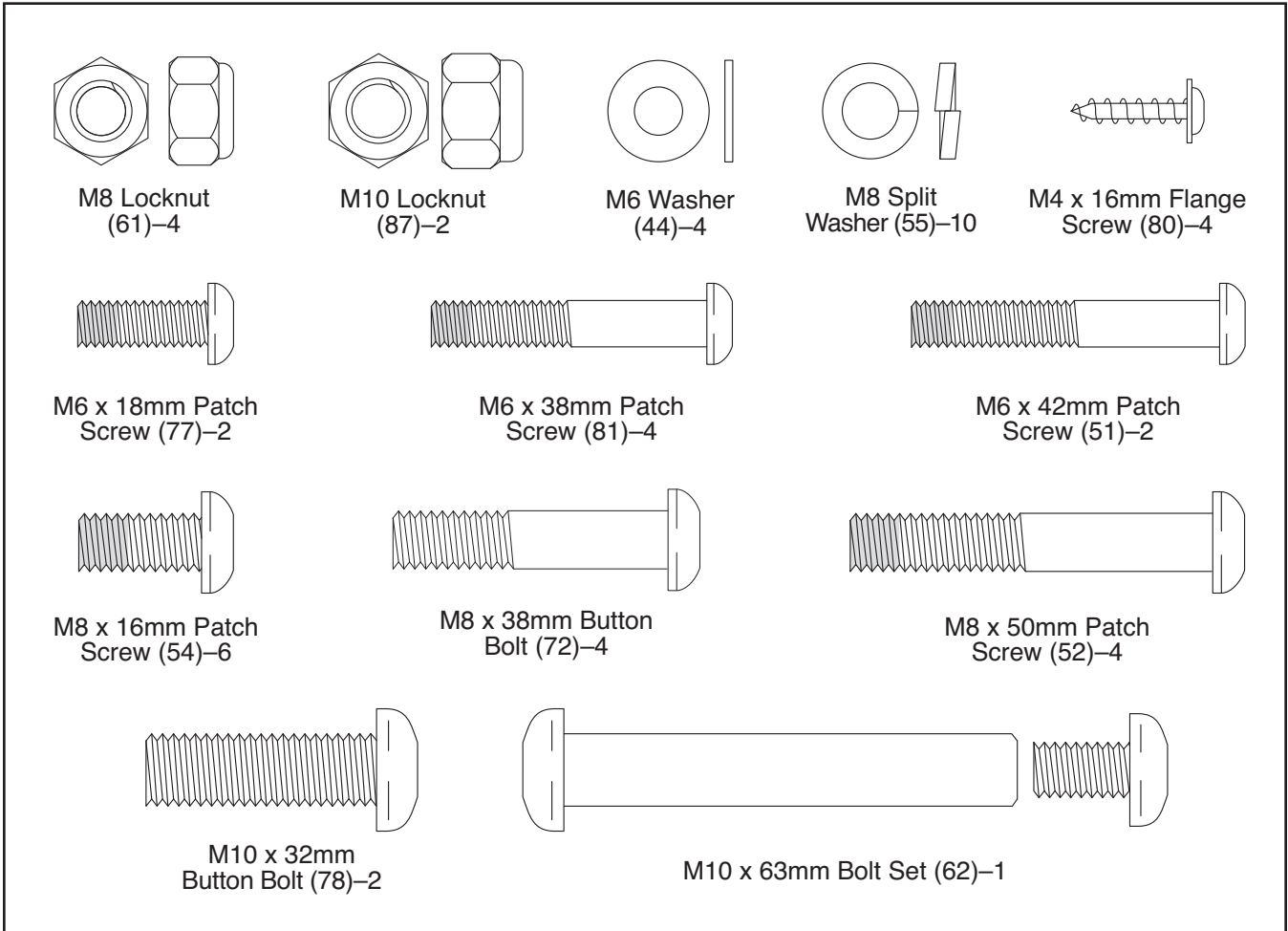

1.

To make assembly easier, read the information on page 5 before you begin.

Orient the Right Front Stabilizer (40) as shown.

Attach the Right Front Stabilizer (40) to the right side of the Frame (1) with three M8 x 16mm Patch Screws (54) and three M8 Split Washers (55).

Attach the Left Front Stabilizer (not shown) to the left side of the Frame (1) in the same way.

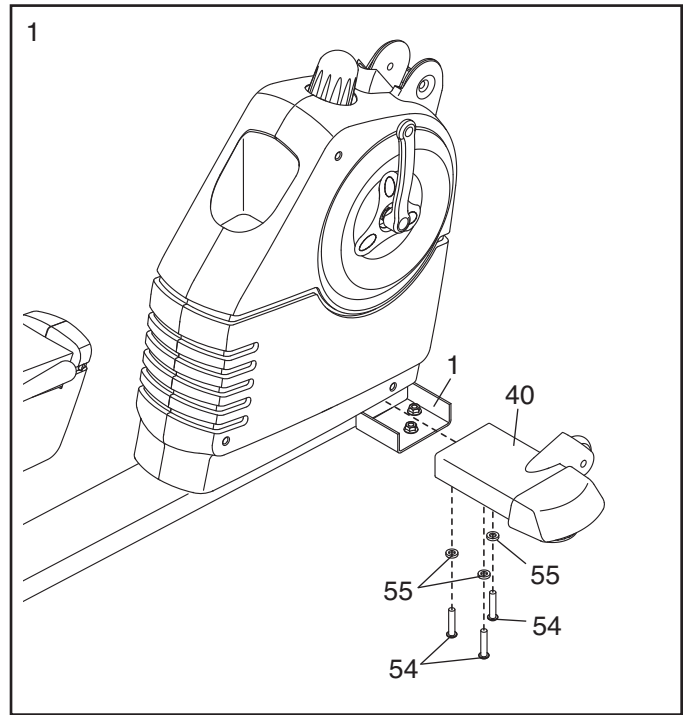

2. While another person lifts the rear of the Frame (1), attach the Rear Stabilizer (16) to the Frame with four M8 x 50mm Patch Screws (52) and four M8 Split Washers (55).

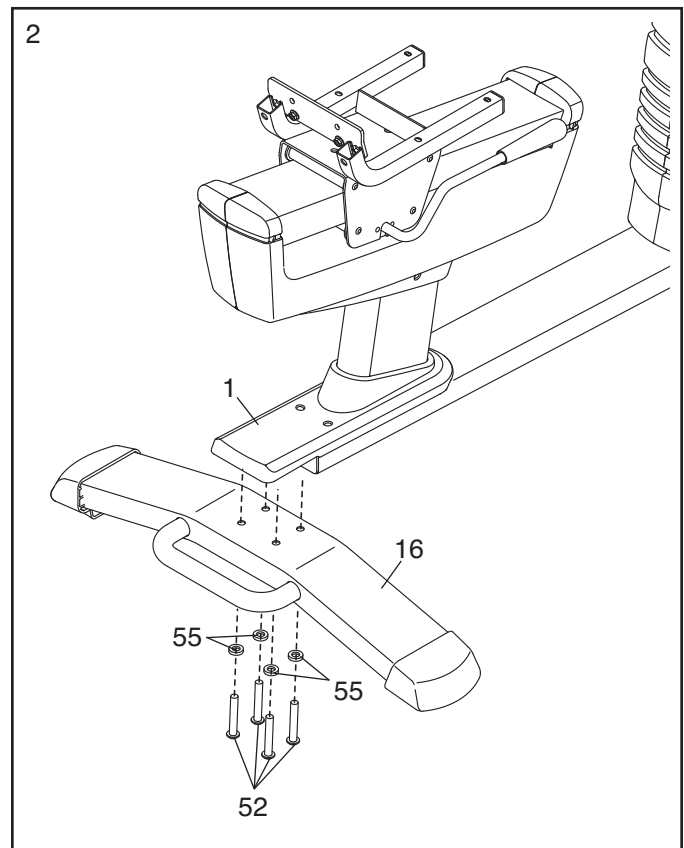

3. While another person holds the Upright (2) near the Frame (1), locate the wire tie inside the Upright.

See the inset drawing. Tie the lower end of the wire tie to the ends of the Game/Pulse and Main Wire Harnesses (42, 43). Then, pull the other end of the wire tie upward out of the top of the Upright (2).

Tip: Do not pinch the Wire Harnesses (42, 43). Attach the Upright (2) to the Frame (1) with an M10 x 63mm Bolt Set (62).

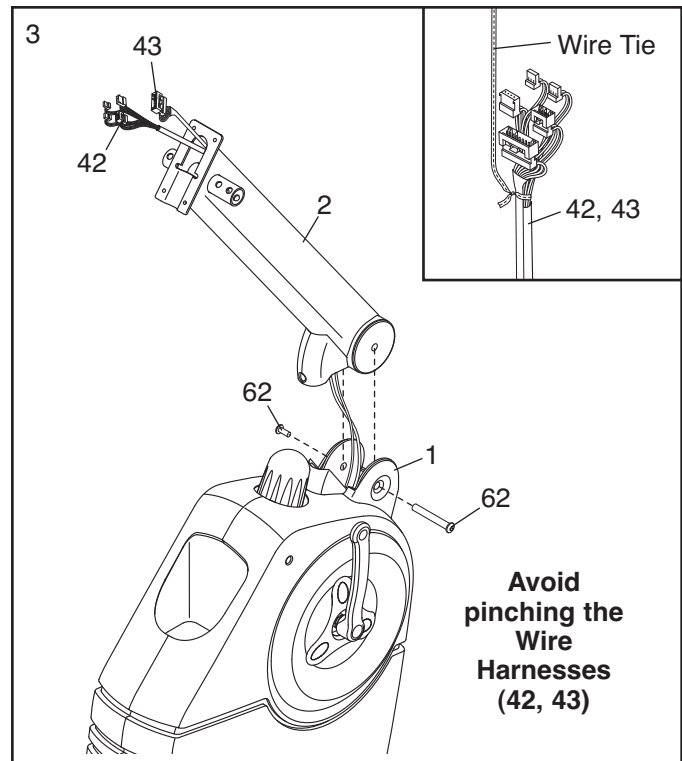

4. Identify the Right and Left Handlebars (59, 60), which are marked with "Right" and "Left" stickers.

Orient the Right and Left Handlebars (59, 60) so that the hexagonal holes are in the indicated locations.

Attach each Handlebar (59, 60) to the Upright (2) with two M8 x 38mm Button Bolts (72) and two M8 Locknuts (61). **Make sure that the Locknuts are in the hexagonal holes.**

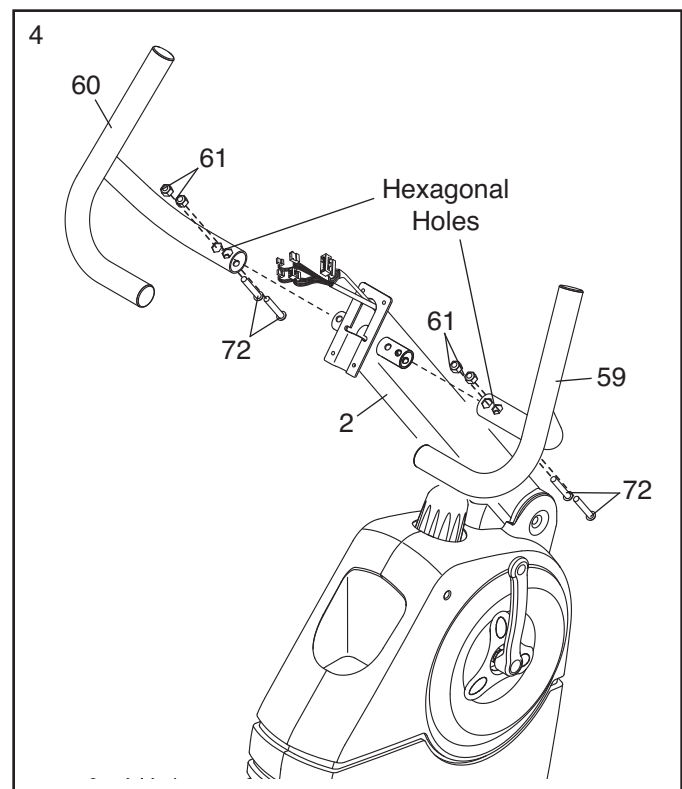

5. The Console (4) can use four D batteries (not included); alkaline batteries are recommended. **IMPORTANT: If the Console has been exposed to cold temperatures, allow it to warm to room temperature before inserting batteries. Otherwise, you may damage the console displays or other electronic components.** Remove the indicated screw, remove the battery cover, insert the batteries into the battery compartment, and then reattach the battery cover. **Make sure to orient the batteries as shown by the diagrams inside the battery compartment.**

To purchase an optional AC adapter, contact the store where you purchased this product or call the telephone number on the front cover of this manual. To avoid damaging the console, use only a manufacturer-supplied AC adapter. Plug one end of the AC adapter into the jack on the console; plug the other end into an outlet installed in accordance with all local codes and ordinances.

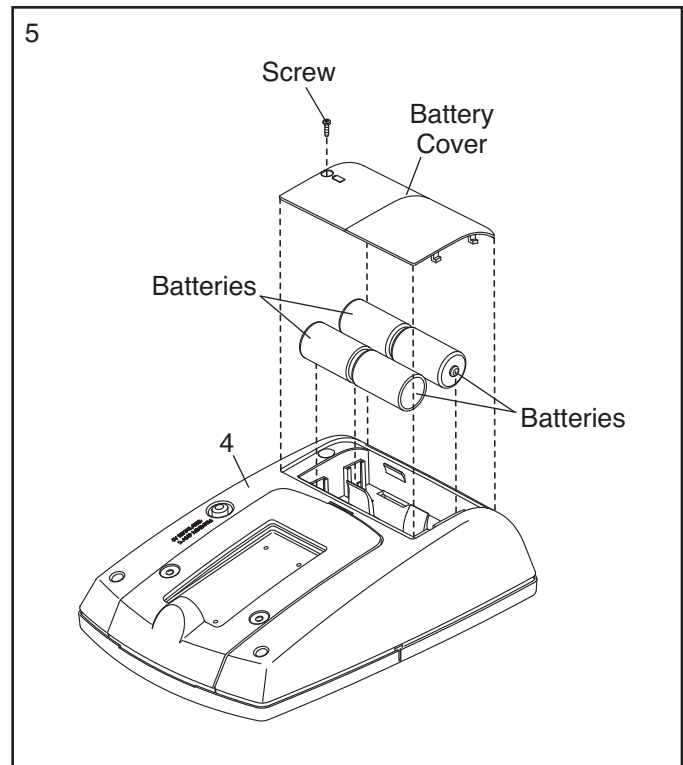

6. While another person holds the Console (4) near the Upright (2), connect the console wire harnesses to the Game/Pulse and Main Wire Harnesses (42, 43); **make sure to connect the console wire that has a tag to the game wire that has a tag.** Insert the excess wire downward into the Upright.

Tip: Do not pinch the Wire Harnesses (42, 43). Attach the Console (4) to the Upright (2) with four M4 x 16mm Flange Screws (80).

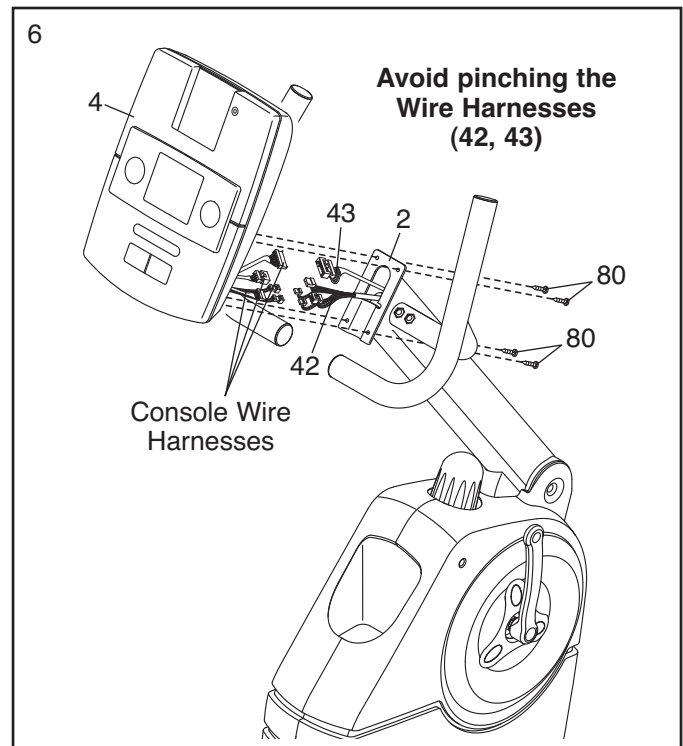

7. Identify and orient the Seat Handlebar (11) so that the Controllers face upward. **Make sure that the hexagonal holes are in the indicated locations.**

Tip: Do not pinch the Game/Pulse Wire (58). Attach the Seat Handlebar (11) to the Seat Carriage (3) with two M10 x 32mm Button Bolts (78) and two M10 Locknuts (87). **Do not fully tighten the Locknuts yet.**

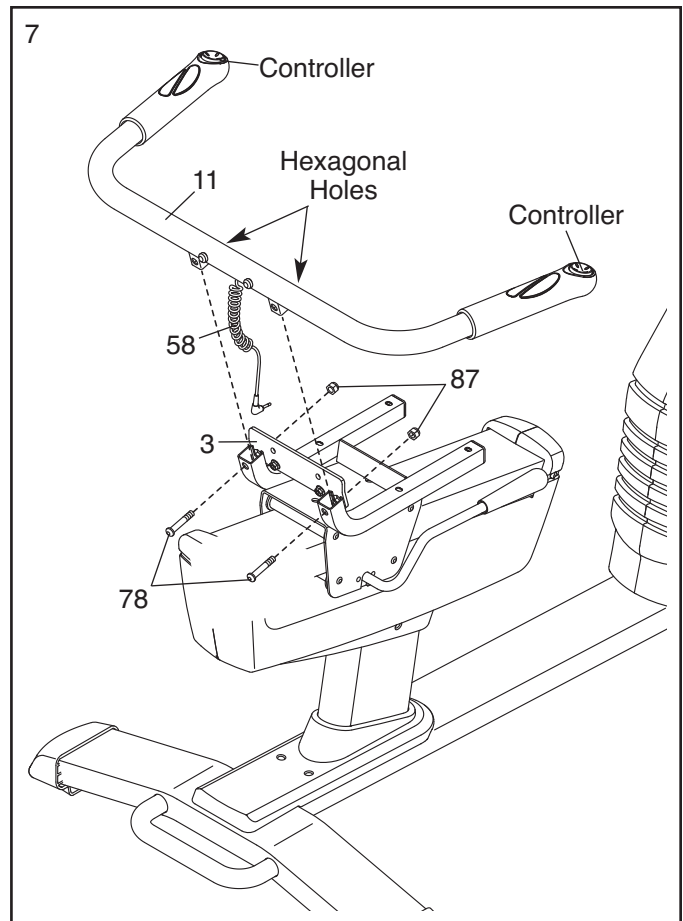

8. **Tip: Do not pinch the Game/Pulse Wire (58).** Attach the Backrest (8) to the Seat Carriage (3) with two M6 x 18mm Patch Screws (77) and two M6 x 42mm Patch Screws (51).

Tip: First tighten the M6 x 18mm Patch Screws (77), and then tighten the M6 x 42mm Patch Screws (51).

See step 7. Tighten the M10 Locknuts (87).

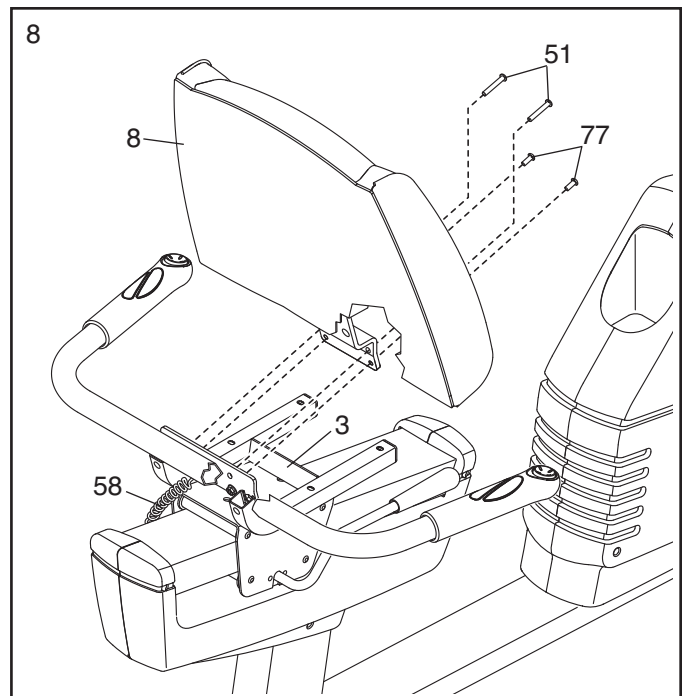

9. Attach the Seat (9) to the Seat Carriage (3) with four M6 x 38mm Patch Screws (81) and four M6 Washers (44) (only two of each are shown).
Note: The Patch Screws and Washers may be preattached to the underside of the Seat.

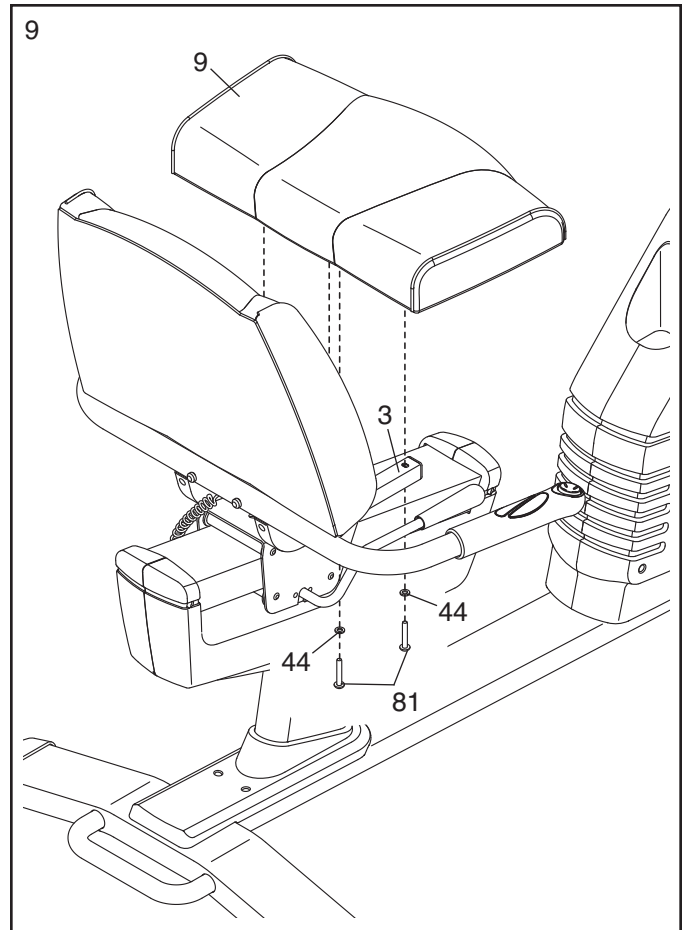

10. Plug the Game/Pulse Wire (58) into the Game/Pulse Receptacle (79) located in the Left Shield (26).

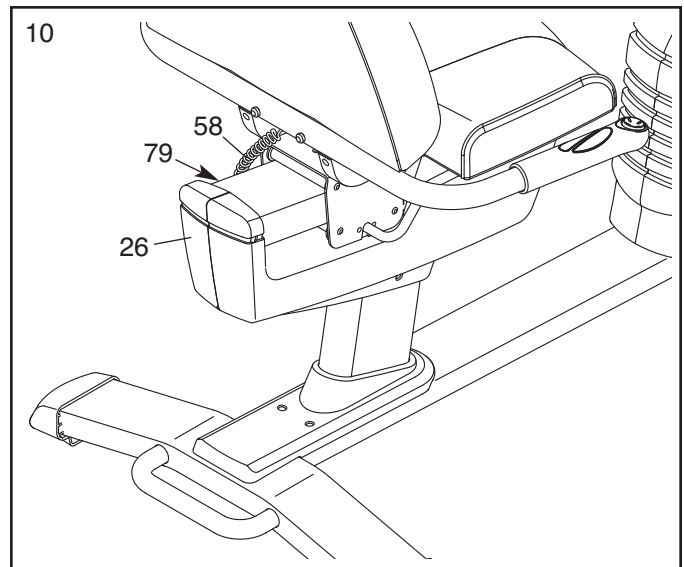

11. Identify the Right Pedal (21), which is marked with an "R." Using an adjustable wrench, **firmly tighten** the Right Pedal *clockwise* into the Right Crank (23). Tighten the Left Pedal (not shown) *counterclockwise* into the Left Crank (not shown). **IMPORTANT: Tighten both Pedals as firmly as possible. After using the exercise cycle for one week, retighten the Pedals.**

To loosen the strap on the Right Pedal (21), press the indicated tab and pull the strap upward. To tighten the strap, simply pull the end of the strap downward. **Adjust the strap on the Left Pedal (not shown) in the same way.**

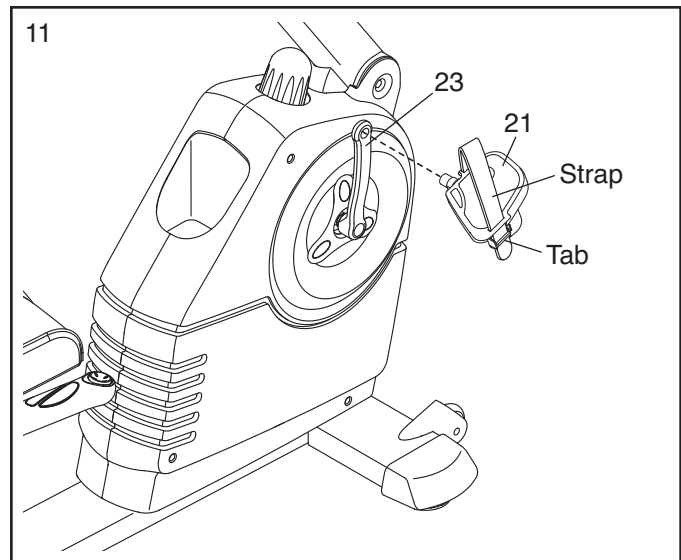

12. **Make sure that all parts are properly tightened before you use the exercise cycle.** Note: After assembly is completed, some extra parts may be left over. Place a mat beneath the exercise cycle to protect the floor.

HOW TO USE THE EXERCISE CYCLE

HOW TO ADJUST THE PEDAL STRAPS

To loosen the strap on a pedal, press the indicated tab and pull the strap upward. To tighten the strap, simply pull the end of the strap downward.

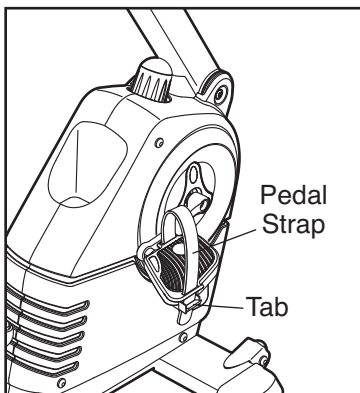

HOW TO ADJUST THE UPRIGHT

The upright can be adjusted to the position that is the most comfortable for you. To adjust the upright, first raise the upright so that it is not resting on the upright knob. Next, turn the upright knob clockwise or counterclockwise to raise or lower the upright. Then, rest the upright on the upright knob.

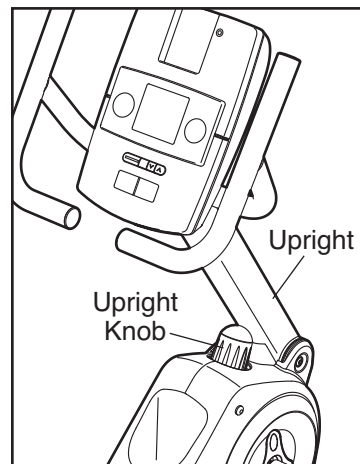

HOW TO ADJUST THE SEAT

The seat can be adjusted forward or backward to the position that is the most comfortable for you. To adjust the seat, push downward on the seat handle, slide the seat to the desired position, and then pull upward on the seat handle to lock the seat in place.

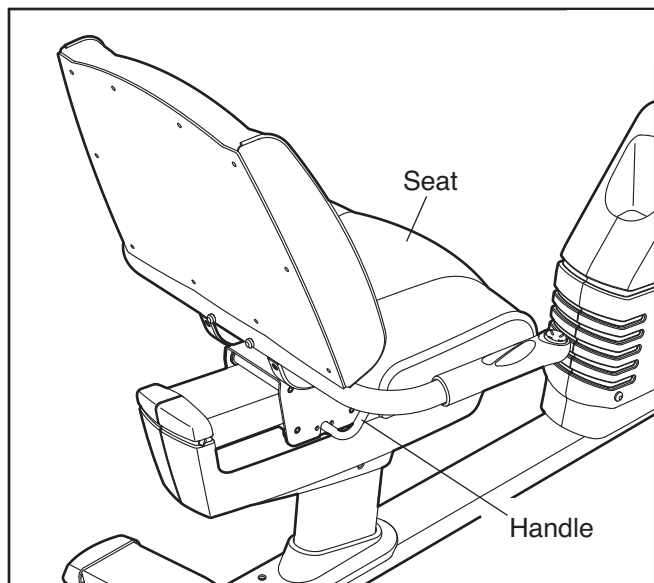

HOW TO MOVE THE EXERCISE CYCLE

To move the exercise cycle, hold the handle on the rear stabilizer and carefully lift it until the exercise cycle can be moved on the front wheels. Carefully move the exercise cycle to the desired location and then lower it.

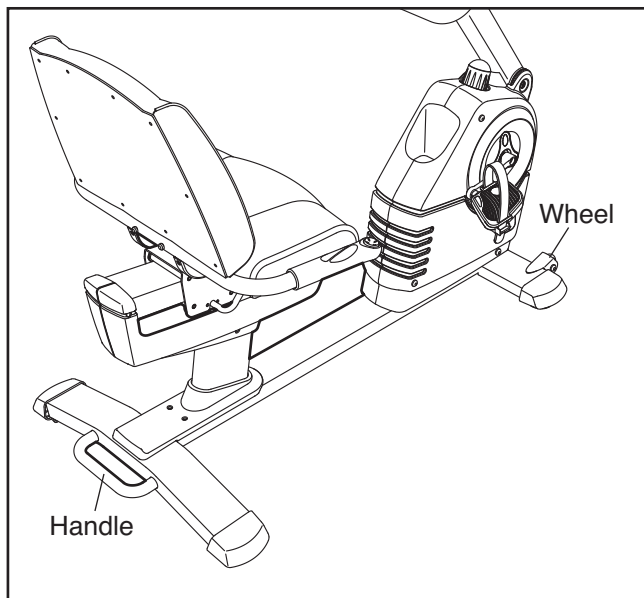

HOW TO LEVEL THE EXERCISE CYCLE

If the exercise cycle rocks slightly on your floor during use, turn one or both of the leveling feet under the front stabilizers until the rocking motion is eliminated.

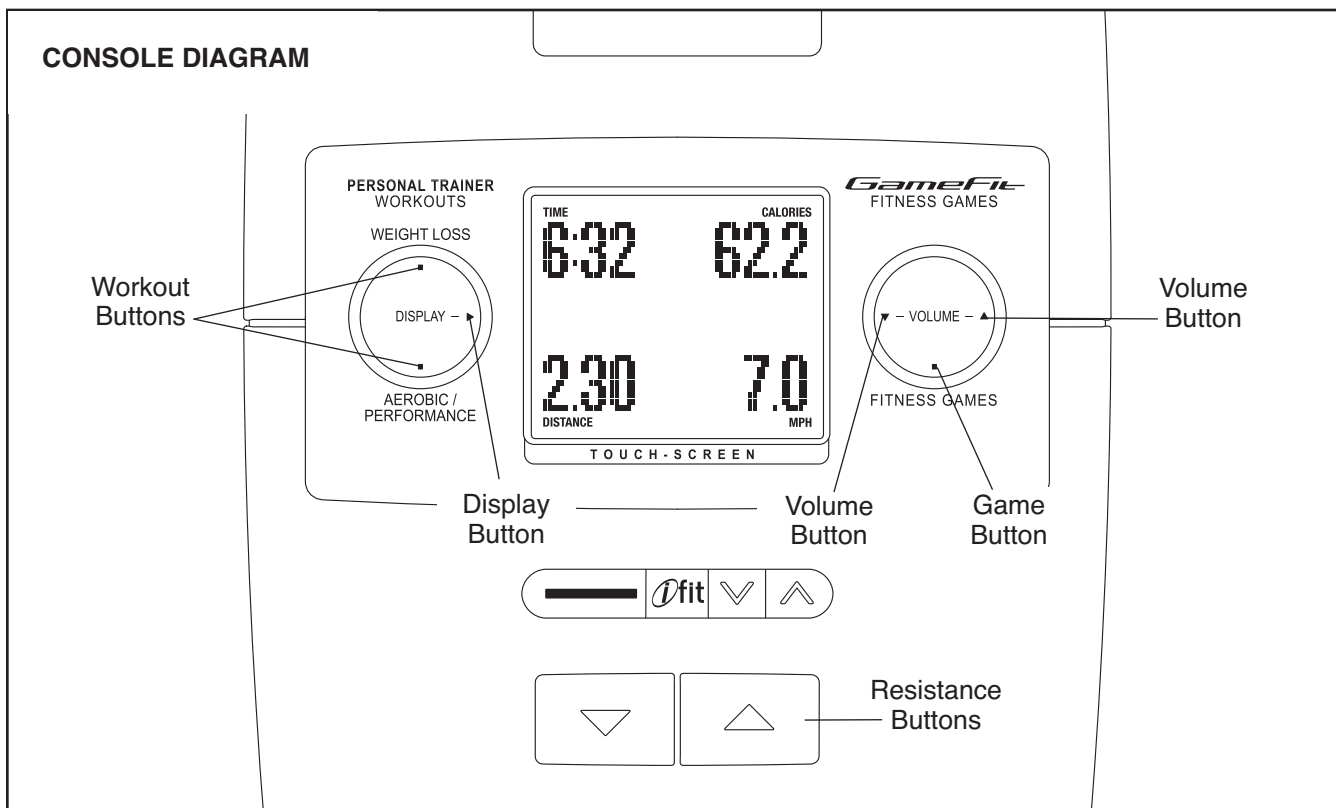

FEATURES OF THE CONSOLE

This revolutionary console offers an array of features designed to make your workouts more effective and enjoyable.

When you use the manual mode of the console, you can change the resistance of the pedals with the touch of a button. While you exercise, the console will display continuous exercise feedback. You can even measure your heart rate using the handgrip pulse sensor.

The console offers twenty preset workouts. Each workout automatically changes the resistance of the pedals and prompts you to vary your pedaling speed as it guides you through an effective workout.

The console also features four motivational interactive games. Using the dual game controllers, play the challenging Fat Blocker™ game or the fast-paced Calorie Destroyer™ game during your workouts—the harder you exercise, the greater your advantage! Or, use your wits and the interactive touch screen to win credits while playing the classic card game of Blackjack or Texas Hold 'Em.

The console also features the iFit interactive workout system, which enables the console to accept iFit cards containing workouts designed to help you achieve specific fitness goals. For example, lose unwanted pounds with the 8-week Weight Loss workout. iFit workouts control the resistance of the pedals while the voice of a personal trainer coaches you through your workouts. iFit cards are available separately. **To purchase iFit cards, go to www.iFit.com or see the front cover of this manual. iFit cards are also available at select stores.**

You can even connect your MP3 player or CD player to the console's sound system and listen to your favorite workout music or audio books while you exercise.

To use the manual mode, see page 14. To use a preset workout, see page 16. To play the Fat Blocker game, see page 17. To play the Calorie Destroyer game, see page 18. To play the Blackjack game, see page 19. To play the Texas Hold 'Em game, see page 20. To use an iFit workout, see page 21. To use the sound system, see page 21. To change the console settings, see page 22.

Note: Before using the console, make sure that batteries are installed (see assembly step 5 on page 8). If there is a sheet of clear plastic on the display, remove the plastic.

HOW TO USE THE MANUAL MODE

1. **Begin pedaling or press any button on the console to turn on the console.**

When you turn on the console, the display will light. The console will then be ready for use.

2. **Select the manual mode.**

Each time you turn on the console, the manual mode will be selected.

If you have selected a workout, press any of the Workouts buttons or the Fitness Games button (see the drawing on page 13) repeatedly until zeroes appear in the display.

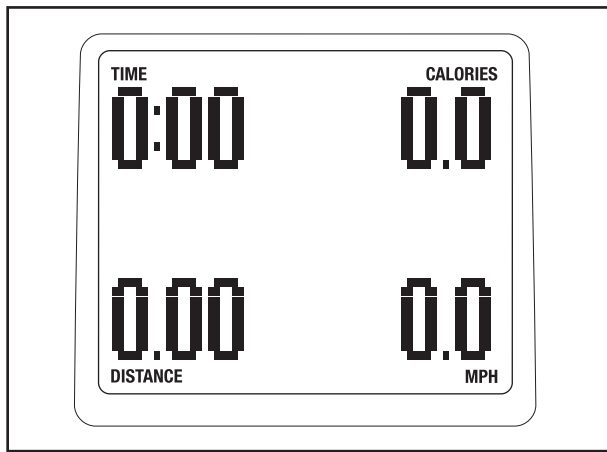

3. **Change the resistance of the pedals as desired.**

As you pedal, change the resistance of the pedals by pressing the resistance increase and decrease buttons

(see the drawing on page 13) repeatedly. Note: After you press the buttons, it will take a moment for the pedals to reach the selected resistance level.



4. **Follow your progress with the display.**

The console offers several display modes. The display mode that you select will determine which workout information is shown. Press the Display button (see the drawing on page 13) repeatedly to select the desired display mode.

The display can show the following workout information:

Time—When the manual mode is selected, this display will show the elapsed time. When a workout is selected, the display will show the time remaining in the workout instead of the elapsed time.

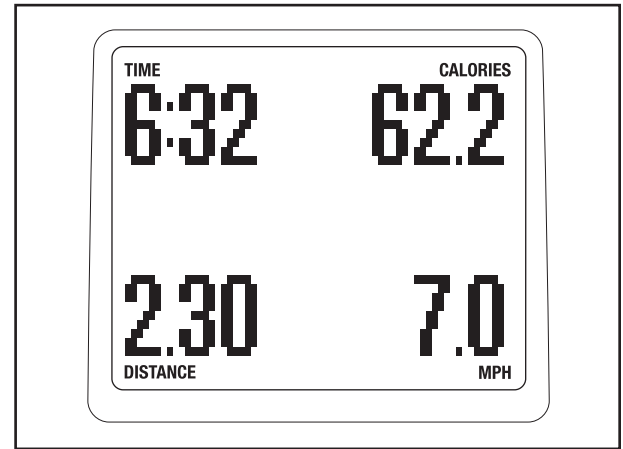

Speed—This display will show your pedaling speed, in miles per hour (MPH) or kilometers per hour (KM/H).

Distance—This display will show the distance you have pedaled, in miles or kilometers.

Calories—This display will show the approximate number of calories you have burned.

Watts—This display will show your approximate power output in watts.

Pulse—This display will show your heart rate when you use the handgrip pulse sensor (see step 5 below).

Resistance—This display will show the resistance level of the pedals for a few seconds each time the resistance level changes.

Profile—When a workout is selected, this display will show a profile of the resistance settings for the workout.

Display Settings—The console offers a display settings mode that can be entered when the words HOLD DISPLAY FOR SETTINGS appear in the display. To change the display settings, see HOW TO CHANGE THE CONSOLE SETTINGS on page 22.

Change the volume level of the console by pressing the Volume increase and decrease buttons.

Note: The console can show pedaling speed and distance in either miles or kilometers. The letters MPH or KM/H will appear in the display to show which unit of measurement is selected. To change the unit of measurement, see step 3 of HOW TO CHANGE THE CONSOLE SETTINGS on page 22.

5. Measure your heart rate if desired.

If there are sheets of clear plastic on the metal contacts on the handgrip pulse sensor, remove the plastic. To measure your heart rate, hold the handgrip pulse sensor with your palms resting against the metal contacts. **Avoid moving your hands or gripping the contacts tightly.**

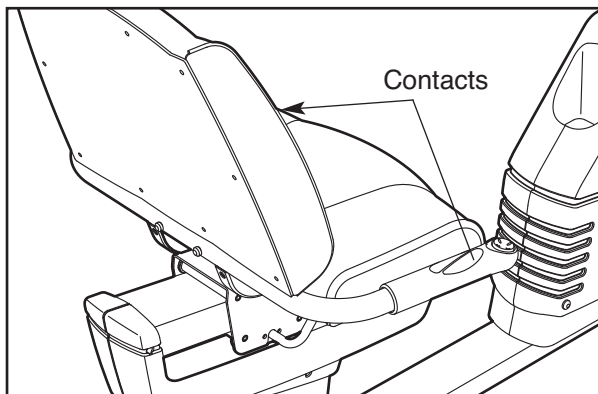

When your pulse is detected, dashes will appear in the display, and then your heart rate will be shown. For the most accurate heart rate reading, hold the contacts for at least 15 seconds. Note: If you continue to hold the handgrip pulse sensor, the display will show your heart rate for up to 30 seconds.

If the display does not show your heart rate, make sure that your hands are positioned as described. Be careful not to move your hands excessively or to squeeze the metal contacts tightly. For optimal performance, clean the metal contacts using a soft cloth; **never use alcohol, abrasives, or chemicals to clean the contacts.**

6. When you are finished exercising, the console will turn off automatically.

If the pedals do not move for several seconds, a tone will sound, the console will pause, and the time will flash in the display. To resume your workout, simply resume pedaling.

If the pedals do not move for several minutes and the buttons are not pressed, the console will turn off and the display will be reset.

HOW TO USE A PRESET WORKOUT

1. **Begin pedaling or press any button on the console to turn on the console.**

When you turn on the console, the display will light. The console will then be ready for use.

2. **Select a preset workout.**

To select a preset workout, press the Weight Loss or the Aerobic/Performance button repeatedly until the profile of the desired workout appears in the display.

The workout time and a profile of the resistance levels for the workout will appear in the display.

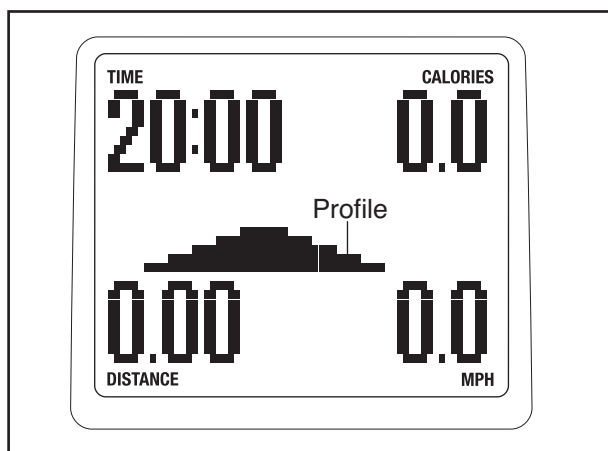

3. **Begin pedaling to start the workout.**

Each workout is divided into 20 or 30 one-minute segments. One resistance level and one target speed are programmed for each segment. Note: The same resistance level and/or target speed may be programmed for consecutive segments.

During the workout, the workout profile will show your progress. The flashing segment of the profile represents the current segment of the workout. The height of the flashing segment indicates the resistance level for the current segment.

At the end of each segment of the workout, a series of tones will sound and the next segment of the profile will begin to flash. The resistance level and the target speed will also appear in the display.

If a different resistance level and/or target speed is programmed for the next segment, the resistance level and/or the target speed will flash in the display for a few seconds to alert you. The resistance of the pedals will then change.

As you exercise, you will be prompted to keep your pedaling speed near the target speed for the current segment.

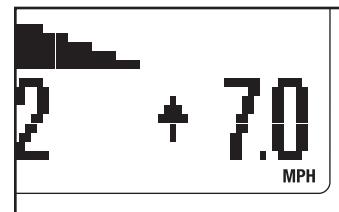

When an upward-pointing arrow appears in the display, increase your speed. When a downward-pointing arrow appears in the display, decrease your speed. When no arrows appear, maintain your current speed.

IMPORTANT: The target speed is intended only to provide motivation. Your actual speed may be slower than the target speed. Make sure to exercise at a speed that is comfortable for you.

If the resistance level for the current segment is too high or too low, you can manually override the setting by pressing the resistance buttons.

IMPORTANT: When the current segment of the workout ends, the pedals will automatically adjust to the resistance level for the next segment.

The workout will continue in this way until the last segment ends. To stop the workout at any time, stop pedaling. A tone will sound, the console will pause, and the time will begin to flash in the display. To restart the workout, simply resume pedaling.

4. **Follow your progress with the display.**

See step 4 on page 14.

5. **Measure your heart rate if desired.**

See step 5 on page 15.

6. **When you are finished exercising, the console will turn off automatically.**

See step 6 on page 15.

HOW TO PLAY THE FAT BLOCKER GAME

The Fat Blocker game requires quick thinking and fast reflexes. In addition to the console buttons, you will use the four-button game controllers on the handlebar to play the game. Follow the steps below to play the Fat Blocker game.

- 1. Begin pedaling or press any button on the console to turn on the console.**

When you turn on the console, the display will light. The console will then be ready for use.

- 2. Select the Fat Blocker game.**

To select the Fat Blocker game, press the Fitness Games button (see the drawing on page 13) repeatedly until the words FAT BLOCKER appear in the display .

- 3. Begin pedaling or press a button on either controller to start the game.**

When you start the Fat Blocker game, a game arena will appear in the center of the display.

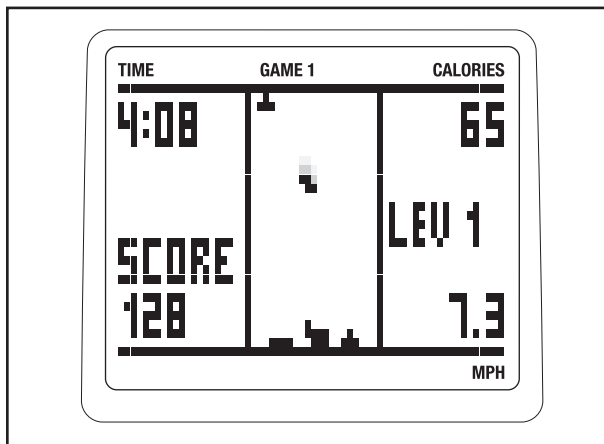

A block composed of four or five black squares will slowly move downward until it reaches the bottom of the arena. Another block will then move downward. Blocks come in eight different shapes. As each block falls, you can move it to the left or right using the left and right buttons on the left controller. In addition, you can rotate the block counterclockwise or clockwise using the left and right buttons on the right controller. Once you have positioned and oriented a block, you can speed its motion to the bottom of the arena, if desired, by pressing the down button on either controller.

Your goal is to maneuver the blocks so that they form a complete row of black squares across the entire arena. Each time you complete

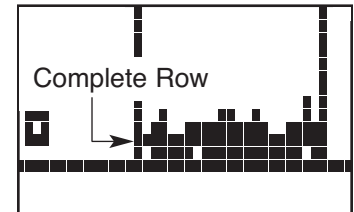

a row of black squares, the row will disappear, and all blocks above will move downward one row.

As you play, the blocks will fall faster and faster; however, your pedaling speed will affect the speed of the blocks—the faster you pedal, the more slowly the blocks will fall, giving you extra time to position and orient the blocks. The game will continue until any part of a stacked block reaches the top of the arena.

When the game ends, the display will show your final score and the level of play that you reached. The display will then show the four highest scores recorded since the scores were reset. If desired, press and hold down the right button on either controller to reset the scores. Note: If your score is one of the four highest, the display will prompt you to enter a name consisting of three letters or digits. While the line below the first letter is flashing, press the up and down buttons on either controller to select the desired letter or digit. Next, press the right button on either controller and select another letter or digit. Repeat this process to select a third letter or digit. Then, press the right button on either controller again. The display will then show the four highest scores recorded since the scores were reset.

- 4. Follow your progress with the display.**

While you exercise and play the Fat Blocker game, the corners of the display will show the elapsed time, the approximate number of calories you have burned, and your pedaling speed. In addition, the display will show your current score and the game level that you have reached.

To pause the game, press the Display button. To resume the game, press the Display button repeatedly until the words FAT BLOCKER appear at the top of the display, and then press a button on either controller.

- 5. When you are finished exercising, the console will turn off automatically.**

See step 6 on page 15.

HOW TO PLAY THE CALORIE DESTROYER GAME

The Calorie Destroyer game is a fast-paced game that pits you against a squadron of laser-firing drones. In addition to the console buttons, you will use the four-button game controllers on the handlebar to play the game. Follow the steps below to play the Calorie Destroyer game.

1. Begin pedaling or press any button on the console to turn on the console.

When you turn on the console, the display will light. The console will then be ready for use.

2. Select the Calorie Destroyer game.

To select the Calorie Destroyer game, press the Fitness Games button (see the drawing on page 13) repeatedly until the word DESTROYER appears in the display.

3. Press a button on either controller to start the game.

When you start the Calorie Destroyer game, a game arena will appear in the display. Three rows of drones will begin to move across the top of the arena, periodically firing their lasers downward. Each time the drones reach the left or right side of the arena, they will reverse direction and move downward.

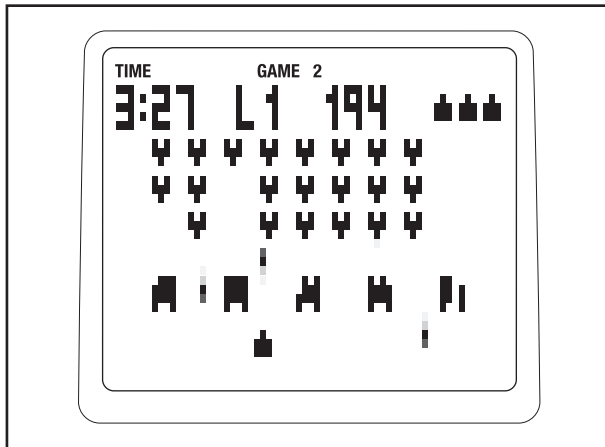

At the bottom of the arena is a laser blaster. You can fire the laser blaster at the drones by pressing the up button on either controller. In addition, while you are pedaling, you can move the laser blaster to the left or right using the left and right buttons on either controller. The faster you pedal, the faster the laser blaster will move.

Between the drones and the laser blaster are five shields. You can hide the laser blaster below a shield if desired. However, each time a shield is hit by a laser, a piece will be vaporized.

Your goal is to keep the laser blaster from being hit and to keep any drone from reaching the bottom of the arena. If the laser blaster is hit, it will be disabled and another laser blaster will appear in its place; there are a total of four laser blasters. If you vaporize the entire squadron of drones, a new squadron will appear.

As you play, the drones will move faster and faster. The game will continue until all four laser blasters are disabled or a drone reaches the bottom of the arena.

When the game ends, the display will show the level of play that you reached and your final score. The display will then show the four highest scores recorded since the scores were reset. If desired, press and hold down the right button on either controller to reset the scores. Note: If your score is one of the four highest, the display will prompt you to enter a name consisting of three letters or digits. While the line below the first letter is flashing, press the up and down buttons on either controller to select the desired letter or digit. Next, press the right button on either controller and select another letter or digit. Repeat this process to select a third letter or digit. Then, press the right button on either controller again. The display will then show the four highest scores recorded since the scores were reset.

4. Follow your progress with the display.

While you exercise and play the Calorie Destroyer game, the upper left corner of the display will show the elapsed time. In addition, the display will show the game level that you have reached and your current score.

To pause the game, press the Display button. To resume the game, press the Display button repeatedly until the word DESTROYER appears at the top of the display, and then press a button on either controller.

5. When you are finished exercising, the console will turn off automatically.

See step 6 on page 15.

HOW TO PLAY THE BLACKJACK GAME

Blackjack is a casino-style card game in which you compete against the dealer to win credits. Your goal during each hand of the game is to have the highest point total that does not exceed 21 points. You will use the interactive touch screen on the display to play the game. Follow the steps below to play Blackjack.

Note: For detailed instructions on how to play Blackjack, consult a card game rule book or other card game resource.

1. Begin pedaling or press any button on the console to turn on the console.

When you turn on the console, the display will light. The console will then be ready for use.

2. Select the Blackjack game.

To select the Blackjack game, press the Fitness Games button (see the drawing on page 13) repeatedly until the word BLACKJACK appears in the display.

3. Tap the screen to start the game.

As you pedal, tap the screen to begin the Blackjack game. After a moment, the words PLACE YOUR BET will appear in the display. Tap the screen to select the amount you want to bet on this hand. Note: You begin each game with 500 credits. As you win or lose credits during the game, your current total will be shown in the upper right corner of the display.

After you place a bet, a representation of a game table will appear in the display. The dealer's cards will appear in the upper left corner of the display. Your cards will appear in the lower left corner of the display. The game options will appear in three boxes on the right side of the display.

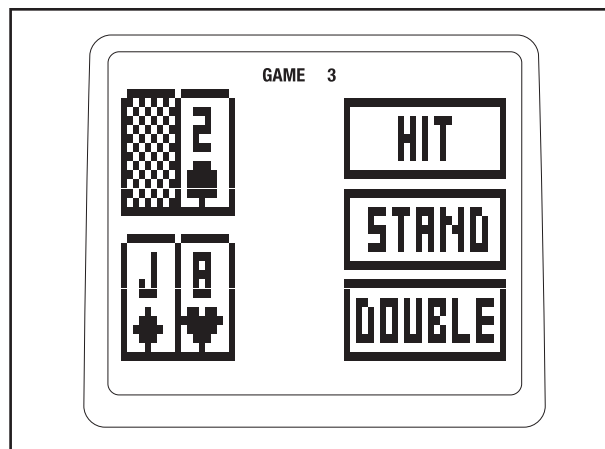

Count the point total of your cards and tap the screen to select a game option. You can choose to HIT, STAND, or DOUBLE. Repeat this action as necessary until the hand ends.

When the hand ends, the result and the point totals for you and the dealer will appear in a box on the right side of the display. To continue the game, tap the center of the screen.

The game will continue in this way indefinitely or until you have no credits available to bet. If you have no credits to bet, the words GAME OVER and the game time will appear in the display. To play Blackjack again, tap the prompt box on the screen.

4. Follow your progress with the display.

While you pedal and play the Blackjack game, the upper left corner of the display will show the elapsed time. To view additional exercise information, press the Display button repeatedly.

5. When you are finished exercising, the console will turn off automatically.

See step 6 on page 15.

HOW TO PLAY THE TEXAS HOLD 'EM GAME

Texas Hold 'Em is a popular poker game in which you compete against other players to win credits. Your objective is to form the best five-card poker hand from your two hole cards and the five community cards shared by all the players. You will use the interactive touch screen on the display to play the game. Follow the steps below to play Texas Hold 'Em.

Note: For detailed instructions on how to play Texas Hold 'Em, consult a card game rule book or other card game resource.

1. Begin pedaling or press any button on the console to turn on the console.

When you turn on the console, the display will light. The console will then be ready for use.

2. Select the Texas Hold 'Em game.

To select the Texas Hold 'Em game, press the Fitness Games button (see the drawing on page 13) repeatedly until the words TEXAS HOLD 'EM appear in the display.

3. Tap the screen to start the game.

As you pedal, tap the screen to begin the Texas Hold 'Em game. After you start the game, a representation of a game table will appear in the display. Your hole cards will be shown in the lower left corner of the display. The number of credits in the pot will be shown in the black box in the center of the display. The amount bet by each player will be shown along the right side of the display. A game option box will be shown below the pot.

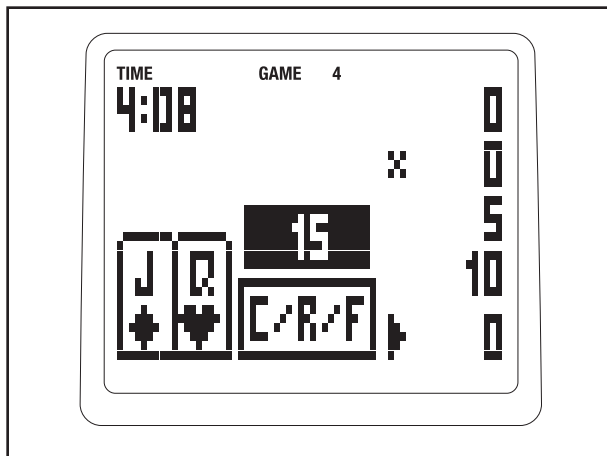

During the game, player information will appear along the right side of the display. Your player information is located in the lower right corner of

the display. The black X in the display indicates the location of the dealer button. The black arrow indicates which player's turn it is.

When it is your turn, assess your cards and tap the C/R/F game option box to make a betting decision; you can choose to CALL, RAISE, or FOLD. You can also tap the CARDS box to view your cards and any community cards on the table before making a decision. Note: In some circumstances, you can choose to CHECK instead of CALL.

If you decide to RAISE, tap the upward and downward arrow boxes to select the desired number of credits, and then tap the OK box.

After you make your betting decision, play will continue with the other players. Continue to make betting decisions throughout the betting rounds and the deals. When the flop is dealt, three cards will appear in the upper left area of the display. Additional cards will appear in this area when the turn and river are dealt. Assess these cards and make betting decisions as before. During the game, the other players may fold, bust, or continue to a showdown.

The player with the best five-card hand in any combination of hole and community cards will win the showdown.

After the showdown, the word WINS: will appear in the center of the display. The number of credits won by each player will be shown along the right side of the display. To view the cards held by the other players, tap the number of credits won by each player.

The game will continue in this way until you win all the other players' credits or until you have no credits available to bet.

4. Follow your progress with the display.

While you pedal and play the Texas Hold 'Em game, the upper left corner of the display will show the elapsed time. To view additional exercise information, press the Display button repeatedly.

5. When you are finished exercising, the console will turn off automatically.

See step 6 on page 15.

HOW TO USE AN IFIT WORKOUT

iFit cards are available separately. To purchase iFit cards, go to www.iFit.com or see the front cover of this manual. iFit cards are also available at select stores.

1. Begin pedaling or press any button on the console to turn on the console.

When you turn on the console, the display will light. The console will then be ready for use.

2. Insert an iFit card and select a workout.

To use an iFit workout, insert an iFit card into the iFit slot; make sure that the iFit card is oriented so that the metal contacts are face down and are facing the slot. When the iFit card is properly inserted, the indicator next to the slot will light and text will appear in the display.

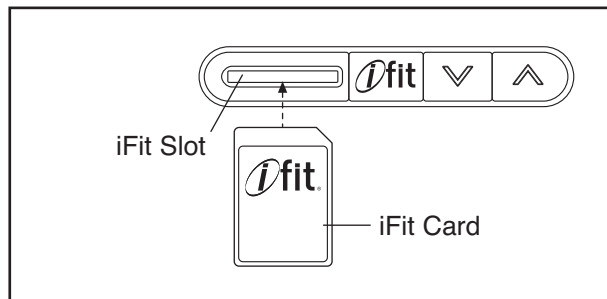

Next, select the desired workout on the iFit card by pressing the increase and decrease buttons next to the iFit slot.

A moment after you select a workout, the voice of a personal trainer will begin guiding you through your workout.

iFit workouts function in the same way as preset workouts. To use the workout, see steps 3 to 6 on page 16.

3. When you are finished exercising, remove the iFit card.

Remove the iFit card when you are finished exercising. Store the iFit card in a secure place.

HOW TO USE THE SOUND SYSTEM

To play music or audio books through the console's sound system while you exercise, plug the included audio cable into the jack on the console and into a jack on your MP3 player or CD player; **make sure that the audio cable is fully plugged in.**

Next, press the play button on your MP3 player or CD player. Adjust the volume level using the volume control on your MP3 player or CD player or press the Volume increase and decrease buttons on the console.

When not in use, unplug the audio cable from the jack on the console.

HOW TO CHANGE THE CONSOLE SETTINGS

The console features a display settings mode that allows you to select a backlight option, to select a unit of measurement for the console, and to turn the game sounds on or off. Follow the steps below to change the console settings.

1. Enter the display settings mode.

To enter the display settings mode, first press the Display button repeatedly until the words HOLD DISPLAY FOR SETTINGS appear in the display.

Then, press and hold the Display button until the display settings information appears in the display.

2. Select a backlight option if desired.

The console has three backlight options. The ON option keeps the backlight on while the console is on. The AUTO option keeps the backlight on only while you are pedaling. The OFF option turns the backlight off.

An X will appear next to the currently selected backlight option. To change the backlight option, press the resistance increase and decrease buttons to choose the desired backlight option.

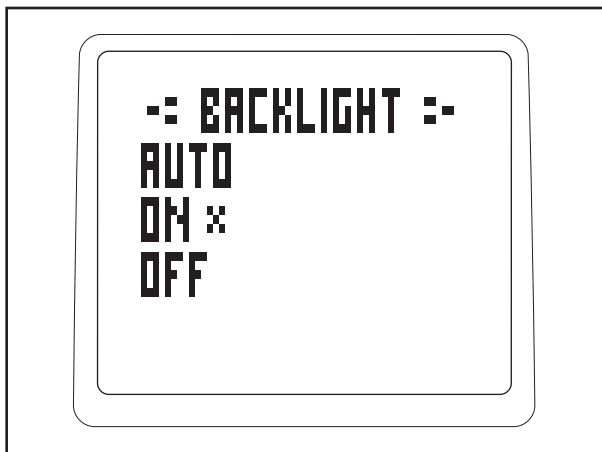

Then, press the Display button to proceed to the next option.

3. Select a unit of measurement if desired.

The console can show pedaling speed and distance in either miles or kilometers.

The word ENGLISH for English miles or the word METRIC for metric kilometers will appear in the display. An X will appear next to the currently selected unit of measurement.

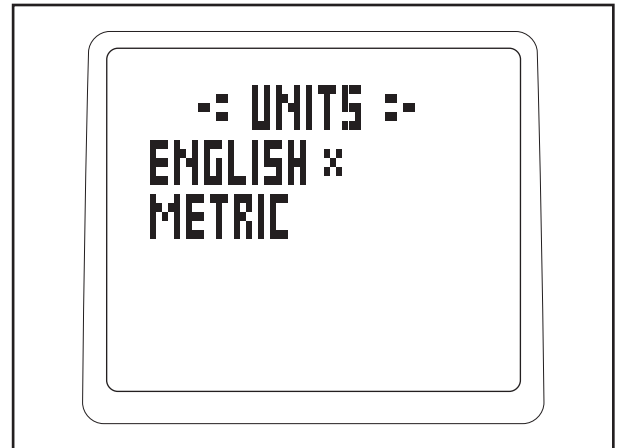

To change the unit of measurement, press the resistance increase and decrease buttons to choose the desired unit of measurement.

Then, press the Display button to proceed to the next option.

4. Turn the game sounds on or off if desired.

The console game sounds can be turned on or turned off. The words OFF and ON will appear in the display. An X will appear next to the currently selected option.

To change the option, press the resistance increase and decrease buttons to choose ON or OFF.

5. Exit the display settings mode.

Press the Display button to save your settings and exit the display settings mode.

MAINTENANCE AND TROUBLESHOOTING

Inspect and tighten all parts of the exercise cycle regularly. Replace any worn parts immediately.

To clean the exercise cycle, use a damp cloth and a small amount of mild soap. **IMPORTANT: To avoid damage to the console, keep liquids away from the console and keep the console out of direct sunlight.**

CONSOLE TROUBLESHOOTING

If the console display becomes dim, the batteries should be replaced; most console problems are the result of low batteries. See assembly step 5 on page 8 for replacement instructions. If the handgrip pulse sensor does not function properly, see step 5 on page 15.

HOW TO ADJUST THE REED SWITCH

If the console does not display correct feedback, the reed switch should be adjusted. To adjust the reed switch, you must first remove the left pedal and the left front shield. Using an adjustable wrench, turn the left pedal clockwise and remove it. Next, remove all the screws from the left and right front shields; **there are two sizes of screws in the front shields—note which size of screw you remove from each hole.** Then, gently pull the left front shield away from the frame.

Locate the Reed Switch (46). Turn the Pulley (29) until a Magnet (30) is aligned with the Reed Switch. Next, loosen, but do not remove, the indicated M4 x 16mm Screw (57). Slide the Reed Switch slightly closer to or away from the Magnet, and then retighten the Screw. Turn the Pulley for a moment. Repeat these actions until the console displays correct feedback. When the Reed Switch is correctly adjusted, reattach the front shields and the left pedal.

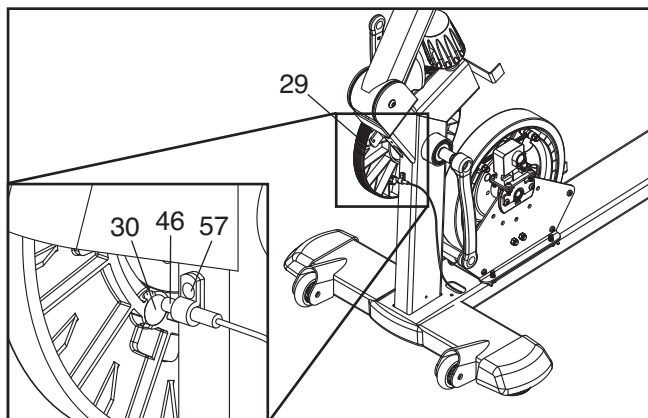

HOW TO ADJUST THE DRIVE BELT

If the pedals slip while you are pedaling, even while the resistance is adjusted to the highest setting, the drive belt may need to be adjusted. To adjust the drive belt, you must first remove the right pedal and the right front shield. Using an adjustable wrench, turn the right pedal counterclockwise and remove it. Next, remove all the screws from the left and right front shields; **there are two sizes of screws in the front shields—note which size of screw you remove from each hole.** Then, gently pull the right front shield away from the frame.

Loosen, but do not remove, the three indicated screws (A). Insert the shaft of a screwdriver downward between the Idler (B) and the Idler Pulley (38). Pull the top of the screwdriver toward the rear of the exercise cycle until the Drive Belt (47) is tight. Tighten the three screws. Then, reattach the front shields and the right pedal.

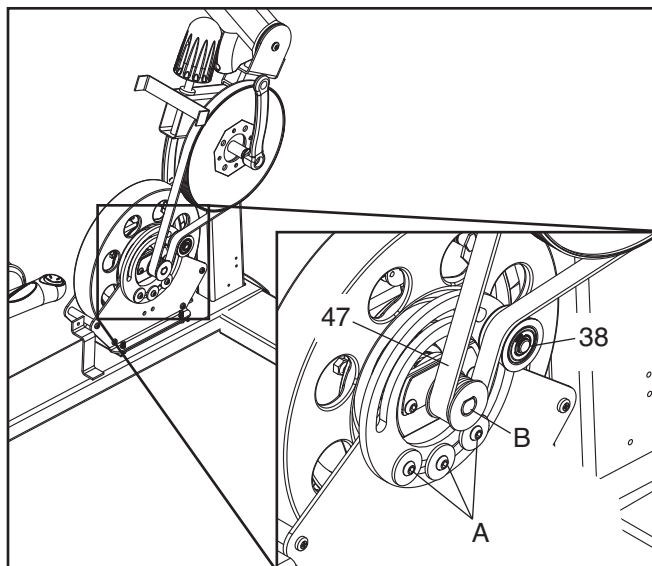

EXERCISE GUIDELINES

⚠ WARNING: Before beginning this or any exercise program, consult your physician. This is especially important for persons over age 35 or persons with pre-existing health problems.

The pulse sensor is not a medical device. Various factors may affect the accuracy of heart rate readings. The pulse sensor is intended only as an exercise aid in determining heart rate trends in general.

These guidelines will help you to plan your exercise program. For detailed exercise information, obtain a reputable book or consult your physician. Remember, proper nutrition and adequate rest are essential for successful results.

EXERCISE INTENSITY

Whether your goal is to burn fat or to strengthen your cardiovascular system, exercising at the proper intensity is the key to achieving results. You can use your heart rate as a guide to find the proper intensity level. The chart below shows recommended heart rates for fat burning and aerobic exercise.

165	155	145	140	130	125	115	♥♥
145	138	130	125	118	110	103	♥
125	120	115	110	105	95	90	♥
20	30	40	50	60	70	80	

To find the proper intensity level, find your age at the bottom of the chart (ages are rounded off to the nearest ten years). The three numbers listed above your age define your “training zone.” The lowest number is the heart rate for fat burning, the middle number is the heart rate for maximum fat burning, and the highest number is the heart rate for aerobic exercise.

Burning Fat—To burn fat effectively, you must exercise at a low intensity level for a sustained period of time. During the first few minutes of exercise, your body uses *carbohydrate calories* for energy. Only after the first few minutes of exercise does your body begin to use stored *fat calories* for energy. If your goal is to burn fat, adjust the intensity of your exercise until your heart rate is near the lowest number in your training zone. For maximum fat burning, exercise with your heart rate near the middle number in your training zone.

Aerobic Exercise—If your goal is to strengthen your cardiovascular system, you must perform aerobic exercise, which is activity that requires large amounts of oxygen for prolonged periods of time. For aerobic exercise, adjust the intensity of your exercise until your heart rate is near the highest number in your training zone.

WORKOUT GUIDELINES

Warming Up—Start with 5 to 10 minutes of stretching and light exercise. A warm-up increases your body temperature, heart rate, and circulation in preparation for exercise.

Training Zone Exercise—Exercise for 20 to 30 minutes with your heart rate in your training zone. (During the first few weeks of your exercise program, do not keep your heart rate in your training zone for longer than 20 minutes.) Breathe regularly and deeply as you exercise—never hold your breath.

Cooling Down—Finish with 5 to 10 minutes of stretching. Stretching increases the flexibility of your muscles and helps to prevent post-exercise problems.

EXERCISE FREQUENCY

To maintain or improve your condition, complete three workouts each week, with at least one day of rest between workouts. After a few months of regular exercise, you may complete up to five workouts each week, if desired. Remember, the key to success is to make exercise a regular and enjoyable part of your everyday life.

PART LIST—Model No. PFEX03409.0

R0709A

Key No.	Qty.	Description	Key No.	Qty.	Description
1	1	Frame	47	1	Drive Belt
2	1	Upright	48	2	Rear Stabilizer Cap
3	1	Seat Carriage	49	1	Seat Handle
4	1	Console	50	2	Flange Screw
5	2	Crank Cover	51	2	M6 x 42mm Patch Screw
6	2	Accent Ring	52	4	M8 x 50mm Patch Screw
7	1	Upright Knob	53	8	M6 Locknut
8	1	Backrest	54	6	M8 x 16mm Patch Screw
9	1	Seat	55	10	M8 Split Washer
10	2	Game Grip	56	2	Bumper
11	1	Seat Handlebar	57	17	M4 x 16mm Screw
12	2	Brake Pad Spacer	58	1	Game/Pulse Wire
13	1	Left Front Shield	59	1	Right Handlebar
14	1	Right Front Shield	60	1	Left Handlebar
15	1	Left Front Stabilizer	61	6	M8 Locknut
16	1	Rear Stabilizer	62	1	M10 x 63mm Bolt Set
17	2	Wheel	63	4	Wheel Bushing
18	2	Upper Roller	64	1	Brake Pad
19	2	Leveling Foot	65	1	Frame Cover
20	2	Upright Bushing	66	2	Front Stabilizer Cap
21	1	Right Pedal/Strap	67	4	M10 x 40mm Patch Screw
22	1	Left Pedal/Strap	68	1	Upright Cover
23	1	Right Crank	69	2	M8 x 48mm Button Bolt
24	1	Left Crank	70	1	Bright M4 x 12mm Screw
25	1	Seat Lock Bracket	71	2	Lower Roller
26	1	Left Shield	72	4	M8 x 38mm Button Bolt
27	1	Right Shield	73	4	M6 x 20mm Button Bolt
28	1	Large Snap Ring	74	1	Water Bottle Holder
29	1	Pulley	75	4	Roller Axle
30	2	Magnet	76	5	M6 x 9mm Patch Screw
31	1	Spindle	77	10	M6 x 18mm Patch Screw
32	1	Steel Washer	78	2	M10 x 32mm Button Bolt
33	2	Crank Bearing	79	1	Game/Pulse Receptacle/Wire
34	1	Eddy Mechanism	80	4	M4 x 16mm Flange Screw
35	1	Eddy Axle Assembly	81	4	M6 x 38mm Patch Screw
36	2	Seat Carriage Cap	82	1	M4 x 12mm Screw
37	4	Handlebar Cap	83	1	Frame Cap
38	1	Idler Pulley	84	5	M4 x 19mm Screw
39	1	Idler	85	2	Spindle Cover
40	1	Right Front Stabilizer	86	1	Rail
41	1	Seat Lock	87	2	M10 Locknut
42	1	Game/Pulse Wire Harness	88	1	Audio Wire
43	1	Main Wire Harness	*	—	Pillow Block
44	12	M6 Washer	*	—	Resistance Motor
45	1	Clamp	*	—	Hex Key
46	1	Reed Switch/Wire	*	—	User's Manual

Note: Specifications are subject to change without notice. For information about ordering replacement parts, see the back cover of this manual. *These parts are not illustrated.

EXPLODED DRAWING A—Model No. PFEX03409.0

R0709A

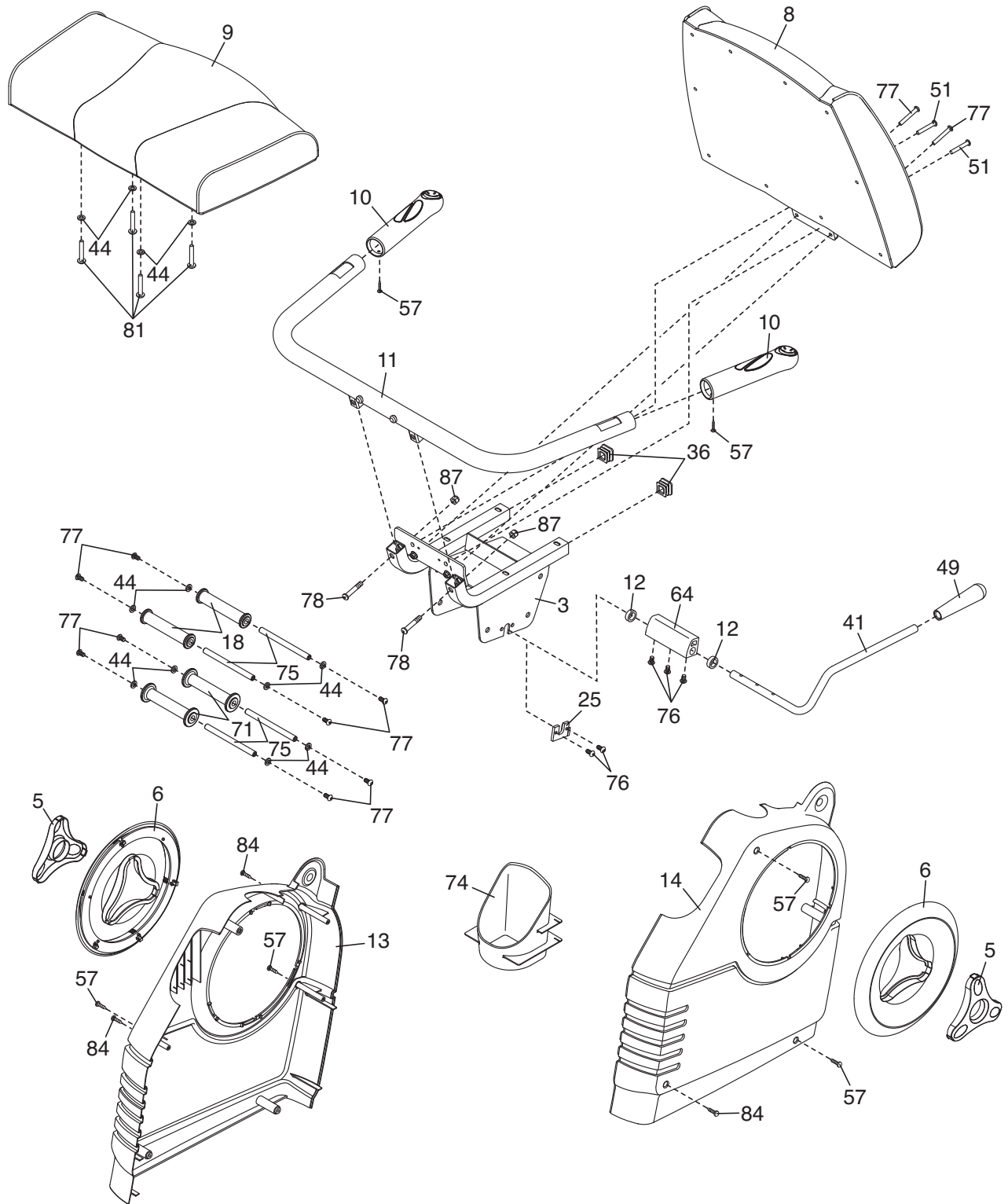

EXPLODED DRAWING B—Model No. PFEX03409.0

R0709A

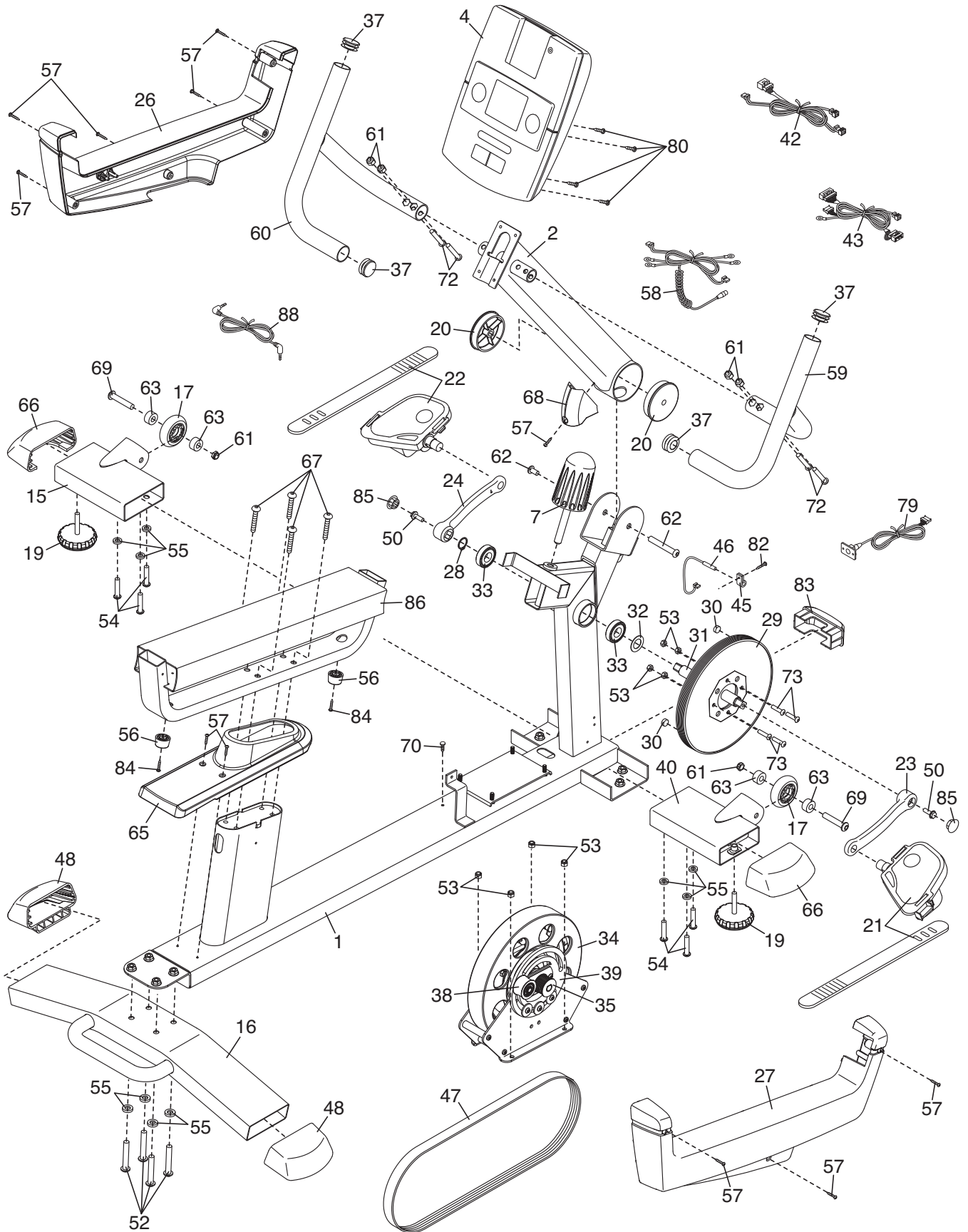

ORDERING REPLACEMENT PARTS

To order replacement parts, please see the front cover of this manual. To help us assist you, be prepared to provide the following information when contacting us:

- the model number and serial number of the product (see the front cover of this manual)
- the name of the product (see the front cover of this manual)
- the key number and description of the replacement part(s) (see the PART LIST and the EXPLODED DRAWING near the end of this manual)

LIMITED WARRANTY

IMPORTANT: You must register this product within 30 days of the purchase date to avoid added fees for service needed under warranty. Go to www.proformservice.com/registration.

ICON Health & Fitness, Inc. (ICON) warrants this product to be free from defects in workmanship and material, under normal use and service conditions. The frame is warranted for seven (7) years from the date of purchase. Parts and labor are warranted for ninety (90) days from the date of purchase.

This warranty extends only to the original purchaser. ICON's obligation under this warranty is limited to repairing or replacing, at ICON's option, the product through one of its authorized service centers. All repairs for which warranty claims are made must be preauthorized by ICON. If the product is shipped to a service center, freight charges to and from the service center will be the customer's responsibility. For replacement parts shipped while the product is under warranty, the customer will be responsible for a minimal handling charge. For in-home service, the customer will be responsible for a minimal trip charge. This warranty does not extend to any damage to a product caused by or attributable to freight damage, abuse, misuse, improper or abnormal usage, or repairs not provided by an ICON authorized service center; to products used for commercial or rental purposes or as store display models; or to products transported or purchased outside the US. No other warranty beyond that specifically set forth above is authorized by ICON.

ICON is not responsible or liable for indirect, special, or consequential damages arising out of or in connection with the use or performance of the product; damages with respect to any economic loss, loss of property, loss of revenues or profits, loss of enjoyment or use, or costs of removal or installation; or other consequential damages of whatsoever nature. Some states do not allow the exclusion or limitation of incidental or consequential damages. Accordingly, the above limitation may not apply to you.

The warranty extended hereunder is in lieu of any and all other warranties, and any implied warranties of merchantability or fitness for a particular purpose are limited in their scope and duration to the terms set forth herein. Some states do not allow limitations on how long an implied warranty lasts. Accordingly, the above limitation may not apply to you.

This warranty gives you specific legal rights. You may also have other rights that vary from state to state.

ICON Health & Fitness, Inc., 1500 S. 1000 W., Logan, UT 84321-9813