

---

**UDC3300**  
**Expanded Model: DC33XE**  
**User Manual**

51-52-25-100

12/00

---

---











# About This Document

## Abstract

This manual contains all the information that is needed to install, configure and operate the UDC3300 Universal Digital Controller.

## Symbol Definitions

The following table lists those symbols that may be used in this document to denote certain conditions.

Symbol	Definition
	This <b>DANGER</b> symbol indicates an imminently hazardous situation, which, if not avoided, <b>will result in death or serious injury</b> .
	This <b>WARNING</b> symbol indicates a potentially hazardous situation, which, if not avoided, <b>could result in death or serious injury</b> .
	This <b>CAUTION</b> symbol may be present on Control Product instrumentation and literature. If present on a product, the user must consult the appropriate part of the accompanying product literature for more information.
	This <b>CAUTION</b> symbol indicates a potentially hazardous situation, which, if not avoided, <b>may result in property damage</b> .
	<b>WARNING</b> <b>PERSONAL INJURY:</b> Risk of electrical shock. This symbol warns the user of a potential shock hazard where HAZARDOUS LIVE voltages greater than 30 Vrms, 42.4 Vpeak, or 60 Vdc may be accessible. <b>Failure to comply with these instructions could result in death or serious injury.</b>
	ATTENTION, Electrostatic Discharge (ESD) hazards. Observe precautions for handling electrostatic sensitive devices
	Protective Earth (PE) terminal. Provided for connection of the protective earth (green or green/yellow) supply system conductor.
	Functional earth terminal. Used for non-safety purposes such as noise immunity improvement. NOTE: This connection shall be bonded to protective earth at the source of supply in accordance with national local electrical code requirements.
	Earth Ground. Functional earth connection. NOTE: This connection shall be bonded to Protective earth at the source of supply in accordance with national and local electrical code requirements.
	Chassis Ground. Identifies a connection to the chassis or frame of the equipment shall be bonded to Protective Earth at the source of supply in accordance with national and local electrical code requirements.

---

---

# Contents

<b>1.</b>	<b>INTRODUCTION</b> .....	<b>1</b>
1.1	Overview .....	1
1.2	CE Conformity (Europe) .....	1
1.3	Function Keys .....	2
<b>2.</b>	<b>INSTALLATION</b> .....	<b>3</b>
2.1	Mounting .....	3
2.2	Wiring.....	4
<b>3.</b>	<b>CONFIGURATION</b> .....	<b>19</b>
3.1	Overview .....	19
3.2	Configuration Procedure .....	22
3.3	Loop 1 Tuning Parameters Set Up Group .....	23
3.4	Loop 2 Tuning Parameters Set Up Group .....	25
3.5	SP Ramp, SP Rate, or SP Programming Set Up Group.....	27
3.6	Accutune Set Up Group .....	29
3.7	Algorithm Data Set Up Group.....	30
3.8	Output Algorithm Parameters Set Up Group .....	34
3.9	Input 1 Parameters Set Up Group .....	36
3.10	Input 2 Parameters Set Up Group .....	37
3.11	Input 3 Parameters Set Up Group .....	39
3.12	Loop 1 Control Parameters Set Up Group.....	40
3.13	Loop 2 Control Parameters Set Up Group.....	42
3.14	Options Set Up Group .....	44
3.15	Communications Set Up Group .....	45
3.16	Alarms Set Up Group .....	47
3.17	Display Parameters Set Up Group .....	49
3.18	Calibration Group .....	50
3.19	Maintenance Parameters Set Up Group.....	50
3.20	Status Group .....	51
<b>4.</b>	<b>OPERATION</b> .....	<b>53</b>
4.1	How to Power Up the Controller .....	53
4.2	Monitoring Your Controller.....	53
4.3	Start-up Procedure .....	56
4.4	Operating Modes.....	57

---

4.5	Setpoints .....	57
4.6	Using Two Sets of Tuning Constants .....	58
4.7	Alarm Setpoints .....	60
4.8	Two Loops of Control .....	60
4.9	Monitoring Two Loops of Control.....	67
4.10	Operating Two Loops of Control.....	68
4.11	Three Position Step Control Algorithm .....	69
4.12	Input Math Algorithms .....	69
4.13	Digital Input Option (Remote Switching).....	72
4.14	Fuzzy Overshoot Suppression.....	74
4.15	Accutune .....	74
4.16	Entering a Security Code .....	79
4.17	Carbon Potential .....	80
4.18	Health Watch .....	81
<b>5.</b>	<b>SETPOINT RATE/RAMP/SOAK PROGRAM OPERATION.....</b>	<b>83</b>
5.1	Setpoint Ramp Rate .....	83
5.2	Single Setpoint Ramp.....	83
5.3	Setpoint Ramp/Soak Programming Option.....	85
<b>6.</b>	<b>APPENDIX A – ENVIRONMENTAL AND OPERATING CONDITIONS .....</b>	<b>93</b>
<b>7.</b>	<b>APPENDIX B – MODEL SELECTION GUIDE .....</b>	<b>95</b>
<b>8.</b>	<b>APPENDIX C – CONFIGURATION RECORD SHEET .....</b>	<b>97</b>
<b>9.</b>	<b>APPENDIX D – POSITION PROPORTIONAL CALIBRATION .....</b>	<b>101</b>
9.1	Position Proportional Control Output Calibration .....	101
<b>10.</b>	<b>APPENDIX E – INPUT RANGES.....</b>	<b>105</b>

**CE MARK MULTILANGUAGE SAFETY SHEETS**

---

# Tables

Table 1-1	Function of Keys	2
Table 2-1	Permissible Wiring Bundling	5
Table 2-2	Input 2 Jumper Selections	9
Table 2-3	Control Relay Contact Information	18
Table 2-4	Alarm Relay Contact Information	18
Table 3-1	Configuration Procedure	22
Table 3-2	Loop 1 Tuning Group Function Prompts	23
Table 3-3	Loop 2 Tuning Group Function Prompts	25
Table 3-4	SP Ramp Function Prompts	27
Table 3-5	Accutune Group Function Prompts	29
Table 3-6	Algorithm Group Function Prompts	30
Table 3-7	Output Algorithm Group Function Prompts	34
Table 3-8	Input 1 Group Function Prompts	36
Table 3-9	Input 2 Group Function Prompts	37
Table 3-10	Input 3 Group Function Prompts	39
Table 3-11	Control Group Function Prompts	40
Table 3-12	Loop 2 Control Parameters Set Up Group	42
Table 3-13	Options Group Function Prompt	44
Table 3-14	Communications Group Function Prompts	45
Table 3-15	Alarms Group Function Prompts	47
Table 3-16	Display Group Function Prompts	49
Table 3-17	Maintenance Group Function Prompts	50
Table 4-1	Lower Display Key Parameter Prompts	54
Table 4-2	Error Messages	55
Table 4-3	Procedure for Starting Up the Controller	56
Table 4-4	Setpoint Selection Indication	58
Table 4-5	Procedure for Selecting Two Sets of Tuning Constants	58
Table 4-6	Procedure for Setting Switchover Values	58
Table 4-7	Procedure for Setting Tuning Constant Values	59
Table 4-8	Procedure for Switching PID SETS from the Keyboard	59
Table 4-9	Procedure for Displaying or Changing the Alarm Setpoints	60
Table 4-10	Control Loops Selections	63
Table 4-11	Two Loop Functionality and Restrictions (Models DC330E-EE-2XX or DC330E-EE-5XX)	64
Table 4-12	Two Loop Functionality and Restrictions (Models DC330E-KE-2XX or DC330E-KE-5XX)	65
Table 4-13	Procedure for Selecting 2-loop Algorithm	66
Table 4-14	Procedure for Selecting Output Algorithm	66
Table 4-15	Procedure for Selecting Control Parameters	66
Table 4-16	Procedure for Selecting Tuning Parameters	67
Table 4-17	Digital Display Indication—Two Loops	67
Table 4-18	Procedure for Displaying the 3PSTEP Motor Position	69
Table 4-19	Digital Input Option Action on Contact Closure	72
Table 4-20	Digital Input Combinations “DIG IN1” or “DIG IN2”	74
Table 4-21	Accutune Rules and Regulations	75
Table 4-22	Procedure for Starting TUNE (Demand) Tuning	76
Table 4-23	Procedure for Using TUNE at Start-up for Duplex	77
Table 4-24	Procedure for Using SP Tuning at Start-Up	77

---

Table 4-25	Procedure to Enter a Security Code	79
Table 5-1	Procedure for Running a Setpoint Ramp	84
Table 5-2	Program Contents	86
Table 5-3	Run/Monitor Functions	90
Table 9-1	Calibration Procedure	102

---

# Figures

Figure 1-1	Operator Interface Displays and Indicators	1
Figure 2-1	Dimensions	3
Figure 2-2	Mounting Method	4
Figure 2-3	Composite Wiring Diagram	6
Figure 2-4	Line Voltage Wiring	7
Figure 2-5	Input #1/#2 Connections	8
Figure 2-6	Two HLAI Replace 2nd LLAI Connections	9
Figure 2-7	Electromechanical Relay Output – Model DC330X-EE-XXX	10
Figure 2-8	Solid State (SS) Relay Output — Model DC33-X-AA-XX	11
Figure 2-9	10-amp SS External Relay Output — Model DC330X-SS-XX	11
Figure 2-10	Open Collector Output — Model DC330X-TT-XXX	12
Figure 2-11	Current Output Current/Time Duplex, Time/Current Duplex, Position Proportional or Three Position Step Control	13
Figure 2-12	Auxiliary Output and Three-Relay Output	13
Figure 2-13	Position Proportional Output or Three Position Step—Models DC330X-EE-XXX-X2, DC330X-AA-XXX-X2	14
Figure 2-14	Auxiliary Output Connections— Models DC330X-XX-2XX, DC330X-XX-5XX	15
Figure 2-15	Digital Inputs Connections—Model DC330X-XX-XX3	15
Figure 2-16	RS422/485/ASCII or Modbus Communications Option Connections	16
Figure 2-17	Transmitter Power for 4-20 mA 2-wire Transmitter Using Open Collector Alarm 2 Output—Model DC330X-XT-XXX	17
Figure 2-18	Transmitter Power for 4-20 mA 2-wire Transmitter Using Auxiliary Output—Model DC330X-XX-2XX or DC330X-XX-5XX	17
Figure 3-1	Prompt Hierarchy	19
Figure 4-1	Functional Overview Block Diagram of a Single Loop (Loop #1) or Dual Loop Controller (Loop #1 and Loop #2)	61
Figure 4-2	Functional Overview Block Diagram of Internal Cascade of a 2-loop Controller	62
Figure 4-3	UDC3300 Controller Being Used to Control the Carbon Potential of a Furnace's Atmosphere	80
Figure 5-1	Ramp/Soak Profile Example	88
Figure 5-2	Program Record Sheet	89





# 1. Introduction

## 1.1 Overview

The UDC3300 is a microprocessor-based, stand-alone controller. It combines the highest degree of functionality and operating simplicity offered in a 1/4 DIN size controller.

With a typical accuracy of  $\pm 0.20\%$  of span, the UDC3300 is an ideal controller for regulating temperature and other process variables in numerous heating and cooling applications, in metal working, food, and pharmaceuticals, and testing and environmental work.

## 1.2 CE Conformity (Europe)

This product is in conformity with the protection requirements of the following European Council Directives: **73/23/EEC**, the Low Voltage Directive, and **89/336/EEC**, the EMC Directive. Conformity of this product with any other "CE Mark" Directive(s) shall not be assumed.

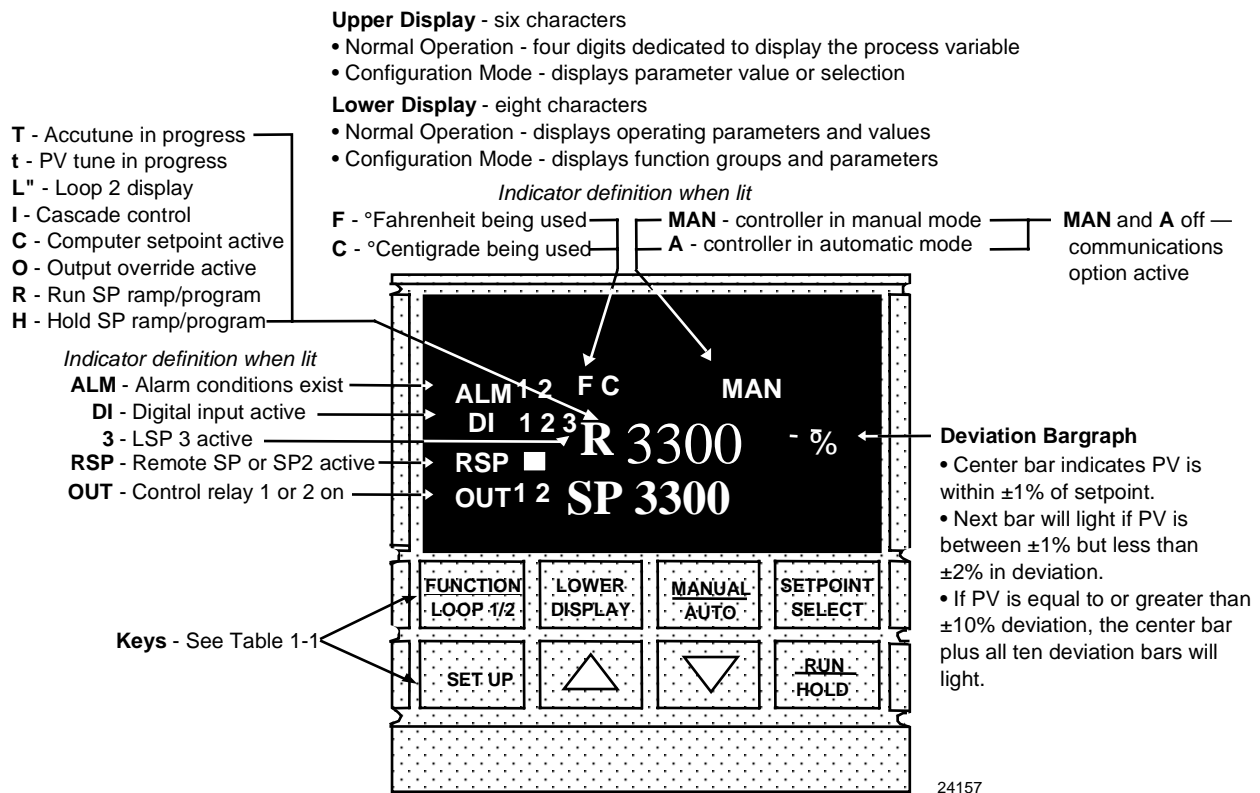

Figure 1-1 Operator Interface Displays and Indicators

## 1.3 Function Keys

**Table 1-1 Function of Keys**

Key	Function
<b>SET UP</b>	Places the controller in the Configuration Set Up group select mode. Sequentially displays Set Up groups and allows the FUNCTION key to display individual functions in each Set Up group.
<b><u>FUNCTION</u> LOOP 1/2</b>	<ul style="list-style-type: none"><li>• Used in conjunction with the SET UP key to select the individual functions of a selected Configuration Set Up group. .</li><li>• Selects Display of Loop 1 or Loop 2 during operation.</li></ul>
<b>LOWER DISPLAY</b>	Selects an operating parameter to be shown in the lower display.
<b><u>MANUAL</u> AUTO</b>	Alternately selects AUTO or MAN .
<b>SETPOINT SELECT</b>	Hold key down to cycle through configured setpoints.
<b><u>RUN</u> HOLD</b>	<ul style="list-style-type: none"><li>• Alternate action switch initiates or holds the Setpoint Ramp or Setpoint Program.</li><li>• Acknowledges a latched alarm 1.</li></ul>
<b>▲</b>	Increases the selected parameter value.
<b>▼</b>	Decreases the selected parameter value.

## 2. Installation

### 2.1 Mounting

#### Physical Considerations

The controller can be mounted on either a vertical or tilted panel using the mounting kit supplied. Adequate access space must be available at the back of the panel for installation and servicing activities.

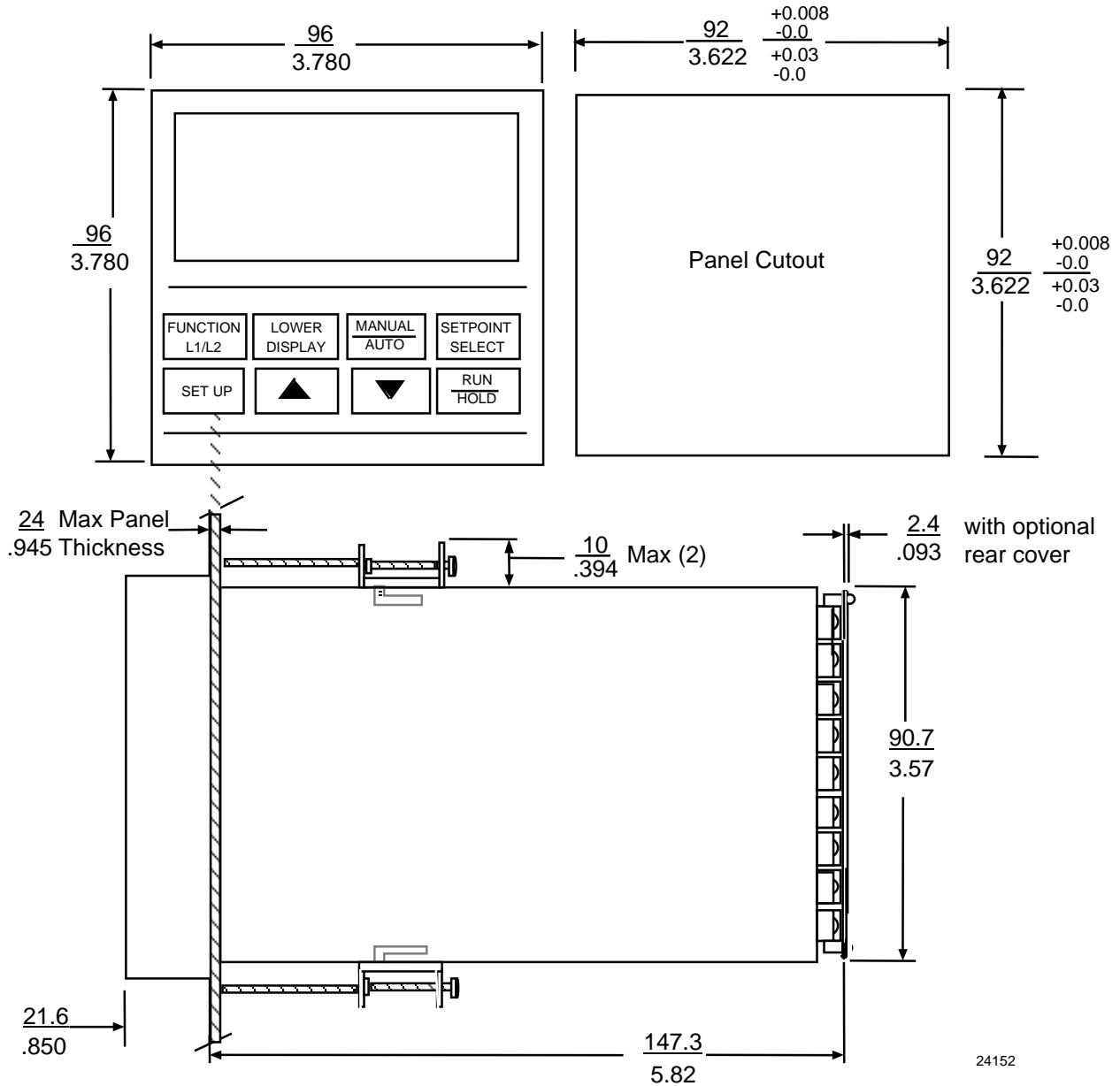
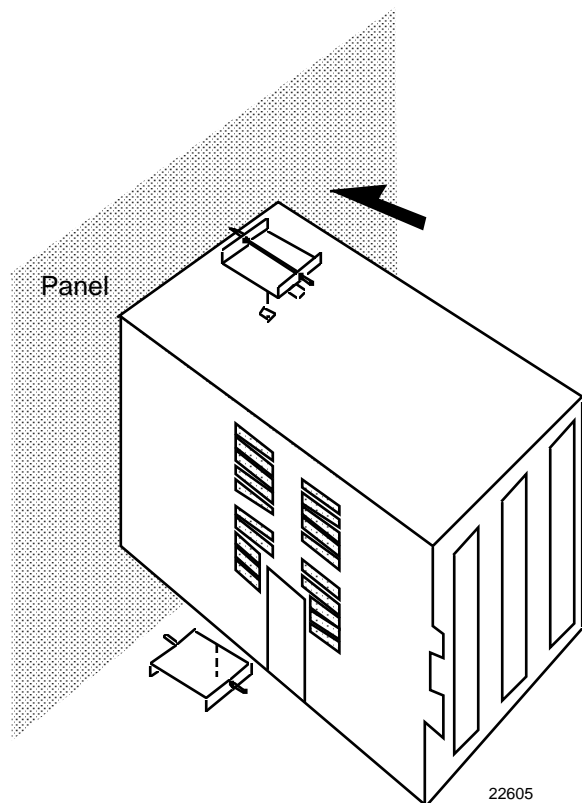

Figure 2-1 Dimensions

## Mounting Method

Before mounting the controller, refer to the nameplate on the inside of the case and make a note of the model number. It will help later when selecting the proper wiring configuration.



Remove the mounting kit from the shipping container, and install the kit as follows:

- Install the screws into the threaded holes of the clips.
- Insert the prongs of the clips into the two holes in the top and bottom of the case.
- Tighten both screws to secure the case against the panel.
- Carefully slide the chassis assembly into the case, press to close and tighten the screw. Replace the screw cover.

Figure 2-2 Mounting Method

## 2.2 Wiring

### Electrical Considerations/Precautions

The controller is considered “rack and panel mounted equipment” per EN 61010-1, Safety Requirements for Electrical Equipment for Measurement, Control, and Laboratory Use, Part 1: General Requirements. Conformity with 72/23/EEC, the Low Voltage Directive requires the user to provide adequate protection against a shock hazard. The user shall install this controller in an enclosure that limits OPERATOR access to the rear terminals.

### Controller Grounding

PROTECTIVE BONDING (grounding) of this controller and the enclosure in which it is installed shall be in accordance with National and local electrical codes. To minimize electrical noise and transients that may adversely affect the system, supplementary bonding of the controller enclosure to a local ground, using a No. 12 (4 mm<sup>2</sup>) copper conductor, is recommended.

## Control/Alarm Circuit Wire Rating

The insulation of wires connected to the Control/Alarm terminals shall be rated for the highest voltage involved. Extra Low Voltage (ELV) wiring (input, current output, and low voltage Control/Alarm circuits) shall be separated from HAZARDOUS LIVE (>30 Vac, 42.4 Vpeak, or 60 Vdc) wiring per Table 2-1.

## Electrical Noise Precautions

Electrical noise is composed of unabated electrical signals which produce undesirable effects in measurements and control circuits.

Digital equipment is especially sensitive to the effects of electrical noise. Your controller has built-in circuits to reduce the effect of electrical noise from various sources. Be sure to separate external wiring into bundles (see Table 2-1) and route the individual bundles through separate conduits or metal trays.

### ATTENTION

For installation where high EMI/RFI noise cannot be avoided, we recommend you use shielded twisted pair wires for the signals in bundle 2.

**Table 2-1 Permissible Wiring Bundling**

Bundle No.	Wire Functions
1	<ul style="list-style-type: none"> <li>• Line power wiring</li> <li>• Earth ground wiring</li> <li>• Control relay output wiring</li> <li>• Line voltage alarm wiring</li> </ul>
2	Analog signal wire, such as: <ul style="list-style-type: none"> <li>• Input signal wire (thermocouple, 4 to 20 mA, etc.)</li> <li>• 4-20 mA output signal wiring</li> <li>• Slidewire feedback circuit wiring</li> <li>• Digital input signals</li> <li>• Communications</li> </ul>
3	<ul style="list-style-type: none"> <li>• Low voltage alarm relay output wiring</li> <li>• Low voltage wiring to solid state type control circuits</li> </ul>

## Composite Wiring

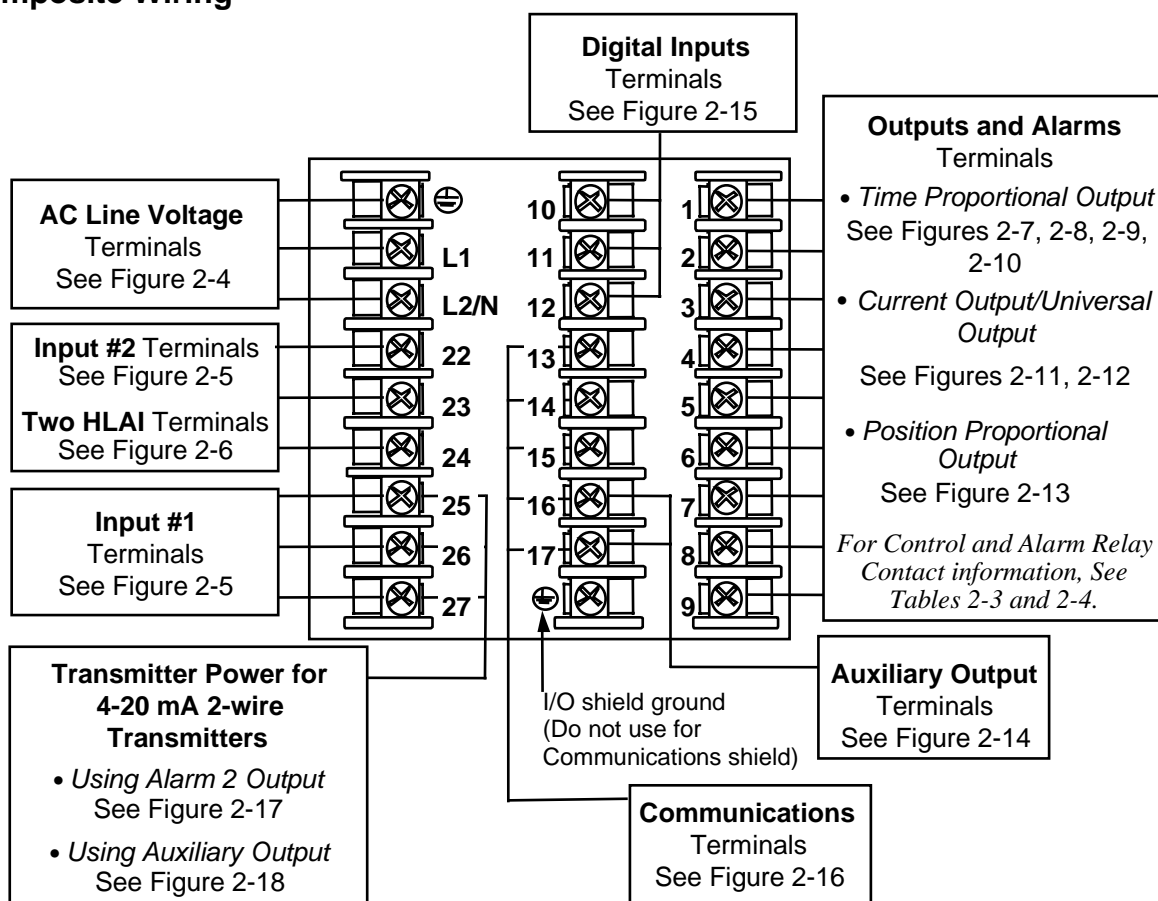

Figure 2-3 Composite Wiring Diagram

## Line Voltage Wiring

This equipment is suitable for connection to 90-264 Vac or 24 Vac/dc, 50/60 Hz, power supply mains. It is the user's responsibility to provide a switch and non-time delay (North America), quick-acting, high breaking capacity, Type F, (Europe) 1/2 A, 250 V fuse(s) or circuit-breaker for 90-264 V; or 1 A, 125 V fuse or circuit breaker for 24 Vac/dc operation, as part of the installation. The switch or circuit-breaker should be located close to the controller, *within easy reach of the operator*. The switch or circuit-breaker should be marked as the disconnecting device for the controller (4 mm<sup>2</sup>).

### CAUTION

Applying 90-264 Vac to a controller rated for 24 Vac/dc will severely damage the controller and is a fire and smoke hazard.

When applying power to multiple instruments, make sure that sufficient current is supplied. Otherwise, the instruments may not start up normally due to the voltage drop caused by the in-rush current.

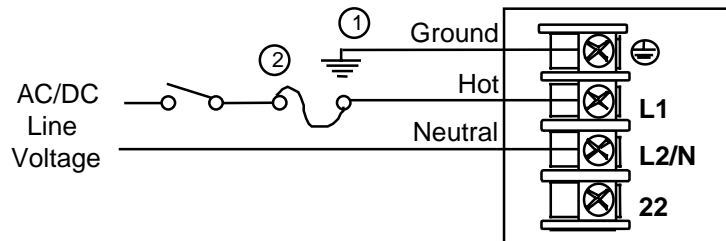

- ① PROTECTIVE BONDING (grounding) of this controller and the enclosure in which it is installed, shall be in accordance with National and local electrical codes. To minimize electrical noise and transients that may adversely affect the system, supplementary bonding of the controller enclosure to a local ground, using a No. 12 (4 mm<sup>2</sup>) copper conductor, is recommended.
- ② Provide a switch and non-time delay (North America), quick-acting, high breaking capacity, Type F (Europe), 1/2A, 250V fuse(s) or circuit-breaker for 90-264V; or 1A, 125V fuse or circuit breaker for 24 Vac/dc operation, as part of the installation.

**Figure 2-4 Line Voltage Wiring**

### Input#1/Input #2

INPUT #2 ③ Refer to Table 2-2 for Input 2 Jumper selections.

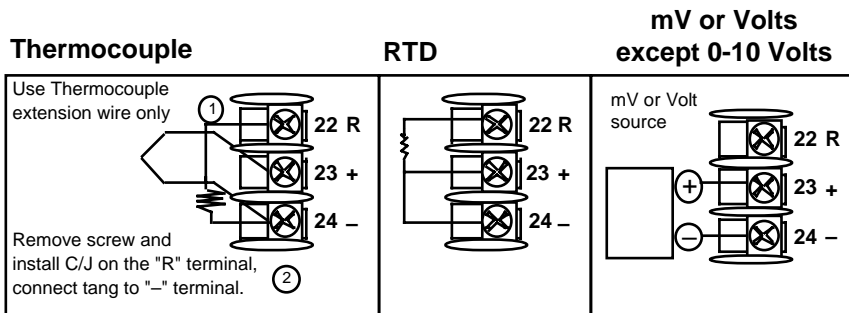

① The 250Ω load resistor for 4-20 mA or the voltage divider for 0-10 volts or the 500 ohm C/J compensation resistor is supplied with the controller when the input is specified. These items must be installed when you wire the controller before start-up.

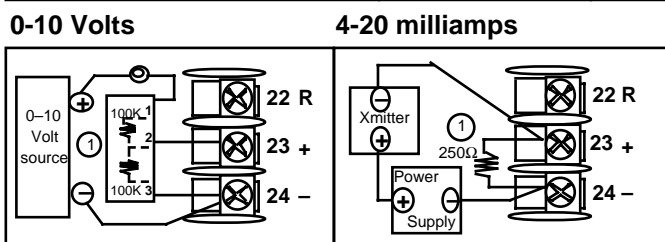

Input #2 is not available with Position Proportional Output.

### INPUT #1 ③

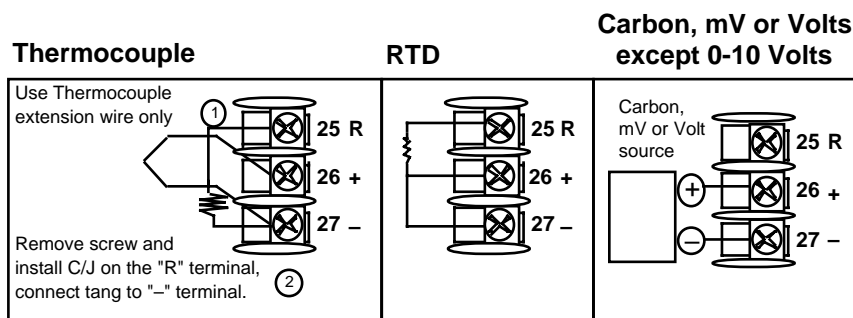

② When installing the cold junction (Part number 30757088-001) for a T/C input, remove the screws from terminals 25 and 27 (Input 1) or 22 and 24 (Input 2), and install the assembly into place.

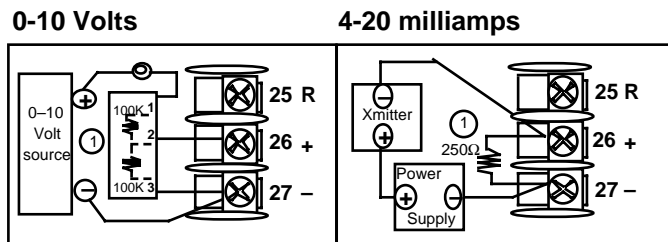

③ For **Relative Humidity** option, use Input 1 as the wet bulb input and Input 2 as the dry bulb input.

For **Carbon Potential** option, use Input 1 as the Carbon Probe input.

Figure 2-5 Input #1/#2 Connections



### Input 2 Jumper

**Table 2-2 Input 2 Jumper Selections**

<b>Jumper Location</b>			
<b>Jumper Position</b>	W1	W2	None (remove jumper)
<b>Input Types Available</b>	Slidewire	Thermocouple, RTD, mV, Radiamatic, Carbon, Oxygen, 4-20 mA, 0-20 mA, 1-5 V, 0-5 V	Two HLAI replace LLAI 4-20 mA, 0-20 mA, 1-5 V, 0-5 V

### High Level Analog Input Connections

ATTENTION: Remove Input 2 jumper when replacing second LLAI with two HLAI. Refer to Table 2-2.

#### 1-5V Connections

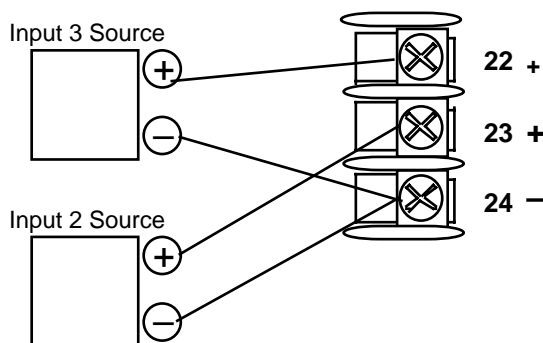

#### 4-20 mA Connections

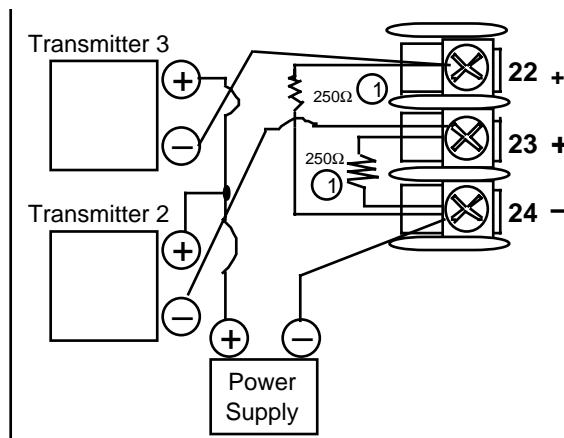

- ① The 250Ω load resistors are supplied by Honeywell with the controller when the input is specified. These items must be installed when you wire the controller before start-up.

**Figure 2-6 Two HLAI Replace 2nd LLAI Connections**

### Time Proportional Output

The three types of Time Proportional outputs available on the UDC3300 are shown in the following figures.

The Alarm wiring connections are the same for all three outputs.

*For Control and Alarm Relay Contact information, see Table 2-3 and Table 2-4.*

Figure 2-7 shows the Output and Alarm wiring connections for models with Electromechanical Relay Output.

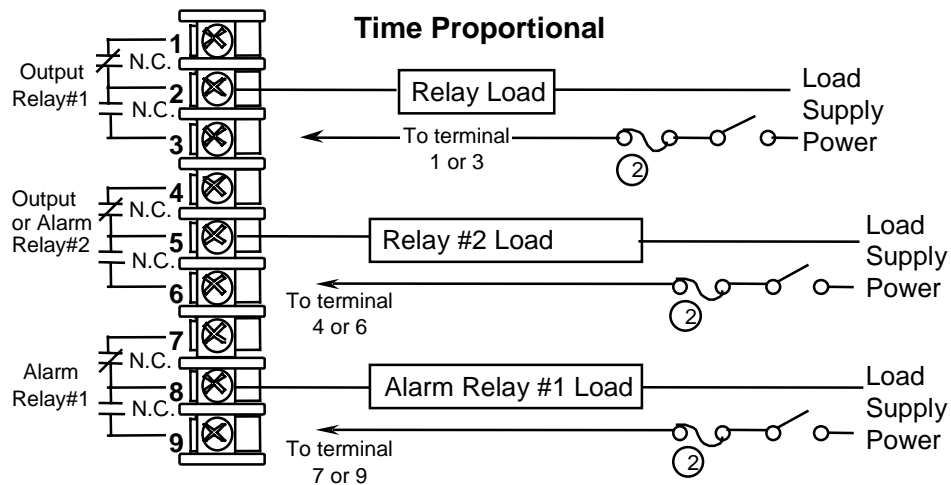

- ① Alarm #2 is not available with Time Proportional Duplex or Three Position Step Control or Position Proportional Control.
- ② Electromechanical relays are rated at 5 Amps @ 120 Vac or 30 Vdc and 2.5 Amps at 240 Vac.

Customer should size fuses accordingly. Use FastBlo fuses only.

**Figure 2-7 Electromechanical Relay Output – Model DC330X-EE-XXX**

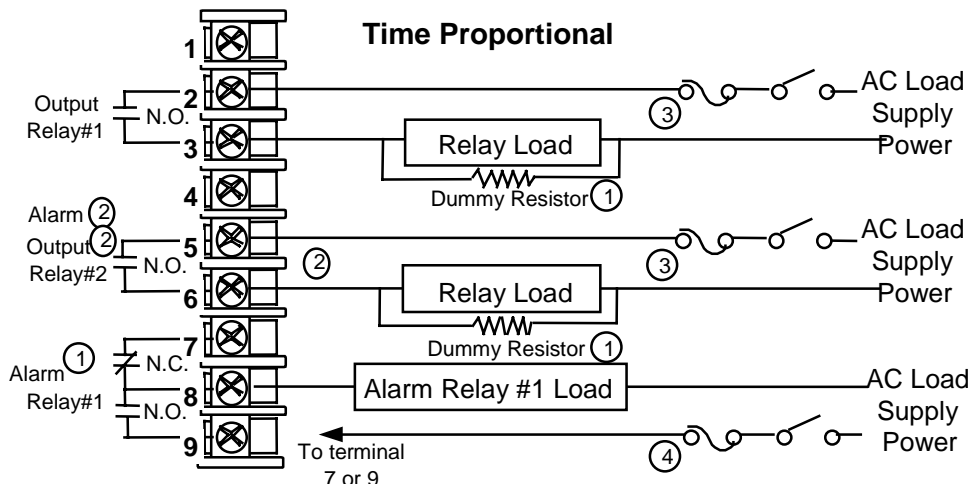

- ① If the load current is less than the minimum rated value of 20mA, there may be a residual voltage across both ends of the load even if the relay is turned off. Use a dummy resistor as shown to counteract this. The total current through the resistor and the load current must exceed 20mA.
- ② Alarm #2 not available with Time Proportional Duplex or Three Position Step Control or Position Proportional control.
- ③ Solid State relays are rated at 0.5 amps. Customer should size fuses accordingly. Use FastBlo fuses only.
- ④ Electromechanical relays are rated at 5 Amps @ 120 Vac or 30 Vdc and 2.5 Amps at 240 Vac. Customer should size fuses accordingly. Use Fast Blo fuses only.

**WARNING: Only connect Vac to solid state relays.**

**Figure 2-8 Solid State (SS) Relay Output — Model DC33-X-AA-XX**

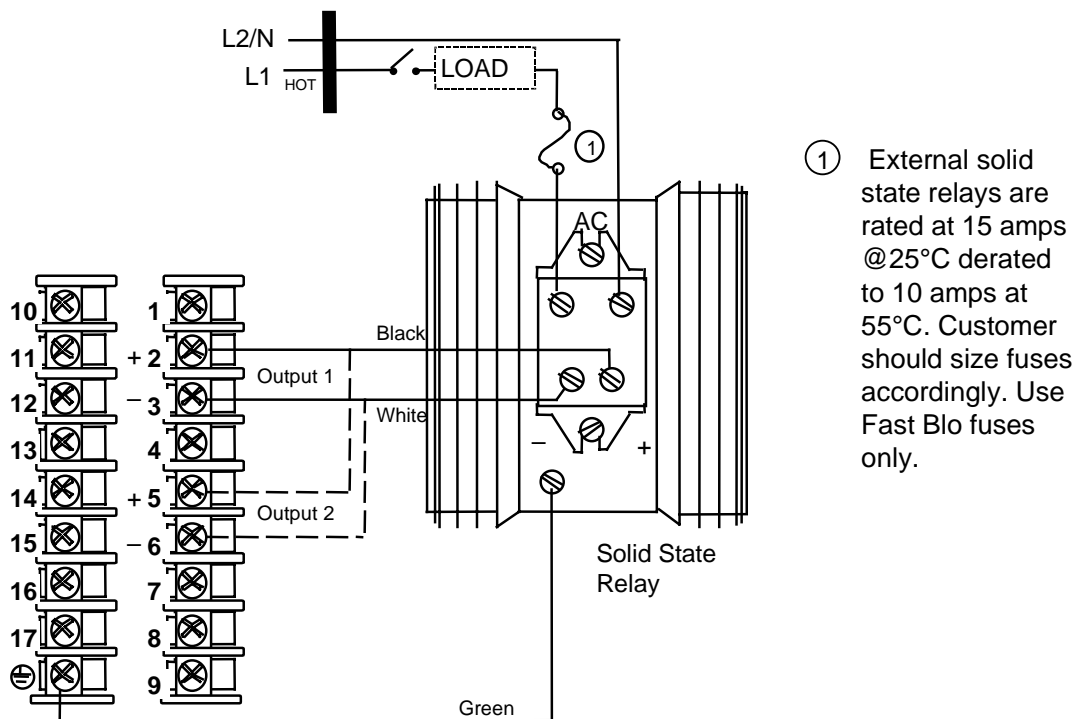

- ① External solid state relays are rated at 15 amps @ 25°C derated to 10 amps at 55°C. Customer should size fuses accordingly. Use Fast Blo fuses only.

**Figure 2-9 10-amp SS External Relay Output — Model DC330X-SS-XX**

### Time Proportional Simplex

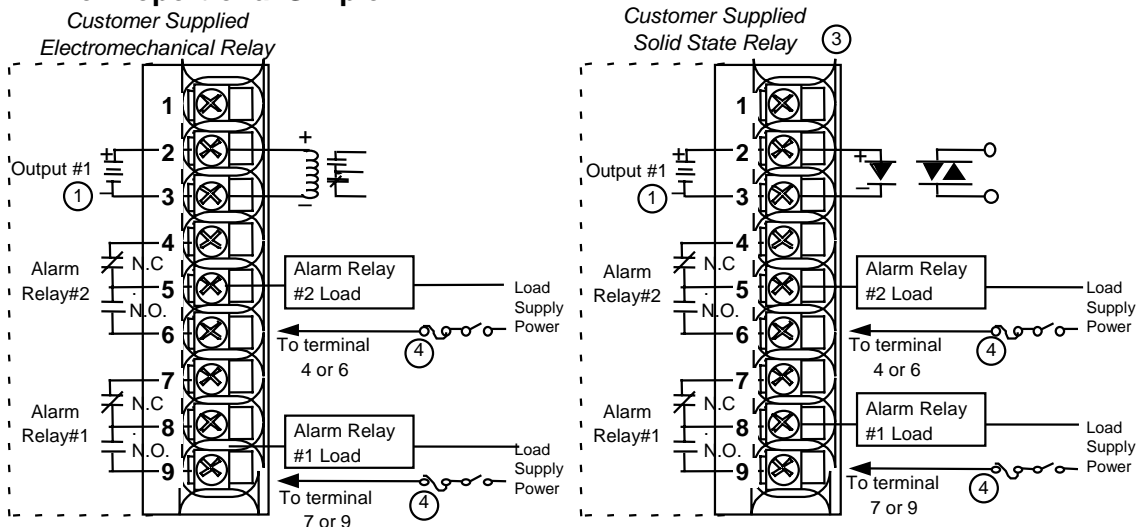

### Time Proportional Duplex

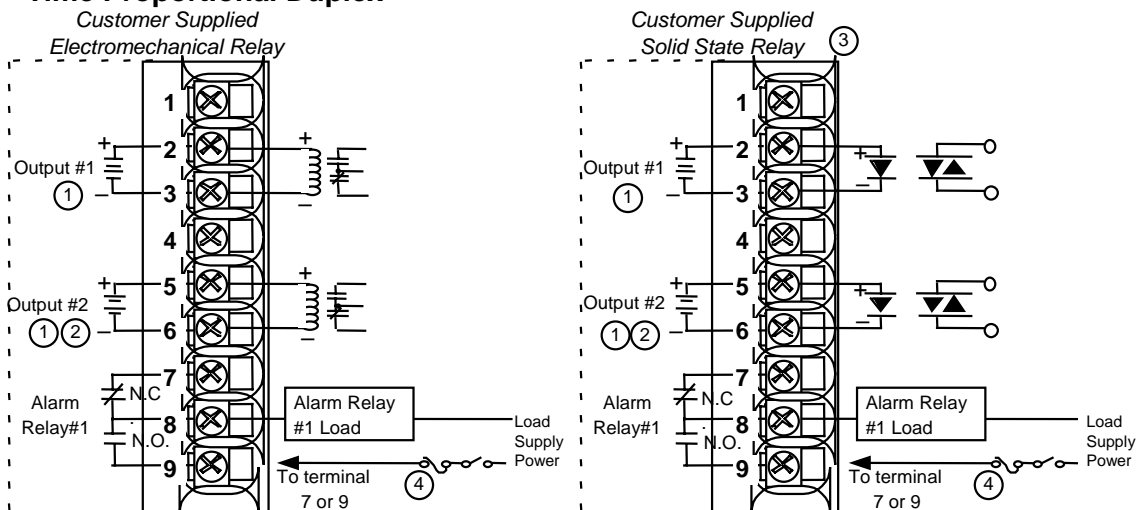

- ① **CAUTION** Open collector outputs are internally powered. Connecting an external supply will damage the controller.
- ② Alarm #2 not available with Time Proportional Duplex or Three Position Step Control or Position Proportional control.
- ③ Can also use 10 amp solid state relay, Part Number 30756018-003
- ④ Electromechanical relays are rated at 5 Amps @ 120 Vac or 30 Vdc and 2.5 Amps at 240 Vac. Customer should size fuses accordingly. Use Fast Blo fuses only.

24166

**Figure 2-10 Open Collector Output — Model DC330X-TT-XXX**

### Current Output/Universal Output

Figure 2-11 shows the Output and Alarm wiring connections for models with Current Output and two-relay outputs (**Model DC330X-KE-XXX**).

See Table 2-3 for relay terminal connections for Output Algorithm selected.

For Duplex Current Output use Auxiliary Output for Output 2 (cool) (see Figure 2-14).

**ATTENTION:**  
All current outputs are isolated from each other, case ground, and all inputs.

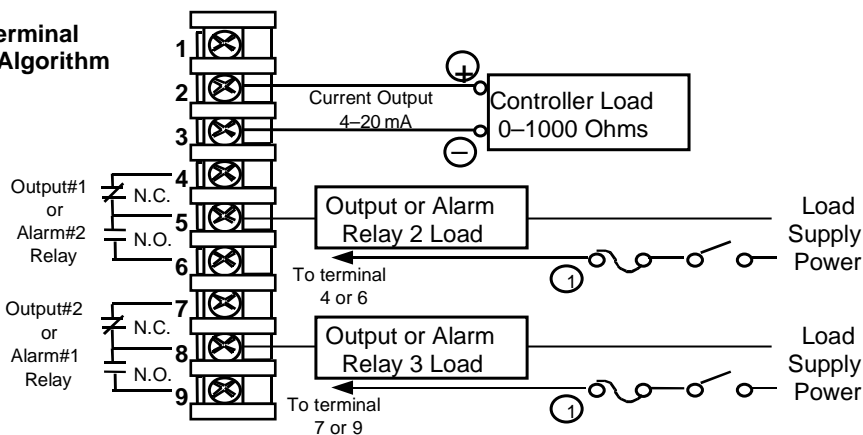

- ① Electromechanical relays are rated at 5 Amps @ 120 Vac or 2.5 Amps at 240 Vac. Customer should size fuses accordingly. Use Fast Blo fuses only. Relays are NOT available on DC330X-C0-XXX.

**Figure 2-11 Current Output Current/Time Duplex, Time/Current Duplex, Position Proportional or Three Position Step Control**

Figure 2-12 shows the Output and Alarm wiring connections for models with a Current Output (Auxiliary Output) and three Relay Outputs (**Model DC330X-EE-2XX**).

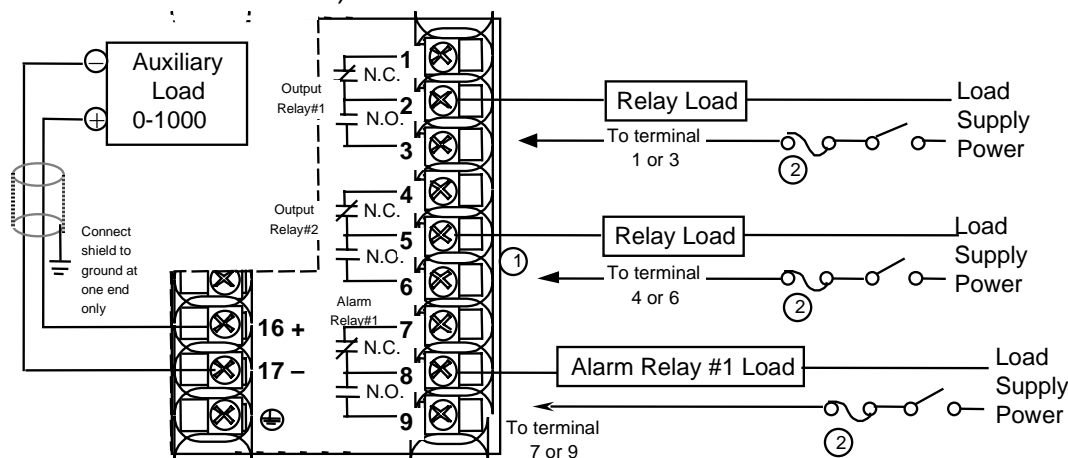

- ① Alarm #2 is not available with Time Proportional Duplex or Three Position Step Control or Position Proportional Control.
- ② Electromechanical relays are rated at 5 Amps @ 120 Vac or 2.5 Amps at 240Vac. Customer should size fuses accordingly. Use Fast Bio fuses only.

**All current outputs are isolated from each other, case ground, and all inputs.**

**Figure 2-12 Auxiliary Output and Three-Relay Output**

### Position Proportional Output

Figure 2-13 shows models with Position Proportional Output (**Model DC330X-EE-XXX-X2**) or Three Position Step Control (**Model DC330X-AA-XXX-X2**).

#### Calibration

Position Proportional Output models must have the output calibrated after installation.

Three Position Step models only require that the motor time be entered. Full calibration is not required.

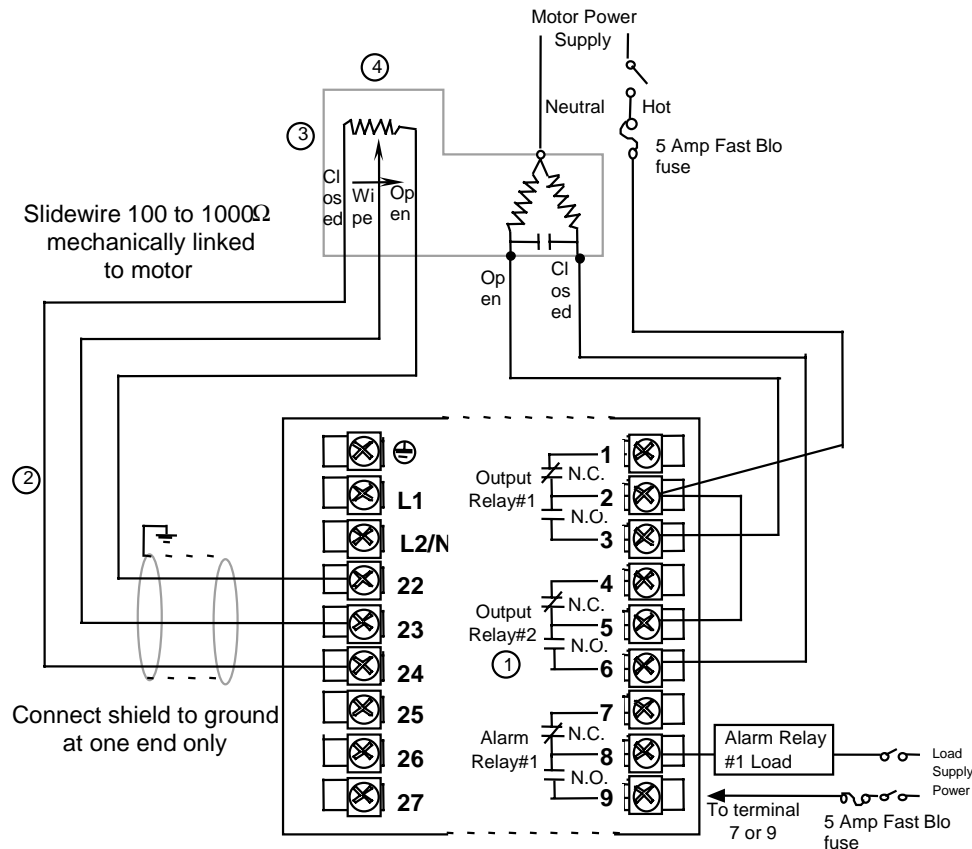

- ① Alarm #2 is not available with Position Proportional output or Three Position Step control.
- ② Do not run slidewire cable in the same conduit as AC power.
- ③ Electrical noise suppression may be required.
- ④ Slidewire input is not required for Three Position Step control but can be used for motor position indication.

**Figure 2-13 Position Proportional Output or Three Position Step—Models DC330X-EE-XXX-X2, DC330X-AA-XXX-X2**

### Auxiliary Output

For Duplex Current Output use Control Output for Output 1 (heat)

**ATTENTION:**  
Both current outputs (control and auxiliary) are isolated from each other, case ground, and all inputs.

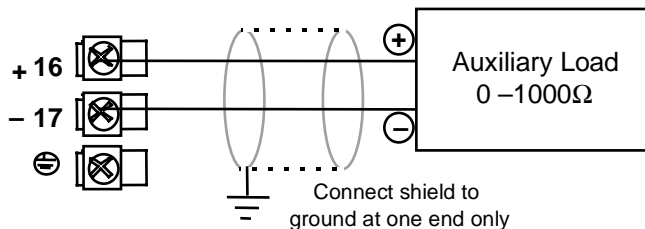

**Figure 2-14 Auxiliary Output Connections—  
Models DC330X-XX-2XX, DC330X-XX-5XX**

### Digital Inputs

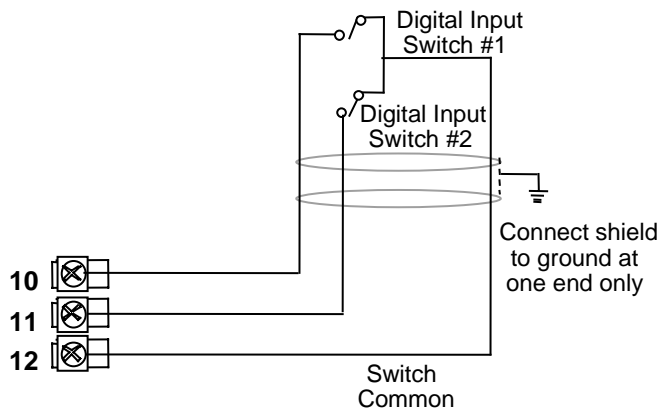
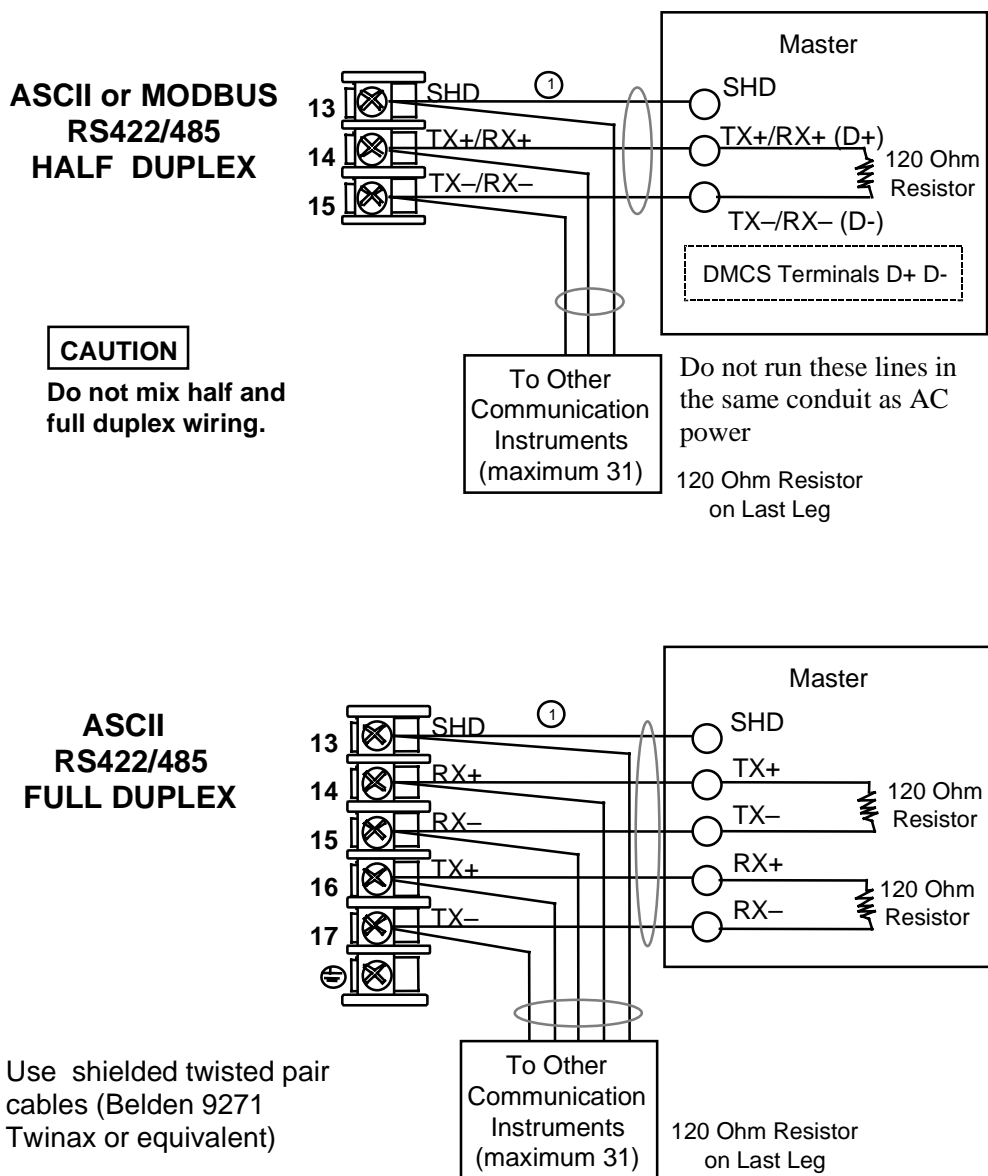

**Figure 2-15 Digital Inputs Connections—Model DC330X-XX-XX3**

### Communications Option

There are two types of Communications option available:

- RS422/485/ASCII or Modbus (**Model DC330X-XX-1XX** or **DC330X-XX-5XX**)—Figure 2-16
- DMCS (**Model DC330X-XX-4XX**)—Figure 2-16

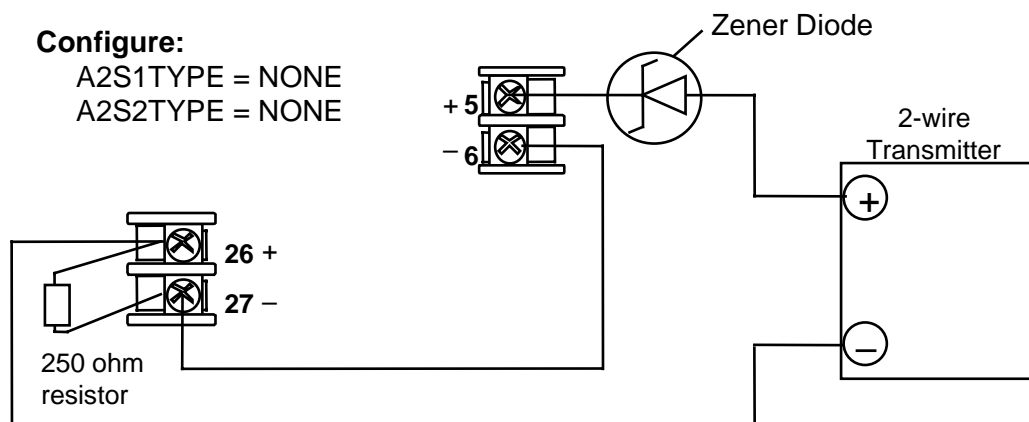

**Figure 2-16 RS422/485/ASCII or Modbus Communications Option Connections**



### Transmitter power for 4-20 mA 20 Wire Transmitter— Using Open Collector Alarm 2 Output

The wiring diagram example shown in Figure 2-17 (**Model DC330X-XT-XXX**) provides 30 Vdc at terminals 5 and 6 with the capability of driving up to 22 mA. If the transmitter terminal voltage must be limited to less than 30 volts, you can insert a zener diode between the positive transmitter terminal and terminal 5. For example, an IN4733A zener diode will limit the voltage at the transmitter to 25 Vdc.

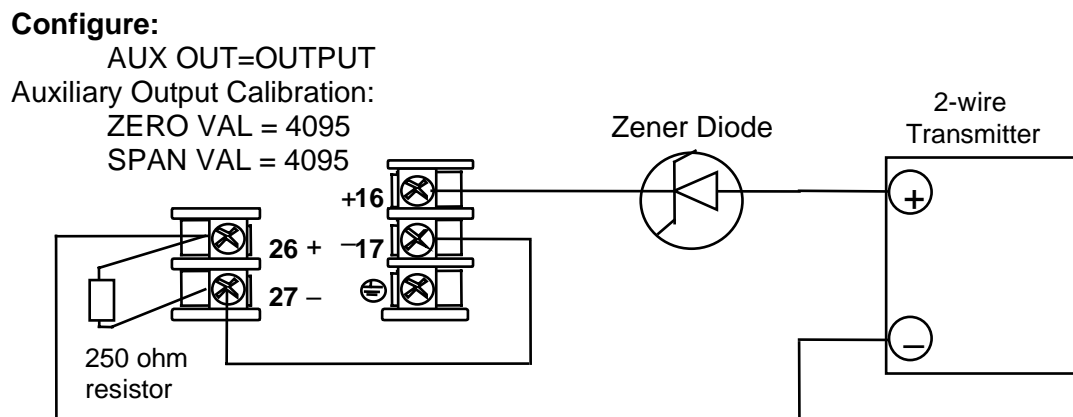

**Figure 2-17 Transmitter Power for 4-20 mA 2-wire Transmitter Using Open Collector Alarm 2 Output—Model DC330X-XT-XXX**

### Transmitter power for 4-20 mA 20 wire Transmitter—Using Auxiliary Output

The wiring diagram example shown in Figure 2-18 (**Model DC330X-XX-2XX or DC330X-XX-5XX**) provides 30 Vdc at terminal 16 with the capability of driving up to 22 mA.

If the transmitter terminal voltage must be limited to less than 30 volts, you can insert a zener diode between the positive transmitter terminal and terminal 16. For example, an IN4733A zener diode will limit the voltage at the transmitter to 25 Vdc.



**Figure 2-18 Transmitter Power for 4-20 mA 2-wire Transmitter Using Auxiliary Output—Model DC330X-XX-2XX or DC330X-XX-5XX**

## Control Relays

**ATTENTION**

Control relays operate in the standard control mode: i.e., energized when output state is on.

**Table 2-3 Control Relay Contact Information**

Unit Power	Control Relay Wiring	Control Relay Contact	#1 or #2 Output Indicator Status
Off	N.O.	Open	Off
	N.C.	Closed	
On	N.O.	Open Closed	Off On
	N.C.	Closed Open	Off On

## Alarm Relays

**ATTENTION**

Alarms relays are designed to operate in a failsafe mode; i.e., de-energized during alarm state. This results in alarm actuation when power is OFF or when initially applied, until the unit completes self-diagnostics. If the unit loses power, the alarms will function.

**Table 2-4 Alarm Relay Contact Information**

Unit Power	Alarm Relay Wiring	Variable NOT in Alarm State		Variable in Alarm State	
		Relay Contact	Indicators	Relay Contact	Indicators
Off	N.O.	Open	Off	Open	Off
	N.C.	Closed		Closed	
On	N.O.	Closed	Off	Open	On
	N.C.	Open		Closed	

### 3. Configuration

#### 3.1 Overview

The controller is pre-configured at the factory for typical controller settings for a heating process except the input type and output algorithm must be configured to match your process. The controller must also be tuned. See *Section 4.3*.

To assist you in the configuration process, there are prompts that appear in the upper and lower displays. These prompts let you know what group of configuration data (Set Up prompts) you are working with and also, the specific parameters (Function prompts) associated with each group.

Figure 3-1 shows you an overview of the prompt hierarchy. As you will see, the configuration data is divided into 15 main Set Up groups plus prompts for calibration and prompts that show the status of the continuous background tests that are being performed.

**Figure 3-1 Prompt Hierarchy**

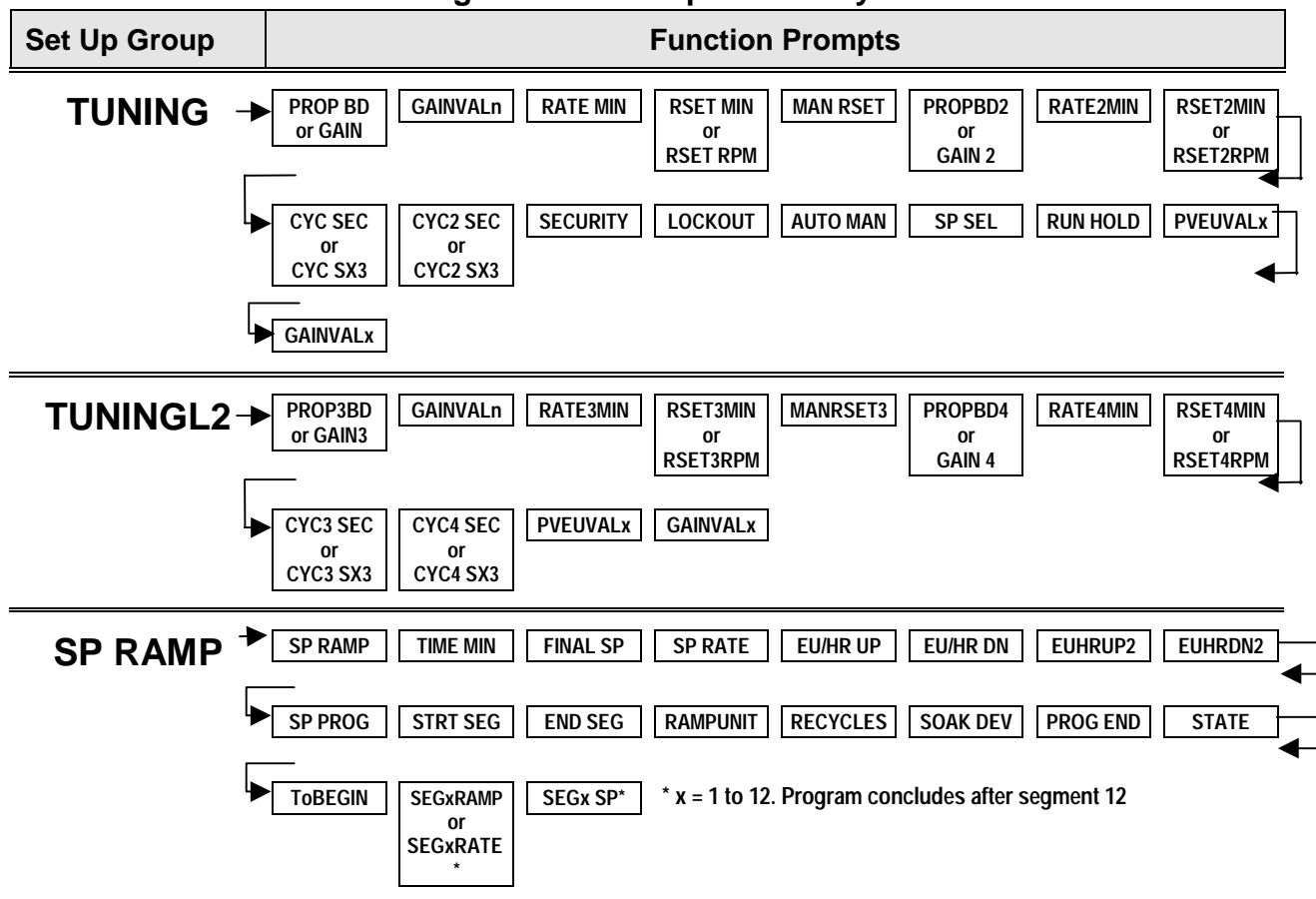

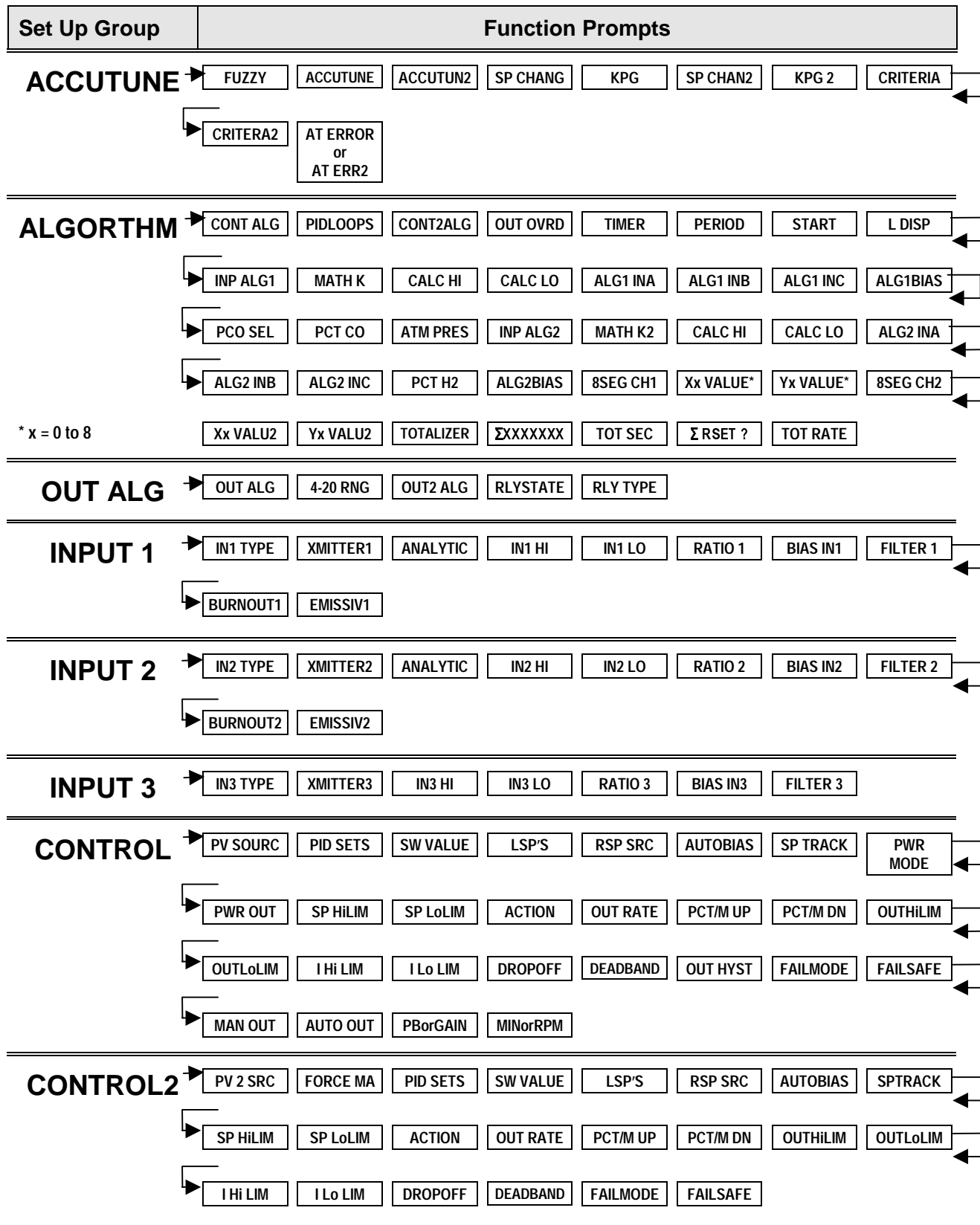

Set Up Group	Function Prompts
<b>OPTIONS</b>	→ AUX OUT or CUR OUT2    4 mA VAL    20mA VAL    DIG IN 1    DIG1 COM    DIG IN 2    DIG2 COM
<b>COM</b>	→ ComSTATE    Com ADDR    ComADDR2    SHEDENAB    SHEDTIME    PARITY    BAUD    DUPLEX ↳ WSFLOAT    TX DELAY    SHEDMODE    SHEDSP    UNITS    CSP RATO    CSP BIAS    CSP2RATO ↳ CSP2BIAS    LOOPBACK
<b>ALARMS</b>	→ A1S1 VAL    A1S2 VAL    A2S1 VAL    A2S2 VAL    A1S1TYPE    A1S2 TYPE    A2S1TYPE    A2S2TYPE ↳ A1S1 H L    A1S1 EV    A1S2 H L    A1S2 EV    A2S1 H L    A2S1 EV    A2S2 H L    A2S2 EV ↳ AL HYST    ALM OUT1    BLOCK
<b>DISPLAY</b>	→ DECIMAL    DECIMAL2    TEMPUNIT    PWR FREQ    RATIO 2    LANGUAGE
<b>CALIB</b>	→ USED FOR FIELD CALIBRATION
<b>MAINTNCE</b>	TIME1    HRS.MIN1    TIME2    HRS.MIN2    TIME3    HRS.MIN3    COUNTER1    COUNTS1 COUNTER2    COUNTS2    COUNTER3    COUNTS3    PASSWORD    RES TYPE
<b>STATUS</b>	→ VERNON    FAILSAFE    FAILSF 2    RAM TEST    CONFTEST    CALTEST    FACT CRC

### 3.2 Configuration Procedure

Each of the Set Up groups and their functions are pre-configured at the factory. The factory settings are shown in Table 3-2 through Table 3-16. Follow the procedure in Table 3-1 if you want to make changes to any of these selections or values. Record your selections on the Configuration Record Sheet found in Appendix C.

**Table 3-1 Configuration Procedure**

Step	Operation	Press	Result
1	Select Set Up mode	<b>SET UP</b>	<i>Upper Display:</i> SET UP <i>Lower Display:</i> TUNING (This is the first Set Up group title.)
2	Select any Set Up group	<b>SET UP</b>	Sequentially displays the other Set Up group titles. You can also use the [▲] [▼] keys to scan the Set Up groups in both directions. Stop at the Set Up group title that describes the group of parameters you want to configure. Then proceed to the next step.
3	Select a Function parameter	<b>FUNCTION</b>	<i>Upper Display:</i> Shows the current value or selection for the first Function prompt of the selected Set Up group. <i>Lower Display:</i> Shows the first Function prompt within that Set Up group.  Sequentially displays the other function prompts of the selected Set Up group. Stop at the function prompt that you want to change, then proceed to the next step.
4	Change the value or selection	<b>▲ or ▼</b>	Increments or decrements the value or selection that appears for the selected function.  If the display flashes, you are trying to make an unacceptable entry.
5	Enter the value or selection	<b>FUNCTION or SET UP</b>	This key selects another Function prompt.  This key selects another Set Up group.  The value or selection you have made will be entered into memory after another key is pressed.
6	Exit Configuration	<b>LOWER DISPLAY</b>	Exits configuration mode and returns the controller to the same state it was in immediately preceding entry into the Set Up mode. It stores any changes you have made.

### 3.3 Loop 1 Tuning Parameters Set Up Group

Table 3-2 Loop 1 Tuning Group Function Prompts

Function Prompt Lower Display	Function Name	Selections or Range of Setting Upper Display	Factory Setting
<b>PROP BD</b> or <b>GAIN</b>	Proportional Band or Gain	0.1 to 9999%  0.001 to 1000	--  1.000
or <b>GAINVALn</b>	Or Gain Value being used by <b>Gain Scheduling</b> when enabled	Read Only	--
<b>RATE MIN</b>	Rate in Minutes	0.00 to 10.00 minutes	0.00
<b>RSET MIN</b> or <b>RSET RPM</b>	Reset in minutes/repeat or Reset in repeats/minute	0.02 to 50.00	1.00  --
<b>MAN RSET</b>	Manual Reset	-100 to 100% output	0
<b>PROPBD2</b> or <b>GAIN 2</b>	Proportional Band 2 or Gain 2	0.1 to 9999%  0.001 to 1000	--  1.000
<b>RATE2MIN</b>	Rate 2 in Minutes	0.00 to 10.00 minutes	0.00
<b>RSET2MIN</b> or <b>RSET2RPM</b>	Reset 2 in minutes/repeat or Reset 2 in repeats/minute	0.02 to 50.00	1.00  --
<b>CYC SEC</b> or <b>CYC SX3</b>	Cycle Time (Heat)	1 to 120	20
<b>CYC2 SEC</b> or <b>CYC2 SX3</b>	Cycle Time (Cool)	1 to 120	20
<b>SECURITY</b>	Security Code	0 to 4095	0

## Configuration

---

Function Prompt Lower Display	Function Name	Selections or Range of Setting Upper Display	Factory Setting
<b>LOCKOUT</b>	Configuration Lockout	NONE CALIB + CONF + VIEW MAX	CALIB
<b>AUTO MAN</b>	Manual/Auto Key Lockout	DISABL ENABLE	ENABLE
<b>SP SEL</b>	Setpoint Select Key Lockout	DISABL ENABLE	ENABLE
<b>RUN HOLD</b>	Run/Hold Key Lockout	DISABL ENABLE	ENABLE
<b>PVEUVAL1</b> <b>PVEUVAL2</b> <b>PVEUVAL3</b> <b>PVEUVAL4</b> <b>PVEUVAL5</b> <b>PVEUVAL6</b> <b>PVEUVAL7</b> <b>PVEUVAL8</b>	PV1 (through PV8) Value for Gain Scheduling	PV value within the PV limits. In engineering units	0
<b>GAINVAL1</b> <b>GAINVAL2</b> <b>GAINVAL3</b> <b>GAINVAL4</b> <b>GAINVAL5</b> <b>GAINVAL6</b> <b>GAINVAL7</b> <b>GAINVAL8</b>	Gain 1 (through Gain 8) Value for Gain Scheduling	0.001 to 1000 floating Gain or Proportional Band	1.000

---



### 3.4 Loop 2 Tuning Parameters Set Up Group

Table 3-3 Loop 2 Tuning Group Function Prompts

Function Prompt Lower Display	Function Name	Selections or Range of Setting Upper Display	Factory Setting
<b>PROPBD3</b> or <b>GAIN 3</b>	Proportional Band 3 or Gain 3	0.1 to 9999  0.001 to 1000	--  1.000
or <b>GAINVALn</b>	or Gain Value being used by <b>Gain Scheduling</b> when enabled	Read Only	--
<b>RATE3MIN</b>	Rate 3 in minutes	0.00 to 10.00 minutes	0.00
<b>RSET3MIN</b> or <b>RSET3RPM</b>	Reset 3 in minutes/repeat or Reset 3 in repeats/minute	0.02 to 50.00	1.00  --
<b>MANRSET3</b>	Manual Reset 3	-100 to 100% Output	0.0
<b>PROPBD4</b> or <b>GAIN 4</b>	Proportional Band 4 or Gain 4	0.1 to 9999%  0.001 to 1000	--  1.000
<b>RATE4MIN</b>	Rate 4 in minutes	0.00 to 10.00 minutes	0.00
<b>RSET4MIN</b> or <b>RSET4RPM</b>	Reset 4 in minutes/repeat or Reset 4 in repeats/minute	0.02 to 50.00	1.00  --
<b>CYC3 SEC</b> or <b>CYC3 SX3</b>	Cycle Time 3 (Heat)	1 to 120	20
<b>CYC4 SEC</b> or <b>CYC4 SX3</b>	Cycle Time 4 (Cool)	1 to 120	20

**Configuration**

---

<b>Function Prompt Lower Display</b>	<b>Function Name</b>	<b>Selections or Range of Setting Upper Display</b>	<b>Factory Setting</b>
<b>PVEUVAL1</b> <b>PVEUVAL2</b> <b>PVEUVAL3</b> <b>PVEUVAL4</b> <b>PVEUVAL5</b> <b>PVEUVAL6</b> <b>PVEUVAL7</b> <b>PVEUVAL8</b>	PV1 (through PV8) Value for Gain Scheduling	PV value within the PV limits. In engineering units	0
<b>GAINVAL1</b> <b>GAINVAL2</b> <b>GAINVAL3</b> <b>GAINVAL4</b> <b>GAINVAL5</b> <b>GAINVAL6</b> <b>GAINVAL7</b> <b>GAINVAL8</b>	Gain 1 (through Gain 8) Value for Gain Scheduling	0.001 to 1000 floating Gain or Proportional Band	1.000

---

### 3.5 SP Ramp, SP Rate, or SP Programming Set Up Group

**Table 3-4 SP Ramp Function Prompts**

Function Prompt	Function Name	Selections or Range of Setting	Factory Setting
Lower Display		Upper Display	
<b><i>If SP Rate and SP Programming are disabled</i></b>			
<b>SP RAMP</b>	Single Setpoint RampSelection	DISABL ENABLE ENABL2 ENAB12	DISABL
<b>TIME MIN</b>	Single Setpoint Ramp Time (SP Ramp enabled)	0 to 255 minutes	3
<b>FINAL SP</b>	Sinlge Setpoint Final Setpoint (SP Ramp enabled)	Enter a value within the setpoint limits.	1000
<b><i>If SP Ramp and SP Programming are disabled</i></b>			
<b>SP RATE</b>	Setpoint Rate	DISABL ENABLE ENABL2 ENAB12	DISABL
<b>EU/HR UP</b>	Rate Up Value for Loop 1 (SP Rate enabled)	0 to 9999 in engineering units per hour	0
<b>EU/HR DN</b>	Rate Down Value for Loop 1 (SP Rate enabled)	0 to 9999 in engineering units per hour	0
<b>EU/HRUP2</b>	Rate Up Value for Loop 2 (SP Rate enabled)	0 to 9999 in Units per Hour	0
<b>EU/HRDN2</b>	Rate Down Value for Loop 2 (SP Rate enabled)	0 to 9999 in Units per Hour	0
<b><i>If SP Ramp and SP Rate are disabled</i></b>			
<b>SP PROG*</b>	Setpoint Ramp/Soak Programming	DISABL ENABLE ENABL2 ENAB12	DISABL
<b>*requires SP Program option</b>		<b>SP PROG must be enabled to view the remaining prompts.</b>	
<b>STRT SEG</b>	Start Segment Number	1 to 11	—
<b>END SEG</b>	End Segment Number	2 to 12 Always end in a soak segment (2, 4, ... 12)	—

## Configuration

Function Prompt Lower Display	Function Name	Selections or Range of Setting Upper Display	Factory Setting
<b>RAMPUNIT</b>	Engineering Units for Ramp Segments	TIME (hours.minutes) EU/MIN (engineering units/minute) EU/HR (engineering units/hour)	TIME
<b>RECYCLES</b>	Number of Program Recycles	0 to 99 recycles	—
<b>SOAK DEV</b>	Guaranteed Soak Deviation Value	0 to 99 The number selected will be the PV value (in engineering units) above or below the setpoint outside of which the timer halts.	—
<b>PROG END</b>	Program Termination State	LASTSP (Hold at last setpoint in the program) F SAFE (Manual mode/Failsafe output)	—
<b>STATE</b>	Program State at Program End	DISABL HOLD	—
<b>KEYRESET</b>	Reset SP Program	DISABL TOBEGN RERUN	DISABL
<b>HOT START</b>	Hot Start	DISABL ENAB	DISABL
<b>SEG1RAMP</b> or <b>SEG1RATE</b>	Segment #1 Ramp Time or Segment #1 Ramp Rate	0-99 hours.0-59 minutes Engineering units/minute or Engineering units/hour  <b>Select TIME, EU/MIN, or EU/HR at prompt RAMPUNIT. All ramps will use the same selection.</b>	—
<b>SEG2 SP</b>	Segment #2 Soak Setpoint Value	Within the Setpoint limits	—
<b>SEG2TIME</b>	Segment #2 Soak Duration	0-99 hours.0-59 minutes	—

Function Prompt Lower Display	Function Name	Selections or Range of Setting Upper Display	Factory Setting
SEG 3, 5, 7, 9 & 11 RAMP	Same as above	Selections are same as above.	—
SEG 3, 5, 7, 9, & 11 RATE			
SEG 4, 6, 8, 10 & 12 SP			
SEG 4, 6, 8, 10 & 12 TIME			

### 3.6 Accutune Set Up Group

Table 3-5 Accutune Group Function Prompts

Function Prompt Lower Display	Function Name	Selections or Range of Setting Upper Display	Factory Setting
<b>FUZZY</b>	Fuzzy Overshoot Suppression	DISABL ENABLE ENABL2 ENAB12	DISABL
<b>ACCUTUNE</b>	Accutune	DISABL TUNE (Demand Tuning) SP (SP Tuning) TUN+PV SP+PV	DISABL
<b>ACCUTUN2</b>	Accutune – Loop 2	DISABL TUNE (Demand Tuning) SP (SP Tuning) TUN+PV SP+PV	DISABL
<b>SP CHANG</b>	Setpoint Change Value – Loop 1	5 to 15% Input Span	10
<b>KPG</b>	Process Gain – Loop 1	0.10 to 10.00	1.00
<b>SP CHAN2</b>	Setpoint Change Value – Loop 2	5 to 15% Input Span	10
<b>KPG 2</b>	Process Gain – Loop 2	0.10 to 10.00	1.00
<b>CRITERIA</b>	Tuning Criteria – Loop 1	NORMAL FAST	FAST

Function Prompt Lower Display	Function Name	Selections or Range of Setting Upper Display	Factory Setting
<b>CRITERA2</b>	Tuning Criteria – Loop 2	NORMAL FAST	FAST
<b>AT ERROR</b> OR <b>AT ERR2</b>	Accutune Error Codes	Read Only RUNING (Accutune process in operation) NONE OUTLIM IDFAIL ABORT LOW PV	--

### 3.7 Algorithm Data Set Up Group

**Table 3-6 Algorithm Group Function Prompts**

Function Prompt Lower Display	Function Name	Selections or Range of Setting Upper Display	Factory Setting
<b>CONT ALG</b>	Control Algorithm	ON-OFF PID A PID B PD+MR 3PSTEP	PID A
<b>PIDLOOPS</b>	PID Loop Selection	1 LOOP 2LOOPS CASCAD	1 or 2
<b>CONT2ALG</b>	Control 2 Algorithm	PID A PID B PD+MR	PID A
<b>OUT OVRD</b>	Output Override Select	DISABL HI SEL LO SEL	DISABL
<b>TIMER</b>	Timer Enable/Disable	ENABLE DISABL	DISABL
<b>PERIOD*</b>	Timeout Period	00:00 to 99:59	00:01
<b>START*</b>	Start Initiation	KEY (Run/Hold key) ALARM2	KEY
<b>L DISP*</b>	Lower Display Selection	TI REM (time remaining) E time (elapsed time)	TI REM

\*prompts appear only when Timer is enabled

Function Prompt Lower Display	Function Name	Selections or Range of Setting Upper Display		Factory Setting
<b>INP ALG1</b>	Input 1 Algorithm <b>ATTENTION</b> All Input Algorithms operate in engineering units except feedforward which operates in percent of output units. PV or RSP source in the Control Set Up group must be set to IN AL1.	NONE W AVG F FWRD FFWDMu RELHUM SUMMER HI SEL LO SEL √MuDIV √MULT	MuDIV MULT CARB A CARB B CARB C CARB D FCC DEW PT OXYGEN	NONE
<b>MATH K</b>	Weighted Average Ratio or K Constant for Math Selections	0.001 to 1000 floating		--
<b>CALC HI</b>	Calculated Variable High Scaling Factor for Input Algorithm	-999. to 9999. floating (in engineering units)		--
<b>CALC LO</b>	Calculated Variable Low Scaling Factor for Input Algorithm	-999. to 9999. floating (in engineering units)		--
<b>ALG1 INA</b>	Input Algorithm 1 Input A Selection	INPUT 1 INPUT 2 LP1OUT LP2OUT	IN AL1 IN AL2 INPUT 3	--
<b>ALG1 INB</b>	Input Algorithm 1 Input B Selection	INPUT 1 INPUT 2 LP1OUT LP2OUT	IN AL1 IN AL2 INPUT 3	--
<b>ALG1 INC</b>	Input Algorithm 1 Input C Selection	NONE INPUT 1 INPUT 2 LP1OUT	LP2OUT IN AL1 IN AL2 INPUT 3	--
<b>PCO SEL</b>	Percent Carbon Source (Input 3 must be enabled)	DISABL ONLINE		DISABL
<b>PCT CO</b>	Percent Carbon Monoxide	0.020 to 0.350 (fractional percent of CO)		0.200
<b>ATM PRES</b>	Atmospheric Pressure Compensation	590.0 to 760.0 (mm Hg)		760.0
<b>ALG1BIAS</b>	Input Algorithm 1 Bias	-999 to 9999 floating (in engineering units)		0.000

Function Prompt Lower Display	Function Name	Selections or Range of Setting Upper Display		Factory Setting
<b>INP ALG2</b>	Input 2 Algorithm <b>ATTENTION</b> All Input Algorithms operate in engineering units except feedforward which operates in percent of range units.	NONE W AVG F FWD FFWDMu A-B/C HI SEL	LO SEL √MuDIV √MULT MuDIV MULT DEW PT	NONE
<b>MATH K2</b>	Weighted Average Ratio or K Constant for Math Selections	0.001 to 1000		--
<b>CALC HI</b>	Calculated Variable High Scaling Factor for Input Algorithm 2	-999. to 9999. floating (in engineering units)		--
<b>CALC LO</b>	Calculated Variable Low Scaling Factor for Input Algorithm 2	-999. to 9999. floating (in engineering units)		--
<b>ALG2 INA</b>	Input Algorithm 2 Input A Selection	INPUT 1 INPUT 2 LP1OUT LP2OUT	IN AL1 IN AL2 INPUT 3	--
<b>ALG2 INB</b>	Input Algorithm 2 Input B Selection	INPUT 1 INPUT2 LP1OUT LP2OUT	IN AL1 IN AL2 INPUT 3	--
<b>ALG2 INC</b>	Input Algorithm 2 Input C Selection	NONE INPUT 1 INPUT 2 LP1OUT	LP2OUT IN AL1 IN AL2 INPUT 3	--
<b>PCT H2</b>	Hydrogen Content for Dewpoint	1.0 to 99.0%		1.0
<b>ALG2BIAS</b>	Input Algorithm 2 Bias	-999 to 9999 floating (in engineering units)		0.000
<b>8SEG CH1</b>	Eight Segment Characterizer <b>If Characterizer 1 is enabled, the following Xn VALUE and Yn VALUE parameters appear.</b>	DISABL INPUT1 INPUT2 L1 OUT L2 OUT		DISABL



Function Prompt Lower Display	Function Name	Selections or Range of Setting Upper Display	Factory Setting
X0 VALUE X1 VALUE X2 VALUE X3 VALUE X4 VALUE X5 VALUE X6 VALUE X7 VALUE X8 VALUE	Xn Input Value (X Axis) (n = 0 through 8)	0 to 99.99 %	0
Y0 VALUE Y1VALUE Y2VALUE Y3VALUE Y4VALUE Y5VALUE Y6VALUE Y7VALUE Y8 VALUE	Yn Output Value (Y Axis) (n = 0 through 8)	0 to 99.99 %	0
8SEG CH2	Eight Segment Characterizer 2  <b>If Characterizer 2 is enabled, the following Xn VALU2 and Yn VALU2 parameters appear.</b>	DISABL INPUT1 INPUT2 L1 OUT L2 OUT	DISABL
X0 VALU2 X1 VALU2 X2 VALU2 X3 VALU2 X4 VALU2 X5 VALU2 X6 VALU2 X7 VALU2 X8 VALU2	Xn Input Value (X Axis) (n = 0 through 8)	0 to 99.99%	0
Y0 VALU2 Y1 VALU2 Y2 VALU2 Y3 VALU2 Y4 VALU2 Y5 VALU2 Y6 VALU2 Y7 VALU2 Y8 VALU2	Yn Output Value (Y Axis) (n = 0 through 8)	0 to 99.99 %	0

## Configuration

Function Prompt Lower Display	Function Name	Selections or Range of Setting Upper Display	Factory Setting
<b>TOTALIZE</b>	Totalization Function	DISABL INPUT1 IN AL1 IN AL2	DISABL
<b>ΣXXXXXXX</b>	Current Scale Factor <i>(upper display)</i> Actual Current Totalized Value <i>(lower display)</i>	Σ*En  Where: n = Totalizer Scale Factor Value	--
<b>TOT SCAL</b>	Totalizer Scale Factor	*E0 *E1 *E2 *E3 *E4 *E5 *E6	E0
<b>TOT SEC</b>	Totalizer Reset Lock	UNLOCK LOCK	UNLOCK
<b>Σ RSET ?</b>	Totalizer Reset	NO YES	NO
<b>TOT RATE</b>	Totalizer Rate of Integration	SECOND (once per second) MINUTE (once per minute) HOUR (once per hour) DAY (once per day) ML/DAY (millions per day)	SECOND

## 3.8 Output Algorithm Parameters Set Up Group

Table 3-7 Output Algorithm Group Function Prompts

Function Prompt Lower Display	Function Name	Selections or Range of Setting Upper Display	Factory Setting
<b>OUT ALG</b>	Loop 1 Output Algorithm	TIME Time Simplex CURRNT Current Simplex POSITN Position Proportional TIME D Time Duplex CUR D Current Duplex CUR TI Current /Time Duplex TI CUR Time/Current Duplex	CURRNT
<b>4-20 RNG</b>	Current Duplex Range	100PCT 50 PCT	100PCT

Function Prompt Lower Display	Function Name	Selections or Range of Setting Upper Display	Factory Setting
<b>OUT2 ALG</b>	Loop 2 Output Algorithm	NONE TIME CURRNT CUR D CUR TI TI CUR	CURRNT
<b>RLYSTATE</b>	Digital Output State at 0% Output	1OF2OF (Output relays 1 and 2 are both de-energized) 1ON2OF (Output relay 1 is energized, output relay 2 is de-energized) 1OF2ON (Output relay 1 is de-energized, output relay 2 is energized) 1ON2ON (Output relays 1 and 2 are both energized)	1OF2ON
<b>RLY TYPE</b>	Relay Cycle Time Increments	MECHAN (Cycle time in one second increments) SOL ST (Cycle time in 1/3 second increments: 1 = .33 seconds, 120 = 40 seconds)	MECHAN

### 3.9 Input 1 Parameters Set Up Group

Table 3-8 Input 1 Group Function Prompts

Function Prompt Lower Display	Function Name	Selections or Range of Setting Upper Display	Factory Setting	
<b>IN1 TYPE</b>	Input 1 Actuation Type <i>For Input Range Minimum and Maximum see Appendix E</i>	DISABL	W TC H	0-10mV
		B TC	W TC L	
		E TC H	100 PT	
		E TC L	100 LO	
		J TC H	200 PT	
		J TC L	500 PT	
		K TC H	RAD RH	
		K TC L	RAD RI	
		NNM H	0-20mA	
		NNM L	4-20mA	
		NM90 H	0-10mV	
		NM90 L	0-50mV	
		NIC TC	0-5 V	
		R TC	1-5 V	
		S TC	0-10 V	
		<b>XMITTER1</b>	Transmitter Characterization	
T TC L	OXYGEN			
B TC	S TC			
E TC H	T TC H			
E TC L	T TC L			
J TC H	W TC H			
J TC L	W TC L			
K TC H	100 PT			
K TC L	100 LO			
NNM H	200 PT			
NNM L	500 PT			
NM90 H	RAD RH			
NM90 L	RAD RI			
NIC TC	LINEAR			
R TC	SQROOT ANALYT			
<b>ANALYTIC</b>	Analytic Selections XMITTER1 must be set to ANALYT for this prompt to appear			NONE
		PH		
		ORP Mv	(Millivolts)	
		CONDms	(Milli Siemens)	
		CONDus	(Micro Siemens)	
		RSTVM^	(Megaohms)	
		TDS PPm	(Parts per Million)	
		TDS PPb	(Parts per Billion)	
		CONCPt	(Parts per Thousand)	
		DO PPm	(Parts per Million)	
		DO PPb	(Parts per Billion)	

Function Prompt Lower Display	Function Name	Selections or Range of Setting Upper Display	Factory Setting
IN1 HI	Input 1 High Range Value (Linear Inputs only)	–999. to 9999. floating (in engineering units)	1000
IN1 LO	Input 1 Low Range Value (Linear Inputs only)	–999. to 9999. floating (in engineering units)	0
RATIO 1	Input 1 Ratio	–20.00 to 20.00 (floats to 3 decimal places)	1.000
BIAS IN1	Input 1 Bias	–999. to 9999. (in engineering units)	0
FILTER 1	Input 1 Filter	0 to 120 seconds	0
BURNOUT1	Burnout Protection	NONE DOWN UP NO_FS	NONE
EMISSIV1	Emissivity	0.01 to 1.00	0.00

### 3.10 Input 2 Parameters Set Up Group

Table 3-9 Input 2 Group Function Prompts

Function Prompt Lower Display	Function Name	Selections or Range of Setting Upper Display	Factory Setting
IN2 TYPE	Input 2 Actuation Type  <i>For Input Range Minimum and Maximum see Appendix E</i>	DISABL NM90 L 500 PT B TC NIC TC RAD RH E TC H R TC RAD RI E TC L S TC 0-20mA J TC H T TC H 4-20mA J TC L T TC L 0-10mV K TC H W TC H 0-50mV K TC L W TC L 0-5 V NNM H 100 PT 1-5 V NNM L 100 LO 0-10 V NM90 H 200 PT SLIDEW	0-10mV

## Configuration

Function Prompt Lower Display	Function Name	Selections or Range of Setting Upper Display		Factory Setting
<b>XMITTER2</b>	Transmitter Characterization	B TC E TC H E TC L J TC H J TC L K TC H K TC L NNM H NNM L NM90 H NM90 L NIC TC R TC	S TC T TC H T TC L W TC H W TC L 100 PT 100 LO 200 PT 500 PT RAD RH RAD RI LINEAR SQROOT ANALYT	LINEAR
<b>ANALYTIC</b>	Analytic Selections XMITTER2 must be set to ANALYT for this prompt to appear	NONE PH ORP Mv (Millivolts) CONDms (Milli Siemens) CONDus (Micro Siemens) RSTVM^ (Megaohms) TDS PPM (Parts per Million) TDS PPb (Parts per Billion) CONCPt (Parts per Thousand) DO PPM (Parts per Million) DO PPb (Parts per Billion)		NONE
<b>IN2 HI</b>	Input 2 High Range Value (Linear Inputs only)	-999. to 9999. floating (in engineering units)		1000
<b>IN2 LO</b>	Input 2 Low Range Value (Linear Inputs only)	-999. to 9999. floating (in engineering units)		0
<b>RATIO 2</b>	Input 2 Ratio	-20.00 to 20.00		1.000
<b>BIAS IN2</b>	Input 2 Bias	-999. to 9999. (in engineering units)		0
<b>FILTER 2</b>	Input 2 Filter	0 to 120 seconds		1
<b>BURNOUT2</b>	Burnout Protection	NONE DOWN UP NO_FS		NONE
<b>EMISSIV2</b>	Emissivity	0.01 to 1.00		0.00

### 3.11 Input 3 Parameters Set Up Group

**Table 3-10 Input 3 Group Function Prompts**

Function Prompt Lower Display	Function Name	Selections or Range of Setting Upper Display	Factory Setting
<b>IN3 TYPE</b>	Input 3 Actuation Type	DISABL 0-20mA 4-20mA 0-5 V 1-5 V	DISABL
<b>XMITTER3</b>	Transmitter Characterization	B TC      S TC E TC H    T TC H E TC L    T TC L J TC H    W TC H J TC L    W TC L K TC H    100 PT K TC L    100 LO NNM H    200 PT NNM L    500 PT NM90 H   RAD RH NM90 L   RAD RI NIC TC    LINEAR R TC      SQROOT	LINEAR
<b>IN3 HI</b>	Input 3 High Range Value (Linear Inputs only)	–999. to 9999. floating (in engineering units)	1000
<b>IN3 LO</b>	Input 3 Low Range Value (Linear Inputs only)	–999. to 9999. floating (in engineering units)	0
<b>RATIO 3</b>	Input 3 Ratio	–20.00 to 20.00	1.000
<b>BIAS IN3</b>	Input 3 Bias	–999. to 9999. (in engineering units)	0
<b>FILTER 3</b>	Input 3 Filter	0 to 120 seconds	1

### 3.12 Loop 1 Control Parameters Set Up Group

**Table 3-11 Control Group Function Prompts**

Function Prompt Lower Display	Function Name	Selections or Range of Setting Upper Display			Factory Setting
<b>PV SOURC</b>	Process Variable Source	INP 1 INP 2	IN AL1 IN AL2	INP 3	INP 1
<b>PID SETS</b>	Tuning Parameter Sets	1 ONLY 2KEYBD 2PV SW 2SP SW GAIN S (Gain scheduling automatically disables Accutune for this loop)			1 ONLY
<b>SW VALUE</b>	Automatic Switchover Value	Value in engineering units within PV or SP range limits			0.00
<b>LSP'S</b>	Local Setpoint Source	1 ONLY TWO THREE (Selection automatically disables RSP SRC)			1 ONLY
<b>RSP SRC</b>	Remote Setpoint Source	NONE INP 2	IN AL1 IN AL2	INP 3	NONE
<b>AUTOBIAS</b>	Automatic Bias	ENABLE DISABL			DISABL
<b>SP TRACK</b>	Local Setpoint Tracking	NONE PV RSP			NONE
<b>PWR MODE</b>	Power Up Mode Recall	MANUAL A LSP A RSP AM SP AM LSP			MANUAL
<b>PWR OUT</b>	TPSC Output Start-up Mode	LAST F'SAFE			LAST
<b>SP HiLIM</b>	Setpoint High Limit	0 to 100% of span input in engineering units			1000
<b>SP LoLIM</b>	Setpoint Low Limit	0 to 100% of span input in engineering units			0
<b>ACTION</b>	Control Output Direction	DIRECT REVRSE			REVRSE



Function Prompt Lower Display	Function Name	Selections or Range of Setting Upper Display	Factory Setting
<b>OUT RATE</b>	Output Change Rate	ENABLE DISABL <b>Does not apply to 3 Position Step Control algorithm.</b>	DISABL
<b>PCT/M UP</b>	Output Rate Up Value	0 to 9999 % per minute	0
<b>PCT/M DN</b>	Output Rate Down Value	0 to 9999 % per minute	0
<b>OUTHILIM</b>	High Output Limit	-5.0 to 105 % of output	100
<b>OUTLoLIM</b>	Low Output Limit	-5.0 to 105 % of output	0.0
<b>I Hi LIM</b>	High Reset Limit	Within the range of the output limits	100.0
<b>I Lo LIM</b>	Low Reset Limit	Within the range of the output limits	0.0
<b>DROPOFF</b>	Controller Dropoff Value	-5 to 105 % of output	0
<b>DEADBAND</b>	Output Relay Deadband	<i>Time Duplex:</i> -5.0 to 25.0 %  <i>On/Off Duplex:</i> 0.0 to 25.0 %  <i>Position Prop. and 3P Step:</i> 0.5 to 5.0 %	1.0
<b>OUT HYST</b>	Output Relay Hysteresis	0.0 to 100.0 % of PV Span for On/Off control.	0.5
<b>FAILMODE</b>	Failsafe Mode	NO LAT LATCH	NO LAT
<b>FAILSAFE</b>	Failsafe Output Value for all outputs except 3P Step	Set within the range of the output limits. 0 to 100 %	0.0
	Failsafe Output Value for 3P Step	0 PCT (motor to closed position) 100PCT (motor to open position)	--
<b>SW FAIL</b>	PDMMR/Position Proportional motor position when slidewire fails.	0 PCT (motor to closed position) 100PCT (motor to open position)	
<b>MAN OUT</b>	Power-up Preset Output for Manual Output	Within the range of output limits	--
<b>AUTO OUT</b>	Power-up Preset Output for Automatic Output	Within the range of output limits	--
<b>PBoRGAIN</b>	Proportional Band or Gain Units	PB PCT GAIN	GAIN
<b>MINorRPM</b>	Reset Units	RPM MIN	MIN

### 3.13 Loop 2 Control Parameters Set Up Group

Table 3-12 Loop 2 Control Parameters Set Up Group

Function Prompt Lower Display	Function Name	Selections or Range of Setting Upper Display	Factory Setting
<b>PV 2 SRC</b>	Process Variable Source	INP 1 INP 2 IN AL1 IN AL2 INP 3	INP 2
<b>FORCE MA</b>	Force Manual	DISABL LINK12	DISABL
<b>PID SETS</b>	Tuning Parameter Sets	1 ONLY 2KEYBD 2PV SW 2SP SW GAIN S (Gain scheduling automatically disables Accutune for this loop)	1 ONLY
<b>SW VALUE</b>	Automatic Switchover Value	Value in engineering units within PV or SP range limits	0.00
<b>LSP'S</b>	Local Setpoint Source	1 ONLY TWO THREE (Selection automatically disables RSP SRC)	1 ONLY
<b>RSP SRC</b>	Remote Setpoint Source	NONE INP 2 IN AL1 IN AL2 INP 3	NONE
<b>AUTOBIAS</b>	Automatic Bias	ENABLE DISABL	DISABL
<b>SPTRACK</b>	Local Setpoint Tracking	NONE PV RSP	NONE
<b>SP HiLIM</b>	Setpoint High Limit	0 to 100 % of PV span input in engineering units	1000
<b>SP LoLIM</b>	Setpoint Low Limit	0 to 100 % of PV span input in engineering units	0

Function Prompt Lower Display	Function Name	Selections or Range of Setting Upper Display	Factory Setting
<b>ACTION</b>	Control Output Direction	DIRECT REVRSE	REVRSE
<b>OUT RATE</b>	Output Change Rate	ENABLE DISABL	DISABL
<b>PCT/M UP</b>	Output Rate Up Value	0 to 9999 % per minute	0
<b>PCT/M DN</b>	Output Rate Down Value	0 to 9999 % per minute	0
<b>OUTHILIM</b>	High Output Limit	–5 to 105 % of output	100
<b>OUTLoLIM</b>	Low Output Limit	–5 to 105 % of output	0
<b>I HiLIM</b>	High Reset Limit	Within the range of the output limits	100.0
<b>I LoLIM</b>	Low Reset Limit	Within the range of the output limits	0.0
<b>DROPOFF</b>	Controller Dropoff Value	–5 to 105 % of output	0
<b>DEADBAND</b>	Output Relay Deadband	–5.0 to 5.0 %	1.0
<b>FAILMODE</b>	Failsafe Mode	NO LAT LATCH	NO LAT
<b>FAILSAFE</b>	Failsafe Output Value	Set within the range of the output limits. 0 to 100 %	0

### 3.14 Options Set Up Group

**Table 3-13 Options Group Function Prompt**

Function Prompt Lower Display	Function Name	Selections or Range of Setting Upper Display	Factory Setting
<b>AUX OUT</b> or <b>CUR OUT2</b>	Auxiliary Output One Loop Selection OR Auxiliary Output Two Loops/Cascade Selection	DISABL OUTPUT PV 2 INP 1 SP DEV 2 INP 2 LSP 1 OUTPT2 INP 3 IN AL1 SP L2 CBOUT IN AL2 LSP1 2 PV DEV CBOUT2	DISABL
<b>4mA VAL</b>	Auxiliary Output Low Scaling Factor	Low scale value to represent 4 mA. Value in % for output, all others in engineering units.	0.0
<b>20mA VAL</b>	Auxiliary Output High Scaling Factor	High scale value to represent 20 mA. Value in % for output, all others in engineering units.	0
<b>DIG IN 1</b>	Digital Input 1 Selections NOTE: DIG IN 1 applies to Loop 1 when 2 LOOPS or CASCAD is configured.	NONE ToAout <u>HealthWatch</u> TO MAN TIMER RESETT1 TO LSP AM STA RESETT2 TO 2SP ToTUNE RESETT3 TO 3SP Spinit R ALL T TO DIR TRACK1 RESETC1 ToHOLD TRACK2 RESETC2 ToPID2 ToOUT2 RESETC3 PV 2IN TO RSP R ALL C PV 3IN D L1/2 R ALL TC RERUN RST FB TO RUN ToPURG ToBEGN LoFIRE STOP I MAN LT MAN FS REStot ToLOCK	NONE
<b>DIG1 COM</b>	Digital Input 1 Combinations	DISABL +DISAT +PID2 +ToSP1 +ToDIR +RUN +ToSP2	DISABL
<b>DIG IN 2</b>	Digital 2 Input Selections	Same as DIG IN 1 NOTE: DIG IN 2 applies to Loop 2 when 2 LOOPS or CASCAD is configured.	NONE
<b>DIG2 COM</b>	Digital Input 2 Combinations	Same as DIG1 COM	DISABL

### 3.15 Communications Set Up Group

If your controller does not have this option, the prompts will not appear.

**Table 3-14 Communications Group Function Prompts**

Function Prompt Lower Display	Function Name	Selections or Range of Setting Upper Display		Factory Setting
<b>ComSTATE</b>	Communications Option State	DISABL MB3K	MODBUS RS422	DISABL
<b>Com ADDR</b>	Communications Station Address	1 to 99		0
<b>ComADDR2</b>	Loop 2 Communications Station Address	1 to 99 When ComSTATE = MODBUS, ComADDR2 = Com ADDR		0
<b>SHED ENAB</b>	Shed Enable	DISABL ENABL		DISABL
<b>SHEDTIME</b>	Shed Time	0 to 255 sample periods (1 sample period = 0.666 seconds) 0 = No Shed		0
<b>PARITY</b>	Parity	NONE ODD EVEN  Fixed at NONE when ComSTATE = MODBUS		ODD
<b>BAUD</b>	Baud Rate	2400 4800 9600 19200		2400
<b>DUPLEX</b>	Duplex Operation	HALF FULL  <ul style="list-style-type: none"> <li>• When ComSTATE = MODBUS, this selection is fixed at HALF.</li> <li>• When the RS422/485/Auxiliary output option board is installed, this selection is fixed at HALF.</li> </ul>		HALF

## Configuration

Function Prompt Lower Display	Function Name	Selections or Range of Setting Upper Display	Factory Setting
<b>WS FLOAT</b>	Word Swap Order	FP B Floating Point big endian FP BB Floating Point big endian with byte-swapped FP L Floating Point little endian FP LB Floating Point little endian with Byte-swapped	
<b>TX DELAY</b>	Transmission Delay	1 to 500 milliseconds	1
<b>SHEDMODE</b>	Shed Controller Mode and Output Level	LAST TO MAN FSAFE ToAUTO	LAST
<b>SHEDSP</b>	Shed Setpoint Recall	TO LSP TO CSP	TO LSP
<b>UNITS</b>	Communication Units	PERCNT ENG	PERCNT
<b>CSP RATO</b>	Loop 1 Computer Setpoint Ratio	-20.0 to 20.0	1.0
<b>CSP BIAS</b>	Loop 1 Computer Setpoint Bias	-999. to 9999. (in engineering units)	0
<b>CSP2RATO</b>	Loop 2 or Cascade Computer Setpoint Ratio	-20.0 to 20.0	1.0
<b>CSP2BIAS</b>	Loop 2 or Cascade Computer Setpoint Bias	-999. to 9999. (in engineering units)	0
<b>LOOPBACK</b>	Local Loop Back	DISABL ENABLE	DISABL

### 3.16 Alarms Set Up Group

**Table 3-15 Alarms Group Function Prompts**

Function Prompt Lower Display	Function Name	Selections or Range of Setting Upper Display	Factory Setting
<b>A1S1 VAL</b>	Alarm 1, Setpoint 1 Value	Value in Engineering Units	90
<b>A1S2 VAL</b>	Alarm 1, Setpoint 2 Value	Value in Engineering Units	10
<b>A2S1 VAL</b>	Alarm 2, Setpoint 1 Value	Value in Engineering Units	95
<b>A2S2 VAL</b>	Alarm 2, Setpoint 2 Value	Value in Engineering Units	5
<b>A1S1TYPE</b>	Alarm 1, Setpoint 1 Type	NONE INP 1 INP 2 INP3 PV (Loop 1 Process Variable) DEV (Loop 1 Deviation) OUTPUT (Loop 1 Output) SHED (Both Loops) EV ON (Event On – SP Program) EV OFF (Event Off – SP Program) MANUAL (Loop 1) REM SP (Loop 1 Remote Setpoint) F SAFE (Loop 1 Failsafe) PVRATE (Loop 1 PV Rate of Change) PV 2 (Loop 2 Process Variable) DEV 2 (Loop 2 Deviation) OUT 2 (Loop 2 Output) MAN 2 (Loop 2 Manual ) RSP 2 (Loop 2 Remote Setpoint) F SAF2 (Loop 2 Failsafe) PVRAT2 (Loop 2 PV Rate of Change) BREAK BREAK2 TOTAL	NONE

*continued*

## Configuration

Function Prompt Lower Display	Function Name	Selections or Range of Setting Upper Display	Factory Setting
<b>A1S1TYPE</b>	Alarm 1, Setpoint 1 Type	<b>Health Watch</b>	
<b>continued</b>	continued	TIMER 1 TIMER 2 TIMER 3 COUNT 1 COUNT 2 COUNT 3	
<b>A1S2TYPE</b>	Alarm 1, Setpoint 2 Type	Same as A1S1TYPE	NONE
<b>A2S1TYPE</b>	Alarm 2, Setpoint 1 Type	Same as A1S1TYPE	NONE
<b>A2S2TYPE</b>	Alarm 2, Setpoint 2 Type	Same as A1S1TYPE	NONE
<b>A1S1 H L</b>	Alarm 1, Setpoint 1 State	LOW HIGH	HIGH
<b>A1S1 EV</b>	SP Programming Event Alarm State for Alarm 1, Setpoint 1	BEGIN END	--
<b>A1S2 H L</b>	Alarm 2, Setpoint 1 State	LOW HIGH	LOW
<b>A1S2 EV</b>	SP Programming Event Alarm State for Alarm 1, Setpoint 2	BEGIN END	--
<b>A2S1 H L</b>	Alarm 21, Setpoint 1 State	LOW HIGH	HIGH
<b>A2S1 EV</b>	SP Programming Event Alarm State for Alarm 2, Setpoint 1	BEGIN END	--
<b>A2S2 H L</b>	Alarm 2, Setpoint 2 State	LOW HIGH	LOW
<b>A2S2 EV</b>	SP Programming Event Alarm State for Alarm 2, Setpoint 2	BEGIN END	--
<b>AL HYST</b>	Alarm Hysteresis	0.0 to 100.0 % of output or span, as appropriate	0.1
<b>ALM OUT1*</b>	Latching Alarm for Output 1	NO LAT LATCH	NO LAT



Function Prompt Lower Display	Function Name	Selections or Range of Setting Upper Display	Factory Setting
<b>BLOCK</b>	Alarm Blocking	DISABL BLOCK1 BLOCK2 BLK 12	DISABL

\*For CE Conformity, Performance Criterion A, Select NO LAT

### 3.17 Display Parameters Set Up Group

**Table 3-16 Display Group Function Prompts**

Function Prompt Lower Display	Function Name	Selections or Range of Setting Upper Display	Factory Setting
<b>DECIMAL</b>	Control Loop 1 Decimal Place	XXXX XXX.X XX.XX X.XXX <b>ATTENTION</b> Auto-ranging will occur to whichever decimal place has been selected.	XXXX
<b>DECIMAL2</b>	Control Loop 2 Decimal Place	XXXX XXX.X XX.XX X.XXX	XXXX
<b>TEMPUNIT</b>	Control Loop 1 Temperature Units	DEG F DEG C NONE	NONE
<b>PWR FREQ</b>	Power Frequency	60 HZ or 50 HZ	60 HZ
<b>RATIO 2</b>	Ratio for Input 2—Set from the front of the controller	DISABL ENABLE	DISABL
<b>LANGUAGE</b>	Display Language	ENGLIS FRENCH GERMAN SPANIS ITALAN	ENGLIS

### 3.18 Calibration Group

The prompts used here are for field calibration purposes.

### 3.19 Maintenance Parameters Set Up Group

**Table 3-17 Maintenance Group Function Prompts**

Function Prompt Lower Display	Function Name	Selections or Range of Setting Upper Display	Factory Setting
<b>Time 1</b>	Timer 1	DISABL LASTR (Last Reset) AL1SP1 (Alarm 1 Setpoint 1) AL1SP2 (Alarm 1 Setpoint 2) AL2SP1 (Alarm 2 Setpoint 1) AL2SP2 (Alarm 2 Setpoint 2) MANUAL (Loop 1 Manual) GSOAK (Guaranteed Soak) SOOTING (Sooting State) DIGIN1 (Digital Input 1) DIGIN2 (Digital Input 2) MAN2 (Loop 2 Manual)	DISABL
<b>HRS.MIN1 or DAYS.HRS1</b>	Elapsed Time 1	Read Only	
<b>TIME 2</b>	Timer 2	Same as TIME 1	Disabl
<b>HRS.MIN2 or DAYS.HRS2</b>	Elapsed Time 2	Read Only	
<b>TIME 3</b>	Timer 3	Same as TIME 1	Disabl
<b>HRS.MIN3 or DAYS.HRS3</b>	Elapsed Time 3	Read Only	
<b>COUNTER 1</b>	Counter 1	DISABL MANUAL (Loop 1 Manual) AL1SP1 (Alarm 1 Setpoint 1) AL1SP2 (Alarm 1 Setpoint 2) AL2SP1 (Alarm 2 Setpoint 1) AL2SP2 (Alarm 2 Setpoint 2) DIGIN1 (Digital Input 1) DIGIN2 (Digital Input 2)	DISABL

Function Prompt Lower Display	Function Name	Selections or Range of Setting Upper Display	Factory Setting
<b>COUNTER 1</b>	Counter 1	OUT1*1K (Output 1 Relay x 1000)	
<b>continued</b>	continued	OUT2*1K (Output 2 Relay x 1000)	
		GSOAK (Guaranteed Soak)	
		PWRCYC (Power Cycle)	
		PV_RNG (Loop 1 PV Range)	
		FAILSF (Loop 1 Failsafe)	
		TUNE (Loop 1 Tune)	
		MAN2 (Loop 2 Manual)	
		PVRNG2 (Loop 2 PV Range)	
		FSF2 (Loop 2 Failsafe)	
		TUNE2 (Loop 2 Tune)	
<b>COUNTS 1</b>	Number of Counts 1	Read Only	
<b>COUNTER 2</b>	Counter 2	Same as Counter 1	DISABL
<b>COUNTS 2</b>	Number of Counts 2	Read Only	
<b>COUNTER 3</b>	Counter 3	Same as Counter 1	DISABL
<b>COUNTS 3</b>	Number of Counts 3	Read Only	
<b>PASSWORD</b>	Password	0-9999	0
<b>RESTYPE</b>	Reset Type	NONE (No value will be reset)	NONE
		TIMER1 (Timer 1 will be reset)	
		TIMER2 (Timer 2 will be reset)	
		TIMER3 (Timer 3 will be reset)	
		ALLTM (All timers will be reset)	
		COUNT1 (Counter 1 will be reset)	
		COUNT2 (Counter 2 will be reset)	
		COUNT3 (Counter 3 will be reset)	
		ALL CO (All counters reset)	
		ALL TC (All timers/counters reset)	

### 3.20 Status Group

The prompts used here are read only. They are used to determine the reason for a controller failure.



## 4. Operation

### 4.1 How to Power Up the Controller

When the power is applied, the controller will run three diagnostic tests. All the displays will light and then the controller will go into automatic mode after 20 seconds.

If one or more of these tests fail, the controller will go to the Fail-safe Manual Mode, and “FAILSAFE” will flash in the lower display.

If the output type is Position Proportional, and AUTO-CAL has never been done, a prompt “CAL MTR” will appear suggesting that the controller be calibrated.

*(See Appendix D – Position Proportional Calibration.)*

#### Key Error

When a key is pressed and the prompt “KEY ERROR” appears in the lower display, it will be for one of the following reasons:

- parameter is not available,
- not in Set Up mode, press **SET UP** key first,
- key malfunction, do keyboard test.

### 4.2 Monitoring Your Controller

#### Operator Interface

The indicators and displays on the operator interface let you see what is happening to your process and how the controller is responding. Figure 1-1 is a view of the operator interface. A description of the displays and indicators is included.

#### Decimal Point Position

None, one or two decimal places are indicated on configuration. When a single decimal position has been configured and values greater than 1000 are displayed, the right-most character is blank, but the decimal point will be lit.

#### Viewing the Operating Parameters

Press the LOWER DISPLAY key to scroll through the operating parameters listed in Table 4-1. The lower display will show only those parameters and their values that apply to your specific model and the way in which it was configured.

Table 4-1 Lower Display Key Parameter Prompts

Indication	Description
OUT	OUTPUT #1—Output value is percent; for Three Position Step control, this is an estimated motor position when no slidewire exists.
OT2	OUTPUT #2—Appears only if 2-loop or Cascade control is configured.
SP	LOCAL SETPOINT #1—Also current setpoint when using SP Ramp.
2SP	LOCAL SETPOINT #2
3SP	LOCAL SETPOINT #3
RSP	REMOTE SETPOINT
1IN	INPUT 1—Used only with combinational input algorithms.
2IN	INPUT 2
3IN	INPUT 3
POS	SLIDEWIRE POSITION—Used only with TPSC.
CSP	COMPUTER SETPOINT—When SP is in override.
DEV	DEVIATION—Maximum negative display is -999.9.
PIDSETX	TUNING PARAMETER SET 1—Selected set for single loop or <b>primary</b> loop configuration where X is either 1 or 2.
2PIDSETX	TUNING PARAMETER SET 2—Selected set for <b>secondary</b> loop configuration where X is either 1 or 2.
ET XX.XX	ELAPSED TIME—Time that has elapsed on timer in Hours.Minutes.
TR XX.XX	TIME REMAINING—Time that remains on timer in Hours.Minutes
RAMPXXXM	SETPOINT RAMP TIME—Time remaining in the setpoint ramp in minutes.
O SK XXXX	Soak # and TIME REMAINING IN SOAK
1PV	PROCESS VARIABLE 1—For Cascade or 2-loop applications.
2PV	PROCESS VARIABLE 2—For Cascade or 2-loop applications.
AUX	AUXILIARY OUTPUT—Displayed only when Loop 2 is not used, or when Loop 2 is Time Simplex and Loop 1 is not Current Duplex.
OC1	CHARACTERIZED OUTPUT 1—Displayed if Loop 1 output is characterized.
OC2	CHARACTERIZED OUTPUT 2—Displayed if Loop 2 output is characterized.
SPn	SP RATE SETPOINT—Current setpoint for setpoint rate applications
Σ (Sigma)	CURRENT TOTALIZATION VALUE—Displays the total flow volume being measured.
BIA	BIAS—Displays the manual reset value for algorithm PD+MR.
TUNE OFF	LIMIT CYCLE TUNING NOT RUNNING—Appears when Accutune is disabled.
TUNE RUN	LIMIT CYCLE TUNING RUNNING—Appears when Accutune is enabled.
ToBEGIN	RESET SP PROGRAM TO BEGINNING OF FIRST SEGMENT
OTI	OUTPUT OVERRIDE (2 PID LOOPS ONLY)—Appears when internal Loop 1 Output value is displayed. This represents the internal output 1 value before override.

## Diagnostic Error Messages

The UDC3300 performs background tests to verify data and memory integrity. If there is a malfunction, an error message will be displayed. In the case of more than one simultaneous malfunction, only the one with the highest priority will appear on the lower display. A list of error messages is contained in Table 4-2. If any of these error messages occur, call your service support representative.

**Table 4-2 Error Messages**

Prompt	Description
<b>EE FAIL</b>	Unable to write to nonvolatile memory.
<b>INP1FAIL</b>	Two consecutive failures of input 1 integration.
<b>INP2FAIL</b>	Two consecutive failures of input 2 integration.
<b>INP3FAIL</b>	Two consecutive failures of input 3 integration.
<b>SW FAIL</b>	Slidewire input failure. Position proportional control automatically switched to TPSC.
<b>CONF ERR</b>	Configuration Errors for Loop 1—Low limit greater than high limit for PV, SP, Reset, or Output.
<b>CONF ER2</b>	Configuration Errors for Loop 2—Low limit greater than high limit for PV, SP, Reset, or Output, or Loop 2 output has not been selected.
<b>SOOTING</b>	Input Combination Errors—Percent Carbon falls outside of “sooting boundary.”
<b>IN1 RNG</b>	Input 1 Out-of-Range
<b>IN2 RNG</b>	Input 2 Out-of-Range
<b>IN3 RNG</b>	Input 3 Out-of-Range
<b>PV RNG</b>	PV Out-of-Range $PV = (PV \text{ source} \times PV \text{ source ratio}) + PV \text{ source bias}$
<b>FAILSAFE</b>	Failsafe Loop 1—Check inputs or configuration.
<b>FAILSF2</b>	Failsafe Loop 2—Check inputs or configuration.
<b>RV LIMIT</b>	Remote Variable Out-of-Range $RV = (RV \text{ source} \times RV \text{ source ratio}) + RV \text{ source bias}$
<b>RH LO</b>	RH Excessive Temperature Depression—Calculated %RH is less than 0%.
<b>SEG ERR</b>	Segment Error—SP Program starting segment number is less than ending segment number.
<b>CAL MTR</b>	Not calibrated. Perform Position Proportional calibration.

### 4.3 Start-up Procedure

Table 4-3 Procedure for Starting Up the Controller

Step	Operation	Press	Action
1	Select the loop	<b>FUNCTION LOOP 1/2</b>	to toggle between Loop 1 and Loop 2, if configured.
2	Select manual mode	<b>MANUAL AUTO</b>	until "MAN" indicator is ON. The controller is in manual mode.
3	Adjust the output	<b>▲ or ▼</b>	to adjust the output value and ensure that the final control element is functioning correctly. Upper Display shows the PV value Lower Display shows OUT and the output value in %.
4	Enter the local setpoint	<b>LOWER DISPLAY</b> <b>▲ or ▼</b>	Upper Display shows the PV Value Lower Display shows SP and the local setpoint value  to adjust the local setpoint to the value at which you want the process variable maintained.  The local setpoint cannot be changed if the Setpoint Ramp function is running. "R" appears in the upper display.
5	Select automatic mode	<b>MANUAL AUTO</b>	until "A" indicator is ON. The controller is in Automatic mode.  The controller will automatically adjust the output to maintain the process variable at setpoint, if the controller is properly tuned.
6	Tune the controller	<b>SET UP</b>	Tuning will be required on the first startup. First enable "TUNE" selection in the Accutune Group.  Refer to Tuning Set Up group to ensure that the proper selections for PROP BD or GAIN, RATE MIN, and RSET MIN, or RSET RPM have been entered.  Use Accutune to tune the controller as follows: <ol style="list-style-type: none"> <li>1. Adjust setpoint to the desired value.</li> <li>2. Switch to Automatic mode by pressing the MANUAL/AUTO key.</li> <li>3. Initiate Tuning by: <ul style="list-style-type: none"> <li>• Pressing the up arrow key when the lower display prompt shows TUNE-OFF, or</li> <li>• Pressing the LOWER DISPLAY and Up arrow keys simultaneously, or...</li> <li>• Using the Digital Input, if configured.</li> </ul> </li> </ol> If it is necessary to stop or abort the tuning process, press the MANUAL/AUTO key and the controller will return to manual mode.



## 4.4 Operating Modes

The controller can operate in any of three basic modes:

- Manual – One or Two Loops
- Automatic with Local Setpoint – One or Two Loops
- Automatic with Remote Setpoint – One or Two Loops
- Manual Cascade
- Automatic Cascade

## 4.5 Setpoints

You can configure the following setpoints for the UDC3300 controller in the control group.

- A single local setpoint (SP)
- Two local setpoints (SP, 2SP)
- One local setpoint and one remote setpoint (SP, RSP)
- Three local setpoints (SP, 2SP, 3SP)
- Two local setpoints and one remote setpoint (SP, 2SP, RSP)

### Changing Local Setpoint 1, 2 or 3

To scroll through the setpoint type menu, press and hold in the SETPOINT SELECT key. Release when the desired active setpoint selection is displayed.

#### ATTENTION

“KEY ERROR” will appear in the lower display if:

- You choose either local setpoint 2 or 3 or remote setpoint and your choice has not been configured as the setpoint source.
- You attempt to change the setpoint while a Setpoint Ramp is enabled.
- Setpoint Ramp rate will apply to Local SP changes, if enabled.

After changing a local setpoint value, if no other key is pressed, a minimum of 30 seconds time will elapse before the new value is stored in nonvolatile memory. If power is removed before this time, the new setpoint value is lost and the previous setpoint value is used at power up. If after changing the LSP value another key is pressed, then the value is stored immediately.

## Setpoint Selection Indication

Table 4-4 Setpoint Selection Indication

	Using Local Setpoint	Using Remote Setpoint	Using 2nd Local Setpoint	Using 3rd Local Setpoint
	SP	RSP	2SP	3SP
Upper Display	PV and the PV value	PV and the PV value	PV and the PV value	PV and the PV value
Lower Display	SP and the Local Setpoint Value	RSP and Remote Setpoint Value	2SP and the 2nd Local Setpoint Value	3SP and the 3rd Local Setpoint Value
Annunciator	None	“■” lights	“■” lights	“3” lights

## 4.6 Using Two Sets of Tuning Constants

## Select Two Sets or Gain Scheduling

Table 4-5 Procedure for Selecting Two Sets of Tuning Constants

Step	Operation	Press	Action
1	Select Control Set Up group	<b>SET UP</b>	until you see SET UP in Upper Display and CONTROL or CONTROL2 in Lower Display
2	Select PID SETS function	<b>FUNCTION LOOP 1/2</b>	until you see the function desired in the Upper Display and PID SETS in the Lower Display
		▲ or ▼	to select the type of PID SET.

## Set Switchover Value

If you select 2 PVSW or 2 SPSW, you must set a value at which the sets will switch over. The procedure in Table 4-6 shows you how to set this value. ***This procedure assumes that you are still in the Control Set Up group from Table 4-5.***

Table 4-6 Procedure for Setting Switchover Values

Step	Operation	Press	Action
1	Select Switchover value function	<b>FUNCTION LOOP 1/2</b>	until you see the switch over value in the Upper Display and SW VALUE in the Lower Display.
		▲ or ▼	to select the switch-over value in the upper display.

## Set Tuning Constant Values for Each Set

There are specific tuning constants that must be set for each set. The procedure below shows you how to access these constants and change their value.

**Table 4-7 Procedure for Setting Tuning Constant Values**

Step	Operation	Press	Action
1	Select Tuning Set Up Group	<b>SET UP</b>	until you see TUNING in the Lower Display
2	Select the tuning constants	<b>FUNCTION LOOP 1/2</b>	to successively display the available constants in the Lower Display. The value is displayed in the Upper Display
		<b>▲ or ▼</b>	To change the value of any of the above listed prompts in the lower display.

## Switch Between Two Sets via the Keyboard (Without Automatic Switchover)

This procedure is operational only if 2 PID SETS was configured at the Control Set Up group.

**Table 4-8 Procedure for Switching PID SETS from the Keyboard**

Step	Operation	Press	Action
1	Access the PID set display	<b>LOWER DISPLAY</b>	until you see the PV value displayed in the Upper Display and the PIDSETx in the Lower Display.
		<b>▲ or ▼</b>	to change PID SET 1 to PID SET 2 or vice versa.  You can use Accutune on each set.

## 4.7 Alarm Setpoints

### Procedure for Displaying the Alarm Setpoints

**Table 4-9 Procedure for Displaying or Changing the Alarm Setpoints**

Step	Operation	Press	Action
1	Access the Alarm Set Up group	<b>SET UP</b>	until you see ALARMS in the Lower Display.
2	Access the Alarm Setpoint Values	<b>FUNCTION LOOP 1/2</b>  ▲ or ▼	to successively display the alarm setpoints and their values.  to change any alarm setpoint value you select in the upper display.
3	Return to normal operation	<b>LOWER DISPLAY</b>	

## 4.8 Two Loops of Control

The UDC3300 can operate using two independent loops of control or internal Cascade control.

### Two Independent Loops

The following rules apply for two independent loops:

- Current output on Loop 2 requires auxiliary output.
- Loop 2 Current Duplex output is limited to 2nd Current output signal only.
- Loop 2 relay output is always dedicated to relay output 2.
- No Time Duplex outputs on Loop 2.
- No ON/OFF or 3 Position Step algorithms on Loop 2.
- No Position Proportional output is available on 2-loop controllers.

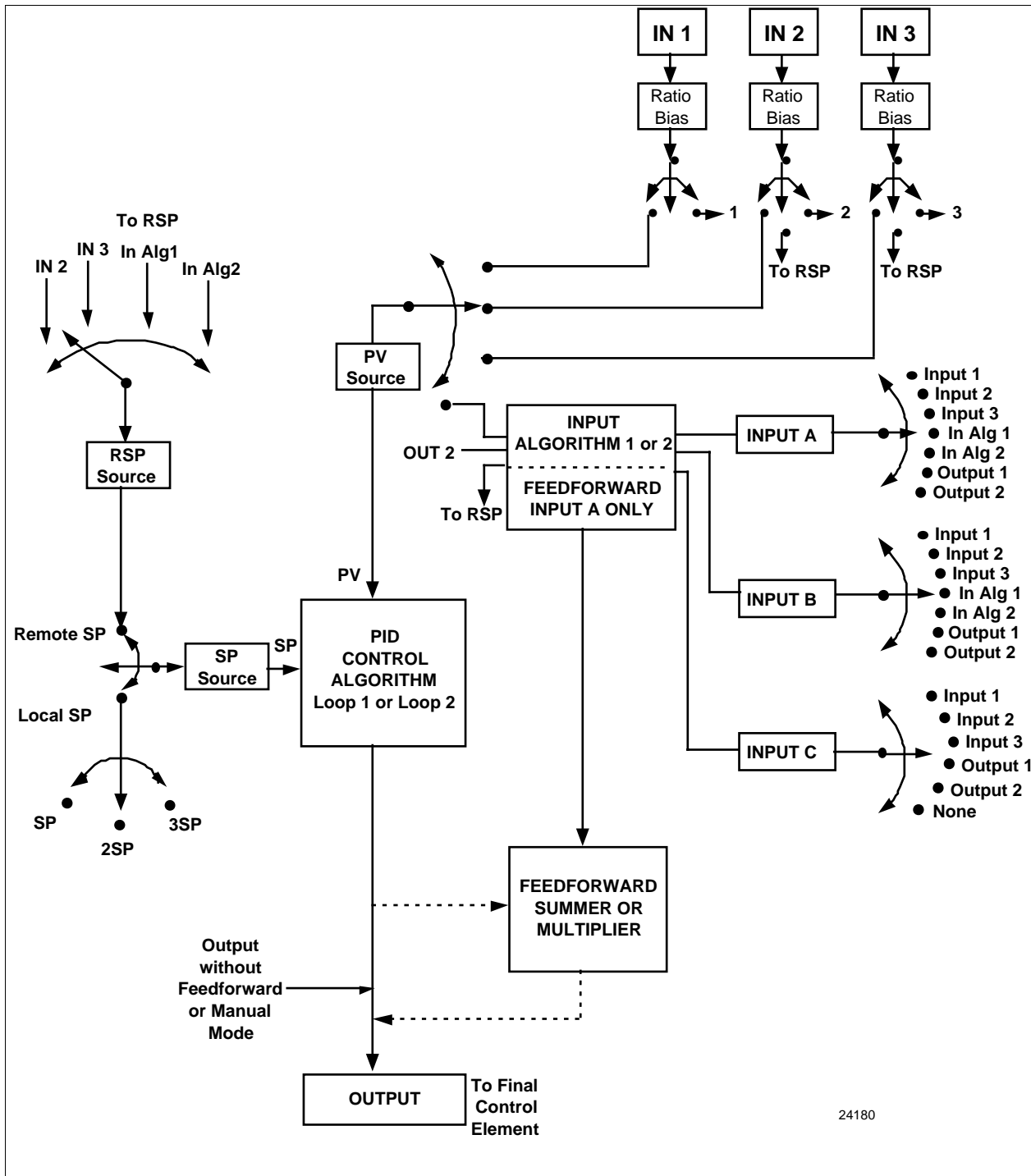
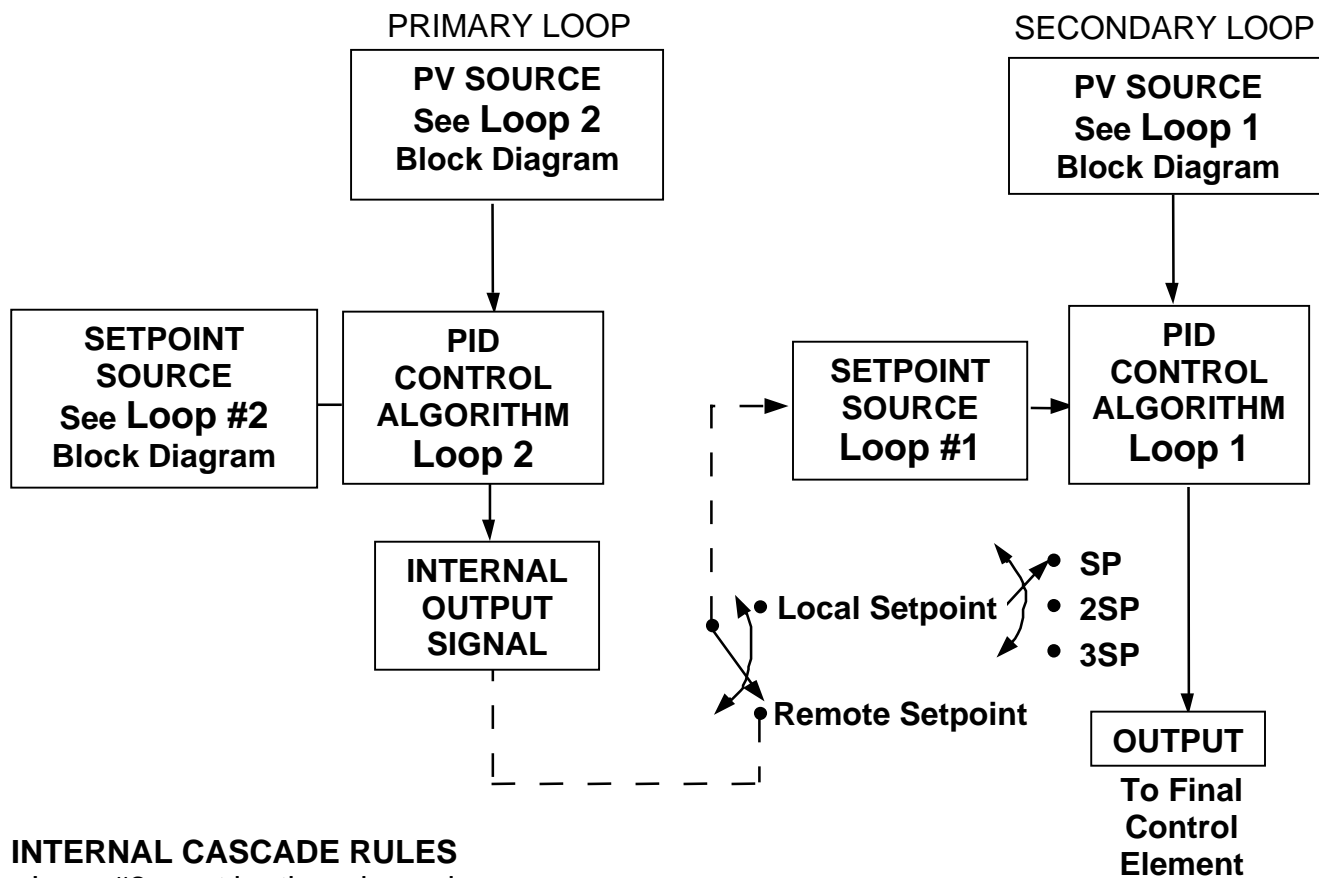

Figure 4-1 Functional Overview Block Diagram of a Single Loop (Loop #1) or Dual Loop Controller (Loop #1 and Loop #2)

### Internal Cascade Control

The following rules apply for internal Cascade control:

- Loop 2 must be the primary loop.
- Loop 1 must be the secondary (internal or slave) loop because all output forms exist on Loop 1.
- Loop 1 remote setpoint is fixed as Loop 2 output.
- No Position Proportional output is available on cascade controllers.



### INTERNAL CASCADE RULES

- Loop #2 must be the primary loop.
- Loop #1 must be the secondary (internal or slave) loop because all output forms exist on Loop 1.
- Loop #1 Remote setpoint is fixed as Loop #2 output.

24182

**Figure 4-2 Functional Overview Block Diagram of Internal Cascade of a 2-loop Controller**

**Table 4-10 Control Loops Selections**

Loop		Input 1	Input 2	Input Algorithm
<b>LOOP 1</b>	Process Variable*	Via Configuration or Digital Inputs	Via Configuration or Digital Inputs	Yes
	Remote Setpoint	No	Via configuration or Digital Inputs	Yes
	Feedforward	No	Yes	Yes
<b>LOOP 2</b>	Process Variable*	Via Configuration or Digital Inputs	Via Configuration or Digital Inputs	Yes
	Remote Setpoint	No	Via Configuration or Digital Inputs	Yes
	Feedforward	No	Yes	Yes

**Override Rules**

The UDC3300 allows you to select high or low output override. Refer to *Section 3 - Configuration* to select High or Low.

The following rules apply for high/low override:

- Only one physical output is required when override is enabled. It is the output from Loop 1 because Loop 2's internal output is routed through the selector.
- Loop 2 output can also be available at all times if desired.
- In Manual mode, the Output may be overridden.
- Does not apply for Three Position Step Control.
- OTI on bottom display shows value of the internal Loop 1 output before any override.

**ATTENTION**

The output of the unselected loop tracks the selected loop to within 5% when in Auto mode to eliminate windup. This tracking is done in the direction opposite to the Override Select configuration; i.e., for High Select, the unselected output tracks within 5% of lower and vice versa.

## Two Loop Restrictions

**Table 4-11 Two Loop Functionality and Restrictions  
(Models DC330E-EE-2XX or DC330E-EE-5XX)**

<b>Controller with One Current Output (Auxiliary Output) and Three Relay Outputs</b>					
<b>Output Type</b>	<b>Current</b>	<b>Auxiliary</b>	<b>Relay #1</b>	<b>Relay #2</b>	<b>Relay #3</b>
<b>Loop 1 is TIME SIMPLEX, Loop 2 is:</b>					
Time Simplex	N/A	Not used	Loop 1 Out	Loop 2 Out	Alarm 1
Current or Current Duplex (100%)	N/A	Loop 2 Out	Loop 1 Out	Alarm 2	Alarm 1
Current/Time or Time/Current	N/A	Loop 2: Out 1 or 2	Loop 1 Out	Loop 2: Out 1 or 2	Alarm 1
<b>Loop 1 is TIME DUPLEX/TPSC, Loop 2 is:</b>					
Time Simplex (N/A)	—	—	—	—	—
Current or Current Duplex (100%)	N/A	Loop 2 Out	Loop 1, Output 1	Loop 1, Output 2	Alarm 1
Current/Time or Time/Current (N/A)	—	—	—	—	—
<b>Loop 1 is CURRENT OUTPUT or CURRENT DUPLEX – 100%, Loop 2 is:</b>					
Time Simplex	N/A	Loop 1 Out	Loop 2 Out	Alarm 2	Alarm 1
Current or Current Duplex (N/A)	—	—	—	—	—
Current/Time or Time/Current (N/A)	—	—	—	—	—
<b>Loop 1 is TIME/CURRENT or CURRENT/TIME, Loop 2 is:</b>					
Time Simplex	N/A	Loop 1: Out 1 or 2	Loop 1: Out 1 or 2	Loop 2 Out	Alarm 1
Current or Current Duplex (N/A)	—	—	—	—	—
Current/Time or Time/Current(N/A)	—	—	—	—	—



**Table 4-12 Two Loop Functionality and Restrictions  
(Models DC330E-KE-2XX or DC330E-KE-5XX)**

<b>Controller with Two Current Outputs (including Auxiliary Output) and Three Relay Outputs</b>					
<b>Output Type</b>	<b>Current</b>	<b>Auxiliary</b>	<b>Relay #1</b>	<b>Relay #2</b>	<b>Relay #3</b>
<b>Loop 1 is TIME SIMPLEX, Loop 2 is:</b> Time Simplex Current or Current Duplex (100%) Current/Time or Time/Current	Not used Not used Not used	Not used Loop 2 Out Loop 2: Out 1 or 2	N/A N/A N/A	Loop 1 Out Loop 1 Out Loop 1 Out	Loop 2 Out Alarm 1 Loop 2: Out 1 or 2
<b>Loop 1 is TIME DUPLEX/TPSC, Loop 2 is:</b> Time Simplex (N/A) Current or Current Duplex (100%) Current/Time or Time/Current (N/A)	— Not used —	— Loop 2 Out —	— N/A —	— Loop 1, Output 1 —	— Loop 1, Output 2 —
<b>Loop 1 is CURRENT OUTPUT or CURRENT DUPLEX – 100%, Loop 2 is:</b> Time Simplex Current or Current Duplex (100%) Current/Time or Time/Current (N/A)	Loop 1 Out Loop 1 Out Loop 1 Out	Not used Loop 2 Out Loop 2: Out 1 or 2	N/A N/A N/A	Loop 2 Out Alarm 2 Loop 2: Out 1 or 2	Alarm 1 Alarm 1 Alarm 1
<b>Loop 1 is CURRENT DUPLEX – 50%, Loop 2 is:</b> Time Simplex Current (N/A) Current/Time or Time/Current (N/A)	Loop 1, Output 1 — —	Loop 1, Output 2 — —	N/A — —	Loop 2 Out — —	Alarm 1 — —
<b>Loop 1 is TIME/CURRENT or CURRENT/TIME, Loop 2 is:</b> Time Simplex Current or Current Duplex (100%) Current/Time or Time/Current	Loop 1: Out 1 or 2 Loop 1: Out 1 or 2 Loop 1: Out 1 or 2	Not used Loop 2 Out Loop 2: Out 1 or 2	N/A N/A N/A	Loop 1: Out 1 or 2 Loop 1: Out 1 or 2 Loop 1: Out 1 or 2	Loop 2 Out Alarm 1 Loop 2: Out 1 or 2

### Select 2-loop Algorithm

**Table 4-13 Procedure for Selecting 2-loop Algorithm**

Step	Operation	Press	Action
1	Select Algorithm Set Up Group	<b>SET UP</b>	until you see ALGORITHM in the Lower Display
2	Select the PID Loops	<b>FUNCTION LOOP 1/2</b> <b>▲ or ▼</b>	to successively display the PID loop constants To select two Loops or Cascade control.

---

### Select the Output Algorithm for Each Loop

**Table 4-14 Procedure for Selecting Output Algorithm**

Step	Operation	Press	Action
1	Select Output Algorithm Set Up Group	<b>SET UP</b>	until you see OUT ALG in the lower display.
2	Select Loop 1 Algorithms	<b>FUNCTION LOOP 1/2</b> <b>▲ or ▼</b>	to successively display the Loop 1 algorithms. to select Loop 1 algorithm from the selections that are available.
3	Select Loop 2 Algorithms	<b>FUNCTION LOOP 1/2</b> <b>▲ or ▼</b>	until you see OUT ALG2 in the lower display. to select Loop 2 algorithm from the selections that are available.

---

### Select Control Parameters for Each Loop

**Table 4-15 Procedure for Selecting Control Parameters**

Step	Operation	Press	Action
1	Select Control Set Up Group	<b>SET UP</b>	until you see: CONTROL for Loop 1 or CONTROL2 for Loop 2 in the Lower Display.  Refer to <i>Table 4-11, Table 4-12, and Table 4-13</i> for rules and restrictions <b>and</b> to <i>Section 3 – Configuration</i> to select the individual parameters.

---

## Selecting Tuning Parameters for Each Group

**Table 4-16 Procedure for Selecting Tuning Parameters**

Step	Operation	Press	Action
1	Select Tuning Set Up Group	<b>SET UP</b>	<p>until you see: TUNING FOR Loop 1 or TUNING2 for Loop 2.</p> <p>PID sets 1 and 2 (TUNING) are for Loop 1 and single loop applications.</p> <p>PID sets 3 and 4 (TUNING 2) are for Loop 2 in two-loop and cascade control applications.</p>
2	Select Tuning constants	<b>FUNCTION LOOP 1/2</b>	<p>to successively display the constants for the Primary Loop OR Loop 2.</p> <p>Refer to <i>Section 3 - Configuration</i> for detailed information.</p> <p>You can Autotune both sets on either loop. Refer to <i>Section 4.15</i>.</p> <p>Use the FUNCTION key to switch between loops for display and monitoring.</p>
▲ or ▼			to change the values.

## 4.9 Monitoring Two Loops of Control

### Loop Display

Display of Loop 1 or Loop 2 (if configured) is selected by toggling the FUNCTION / LOOP 1/2 key.

The indicator which identifies which loop is being monitored is displayed in the left-most character in the Upper Display

**Table 4-17 Digital Display Indication—Two Loops**

Loop Indicator	Loop Indication	Definition
<b>None</b> (If Two Loops are configured)	Loop 1 is being displayed.	<ul style="list-style-type: none"> <li>Upper display shows the Process Variable (PV) for Loop 1</li> <li>Lower display shows the Loop 1 parameters and the PV and Output for Loop 2</li> <li>Controller setpoint annunciators show the setpoint currently being used for Loop 1</li> </ul>
<b>I</b> (If cascade is configured)		
<b>L"</b>	Loop 2 is being displayed	<ul style="list-style-type: none"> <li>Upper display shows the Process Variable (PV) for Loop 2</li> <li>Lower display shows the Loop 2 parameters and the PV and Output for Loop 1</li> <li>Controller setpoint annunciators show the setpoint currently being used for Loop 2</li> </ul>

### Viewing Each Loop's Process Variable

Regardless of which loop is being displayed, 1 or 2, the process variable of the non-displayed loop can be shown in the lower display by repeated presses of the LOWER DISPLAY key until **1PVXXXX** or **2PVXXXX** is displayed.

### Internal Cascade Indication

When internal Cascade has been configured, an "I" will appear on the left side of the upper display as long as Loop 1 is operating in the remote setpoint mode. Hold in the SETPOINT SELECT key until RSP appears in the lower display then release the key to select remote setpoint.

Switching between automatic and manual mode on either loop will not affect the internal Cascade indication.

## 4.10 Operating Two Loops of Control

Operation of two individual loops of control is identical to operating a single loop of control except that TUNING 2 group applies to Loop 2 only and two PID sets, 3 and 4, are available. TUNING group applies to Loop 1 with PID sets 1 and 2 applicable.

### Operating Modes and Setpoint Source

The rules for Auto/Manual modes and changing setpoint sources are the same as single loop operation.

### Keyboard Operation

Note that the loop being displayed is the only loop affected by normal keyboard operation. However, either loop can be reconfigured when in the Set Up mode regardless of which is being displayed during normal operation.

### Accutune

Two independent loops can be tuned at the same time, if configured. For Cascade applications the secondary loop (Loop1) should be tuned first, then the primary loop (Loop 2) should be tuned with Loop 1 in the Cascade Automatic Mode. For more details on Accutune, see *Section 4.15*.

### Setpoint Ramp or SP Programming

Either loop or both loops can be configured for a single setpoint ramp operation by enabling the desired loop or loops (see *Section 3 – Configuration*).

An "H" for Hold or "R" for Run will appear when applicable in the left-most character in the upper display, depending upon which loop is being displayed.

The RUN/HOLD operation is shown in Table 5-1.

### Digital Inputs (Remote Mode Switching)

Digital Input 1 is dedicated to Loop 1 and Digital Input 2 is dedicated to Loop 2 when two loops or Cascade control is configured. Otherwise, both DI's apply to single loop configurations.

## Output Override Hi/Lo Select

Output Override allows you to select the higher of Output 1 and Output 2 (Hi Select) or the lower of Output 1 and Output 2 (Lo Select) to appear at Output 1 terminals to drive the final control element. Refer to *Section 4.8* for Override rules.

Override prompts appear under the Algorithm Set Up group, function prompt OUT OVRD.

## 4.11 Three Position Step Control Algorithm

The Three Position Step Control algorithm (Loop 1 only) allows the control of a valve (or other actuator) with an electric motor driven by two controller output relays; one to move the motor upscale, the other to move it downscale, without a feedback slidewire linked to the motor shaft. Accutune **SP** or **SP+PV** tuning does not function with this algorithm. Accutune **TUNE** will operate with this algorithm.

### Displaying the Motor Position

**Table 4-18 Procedure for Displaying the 3PSTEP Motor Position**

Step	Operation	Press	Action
1	Access the displays	<b>LOWER DISPLAY</b>	until you see the PV Value in the Upper Display and either POS or OUT in the Lower Display.

## 4.12 Input Math Algorithms

If selected via Math options, this controller has two input algorithms available. Each algorithm can be configured to provide a derived (calculated) PV or a derived remote setpoint. Up to three inputs may be applied to the calculation. In addition, the two algorithms may be “linked” to combine two calculations by configuring one algorithm to be an input to the other algorithm.

Standard functionality:

- Basic models (DC330B) contain as standard: Weighted Average, Feedforward Summer, Feedforward Multiplier.
- Expanded models (DC330E) provide as standard: Weighted Average, Feedforward Summer, Feedforward Multiplier, Relative Humidity.

The Math option, which provides additional algorithms plus two Characterizers, Totalizer, and Gain Scheduling, is available only on Expanded Model DC330E-XX-XXX.

## Input Algorithm Selections

Algorithm selections are made in *Section 3 – Configuration*. The following function prompts can be found in the Algorithm Set Up group:

IN ALG1  
IN ALG2 These selections include the following algorithms:  
Weighted Average  
Feedforward Summer  
Relative Humidity  
Summer  
Hi Select  
Lo Select  
√ Multiply Divide  
√ Multiply  
Multiply Divide  
Multiply  
Feedforward Multiplier  
Carbon Potential (several types)  
Dewpoint

Input A, Input B, and Input C selections for these formulas are found in *Section 3 – Configuration*; Set Up group ALGORITHM, under the following function prompts:

ALG1 INA  
ALG1 INB  
ALG1 INC  
ALG2 INA  
ALG2 INB  
ALG2 INC

## 8-Segment Characterization

This is available as part of the Math Algorithm option. Two 8- selections can made in *Section 3 – Configuration*; Set Up group ALGORITHM, under function prompts:

8SEG CH1  
Xn VALUE  
Yn VALUE  
8SEG CH2  
Xn VALU2  
Yn VALU2

An 8-segment characterizer can be applied to either Input 1, Input 2, Output 1, or Output 2. When Input 1 or Input 2 is used, the selected input's Ratio and Bias are applied to the Xn values.

When one of the loop outputs is selected, the Xn Values are the output from the control algorithm, and the Yn Output is the final control element action.

## Totalizer Function

A **Flow Totalizer** is available as part of the Math Algorithm option. This calculates and displays the total flow volume being measured by Input 1. Alternatively, it can be applied to either Input Algorithm 1 or Input Algorithm 2 to totalize the compensated flow rate being calculated by the algorithm.

The **totalizer displays** the current totalized flow value (up to seven digits maximum). Seven **scaling factors** are available (from one to one million). The desired scaling factor is applied to the calculated value to extend the maximum total flow range that can be displayed.

**Five integration rates** are available to match the totalizer rate to the rate of flow being measured. The rates are:

- Engineering units (EU) per second
- EU per minute
- EU per hour
- EU per day
- Millions of units per day

The totalizer value is stored in nonvolatile memory once every eight hours. If **power is lost** while the totalizer is in operation, the current value of the totalizer will be lost. When **power is restored**, the totalizer will start operation for the last value stored in nonvolatile memory. The  $\Sigma$  (**Sigma**) display will blink to indicate this condition. Reset the totalizer.

The totalizer can be **reset** from the keyboard whenever desired. The totalizer should always be reset to initialize the counters whenever it is enabled, otherwise, the “ $\Sigma$ ” (Sigma) display will blink.

Refer to *Section 3 – Configuration*, Set Up group ALGORITHM, function prompt TOTALIZER to select an application, and the function prompts that follow TOTALIZER to enter your scale factor and rate of integration.

## Alarm on Totalizer Value

The alarm type configuration includes an Alarm on Totalizer value. This allows an alarm setpoint value to be used to cause an alarm when exceeded. The alarm setpoint represents the lowest four digits of the selected Totalizer Scale Factor and has a range from 0 to 9999 x Totalizer Scale Factor.

## Totalizer Reset Via Digital Input

The digital input type configuration includes a Reset Totalizer that resets the accumulated totalizer value when the DI is closed.

### 4.13 Digital Input Option (Remote Switching)

The Digital Input option detects the state of external contacts for either of two inputs. On contact closure, the controller will respond according to how each digital input is configured. Make your selection under the Options Set Up group function prompt "DIG IN1" or "DIG IN2." See *Section 3 – Configuration*.

**Table 4-19 Digital Input Option Action on Contact Closure**

DIG IN1 or DIG IN2 Selections	Display Indication	Action on Contact Closure Returns (toggles) to original state when contact opens, unless otherwise noted.
None	DI 1 2 always off*	No Digital Input selection
TO MAN	MAN blinks	Puts the controller into manual mode.
TO LSP		Puts the controller into local setpoint 1.
TO 2SP	RSP annunciator blinks	Puts the controller into local setpoint 2.
TO 3SP	RSP annunciator blinks	Puts the controller into local setpoint 3.
TO DIR		Selects direct controller action.
ToHOLD	H blinks	Suspends setpoint program or setpoint ramp operation.
ToPID2	PIDSET 2 in lower display	Selects PID set 2.
PV 2IN	II (II blinks) IN	Selects the PV to equal Input 2.
PV 3IN	III (III blinks) IN	Selects the PV to equal Input 3.
RERUN		Resets the Setpoint Program back to the beginning of the first segment in the program and leaves the program in the same Run Or Hold mode that it was in when the DI closed. Opening the DI has no further effect.
TO RUN	R indicator blinks	Starts a stopped SP Program.
ToBEGN		Resets the Setpoint Program back to the beginning of the first segment in the program and places the program into the Hold mode.
STOP I		Disables PID Integral (I) action.
MAN FS	MAN blinks	Unit goes to manual mode, output goes to the failsafe value.



DIG IN1 or DIG IN2 Selections	Display Indication	Action on Contact Closure Returns (toggles) to original state when contact opens, unless otherwise noted.
ToLOCK	LOCKED when a key is pressed	Disables all keys.
ToAout		Output is forced to value set at control prompt "AUTO OUT" when controller is in automatic mode.
TIMER	Timer clock (  ) and time appear in lower display.	Starts timer (momentary). Reopening switch has no effect.
AM STA		Causes switch to Auto Manual Station mode.
ToTUNE	TUNE ON in lower display	Starts the Accutune process.
SPinit		Forces the SP to initialize at the current PV value.
TRACK1	O blinks	Allows Output 1 to track Input 2.
TRACK2	O blinks	Allows Output 2 to track Input 2.
ToOUT2	O blinks	Allows Output 2 to override Input 1.
TO RSP	RSP annunciator blinks	Selects remote setpoint, if enabled.
D L1/2		Displays loop not being displayed at time of closure.
RST FB		Allows Input 2 to override the internal reset value, providing external reset feedback.
ToPURG	MAN blinks and output value shows in lower display	Forces loop to manual mode with the output values set to the Output High Limit configuration.
LoFIRE	MAN blinks and output value shows in lower display	Forces loop to manual mode with the output set to the Output Low Limit configuration.
MAN LT		Forces loop to manual mode, latched. Opening DI has no effect on Mode. UDC remains in manual mode.
REStot		Resets the accumulated totalizer value. Opening the switch has no effect.

### Keyboard Operation

Front panel keys have no effect on the digital input action in the closed state.

## Digital Inputs 1 and 2 Combination Selections

Table 4-20 Digital Input Combinations “DIG IN1” or “DIG IN2”

Selections used in Combination with “DIG IN1” or “DIG IN2”	Display Indication	Action on contact closure Returns (toggles) to original state when contact opens.
+PID2	PIDSET 2 in lower display	Selects PID set 2.
+ToDIR		Puts the controller into direct action.
+ToSP2	RSP blinks	Selects the second local setpoint.
+DISAT	T indicator is no longer lit	Disables Adaptive tune.
+ToSP1		Selects the local setpoint.
+RUN	R indicator blinks	Starts or restarts RUN of SP RMP/PROG.

### 4.14 Fuzzy Overshoot Suppression

Fuzzy Overshoot Suppression minimizes overshoot after a setpoint change or a process disturbance. This is especially useful in processes which experience load changes or where even a small overshoot beyond the setpoint may result in damage or lost product. It can be configured to apply to Loop 1, Loop 2, or both loops.

#### Configuration

To configure this item, refer to *Section 3 – Configuration*:

- Set Up Group **ACCUTUNE**
- Function Prompt **FUZZY**
- Select **ENABLE** or **DISABL** (▲ or ▼)

### 4.15 Accutune

There are several types of Accutune from which to choose in DC330E Models:

- **(TUNE) Demand Tuning**—Tuning is done on demand
  - by pressing the LOWER DISPLAY and ▲ keys simultaneously,
  - by selecting prompt “TUNE” in the lower display,
  - via digital input.
- **(SP) Setpoint Tuning**—SP only tuning will continually adjust the Gain or Proportional Band (P), Reset (I), and Rate (D) tuning constants in response to setpoint changes.
- **(TUN+PV) Demand Tuning + PV Adapt**—Provides TUNE On Demand tuning plus PV adaptive tuning whenever a PV process disturbance of 0.3% span or greater occurs.
- **(SP+PV) Setpoint Tuning + PV Adapt**—Provides SP only tuning plus PV adaptive tuning whenever a PV process disturbance of 0.3% span or greater occurs.

## Configuration

To configure this item, refer to *Section 3 – Configuration*.

## Two-loop and Cascade Operation

Accutune can be used on either or both loops. However, while one loop is operating by **SP** tuning, the configuration of either loop cannot be changed. When one loop is operating by **PV** adaptive tuning, the other loop can have its configuration changed.

## Rules

**Table 4-21 Accutune Rules and Regulations**

TUNE	SP	Applicable Rule
X		<b>TUNE</b> On Demand tuning will work for all control algorithms except ON/OFF. Process line out is not required.
X		<b>TUNE</b> On Demand tuning works for integrating processes.
	X	<b>SP</b> tuning will work only for algorithm PID a or PID B selections; i.e., it will <b>NOT</b> work with ON/OFF, Three Position Step, or PD+MR control algorithms.
	X	<b>SP</b> tuning can tune on all local or computer setpoints <i>except ramping setpoints</i> ; i.e., cannot be done during SP Ramp or SP Program or when using remote setpoint.
X	X	Tuning is done in automatic mode.
X	X	Tuning can be monitored or reconfigured using communications option.
X	X	Tuning can be enabled via digital inputs.
X	X	Tuning can be aborted by going to manual mode or disabling via configuration.
X	X	When tuning is in progress, a large <b>T</b> appears in the upper display and disappears as soon as tuning is completed.
X	X	Can tune two independent loops.
X		Setpoint changes can be made during operation. The setpoint at the time tuning starts is captured and Tune runs until completion, then proceeds to the new SP value following the completion of tuning.

### Starting TUNE (Demand Tuning)

After TUNE or TUN+PV has been enabled use the following procedure to start tuning.

**Table 4-22 Procedure for Starting TUNE (Demand) Tuning**

Step	Action
1	Set the setpoint to the desired value.
2	Switch to Automatic mode by pressing the Manual/Auto key.
3	Initiate Tuning by: <ul style="list-style-type: none"><li>• pressing the ▲ key when the lower display prompt = TUNE-OFF,</li><li>• pressing the Lower Display and ▲ keys simultaneously, or</li><li>• using the digital input, if configured.</li></ul>

---

### Aborting Tuning

If it is necessary to stop or abort the tuning process, press the MANUAL/AUTO key and the controller will return to manual mode. You can also disable TUNE or TUN+PV in the ACCUTUNE or ACCUTUN2 Set Up group

### Tune for Duplex (Heat/Cool)

TUNE can be done for applications using duplex (heat/cool) control. During tuning, Accutune requires that **setpoint 1** will cause a Heating demand, and then the calculated tuning parameters will be automatically entered as PID set 1. Likewise, it requires that tuning at local **setpoint 2** will cause a Cooling demand, and then the cooling parameters will be entered as PID set 2.

The tuning sequence will cycle the controller's output two full cycles between the high output limit and 50% for HEAT or between 50% and the low output limit for COOL while allowing only a small process variable change above and below the setpoint during each cycle.

### Configuring TUNE for Duplex (Heat/Cool)

To configure this item, refer to *Section 3 – Configuration*.

## Using TUNE at Start-Up for Duplex (Heat/Cool)

**Table 4-23 Procedure for Using TUNE at Start-up for Duplex**

Step	Action
1	<p><b>Heat Zone:</b></p> <ul style="list-style-type: none"> <li>• Adjust <b>Local Setpoint 1</b> to a value within the <b>Heat</b> zone.</li> <li>• Put the controller in <i>Automatic</i> mode.</li> <li>• Press the Lower Display and ▲ keys simultaneously to initiate <b>Heat</b> tuning.</li> </ul> <p>The output will cycle between 50% and 100% (or high output limit). A large <b>T</b> appears in the upper display until tuning is completed and final <b>Heat</b> parameters are entered for <b>PID set 1</b> in the Tuning group.</p>
2	<p><b>Cool Zone:</b></p> <ul style="list-style-type: none"> <li>• Adjust <b>Local Setpoint 2</b> to a value within the <b>Cool</b> zone.</li> <li>• Put the controller in <i>Automatic</i> mode.</li> <li>• Press the Lower Display and ▲ keys simultaneously to initiate <b>Cool</b> tuning.</li> </ul> <p>The output will cycle between 0% and 50% (or low output limit). A large <b>T</b> appears in the upper display until tuning is completed and final <b>Cool</b> parameters are entered for <b>PID set 2</b> in the Tuning group.</p>

## Using SP Tuning at Start-Up

**Table 4-24 Procedure for Using SP Tuning at Start-Up**

Step	Action
1	Put the controller in manual mode by pressing the MANUAL/AUTO key.
2	Let the PV stabilize.
3	Adjust the setpoint to the desired value.
4	<p>Put the controller in automatic mode by pressing the MANUAL/AUTO key.</p> <p>The controller will switch to automatic mode and the process will start to move toward the setpoint and will line out with the proper tuning constants. A large <b>T</b> appears on the left side of the upper display to indicate that SP tuning is in progress.</p>

## SP Tuning for Duplex (Heat/Cool)

SP tuning can be done for applications using duplex (heat/cool) control.

## Configuring SP Tuning for Duplex (Heat/Cool)

To configure this item, refer to *Section 3 – Configuration*.

### SP Tuning After Start-Up

SP tuning will occur whenever the controller is in automatic mode and a setpoint change occurs which is greater than the previously configured minimum setpoint change value.

The controller will delay using any setpoint changes for 30 seconds to enable it to calculate whether to SP tune or not. But if the controller is toggled between LSP1 and LSP2 or if any other key (such as LOWER DISPLAY) is pressed, the setpoint change is immediate.

A large **T** is displayed in the upper display whenever tuning is in progress. During this time, no changes to the configuration parameters, including the setpoint, are permitted.

### Aborting SP Tuning

If it is necessary to stop or abort the tuning:

- Press the MANUAL/AUTO key to return to manual mode. This will cause an immediate abort of tuning.
- Disable SP or SP+PV in the Accutune Set Up group at function prompt ACCUTUNE or ACCUTUN2.

### Retuning

The controller will evaluate current tuning as SP changes occur. When retuning is required, the controller operates in automatic mode and identifies new tuning constants. At the point, the **T** appears and tuning values are entered and used until retuning occurs again.

### TUN+PV or SP+PV (Process Variable Disturbance)

The TUNE demand tuning or the SP tuning portions of these selections work as stated previously.

During process variable (PV) disturbances which result from non-linearities, process dynamics, load changes, or other operating conditions, PV adapt tuning will occur whenever a PV disturbance of 0.3 % span or larger occurs. When this condition exists, the controller monitors the process response to determine whether there has been a true process change or a momentary upset. It will take 1 and 1/2 process cycles around the setpoint before any process recognition can occur to an oscillating process.

However, if no oscillation occurs, Adaptive may alter the parameters to speed up or slow down the process response, if it determines the time to return to the SP is excessive or too fast (overshoot occurs).

For this configuration, the controller operates with only one set of tuning parameters for each loop. The second set, normally used for duplex output or for keyboard, PV or SP switching, is not used because Adaptive tune continually updates the tuning parameters based on the PV deviation.

## PV Tuning Indications

A small **t** is displayed in the upper display whenever PV adapt mode is in progress. During this time, changes to the configuration parameters are permitted. Whenever the **t** is displayed it signifies that the process response is being monitored and this may or may not result in parameter retuning.

The selection of Fast or Normal criteria has no effect on PV adaptive tuning.

## Aborting PV Adaptive Tuning

If it is necessary to stop or abort the tuning:

- Press the MANUAL/AUTO key to return to manual mode. This will cause an immediate abort of tuning.
- Disable TUN+PV or SP+PV in the Accutune Set Up group at function prompt ACCUTUNE or ACCUTUN2.

## 4.16 Entering a Security Code

The level of keyboard lockout may be changed in the Set Up mode. However, knowledge of a security code number (0 to 4095) may be required to change from one level of lockout to another. When a controller leaves the factory, it has a security code of 0, which permits changing from one lockout level to another without entering any other code number.

If you require the use of a security code, select a number from 0001 to 4095 and enter it when the lockout level is configured as NONE. Thereafter, that selected number must be used to change the lockout level from something other than NONE.

**CAUTION** Write the number on the Configuration Record Sheet in Appendix C so you will have a permanent record.

**Table 4-25 Procedure to Enter a Security Code**

Step	Operation	Press	Result
1	Enter Set Up Mode	<b>SET UP</b>	Upper Display = <b>SET UP</b> Lower Display = <b>TUNING</b>
2	Select any Set Up Group	<b>FUNCTION LOOP 1/2</b>	Upper Display = <b>0</b> Lower Display = <b>SECUR</b>
3	Security Code Entry	<b>▲</b> or <b>▼</b>	To enter a four digit number in the upper display (0001 to 4095) This will be your security code.

## 4.17 Carbon Potential

A carbon probe consisting of a ZrO<sub>2</sub> sensor and a thermocouple (to measure the temperature at the sensor) provides two inputs to the controller. The controller computes the atmosphere's actual carbon potential from these two inputs and compares the computed value with the desired setpoint. An on-off or PID control algorithm determines the controller output necessary to keep the actual carbon potential at the setpoint. Usually only one output is used to add more or less enriching gas (typically natural gas) to the furnace's base atmosphere, which has a relatively low carbon potential.

The enriching gas then raises the carbon potential to the desired level; however, there are occasions when it is necessary to add dilution air to lower the carbon potential instead of enriching gas to raise it. In those instances, a second output from the controller provides this function. When proportional control is used, a different set of PID tuning constants is used for the dilution air than those used for the enriching gas.

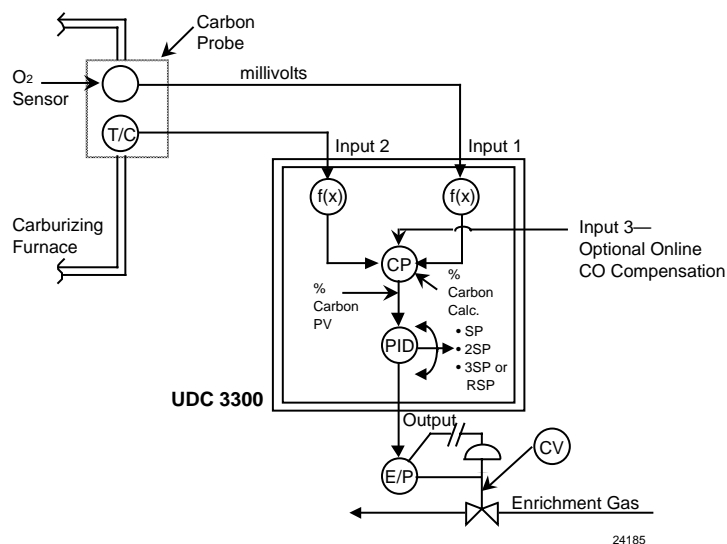

**Figure 4-3 UDC3300 Controller Being Used to Control the Carbon Potential of a Furnace's Atmosphere**

The following rules apply for Carbon Potential control

- For Carbon control, set Input Algorithm 1 to the proper carbon sensor used and set the PV source to IN AL 1. Input 1 will automatically become CARBON.
- For % Oxygen control, set Input Algorithm 1 to OXYGEN. Input 1 will automatically become OXYGEN.
- For Dewpoint control, set Input Algorithm 1 or Input Algorithm 2 to DEW PT. Input 1 will automatically become CARBON. The availability of Dewpoint on Input Algorithm 2 provides the capability of controlling Carbon Potential on Loop 1 and also reading the Dewpoint value from the same probe.
- CO Compensation—Receives external CO transmitter signal via Input 3 to provide online compensation of the carbon calculation. Requires that the Input 2 temperature signal be a transmitter type input.



## 4.18 Health Watch

The HealthWatch feature puts diagnostic data at your fingertips so you can monitor vital performance status to improve your process, predict failures, and minimize downtime.

Valuable data regarding maintenance and diagnostic selections can be read by operator-accessed displays. Alarms can be configured to activate when the desired threshold is reached.

See Section 3.19 for details on configuring the various HealthWatch timers and counters. See Section 3.16 for details on HealthWatch maintenance alarms.



## 5. Setpoint Rate/Ramp/Soak Program Operation

### 5.1 Setpoint Ramp Rate

#### Introduction

When you have configured a Setpoint Ramp Rate, it will apply immediately to any local setpoint change.

#### Configuration Check

Make sure you:

- enable SP RATE for either loop
- disable SP RAMP and SP PROG
- set an upscale or downscale rate value

---

**ATTENTION**

A value of 0 will imply an immediate change in setpoint; that is, NO RATE applies. See *Section 3.5* for details.

---

#### Operation

When a local setpoint change is made, the controller will ramp from the original setpoint to the new one at the rate specified. This changing (current) setpoint can be viewed as SPn on the lower display.

Press the LOWER DISPLAY key until you see SPn and the setpoint value in the lower display.

### 5.2 Single Setpoint Ramp

#### Introduction

When you have configured a single setpoint ramp, it will occur between the current local setpoint and a final local setpoint over a time interval of from 1 to 255 minutes. You can RUN or HOLD the ramp at any time.

#### Configuration Check

Make sure you:

- enable SP RAMP for either loop
- disable SP RATE and SP PROG
- set the ramp time in minutes
- set the final setpoint value

See *Section 3.5* for details.

**Operation**

Running a Setpoint Ramp includes enabling, starting, holding, viewing the ramp time, and ending the ramp.

**Table 5-1 Procedure for Running a Setpoint Ramp**

Step	Operation	Press	Action
1	Enable the Setpoint Ramp function	<b>SET UP</b>	until you see SET UP in the Upper Display and SP RAMP in the Lower Display.
		<b>FUNCTION LOOP 1/2</b>	You will see DISABL or ENABLE in the Upper Display and SP RAMP in the Lower Display
		<b>▲</b>	until you see ENABLE in the Upper Display.
2	Put the controller into Automatic mode	<b>MANUAL AUTO</b>	until "A" indicator is ON and you will see: H and the PV value in the Upper Display. SP and the present setpoint value in the Lower Display.
3	Set Start Setpoint	<b>▲ or ▼</b>	until the <b>start setpoint value</b> you desire is indicated in the lower display:
4	Start the Ramp	<b>RUN HOLD</b>	You will see R and the PV value in the Upper Display and SP and the changing setpoint value in the Lower Display.
5	Hold/Run the Ramp	<b>RUN HOLD</b>	This holds the ramp at the current setpoint value. (SP can then be changed by the <b>▲</b> and <b>▼</b> keys.)  Press again to continue run.
			<b>ATTENTION</b> Any time the local setpoint is different from the final setpoint value and the RUN/HOLD key is pressed, the ramp will start again.
6	View the remaining ramp time	<b>LOWER DISPLAY</b>	until you see: R or H and the PV value in the Upper Display. RAMP time remaining in the Lower Display.
7	End the Ramp		When the final setpoint is reached, the "R" changes to "H" in the upper display and the controller operates at the new setpoint.
8	Return to normal operating mode		After the SP Ramp has completed, disable the SP RAMP function, then press the LOWER DISPLAY key.

## 5.3 Setpoint Ramp/Soak Programming Option

### Introduction

Setpoint Ramp/Soak Programming lets you configure six ramp and six soak segments to be stored for use as one program or several small programs. You designate the beginning and end segments to determine where the program is to start and stop.

### Review Program Data and Configuration

The procedure for programming is straightforward and aided by prompts. We suggest that you read Table 5-2 which lists the program contents with an explanation of each to aid in configuration. Then refer to *Section 3.5 – SP Ramp, SP Rate, or SP Programming Set Up Group* to enable and configure the setpoint program.

---

**ATTENTION**

SP RATE and SP RAMP must be disabled to enable SP PROG (Setpoint Programming).

---

### Fill Out the Worksheet

Referring to the example in Figure 5-1, draw a Ramp/Soak Profile on the worksheet provided in Figure 5-2 and fill in the information for each segment. This will give you a record of how the program was developed.

### Operation

See Table 5-3 to run/monitor the program.

### Power Outage

---

**ATTENTION**

If power is lost during a program, upon power-up the controller will be in hold and the setpoint value will be the setpoint value prior to the beginning of the setpoint program. The program is placed in hold at the beginning of the first segment in the program. The mode will be as configured under PWR MODE in the Control function group. (This applies to both loops.)

---

**Table 5-2 Program Contents**

Contents	Definition
<b>Ramp Segments</b>	<p>A ramp segment is the time it will take to change the setpoint to the next setpoint value in the program.</p> <ul style="list-style-type: none"> <li>• Ramps are odd number segments.</li> <li>• Ramps are configured in either Time or Engineering Units per Minute or Engineering Units per Hour (see Ramp Unit below.)</li> </ul> <p>NOTE: Entering "0" will imply an immediate step change in setpoint to the next soak.</p>
<b>Ramp Unit</b>	<p>The Ramp Unit selection determines the engineering data units for the ramp segments. The selections are:</p> <ul style="list-style-type: none"> <li>• TIME = Hours:Minute (XX:XX) (<i>Range:</i> 0-99 hrs:0-59 min.)</li> <li>• EU/MIN = Degrees/Minute <b>or</b> EU/HR = Degrees/Hour (<i>Range:</i>0 to 999)</li> </ul>
<b>Soak Segments</b>	<p>A Soak Segment is a combination of soak setpoint (value) and a soak duration (time).</p> <ul style="list-style-type: none"> <li>• Soaks are even number segments.</li> <li>• The soak setpoint range value must be within the setpoint high and low range limits in engineering units.</li> <li>• Soak time is the duration of the soak and is determined in: TIME – Hours.Minutes      <i>Range:</i> 0-99hrs.59min.</li> </ul>
<b>Start Segment</b>	<p>This designates the number of the first segment (Odd number). <i>Range:</i> 1 to 11</p>
<b>End Segment</b>	<p>This designates the number of the last Soak segment (Even Number). <i>Range:</i> 2 to 12</p>
<b>Recycle Number</b>	<p>This number allows the program to recycle to a specified number of times from beginning to end.      <i>Range:</i> 0 to 99</p>
<b>Guaranteed Soak</b>	<p>Each soak segment can have a deviation value of from 0 to ±99 which guarantees the value for that segment. The value is the number in engineering units, above or below the setpoint, out side of which the timer halts.      <i>Range:</i> 0 to ±99</p> <p>Soak deviation values &gt;0 guarantee that the soak segment's process variable is within the ± deviation for the configured soak time. Whenever the ± deviation is exceeded, soak timing is frozen.</p> <p>The guaranteed soaks feature is disabled whenever the deviation value is configured to 0.</p>
<b>Program State</b>	<p>This selection determines whether the program is in the Hold state or Disabled after completion of the program.</p>
<b>Program Termination State</b>	<p>This function determines the status of the controller upon completion. The selections are:</p> <ul style="list-style-type: none"> <li>• LASTSP = controls to last setpoint and last control mode</li> <li>• F SAFE = manual mode, failsafe output</li> </ul>

Contents	Definition
<b>Hot Start</b>	This function determines whether LSP1 or PV is used as the setpoint when the program is initially changed from HOLD to RUN. The selections are: <ul style="list-style-type: none"><li>• DISABL = present LSP1 is default setpoint</li><li>• ENABL = present PV value is used as beginning setpoint value for the ramp segment</li></ul>
<b>Reset Program to Beginning</b>	When enabled, this selection allows you to reset the program to the beginning or rerun it from the keyboard.

---

## Setpoint Rate/Ramp/Soak Program Operation

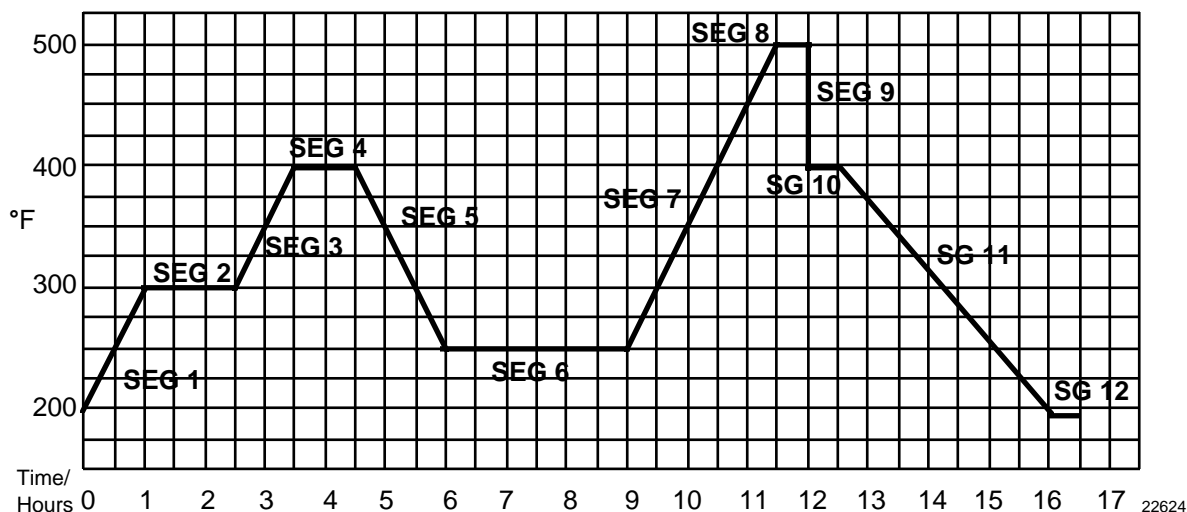

**Figure 5-1 Ramp/Soak Profile Example**

Prompt	Function	Segment	Value	Prompt	Function	Segment	Value
STRT SEG	Start Seg.		1	SEG4TIME	Soak Time	4	1 hr.
END SEG	End Seg.		12	SEG5RAMP	Ramp Time	5	1hr.:30 min.
RAMP UNIT	Engr. Unit for Ramp		TIME	SEG6 SP	Soak SP	6	250
RECYCLES	Number of Recycles		2	SEG6TIME	Soak Time	6	3hrs.:0min.
SOAK DEV	Deviation Value		0	SEG7RAMP	Ramp Time	7	2hrs.:30min.
PROG END	Controller Status		LAST SP	SEG8 SP	Soak SP	8	500
STATE	Controller State at end		HOLD	SEG8TIME	Soak Time	8	0hr.:30 min.
KEYRESET	Reset SP Program		DISABL	SEG9RAMP	Ramp Time	9	0
HOTSTART	PV Hot Start Program Initialization or power up in SPP		DISABL	SG10 SP	Soak SP	10	400
SEG1RAMP	Ramp Time	1	1 hr.	SG10 TIME	Soak Time	10	0hr.:30 min.
SEG2 SP	Soak SP	2	300	SG11RAMP	Ramp Time	11	3hrs.:30min.
SEG2TIME	Soak Time	2	1hr.:30 min.	SG12 SP	Soak SP	12	200
SEG3RAMP	Ramp Time	3	1hr.	SG12TIME	Soak Time	12	0hr.:30 min.
SEG4 SP	Soak SP	4	400				



**Program Record Sheet**

Draw your ramp/soak profile on the record sheet shown in Figure 5-2 and fill in the associated information in the blocks provided. This will give you a permanent record your program and will assist you when entering the setpoint data.

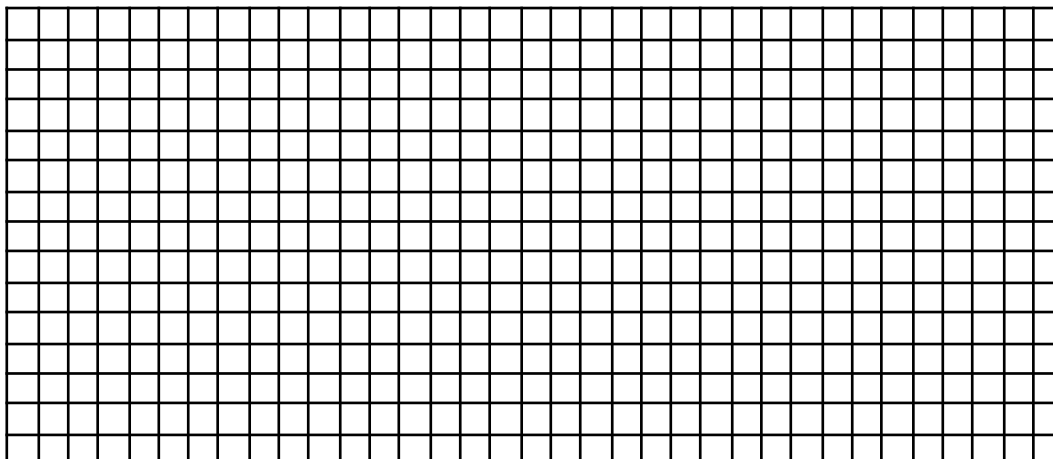

22625

**Figure 5-2 Program Record Sheet**

Prompt	Function	Segment	Value
STRT SEG	Start Seg.		
END SEG	End Seg.		
RAMPUNIT	Engr. Unit for Ramp		
RECYCLES	Number of Recycles		
SOAK DEV	Deviation Value		
PROG END	Controller Status		
STATE	Controller State at end		
KEYRESET	Reset SP Program		
HOTSTART	PV Hot Start Program Initialization or power up in SPP		DISABL
SEG1RAMP	Ramp Time	1	
SEG2 SP	Soak SP	2	
SEG2TIME	Soak Time	2	
SEG3RAMP	Ramp Time	3	
SEG4 SP	Soak SP	4	
SEG4TIME	Soak Time	4	
SEG5RAMP	Ramp Time	5	
SEG6 SP	Soak SP	6	
SEG6TIME	Soak Time	6	
SEG7RAMP	Ramp Time	7	
SEG8 SP	Soak SP	8	
SEG8TIME	Soak Time	8	
SEG9RAMP	Ramp Time	9	
SG10 SP	Soak SP	10	
SG10 TIME	Soak Time	10	
SG11RAMP	Ramp Time	11	
SG12 SP	Soak SP	12	
SG12TIME	Soak Time	12	

**Run/Monitor Functions**

Table 5-3 lists all the functions required to run and monitor the program.

**Table 5-3 Run/Monitor Functions**

Function	Press	Result
Set the Local Setpoint	<b>SETPOINT SELECT</b>	<i>Lower Display: SP</i>
	▲ or ▼	to set the Local Setpoint value to where you want the program to start out.
Run State	<b><u>RUN</u> HOLD</b>	Initiates the setpoint program. An "R" appears in the upper display indicating that the program is running.
Hold State	<b><u>RUN</u> HOLD</b>	Holds the setpoint program. An "H" appears in the upper display indicating that the program is in the HOLD state.  The setpoint holds at the current setpoint.
External Hold  DI = "To HOLD"		If Remote Switching (Digital Input option) is present on your controller, contact closure places the controller in the HOLD state, if the setpoint program is running. The "H" in the upper display will blink indicating external hold is in effect. Contact reopening runs program.  NOTE: The keyboard takes priority over external switch for the RUN/HOLD function.
Changing a Segment While in Hold	▲ or ▼	These keys will operate and allow you to change the segment number while in HOLD. If a different segment is selected, it will be started at the beginning when placed in RUN. If the original segment is brought back, the program will continue from the point placed in HOLD.  NOTE: Changing a segment number may affect the alarms/events.
External Program Reset  "To BEGN"	<b><u>RUN</u> HOLD</b>	If Remote Switching (Digital Input option) is present on your controller, contact closure resets the SP Program back to the start of the first segment. Program cycle number is not affected.  Reopening the contact has no effect and places the program in HOLD mode.  The setpoint is changed to what the setpoint was when the program was first started.  restarts the Setpoint Program.

Function	Press	Result
Keyboard Reset	<b>LOWER DISPLAY</b>	until you see <i>Lower Display:</i> ToBEGN Press ▲ key to reset program to beginning at Hold state.
Viewing the Present Ramp or Soak Segment Number and Time	<b>LOWER DISPLAY</b>	until you see <i>Upper Display:</i> "R" and the PV value <i>Lower Display:</i> Ramp segments: # RA XX.XX Soak segments: # SK XX.XX # indicates the segment number (Ramp–odd only, Soak–even only) XX.XX Ramp Time – Hours.Minutes Ramp Rate – EU/MIN or EU/HR Soak Time – Hours.Minutes
Viewing the Number of Cycles Left in the Program	<b>LOWER DISPLAY</b>	until you see <i>Upper Display:</i> "R" and the PV value <i>Lower Display:</i> RECYC XX Number of cycles remaining in the setpoint program. XX = 0 to 99
End Program		When the final segment is completed, the "R" in the upper display either changes to "H" (if configured for HOLD state) or disappears (if configured for disable of setpoint programming). The controller operates at the last setpoint in the program in automatic or will be in manual mode at the failsafe output.
Disable Program		See <i>Section 3.5</i> for details.

---



## 6. Appendix A – Environmental and Operating Conditions

Parameter	Reference	Rated	Operative Limits	Transportation and Storage
<b>Ambient Temperature</b>	25 °C ± 3 °C 77 °F ± 5 °F	15 °C to 55 °C 58 °F to 131 °F	0 °C to 55 °C 32 °F to 131 °F	–40 °C to 66 °C –40 °F to 151 °F
<b>Relative Humidity</b>	10 to 55*	10 to 90*	5 to 90*	5 to 95*
<b>Vibration</b>				
Frequency (Hz)	0	0 to 70	0 to 200	0 to 200
Acceleration (g)	0	0.4	0.6	0.5
<b>Mechanical Shock</b>				
Acceleration (g)	0	1	5	20
Duration (ms))	0	30	30	30
<b>Voltage (Vdc)</b>	+24 ± 1	20 to 27	20 to 27	--
<b>Voltage (Vac)</b>				
<b>90 to 240 Vac</b>	120 ± 1 240 ± 2	90 to 240	90 to 264	-- --
<b>24 Vac</b>	24 ± 1	20 to 27	20 to 27	--
<b>Frequency (Hz)</b>	50 ± 0.2	49 to 51	48 to 52	--
(For Vac)	60 ± 0.2	59 to 61	58 to 62	--
<b>Power Consumption</b>	18 VA maximum (90 to 264 Vac) 12 VA maximum (24 Vac/dc)			
<b>Input Accuracy</b>	± 0.20 % of span typical (± 1 digit for display) Field calibratable to ± 0.05 % of span typical 15-bit resolution typical			
<b>CE Conformity Special Conditions (Europe)</b>	Shielded twisted pair cables are required for all analog I/O, process variable, RTD, thermocouple, dc millivolt, low level signal, 4-20 mA, digital I/O, and computer interface circuits.			

\* The maximum rating only applies up to 40 °C (104 °F). For higher temperatures, the RH specification is derated to maintain constant moisture content.



## 7. Appendix B – Model Selection Guide

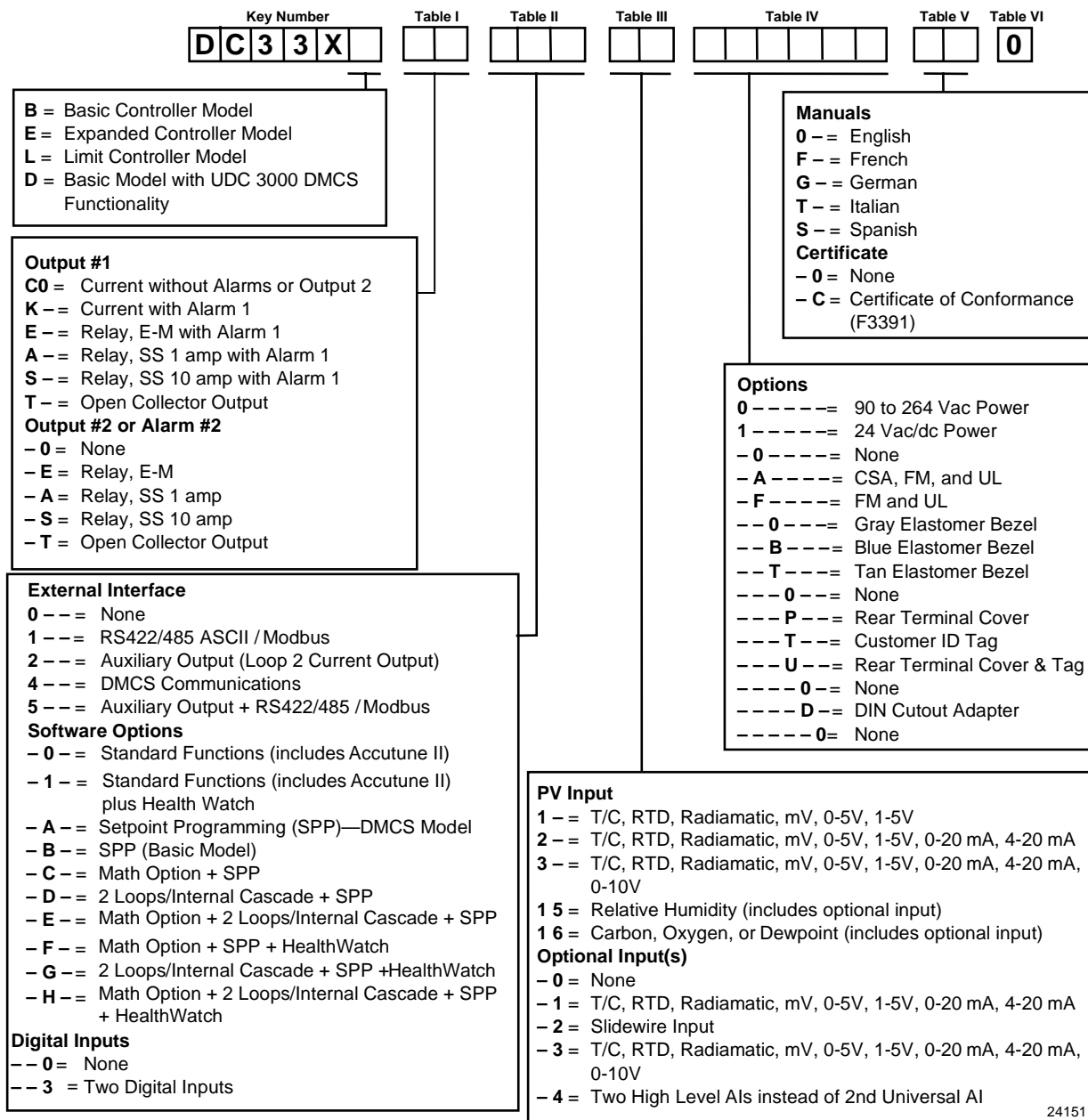

24151





## 8. Appendix C – Configuration Record Sheet

Enter the value or selection for each prompt on this sheet so you will have a record of how your controller was configured.

Group Prompt	Function Prompt	Value or Selection	Factory Setting	Group Prompt	Function Prompt	Value or Selection	Factory Setting	
TUNING	PROP BD	_____	—	TUNING2	PROPBD3	_____	—	
	or				or			
	GAIN	_____	1.000		GAIN 3	_____	1.000	
	or				or			
	GAINVALn	Read Only	—		GAINVALn	Read Only	—	
	RATE MIN	_____	0.00		RATE3MIN	_____	0.00	
	RSET MIN	_____	1.00		RSET3MIN	_____	1.00	
	or				or			
	RSET RPM	_____	—		RSET3RPM	_____	—	
	MAN RSET	_____	0		MANRSET3	_____	0	
	PROPBD2	_____	—		PROPBD4	_____	—	
	or				or			
	GAIN 2	_____	1.000		GAIN 4	_____	1.000	
	RATE2MIN	_____	0.00		RATE4MIN	_____	0.00	
	RSET2MIN	_____	1.00		RSET4MIN	_____	1.00	
	or				or			
	RSET2RPM	_____	—		RSET4RPM	_____	—	
	CYC SEC	_____	20		CYC3 SEC	_____	20	
	or				or			
	CYC SX3	_____	20		CYC3 SX3	_____	20	
	CYC2 SEC	_____	20		CYC4 SEC	_____	20	
	or				or			
	CYC2 SX3	_____	20		CYC4 SX3	_____	20	
	SECURITY	_____	0		PVEUVAL1	_____	0	
	LOCKOUT	_____	CALIB		PVEUVAL2	_____	0	
	AUTO MAN	_____	ENABLE		PVEUVAL3	_____	0	
	SP SEL	_____	ENABLE		PVEUVAL4	_____	0	
	RUN HOLD	_____	ENABLE		PVEUVAL5	_____	0	
	PVEUVAL1	_____	0		PVEUVAL6	_____	0	
	PVEUVAL2	_____	0		PVEUVAL7	_____	0	
	PVEUVAL3	_____	0		PVEUVAL8	_____	0	
	PVEUVAL4	_____	0		GAINVAL1	_____	1.000	
PVEUVAL5	_____	0	GAINVAL2	_____	1.000			
PVEUVAL6	_____	0	GAINVAL3	_____	1.000			
PVEUVAL7	_____	0	GAINVAL4	_____	1.000			
PVEUVAL8	_____	0	GAINVAL5	_____	1.000			
GAINVAL1	_____	1.000	GAINVAL6	_____	1.000			
GAINVAL2	_____	1.000	GAINVAL7	_____	1.000			
GAINVAL3	_____	1.000	GAINVAL8	_____	1.000			
GAINVAL4	_____	1.000						
GAINVAL5	_____	1.000						
GAINVAL6	_____	1.000						
GAINVAL7	_____	1.000						
GAINVAL8	_____	1.000						

Configuration Record Sheet

Group Prompt	Function Prompt	Value or Selection	Factory Setting	Group Prompt	Function Prompt	Value or Selection	Factory Setting
SP RAMP	SP RAMP	_____	DISABL		PCTH2	_____	1.0
	TIME MIN	_____	3		8SEG CH1	_____	DIASBL
	FINAL SP	_____	1000		X0 VALUE	_____	0
	PV	_____	DISABL		X1 VALUE	_____	0
	HOTSTART	_____			X2 VALUE	_____	0
	SP RATE	_____	DISABL		X3 VALUE	_____	0
	EU/HR UP	_____	0		X4 VALUE	_____	0
	EU/HR DN	_____	0		X5 VALUE	_____	0
	EU/HRUP2	_____	0		X6 VALUE	_____	0
	EU/HRDN2	_____	0		X7 VALUE	_____	0
	SP PROG	_____	DISABL		X8 VALUE	_____	0
					Y0 VALUE	_____	0
ACCUTUNE	FUZZY	_____	DISABL		Y1 VALUE	_____	0
	ACCUTUNE	_____	DISABL		Y2 VALUE	_____	0
	ACCUTUN2	_____	DISABL		Y3 VALUE	_____	0
	SP CHANG	_____	10		Y4 VALUE	_____	0
	KPG	_____	1.00		Y5 VALUE	_____	0
	SP CHAN2	_____	10		Y6 VALUE	_____	0
	KPG 2	_____	1.00		Y7 VALUE	_____	0
	CRITERIA	_____	FAST		Y8 VALUE	_____	0
	CRITERA2	_____	FAST		PCT H2	_____	—
	AT ERROR	Read Only			8SEG CH2	_____	DISABL
	or			X0 VALU2	_____	0	
	AT ERR 2			X1 VALU2	_____	0	
ALGORITHM	CONT ALG	_____	PID A		X2 VALU2	_____	0
	PIDLOOPS	_____	1 or 2		X3 VALU2	_____	0
	CONT2ALG	_____	PID A		X4 VALU2	_____	0
	OUT OVRD	_____	DISABL		X5 VALU2	_____	0
	TIMER	_____	DISABL		X6 VALU2	_____	0
	PERIOD	_____	0.01		X7 VALU2	_____	0
	START	_____	KEY		X8 VALU2	_____	0
	L DISP	_____	TI REM		Y0 VALU2	_____	0
	INP ALG1	_____	NONE		Y1 VALU2	_____	0
	MATH K	_____	—		Y2 VALU2	_____	0
	CALC HI	_____	—		Y3 VALU2	_____	0
	CALC LO	_____	—		Y4 VALU2	_____	0
	ALG1 INA	_____	—		Y5 VALU2	_____	0
	ALG1 INB	_____	—		Y6 VALU2	_____	0
	ALG1 INC	_____	—		Y7 VALU2	_____	0
	ALG1BIAS	_____	0.00		Y8 VALU2	_____	0
	PCO SEL	_____	DISABL		TOTALIZE	_____	DISABL
	PCT CO	_____	0.200		ΣXXXXXXX	_____	—
	ATM PRES	_____	760.0		TOT SCAL	_____	E0
	INP ALG2	_____	NONE		TOT SEC	_____	UNLOCK
MATH K2	_____	—		Σ RSET ?	_____	NO	
CALC HI	_____	—		TOT RATE	_____	SECOND	
	CALC LO	_____	—				
	ALG2 INA	_____	—				
	ALG2 INB	_____	—				
	ALG2 INC	_____	—				
	ALG2BIAS	_____	0.00				

Group Prompt	Function Prompt	Value or Selection	Factory Setting	Group Prompt	Function Prompt	Value or Selection	Factory Setting
OUT ALG	OUT ALG	_____	CURRNT		PCT/M UP	_____	0
	4-20 RNG	_____	100PCT		PCT/M DN	_____	0
	OUT2 ALG	_____	CURRNT		OUTHILIM	_____	100
	RLYSTATE	_____	1OF2ON		OUTLoLIM	_____	0
	RLY TYPE	_____	MECHAN		I Hi LIM	_____	100.0
					I Lo LIM	_____	0.0
INPUT 1	IN1 TYPE	_____	0-10mV		DROPOFF	_____	0
	XMITTER1	_____	LINEAR		DEADBAND	_____	1.0
	ANALYT	_____	NONE		OUT HYST	_____	0.5
	IN1 HI	_____	1000		FAILMODE	_____	NO LAT
	IN1 LO	_____	0		FAILSAFE	_____	0.0
	RATIO 1	_____	1.00		MAN OUT	_____	—
	BIAS IN1	_____	0		AUTO OUT	_____	—
	FILTER 1	_____	0		PBorGAIN	_____	GAIN
	BURNOUT1	_____	NONE		MINorRPM	_____	MIN
	EMISSIV1	_____	0.00				
INPUT 2	IN2 TYPE	_____	0-10mV	CONTROL2	PV2 SRC	_____	INP 2
	XMITTER2	_____	LINEAR		FORCE MA	_____	DISABL
	ANALYT	_____	NONE		PID SETS	_____	1 ONLY
	IN2 HI	_____	1000		SW VALUE	_____	0.00
	IN2 LO	_____	0		LSP'S	_____	1 ONLY
	RATIO 2	_____	1.00		RSP SRC	_____	NONE
	BIAS IN2	_____	0		AUTOBIAS	_____	DISABL
	FILTER 2	_____	0		SP TRACK	_____	NONE
	BURNOUT2	_____	NONE		SP HiLIM	_____	1000
	EMISSIV2	_____	0.00		SP LoLIM	_____	0
INPUT 3	IN3 TYPE	_____	DISABL		ACTION	_____	REVRSE
	XMITTER3	_____	LINEAR		OUT RATE	_____	DISABL
	IN3 HI	_____	1000		PCT/M UP	_____	0
	IN3 LO	_____	0		PCT/M DN	_____	0
	RATIO 3	_____	1.00		OUTHILIM	_____	100
	BIAS 3	_____	0		OUTLoLIM	_____	0
	FILTER 3	_____	0		I Hi LIM	_____	100.0
					I Lo LIM	_____	0.0
					DROPOFF	_____	0
					DEADBAND	_____	1.0
CONTROL	PV SOURC	_____	INP 1		FAILMODE	_____	NO LAT
	PID SETS	_____	1 ONLY		FAILSAFE	_____	0.0
	SW VALUE	_____	0.00	OPTIONS	AUX OUT	_____	DISABL
	LSP'S	_____	1 ONLY		or		
	RSP SRC	_____	NONE		CUR OUT2	_____	DISABL
	AUTOBIAS	_____	DISABL		4mA VAL	_____	0.0
	SP TRACK	_____	NONE		20mA VAL	_____	0
	PWR MODE	_____	MANUAL		DIG IN 1	_____	NONE
	PWR OUT	_____	LAST		DIG1 COM	_____	DISABL
	SP HiLIM	_____	1000		DIG IN 2	_____	NONE
SP LoLIM	_____	0	DIG2 COM		_____	DISABL	
ACTION	_____	REVRSE					
OUT RATE	_____	DISABL					

**Configuration Record Sheet**

Group Prompt	Function Prompt	Value or Selection	Factory Setting	Group Prompt	Function Prompt	Value or Selection	Factory Setting	
COM	ComSTATE	_____	DISABL		A2S2 EV	_____	--	
	Com ADDR	_____	0		AL HYST	_____	0.1	
	ComADDR2	_____	0		ALM OUT1	_____	NO LAT	
	SHEDENAB	_____	DOSABL		BLOCK	_____	DISABL	
	SHEDTIME	_____	0					
	PARITY	_____	ODD					
	BAUD	_____	2400					
	DUPLEX	_____	HALF					
	WS FLOAT	_____	FP b					
	TX DELAY	_____	1					
	SHEDMODE	_____	LAST					
	SHED SP	_____	TO LSP					
	UNITS	_____	PERCNT					
	CSP RATO	_____	1.0					
	CSP BIAS	_____	0					
	CSP2RATO	_____	1.0					
	CSP2BIAS	_____	0					
	LOOPBACK	_____	DISABL		DISPLAY	DECIMAL	_____	XXXX
						DECIMAL2	_____	XXXX
					TEMPUNIT	_____	NONE	
					PWR FREQ	_____	60 HZ	
					RATIO 2	_____	DISABL	
					LANGUAGE	_____	ENGLIS	
ALARMS	A1S1 VAL	_____	90					
	A1S2 VAL	_____	10					
	A2S1 VAL	_____	95					
	A2S2 VAL	_____	5					
	A1S1TYPE	_____	NONE					
	A1S2TYPE	_____	NONE		MAINTEN	TIME 1	_____	DISABL
	A2S1TYPE	_____	NONE			TIME 2	_____	DISABL
	A2S2TYPE	_____	NONE			TIME 3	_____	DISABL
	A1S1 H L	_____	HIGH			COUNTER1	_____	DISABL
	A1S1 EV	_____	--			COUNTER2	_____	DISABL
	A1S2 H L	_____	LOW			COUNTER3	_____	DISABL
	A1S2 EV	_____	--			PASSWORD	_____	0
	A2S1 H L	_____	HIGH			RESTYPE	_____	NONE
	A2S1 EV	_____	--					
	A2S2 H L	_____	LOW					

## 9. Appendix D – Position Proportional Calibration

### 9.1 Position Proportional Control Output Calibration

#### Introduction

When the UDC3300 controller has a Position Proportional control output, calibrate the controller so that the increase and decrease relays operate properly with respect to the position of the external feedback slidewire.

Three Position Step Control Output Models **with** Motor Position Indication  
(Model Numbers DC330X-EE-XXX-X2, DC330X-AA-XXX-02)

This model must have its output calibrated per the entire procedure to ensure the displayed output (slidewire position) agrees with the final control element position.

Three Position Step Control Output Models **without** Motor Position Indication  
(Model Numbers DC330X-EE-XXX-X0, DC330X-AA-XXX-X0)

This model only requires that the “Motor Time” be entered as shown in the calibration procedure. FULL CALIBRATION IS NOT REQUIRED

#### Procedure

Apply power and allow the controller to warm up 30 minutes before you calibrate. Leave all field wiring connected to the rear terminals.

There are two ways in which to calibrate Position Proportional or 3 Position Step control: AUTO mode or MANUAL mode.

#### *Rules for auto mode vs manual mode*

The Auto-mode selection must be done at least once before the manual mode will operate properly. Failure to use the Auto-mode procedure will prevent the controller from going into automatic control mode.

During the Auto-mode calibration procedure, the values being displayed are used only to indicate if the motor is still traveling. To view the actual calibration value, use the manual mode after the Auto-mode is completed. These values can be changed for purposes of tweaking the calibration.

Make sure LOCKOUT in Tuning Set Up group is set to NONE.

For *Three Position Step Control Output models without Motor Position Indication*, do steps 1 and 2 only.

For *Position Proportional Output and Three Position Step Control Output models with Motor Position Indication*, follow the entire calibration procedure.

**ATTENTION** These prompts *only* appear when position OUT ALG is selected. If motor position for 3PSTEP is desired, first configure unit for “position.” After calibration the unit can be switched to 3PSTEP.

**Table 9-1 Calibration Procedure**

Step	Operation	Press	Action						
1	Enter Calibration Mode	<b>SETUP</b>	until you see <i>Upper Display: CALIB</i> <i>Lower Display: POS PROP</i>						
2	Set Motor Traverse Time	<b>FUNCTION LOOP 1/2</b>	Until you see <i>Upper Display: (A value)</i> <i>Lower Display: MTR TIME</i>  NOTE: This is the time it takes the motor to travel from 0 to 100%.						
3		<b>▲ or ▼</b>	until the proper motor stroke time is reached (see the motor specs or measure the time)  Range of setting = 5 to 1800 Seconds						
4	Select Automatic or Manual Calibration	<b>FUNCTION LOOP 1/2</b>	Until you see <i>Upper Display: DISABL</i> <i>Lower Display: POS PROP</i>  You can calibrate the controller output <b>manually</b> or let the controller calibrate the output <b>automatically</b> .  If the slidewire has never been calibrated, you must use DO AUTO first. In the "Automatic Calibration Mode" (DO AUTO), the controller relays automatically move the motor in the proper direction.  If desired, however, the motor may be manually positioned to 0% and 100% positions. Disconnect the relay wires. Use DO MAN. In the "Manual Calibration Mode" (DO MAN), the motor does not move. Instead, the existing 0% and 100% values may be changed with the <b>▲ or ▼</b> key.						
5		<b>▲ or ▼</b>	to select automatic or manual calibration.  <i>Upper Display: DO AUTO or DO MAN</i> <i>Lower Display: POS PROP</i>						
			<table border="1"> <thead> <tr> <th>If you select...</th> <th>Then...</th> </tr> </thead> <tbody> <tr> <td>DO AUTO</td> <td>go to Step 6</td> </tr> <tr> <td>DO MAN</td> <td>go to Step 8</td> </tr> </tbody> </table>	If you select...	Then...	DO AUTO	go to Step 6	DO MAN	go to Step 8
If you select...	Then...								
DO AUTO	go to Step 6								
DO MAN	go to Step 8								

**ATTENTION** When calibration is terminated, this selection reverts to DISABL.

Step	Operation	Press	Action
6	DO AUTO Set 0% value	<b><u>FUNCTION</u></b> <b>LOOP 1/2</b>	The decrement relay is turned on to move the motor to 0 % position. <i>Upper Display:</i> (Counts of Feedback Slidewire-0 to 3000) <i>Lower Display:</i> ZERO VAL  When the motor stops, the display should stop counting, then go to the next step.
7	DO AUTO Set 100% value	<b><u>FUNCTION</u></b> <b>LOOP 1/2</b>	The increment relay is turned on to move the motor to 100 % position. <i>Upper Display:</i> (Counts of Feedback Slidewire-0 to 3000) <i>Lower Display:</i> SPAN VAL  When the motor stops, the display should stop counting, then go to step 12.
8	DO MAN Set 0% value	<b><u>FUNCTION</u></b> <b>LOOP 1/2</b>	You will see: <i>Upper Display:</i> (The existing zero calibration value in counts) <i>Lower Display:</i> ZERO VAL
9		<b>▲ or ▼</b>	until the desired zero value is reached in the upper display. <i>Upper Display:</i> (The desired zero value) <i>Lower Display:</i> ZERO VAL
10	DO MAN Set 100% value	<b><u>FUNCTION</u></b> <b>LOOP 1/2</b>	The controller will store the 0% value and you will see: <i>Upper Display:</i> (The existing span calibration value in counts) <i>Lower Display:</i> SPAN VAL
11		<b>▲ or ▼</b>	until the desired span value is reached in the upper display. <i>Upper Display:</i> (The desired span value) <i>Lower Display:</i> SPAN VAL  For manual calibration, the motor does not move from its position prior to the start of Position Proportional calibration.
12	Exit the Calibration Mode	<b><u>FUNCTION</u></b> <b>LOOP 1/2</b>  <b>LOWER DISPLAY</b> or <b>SETUP</b>	The controller will store the 100 % value.  To exit the calibration mode.





## 10. Appendix E – Input Ranges

PV Input	Range	
	°F	°C
<b>Thermocouples (Per ITS-90)</b>		
B	0 to 3300	-18 to 1816
E	-454 to 1832	-270 to 1000
E (low)	-200 to 1100	-129 to 593
J	0 to 1600	-18 to 871
J (low)	20 to 770	-7 to 410
K	0 to 2400	-18 to 1316
K (low)	-20 to 1000	-29 to 538
NiNiMoly (NNM68)	32 to 2500	0 to 1371
NiNiMoly (low)	32 to 1260	0 to 682
NiMo-NiCo (NNM90)	32 to 2500	0 to 1371
NiMo-NiCo (low)	32 to 1260	0 to 682
Nicrosil Nisil (NIC)	0 to 2372	-18 to 1300
R	0 to 3100	-18 to 1704
S	0 to 3100	-18 to 1704
T	-300 to 700	-184 to 371
T (low)	-200 to 500	-129 to 260
W5W26	0 to 4200	-18 to 2315
W5W26 (low)	0 to 2240	-18 to 1227
<b>Radiamatic</b>		
Type RH	0 to 3400	-18 to 1871
Type RI	0 to 9999 max.*	-18 to 9999 max.*
<b>RTD IEC Alpha = 0.00385</b>		
100 ohms	-300 to 1200	-184 to 649
100 ohms (low)	-300 to 300	-184 to 149
200 ohms	-300 to 1200	-184 to 649
500 ohms	-300 to 1200	-184 to 649
<b>Linear</b>		
Milliamps	4 to 20 mA 0 to 20 mA	
Millivolts	0 to 10 mV 0 to 50 mV	
Volts	1 to 5 V 0 to 5 V 0 to 10 V	
Carbon	0 to 1250 mV	
Oxygen	-30 to 510 mV	

\*User enters the range manually per RI type and application.





For at reducere risikoen for elektrisk stød og dermed forbundet personskade er det nødvendigt at følge sikkerhedsforskrifterne i følgende dokumentation.



Dette symbol advarer brugeren om en potentiel berøringsfare, såfremt der kan være adgang til den livsfarlige netspænding.



Klemme til beskyttelsesjord. Til tilslutning af ledning til forsyningssystemets jordforbindelse.

- \* Såfremt udstyret anvendes på anden måde end den, producenten har angivet, kan det betyde en forringelse af udstyrets sikkerhed.
- \* Udskift ikke nogen komponent (eller del), som leverandøren ikke specifikt har angivet er udskiftelig.
- \* Al ledningsføring skal være i overensstemmelse med nationale standarder og skal udføres af autoriseret personale med behørig erfaring.
- \* Jordklemmen skal tilsluttes inden andre ledninger (og skal afmonteres sidst).
- \* Det er nødvendigt med en afbryder til strømforsyningen nær udstyret og i umiddelbar nærhed af operatøren.
- \* Tilslutning til strømforsyning kræver en (F) 1/2A, 250 V sikring.

### **UDSTYRETS MÆRKEVÆRDIER**

Netspænding	90/264 V~
Frekvens	50/60 Hz
Nominel effekt	18 VA maksimum

### **MILJØFORHOLD**

Brug ikke instrumentet i nærheden af brandfarlige væsker eller dampe. Anvendelse af elektriske instrumenter i et sådant miljø udgør en sikkerhedsrisiko.

Temperatur	0 til 55° C
Fugtighed	5 til 90% - 40°C
Vibration	Frekvens 0 til 200 Hz
	Acceleration 0,6 g

### **INSTALLATION AF UDSTYR**

Styreenheden skal monteres i en plade eller et panel for at begrænse operatørens adgang til de bageste klemmer.

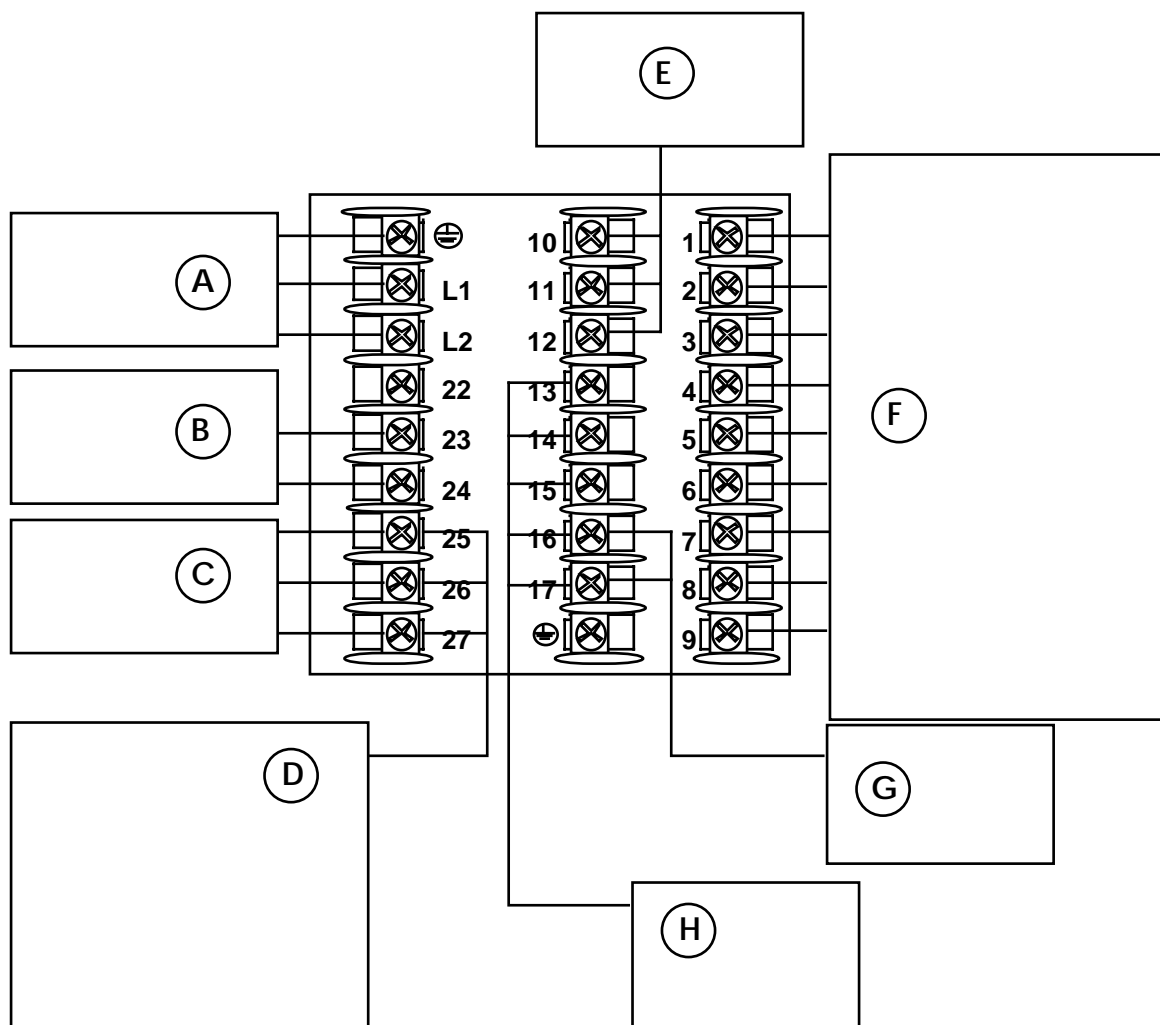

Ⓐ	Terminals for vekselstrøm linienet
Ⓑ	Input # 2 terminals ; 2 HLAI terminals
Ⓒ	Input # 1 terminal
Ⓓ	Strøm til 2 emitter (trådledding) for 4 - 20 mA
Ⓔ	Digitale input terminals
Ⓕ	Terminals for outputs og alarm
Ⓖ	Hjælpe terminals for outputs
Ⓗ	Kommunikations terminals



Noudata kaikkia näitä turvaohjeita vammoja aiheuttavien sähköiskujen välttämiseksi



Tämä merkki varoittaa käyttäjää sähköiskun vaarasta paikassa, missä voi koskettaa vaarallisia jännitteitä.



Suojaavan maadoitusjärjestelmän kytkinpa maadoitetulle käyttövirralle.

- \* Laitteeseen kuuluva suojaus voi heikentyä, jos sitä käytetään valmistajan osoittaman tavan vastaisesti
- \* Älä korvaa mitään komponenttia (tai osaa), ellei jälleenmyyjä ole ilmoittanut sen korvauskelpoisuutta.
- \* Kaikkien johdotusten on oltava paikallisten standardien mukaiset ja kokoneen, valtuutetun asentajan tekemät.
- \* Maadoituspiste on kytkettävä ensimmäisenä ennen muita kytkentöjä (ja irrotettava viimeisenä).
- \* Käyttövirran pääkatkaisijan on oltava laitteen lähellä helposti käyttöhenkilön ulottuvilla.
- \* Käyttövirralle tarvitaan 1/2 A, 250 V sulakkeet.

### **LAITTEEN NIMELLISARVOT**

Käyttöjännite	90/264 V~
Taajuus	50/60 Hz
Teho	18 W maksimi

### **KÄYTTÖOLOSUHTEET**

Älä käytä laitetta tulenarkojen nesteiden tai kaasujen lähistöllä. Jokainen sähkölaite muodostaa vaaratekijän sellaisessa ympäristössä.

Lämpötila	0 - +55°C
Kosteus	5 - 90% / 40°C
Tärinä	Taajuus 0 - 200 Hz
	Iihtyvyys 0,6 g

### **LAITTEEN ASENNUS**

Säätötoiminnot on asennettava paneelille, jotta käyttäjällä olisi rajoitettu pääsy taustakytkentöihin.

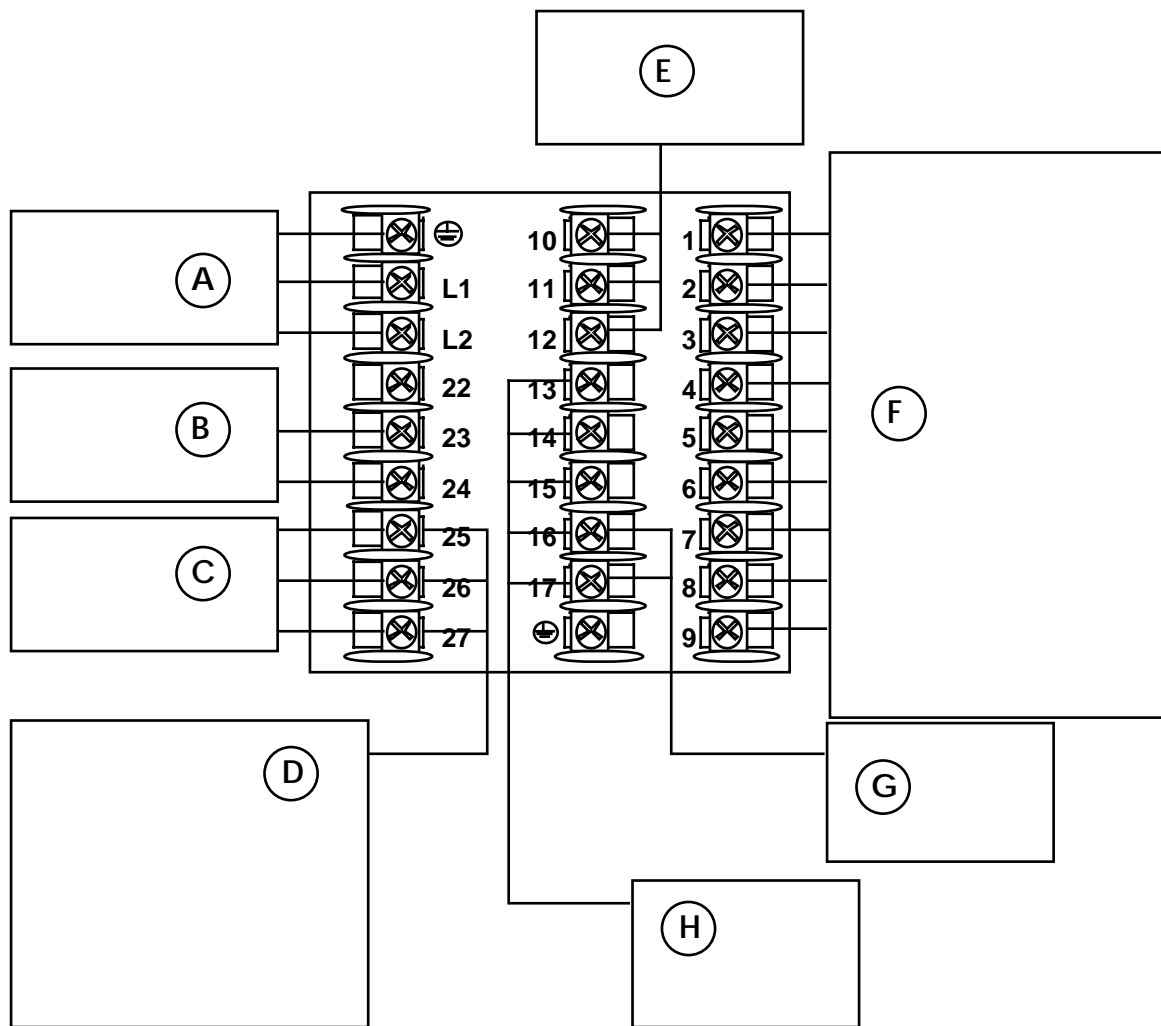

(A)	Linjajännitteiset vaihtovirta liittimet
(B)	N:o 2 sisääntuloliittimet ; 2 HLAI sisääntuloliittimet
(C)	N:o 1 sisääntuloliittimet
(D)	Lähetinteho 4 - 20 mA 2-johtoiselle lähettimelle
(E)	Numeeriset siääntuloliittimet
(F)	Ulostulo- ja hälytysliittimet
(G)	Lisäliittimet ulostulolle
(H)	Tietoliikenneliittimet



Για την αποφυγή του κινδύνου ηλεκτροπληξίας που θα μπορούσε να προκαλέσει προσωπικό τραυματισμό, ακολουθείστε όλες τις υποδείξεις ασφαλείας αυτών των οδηγιών.



Το σύμβολο αυτό προειδοποιεί το χρήστη για πιθανό ηλεκτρικό κίνδυνο σε περίπτωση επαφής με επικίνδυνα μέρη της συσκευής.

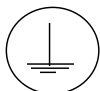

Προστατευτικό τερματικό γείωσης. Παρέχεται για σύνδεση με τον αγωγό προστατευτικής γείωσης του συστήματος τροφοδοσίας.

- Εάν ο εξοπλισμός χρησιμοποιηθεί κατά τρόπο που δεν προβλέπεται από τον κατασκευαστή, διακινδυνεύεται η παρεχόμενη από τον εξοπλισμό προστασία
- Μην αντικαταστήσετε κανένα μέρος (ή εξάρτημα) του οποίου η αντικατάσταση δεν προβλέπεται από τον κατασκευαστή
- Όλες οι ηλεκτρικές εγκαταστάσεις πρέπει να είναι σύμφωνες με τα τοπικά πρότυπα και να πραγματοποιούνται από έμπειρους τεχνικούς.
- Το τερματικό εδάφους πρέπει να συνδέεται πριν από κάθε άλλη σύνδεση (και να αποσυνδέεται τελευταίο).
- Απαιτείται ένας διακόπτης στην κύρια ηλεκτρική εγκατάσταση τροφοδοσίας ηλεκτρικού κοντά στη συσκευή
- Η τροφοδοσία σε ρεύμα απαιτεί μία ασφάλεια (F) 1/2A, 250 V.

### **ΣΥΝΘΗΚΕΣ ΛΕΙΤΟΥΡΓΙΑΣ**

Τροφοδοσία ισχύος 90/264 V~  
Συχνότητα 50/60 Hz  
Ισχύς ρεύματος 18 VA μέγστη

### **ΠΕΡΙΒΑΛΛΟΝΤΙΚΕΣ ΣΥΝΘΗΚΕΣ**

Αποφεύγετε τη λειτουργία του κοντά σε εύφλεκτα υγρά ή αέρια. Η λειτουργία οποιασδήποτε ηλεκτρικής συσκευής σε τέτοιο περιβάλλον εκθέτει σε κίνδυνο για την ασφάλεια.

Θερμοκρασία 0 ως 55 °C  
Υγρασία 5 ως 90 % / 40°C  
Δόνηση Συχνότητα 0 ως 200 Hz  
Επιτάχυνση 0.6 g

### **ΕΓΚΑΤΑΣΤΑΣΗ ΕΞΟΠΛΙΣΜΟΥ**

Η μονάδα αυτή πρέπει να μπει μέσα σε πλαίσιο για να περιορίζεται η πρόσβαση του χρήστη στα πίσω τερματικά.

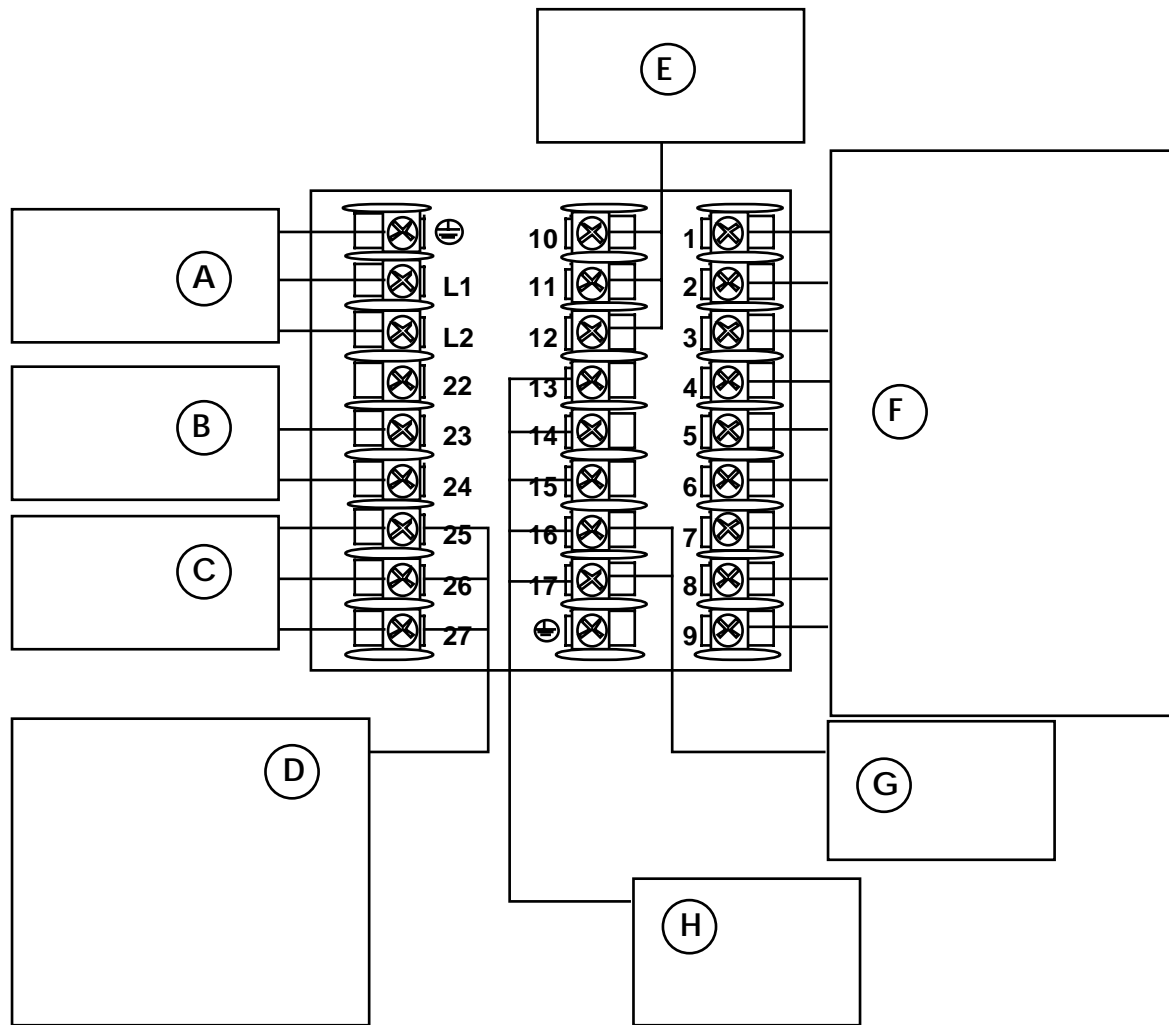

Ⓐ	Ακροδέκτες Τάσης Γραμμής AC
Ⓑ	Ακροδέκτες Εισόδου # 2 ; 2 Ακροδέκτες HLAI
Ⓒ	Ακροδέκτες Εισόδου # 1
Ⓓ	Ισχύς Μεταβιβαστή για 4-20 mA Μεταβιβαστές με 2 σύρματα
Ⓔ	Ακροδέκτες Ψηφιακών Εισαγωγών
Ⓕ	Ακροδέκτες Παροχής και Συναγερμού
Ⓖ	Ακροδέκτες Βοηθητικής Παροχής
Ⓗ	Ακροδέκτες Επικοινωνιών





Teneinde het gevaar voor elektrische schokken die verwondingen kunnen veroorzaken te verminderen, alle instructies van deze documentatie navolgen.



Dit symbool waarschuwt de gebruiker voor een potentieel schokgevaar wanneer toegang bestaat tot onderdelen die onder gevaarlijke spanning staan.



Aansluitklem voor de beveiligingsbearding. Voorzien voor de verbinding van de geleider van het systeem voor beveiligingsbearding.

- \* Wanneer de apparatuur op een manier wordt gebruikt die niet door de fabrikant is aanbevolen kan de beveiliging van de apparatuur haar doeltreffendheid verliezen.
- \* Geen onderdelen vervangen die niet als vervangbaar zijn aangeduid door onze leverancier.
- \* Alle bedrading dient conform te zijn aan lokale normen en te worden aangelegd door bevoegd ervaren personeel.
- \* De bearding dient vóór elke andere bedrading te worden aangesloten (en als laatste te worden ontkoppeld).
- \* Een hoofdnettschakelaar, gemakkelijk bereikbaar door de operateur, is in de nabijheid van deze apparatuur vereist.
- \* Een zekering (F) 1/2A, 250 V, is vereist voor de bedrading van het voedingsnet.

### **TECHNISCHE GEGEVENS**

Voedingsspanning	90/264 V~
Frequentie	50/60 Hz
Vermogen of stroomvermogen	max. 18 VA

### **OMGEVING**

Gebruik het apparaat niet bij brandbare vloeistoffen of dampen. Het gebruik van elektrische apparatuur in zo'n omgeving is gevaarlijk.

Omgevingstemperatuur	0 tot 55°C
Vochtigheidsgraad	5 tot 90% - 40°C
Trilling	Frequentie 0 tot 200 Hz
	Acceleratie 0,6 g

### **INSTALLATIE VAN DE APPARATUUR**

De controle-eenheid dient op een paneel te worden gemonteerd om toegang door de operateur tot de achter aansluitklemmen te verhinderen.

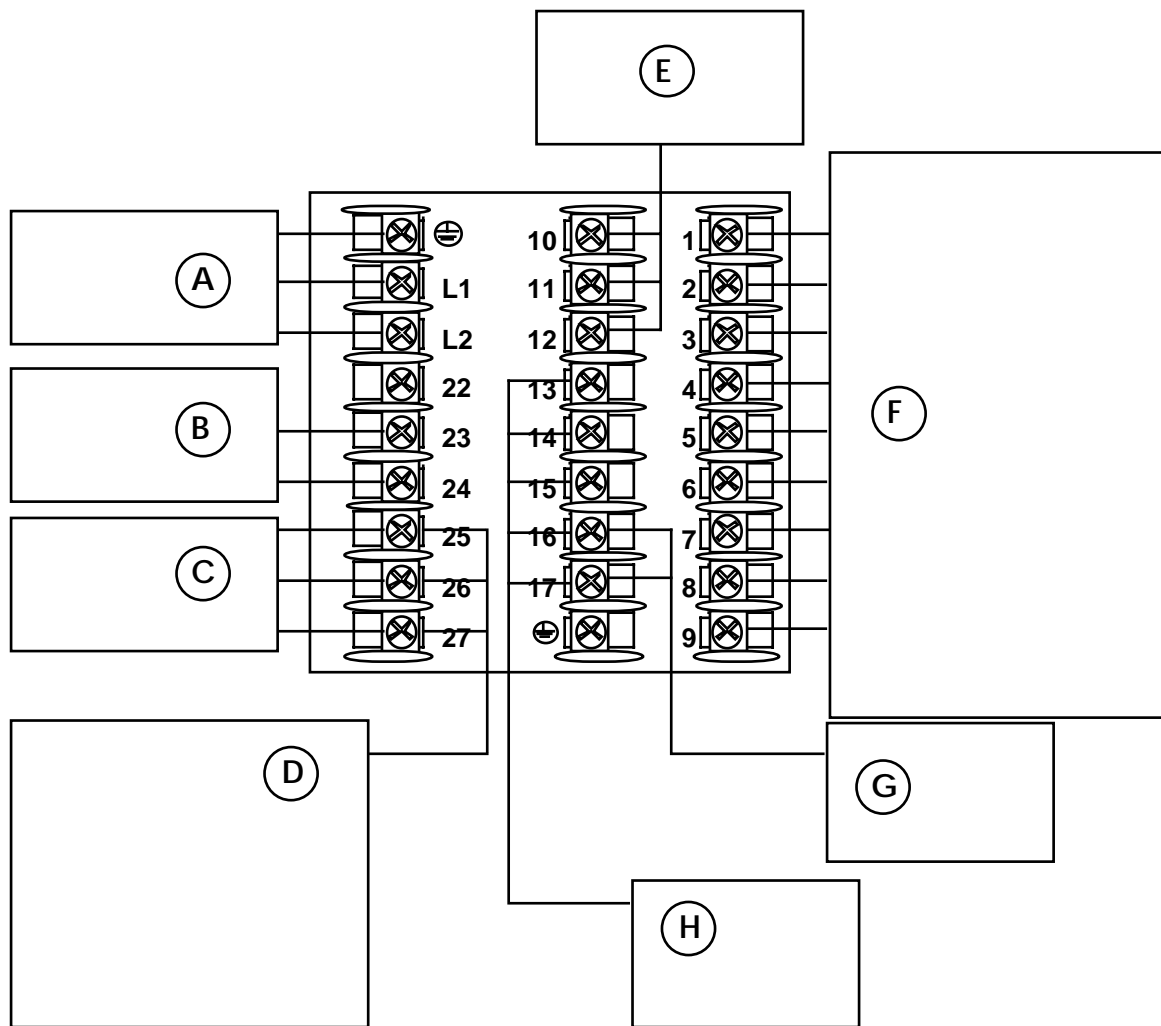

Ⓐ	Wisselstroom lijnspanningsklemmen
Ⓑ	Input nr. 2 klemmen ; 2 HLAI klemmen
Ⓒ	Input nr. 1 klemmen
Ⓓ	Zenderstroom voor 4-20 mA tweedradige zenders
Ⓔ	Digitale inputklemmen
Ⓕ	Klemmen voor output en alarmsignalen
Ⓖ	Auxiliary output klemmen
Ⓗ	Commuunicatieklemmen



Følg alle retningslinjene i dette dokumentet, slik at du reduserer risikoen for elektrisk støt og mulige personskader.



Dette symbolet advarer brukeren om tilgjengelige terminaler med farlige spenninger og en potensiell fare for elektrisk støt.



Jordingsterminal. Kabelen for jording av systemet skal tilknyttes til denne terminalen.

- \* Dersom utstyret benyttes på en måte annerledes enn spesifisert av produsent, kan utstyrets beskyttelsesgrad forringes.
- \* Ingen komponenter eller deler skal skiftes ut dersom de ikke er uttrykkelig spesifisert som utskiftbare av din forhandler.
- \* Det er påkrevet med en hovedstrømsbryter i nærheten av utstyret.
- \* All kabling må utføres i henhold til gjeldende forskrifter og installeres av autoriser og erfaren installatør.
- \* Jord må tilknyttes før all annen kabling (og frakobles sist).
- \* Kabling for strømtilførsel krever (F) 1/2A, 250 V sikring(er).

### **UTSTYRSPESIFIKASJONER**

Strømtilførsel : 90/264 V~

Nettfrekvens : 50/60 Hz

Kraftforbruk : 18VA maksimum

### **OMGIVELSER**

Instrumentet må ikke opereres i nærheten av lettantennelige væsker eller gasser. Bruk av elektriske instrumenter i slike omgivelser utgjør en sikkerhetsrisiko.

Temperatur : 0 til 55°C

Fuktighet : 5 til 90 % - 40°C

Vibrasjon : Frekvens : 0 til 200 Hz

Akselerasjon : 0,6 g

### **INSTALLASJON AV UTSTYRET**

Regulatoren må monteres i panel for å skjermes tilgangen til bakre terminaler.

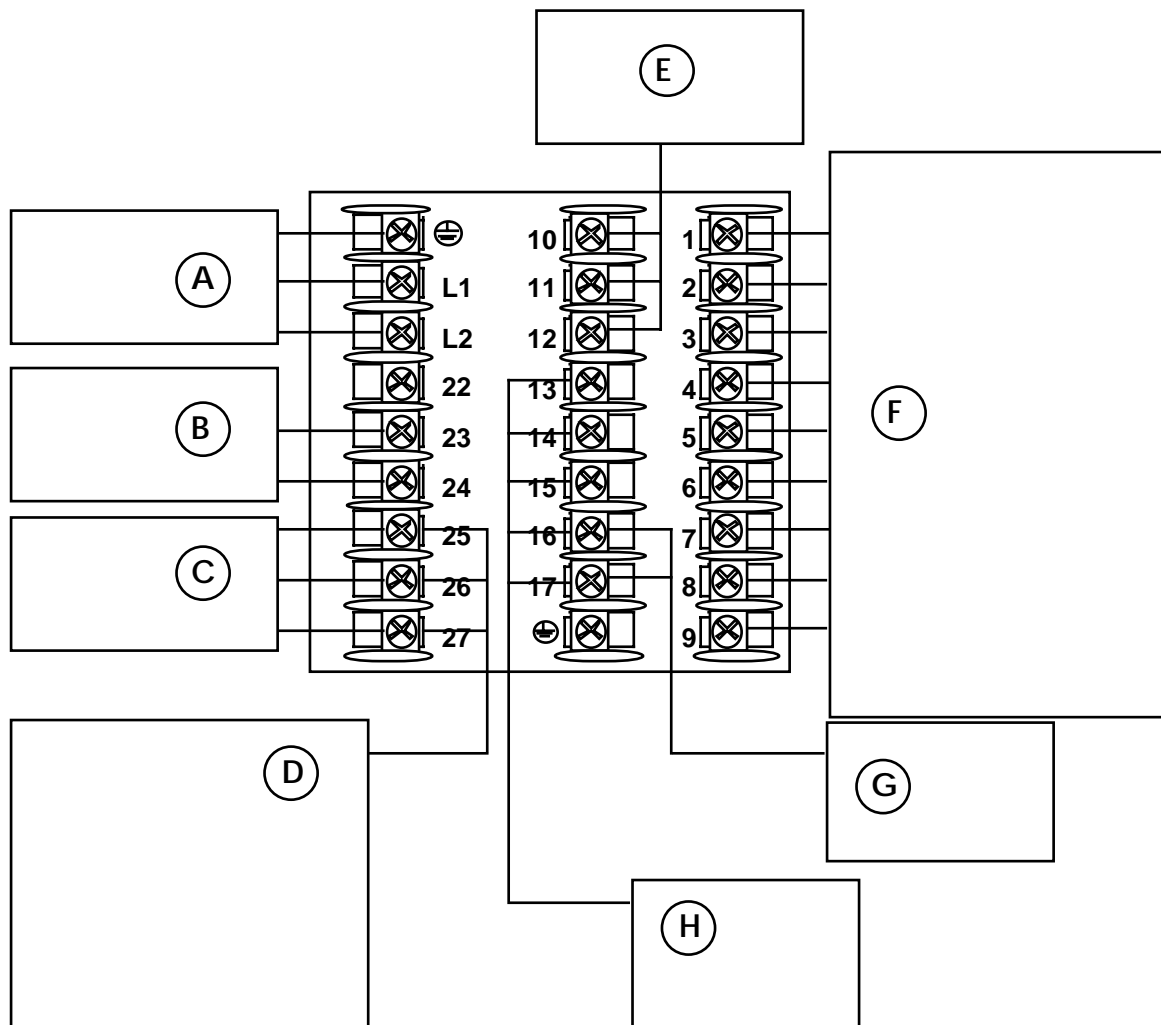

Ⓐ	AC nettspenning terminaler
Ⓑ	Terminaler for inngang #2 2 HLAI terminaler
Ⓒ	Terminaler for inngang #1
Ⓓ	Transmitter strømforsyning for 4-20 mA 2-leder transmittere
Ⓔ	Terminaler for digitale innganger
Ⓕ	Terminaler for utganger og alarmer
Ⓖ	Terminaler for aux utganger
Ⓗ	Terminaler for kommunikasjon

## INSTRUÇÕES DE SEGURANÇA

PO21-6042



Para reduzir o risco de choque eléctrico que pode causar danos físicos, siga todas as instruções de segurança contidas nesta documentação.



Este símbolo avisa o utilizador sobre um eventual perigo de choque quando são acessíveis voltagens sob tensão perigosas.



Terminal de terra de protecção. Fornecido para a conexão do condutor do sistema de alimentação de terra de protecção.

- \* Se o equipamento for utilizado de uma forma não especificada pelo fabricante, a protecção normalmente facultada pode falhar.
- \* Não se deve substituir qualquer componente (ou peça) que não seja explicitamente especificado como substituível pelo nosso revendedor.
- \* Todos os fios devem estar em conformidade com as normas locais e instalados por profissionais autorizados.
- \* O terminal de terra deve ser ligado antes de qualquer outro fio (e desligado em último lugar).
- \* É necessário um interruptor na alimentação principal perto do equipamento ao alcance do operador.
- \* Os fios de alimentação principal necessitam de fusíveis (F) 1/2 A; 250 V.

### ESPECIFICAÇÕES DO EQUIPAMENTO

Voltagem	90/264 V~
Frequência	50/60 Hz
Potência	18 VA máximo

### CONDIÇÕES DO MEIO AMBIENTE

Não colocar o equipamento em funcionamento na presença de líquidos ou vapores inflamáveis. A utilização de qualquer equipamento eléctrico num ambiente deste tipo comporta riscos de segurança.

Temperatura	0 a 55°C	
Humidade	5 a 90% - 40°C	
Vibração	Frequência	0 a 200 Hz
	Acceleração	0,6 g

### INSTALAÇÃO DO EQUIPAMENTO

O controlador deve ser montado num painel para limitar o acesso do operador aos terminais traseiros.

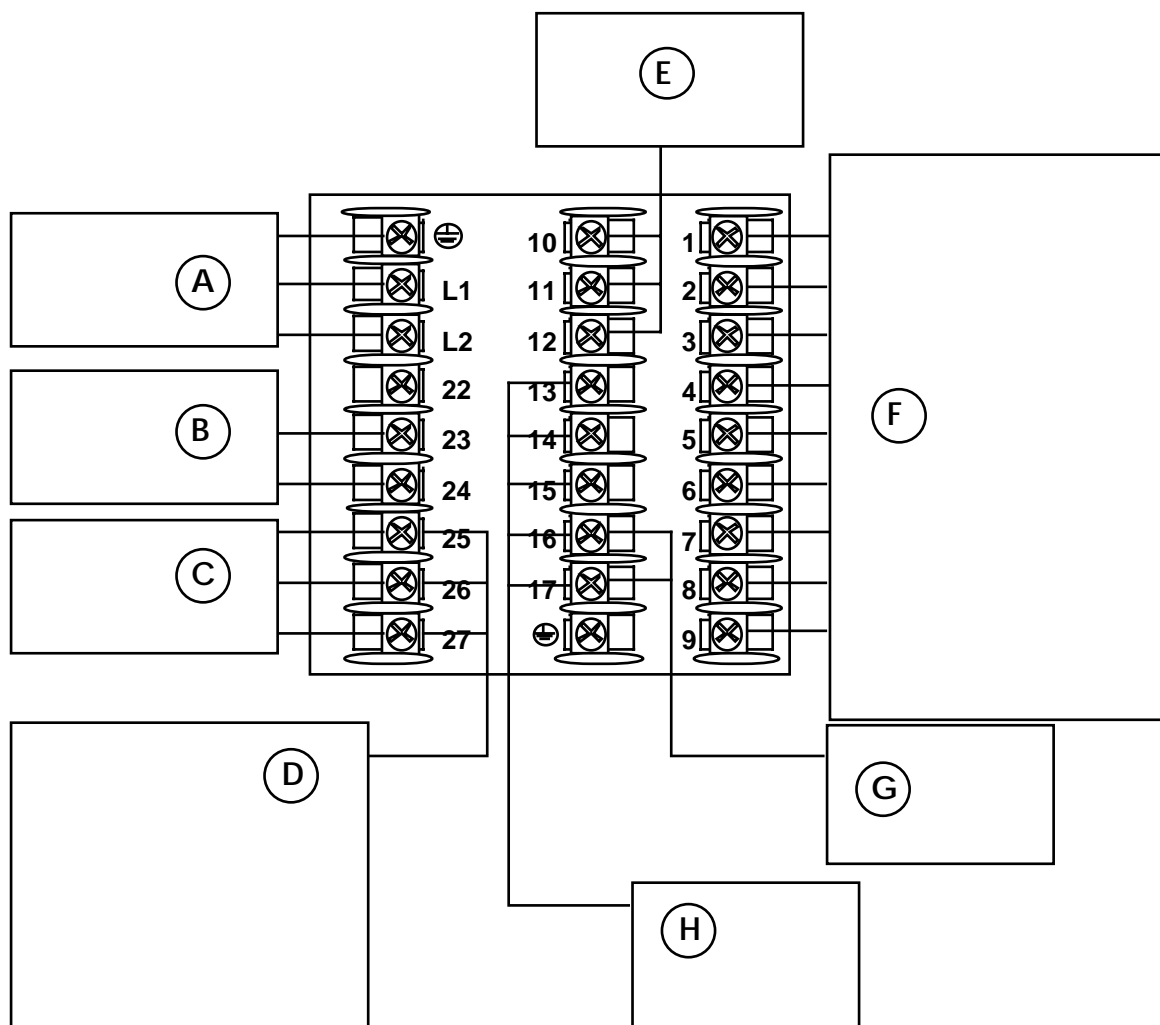

(A)	Terminais tensão linha corrente alternada
(B)	Terminais de entrada # 2 ; 2 terminais HLAI
(C)	Terminais de entrada # 1
(D)	Transmissor potência para 4-20 mA - Transmissores por fio
(E)	Terminais de entradas digitais
(F)	Saídas e terminais de alarmes
(G)	Terminais auxiliares de saída
(H)	Terminais de comunicações



Följ noga handbokens samtliga säkerhetsföreskrifter för att undvika elstötar och åtföljande personsador.



Denna symbol varnar användaren för risk för elchock vid tillfällig åtkomst av spänningsförande del.



Skyddat jorduttag. Avsedd för anslutning av skyddande jordnätets ledare.

- \* Om utrustningen används på ett sätt som ej förutsetts av tillverkaren kan säkerhetsskyddet visa sig vara otillräckligt.
- \* Byt inte ut någon komponent (eller del) om denna inte klart angivits som utbytbar av tillverkaren.
- \* All kabeldragning skall följa de lokala föreskrifterna och utföras av en kompetent och erfaren fackman.
- \* Jorduttaget måste anslutas innan all annan kabeldragning (och kopplas från sist).
- \* En nätströmbrytare skall finnas i närheten av utrustningen, inom bekvämt räckhåll för operatören.
- \* Huvudnätets kabeldragning kräver (F) 1/2 A, 250 V säkring(ar).

### **UTRUSTNINGENS MÄRKDATA**

Nätspänning	90/264 V~
Frekvens	50/60 Hz
Effekt eller märkström	18 VA maximum

### **MILJÖVILLKOR**

Använd inte utrustningen i närheten av lättantändliga vätskor eller ångor. Drift av elektriska instrument i en sådan omgivning är att leka med säkerheten.

Temperatur	0 till 55°C
Fuktighet	5 till 90 % - 40°C
Vibration	Frekvens 0 till 200 Hz Acceleration 0,6 gram

### **INSTALLERING AV UTRUSTNING**

Kontrollern skall monteras i en panel för att minska operatörens åtkomst till de bakre terminalerna.

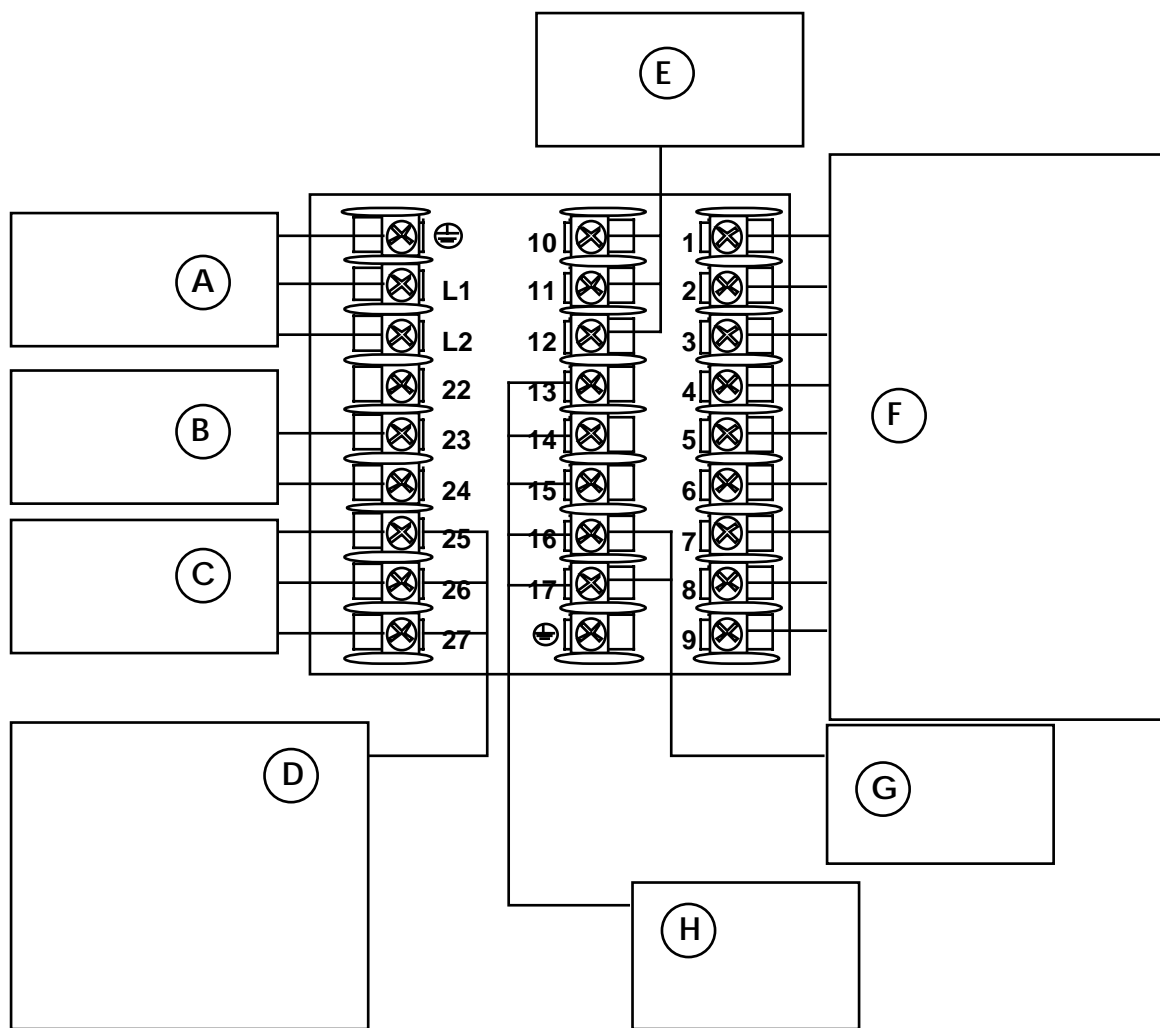

Ⓐ	AC Kabelspänningsterminaler
Ⓑ	Input *2 Terminaler ; 2 HLAI Terminaler
Ⓒ	Input*1 Terminaler
Ⓓ	Kraftöverföring för 4-20 mA-Överföringskabel
Ⓔ	Digitalinputsterminaler
Ⓕ	Ouput och Alarmterminaler
Ⓖ	Extra outputsterminaler
Ⓗ	Kommunikationsterminaler





