

MITSUBISHI

GOT1000 Series CF Card /Memory Card Adaptor

User's Manual

GT05-MEM-16MC
GT05-MEM-32MC
GT05-MEM-64MC
GT05-MEM-128MC
GT05-MEM-256MC
GT05-MEM-512MC
GT05-MEM-1GC
GT05-MEM-2GC
GT05-MEM-ADPC

Thank you for purchasing the GOT1000 Series.

Prior to use, please read both this manual and detailed manual thoroughly to fully understand the product.

MODEL	GT05-MEM-U
MODEL CODE	1D7M08
IB(NA)-0800302-D(0810)MEE	

GRAPHIC OPERATION TERMINAL
GOT1000

SAFETY PRECAUTIONS

(Always read these precautions before using this equipment.)

Before using this product, please read this manual and the relevant manuals introduced in this manual carefully and pay full attention to safety to handle the product correctly.

The precautions given in this manual are concerned with this product. In this manual, the safety precautions are ranked as "DANGER" and "CAUTION".

DANGER Indicates that incorrect handling may cause hazardous conditions, resulting in death or severe injury.

CAUTION Indicates that incorrect handling may cause hazardous conditions, resulting in medium or slight personal injury or physical damage.

Note that the CAUTION level may lead to a serious accident according to the circumstances. Always follow the precautions of both levels because they are important to personal safety. Please save this manual to make it accessible when required and always forward it to the end user.

[INSTALLING PRECAUTIONS]

CAUTION

- Before installing/removing the CF card into/from the GOT, be sure to set the CF card access switch to OFF to turn off the CF card access LED. Failure to do so may cause data corruption or malfunction.
- When ejecting the CF card, support it by hand since it may pop out. Failure to do so may cause a fall of the CF card leading to failure or damage of the card.
- Use the CF card and memory card adaptor in the environment designated by the general specifications described in GT16 User's Manual, GT15 User's Manual, GT11 User's Manual or Handy GOT User's Manual. Failure to do so may cause an electric shock, fire, malfunction, product damage or deterioration.

[STARTUP AND MAINTENANCE PRECAUTIONS]

CAUTION

- Never disassemble or modify the CF card and memory card adaptor. To do so may cause a failure, malfunction, injury or fire.
- Before touching the CF card or memory card adaptor, be sure to touch grounded metal or similar object to discharge the static electricity from human body. Failure to do so may cause a malfunction or failure of the unit.

[DISPOSAL PRECAUTIONS]

CAUTION

- Dispose of this product as industrial waste.

[TRANSPORTATION PRECAUTIONS]

CAUTION

- Make sure to transport the GOT main unit and/or relevant unit(s) in the manner they will not be exposed to the impact exceeding the impact resistance described in the general specifications of GT16 User's Manual, GT15 User's Manual, GT11 User's Manual or Handy GOT User's Manual, as they are precision devices. Failure to do so may cause the unit to fail. Check if the unit operates correctly after transportation.

Manuals

The following shows manuals relevant to this product.

Detailed Manual

Manual name	Manual Number (Model code)
GT16 User's Manual (Sold separately)	SH-080778ENG (1D7M88)
GT15 User's Manual (Sold separately)	SH-080528ENG (1D7M23)
GT11 User's Manual (Sold separately)	JY997D17501 (09R815)
Handy GOT User's Manual (Sold separately)	JY997D20101 (09R817)

Relevant Manuals

For relevant manuals, refer to the PDF manuals stored in the GT Designer2 CD-ROM.

© 2004 MITSUBISHI ELECTRIC CORPORATION

Compliance with the EMC and Low Voltage

Directives

When incorporating the Mitsubishi GOT into other machinery or equipment and keeping compliance with the EMC and low voltage directives, refer to GT15 User's Manual, GT11 User's Manual Handy GOT User's Manual. The CE logo is printed on the rating plate of the GOT, indicating compliance with the EMC and low voltage directives.

Packing List

The following items are included.

Model	Product	Quantity
GT05-MEM-16MC, GT05-MEM-32MC, GT05-MEM-64MC, GT05-MEM-128MC, GT05-MEM-256MC, GT05-MEM-512MC, GT05-MEM-1GC, GT05-MEM-2GC	CF card	1
GT05-MEM-ADPC	Memory card adaptor	1

1. Overview

This User's Manual describes the GOT1000 series CF card and memory card adaptor (hereafter abbreviated to the CF card and memory card adaptor). By installing the CF card, OS and project data can be transferred and functions can be increased. Refer to GT16 User's Manual, GT15 User's Manual, GT11 User's Manual or Handy GOT User's Manual for the applicable GOT. Refer to GT Designer2 Version □ Basic Operation/Data Transfer Manual or Handy GOT User's Manual for transfer of the OS and project data. Refer to GT Designer2 Version □ Screen Design Manual for the increased functions. The memory card adaptor converts the CF card into a memory card (TYPE II).

2. Specifications

The performance specifications of the CF card and memory card adaptor are indicated below. The general specifications of the CF card and memory card adaptor are the same as those of the GOT. Refer to GT16 User's Manual, GT15 User's Manual, GT11 User's Manual or Handy GOT User's Manual for the general specifications of the GOT.

Item	GT05-MEM-16MC	GT05-MEM-32MC	GT05-MEM-64MC	GT05-MEM-128MC	GT05-MEM-256MC	GT05-MEM-512MC
Memory capacity	16M bytes	32M bytes	64M bytes	128M bytes	256M bytes	512M bytes
Number of write times	300,000 times					
Weight	0.01kg (0.03lb)					

Item	GT05-MEM-1GC	GT05-MEM-2GC	GT05-MEM-ADPC
Memory capacity	1G bytes	2G bytes	-
Number of write times	300,000 times		
Weight	0.01kg (0.03lb)	0.02kg (0.05lb)	-

3. Part Names and External Dimensions

(1) CF card

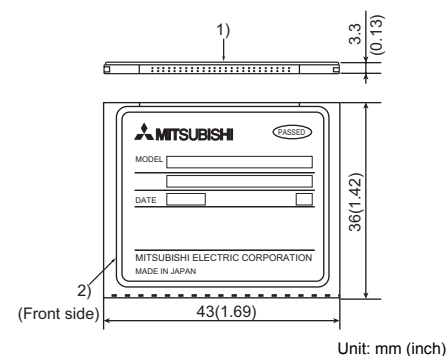

No.	Name	Description
1)	Connector	For connecting the CF card interface of the GOT
2)	Rating plate	-

(2) Memory card adaptor

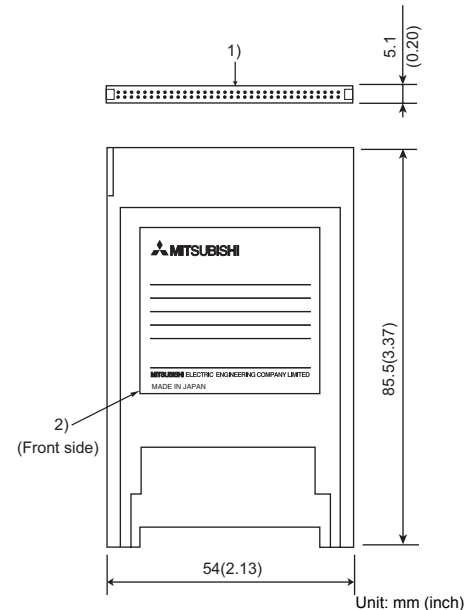

No.	Name	Description
1)	Connector	For connecting the memory card interface of the personal computer
2)	Rating plate	-

4. Installing and Removing Procedures

The method for mounting and removing the CF card is explained using the GT 15 as an example. Refer to the GT16 User's Manual, GT11 User's Manual, Handy GOT User's Manual for the CF card mounting and removal methods for the GT16, GT11 and Handy GOT.

4.1 Installing the CF Card

(1) Turn the CF card access switch of the GOT off.

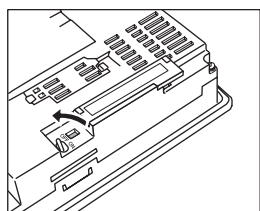

(2) Open the cover of the CF card interface. Insert and install the CF card into the CF card interface with its front side outside. *1

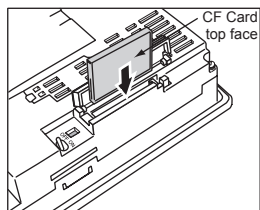

*1 CF card eject button

For the following GOTs, after installing the CF card, turn the CF card eject button to 90 degree while being pulled.

- GT1585-S, GT1575-S: Hardware version B (April, 2005) or earlier
- GT1575-V, GT1565-V: Hardware version D (April, 2005) or earlier

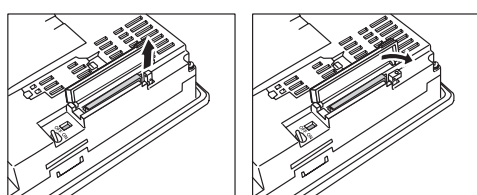

(3) Close the cover of the CF card interface. Set the CF card access switch to ON.

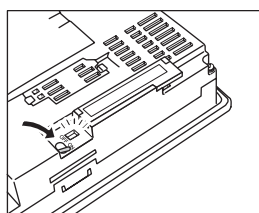

4.2 Removing the CF Card

(1) Turn the CF card access switch of the GOT off, and make sure that the CF card access LED has been turned off. (When the CF card access LED turns off, the CF card can be removed even during the GOT power on.)

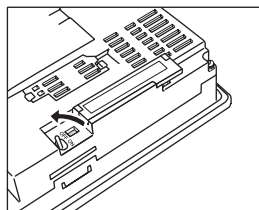

(2) Push the CF card eject button of the GOT. *2 (The CF card eject button is pulled out after pushing at once.)

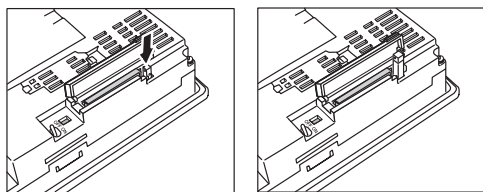

*2 CF card eject button

For the following GOTs, after opening the cover of the CF card interface, raise the CF card eject button.

- GT1585-S, GT1575-S: Hardware version B (April, 2005) or earlier
- GT1575-V, GT1565-V: Hardware version D (April, 2005) or earlier

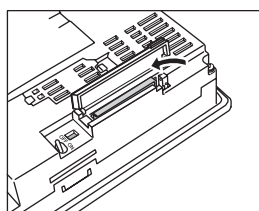

(3) Push the CF card eject button of the GOT to lift the CF card and remove it.

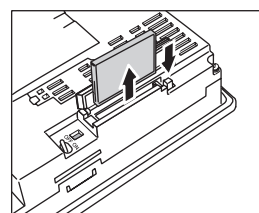

4.3 Precautions for Installing and Removing the CF Card

- While the CF card access LED is on, do not install/remove the CF card or power off the GOT. To do so may cause data corruption or malfunction.
- When ejecting the CF card, support it by hand since it may pop out. Failure to do so may cause a fall of the CF card leading to failure or damage of the card.

Warranty

Mitsubishi will not be held liable for damage caused by factors found not to be the cause of Mitsubishi; machine damage or lost profits caused by faults in the Mitsubishi products; damage, secondary damage, accident compensation caused by special factors unpredictable by Mitsubishi; damages to products other than Mitsubishi products; and to other duties.

For safe use

- This product has been manufactured as a general-purpose part for general industries, and has not been designed or manufactured to be incorporated in a device or system used in purposes related to human life.
- Before using the product for special purposes such as nuclear power, electric power, aerospace, medicine or passenger movement vehicles, consult with Mitsubishi.
- This product has been manufactured under strict quality control. However, when installing the product where major accidents or losses could occur if the product fails, install appropriate backup or failsafe functions in the system.

Country/Region Sales office/Tel

U.S.A	Mitsubishi Electric Automation Inc. 500 Corporate Woods Parkway Vernon Hills, IL 60061, U.S.A. Tel : +1-847-478-2100
Brazil	MELCOO-TEC Rep. Com. Assessoria Tecnica Ltda. Rua Correia Dias, 184, Edificio Paraiso Trade Center-8 andar Paraiso, Sao Paulo, SP Brazil Tel : +55-11-5908-8331
Germany	Mitsubishi Electric Europe B.V. German Branch Gothaer Strasse 8 D-40880 Ratingen, GERMANY Tel : +49-2102-486-0
U.K	Mitsubishi Electric Europe B.V. UK Branch Travellers Lane, Hatfield, Hertfordshire., AL10 8XB, U.K. Tel : +44-1707-276100
Italy	Mitsubishi Electric Europe B.V. Italian Branch Centro Dir. Colleoni, Pal. Perso-Ingr.2 Via Paracelso 12, I-20041 Agrate Brianza., Milano, Italy Tel : +39-039-60531
Spain	Mitsubishi Electric Europe B.V. Spanish Branch Carretera de Rubi 76-80 E-08190 Sant Cugat del Valles, Barcelona, Spain Tel : +34-93-565-3131
France	Mitsubishi Electric Europe B.V. French Branch 25, Boulevard des Bouvets, F-92741 Nanterre Cedex, France TEL: +33-1-5568-5568
South Africa	Circuit Breaker Industries Ltd. Private Bag 2016, ZA-1600 Isando, South Africa Tel : +27-11-928-2000
Hong Kong	Mitsubishi Electric Automation (Hong Kong) Ltd. 10th Floor, Manulife Tower, 168 Electric Road, North Point, Hong Kong Tel : +852-2887-8870
China	Mitsubishi Electric Automation (Shanghai) Ltd. 4/F Zhi Fu Plaza, No.80 Xin Chang Road, Shanghai 200003, China Tel : +86-21-6120-0808
Taiwan	Setsumo Enterprise Co., Ltd. 6F No.105 Wu-Kung 3rd Rd, Wu-Ku Hsiang, Taipei Hsine, Taiwan Tel : +886-2-2299-2499
Korea	Mitsubishi Electric Automation Korea Co., Ltd. 1480-6, Gayang-dong, Gangseo-ku Seoul 157-200, Korea Tel : +82-2-3660-9552
Singapore	Mitsubishi Electric Asia Pte. Ltd. 307 Alexandra Road #05-01/02, Mitsubishi Electric Building, Singapore 159943 Tel : +65-6470-2460
Thailand	Mitsubishi Electric Automation (Thailand) Co., Ltd. Bang-Chan Industrial Estate No.111 Moo 4, Senthai Rd, T.Kamnyao, A.Kamnyao, Bangkok 10230 Thailand Tel : +66-2-517-1328
Indonesia	P.T. Autoteknindo Sumber Makmur Muara Karang Selatan, Block A/Ulara No.1 Kav. No.11 Kawasan Industri Pergudangan Jakarta - Utara 14440, P.O.Box 5045 Jakarta, 11050 Indonesia Tel : +62-21-6630833
India	Messung Systems Pvt. Ltd. Electronic Sadan NO:III Unit No15, M.I.D.C Bhosari, Pune-411025, India Tel : +91-20-2712-3130
Australia	Mitsubishi Electric Australia Pty. Ltd. 348 Victoria Road, Rydalmere, N.S.W 2116, Australia Tel : +61-2-9684-7777

MITSUBISHI ELECTRIC CORPORATION
HEAD OFFICE: TOKYO BUILDING 2-7-3 MARUNOUCHI, CHIYODA-KU, TOKYO 100-8310, JAPAN
NAGOYA WORKS: 1-14, YADA-MINAMI 5-CHOME, HIGASHI-KU, NAGOYA, JAPAN

When exported from Japan, this manual does not require application to the Ministry of Economy, Trade and Industry for service transaction permission.

Specifications subject to change without notice. Printed in Japan.