

KH406 MAXI LIFT



(SHOWN WITH OPTIONAL WEIGHT SCALE)

OPERATING, MAINTENANCE & CLEANING MANUAL



KEIM-045

INDEX

	PAGE
SPECIFICATIONS	2
SAFETY PRECAUTIONS	3
OPERATING INSTRUCTIONS	3
MAINTENANCE INSTRUCTIONS	5
CLEANING INSTRUCTIONS	7

SPECIFICATIONS

<u>DIMENSIONS:</u>	Length	1445mm
	Width	770mm
	Height	1460mm
	Effective lift range	600mm – 1880mm
	Leg gating (inside)	590mm – 1090mm
	Lift reach	1140mm
	Under base clearance	60mm
	Base height	220mm
	Leg height from floor	130mm
	Turning radius	1340mm

LIFT SPEED: Slow - 30mm per second

LIFT DRY WEIGHT: 70 Kg (with battery)

LIFT CAPACITY: Max load - 300kg

CASTORS: Ø150 Total lock rear polyurethane castor
Ø75 Swivel front polyurethane castor
Note: *Smaller castors available on request.*

FINISH: Epoxy powder coated
Polyurethane legs and yoke
PVC cover

ELECTRICAL ITEMS: Tested by Linak Australia to standards: -
AS 3108-1990 and AS 3200.1-1990

SAFETY PRECAUTIONS.

1. Always use the correct slings on the hoist.
2. The **MAXIMUM** safe working load is **300 Kg.**
3. **EMERGENCY STOP**
This is the big RED switch, located on the front of the controller. If there is a need to use this, simply depress the switch and it will automatically lock the position and cut all power to the electrical system.
To disengage the emergency stop switch after it has been depressed, turn the switch in a clockwise direction and the switch should return to its original position.
5. **EMERGENCY LOWERING/RAISING:**
The emergency lowering/raising buttons can be used to lower/raise the hoist if there is a electrical or handset failure. The switches are located on the controller under the big red emergency stop switch. Simply press, using a ball point pen or similar object.
6. For safety precautions only properly trained personal should use the hoist.

OPERATING INSTRUCTIONS

OPERATING INSTRUCTIONS:

1. **INSTALLATION OF BATTERY PACK.**

Before the MAXI LIFT can be operated the battery pack will need to be placed on charge (See 2.1.2 - For Charging Battery) When the battery pack is fully charged, remove the battery from the charger and place on the hoist. Simply locate the battery on the mounting bracket and clip the release lever into the secure position. The Maxi Lift is now ready for use.



Fig 1

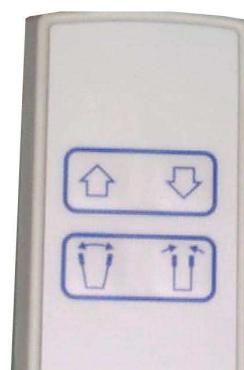

Fig 2

2. **HANDSET:**

2.1 RAISE/LOWER:

The MAXI LIFT operates via a touch pad handset. The top two switches on the handset are for raising and lowering. To raise or lower the hoist, simply press the required switch on the pad. (Fig 4)

2.2 LEG GATING:

To OPEN or CLOSE the “Gate” on the legs, simply press the lower two switches on the handset. (Fig 2 shows the lower sets of switches are for the leg “gate”). Open on the left, close on the right.

3 YOKE- SLING MOUNTING POINT. (Fig 3)

Refer to the fitting instructions supplied with your chosen sling.



Fig 3

4 BATTERY CARE AND CHARGING:

4.1 CHARGING:

Before the KH 405 F can be operated the battery pack will need to be charged. Please follow the instructions below.

4.2 Plug the charger unit (Fig 4) into the 240 Volt supply outlet. The unit is now ready to accept a battery that requires charging, a GREEN L.E.D. (ON) will be displayed.

4.3 To charge the battery, simply locate the battery on the mount bracket and clip into position. (The GREEN and ORANGE L.E.D. on the front of the charger will be displayed). The battery is fully charged when the ORANGE L.E.D. is OFF and only the GREEN L.E.D. is displayed.

4.4 If a two battery system is going to be used, replace the first battery once charged, with the second battery. Charge using the same procedure as above.

NOTE:

A battery pack may remain on charge indefinitely without any detrimental effects to the battery or charging unit.



Fig 4 Charger unit shown without battery attached.

5. BATTERY CARE:

The KH 406 uses fully sealed lead acid batteries. They are designed to be recharged on a regular basis. To care for your batteries and obtain the maximum life **DO NOT** allow the batteries to run totally flat before recharging.

The controller is fitted with an **audio low battery warning alarm**. When this warning alarm sounds complete the lift process, then change the battery and recharge. Kerry Equipment recommends that a 2-battery system be used, this allows one battery to always be on charge while the other is in use, hence the hoist may never be out of service with a flat battery.

MAINTENANCE INSTRUCTIONS

LUBRICATION

The KH 406 MAXI LIFT requires periodical lubrication. These points are:

1. CASTORS

It is always best practice to remove all hair and lint from the castors as soon as possible, always allowing free movement of all the wheels.

The castors need to be lubricated monthly (Use TAC-2 only). This involves: -

- 1.1 The Castor head bearing will need lubricating. Simply spray TAC-2 up into the bearing while rotating the castor (Fig 5).
- 1.2 The wheel also requires lubricating every couple of months. To do this the wheel must be unbolted and removed from the castor frame. TAC-2 can then be sprayed into the hub centre to lubricate the internal bearings (Fig 6).



Fig 5



Fig 6

2. BASE PIVOT POINTS

All pivot points will need to be lubricated with TAC-2 or similar lubricant. Simply spray for 2 seconds on each side of the recommended points monthly.

The hoist has to be turned onto its side for access to the following lubrication points. (To do this 2 people are required.)

Follow the instruction below:

- 2.1 Both people are to stand on one side of the hoist. One near the push handle, the other by the side of the hoist.
- 2.2 The person near the push handle locks the total lock castors.

- 2.3 In conjunction with one another pull the hoist towards the side, lowering the hoist onto its side on the floor.
- 2.4 The hoist can lie on its side without damage to the plastic cover, but care must be taken when lowering/raising.
You now have access to all the lubrication points. ie: pivot points, leg lever and leg pivot. Simply spray TAC-2 on all the pivot points for 2 seconds.

Leg Actuator Pivots (Fig 7)
 Leg Pivots (Fig 7)
 Tie Rod Pivot Points (Fig 7)

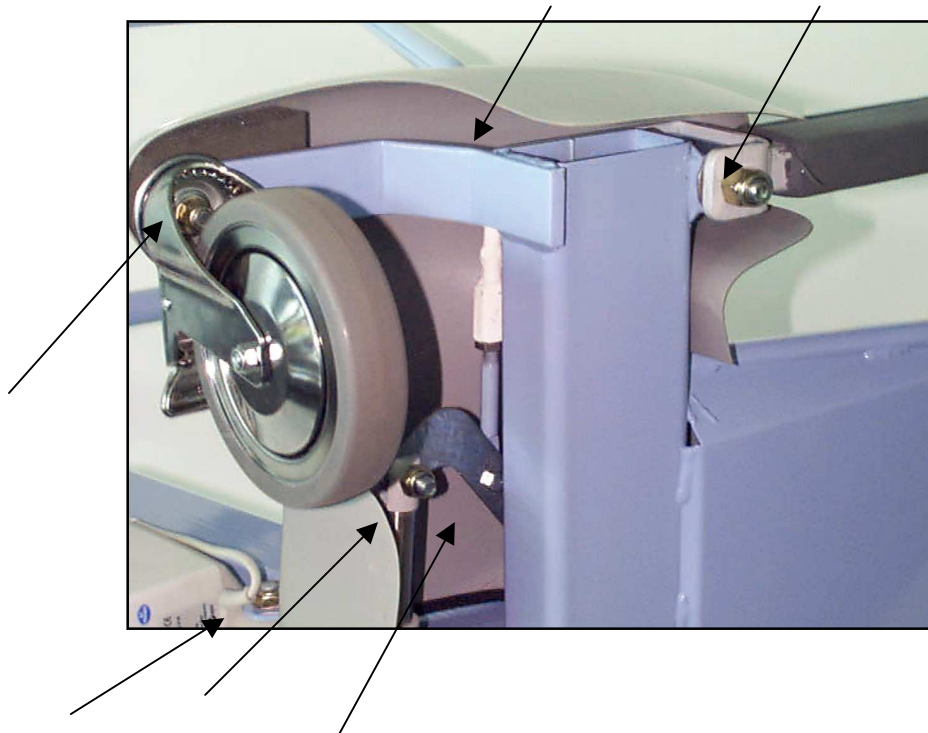

Fig 7

3. ARM AND ACTUATOR PIVOT POINTS

The arm pivot points will need to be lubricated with TAC-2 or similar lubricant. Simply spray for 2 seconds on each side of the recommended points monthly.

- 3.1 Arm Pivot (Fig 8)
 Actuator Pivots (Fig 8)

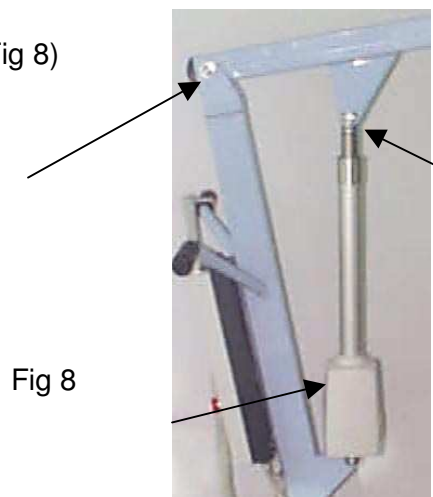

Fig 8

NOTE: TAC-2 is a CRC product and is available from most automotive outlets or from Kerry Equipment

GENERAL CLEANING

1. The KH 406 MAXI LIFT can be cleaned with a low strength detergent, warm water and a soft textured cloth. This includes All stainless steel, Epoxy powder coated framework.

2. SLING CARE

Protect from direct sunlight.
Repair any cuts or fraying immediately.
Slings are machine washable.

3. CAUTION

Do not immerse any parts in water.
Do not allow water/cleaning liquid to enter the battery or controller.
Clean up spills immediately.



A  Hills Company

Kerry Equipment (Aust) Pty Ltd

ABN 71 082 784 147

4 Halley Road
Balcatta, Perth
Australia 6021

Telephone +61 8 9240 2944
Facsimile +61 8 9240 1489
email@kerryequipment.com.au

www.kerryequipment.com.au

Manufactures of
Hospital & Nursing Home Equipment