



Series
R_D

80%
ENERGY SAVING

INSTRUCTION MANUAL

RD SERIES
Digital Electric Water Heater
Wall-hung Unvented

5 years
Guarantee
Electric and
electronic components



**HIGH
QUALITY
component**
comhouse

OPTIMIZER[®]
energy plus





WELCOME

Dear Customer,

Thank you for choosing the RD Series electric water heater, with an exclusive electronic temperature programmer and made with the highest quality materials.

The RD Series water heaters have exceeded the most stringent quality controls in order to comply with the most rigorous requirements for both safety and energy efficiency.

Thanks to its exclusive ROINTE Optimizer Energy Plus technology, the electric water heater achieves the maximum energy saving.

Before using the electric water heater we recommend you read this manual carefully in order to obtain proper operating information.

IMPORTANT

THIS MANUAL SHOULD BE LEFT WITH THE UNIT AFTER INSTALLATION



TABLE OF CONTENTS

1. Introduction	4
2. Component Check List	4
3. General requirements	5
4. Plumbing Installation	6
5. Electrical installation	10
6. Filling and commissioning	11
7. Servicing and maintenance	11
8. Fault finding	12
9. User instructions	13
10. Warranty	16
11. Installation, Commissioning and Service Record	17



1. INTRODUCTION

The "RD Series" is a high quality unvented enamelled steel domestic hot water cylinder suitable for domestic hot water systems where the cold mains water supply is between 3 bar and 9 bar. Reduced performance is available at lower pressures but the units are not suitable for pressures lower than 1.5 bar and flow rate of 20 litres per minute.

Rointe offers the possibility to acquire all the necessary safety equipment to comply with legislation governing the installation of such systems.

TECHNICAL SPECIFICATIONS			
MODEL NUMBER	RDI50	RDI75	RDI100
Storage capacity (litres)	50	75	100
Power (w)	1600	2000	2000
Depth (mm)	404	404	404
Width (mm)	404	404	404
Overall height incl t&p valve	760	1005	1165
Height excl t&p valve	680	925	1085
Weight when full (kg)	68	100	132
Cold feed/hot draw off connections (mm)	15	15	15
Maximum water supply pressure (bar)	9	9	9
System operating pressure (pre-set) (bar)	3	3	3
Expansion vessel charge pressure (bar)	3	3	3
Expansion relief valve set pressure (bar)	7	7	7
Temperature and pressure relief valve settings:			
Lift pressure (bar)	7	7	7
Lift temperature (°C)	90	90	90
OPTIONAL PACKAGE			
3bar pressure reducing valve	•	•	•
6 bar expansion relief valve	•	•	•
Expansion vessel ltr	5	5	5
15mm to 22mm Tundish	•	•	•
Isolation valve	•	•	•
PERFORMANCE			
Heat up time 15 to 65 °C (min)	120	145	180
Reheat time for 70% of contents (min)	84	101	126

2. COMPONENT CHECK LIST

The RD SERIES water heater comes with the following components, please check through the components supplied and ensure that all parts are present:

- a. Water Heater with 1.6 or 2kW sheathed heating elements, digital thermostat, and manual reset thermal cut-out
- b. T/P valve 7 bar 90°C
- c. Installation and user manual

Please contact our customer service department to know how to acquire the safety fittings.



3. GENERAL REQUIREMENTS

3.1. The RD SERIES domestic hot water cylinder MUST be installed by a competent person in accordance with section G3 of the current Building Regulations.

3.2. Important - It is important that the installer reads and understands these instructions, unpacks and familiarises themselves with the equipment before commencing the installation. Failure to observe these installation instructions could invalidate the warranty.

3.3. Water supply – The water supply to the cylinder should be potable water direct from a public mains water supply with any water treatment equipment functioning correctly.

For optimum performance the unit should be fed via a 15 mm diameter supply pipe direct from the mains water entry point to the property with supplies between 3 bar and 9 bar. The unit can operate with a minimum supply pressure of 1.5 bar and a flow rate of at least 20 litres per minute, but flow from the outlets will be low if several outlets are used simultaneously. The cylinder control equipment is factory set to limit the system operating pressure to 3 bar. The maximum supply pressure into the pressure-reducing valve is 9 bar.

3.4. Taps and fittings - All taps and fittings incorporated in the unvented system should have a rated operating pressure of 7 bar or above.

3.5. Location – The unit is designed to be vertically wall mounted, indoors, in a frost-free environment. When choosing a suitable location for the cylinder, consideration should be given to the routing of the discharge pipe to a convenient point and also the availability of an adequate power supply for connecting the sheathed heating elements.

The wall onto which the cylinder is mounted should be of good sound masonry construction capable of holding the weight of the cylinder when full of water (see *technical specifications* for weights).

The position of the cylinder should be such that easy access is provided for servicing the controls and replacing the sheathed heating element should the need arise.

Pipe runs should be made as short as possible and lagged to prevent heat loss.

To allow for servicing and repairs the unit must be mounted at least 300mm above any surface or object, so that access can be gained to electric connectors and the heating elements may be removed.

The unit should be mounted close to an external wall so that the discharge pipe D2 can be routed to a safe visible place.

The tundish should be mounted in a visible location so that it may easily be inspected.

3.6. Storage and handling – If the cylinder is not being installed immediately, it should remain in its carton with all pipe end protective caps in situ to prevent damage. We recommend that the cylinder be transported to its installation position with the outer carton in place.

3.7. Pipework connections – All Pipework connections to the cylinder MUST be made in accordance with Fig1.



4. PLUMBING INSTALLATION

4.1. Connections. Connections **MUST** be made to the cylinder in accordance with Fig 1, and Fig 2. A drain cock (not supplied) should be fitted in the position shown in Fig 1 to facilitate draining of the cylinder.

4.2. Cold water supply – For best results, the cylinder should be fed by an uninterrupted 15mm supply pipe into the pressure reducing valve (PRV) with a supply pressure of between 3 and 12 bar maximum. The cylinder should not be used on any system with a supply pressure below 1.5 bar and a flow rate of less than 20 litres per minute.

4.3. Temperature and pressure relief valve – The temperature and pressure relief valve (T&P Valve) is supplied separate. Once the valve is fitted should not be removed from the cylinder or tampered with in any way. The valve is pre calibrated to lift at 7 bar or 90 degrees centigrade and any attempt to adjust it will invalidate the warranty and could affect the safety performance of the unit.

The outlet of the T&P valve should be routed in 15mm copper piping in a downward direction alongside the water heating unit to the tundish. The outlet of the expansion relief valve must be T'd into this pipe before the tundish so that any water exiting either valve can be seen draining through the tundish – see fig 2

4.4. Pressure Reducing Valve – The pressure relief valve should be installed in the cold water supply to the water heating unit with the arrow pointing in the direction of water flow as shown in figure 1. This can be connected to a supply pressure of between 1.5 and 9 bar.

4.5 Expansion Relief Valve this must be installed between the pressure reducing valve and the water heating unit in accordance with Figure 1. No other valve should be fitted between this valve and the cylinder. The expansion relief valve contains a non return valve.

4.6. Expansion vessel – A suitable expansion vessel with a pre-charge pressure of 3 bar is supplied for fitting to all water heating units in the range. The expansion vessel **MUST** be fitted between the expansion relief valve and the cylinder. The expansion vessel **MUST** be positioned with the entry point at the bottom.

IMPORTANT: Regular checks must be carried out to ensure that the expansion vessel is correctly pressurised to 3 bar at all times. The expansion vessel should be installed using a standard t-connector between the expansion relief valve and the cylinder – see Figure 1.

4.7. Tundish – The tundish must not be positioned above or in close proximity of any electrical current carrying devices or wiring. The installation should conform with the requirements of item 4.9 below.



4.8 Connection arrangement for RD Series Cylinder

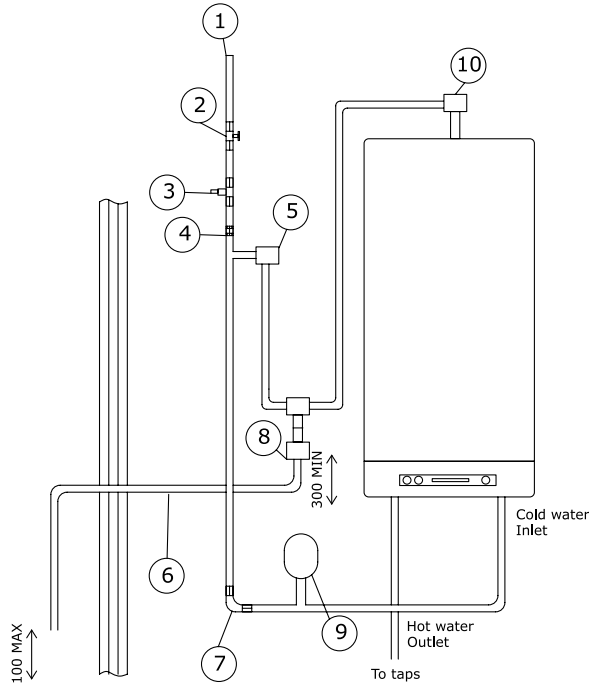

Fig 1

1	MAINS COLD WATER SUPPLY (15mm)
2	STOP COCK (NOT SUPPLIED)
3	PRESSURE REDUCING VALVE (OPTIONAL)
4	CHECK VALVE if supplied separately (included in RWC expansion relief valve)
5	EXPANSION RELIEF VALVE - SET 6 BAR (OPTIONAL)
6	DISCHARGE PIPE 22mm
7	DRAIN COCK (NOT SUPPLIED)
8	TUNDISH. (OPTIONAL)
9	EXPANSION VESSEL. (OPTIONAL)
10	T/P RELIEF VALVE. (SUPPLIED)

4.9. Discharge arrangement.

The Tundish must be installed in a position so that it is clearly visible by the user. In addition, the discharge pipe from the Tundish should terminate in a safe place where there is no risk to persons in the vicinity of the discharge, be of metal and:

- (a) Be at least one pipe size larger than the normal outlet size of the safety device unless its total equipment hydraulic resistance exceeds that of a straight pipe 9 m long, i.e. discharge pipes between 9 m and 18 m equivalent resistance length should be at least two sizes larger than the normal outlet size of the safety device, between 18 m and 27 m at least three sizes larger and so on. Bends must be taken into account in calculating the flow resistance. Refer to the diagram, tables and worked example detailed below.
- (b) Have a vertical section of pipe at least 300 mm long below the Tundish before any elbows or bends in the Pipework.
- (c) Be installed with a continuous fall
- (d) Have discharges visible at both Tundish and the final point of discharge, but where this is not possible or practically difficult, examples of acceptable discharge arrangements are:
- Ideally below a fixed grating and above the water seal in a trapped gully
 - Downward discharge at low level, i.e. up to 100 mm above external surfaces such as car parks, hard standings, grassed areas, etc. are acceptable providing that where children play or otherwise come into contact with discharges, a wire cage or similar guard is positioned to prevent contact whilst maintaining visibility.
 - Discharge at high level, e.g. into a metal hopper and metal down pipe with the end of the discharge pipe clearly visible (Tundish visible or not) or onto a roof capable of withstanding high temperature discharges of water and 3 m from any plastic guttering system that would collect such discharges (Tundish visible).
 - Where a single pipe serves a number of discharges such as in blocks of flats, the number served should be limited to not more than six systems so that any installation discharging can be traced reasonably easily. The single common discharge pipe should be at least one pipe size larger than the largest individual discharge pipe to be connected. If unvented hot water storage systems are installed where discharges from safety devices may not be apparent i.e. in dwellings occupied by blind, or disabled people, consideration should be given to the installation of an electrically operated device to warn when discharge takes place.

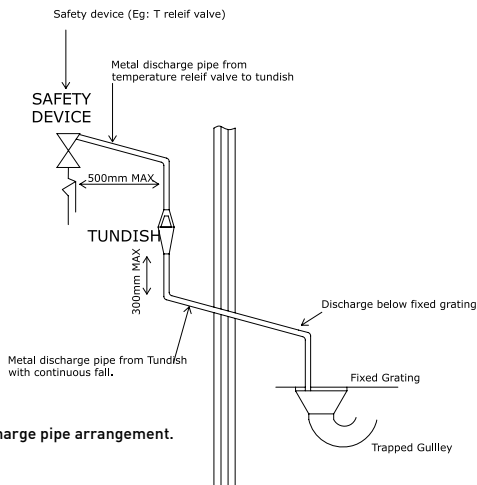

Fig 2 - Typical discharge pipe arrangement.



Warning Notice – The discharge will consist of scalding water and steam. Asphalt, roofing felt and non-metallic rainwater goods may be damaged by such discharges.

SIZING OF COPPER DISCHARGE PIPE "D2" FOR COMMON TEMPERATURE RELIEF VALVE OUTLET SIZES				
Valve outlet size (diameter, inches)	Min size of discharge pipe D1 (mm)	Min size of discharge pipe D2 from tundish (mm)	Max resistance allowed, expressed as a length of straight pipe, i.e. no elbows or bends	Resistance created by each elbow or bend (m)
1/2	15	22	up to 9	0.8
		28	up to 18	1.0
		35	up to 27	1.4
3/4	22	28	up to 9	-
		35	up to 18	-
		42	up to 27	1.7
1	28	35	up to 9	1.4
		42	up to 18	1.7
		54	up to 27	2.3

Worked example

The example below is for a 1/2" diameter temperature relief valve with a discharge pipe (D2) having 4 22mm elbows and a length of 7 m from the tundish to the point of discharge.

The maximum resistance allowed for a straight length of 22mm copper discharge pipe (D2) from a 1/2" diameter temperature relief valve is: 9.0 m.

Subtract the resistance for 4 No 22mm elbows at 0.8 m each = 3.2 m.

Therefore, the maximum permitted length equates to: 5.8 m.

5.8 m is less than the actual length of 7 m, therefore, calculate the next largest size.

Maximum resistance allowed for a straight length of 28mm pipe (D2) from a 1/2" diameter temperature relief valve equates to: 18 m.

Subtract the resistance for 4 No 28mm elbows at 1.0 each = 4 m.

Therefore the maximum permitted length equates to 14 m.

As the actual length is 7 m, a 28mm diameter copper pipe will be satisfactory.

5. ELECTRICAL INSTALLATION

WARNING: THIS EQUIPMENT MUST BE EARTHED.

All electrical wiring must be carried out by a competent person and in accordance with the **current I.E.E. Wiring Regulations**. All pipework should be earthed!

5.1. The sheathed heating element - A 1.6 or 2kW 230v 50Hz sheathed heating element is pre fitted to the cylinder at the factory. It should be wired in accordance with the instructions given in Fig 3.

5.2. Wiring instructions

a) The power supply to the heater must be via a double pole isolator switch or controller, having contact separation of at least 3 mm, using 1.5mm sq. flexible cable, to comply with BS 6141 and must be fully earthed. Wire the water heater in accordance with the wiring diagram below:

- i. Connect the Earth wire to the terminal on the cylinder marked with the earth symbol.
- ii. Connect the Live wire to the high temperature cut-out terminal
- iii. Connect the Neutral wire to the high temperature cut-out terminal

WARNING: DO NOT SWITCH ON THE ELECTRICITY SUPPLY UNTIL INSTRUCTED TO DO SO IN THE COMMISSIONING PROCEDURE AND THE UNIT IS FULL OF WATER.

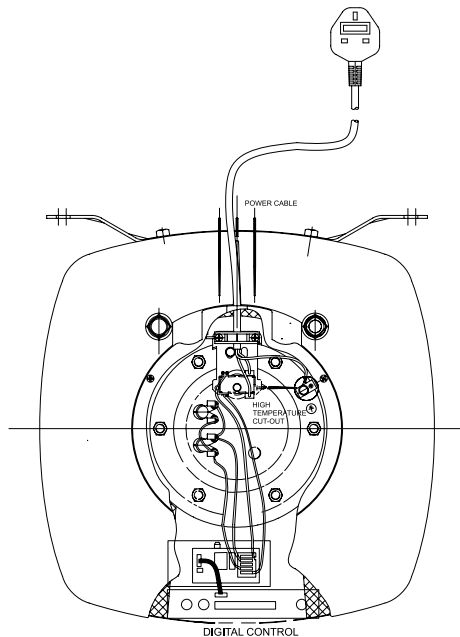

Fig 3

WARNING: THIS APPLIANCE MUST BE EARTHED.



6. FILLING AND COMMISSIONING

- 6.1. Check that the expansion vessel charge pressure is 3 bar.
- 6.2. Check that all water and electric connections are tight and correctly configured.
- 6.3. Open the main stopcock and fill the unit. Open successive hot taps starting with the tap furthest from the heater. Leave each tap open for a few moments to allow all air and debris from the system to exit. Close all of the taps.
- 6.4. Turn off the mains water supply to the cylinder and drain the system through the drain cock.
- 6.5. Refill the cylinder with hot taps open and close when water flows freely.
- 6.6. Manually lift (by rotating the knob) both the expansion relief and the temperature and pressure relief valves for a short period to remove trapped air from behind the valve seating and to check the correct function of the discharge arrangement.
- 6.7. Check all joints for leaks and rectify as necessary.
- 6.8. With the heater full of water, turn the thermostat to a point just below its mid point setting and switch on the electricity supply. Check that the cylinder heats the water and the thermostat operates when the set temperature is reached. Turn on the hot taps to check that warm water is delivered.
- 6.9. Check that while the unit is heating up, no water exits from either the expansion relief valve or the temperature and pressure relief valve. If water does exit through the valves check the expansion vessel pressure and installation.
- 6.10. Increase the temperature to maximum and allow the unit to heat and the temperature to stabilise. Check that no water discharges from the valves. Turn on the hot taps to drain the heater of hot water. Set the thermostat to the required temperature and allow the heater to reheat ready for use.

7. SERVICING AND MAINTENANCE

- 7.1. Servicing and maintenance must only be carried out by a competent unvented hot water heater installer or by Rointe authorised personnel.
- 7.2. Before any work whatsoever is carried out on the installation, it MUST first be isolated from the mains electricity supply.
- 7.3. Only use spare parts authorised by Rointe. The use of other parts will invalidate the warranty.
- 7.4. Drain the cylinder – When draining the cylinder, always switch off the boiler and the heating element first. Turn off the water supply at the stopcock (see Fig 1). Connect a hosepipe to the drain cock (see Fig 1) and route it to a convenient gully. Open the drain cock and all hot taps that are served by the cylinder. The cylinder may take several minutes to empty completely.
- 7.5. In hard water areas it may be necessary from time to time to replace the magnesium anode.
- 7.6. Remove the cartridge from the pressure reducing valve. Check the strainer and if necessary remove any debris from in front of it. Replace the cartridge.



7.7. Check the charge pressure in the expansion vessel and top up as necessary. The charge pressure should be 3.0 bar.

7.8. Close the drain cock, disconnect the hose, refit the heating element and close all hot water taps before reopening the stopcock. Allow the cylinder time to fill whilst checking for any leaks. Release any air from the system by opening each hot water tap individually, starting with the one furthest from the cylinder.

7.9. Manually lift the expansion relief and temperature and pressure relief valve one at a time, every 12 months (more frequently in hard water areas) to prevent debris from building up behind the valve seat. Whilst carrying out this operation, check that the discharge to waste is unobstructed. Check that each valve seals correctly when released. As the valves are pre-calibrated, they require no further maintenance.

7.10. Finally, when the heater is full of water switch on the mains electricity supply to the heating element and the boiler. As the system heats up, check again for any leaks and rectify as necessary.

7.11. In the event of the manual reset cut-out operating, isolate the heater from the mains supply, investigate and identify the cause of the operation of this cut-out, rectify the fault before manually resetting the cut-out via the reset button on the cut-out. Finally switch the mains electricity supply back on.

8. FAULT FINDING

Notice: Disconnect electrical supply before removing any electrical equipment cover.

FAULT	POSSIBLE CAUSE	REMEDY
No hot water	<ol style="list-style-type: none"> 1. Mains supply off 2. Strainer in Pressure reducing valve blocked 3. Pressure reducing valve incorrectly fitted 	<ol style="list-style-type: none"> 1. Open stopcock 2. Turn water supply off, remove strainer and clean. 3. Re-fit correctly
Water from hot taps is cold	<ol style="list-style-type: none"> 1. Programmer if fitted is not switched on. 2. High limit thermostat has tripped 	<ol style="list-style-type: none"> 1. Switch on the programmer 2. Check and re-set
Intermittent water discharge through tundish on warm-up	<ol style="list-style-type: none"> 1. Expansion vessel has lost its charge pressure 	<ol style="list-style-type: none"> 1. Turn off stopcock, open a hot water tap, check vessel charge pressure and recharge to 3 bar
Continuous water discharge	<ol style="list-style-type: none"> 1. Pressure reducing valve (PRV) not working 2. Expansion relief valve not seating correctly 3. Temperature and pressure relief valve not seating correctly 	<ol style="list-style-type: none"> 1. Check pressure from Pressure reducing valve if greater than 3 bar replace cartridge 2. Manually lift the valve once or twice to clear any debris from the seat otherwise replace valve



9. USER INSTRUCTIONS

9.1. Your RD Series unvented hot water cylinder has been designed to give many years of trouble free service.

9.2. When a hot tap is turned on there may be a short surge of water, this is quite normal with unvented systems and does not mean there is a fault.

9.3. When you first fill a basin the water may sometimes appear milky. This is due to very tiny air bubbles in the water which will clear very quickly.



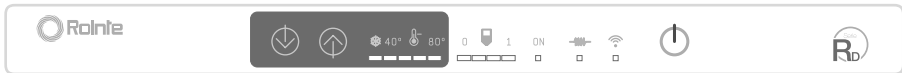

9.4. If water is seen dripping through the tundish at any time switch off the electricity supply immediately and call the installer or the Rointe customer service department on the number listed at the end of this guide.

9.5 Front panel description

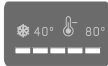

The following image shows how the front panel of the water heater looks.



9.5.1 Front panel indicators

SECTION	DESCRIPTION
	Set temperature indicator
	Amount of hot water available
	ON / STAND BY indicator
	Heater element in use indicator
	Active communication indicator (not in use at the moment)

9.5.2 Front panel touchpad



SECTION	DESCRIPTION
	Increase set temperature button
	Decrease set temperature button
	ON / STAND BY button



9.6 Working the RD series Water Heater



The RD series water heater is set in the factory to Stand by. Due to this, for the heater to work once installed press the ON button .

9.7 On and Stand-by



When you press  a beep will sound and the indicators will toggle between on and stand-by. In stand-by mode the LED indicator  will be brightly lit. When the heater is on, the indicator show that the RD series water heater is on.

NOTE: When the RD series water heater is on "Stand By", it is still connected to the electricity supply, but won't have any active operation.



9.8 Setting the temperature





We can elect to set the temperature by pressing the buttons  and .

When pressing the button , the temperature setting is increased.

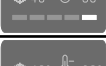
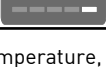
You will hear a beep and the LED will light up the display  starting from the left at anti-frost  and advancing to the right .

The temperatures that can be set and seen on the display are shown in the following table:

DISPLAY	TEMPERATURE
	8°
	40°
	50°
	60°
	80°

In order to decrease the set temperature, press the button  and you will hear a beep. The LED will switch off  starting from the right  and finishing on the left in anti-frost mode .

The temperature is controlled using the Rointe **Optimizer Energy Plus** that activates and deactivates the electric current passing through the heater element in order to efficiently heat the water in the heater and the heater in use LED lights up .



9.9 Fault Warnings

During normal equipment use, without any intervention by the user it is possible to detect faults which are shown using the LEDs.

9.9.1 Temperature probe failure

When the temperature probe fails, the temperature setting LEDs flash every half a second.

9.9.2 Element failure

When an element fails, the heater in use LED  flashes every half a second.

9.9.3 System reset

In order to reset the RD series water heater, press the  button for 10 seconds and you will immediately access the reset option.

The four LEDs that show the amount of hot water available will be flashing. and when you press the  button, the system will be reset and return to the factory settings.

9.10 Energy tracking by using the optimizer

This product can be incorporated into the software of the ROINTE Optimizer Energy Plus.



10. WARRANTY

10.1. Rointe guarantee all electrical and mechanical controls supplied with the cylinder for a period of 2 years from the date of purchase provided that they have been installed for their intended use by a competent person and have not been modified in any way.

10.2. In addition Rointe also guarantees the hot water cylinder for a period of 5 years from the date of purchase against faulty material or manufacture provided that:

- a) It has been installed by a competent person in accordance with this installation manual and all current regulations and codes of practice at the time of installation.
- b) It has been used solely for the purpose of heating potable water that complies with current (at the time of installation) EU standards and is not fed with water from a private source.
- c) It has not been modified in any way.
- d) It has not been subjected to excessive pressure or electrolytic action from dissimilar materials, or attack from any salt deposits.
- e) It has been installed indoors in a frost-free environment.
- e) The warranty card is completed and returned to Rointe within 90 days of installation.

This warranty is not transferable. This warranty does not include claims due to frost or lime scale damage. Proof of purchase will be required against any claim. This guarantee does not affect your statutory rights.

For help about the RD Series please contact the Rointe Customer Services Department:

Tlf: 0845 604 5987

Fax: 0208 953 5861



11. INSTALLATION, COMMISSIONING AND SERVICE RECORD

CUSTOMER DETAILS	
NAME	
ADDRESS	
TEL No.	
INSTALLER DETAILS	
COMPANY NAME	DATE
ADDRESS	
TEL No.	
INSTALLER NAME	REGISTRATION No.
COMMISSIONING ENGINEER (IF DIFFERENT)	
COMPANY NAME	DATE
ADDRESS	
TEL No.	
INSTALLER NAME	REGISTRATION No.
CYLINDER DETAILS	
MODEL	
CAPACITY (litres)	SERIAL NO.



SERVICE RECORD DETAILS

Before completing the appropriate Service Interval Record below, please ensure you have carried out the service as described in the manufacturer's instructions and in compliance with all relevant codes of practice.

It is recommended that your hot water system is serviced regularly and that your service engineer completes the appropriate Service Interval Record below.

SERVICE 1 DATE:	SERVICE 2 DATE:
SERVICE ENGINEER	SERVICE ENGINEER
TEL NO.	TEL NO.
REGISTRATION NO.	REGISTRATION NO.
SIGNATURE	SIGNATURE

SERVICE 3 DATE:	SERVICE 4 DATE:
SERVICE ENGINEER	SERVICE ENGINEER
TEL NO.	TEL NO.
REGISTRATION NO.	REGISTRATION NO.
SIGNATURE	SIGNATURE

SERVICE 5 DATE:	SERVICE 6 DATE:
SERVICE ENGINEER	SERVICE ENGINEER
TEL NO.	TEL NO.
REGISTRATION NO.	REGISTRATION NO.
SIGNATURE	SIGNATURE

SERVICE 7 DATE:	SERVICE 8 DATE:
SERVICE ENGINEER	SERVICE ENGINEER
TEL NO.	TEL NO.
REGISTRATION NO.	REGISTRATION NO.
SIGNATURE	SIGNATURE





ROINTE UK
Catalyst House
720 Centennial Court
Centennial Park
Elstree, Herts, WD6 3SY.

CUSTOMER SERVICE
T. 0845 604 5987

FAX NUMBER
F. 0208 953 5861

e-mail: rointe@rointe.co.uk
www.rointe.co.uk