

ACME[®]

DMX512

LINKABLE

STAND ALONE



REVOLVER

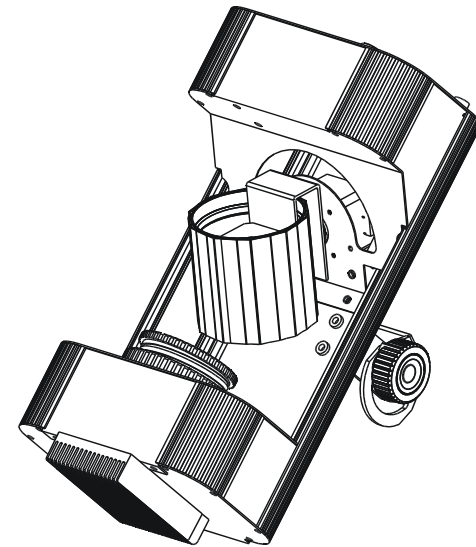

LED-BR10

User Manual

Professional Entertainment Technology

Innovation, Quality, Performance

EC - Declaration of Conformity

We declare that our products (lighting equipments) comply with the following specification and bears CE mark in accordance with the provision of the Electromagnetic Compatibility (EMC) Directive 89/336/EEC.

EN55014-2: 1997 A1: 2001, EN61000-4-2: 1995; EN61000-4-3: 2002;

EN61000-4-4: 1995; EN61000-4-5: 1995, EN61000-4-6: 1996,

EN61000-4-11: 1994.

&

Harmonized Standard

EN60598-1: 2000+ALL: 2000+A12: 2002

Safety of household and similar electrical appliances

Part 1: General requirements

4. Try another DMX controller.
5. Check if the DMX cables run near or run alongside to high voltage cables that may cause interference to DMX interface circuit.

C. Some fixtures don't respond to the easy controller

1. Check the LED for the response of the master/ slave mode signal.
2. Check if the unit is receiving a DMX signal and disconnect it.

D. No response to the sound

1. Make sure the fixture is not receiving a DMX signal.
2. Check microphone to see if it is good by tapping the microphone.

8. Fixture Cleaning

The cleaning of internal and external optical lenses and/or mirrors must be carried out periodically to optimize light output. Cleaning frequency depends on the environment in which the fixture operates: damp, smoky or particularly dirty surrounding can cause greater accumulation of dirt on the unit's optics.

- Clean with soft cloth using normal glass cleaning fluid.
- Always dry the parts carefully.
- Clean the external optics at least every 20 days. Clean the internal optics at least every 30/60 days.

TABLE OF CONTENTS

1. Safety Instruction

2. Technical Specification

3. Installation

4. How to Control the Unit

4.1 Control Panel

4.2 Master/Slave operation

4.3 Easy controller

4.4 Universal DMX controller

5. DMX 512 Configuration

6. DMX 512 Connection

7. Trouble Shooting

8. Fixture Cleaning

1. Safety Instruction



WARNING

Please read the instruction carefully which including important information about the installation, operation and maintenance.

- Please keep this User Manual for future consultation. If you sell the unit to another user, be sure that they also receive this instruction booklet.
- Unpack and check carefully there is no transportation damage before using the unit.
- Before operating, ensure that the voltage and frequency of power supply match the power requirements of the unit.
- It's important to ground the yellow/green conductor to earth in order to avoid electric shock.
- The unit is for indoor use only and use only in a dry location.
- The unit must be installed in a location with adequate ventilation, at least 50cm from adjacent surfaces. Be sure that no ventilation slots are blocked.
- Disconnect mains power before fuse replacement or servicing.
- Replace fuse only with the same type.
- Make sure there are not flammable materials close to the unit while operating as it is fire hazard.
- Use safety cable when fixes this unit.
- Maximum ambient temperature is TA: 40 °C and don't operate it where the temperature is higher than this.
- There are no user serviceable parts inside the fixture. Do not open the housing or attempt any repairs by yourself. In the unlikely event your fixture may require service, please contact the nearest authorized technical assistance center and always use the same type spare parts.
- Don't connect the unit to any dimmer pack or power pack.
- Do not look directly at the LED light beam while the fixture is on.
- The housing must be replaced if they are visibly damaged.
- Do not touch any wire during operation as high voltage may cause electric shock.

Power supply: Do not connect in series more than 20 units, use another mains supply for next 20 units.

- 1.If you using a controller with 5 pin DMX output, you need to use a 5 to 3 pin adapter-cable.
 - 2.In the last unit, the DMX cable has to be terminated with a terminator. Solder a 120 ohm 1/4W resistor between pin 2(DMX-) and pin 3(DMX+) into a 3-pin XLR-plug and plug it in the DMX-output of the last unit.
 - 3.Connect the unit together in a 'daisy chain' with the XLR plug from the output of the unit to the input of the next unit. The cable can not be branched or split to a 'Y' cable. DMX 512 is a very high-speed signal. Inadequate or damaged cables, bad solder joints or corroded connectors can easily distort the signal and shut down the system.
 - 4.The DMX output and input connectors pass-through to maintain the DMX circuit, when power is connected to the unit.
 - 5.Each lighting unit needs to have an address set to receive the data sent by the controller. The address number is between 0-512 (usually 0 & 1 are equal to 1).
 - 6.The end of the DMX 512 system should be terminated to reduce signal errors.
- 7.3 pin XLR: Pin 1: GND, Pin 2: Negative signal (-), Pin 3: Positive signal (+)
5 pin XLR: Pin 1: GND, Pin 2: Negative signal (-), Pin 3: Positive signal (+)
Pin 4/5: Not used.

7. Troubleshooting

Following are a few common problems that may occur during operation. Here are some suggestions for easy troubleshooting:

A. The fixture does not work, no light

1. Check the connection of power and main fuse.
2. Measure the mains voltage on the main connector.

B. Not responding to DMX controller

1. DMX LED should be on. If not, check DMX connectors, cables to see if linked properly.
2. If the DMX LED is on and no response to the channel, check the address settings and DMX polarity.
3. If you have intermittent DMX signal problems, check the cables or PCB of the fixture or the previous one.

5. DMX 512 Configuration

DMX Configuration				
5 Channel mode				
Ch1	Ch2	Ch3	Ch4	Ch5
Pan	Barrel	Strobe	Color	Dimmer
255 0	246-255 Stop Fast ↑ 135-245 Slow Rotation ↓ 121-134 Stop Slow ↓ 010-120 Fast Rotation ↓ 000-009 Stop	240-255 Open Random strobe 232-239 Open 190-231 Slow close fast open 182-189 Open 140-181 Fast close slow open 132-139 Open 008-131 ⚡ ⚡ ⚡ 000-009 Open	241-255 Red+Green+Blue+White 225-240 Green+Blue+White 208-224 Red+Blue+White 192-207 Red+Green+White 175-191 Red+Green+Blue 158-174 Blue+White 142-157 Green+White 125-141 Green+Blue 108-124 Red+White 092-107 Red+Blue 075-091 Red+Green 058-074 White 042-057 Blue 025-041 Green 008-024 Red 000-007 Black Out	255 100% 0 0%

6. DMX 512 Connection

The DMX 512 is widely used in intelligent lightings and with a maximum of 512 channels.

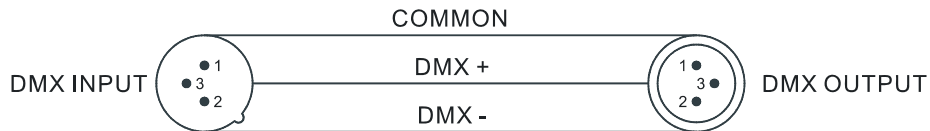
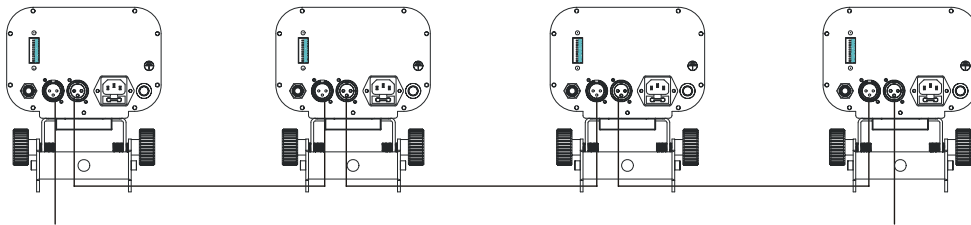

Termination reduces signal errors and avoids signal transmission problems and interference. It is always advisable to connect a DMX terminal.

(Resistance 120 ohm 1/4W) between pin2(DMX-) and pin3(DMX+) of the last fixture.



2. Technical Specification

- It can be operated by DMX512 control or can be used as an individual unit without controller.
- Please use a 3 pin XLR cable/plug in master/slave mode.
- Smooth 0-100% dimming, and variable strobe speed.
- 5 Channels
Channel 1 = Pan
Channel 2 = Barrel
Channel 3 = Strobe
Channel 4 = Color
Channel 5 = Dimmer

- **Voltage:** AC 100-240V~50/60Hz
- **Fuse:** T 2A
- **LED:** 1 x 10W LED
- **Power Consumption:** 26W
- **Dimension:** 331 x 135 x 170 mm
- **Weight:** 3.4kg

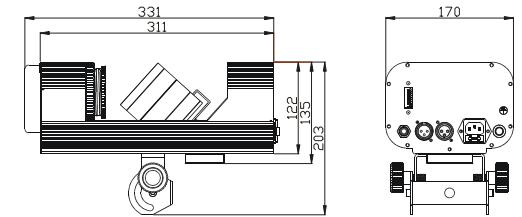

3. Installation

The unit should be mounted via its screw hole on the bracket. Always ensure that the unit is firmly fixed to avoid vibration and slipping while operating. Always ensure that the structure to which you are attaching the unit is secure and is able to support a weight of 10 times of the unit's weight. Also always use a safety cable that can hold 12 times of the weight of the unit when installing the fixture.

The equipment must be fixed by professionals and it must be fixed in a place where is out of the reach of people and no one can pass under it.

4. How To Control The Unit

4.1 Control Panel

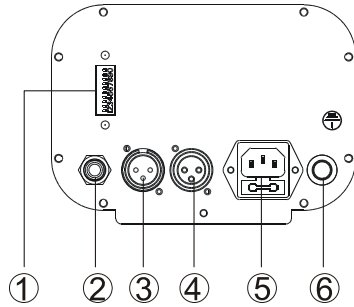

- ① **Dip switches:** For different function setting.
- ② **Only for remote control:** Connecting with CA-8/CA-9/CA-9RTX to control the unit for Stand by, Function and Mode function.
- ③ **DMX output:** For DMX512 link, use 3/5-pin XLR plug cable to link the next unit.
- ④ **DMX input:** For DMX512 link, use 3/5-pin XLR plug cable to input DMX signal.
- ⑤ **Power:** Connect to supply mains power.
- ⑥ **Microphone:** Receives the sound to control the unit

4.2 Master/Slave Operation

The unit can be linked together in a daisy chain with as many units as you need in master/slave mode to perform the great built-in pre-programmed lighting shows triggered by the music.

In Master/Slave mode refer to the DMX settings below:

Master unit: DMX start address MUST be set to 001. (First DIP switch = ON, all others are OFF)

Slave units: DMX start address may have any value but NOT 001 (example: set the first 3 DIP switches to ON)

2-Light Show

Dipswitch 10 "off" means the unit works normally and "on" means 2-Light show. In order to create a great light show, you can set dip switch 10 "on" on any unit that is linked to the master unit to get contrast movement to the master unit, even if you have two units only. Dipswitch 10 on the first (Master) unit will not function for the 2-light show as it is the

master unit that operates the light show.

4.3 Easy Controller (by CA-8/CA-9/CA-9RTX)

The easy remote control is used only in master/slave mode. By connecting to the 4-pin plug of the first unit, you will find that the remote controller on the first unit will control all the other units for Stand by, Function and Mode selection

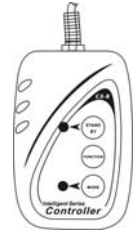

Stand by	Blackout the unit		
Function	1. Synchronous Strobe in white 2. Sound strobe in white 3. Sound Strobe in color	Select Color	Select Show 1-6
Mode	Strobe (LED OFF)	Show (LED ON)	LED blinking

4.4 Universal DMX Controller

When using a universal DMX controller to control the chain of units, you have to set DMX address by Dip switches from 1 to 9 to make sure all the units will receive its DMX signal. The dip switch 10 is used to choose channel mode. Please refer to the following diagram to know how to address your DMX 512 system in the binary code.

DMX 512 Address Chart:

Dip-switches	# 1	# 2	# 3	# 4	# 5	# 6	# 7	# 8	# 9	#10
Value	1	2	4	8	16	32	64	128	256	2-Light show

• Examples:

Unit 1: dip / on: #1 (=1)

Unit 2: dip / on: #2, #3 (2+4=6)

Unit 3: dip / on: #1, #2, #4 (1+2+8=11)

Unit 4: dip / on: #5 (=16)

Channel	Dip switches setting
1	↓ ON <input checked="" type="checkbox"/> <input type="checkbox"/> <input type="checkbox"/> <input type="checkbox"/> <input type="checkbox"/> <input type="checkbox"/> <input type="checkbox"/> <input type="checkbox"/> <input type="checkbox"/> <input type="checkbox"/> <input type="checkbox"/>
6	↓ ON <input checked="" type="checkbox"/> <input checked="" type="checkbox"/> <input type="checkbox"/> <input type="checkbox"/> <input type="checkbox"/> <input type="checkbox"/> <input type="checkbox"/> <input type="checkbox"/> <input type="checkbox"/> <input type="checkbox"/> <input type="checkbox"/>
11	↓ ON <input checked="" type="checkbox"/> <input checked="" type="checkbox"/> <input checked="" type="checkbox"/> <input type="checkbox"/> <input type="checkbox"/> <input type="checkbox"/> <input type="checkbox"/> <input type="checkbox"/> <input type="checkbox"/> <input type="checkbox"/> <input type="checkbox"/>
16	↓ ON <input type="checkbox"/> <input type="checkbox"/> <input type="checkbox"/> <input type="checkbox"/> <input checked="" type="checkbox"/> <input type="checkbox"/> <input type="checkbox"/> <input type="checkbox"/> <input type="checkbox"/> <input type="checkbox"/> <input type="checkbox"/>