



Operation and Safety Manual

Original Instructions - Keep this manual with the machine at all times.

Model
15AMI

ANSI



P/N - 3121212

January 5, 2010

FOREWORD

This manual is a very important tool! Keep it with the machine at all times.

The purpose of this manual is to provide owners, users, operators, lessors, and lessees with the precautions and operating procedures essential for the safe and proper machine operation for its intended purpose.

Due to continuous product improvements, JLG Industries, Inc. reserves the right to make specification changes without prior notification. Contact JLG Industries, Inc. for updated information.

SAFETY ALERT SYMBOLS AND SAFETY SIGNAL WORDS



This is the Safety Alert Symbol. It is used to alert you to the potential personal injury hazards. Obey all safety messages that follow this symbol to avoid possible injury or death

⚠ DANGER

INDICATES AN IMMINENTLY HAZARDOUS SITUATION. IF NOT AVOIDED, WILL RESULT IN SERIOUS INJURY OR DEATH. THIS DECAL WILL HAVE A RED BACKGROUND.

⚠ WARNING

INDICATES A POTENTIALITY HAZARDOUS SITUATION. IF NOT AVOIDED, COULD RESULT IN SERIOUS INJURY OR DEATH. THIS DECAL WILL HAVE AN ORANGE BACKGROUND.

⚠ CAUTION

INDICATES A POTENTIALITY HAZARDOUS SITUATION. IF NOT AVOIDED, MAY RESULT IN MINOR OR MODERATE INJURY. IT MAY ALSO ALERT AGAINST UNSAFE PRACTICES. THIS DECAL WILL HAVE A YELLOW BACKGROUND.

WARNING

THIS PRODUCT MUST COMPLY WITH ALL SAFETY RELATED BULLETINS. CONTACT JLG INDUSTRIES, INC. OR THE LOCAL AUTHORIZED JLG REPRESENTATIVE FOR INFORMATION REGARDING SAFETY RELATED BULLETINS WHICH MAY HAVE BEEN ISSUED FOR THIS PRODUCT.

NOTICE

JLG INDUSTRIES, INC. SENDS SAFETY RELATED BULLETINS TO THE OWNER OF RECORD OF THIS MACHINE. CONTACT JLG INDUSTRIES, INC. TO ENSURE THAT THE CURRENT OWNER RECORDS ARE UPDATED AND ACCURATE.

NOTICE

JLG INDUSTRIES, INC. MUST BE NOTIFIED IMMEDIATELY IN ALL INSTANCES WHERE JLG PRODUCTS HAVE BEEN INVOLVED IN AN ACCIDENT INVOLVING BODILY INJURY OR DEATH OF PERSONNEL OR WHEN SUBSTANTIAL DAMAGE HAS OCCURRED TO PERSONAL PROPERTY OR THE JLG PRODUCT.

For :

- Accident Reporting
- Product Safety Publications
- Current Owner Updates
- Questions Regarding Product Safety
- Standards and Regulations Compliance Information
- Questions Regarding Special Product Applications
- Questions Regarding Product Modifications

Contact :

Product Safety and Reliability Department
JLG Industries, Inc.
13224 Fountainhead Plaza
Hagerstown, MD 21742

or Your Local JLG Office
(See addresses on manual rear cover)

In USA:

Toll Free: 877-JLG-SAFE (877-554-7233)

Outside USA:

Phone: 240-420-2661
E-mail: ProductSafety@JLG.com

REVISION LOG

Original Issue of Manual July 6, 2005
Manual Revised July 28, 2006
Manual Revised December 1, 2008
Manual Revised January 5, 2010

TABLE OF CONTENTS

SECTION - PARAGRAPH, SUBJECT	PAGE	SECTION - PARAGRAPH, SUBJECT	PAGE
FOREWORD	A	2.2 PREPARATION, INSPECTION, AND MAINTENANCE	2-2
SAFETY ALERT SYMBOLS AND SAFETY SIGNAL WORDS	B	2.3 PRE-START INSPECTION	2-4
Contact :	C	2.4 FUNCTION CHECK	2-5
In USA:	C	2.5 DAILY WALK-AROUND INSPECTION	2-5
Outside USA:	C	General	2-5
REVISION LOG	D		
SECTION - 1 - SAFETY PRECAUTIONS		SECTION - 3 - MACHINE CONTROLS & INDICATORS	
1.1 GENERAL	1-1	3.1 GENERAL	3-1
1.2 TRANSPORTING	1-2	3.2 CONTROLS AND INDICATORS	3-1
Transport Safety	1-2	Ground Control Station	3-1
1.3 PRE-OPERATIONAL SAFETY	1-5	Platform Control Station	3-4
1.4 OPERATING SAFETY	1-6	3.3 DECAL INSTALLATIONS	3-6
Electrocution Hazard	1-7		
1.5 MAINTENANCE SAFETY PRECAUTIONS	1-10	SECTION - 4 - MACHINE OPERATION	
SECTION - 2 - USER RESPONSIBILITIES, MACHINE PREPA- RATION, AND INSPECTION		4.1 DESCRIPTION	4-1
2.1 PERSONNEL TRAINING	2-1	4.2 OPERATING CHARACTERISTICS AND LIMITATIONS	4-1
Operator Training	2-1	Capacities	4-1
Training Supervision	2-1	4.3 BATTERY CHARGING & MAINTENANCE	4-2
Operator Responsibility	2-1	Battery Maintenance and Safety	4-2
		Battery Charger Operation	4-3
		Abnormal Cycle Indicator LED	4-4

TABLE OF CONTENTS

SECTION - PARAGRAPH, SUBJECT	PAGE	SECTION - PARAGRAPH, SUBJECT	PAGE
4.4 MACHINE SET-UP AND OPERATION	4-5	Extra Power Pack (DC Battery, Charger & Case) . .	5-1
Floor Brake Operation	4-5	Lifting Hook	5-2
Platform Loading	4-6	Platform Auxiliary Power Lowering Device	5-2
Platform Operation	4-6	Laser Positioning Device	5-2
4.5 QUICK-CHANGE PLATFORM	4-7	Locking Swivel Caster Wheels	5-2
Platform Removal	4-7	Programmable Security Lock	5-2
Platform Installation	4-7	Descent Alarm	5-2
4.6 STOWING MACHINE	4-9	Descent Warning Strobe	5-2
4.7 TRANSPORTING, LIFTING AND TIE DOWN	4-9	Hourmeter	5-3
General	4-9	Machine Cycle Counter Meter	5-3
Transporting by Pushing	4-9	5.2 EXTENDIBLE PLATFORM OPERATION	5-4
Lifting	4-10	Mounting to Mast	5-4
Transport Vehicle Tie Down	4-11	Entering/Exiting Platform	5-4
		Extending Platform	5-4
		Retracting Platform	5-5
SECTION - 5 - OPTIONAL EQUIPMENT		5.3 PROGRAMMABLE SECURITY LOCK(PSL™)(OPTION) .	5-6
5.1 OPTIONAL EQUIPMENT	5-1	PSL™ Box Location	5-6
22" x 25" Quick-Change Platform	5-1	Machine Power Up using the PSL™	5-7
26" x 26" Quick-Change Platform	5-1	Machine Power Down	5-7
28" x 26" Quick-Change Platform	5-1	Changing the Operator's Code	5-7
25" x 26" Step-in Molded Platform -			
w/Swing-up Gate	5-1		
26" x 50" Quick-Change - ExtendiblePlatform.	5-1		
Tool Tray	5-1	SECTION - 6 - EMERGENCY PROCEDURES	
Fluorescent Tube Caddy	5-1	6.1 GENERAL INFORMATION	6-1
		6.2 EMERGENCY OPERATION	6-1

TABLE OF CONTENTS

SECTION - PARAGRAPH, SUBJECT	PAGE
Operator Unable to Control Machine	6-1
Platform Caught Overhead	6-1
Righting of Tipped Machine	6-1
6.3 INCIDENT NOTIFICATION	6-2

SECTION - 7 - GENERAL SPECIFICATIONS AND OPERATOR MAINTENANCE

7.1 INTRODUCTION	7-1
7.2 GENERAL SPECIFICATIONS	7-2
Machine Specifications	7-2
Electrical Specifications	7-3
Platform Data	7-4
Machine Component Weights	7-5
Serial Number Locations	7-5
7.3 OPERATOR MAINTENANCE	7-6
Battery Maintenance	7-6
Lubrication	7-7
7.4 SUPPLEMENTAL INFORMATION	7-10

SECTION - 8 - INSPECTION AND REPAIR LOG

SECTION - PARAGRAPH, SUBJECT	PAGE
------------------------------	------

LIST OF FIGURES

2-1. Daily Walk-Around Inspection.	2-7
3-1. Ground Control Station.	3-2
3-2. Manual Descent Control Valve Location - Machines Built Since S/N- 0900019526	3-3
3-3. Platform Control Station.	3-4
3-4. Decal Installation. (ANSI and CSA Specification	3-6
3-5. Decal Installation. (CE Specification)	3-8
4-1. Battery Fluid Level.	4-2
4-2. Battery Box and Charger Assembly.	4-3
4-3. Dual Voltage Charger - Front Panel.	4-4
4-4. Setting & Releasing Floor Brake.	4-5
4-5. Quick Change Platform Mount.	4-8
4-6. 15AMI Tie Down Pockets.	4-11
5-1. HourMeter Location. (Option)	5-3
5-2. Extendible Platform.	5-5
5-3. PSL™ Switch Location	5-6
5-4. PSL™ Switch Controls & Indicators.	5-6

TABLE OF CONTENTS

SECTION - PARAGRAPH, SUBJECT **PAGE**

LIST OF TABLES

1-1	Minimum Approach Distance (M.A.D.)	1-7
2-1	Inspection and Maintenance Table.	2-3
3-1	15AMI Decal Installation Chart (ANSI)	3-7
3-2	15AMI - Decal Installation (CE - All Languages) . .	3-9
4-1	Maximum Platform Capacity.	4-6
4-2	AMI Machine Gross Weights.	4-10
7-1	Lubrication Specifications.	7-7
7-2	Lubrication Intervals for Various Components . . .	7-9
8-1	Inspection and Repair Log	8-1

SECTION - PARAGRAPH, SUBJECT **PAGE**

SECTION 1. SAFETY PRECAUTIONS

1.1 GENERAL

This section prescribes the proper and safe practices for major areas of machine usage which have been divided into three basic categories: Transporting, Pre-Operation and Operation. In order to promote proper usage of the machine, it is mandatory that a daily routine be established based on instruction given in this section. A maintenance program must also be established by a qualified person and must be followed to ensure that the machine is safe to operate.

The user/operator of the machine should not accept operating responsibility until this manual has been READ and UNDERSTOOD, and operating instructions of the machine under the supervision of an experienced and qualified operator, has been completed. If there is a question on application and/or operation, JLG Industries Product Safety and Reliability Department should be consulted.

WARNING

MODIFICATION OF THE MACHINE WITHOUT APPROVAL OF JLG INDUSTRIES INC., OR CERTIFICATION BY A NATIONALLY RECOGNIZED TESTING LAB TO BE IN CONFORMITY WITH APPLICABLE OSHA REGULATIONS, AND TO BE AT LEAST AS SAFE AS BEFORE MODIFICATION, IS PROHIBITED AND IS A VIOLATION OF OSHA RULES.

SECTION 1 - SAFETY PRECAUTIONS

1.2 TRANSPORTING

Before transporting the machine the user/operator must be familiar with the proper procedures for transporting the machine, as well as the weight and size of the machine.

The user/operator should be familiar with the surrounding work area and surface before transporting the machine. The work area must be a smooth, firm surface on which machine is capable of being leveled.

NOTE: *Remember that the key to safe and proper usage is common sense and its careful application.*

WARNING

FAILURE TO COMPLY WITH SAFETY PRECAUTIONS LISTED IN THIS SECTION AND ON MACHINE MAY RESULT IN MACHINE DAMAGE, PERSONNEL INJURY OR DEATH AND IS A SAFETY VIOLATION.

Transport Safety

- Fully Lower And Completely Empty Platform Of Tools And Debris Before Moving Machine.
- Never Allow Personnel In Platform While Moving Machine.

WARNING

FAILURE TO OBSERVE THE FOLLOWING TIPPING HAZARD INSTRUCTIONS COULD CAUSE THE UNIT TO TIP OVER OR BE HARD TO CONTROL WHEN BEING MOVED, WHICH COULD RESULT IN SERIOUS INJURY OR DEATH DUE TO BEING PINNED OR CRUSHED BY THE UNIT.

- On A Level Surface, Always Travel With The Platform End Leading The Way.
- Watch For Obstructions Around Machine And Overhead When Moving.
- Check Travel Path For Persons, Holes, Bumps, Drop-offs, Obstructions, Debris, And Coverings Which May Conceal Holes And Other Hazards, As Tipping Could Occur.
- Before Moving Machine On Floors, Trucks And Other Surfaces, Check Allowable Capacity Of Surfaces.
- Two People Are Required On Slopes Up To 5 Degrees. A Forklift Must Be Used When Moving Units On Slopes Greater Than 5 Degrees.
- Always Travel Up Or Down A Slope With The Platform End Of The Machine Positioned Towards The Low Side Of The Slope. The Operator And Assistant Must Walk Beside And Guide The Machine With The Handles On The Mast Crossbar.
- Never Position The Unit Sideways On A Slope.



Use Handles Provided On Mast Crossbar To Move Machine.

- Use Caution And Check Clearances When Moving Machine In Restricted Or Close Quarters.
- Always Use An Assistant When Moving Machine In Areas Where Vision Is Obstructed.



Do Not Move Unit on Soft or Uneven Surfaces or Over Obstructions, Bumps, Debris, Etc.

- Keep Non-operating Personnel At Least 6 Feet (1.8 M) Away From Machine During Transporting Operations.

SECTION 1 - SAFETY PRECAUTIONS

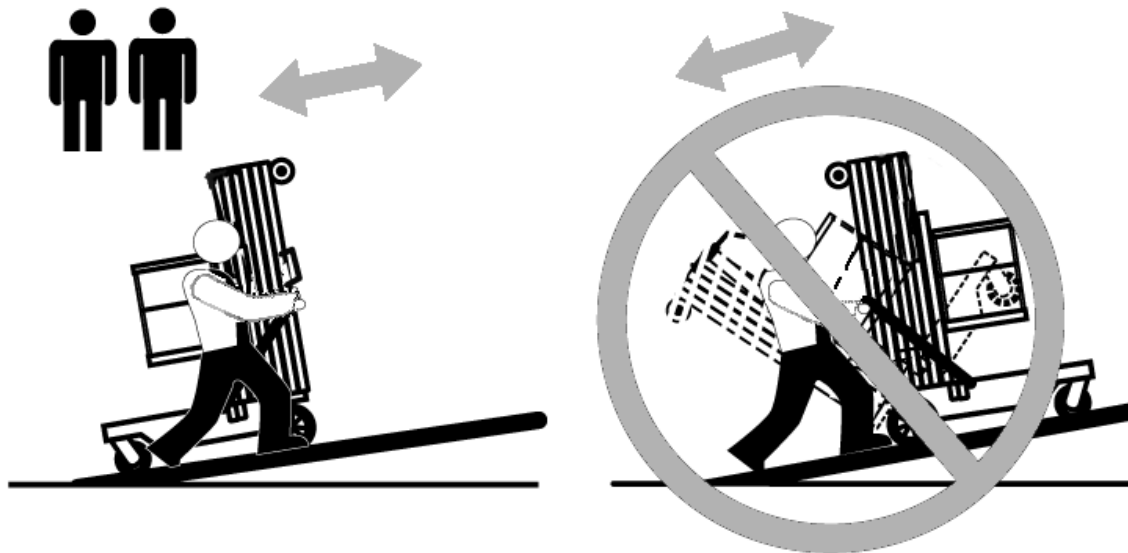

**Two People May Be Required on Slopes Up To Five Degrees.
Also Always Travel With Platform End On The Low Side of Slope.**

1.3 PRE-OPERATIONAL SAFETY

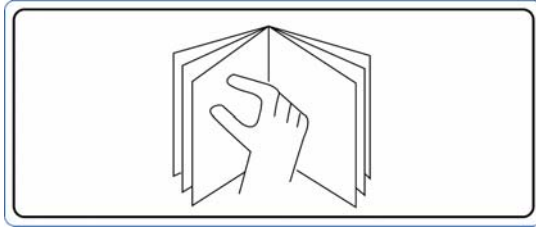

Read Your Manual.

- Read Your Manual. Understand What You've Read - Then Begin Operations.
- Allow Only Those Authorized And Qualified Personnel To Operate Machine Who Have Demonstrated That They Understand Safe And Proper Operation And Maintenance Of The Unit.
- An Operator Must Not Accept Operating Responsibilities Until Adequate Training Has Been Given By Competent And Authorized Persons.
- Before Operation Check Work Area For Overhead Electric Lines. (See *Electrocution Hazard*)
- Before Operation Check Work Area For Machine Traffic Such As Forklifts, Cranes, And Other Construction Equipment.
- Set-up Machine For Operation Only On A Smooth, Firm Level Surface.
- Ensure That Operators Of Other Overhead And Floor Level Machines Are Aware Of The Aerial Platforms Presence. Disconnect Power To Overhead Cranes. Barricade Floor Area If Necessary.
- Precautions To Avoid All Known Hazards In The Work Area Must Be Taken By The Operator And His Supervisor Before Starting The Work.
- Do Not Operate This Machine Unless It Has Been Serviced And Maintained According To The Manufacturers Specifications And Schedule.
- Ensure Daily Inspection And Function Check Is Performed Prior To Placing Machine Into Operation. Have Authorized Personnel Take Any Necessary Corrective Action Before Placing Machine Into Operation.
- Never Disable Or Modify Any Safety Device. Any Modification Of The Machine Is A Safety Violation And Is A Violation Of Osha And Ansi Rules.
- Do Not Operate Machine When Exposed To High Wind, Rain Or Snow.

SECTION 1 - SAFETY PRECAUTIONS

- Never Operate Or Raise Platform When Machine Is On A Truck Or Other Vehicle. Approved Head Gear (I.e. Hard Hat, Etc.) Must Be Worn When Required By All Operating And Ground Personnel.
- Read And Obey All Danger, Warnings, Cautions And Operating Instructions On Machine And In This Manual.
- Be Familiar With Location And Operation Of Ground Station And Emergency Controls.

1.4 OPERATING SAFETY

- Do Not Operate Any Machine On Which Danger, Warning, Caution Or Instruction Placards Or Decals Are Missing Or Illegible.
- Never Exceed Manufacturers Rated Platform Capacity - Refer To Capacity Decal On Machine.
- Operate Ac Units With An Extension Cord Wire Rated At A Minimum Of 15 Amps.
- Do Not Enter Platform Until The Floor Brake Has Been Properly Adjusted And The Unit's Base Frame Is Level According To The Bubble Level Indicator On Base Frame.
- Do Not Operate Machine On Soft Footing That Will Allow The Floor Brake To Settle Into Or Break Through Surface.



**Always Look in the Direction of Movement.
Watch for Overhead and Other Obstructions.**

- Never Operate A Malfunctioning Machine. If A Malfunction Occurs, Shut Down The Machine, Remove It From Service, And Notify Proper Authorities.
- When Applicable By Reason Of Local Regulations Or Job-site/employer Safety Rules, Personnel In The Platform Shall At All Times Wear Approved Fall Protection Devices And Other Safety Gear As Required. A Lanyard Attachment Is Supplied On The Side Of The Machine's Mast.

Electrocution Hazard

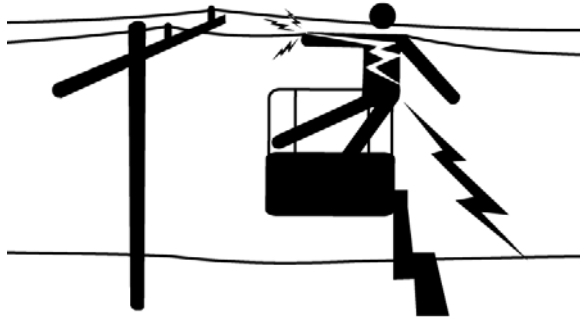

Maintain a clearance of at least 10 ft (3m) between any part of the machine and its occupants, their tools, and their equipment from any electrical line or apparatus carrying up to 50,000 volts. One foot (0.3m) additional clearance is required for every additional 30,000 volts or less.

Table 1-1. Minimum Approach Distance (M.A.D.)

VOLTAGE RANGE (PHASE TO PHASE)	MINIMUM APPROACH DISTANCE - Feet (m)
0-50KV	10 (3)
Over 50KV to 200KV	15 (5)
Over 200KV to 350KV	20 (6)
Over 350KV to 500KV	25 (8)
Over 500KV to 750KV	35 (11)
Over 750KV to 1000KV	45 (14)

NOTE: *This Minimum Approach Distance shall apply except where employer, local, or governmental regulations are more stringent.*

The minimum approach distance may be reduced if insulating barriers are installed to prevent contact, and if the barriers are rated for the voltage of the line being guarded. These barriers shall not be part of (or attached to) the machine. The minimum approach distance shall be reduced to a distance within the designed working dimensions of the insulating barrier. This determination shall be made by a qualified person in accordance with employer, local, or governmental requirements for work practices near energized equipment.

SECTION 1 - SAFETY PRECAUTIONS

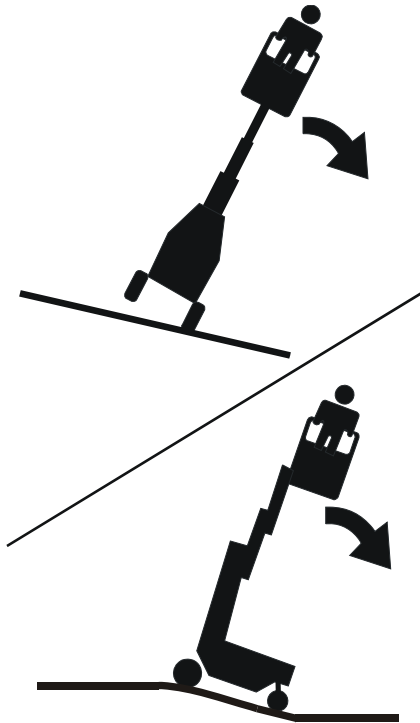

Death or Serious Injury Could Occur from a Tip Over.



All Personnel Must Stand Clear When Platform Is Being Raised Or Lowered.

- Check Clearances Above, On Sides And Bottom Of Platform When Raising And Lowering Platform.
- Never Use The Mast To Gain Access To Or Leave Platform.

- Do Not Attach Overhanging Loads To The Platform Or Increase The Platform Size With Unauthorized Deck Extensions Or Attachments.
- Do Not Tie Off Machine To Any Adjacent Structure. Never Attach Wire, Cable Or Any Similar Items To Platform.
- Transfers Between A Structure And The Platform Expose Operators To Fall Potentials. This Practice Should Be Discouraged Wherever Possible. Where Transfer Must Be Accomplished To Perform The Job, Two Lanyards Will Be Used And The Platform Must Be Within 1 Foot (0.3 M) Of The Adjacent - Safe And Secure - Structure. One Lanyard Should Be Attached To The Platform, The Other To The Structure. The Safety Lanyard That Is Attached To The Platform Should Not Be Disconnected Until Such Time As The Transfer To The Structure Is Complete.
- No Horseplay Is Permitted In Platform.
- Do Not Allow Personnel To Tamper With, Service, Or Operate This Machine From The Ground With Personnel In Platform Except In An Emergency.
- During Platform Operation Keep All Body Parts Inside Platform Railings.
- Never Position Ladders, Steps, Or Similar Items On Unit To Provide Additional Reach For Any Purpose.



**Falling from Platform could cause
Death or Serious Injury.**

- When Working From Platform Both Feet Must Be Firmly Positioned On Deck.
- Do Not Extend Reach Limits Of This Machine With Additional Equipment Such As Planks, Boxes, Etc.

SECTION 1 - SAFETY PRECAUTIONS

- Do Not Use Ladders On Or Against Machine. Do Not Perform Work That Will Subject Unit To A Horizontal Force Or Create A Rocking Motion Of The Platform.
- Do Not Operate Machine From Platform Without The Platform Gate In Place And Properly Closed. This Is A Safety Violation.
- Always Ensure That Power Tools Are Properly Stowed And Never Left Hanging By Their Cord From The Platform Work Area.
- Avoid Accumulation Of Debris On Platform Work Area. Keep Mud, Oil, Grease And Other Slippery Substances From Footwear And Platform Deck.

1.5 MAINTENANCE SAFETY PRECAUTIONS



FAILURE TO COMPLY WITH SAFETY PRECAUTIONS LISTED IN THIS SECTION COULD RESULT IN MACHINE DAMAGE, PERSONNEL INJURY OR DEATH AND IS A SAFETY VIOLATION.

- Remove all rings, watches, and jewelry when performing any maintenance.
- Do not wear long hair unrestrained, or loose fitting clothing and neckties which are apt to become caught on or entangled in equipment.
- Observe and obey all danger, warning, caution and other instructions on machine.
- Keep standing surfaces and hand holds free of oil, grease, water, etc.
- Never work under an elevated platform until platform has been safely restrained from any movement by blocking or overhead sling.
- Before making adjustments, lubricating or performing any other maintenance, shut off all power controls.
- Battery should always be disconnected during replacement of electrical components.
- Keep all support equipment and attachments stowed in their proper place.
- Use only approved, nonflammable cleaning solvents.

SECTION 2. USER RESPONSIBILITIES, MACHINE PREPARATION, AND INSPECTION

2.1 PERSONNEL TRAINING

The aerial platform is a personnel handling device; so it is necessary that it be operated and maintained only by trained personnel.

Persons under the influence of drugs or alcohol or who are subject to seizures, dizziness or loss of physical control must not operate this machine.

Operator Training

Operator training must cover:

1. Use and limitations of the controls in the platform and at the ground, emergency controls and safety systems.
2. Control labels, instructions, and warnings on the machine.
3. Rules of the employer and government regulations.
4. Use of approved fall protection device.
5. Enough knowledge of the mechanical operation of the machine to recognize a malfunction or potential malfunction.

6. The safest means to operate the machine where overhead obstructions, other moving equipment, and obstacles, depressions, holes, dropoffs.
7. Means to avoid the hazards of unprotected electrical conductors.
8. Specific job requirements or machine application.

Training Supervision

Training must be done under the supervision of a qualified person in an open area free of obstructions until the trainee has developed the ability to safely control and operate the machine.

Operator Responsibility

The operator must be instructed that he/she has the responsibility and authority to shut down the machine in case of a malfunction or other unsafe condition of either the machine or the job site.

NOTE: *The Manufacturer or Distributor will provide qualified people for training assistance with the first unit(s) delivered and from that time forward as requested by the user or his/her personnel.*

2.2 PREPARATION, INSPECTION, AND MAINTENANCE

The following table covers the periodic machine inspections and maintenance recommended by JLG Industries, Inc. Consult local regulations for further requirements for aerial work platforms. The frequency of inspections and maintenance must be increased as necessary when the machine is used in a harsh or hostile environment, if the machine is used with increased frequency, or if the machine is used in a severe manner.

NOTICE

JLG INDUSTRIES, INC. RECOGNIZES A FACTORY-CERTIFIED SERVICE TECHNICIAN AS A PERSON WHO HAS SUCCESSFULLY COMPLETED THE JLG SERVICE TRAINING SCHOOL FOR THE SPECIFIC JLG PRODUCT MODEL.

SECTION 2 - USER RESPONSIBILITIES, MACHINE PREPARATION, AND INSPECTION

Table 2-1. Inspection and Maintenance Table

TYPE	FREQUENCY	PRIMARY RESPONSIBILITY	SERVICE QUALIFICATION	REFERENCE
Pre-Start Inspection	Before using each day; or whenever there's an Operator change.	User or Operator	User or Operator	Operator and Safety Manual
Pre-Delivery Inspection <i>(See Note)</i>	Before each sale, lease, or rental delivery.	Owner, Dealer, or User	Qualified JLG Mechanic	Service and Maintenance Manual and applicable JLG inspection form
Frequent Inspection	In service for 3 months or 150 hours, whichever comes first; or Out of service for a period of more than 3 months; or Purchased used.	Owner, Dealer, or User	Qualified JLG Mechanic	Service and Maintenance Manual and applicable JLG inspection form
Annual Machine Inspection	Annually, no later than 13 months from the date of prior inspection.	Owner, Dealer, or User	Factory-Certified Service Technician <i>(Recommended)</i>	Service and Maintenance Manual and applicable JLG inspection form
Preventative Maintenance	At intervals as specified in the Service and Maintenance Manual.	Owner, Dealer, or User	Qualified JLG Mechanic	Service and Maintenance Manual
NOTE: <i>Inspection forms are available from JLG. Use the Service and Maintenance Manual to perform inspections.</i>				

2.3 PRE-START INSPECTION

The Pre-Start Inspection should include each of the following:

1. **Cleanliness** – Check all surfaces for leakage (oil, fuel, or battery fluid) or foreign objects. Report any leakage to the proper maintenance personnel.
2. **Decals and Placards** – Check all for cleanliness and legibility. Make sure none of the decals and placards are missing. Make sure all illegible decals and placards are cleaned or replaced.
3. **Operators and Safety Manuals** – Make sure a copy of the Operator and Safety Manual, EMI Safety Manual (Domestic only), and ANSI Manual of Responsibilities (Domestic only) is enclosed in the weather resistant storage container.
4. **Walk-Around Inspection** – Refer to Figure 2-1. on page 2-7
5. **Battery** – Charge as required.
6. **Fuel** (*Combustion Engine Powered Machines Only*) – Add the proper fuel as necessary.
7. **Hydraulic Oil** – Check the hydraulic oil level. Ensure hydraulic oil is added as required. See Section 7 for hydraulic oil specifications.

8. **Function Check** – Once the “Walk-Around” Inspection is complete, perform a function check of all systems in an area free of overhead and ground level obstructions. Refer to Section 3 for more specific instructions.

WARNING

IF THE MACHINE DOES NOT OPERATE PROPERLY, TURN OFF THE MACHINE IMMEDIATELY! REPORT THE PROBLEM TO THE PROPER MAINTENANCE PERSONNEL. DO NOT OPERATE THE MACHINE UNTIL IT IS DECLARED SAFE FOR OPERATION.

2.4 FUNCTION CHECK

The function check of all systems should be performed in an area free of overhead and ground level obstructions. Perform a function check as follows:

1. Set-up machine for operation, according to instructions in Section 3.
2. Enter platform, raise and lower platform 2 ft. to 3 ft. (.61m to .92 m) several times. Check for smooth elevation and lowering of platform.
3. With platform completely lowered, check hydraulic oil level in reservoir at ground control station. Maintain an oil level to the "Fill to Line" indicator on the side of the reservoir. NEVER USE HYDRAULIC BRAKE FLUID.

2.5 DAILY WALK-AROUND INSPECTION

It is the user/operator's responsibility to inspect the machine before the start of each workday. It is recommended that each user/operator inspect the machine before operation, even if the machine has already been put into service under another user/operator. This Daily Walk-Around Inspection is the preferred method of inspection.

General

Begin the "Walk-Around Inspection" (See Figure 2-1.) at item 1 listed following. Continue around machine checking each item in sequence for the conditions listed in the "Walk-Around Inspection Check list".

WARNING

TO AVOID INJURY DO NOT OPERATE MACHINE UNTIL ALL MALFUNCTIONS HAVE BEEN CORRECTED. USE OF A MALFUNCTIONING MACHINE IS A SAFETY VIOLATION.

TO AVOID POSSIBLE INJURY, BE SURE MACHINE POWER IS "OFF" DURING "WALK-AROUND INSPECTION".

NOTE: *Do not overlook visual inspection of chassis underside. Checking this area often results in discovery of conditions which could cause extensive machine damage.*

SECTION 2 - USER RESPONSIBILITIES, MACHINE PREPARATION, AND INSPECTION

- 1. Wheels and Casters** - Properly secured, wheels and casters turn freely and are properly lubricated. Check for any visible damage.
- 2. Floor Brake** - Properly secured to frame, no visible damage (*cracks, distortion, etc.*) and is functioning properly.
- 3. Base Frame** - No visible damage; components properly secured, no loose wires dangling below base; bubble level in place and functioning properly.
- 4. Battery/Battery Charger Installation** - (*DC Machines*) Proper battery electrolyte level, cables secure, no damage or corrosion.
- 5. Motor/Pump/Reservoir Unit** - All properly secured, no visible damage, no evidence of hydraulic leaks. Check that hydraulic reservoir fluid level is filled to the "Fill to Line" mark on the side of the reservoir.
- 6. Manual Descent Control Valve** - Properly secured, no loose or missing parts, no visible damage.
- 7. Ground Controls** - Key switch operable, no visible damage; placards secure and legible; emergency stop switch, no visible damage and properly set for operation.
- 8. Mast Installation** - Mast sections properly secured, no visible damage to mast sections, no loose or missing parts, slide pads properly secured. Mast chains and cables properly secured, lubricated and undamaged. Sequencing cables properly secured and undamaged. Sheaves and pins are properly secured, have no visible damage, no loose or missing parts and are lubricated.
- 9. Platform Controls** - Up/Down and Function Enable buttons properly secured, no loose or missing parts, no visible damage. Placards secure and legible, emergency shut-off button set for operation. Control markings legible; Operators manual enclosed in manual storage tube.
- 10. Guard Rail Installation** - All railings securely attached, no visible damage, no missing parts; sliding entry bar in proper working order. Platform gate/slide bar working properly, no visible sign of damage (*if so equipped*).
- 11. Platform Assembly** - Secure to mast; no loose or missing parts, no visible damage. Control and power cables, no visible damage; cables properly tensioned and seated in control cable sheaves; control cable sheaves not damaged and rotate freely.

SECTION 2 - USER RESPONSIBILITIES, MACHINE PREPARATION, AND INSPECTION

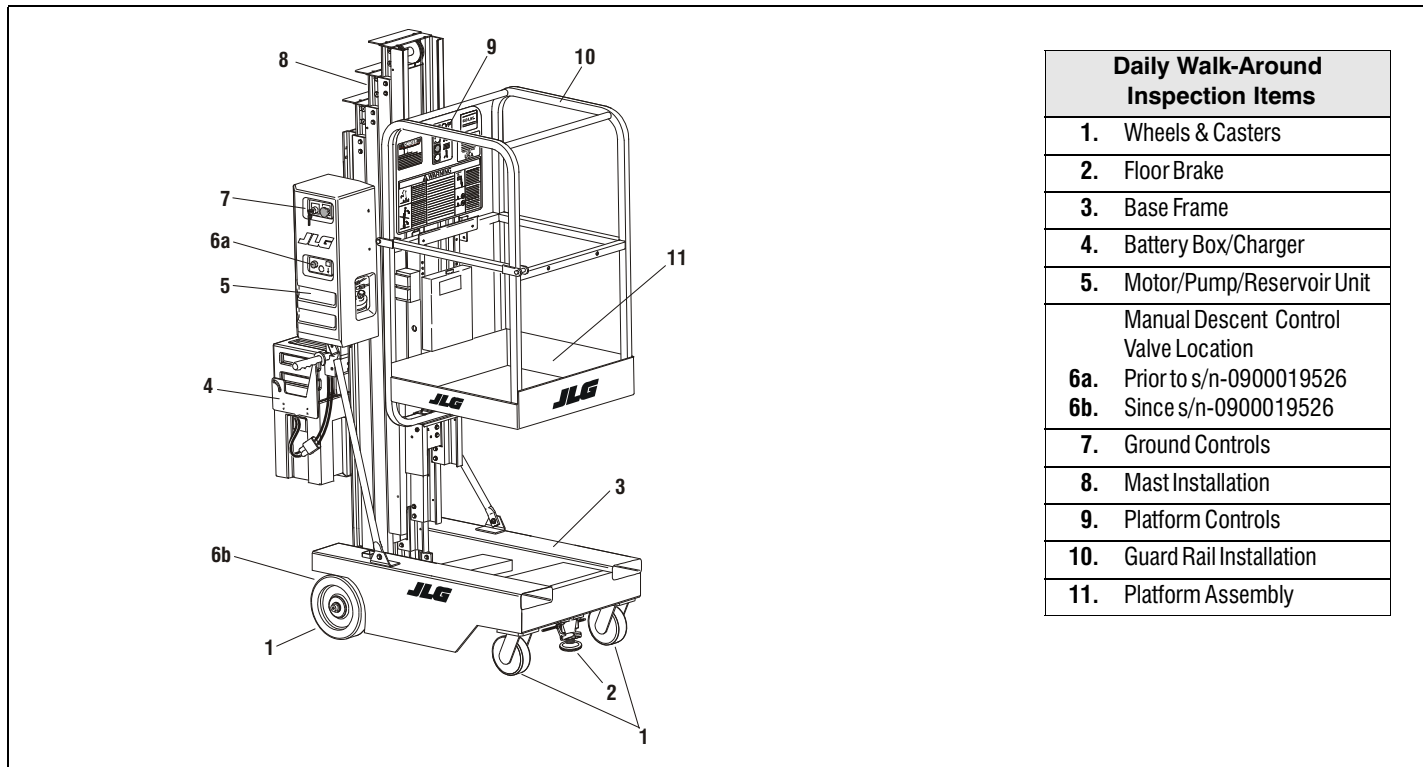

Daily Walk-Around Inspection Items
1. Wheels & Casters
2. Floor Brake
3. Base Frame
4. Battery Box/Charger
5. Motor/Pump/Reservoir Unit
Manual Descent Control Valve Location
6a. Prior to s/n-0900019526
6b. Since s/n-0900019526
7. Ground Controls
8. Mast Installation
9. Platform Controls
10. Guard Rail Installation
11. Platform Assembly

Figure 2-1. Daily Walk-Around Inspection.

SECTION 2 - USER RESPONSIBILITIES, MACHINE PREPARATION, AND INSPECTION



NOTES:

SECTION 3. MACHINE CONTROLS & INDICATORS

3.1 GENERAL

NOTICE

SINCE THE MANUFACTURER HAS NO DIRECT CONTROL OVER MACHINE APPLICATION AND OPERATION, CONFORMANCE WITH GOOD SAFETY PRACTICES IN THESE AREAS IS THE RESPONSIBILITY OF THE USER AND HIS OPERATING PERSONNEL.

This section provides the necessary information needed to understand control functions. Included in this section are the operating characteristics and limitations, and functions and purposes of controls and indicators. It is important that the user/operator read and understand the proper procedures before operating the machine. These procedures will aid in obtaining optimum service life and safe operation.

3.2 CONTROLS AND INDICATORS

Ground Control Station (See Figure 3-1.)

NOTE: *When the machine is shut down for overnight parking or battery charging, be sure the POWER ON/OFF KEY SWITCH is positioned to OFF to prevent draining the batteries.*

1. POWER ON/OFF Key Switch

A key operated power on/off switch located on the ground control station panel controls power to all functions on the unit. The machine will not operate without the key inserted and turned to the ON position. When left unattended removing key will prevent unauthorized machine use.

2. EMERGENCY STOP Button

An emergency stop (*RED button*) is mounted on both the ground control station and the platform control panel. When the button is depressed, all machine functions will stop. To reactivate power to the machine, turn emergency stop button clockwise until button is reset.

SECTION 3 - MACHINE CONTROLS & INDICATORS

3. MANUAL DESCENT CONTROL VALVE

Machines Built Prior to S/N- 0900019526:

(See Figure 3-1.) This (RED knurled) knob, located on the electric/hydraulic pump-motor unit on the ground control station panel provides for lowering of the platform in the event of an emergency or power failure. Turning the valve knob to the left (*counterclockwise*) opens the valve, turning the valve back to the right (*clockwise*) closes the valve.

Machines Built Since S/N- 0900019526 -

(See Figure 3-2.) The control knob is located in the recess under the base frame at the rear of the machine. To open the valve (*lower the platform*) pull the (RED) knob on the control, to close the valve (*stop platform lowering*) release the valve knob (*spring loaded*)

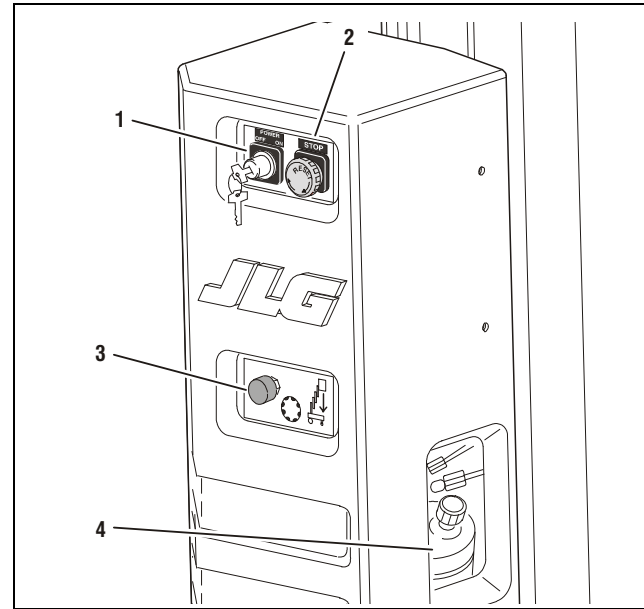

Figure 3-1. Ground Control Station.

- | | |
|----------------------------|-------------------------------------|
| 1. Power On/Off Key Switch | 3. Manual Descent Control Valve (a) |
| 2. Emergency Stop Button | 4. Hydraulic Oil Reservoir |

NOTE: (a) Position of manual descent control valve on machines prior to S/N-0900019526

SECTION 3 - MACHINE CONTROLS & INDICATORS

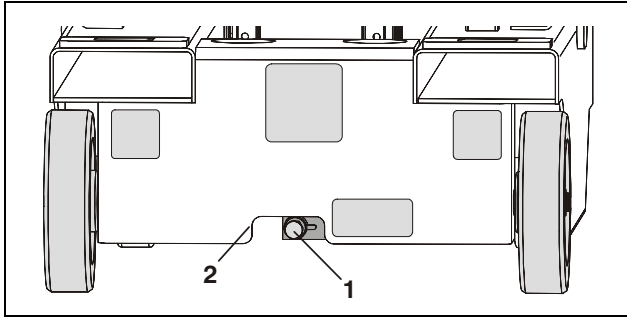

Figure 3-2. Manual Descent Control Valve Location - Machines Built Since S/N- 0900019526.

1. Manual Descent Control Valve
2. Cut-Out at Rear of Base Frame

4. HYDRAULIC RESERVOIR / CIRCUIT BREAKER / FUSE (located inside ground control station housing)

The hydraulic reservoir is housed inside the ground control station, the hydraulic oil level can be checked through an access hole in the side of the cover. Maintain an oil level to the "Fill to Line" indicator on the side of the reservoir.

NOTE: Check hydraulic oil only when platform is completely lowered and after cycling platform up/down a few times.

A 20 amp reset type circuit breaker is located on the cover of the electrical box on AMI-AC Models.

On AMI-DC Models, a 5 Amp fuse is located inside the ground control station.

SECTION 3 - MACHINE CONTROLS & INDICATORS

Platform Control Station

(See Figure 3-3.)

1. EMERGENCY STOP/SHUT-OFF Button.

An EMERGENCY STOP (RED) button is provided in order to turn machine power on and off in the platform and also to turn off machine power in the event of an emergency. Power is on when the switch is in the reset position (*turned completely clockwise - out*). Power is off and all machine functions will stop, when button is depressed.

2. FUNCTION ENABLE Button.

This (GREEN) button must be depressed simultaneously with either the UP or DOWN platform function buttons in order to operate the platform.

3. PLATFORM UP Button.

When depressed simultaneously with ENABLE button raises the platform to a higher level.

4. PLATFORM DOWN Button.

When depressed simultaneously with ENABLE button lowers the platform to a lower level.

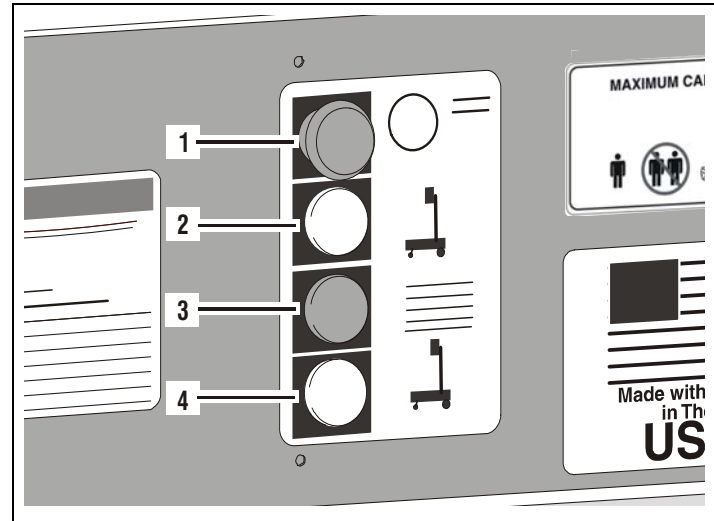

Figure 3-3. Platform Control Station.

- | | |
|-------------------------|----------------------------|
| 1. Emergency Stop (RED) | 3. Function Enable (GREEN) |
| 2. Platform UP (WHITE) | 4. Platform DOWN (WHITE) |



NOTES:

A series of horizontal lines forming a grid for notes, consisting of two columns of ten lines each.

3.3 DECAL INSTALLATIONS

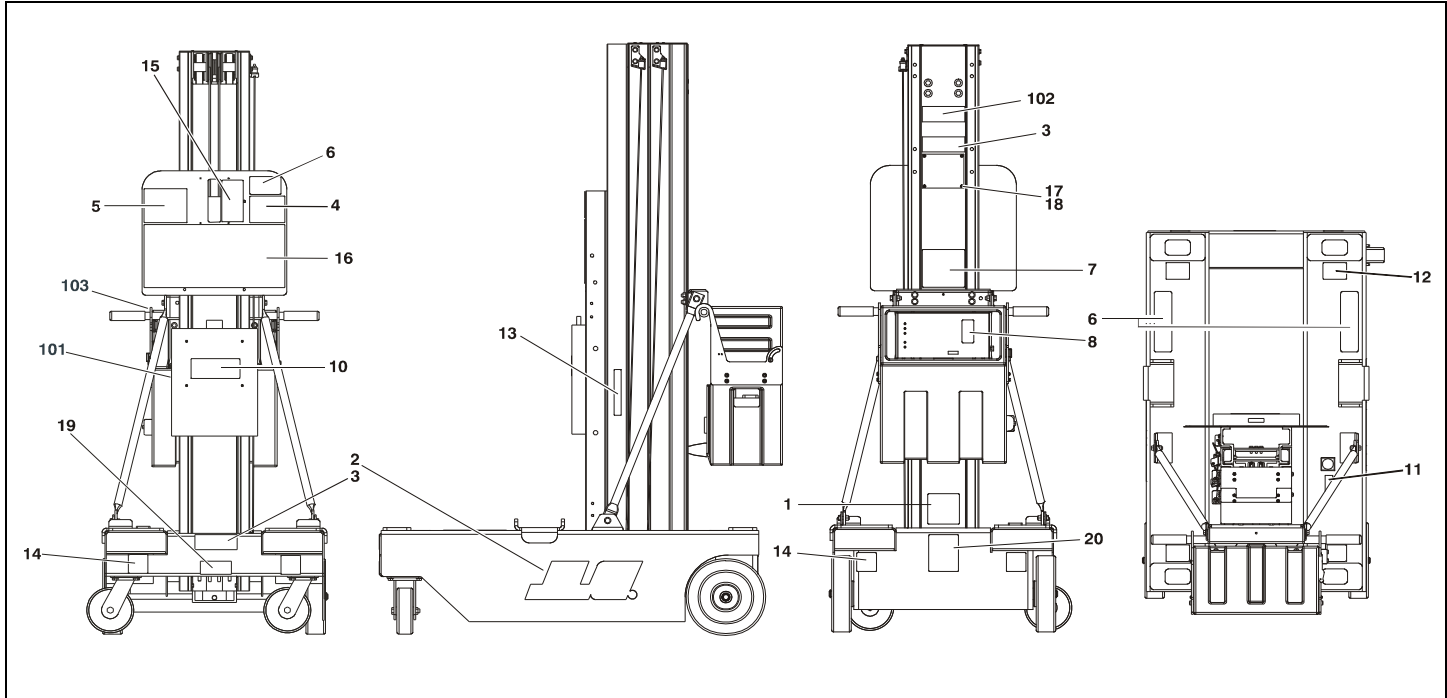

Figure 3-4. Decal Installation. (ANSI and CSA Specification) (See Table 3-1)

SECTION 3 - MACHINE CONTROLS & INDICATORS

Table 3-1. 15AMI Decal Installation Chart (ANSI)
(See Figure 3-4.)

Item	ANSI/CSA	(JPN)	(LAT)	(CHI)
1	—	—	—	—
2	1703625			
3	1703681			
4	1703779	1701509		
5	1703781	1703814		
6	1704259	1703817		
7	1703784	1703844	1703836	1704277
8	1703785	1704086	1704029	1704077
9	1703786	1704088	1704030	1704078
10	1701509	1704089	1704031	1704079
11	1703789	1704090	1704032	1704081
12	1703814	1704092	1704034	1704081
13	1703815	1704215	1704213	1704076
14	1703817	1704224	1704222	1704964
15	1704212	1704290	1704289	1704966
16	1704221	1704346	1704345	1704965
17	1707081	1707080		
18	3820006			

Table 3-1. 15AMI Decal Installation Chart (ANSI)
(See Figure 3-4.)

Item	ANSI/CSA	(JPN)	(LAT)	(CHI)
19	1704244	1700584		
20	1700584	—	—	—
21	1704386	—	—	—
101	3251243 - 120V-60HZ 3251242 - 240V-50HZ			
102	1704190	1704190		
103	1704236	1704209	1704206	1704210

SECTION 3 - MACHINE CONTROLS & INDICATORS

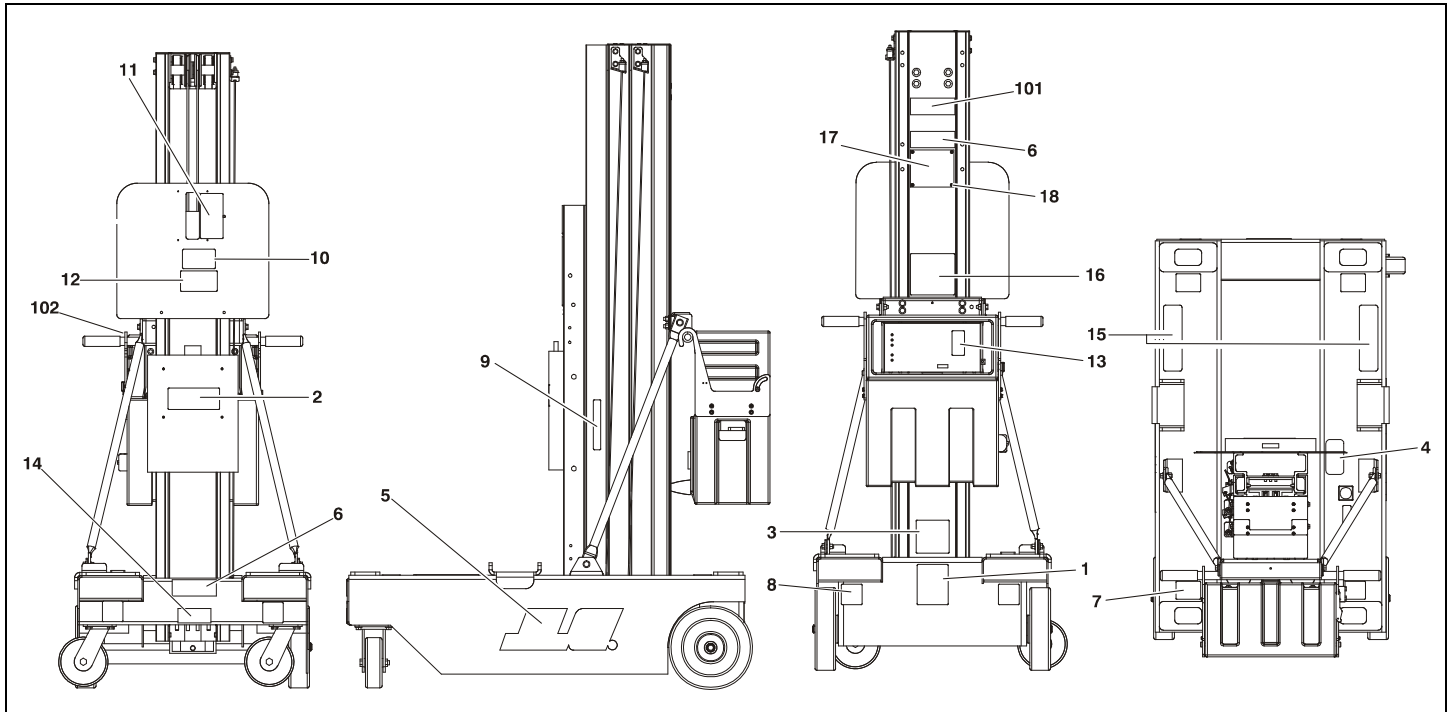

Figure 3-5. Decal Installation. (CE Specification)

SECTION 3 - MACHINE CONTROLS & INDICATORS

Table 3-2. 15AMI - Decal Installation (CE - All Languages)
(See Figure 3-5.)

Item	CE (All Languages)
1	1700584
2	1701509
3	Not Available
4	1702928
5	1703625
6	1703681
7	1703814
8	1703817
9	1704277
10	1704406
11	1705801
12	1705802
13	1705803
14	1705804
15	1705805
16	1705831
17	Not Available

Table 3-2. 15AMI - Decal Installation (CE - All Languages)
(See Figure 3-5.)

Item	CE (All Languages)
18	3820006
101	1704190
102	1704236

SECTION 3 - MACHINE CONTROLS & INDICATORS

 **NOTES:**

<hr/>	<hr/>
<hr/>	<hr/>
<hr/>	<hr/>
<hr/>	<hr/>
<hr/>	<hr/>
<hr/>	<hr/>
<hr/>	<hr/>
<hr/>	<hr/>
<hr/>	<hr/>
<hr/>	<hr/>
<hr/>	<hr/>
<hr/>	<hr/>
<hr/>	<hr/>
<hr/>	<hr/>
<hr/>	<hr/>
<hr/>	<hr/>
<hr/>	<hr/>
<hr/>	<hr/>
<hr/>	<hr/>
<hr/>	<hr/>
<hr/>	<hr/>
<hr/>	<hr/>

SECTION 4. MACHINE OPERATION

4.1 DESCRIPTION

This machine is a manually propelled machine, with a work platform mounted to an elevating aluminum mast mechanism. The personnel lift's intended purpose is to provide personnel (*with their tools and supplies*) access to areas above ground level.

The primary operator control station is in the platform. From this control station, the operator can raise and lower the platform. A ground control station is provided to lower the platform to the ground in an emergency if the operator in the platform is unable to do so, or if a power failure should occur.

Vibrations emitted by these machines are not hazardous to an operator in the work platform. The equivalent continuous A-Weighted sound pressure level at the work platform is less than 70dB(A).

4.2 OPERATING CHARACTERISTICS AND LIMITATIONS

Capacities

The platform can be raised above the stowed position if:

- The machine is positioned on a smooth, firm surface on which the machine is capable of being leveled.
- Load is within manufacturer's rated capacity.
- All machine systems are functioning properly.
- The machine is leveled and outriggers are properly installed as indicated by the outrigger interlock LED lights on the base frame.

4.3 BATTERY CHARGING & MAINTENANCE

AMI Models are equipped with a 12 volt, 10 amp output - dual voltage (120/240V) input battery charger. The charger is micro-processor controlled featuring an automatic charge sensing circuit which can determine cell voltage and regulate charger output and terminate charging as required.

Battery Maintenance and Safety (See Figure 4-1.)

- BATTERY ACID IS HIGHLY CORROSIVE. AVOID CONTACT WITH SKIN AND CLOTHING AT ALL TIMES.
- BATTERY ACID RELEASES AN EXPLOSIVE GAS WHILE CHARGING, ALLOW NO OPEN FLAMES, SPARKS OR LIGHTED TOBACCO PRODUCTS IN THE AREA WHILE CHARGING BATTERIES. CHARGE BATTERIES ONLY IN A WELL VENTILATED AREA.
- ADD ONLY DISTILLED WATER TO BATTERIES. WHEN ADDING DISTILLED WATER TO THE BATTERIES, A NON-METALLIC CONTAINER AND/OR FUNNEL MUST BE USED.

The battery fluid level should be approximately 1/8" (3mm) below vent tubes. (See Figure 4-1.)

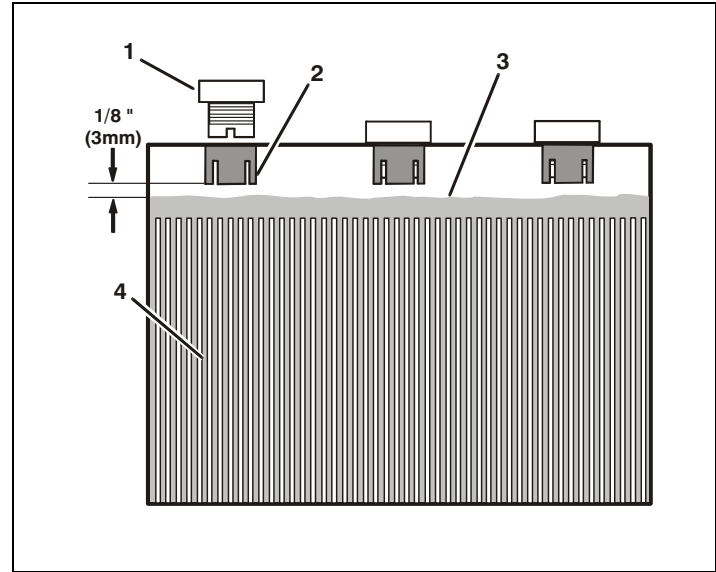

Figure 4-1. Battery Fluid Level.

- | | |
|-----------------------|----------------|
| 1. Battery Filler Cap | 3. Fluid Level |
| 2. Vent Tube | 4. Cell Plates |

Battery Charger Operation (See Figure 4-2. & Figure 4-3.)

NOTICE

ALWAYS CHECK THE VOLTAGE SELECT SWITCH ON THE FACE OF THE BATTERY CHARGER BEFORE OPERATION. IF NOT SET TO THE PROPER AC POWER INPUT VOLTAGE, THE CHARGER MAY BE DAMAGED.

1. Turn the ground control key switch to the OFF position.
2. Set the AC voltage switch on the face of the charger for the local AC line voltage.
3. Plug the battery charger AC power cable, stowed inside the battery/charger carrier (*beside charger*) into a properly grounded receptacle. Use a suitable extension cord, if necessary.
4. The charger runs through a self-diagnostic check. The LED's on the face of the charger flash in the following sequence;
 - a. First all five (5) LED's flash three (3) times.
 - b. Next each LED lights in sequence.
 - c. Finally all five (5) LED's flash three (3) times again.
5. When ready to charge, the CHARGER ON LED and the INCOMPLETE CHARGE (25%) LED on the front panel of

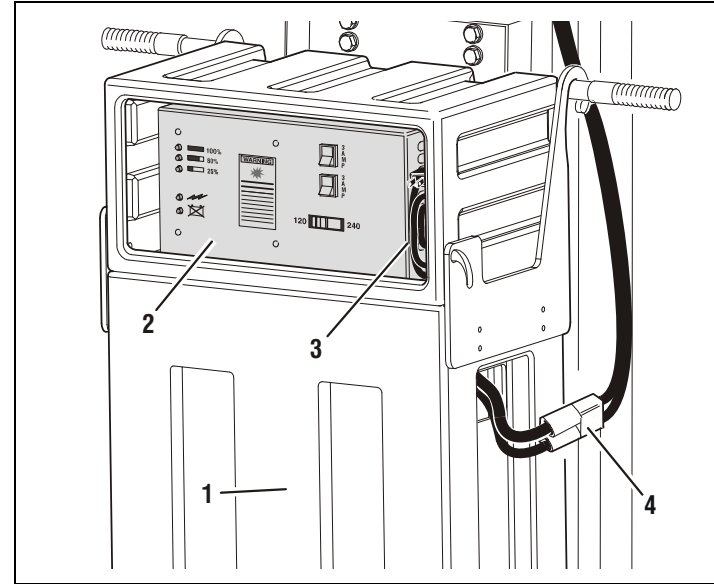

Figure 4-2. Battery Box and Charger Assembly.

- | | |
|---------------------------------|---|
| 1. Battery Box/Charger Assembly | 3. Charger AC Power Cord |
| 2. DC Battery Charger | 4. DC - Battery to Machine Main Power Connector |

SECTION 4 - MACHINE OPERATION

the charger will light up, the charger will then begin to charge the batteries.

- When the battery cell voltage reaches 2.37 V/cell the 80% CHARGE LED will light up. The charger then continues to monitor the increase in charge until it sees no increase, and then terminates the charging process.
- The CHARGE COMPLETE (100%) LED will light when the batteries are fully charged.
- Unplug the charger AC power cord and stow the cord.

Abnormal Cycle Indicator LED

The ABNORMAL CYCLE indicator LED will light when;

- The AC input to the charger was interrupted.
- There is a dead cell or cells in the battery.
- One or more of the battery connectors are loose or corroded.

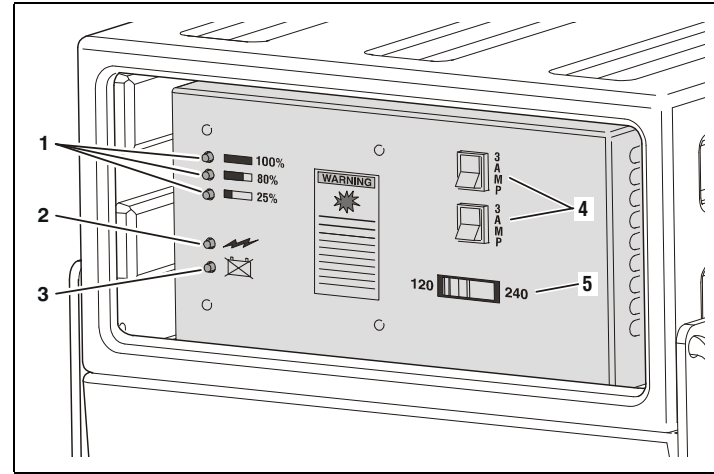

Figure 4-3. Dual Voltage Charger - Front Panel.

- | | |
|--|--------------------------------|
| 1. % of Charge in Progress LED's (Green) | 4. Circuit AC Circuit Breakers |
| 2. Charger On LED (Green) | 5. AC Voltage Selection Switch |
| 3. Abnormal Cycle LED (Yellow) | |

4.4 MACHINE SET-UP AND OPERATION

The following sequence of set-up procedures must be followed to safely operate this machine.

1. Position machine in work area. Work area must be a smooth, firm, level surface.

NOTE: *If AC powered machine, connect machine to a grounded AC receptacle with a heavy duty extension cord equipped with an equipment grounding conductor. Also, the cord must be capable of handling the maximum amperage draw of the machine's electric pump motor.*

If DC powered machine, be sure battery box assembly is installed, battery is charged and connected to the machine's DC input receptacle.

2. Set power on/off key switch to the ON position at the ground control station.
3. Check both emergency stop switches, one on platform control station and one on ground control station that they are in the reset position for operation.
4. Check if manual descent control valve is closed.
5. Set floor brake, see steps following.

Floor Brake Operation

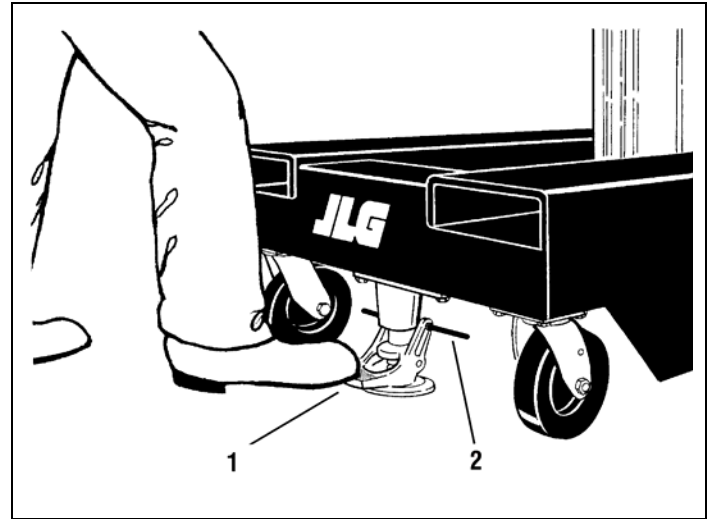

Figure 4-4. Setting & Releasing Floor Brake.

- | | |
|---|---|
| 1. To Set Floor Brake - Push
Down till Pedal Locks in Place. | 2. To Release Floor Brake - Push
Down on Release Rod |
|---|---|

1. At the front of the machine under the base frame, engage and lock the floor brake down into position

WARNING

THE FRONT CASTER WHEELS SHOULD BE RELIEVED OF THE MACHINES WEIGHT ENOUGH SO THE MACHINE DOES NOT ROLL IN ANY DIRECTION. IF THIS IS NOT THE CASE DO NOT ATTEMPT TO ELEVATE THE PLATFORM UNTIL THE FLOOR BRAKE IS OPERATING PROPERLY.

2. To disengage the floor brake, apply pressure to the release rod or lift up on the floor brake pedal.

Platform Loading

The platform maximum rated load capacity is shown on a placard located on the platform control panel and is based upon the following criteria.

Maximum capacity for each model is as follows:

Table 4-1. Maximum Platform Capacity.

MODEL	PLATFORM CAPACITY	
	(All Platforms Except Extendible)	Extendible Platform (Option)
15AMI-AC/DC	350 lb.(160 kg)	300 lb. (135 kg)

Platform Operation

WARNING

DO NOT ATTEMPT TO RAISE THE PLATFORM UNLESS THE FLOOR BRAKE IS PROPERLY SET AND MACHINE IS ON A SMOOTH, FIRM, LEVEL SURFACE.

BEFORE AND WHILE RAISING THE PLATFORM, CHECK CLEARANCES ABOVE AND AROUND PLATFORM AND MAST TO ENSURE ADEQUATE CLEARANCE OF SURROUNDING OBJECTS AND PERSONNEL.

1. Enter platform and close the gate/slide bar.

NOTE: *On platform control box the FUNCTION ENABLE (green button) must be depressed simultaneously with either the PLATFORM UP or PLATFORM DOWN button in order for these functions to work.*

2. To raise the platform up, depress the FUNCTION ENABLE BUTTON (green) and PLATFORM UP button (top, white button) on the platform control panel simultaneously. Upon reaching desired elevation level release PLATFORM UP and FUNCTION ENABLE buttons.

WARNING

ENSURE AREA BENEATH PLATFORM IS FREE OF PERSONNEL AND OBSTRUCTIONS PRIOR TO LOWERING PLATFORM.

3. To lower platform, depress FUNCTION ENABLE BUTTON (*green*) and PLATFORM DOWN button (*bottom, white button*) on control panel simultaneously. Upon reaching desired elevation level release PLATFORM DOWN and FUNCTION ENABLE buttons.

4.5 QUICK-CHANGE PLATFORM

The AMI model is equipped with quick-change platform mounts which will allow quick removal and installation of the currently available quick-change platforms. The following procedures describe platform removal and installation:

Platform Removal

1. Remove both lower mount pins securing the **lower** platform support rail to the platform lower mount.
2. Remove both upper mount pins securing the **upper** platform support rail to the platform upper mount.
3. Using either suitable lifting equipment capable of lifting the weight of the mounted platform, or another person, swing the lower platform support rail forward, away from the mast to clear the platform lower mount, then lift the upper platform support rail up and out of the platform upper mount. Move the platform clear of the machine and carefully set the platform on its base out of the way.

Platform Installation

1. Using either two people or suitable lifting equipment capable of lifting the weight of the unmounted platform, lift the platform and set the platforms' upper support rail into the upper platform mount on the mast.

SECTION 4 - MACHINE OPERATION

2. Swing the platform lower support rail into the lower platform mount on the mast.
3. Secure the platform support rails with the two (2) platform upper mount pins, and the two (2) lower platform mount pins.

The platform is now ready for operation.

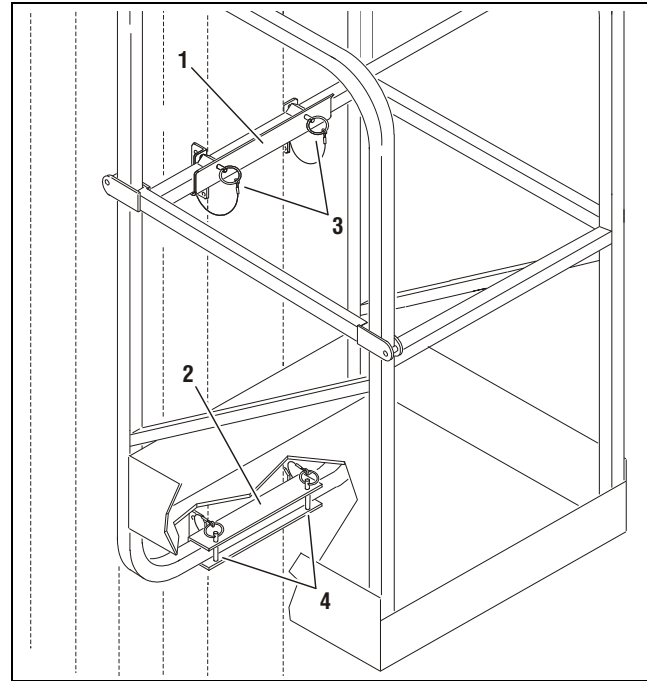

Figure 4-5. Quick Change Platform Mount.

- | | |
|-------------------------|---------------------|
| 1. Platform Upper Mount | 3. Upper Mount Pins |
| 2. Platform Lower mount | 4. Lower Mount Pins |

4.6 STOWING MACHINE

1. Ensure that platform is fully lowered, turn POWER ON/OFF key switch (*on the Ground Control Station*) to the OFF position.

NOTICE

WHEN MOVING MACHINE PLEASE FOLLOW ALL SAFETY PRECAUTIONS DESCRIBED IN SECTION 1, "TRANSPORTING" OF THIS MANUAL. ALSO SEE SECTION 4, "TRANSPORTING, LIFTING AND TIE DOWN" FOR PROPER PROCEDURES FOR TRANSPORTING.

2. Move machine to a well-protected and well-ventilated area. If necessary, cover the machine so it will be protected if in a hostile environment.
3. Set the floor brake when parking machine for an extended period of time.
4. If necessary remove key from Ground Control Panel POWER ON/OFF key switch to disable machine from unauthorized use.

NOTE: *If required, DC machine batteries should be charged in preparation for next work day in accordance with Section 4.3, Battery Charging & Maintenance.*

4.7 TRANSPORTING, LIFTING AND TIE DOWN

General

The AMI machine may be transported from worksite to worksite using any of the following methods:

- Pushing the machine around on its base wheels.
- Transport with a forklift truck using the forklift pockets in the baseframe or to lift onto a transport vehicle.

Transporting by Pushing

NOTICE

CAREFULLY REVIEW ALL SAFETY PRECAUTIONS NOTED IN SECTION 1, "TRANSPORTING", BEFORE ATTEMPTING TO MOVE MACHINE.

The 15AMI machine's base frame is equipped with load bearing wheels mounted on a straight axle at the mast end of the machine; and a pair of heavy duty swivel caster wheels mounted on the frame at the platform end of the machine. It is important to closely follow the instructions mentioned in the following WARNING note to ensure safe transport of unit when pushing.

SECTION 4 - MACHINE OPERATION

⚠ WARNING

FAILURE TO HEED THE FOLLOWING INSTRUCTIONS COULD CAUSE THE UNIT TO TIP OVER OR BE HARD TO CONTROL WHEN BEING MOVED WHICH COULD RESULT IN SERIOUS INJURY OR DEATH DUE TO BEING PINNED OR CRUSHED BY UNIT.

- WALK BEHIND THE UNIT TO PUSH AND STEER USING THE HANDLES ON THE MAST CROSSBAR.
- ON A LEVEL SURFACE, ALWAYS TRAVEL WITH THE PLATFORM END LEADING THE WAY.
- ON A SLOPE, ALWAYS TRAVEL WITH THE PLATFORM END ON THE LOW SIDE OF THE SLOPE.
- TWO PEOPLE ARE REQUIRED ON SLOPES UP TO 5 DEGREES, A FORKLIFT MUST BE USED WHEN MOVING UNITS ON SLOPES GREATER THAN 5 DEGREES.
- NEVER POSITION THE UNIT SIDEWAYS ON A SLOPE.
- DO NOT MOVE UNIT ON SOFT OR UNEVEN SURFACES, OR OVER OBSTRUCTIONS, BUMPS, DEBRIS, ETC.

NOTICE

BEFORE MOVING A MACHINE BY PUSHING, SECURE ANY TOOLS OR OBJECTS WHICH MAY OTHERWISE FALL OFF AND CAUSE INJURY OR BE DAMAGED DURING TRANSPORT.

Lifting

If it becomes necessary to lift the machine, use suitable lifting equipment capable of handling the weight of the machine, see below.

NOTE: Fork lifts, cranes, chains, slings, etc. must be capable of handling the following weights:

Table 4-2. AMI Machine Gross Weights

AM Model	Gross Weight
15AMI-AC	900 lb. (408 kg)
15AMI-DC	970 lb. (440 kg)

NOTE: All AMI models are equipped with forklift pockets at the mast end of the frame for transporting the unit. An optional crane hook is available. Do not attempt to lift with a crane without the optional crane hook.

Transport Vehicle Tie Down

(See Figure 4-6.)

When placing the 15AMI machine onto a transport vehicle for transport to another worksite, always tie machine securely to the transport vehicle using the tie down pockets provided on the machine. There are four tie down pockets, one on each corner of the machine. There are also two cross strap saddles at the center on each side of the base frame. Use corner tie down pockets and cross strap saddles as needed. Tie down method shown is for illustrative purposes only.

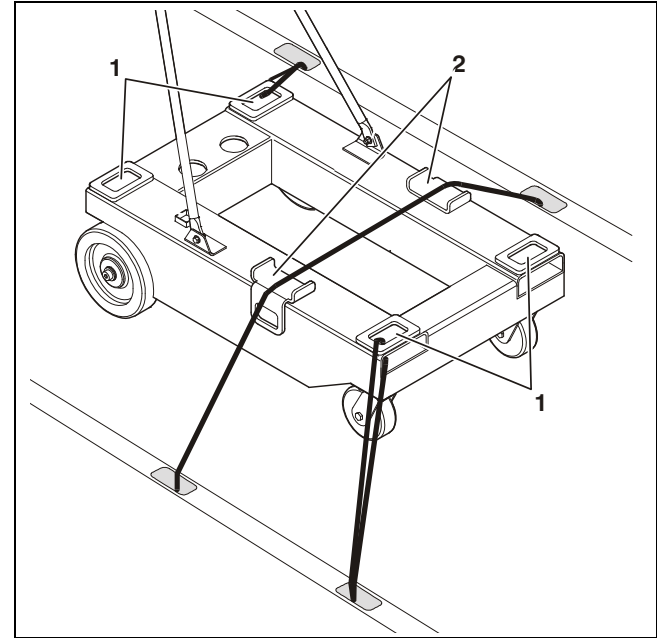

Figure 4-6. 15AMI Tie Down Pockets.

1. Corner Tie-Down Pockets 2. Cross Strap Saddles

SECTION 4 - MACHINE OPERATION



NOTES:

SECTION 5. OPTIONAL EQUIPMENT

5.1 OPTIONAL EQUIPMENT

The following optional equipment is available for AMI models:

22" x 25" Quick-Change Platform

The 25" long by 22" wide platform features a gull wing gate opening and is attached to the mast using the quick- change mount.

26" x 26" Quick-Change Platform

The 26" long by 26" wide platform features a side entry gate opening and is attached to the mast using the quick-change mount.

28" x 26" Quick-Change Platform

The 28" long by 22" wide platform features a gull wing gate opening and is attached to the mast using the quick- change mount.

25" x 26" Step-in Molded Platform w/Swing-up Gate

The 25" long by 26" wide Step-in Molded Platform features a tough molded shell base and sides mounted to a welded steel

frame. This step-in platform features a swing-up gate for easy entry.

26" x 50" Quick-Change - ExtendiblePlatform

(See Section 5-2, Extendible Platform Operation)

The 26" long x 50" wide extendible platform features a gull wing gate and is attached to the mast using the quick change mount.

Tool Tray

The tool tray is attached to the top rail of the platform allowing for quick access to hand tools or other small items placed in the tray.

Fluorescent Tube Caddy

The fluorescent tube caddy is attached to the top rail of the platform allowing for convenient handling when replacing fluorescent tubes.

Extra Power Pack (DC Battery, Charger & Case)

An extra power pack which includes the battery, charger and molded case allows for extended use of an AM machine under high cycle conditions. One power pack can be charging while the other is in use.

SECTION 5 - OPTIONAL EQUIPMENT

Lifting Hook

The optional lifting hook is mounted at the top rear of the first mast section. The hook is used to lift the machine up or down to another level.

Platform Auxiliary Power Lowering Device

The Platform Auxiliary Power Lowering device is a switch activated battery backed electrical circuit designed to provide power to the platform control box in the event of loss of the machines power supply. This can be useful to the operator if the main battery on a DC model becomes depleted or the AC power supply of an AC model is interrupted while the platform is raised. Also if the on/off key switch on the ground control station is turned to the off position while the platform is still raised.

Laser Positioning Device

The laser positioning device attaches to the platform railing and when powered on projects a laser dot on any surface above the machine. This allows the operator to more accurately position the machine under a work area before raising the platform in position.

Locking Swivel Caster Wheels

Machines equipped with this option allow the operator to lock the front swivel caster wheels into position parallel with the base

frame when pushing the machine to a work area or during machine operation.

Programmable Security Lock

(See Section 5.3, Programmable Security Lock (PSL™) (Option)

The optional keyless Programmable Security Lock switch can be programmed with a four (4) digit operators code to allow only those persons with the code to power-up and operate the machine

Descent Alarm

The descent alarm option will activate when the platform is being lowered from a raised position to alert ground personnel of platform movement. The descent alarm can be combined with the descent warning strobe.

Descent Warning Strobe

The warning strobe option will activate when the platform is being lowered from a raised position to alert ground personnel of platform movement. The strobe is mounted to the base frame under the platform, the strobe can be seen from any position in a 360° circle.

Hourmeter

(See Figure 5-1., HourMeter Location. (Option))

The machine hourmeter accumulates pump operation time during the platform LIFT UP cycle only. The reading indicates hours and tenths of an hour.

Machine Cycle Counter Meter

The Cycle Counter Meter is located on the front side of the Ground Control Station. This meter tracks the number of cycles the mast travels up and down during machine operation. This information can be used to determine maintenance intervals and other for other informational purposes when recorded over a specific period of time.

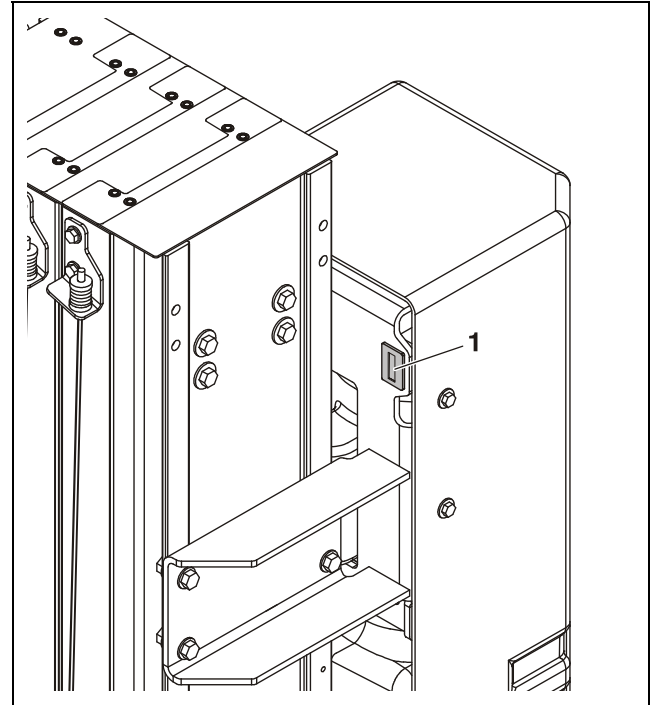

Figure 5-1. HourMeter Location. (Option)

1. HourMeter

5.2 EXTENDIBLE PLATFORM OPERATION

The optional extendible platform is designed to increase operator reach over the front of the machine, this allows the operator access to work areas which may otherwise be unreachable from the standard platform. The following procedures describe proper use of the Extendible Platform.

Mounting to Mast

The Extendible Platform mounts using the same quick-mount hardware as the standard platform, see Section 4, Quick-Change Platform, in this manual for procedures to mount and remove the platform on the mast.

Once the platform is mounted re-check that all mounting pins on upper and lower platform mast mounts, two (2) pins on upper mount and two (2) pins on lower mount are installed and secure.

Entering/Exiting Platform

(Refer to Figure 5-2.)

The Extendible Platform is equipped with a swing-up gullwing gate for entrance into the platform.



WARNING

THE TOTAL WEIGHT CAPACITY FOR THE EXTENDIBLE PLATFORM ASSEMBLY IS 300 LB. (135 KG) (ANSI/CE)

To ENTER the platform:

1. Raise the swing up gate by grasping the front mid rail with one hand and pull up on the gate lock-pin release cable on the front of the platform assembly.
2. Next lift the gate high enough to enter the platform. Step into the platform, when completely inside platform, lower the gate until it's closed and the gate lock-pin is engaged and locked.

To EXIT platform:

1. Repeat the above steps and exit the platform.

Extending Platform

(Refer to Figure 5-2.)

1. Locate the two platform extend handles (1), one located each side of platform on the vertical rails at the back of the platform (2).
2. Grasp each extend handle and pull the handle (1) up to a horizontal position releasing it from the spring clamp. Face the mast (4) and pull the extend handles to extend the platform extension forward away from mast (5).
3. Slide the platform extension forward until it's completely extended (5), and the extend handles line up with the spring clamps on the vertical rail at the opposite end of the platform (1).

4. Next fold the extend handles down until they lock into the spring clamps on the vertical rail (1), this will lock the platform extension in place.

Retracting Platform

(Refer to Figure 5-2.)

1. To retract the platform grasp the extend handles now located at the middle of the extended platform on the vertical rail (1). Pull up on each handle to a horizontal position to clear the handle spring clamps.
2. Retract the platform extension by standing on the rear (mast) platform section and pulling the extend handles (1) toward the mast (4), (you may need to pull the handles halfway then turn and push them the rest of the way to fully retract the platform extension).
3. When both extend handles line up with the handle spring clamps (2) on the vertical rail at the rear of the platform, fold the handles (1) down locking them into the spring clamps (2).

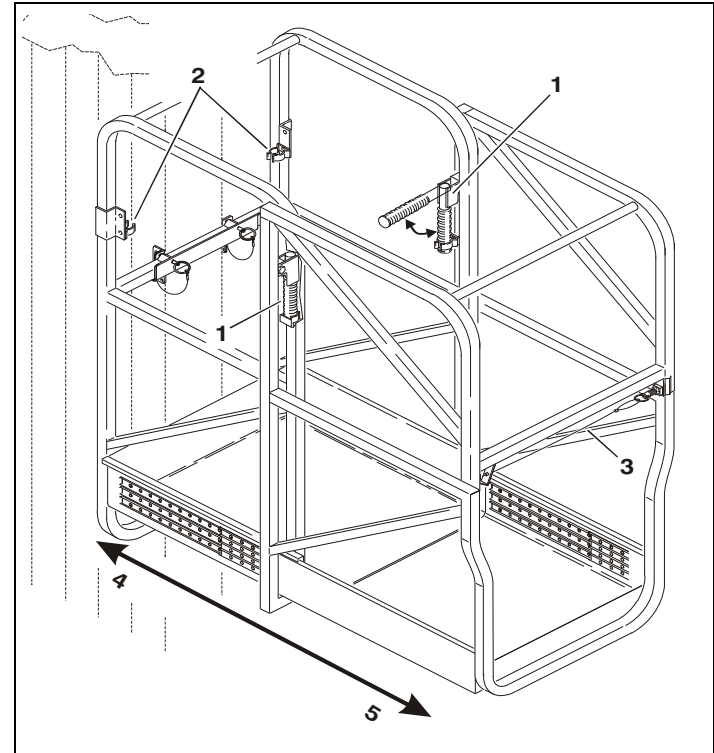

Figure 5-2. Extendible Platform.

5.3 Programmable Security Lock (PSL™) (Option)

The optional keyless Programmable Security Lock switch can be programmed with a four (4) digit operators code to allow only those persons with the code to power-up and operate the machine.

PSL™ Box Location

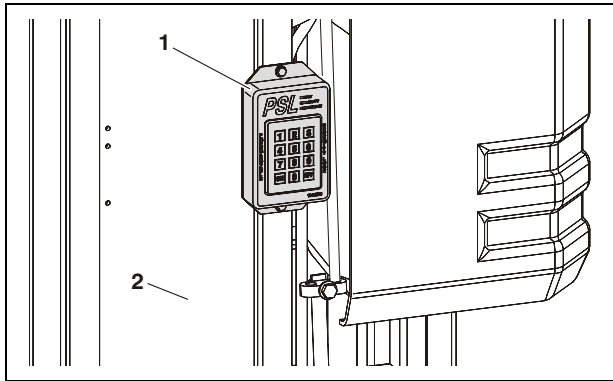

Figure 5-3. PSL™ Switch Location

- 1. PSL Switch
- 2. Back of Mast Assembly

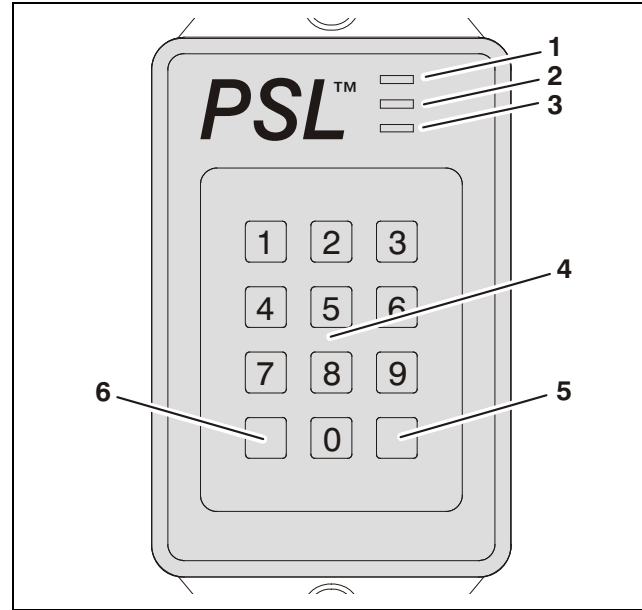

Figure 5-4. PSL™ Switch Controls & Indicators.

- 1. ON (Green LED)
- 2. ACCEPT (Amber LED)
- 3. PROGRAM (Red LED)
- 4. Key Pad
- 5. OFF Button
- 6. ON Button

Machine Power Up using the PSL™

NOTE: *When entering code on the keypad, a short beep indicates a properly depressed key, a long beep indicates an error in depressing key. If an error occurs, you must restart the code entry process again.*

1. Enter the four digit code on the PSL key pad. The ACCEPT - AMBER LED indicator will be lit if the code is correct.
2. Press the keypad ON button. The ON - GREEN LED indicator will light and power will be supplied to the Ground Control Station.
3. At the ground control station, turn the main power selector switch from OFF to ON.
4. The machine will now operate normally.

Machine Power Down

1. At the Ground Control Station set the main power selector switch to the OFF position.
2. Press the OFF button on the PSL keypad. No LEDs on the PSL box will be lit.

Changing the Operator's Code

The PSL Operators Code can be changed by a supervisor should the need occur. A separate permanent Supervisor's Code matched to the serial number of the PSL box is included on a sheet in the PSL user manual supplied with the machine.

1. Enter the Supervisor's code on the key pad. The PROGRAM - RED LED will be lit if correct code is entered.

NOTE: *The ON or OFF button cannot be one of the four digits of the Operator's code.*

2. Enter a new four (4) digit Operator's code on the keypad. The ACCEPT - AMBER LED will light up if the new Operator's code is accepted.
3. Press the OFF button on the keypad to activate the new Operator's code.

NOTE: *The new Operator's code will remain in the PSL even when power is removed from the equipment, or until the Supervisor changes the Operator's code.*

SECTION 5 - OPTIONAL EQUIPMENT



NOTES:

<hr/> <hr/> <hr/> <hr/> <hr/> <hr/> <hr/> <hr/> <hr/> <hr/> <hr/> <hr/> <hr/> <hr/> <hr/>	<hr/> <hr/> <hr/> <hr/> <hr/> <hr/> <hr/> <hr/> <hr/> <hr/> <hr/> <hr/> <hr/> <hr/> <hr/>
---	---

SECTION 6. EMERGENCY PROCEDURES

6.1 General Information

This section explains the steps to be taken in case of an emergency situation while operating the machine.

6.2 Emergency Operation

Operator Unable to Control Machine

IF THE PLATFORM OPERATOR IS PINNED, TRAPPED OR UNABLE TO OPERATE OR CONTROL THE MACHINE, USE THE FOLLOWING INSTRUCTIONS AS A GUIDELINE.

1. Other personnel should operate the machine from ground controls only as required.
2. Only qualified personnel in the platform may use the platform controls. DO NOT CONTINUE OPERATION IF CONTROLS DO NOT FUNCTION PROPERLY.
3. Cranes, forklift trucks or other equipment can be used to remove the platform occupant and stabilize motion of the machine.

Platform Caught Overhead

If the platform becomes jammed or snagged in overhead structures or equipment, rescue the platform occupant prior to freeing the machine.

Righting of Tipped Machine

Before righting a tipped machine, check machine for any damage which may prevent it from setting properly on its base wheels once in a vertical position, (i.e. base wheels damaged, base frame distorted, etc.). Use a crane, forklift or other suitable lifting equipment and carefully lift the machine to an upright position.

NOTICE

FOLLOWING ANY INCIDENT, THOROUGHLY INSPECT THE MACHINE AND TEST ALL FUNCTIONS. DO NOT LIFT ABOVE 10 FEET (3 METERS) UNTIL YOU ARE SURE THAT ALL DAMAGE HAS BEEN REPAIRED, IF REQUIRED, AND THAT ALL CONTROLS ARE OPERATING CORRECTLY.

SECTION 6 - EMERGENCY PROCEDURES

6.3 Incident Notification

JLG Industries, Inc. must be notified immediately of any incident involving a JLG product. Even if no injury or property damage is evident, the factory should be contacted by telephone and provided with all necessary details.

JLG Phone:

USA: 877-JLG-SAFE (554-7233)
(8am till 4:45pm EST)

EURO: 011 44 1 698 811005

AUSTRALIA: 011 61 2 65 811111

Email (USA): productsafety@jlg.com

Failure to notify the Manufacturer of an incident involving a JLG Industries product within 48 hours of such an occurrence may void any warranty consideration on that particular machine.

SECTION 7. GENERAL SPECIFICATIONS AND OPERATOR MAINTENANCE

7.1 INTRODUCTION

This section of the manual provides additional necessary information to the operator for proper operation and maintenance of this machine.

The maintenance portion of this section is intended as information to assist the machine operator to perform daily maintenance tasks only, and does not replace the more thorough Preventive Maintenance and Inspection Schedule included in the Service and Maintenance Manual.

OTHER PUBLICATIONS AVAILABLE SPECIFIC TO THIS MACHINE

Service And Maintenance Manual	Illustrated Parts Manual
ANSI 3120752	ANSI 3120753
CE 3120872	CE 3120873

7.2 GENERAL SPECIFICATIONS

Machine Specifications

SPECIFICATION	15AMI
Gross Machine Weight (<i>Platform Empty</i>): DC:	970 lb. (440 kg)
AC:	900 lb. (408 kg)
Machine Height (<i>Platform Stowed</i>)	78.25 in. (1.9 m)
Machine Base - Overall: (<i>Width x Length</i>)	29 in.(W) x 47 in.(L) (74 cm x 119 cm)
Maximum Wind Speed:	0 mph (0kph) - Machine rated for indoor use only
Maximum Horizontal Manual Side Force: (<i>Platform fully extended with Maximum load</i>)	45 Pound Force (200 Newtons)
Maximum Hydraulic System Pressure:	Pressure Relief Set at 1500 to 1700PSI (193 bar) at Factory

SECTION 7 - GENERAL SPECIFICATIONS AND OPERATOR MAINTENANCE

Electrical Specifications

SPECIFICATION		15AMI	
System Voltage:	DC Models:	12 Volts DC	
	AC Models:	100/120/240 Volts AC	
Battery Specifications: <i>(applies to all DC models)</i>			
	Battery Type	WET/DRY COMBO	AGM (VRLA)
	Voltage	12 Volts DC	
	Amp Hour (AH) Rating	105 AmpHr. @ 20 Hr.	100 AmpHr. @ 20 Hr.
	Reserve Capacity	165 Min.	N/A
	Cold Cranking Amps	625 Amps @ 0° F	N/A
	Weight	54 lb. (24kg)	78 lb. (35kg)
Battery Charger <i>(DC Models)</i>	Input:	120/240 Volts AC - 50/60 Hz - Voltage Selectable	
	Output:	12 Volt - 10 Amps DC - w/Auto Charge Sensing Circuit	

SECTION 7 - GENERAL SPECIFICATIONS AND OPERATOR MAINTENANCE

Platform Data

SPECIFICATION	15AMI
Occupants: <i>(Persons allowed in Platform)</i>	1
Platform Capacity : <i>(All Platforms Except Extendible)</i> ANSI/CE:	350 lb. (160 kg)
Extendible Platform Capacity: ANSI/CE:	300 lb. (135 kg)
Platform Height - Mast Fully Extended - <i>(Ground to Platform Floor):</i>	15 ft. (4.57 m)
Platform Working Height: <i>(Average Size Person)</i>	21 ft. (6.4 m)
Platform Cycle Performance: (in seconds) Lift Up:	30
<i>(w/max. rated load)</i> Lift Down:	22-28

Machine Component Weights

SPECIFICATION		15AMI
Platform Weight :	Standard Platform:	55 lb. (25 kg)
<i>(Quick-Change Platforms)</i>	Molded Platform:	70 lb. (32 kg)
DC Voltage Battery Pack: <i>(Wet Cell)</i>		70 lb. (32 kg)

Serial Number Locations

For machine identification, a serial number plate is affixed to the machine. The plate is located on the back of the mast, just above the mast support bracket.

7.3 OPERATOR MAINTENANCE

Battery Maintenance

NOTE: This information applies to wet cell batteries only. Do not attempt to open a maintenance-free sealed battery.

The battery fluid level should be approximately 1/8" (3mm) below vent tubes. (See Illustration)

Keep cable connections clean and free of corrosion.

⚠ CAUTION

BATTERY ACID IS HIGHLY CORROSIVE. AVOID CONTACT WITH SKIN AND CLOTHING AT ALL TIMES.

BATTERY ACID RELEASES AN EXPLOSIVE GAS WHILE CHARGING, ALLOW NO OPEN FLAMES, SPARKS OR LIGHTED TOBACCO PRODUCTS IN THE AREA WHILE CHARGING BATTERIES. CHARGE BATTERIES ONLY IN A WELL VENTILATED AREA.

ADD ONLY DISTILLED WATER TO BATTERIES. WHEN ADDING DISTILLED WATER TO THE BATTERIES, A NON-METALLIC CONTAINER AND/OR FUNNEL MUST BE USED.

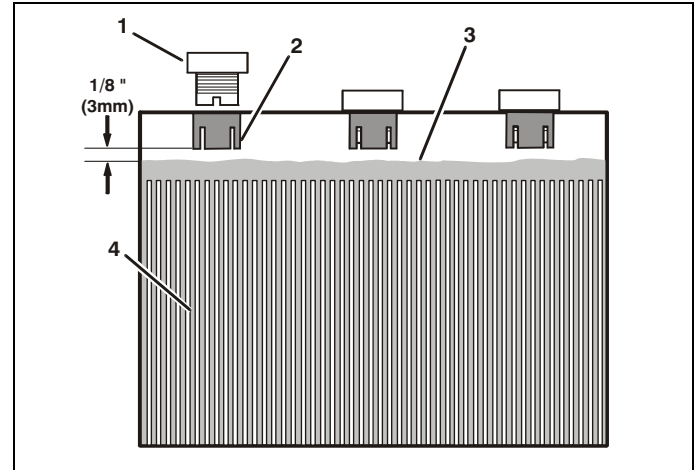

Battery Fluid Level

- 1. Battery Filler Cap
- 2. Vent Tube
- 3. Fluid Level
- 4. Cell Plates

SECTION 7 - GENERAL SPECIFICATIONS AND OPERATOR MAINTENANCE

Lubrication

Table 7-1. - Lubrication Specifications

KEY	SPECIFICATIONS
MPG -	Multipurpose Grease having a minimum dripping point of 350° F. Excellent water resistance and adhesive qualities, and being of extreme pressure type. (Timken OK 40 pounds minimum.)
EPGL -	Extreme Pressure Gear Lube (oil) meeting API service classification GL-5 or MIL-Spec MIL-L-2105.
HO -	Hydraulic Oil. ISO-Vg grade 32, 46.
CL -	Chain Lube. Use a good quality chain lubricant

424 hydraulic oil, which has an SAE viscosity of 10W-30 and a viscosity index of 152.

For cold weather applications, i.e. when temperatures remain consistently below +20°F (-7°C) JLG recommends using Mobil DTE 13 hydraulic oil.

Aside from JLG recommendations, it is not advisable to mix oils of different brands or types, as they may not contain the same required additives or be of comparable viscosities. If use of hydraulic oil other than Mobilfluid 424 is desired, contact JLG Industries for proper recommendations.

NOTE: Refer to Lubrication Chart, Table 7-2 on page 7-9 for specific lubrication locations on machine.

Hydraulic Oil (HO)

HYDRAULIC SYSTEM OPERATING TEMPERATURE RANGE	SAE VISCOSITYGRADE
+0° F to +180° F (-18° C to +83° C)	10W
+0° F to +210° F (-18° C to +99° C)	10W-20, 10W-30
+50° F to +210° F (+10° C to +99° C)	20W-20

Hydraulic oils must have anti-wear qualities at least to API Service Classification GL-3, and sufficient chemical stability for mobile hydraulic system service. JLG Industries, recommends Mobilfluid

SECTION 7 - GENERAL SPECIFICATIONS AND OPERATOR MAINTENANCE

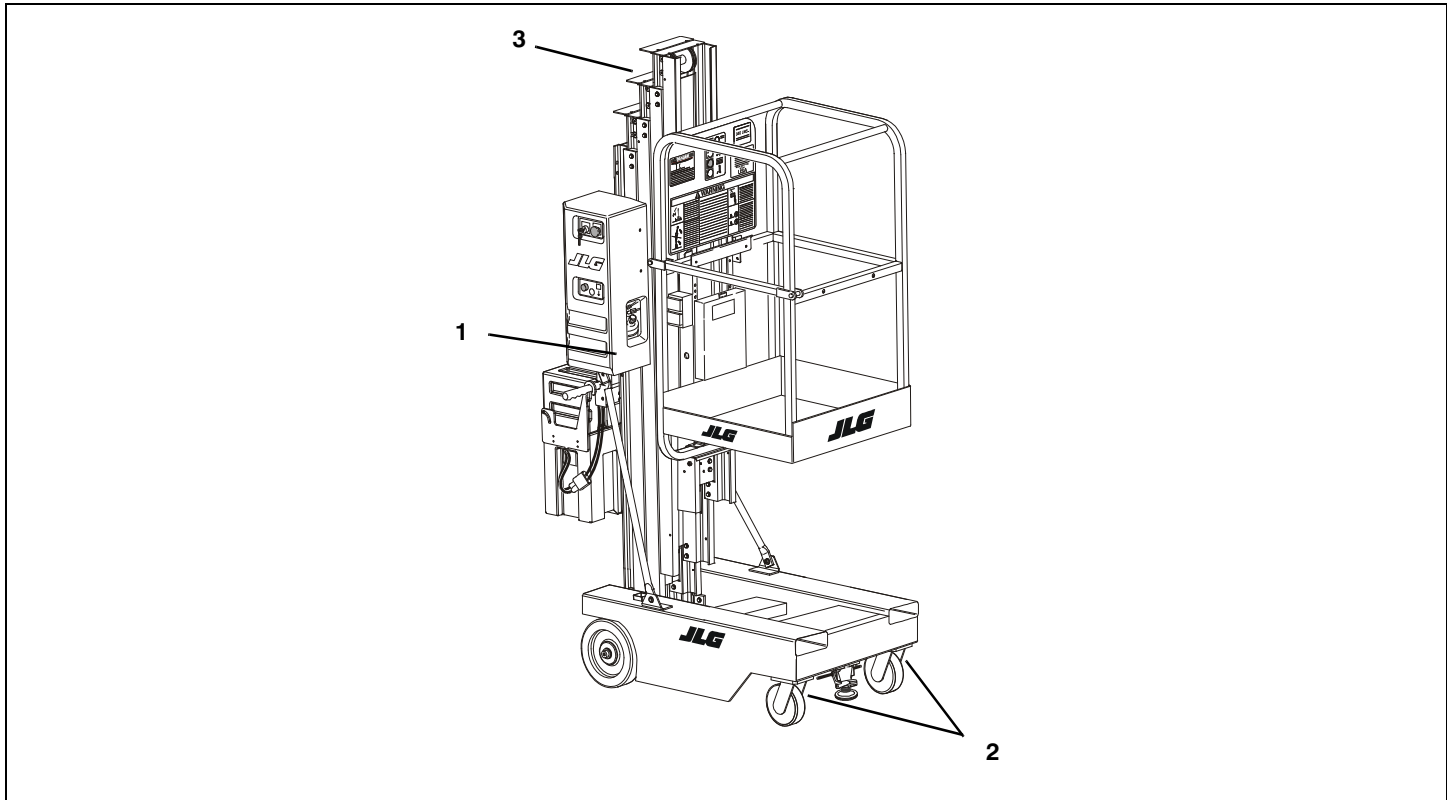

SECTION 7 - GENERAL SPECIFICATIONS AND OPERATOR MAINTENANCE

Table 7-2. Lubrication Intervals for Various Components

ITEM	COMPONENT	NO/TYPE LUBE POINTS	LUBE/METHOD	INTERVAL HOURS				COMMENTS
				3 MONTHS 150 Hrs.	6 MONTHS 300 Hrs.	1 YEAR 600 Hrs.	2 YEARS 1200 Hrs.	
1	Hydraulic Oil	Fill To Line on Reservoir 5 Qt. Reservoir	HO - Check Hyd. Oil Level HO - Change Hyd. Oil	—	—	—	✓	Check Hydraulic Oil every 10 hrs. Change Hydraulic Oil every 1200 hrs.
2	Swivel Raceways	2 - Front Casters	MPG - Pressure Gun	—	✓	—	—	
3	Mast Chains *	2 - Per Section	CL - Brush or Spray	—	✓	—	—	Inspect, lubricate if drying or rusting.
<p>* Applies Only to Mast Sections with Chains.</p> <p>Key to Lubricants: MPG - Multipurpose Grease HO - Hydraulic Oil CL - Chain Lube. Use a good quality chain lubricant</p>								
<p>Notes: 1. Lubricate like items on each side of the machine. 2. Recommended lubricating intervals are based on normal use. If machine is subjected to severe operating conditions, such as a high number of cycles, location, corrosive/dirty environment, etc., user must adjust lubricating requirements accordingly. 3. Lubricating intervals are calculated on 50 hours of machine operation a week. 4. Prior to checking hydraulic oil level, operate machine through one complete cycle of lift function (full up and down). Failure to do so will result in incorrect oil level reading on the hydraulic reservoir.</p>								

7.4 SUPPLEMENTAL INFORMATION

The following information is provided in accordance with the requirements of the European Machinery Directive 2006/42/EC and is only applicable to CE machines.

For electric powered machines, the equivalent continuous A-Weighted sound pressure level at the work platform is less than 70dB(A).

For combustion engine powered machines, guaranteed Sound Power Level (LWA) per European Directive 2000/ 14/EC (Noise Emission in the Environment by Equipment for Use Outdoors) based on test methods in accordance with Annex III, Part B, Method 1 and 0 of the directive, is 109 dB.

The vibration total value to which the hand-arm system is subjected does not exceed 2,5 m/s². The highest root mean square value of weighted acceleration to which the whole body is subjected does not exceed 0,5 m/s².

SECTION 8. INSPECTION AND REPAIR LOG

Machine Serial Number: _____

Table 8-1. Inspection and Repair Log

Date	Comments

SECTION 8 - INSPECTION AND REPAIR LOG

Machine Serial Number: _____

Table 8-1. Inspection and Repair Log

Date	Comments



An Oshkosh Corporation Company

TRANSFER OF OWNERSHIP

To Product Owner:

If you now own but **ARE NOT** the original purchaser of the product covered by this manual, we would like to know who you are. For the purpose of receiving safety-related bulletins, it is very important to keep JLG Industries, Inc. updated with the current ownership of all JLG products. JLG maintains owner information for each JLG product and uses this information in cases where owner notification is necessary.

Please use this form to provide JLG with updated information with regard to the current ownership of JLG products. Please return completed form to the JLG Product Safety & Reliability Department via facsimile or mail to address as specified below.

Thank You,
Product Safety & Reliability Department
JLG Industries, Inc.
13224 Fountainhead Plaza
Hagerstown, MD 21742
USA
Telephone: +1-717-485-6591
Fax: +1-301-745-3713

NOTE: Leased or rented units should not be included on this form.

Mfg. Model: _____

Serial Number: _____

Previous Owner: _____

Address: _____

Country: _____ Telephone: (_____) _____

Date of Transfer: _____

Current Owner: _____

Address: _____

Country: _____ Telephone: (_____) _____

Who in your organization should we notify?

Name: _____

Title: _____

PROPOSITION 65 WARNING

- **Battery posts, terminals and related accessories contain lead and lead compounds, chemicals known to the State of California to cause cancer and reproductive harm.**
- **Batteries also contain other chemicals known to the State of California to cause cancer.**
- **Wash hands after handling.**



An Oshkosh Corporation Company

JLG Industries, Inc.
1 JLG Drive
McConnellsburg PA. 17233-9533
USA

 (717) 485-5161

 (717) 485-6417



3121212

JLG Worldwide Locations

JLG Industries (Australia)
P.O. Box 5119
11 Bolwarra Road
Port Macquarie
N.S.W. 2444
Australia

 +61 2 65 811111

 +61 2 65 810122

JLG Latino Americana Ltda.
Rua Eng. Carlos Stevenson,
80-Suite 71
13092-310 Campinas-SP
Brazil

 +55 19 3295 0407

 +55 19 3295 1025

JLG Industries (UK) Ltd
Bentley House
Bentley Avenue
Middleton
Greater Manchester
M24 2GP - England

 +44 (0)161 654 1000

 +44 (0)161 654 1001

JLG France SAS
Z.I. de Baulieu
47400 Faulliet
France

 +33 (0)5 53 88 31 70

 +33 (0)5 53 88 31 79

JLG Deutschland GmbH
Max-Planck-Str. 21
D - 27721 Ritterhude - Ihlpohl
Germany

 +49 (0)421 69 350 20

 +49 (0)421 69 350 45

JLG Equipment Services Ltd.
Rm 1107 Landmark North
39 Lung Sum Avenue
Sheung Shui N. T.
Hong Kong

 (852) 2639 5783

 (852) 2639 5797

JLG Industries (Italia) s.r.l.
Via Po. 22
20010 Pregnana Milanese - MI
Italy

 +39 029 359 5210

 +39 029 359 5845

JLG Europe B.V.
Polaris Avenue 63
2132 JH Hoofddorp
The Netherlands

 +31 (0)23 565 5665

 +31 (0)23 557 2493

JLG Polska
Ul. Krolewska
00-060 Warszawa
Poland

 +48 (0)914 320 245

 +48 (0)914 358 200

JLG Industries (Scotland)
Wright Business Centre
1 Lonmay Road
Queenslie, Glasgow G33 4EL
Scotland

 +44 (0)141 781 6700

 +44 (0)141 773 1907

Plataformas Elevadoras
JLG Iberica, S.L.
Trapadella, 2
P.I. Castellbisbal Sur
08755 Castellbisbal, Barcelona
Spain

 +34 93 772 4700

 +34 93 771 1762

JLG Sverige AB
Enkopingsvagen 150
Box 704
SE - 176 27 Jarfalla
Sweden

 +46 (0)850 659 500

 +46 (0)850 659 534