

# 1 Summary and features

*Ksib*



**DC** INVERTER  
TECHNOLOGY

ULTIMATE COOLING & HEATING SOLUTION

**KLIMAIRE**®

**3 Part name**

**Indoor Unit**

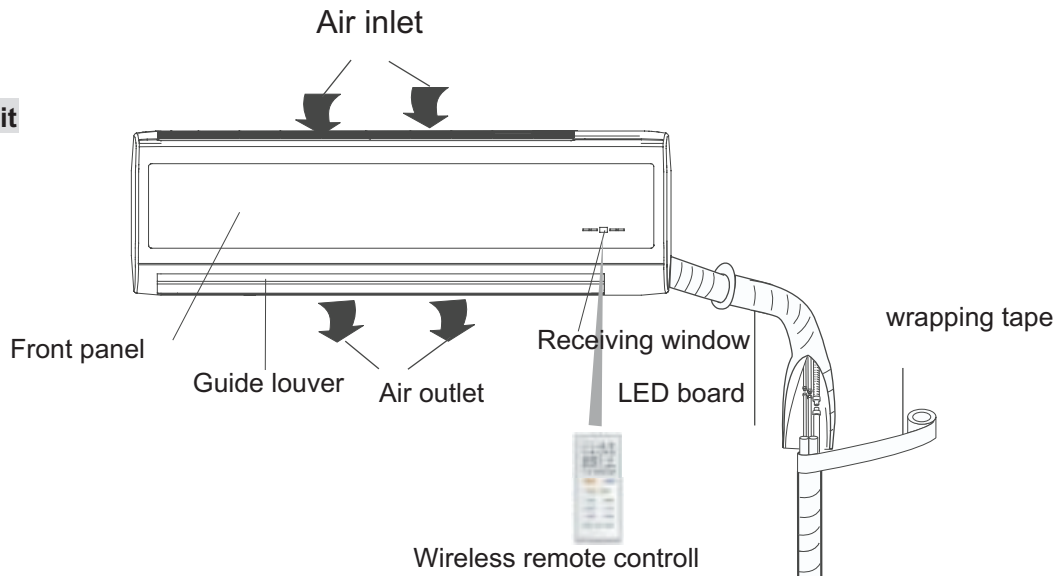

**Outdoor Unit**

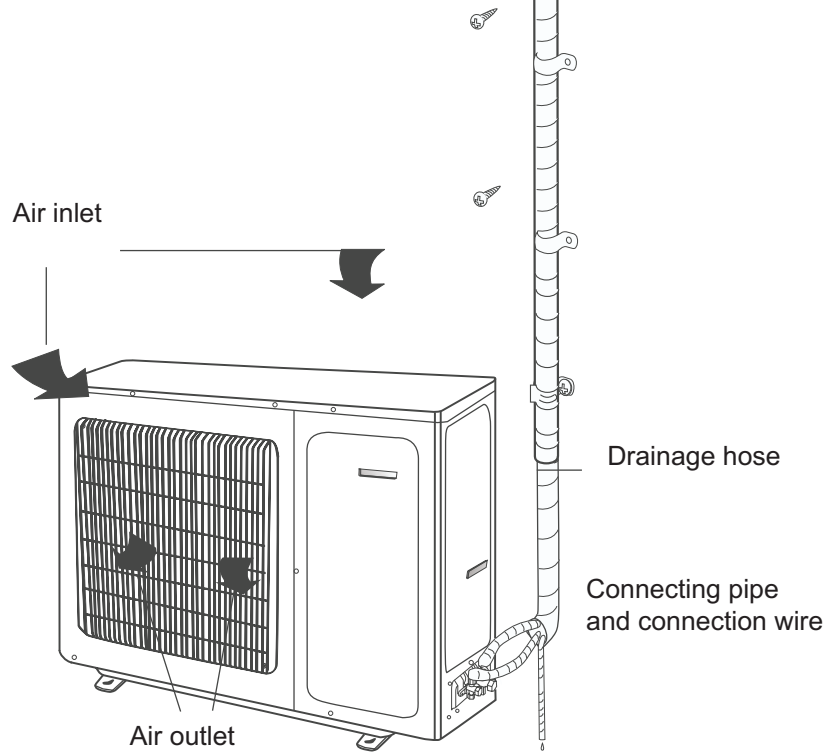

## 4 Overall and Installing Dimension

### 4.1 Overall and Installing Dimension of Indoor Unit

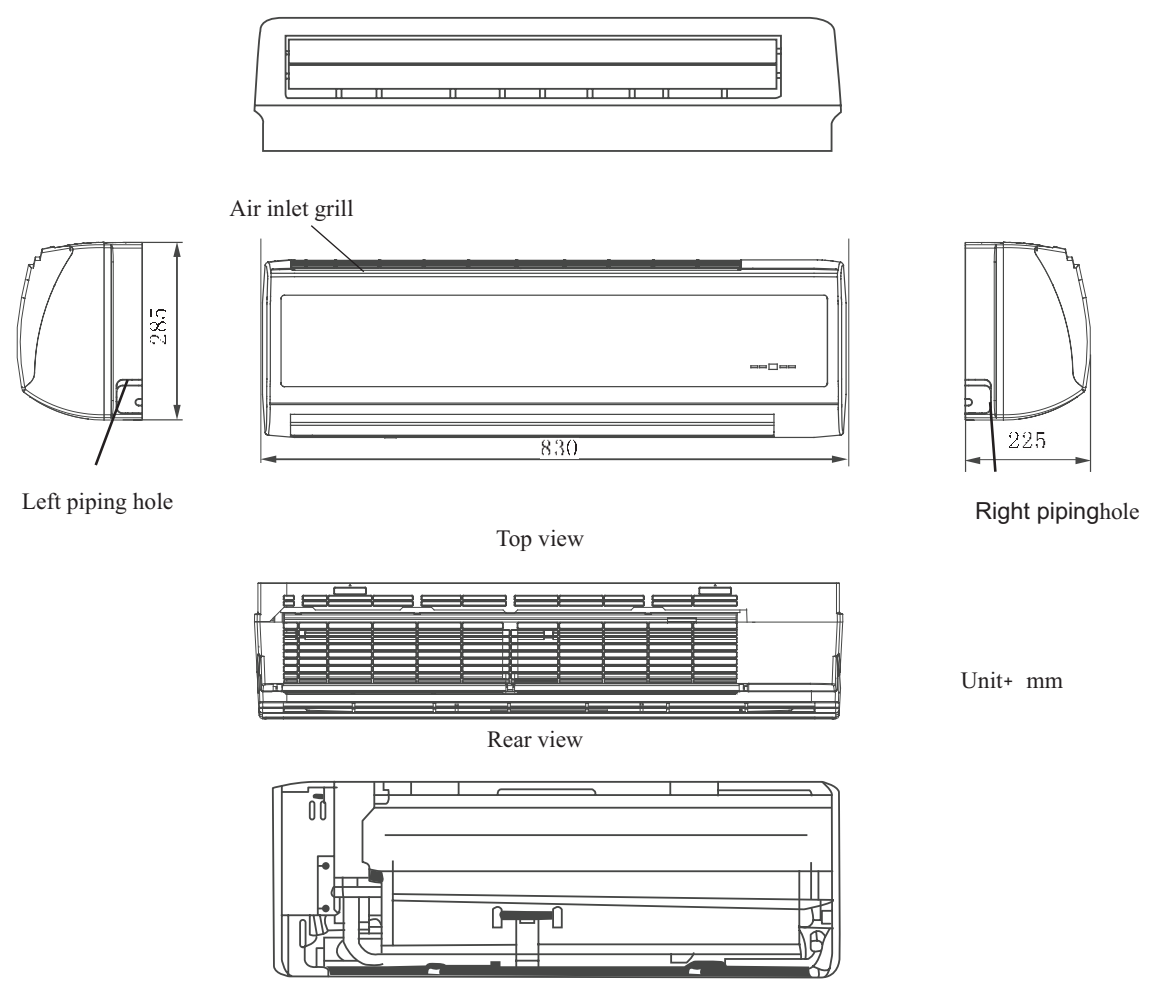

Unit+ mm

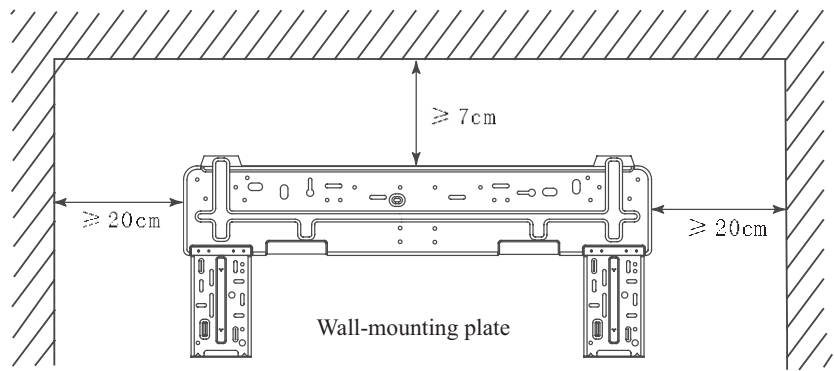

## 4. 2 Overall and Installing Dimension of Outdoor Unit

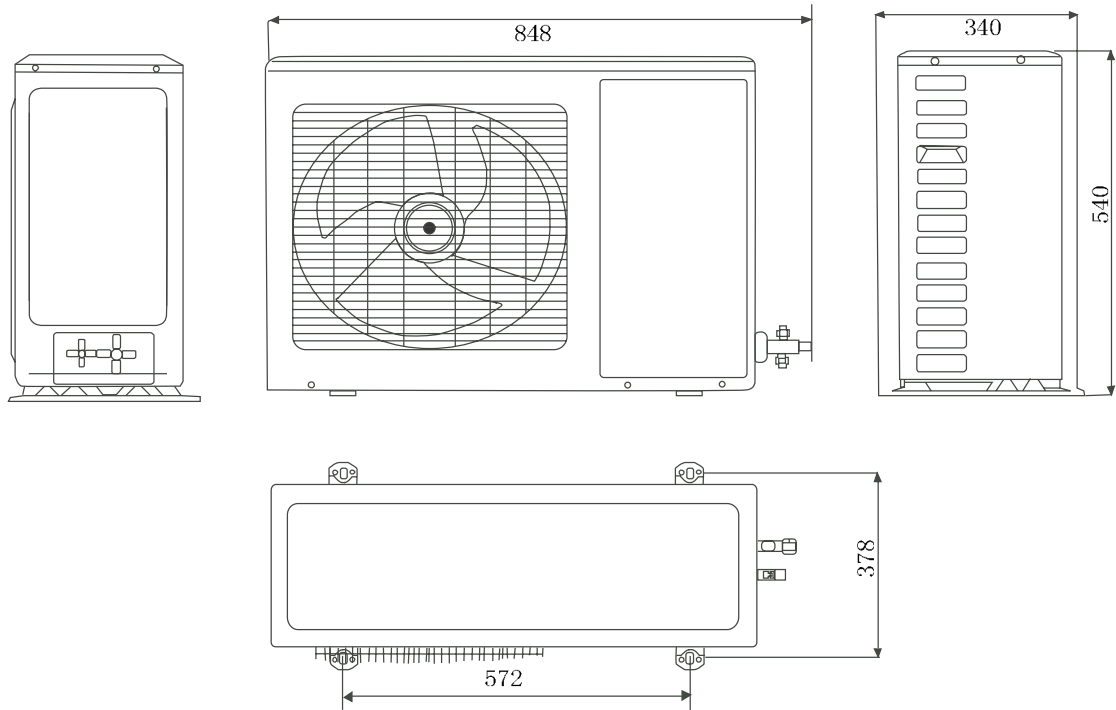

Unit: mm

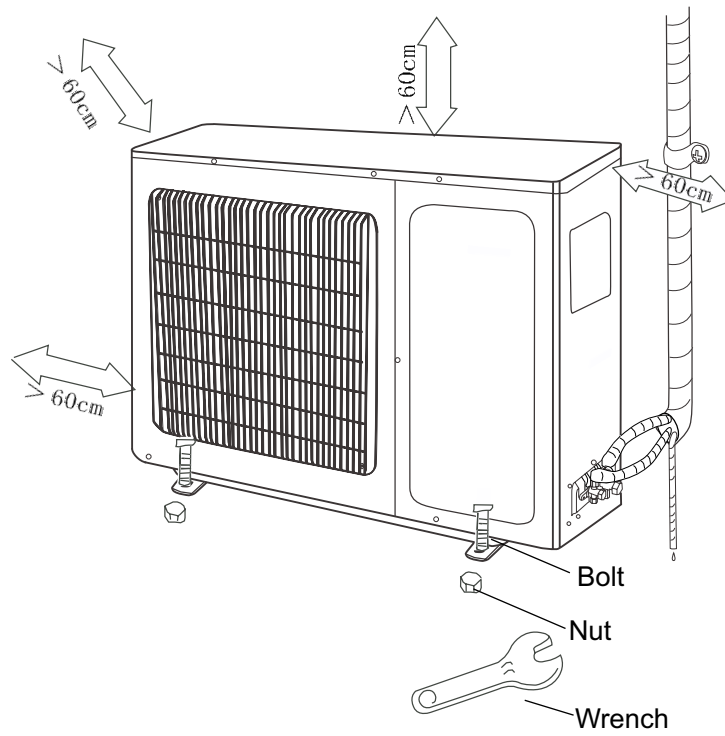

## 6 Function manual and operation method of remote controller

### 6.1 Function manual of remote controller

This function manual is applicable to D.C. Variable Frequency Linge Wind Series:GWHD12A6ND31A

#### 6.1.1 Temperature parameters

- ◆ Room set temperature ( $T_{set}$ )
- ◆ Room ambient temperature ( $T_{amb}$ )

#### 6.1.2 Fundamental functions

After powered on, no matter when the compressor is started, the time interval between two startups cannot be less than 3 minutes.

##### 6.1.2.1 COOL mode

##### 6.1.2.1.1 The condition and process of cooling

If  $T_{amb} \geq T_{set}$ , COOL mode will act, the compressor and outdoor fan will run, and the indoor fan will run at the set speed.

If  $T_{amb} \leq T_{set} - 2^\circ\text{C}$ , the compressor will stop, the outdoor fan will delay 30 seconds to stop, and the indoor fan will run at the set speed.

If  $T_{set} - 2^\circ\text{C} < T_{amb} < T_{set}$ , the unit will keep running in the previous mode.

- In this mode, the reversal valve will not be powered on and the temperature setting range is  $16^\circ\text{C} \sim 30^\circ\text{C}$ .
- The unit will adjust the running frequency of the compressor automatically according to the change of ambient temperature.

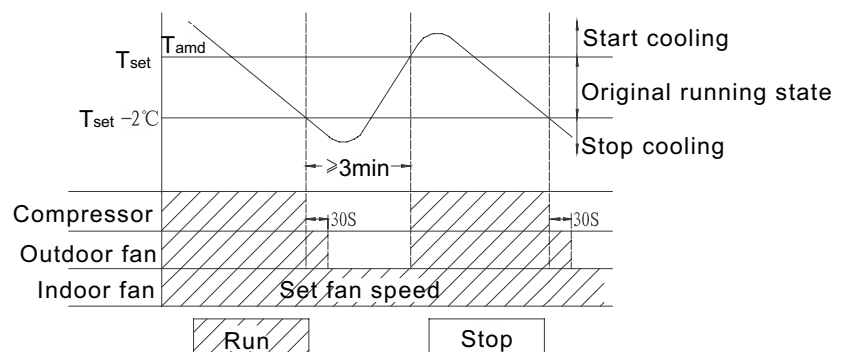

##### 6.1.2.1.2 Protection function

##### ◆ Antifreezing protection

Under cooling and drying mode, after the compressor run about 10mins, when the pipe temp. of the evaporator is too low, the compressor will stop, the outdoor fan will stop after 30s, under cooling mode the indoor fan and swing motor will keep running in the original mode, under drying mode the indoor fan will run at low fan speed, the swing motor will run in the original mode. When antifreezing protection is eliminated and the compressor has stopped for 3 minutes, the unit will resume running in the original mode.

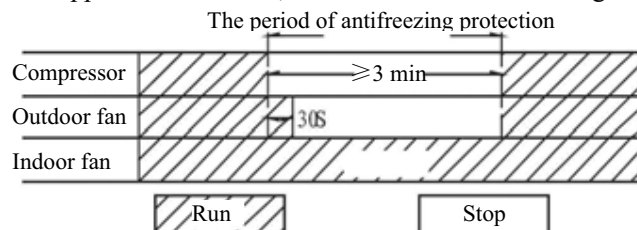

##### ◆ Overcurrent protection

If total current is high, the compressor will run in limited or dropped frequency. When total current goes on rising over the stated value, the compressor will stop, the outdoor fan will delay 30 seconds to stop.

#### 6.1.2.2 DRY mode

##### 6.1.2.2.1 The condition and process of drying

If  $T_{amb} > T_{set}$ , DRY mode will act, the indoor fan, outdoor fan and compressor will run, and indoor fan will run at low speed

If  $T_{set} - 2^{\circ}\text{C} \leq T_{amb} \leq T_{set}$ , the unit will keep running in the original mode.

If  $T_{amb} < T_{set} - 2^{\circ}\text{C}$ , the compressor will stop running, the outdoor fan will delay 30 seconds to stop and the indoor fan will run at low speed.

➤ In this mode, the reversal valve will not be powered on and the temperature setting range is  $16^{\circ}\text{C} \sim 30^{\circ}\text{C}$ .

➤ The unit will adjust the running frequency of the compressor automatically according to the change of ambient temperature.

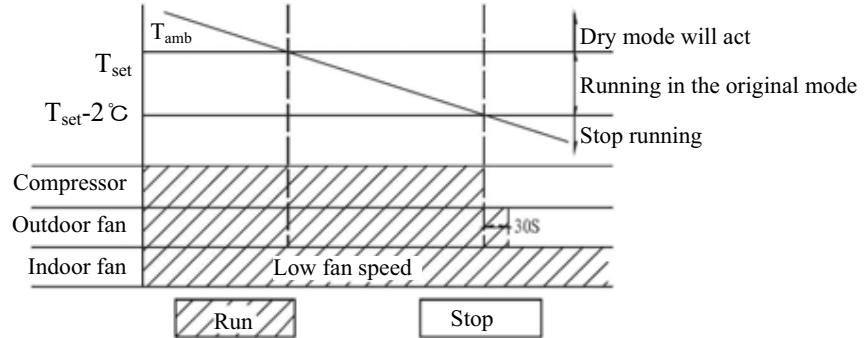

#### 6.1.2.2.2 Protection

◆ Protection is the same with that in COOL mode.

#### 6.1.2.3 HEAT mode

##### 6.1.2.3.1 The condition and process of heating

If  $T_{amb} \leq T_{set} + 2^{\circ}\text{C}$ , HEAT mode will act, the compressor, outdoor fan and 4-way valve will run simultaneously, the indoor fan will delay at most for 2min to run.

If  $T_{set} + 2^{\circ}\text{C} < T_{amb} < T_{set} + 5^{\circ}\text{C}$ , the unit will keep running in the original mode.

If  $T_{amb} \geq T_{set} + 5^{\circ}\text{C}$ , the compressor will stop, the outdoor fan will delay 30sec to stop and the indoor fan will blow for 60sec at the original speed and then stop.

➤ In this mode, the temperature setting range is  $16^{\circ}\text{C} \sim 30^{\circ}\text{C}$ .

➤ The air conditioner will adjust the running frequency of the compressor automatically according to the change of ambient temperature.

➤ When the unit is turned off in HEAT mode, or switched to other mode from HEAT mode, the four-way valve will be powered off 2min later after the compressor stops.

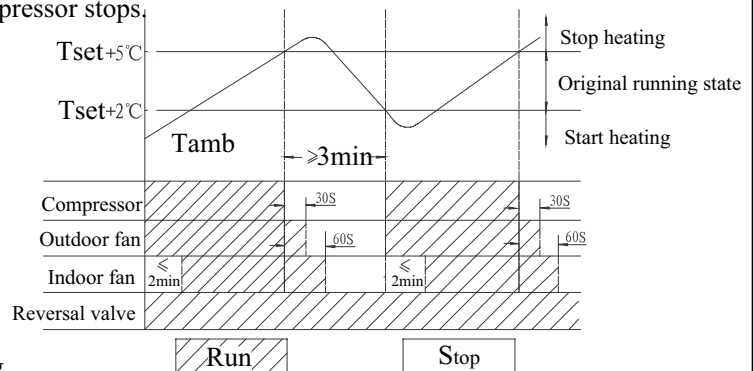

##### 6.1.2.3.2 The condition and process of defrosting

When frost is detected in the condenser, the system will enter into defrosting state. When defrosting starts, the compressor and indoor fan will stop, and the outdoor fan and four-way valve will delay 30 seconds to stop. The compressor will start again after 30s and. When the compressor has run for 8mins, the compressor will stop. After 30 seconds the four-way valve opens and after another 60 seconds, the compressor and outdoor fan resume running. The indoor fan will delay 2 minutes to run at the latest and temperature on the display panel shows H1. Under heating mode, when the compressor is stopped by malfunction, the indoor fan will blow at low fan speed for 60s and then stop.

##### 6.1.2.3.3 Protection

◆ Overcurrent protection

If total current is high, the compressor will run in limited or dropped frequency. When total current go on rising

over the stated value, the compressor will stop, the outdoor fan will delay 30 seconds to stop.

#### 6.1.2.4 FAN mode

In this mode, the indoor fan will run the fan in High, Med, Low and Auto mode. The compressor, outdoor fan and four-way valve will stop.

➤ In this mode, the temperature setting range is 16~30 °C.

➤ The unit will adjust the running frequency of the compressor automatically according to the change of ambient temperature.

#### 6.1.2.5 AUTO mode

In this mode, the system selects COOL, HEAT and FAN mode automatically according to the change of ambient temperature. The protection function is the same with that of COOL/HEAT mode.

➤ The unit will adjust the running frequency of the compressor automatically according to the change of ambient temperature.

### 6.1.3 Other control

#### 6.1.3.1 ON / OFF

Each time the On/Off button of the remote controller is pressed, the On/Off state will switch once.

#### 6.1.3.2 MODE selection

Press the MODE button on the remote controller to select and display the following modes:

AUTO, COOL, DRY, FAN, and HEAT.

#### 6.1.3.3 TEMP. setting button

Each time TEMP + or TEMP - button is pressed, the set temperature will be increased or decreased by 1 °C.

Adjusting range is 16~30 °C. In AUTO mode, this button does not function.

#### 6.1.3.4 AUTO key

When the unit is stop, press AUTO key, the unit will run under AUTO mode and the swing motor starts.

When the unit is running, press AUTO key, the unit will be stopped.

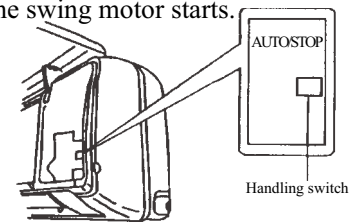

#### 6.1.3.5 Timer control

The unit is turned on or off according to the timer set by the remote controller.

#### 6.1.3.6 Sleep control

When the air conditioner is in COOL or DRY mode, after Sleep mode has been set properly, the preset  $T_{set}$  will be increased by 1 °C after the sleep program has run for 1 hour, and  $T_{set}$  will be increased by another 1 °C after 2 hours.  $T_{set}$  has been increased by 2 °C totally in two hours. Then the unit will run at this set temperature and at the set speed.

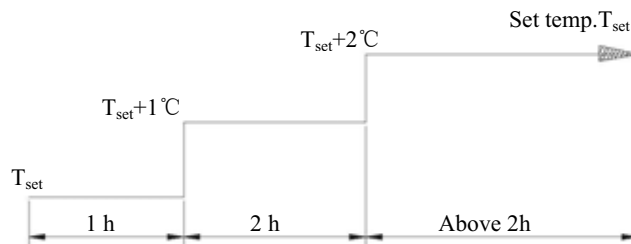

When the air conditioner is in HEAT mode, after Sleep mode has been set properly, the preset  $T_{set}$  will be decreased by 1 °C after the sleep program has run for 1 hour, and  $T_{set}$  will be decreased by another 1 °C after 2 hours.  $T_{set}$  has been increased by 2 °C totally in two hours. Then the unit will run at this set temperature and at the set speed.

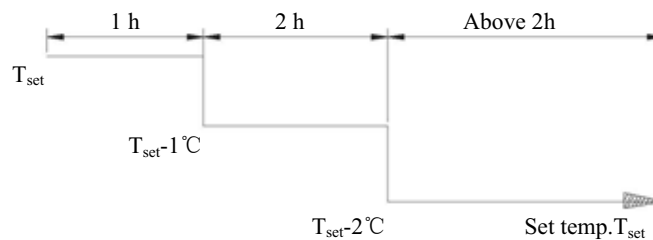

In AUTO or FAN mode, the setting temp. will not change.

#### 6.1.3.7 Indoor fan control

Use the remote controller to set the indoor fan running at HIGH, MED or LOW speed. At this time the fan will run at high, medium or low speed. It can also be set to AUTO and the indoor fan will select fan speed(HIGH, MED or LOW) automatically according to ambient temperature.

➤ There are at least 3mins and 30s delay for fan speed shift.

#### 6.1.3.8 Power supply for outdoor unit

The power supply for outdoor unit is turned on in AUTO, COOL, HEAT and DRY mode under turn-on state.

The power supply for outdoor unit will delay 3 minutes to turn off under turn-off state or in the FAN mode under turn-on state.

#### 6.1.3.9 Swing control

Use the SWING button of the wireless remote control to control SWING On and Off. Swing will only act when indoor fan is running. After power on, the swing motor turns back to 0 position and closes the air outlet vent; if it does not preset swing, after the unit is turned on, it will turn to the max. air outlet D1 position; then turn back to L position under COOL mode. Under HEAT mode, the guide louver stays at D1; when in swinging state, it will swing between L1 and D1 position. When the unit is turned off, it will turn back to 0 position.

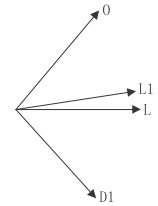

#### 6.1.3.10 Buzzer control

When the unit is power on or receives remote control signal or the auto key be pressed, the buzzer will give out a beep.

#### 6.1.3.11 Power-off memory function

Contents of memory: Mode; Swing; Set fan speed, Set temperature, Timing etc.

Under turn-on state, when power off and power on, the power supply for outdoor unit will be turn on after 3mins .

Under turn-off state, when power off and power on, the power supply for outdoor unit will be turn on immediately.

#### 6.1.3.12 Delay Protection of Compressor

Under COOL; DRY; HEAT mode, before each time the compressor starts, there will be 3mins delay.

#### 6.1.4. Common protection function in each mode

##### 6.1.4.1 Overload protection

T<sub>tube</sub>: at cooling, it detects the temp. of outdoor heat exchanger, at heating, it detects the temp. of indoor heat exchanger.

When T<sub>tube</sub> is detected high, the compressor will run in limited frequency. When T<sub>tube</sub> goes on rising over the stated value, the compressor will stop, under AUTO HEAT or HEAT mode, indoor fan will blow 60s at low fan speed and then stop, under other mode, the indoor fan will run at set speed.

##### 6.1.4.2 Compressor discharge temperature protection

When discharge temperature is too high to over the stated value, the compressor will stop, and When discharge temp. resume normal and the compressor has stopped for 3 minutes, the unit will resume its original operating status.

##### 6.1.4.3 Communication malfunction

When not receiving correct signal for 3 minutes, the unit has communication malfunction and the outdoor unit stops, it is the same as normal stop when meeting the set temp..

##### 6.1.4.4 Module protection

When module is in protection, the compressor will stop, after the compressor has stopped for 3 minutes, it will resume to running. During module protection period, the indoor unit displays malfunction and the whole unit stops.



## 7 Disassembly procedures

### 7.1 Disassembly procedures for indoor unit

#### Operation procedures/pictures

#### 7.1.1 Disassembling the front panel and electric box cover

Unloose the clasps on both sides and lift the panel upward. Unplug the two connecting terminals of the display and slide out the rear clasp from the groove to take off the front panel.(you can use panel support bar to support the panel) Screw off the fixing screws of the electric box cover and open the electric box top cover to take it off.

As shown in Fig.7-1

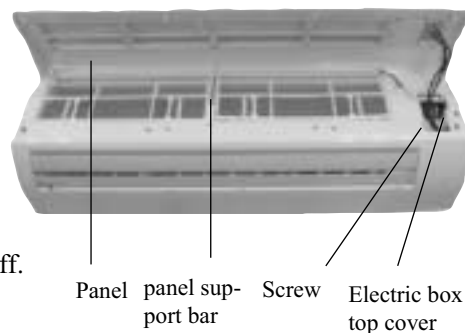

Fig.7-1

#### 7.1.2 Filter

Push the filter up to unloose the clasp to pull out the two filters.

As shown in Fig.7-2

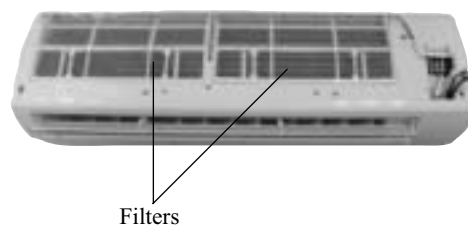

Fig.7-2

#### 7.1.3 Disassembling the guide louver

Bend the guide louver with strength and let out the rotating shaft from the groove to take off the guide louver. As shown in Fig.7-3

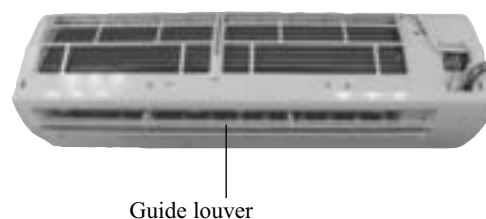

Fig.7-3

## Operation procedures/pictures

### 7.1.4 ||||| Disassembling the front panel body

Unclench the 3 screw covers and screw off the 3 pieces of screws that fix the panel body. Unloose the front and rear clasps to take off the panel body.

As shown in Fig.7-4

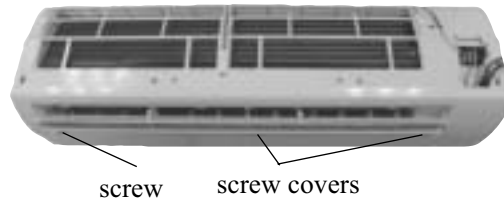
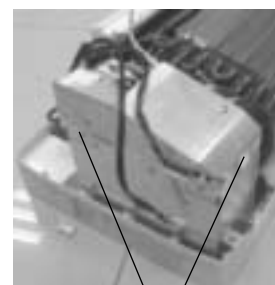

Fig.7-4

### 7.1.5 ||||| Disassembling the electric box cover

Unloose the 3 clasps to take off the electric box cover.

As shown in Fig.7-5



clasps  
Fig.7-5

### 7.1.6 ||||| Disassembling the water-tray assy

Unloose the clasp on the left side and unplug the connecting terminal of the stepping motor. Carefully to remove the water-tray assy because the drainage pipe is placed here. As shown in Fig7-6, 7-7

clasp  
water-tray assy

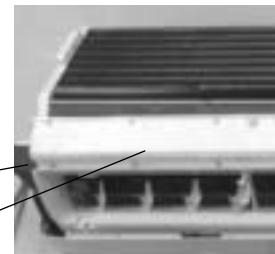

Fig.7-6

connecting terminal



Fig.7-7

## Operation procedures/pictures

### **7.1.7** ||||| **Disassembling the electric box**

Screw off the two pieces of screws that fix the electric box and unloose the clasp. Pull out the tube sensor, unloose the grounding nut and unplug the motor connecting terminal take out the electric box.

As shown in Fig 7-8

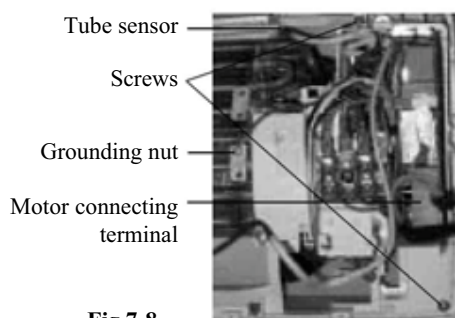
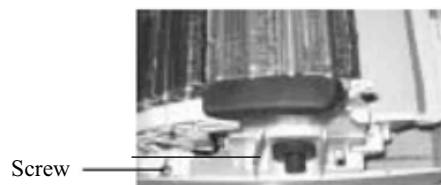

**Fig 7-8**

### **7.1.8** ||||| **Disassembling the evaporator assy**

Screw off the screws that fix the evaporator, one piece on the left and two pieces on the right. As shown in Fig 7-9, 7-10

Lift the left end of the evaporator slightly upward with your end and push it rearward to let out the side clasps of the evaporator from the groove. Take out the evaporator carefully and pay attention to protecting the connecting pipe.



**Fig 7-9**

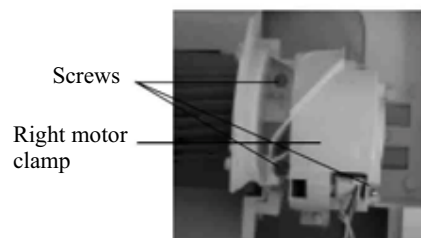

**Fig 7-10**

### **7.1.9** ||||| **Disassembling the motor**

Screw off the 3 pieces of screws that fix the motor clamp to take off the motor clamp. As shown in Fig.7-11

Screw off the fixing nut that fixes the cross flow fan to pull out the motor from the cross flow fan. As shown in Fig.7-12



**Fig 7-11**

### **7.1.10** ||||| **Disassembling the cross flow fan**

Refer to the above steps to take out the cross flow fan from the base plate after taking out the motor.

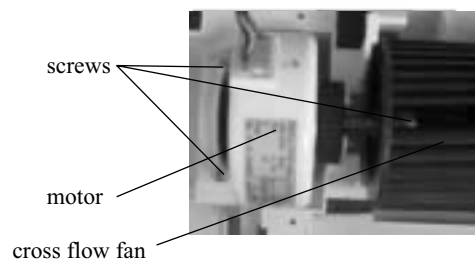

**Fig 7-12**

## 7.2 Disassembly Procedures for Outdoor Unit

### Operating Procedures / Photos

#### 7.2.1 Disassemble Top Cover and Handle

Use screwdriver to unscrew the screw at the handle, and remove the handle. Unscrew the three screws around the top cover, and remove the top cover.

(refer to Figure 7-13)

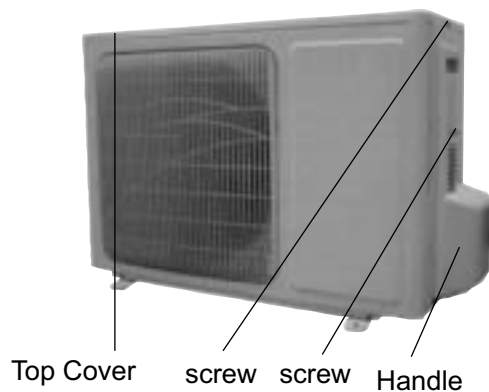

Figure 7-13

#### 7.2.2 Disassemble Rear Grill

Screw out the 4 self tapping screws on rear side plate and chassis of valve supporter and side plate of condenser can take off rear grill.

(refer to Figure 7-14)

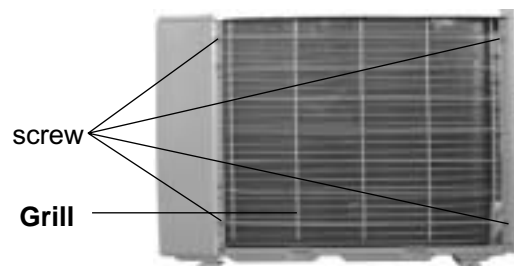

Figure 7-14

#### 7.2.3 Disassemble Components of Panel

Screw out the 5 tapping screws on panel and chassis of valve supporter and side plate of condenser can take off components of panel.

(refer to Figure 7-15)

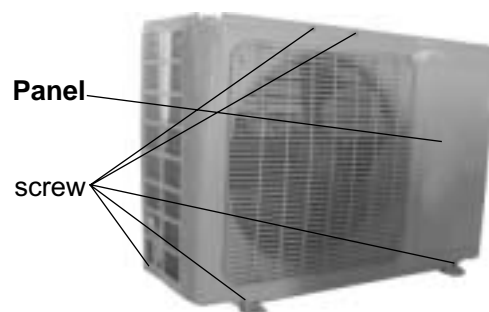

Figure 7-15

## Operating Procedures / Photos

### 7. 2. 4 ||| Disassemble electric install plate

Screw out the 3 bolts that fixing on electric install plate, plug out lead inserter of compressor and fan to take off electric install plate.

(refer to Figure 7-16,7-17)

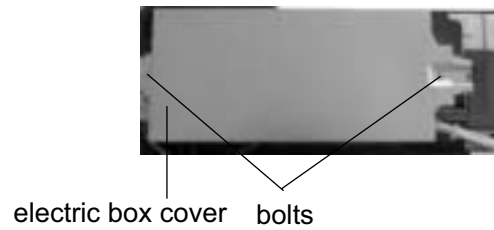

Figure 7-16

### 7. 2. 5 ||| Disassemble Right Side Plate

Screw out the 5 bolts on rear side plate can take off right side plate.

(refer to Figure 7-18)

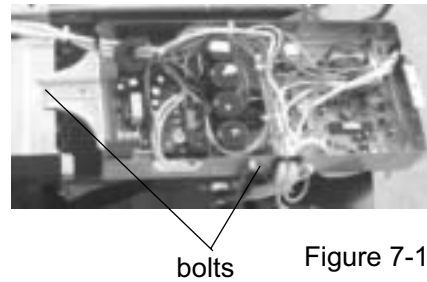

Figure 7-17

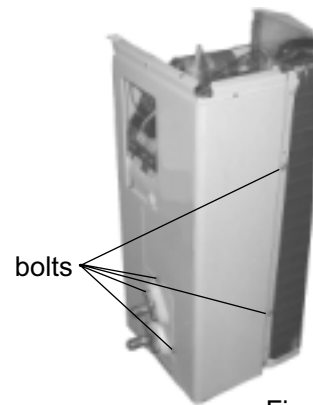

Figure 7-18

### 7. 2. 6 ||| Disassemble axial-flow vane

Loosen tighten nut by spanner to take off nuts, spring washer, flat washer, and take off axial-flow vane forcibly.

(refer to Figure 7-19)

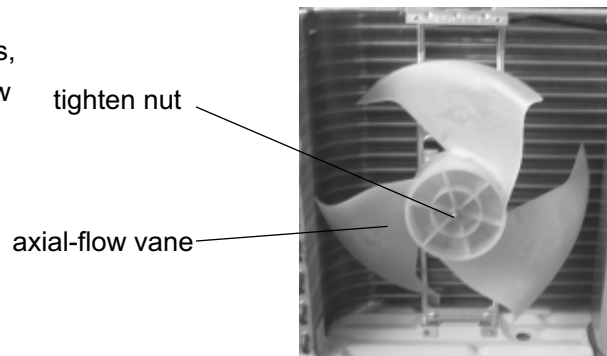

Figure 7-19

## Operating Procedures / Photos

### 7.2.7 ||||| Disassemble Motor and Motor Support

Unscrew the four tapping screws fixing the motor, and remove the motor. Unscrew the two tapping screws fixing the motor support, and lift the motor support to remove it.

(refer to Figure 7-20)

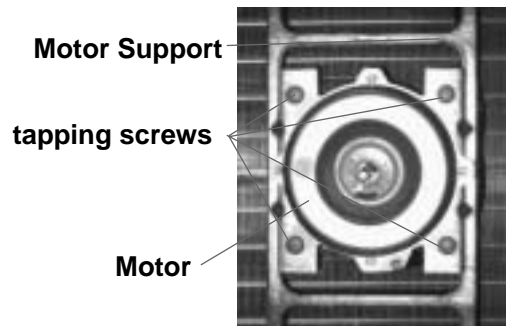

Figure 7-20

### 7.2.8 ||||| Disassemble 4-Way Valve

Screw off the holding nut of the 4-way valve coil and remove the coil. Use wet cotton cloth to wrap the 4-way valve, unsolder the four soldering points connecting the 4-way valve, and remove the 4-way valve. Be quick during the unsoldering process, pay attention to keep the wrapping cloth wet and do not allow the soldering flame to burn the compressor lead-out cable.

(Note: only after discharging all freon).

(refer to Figure 7-21)

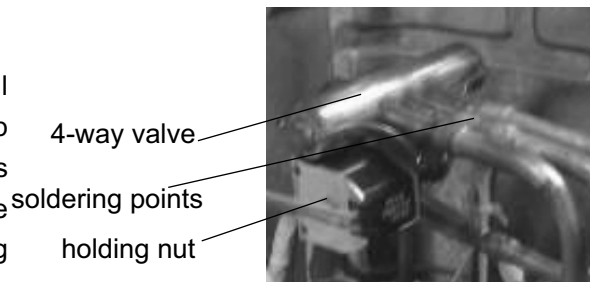

Figure 7-21

### 7.2.9 ||||| Disassemble Capillary Subassembly

Unsolder the soldering points connecting the capillary subassembly and the other pipelines, and remove the capillary subassembly.

(refer to Figure 7-22)



Figure 7-22

## Operating Procedures / Photos

### 7.2.10 ||||| Disassemble Valves

Unscrew the two screws fixing the big valve, unsolder the soldering point between the big valve and the return-air duct and remove the big valve.

(Note: when unsoldering the soldering point, use wet cloth to completely wrap the big valve to prevent valve body from being harmed by high temperature.)

Unscrew the two screws fixing the small valve, unsolder the soldering point connecting the small valve and the fork type pipe, and remove the small valve.

(refer to Figure 7-23)

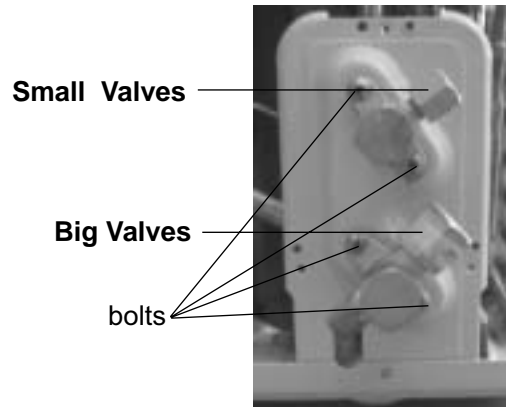

Figure 7-23

### 7.2.11 ||||| Disassemble Compressor

Unscrew the three nuts with washers at the foot of the compressor. Unsolder the soldering points at the suction and the discharge pipes of the compressor, carefully remove the pipes and take out the compressor.

(refer to Figure 7-24)

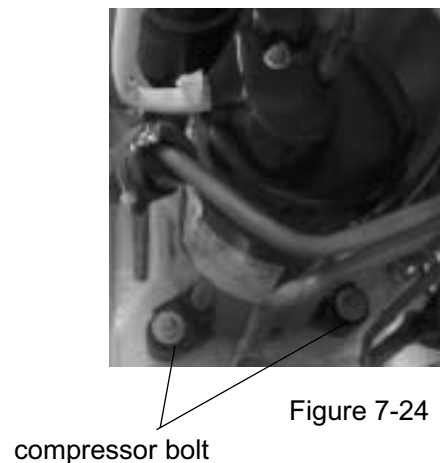
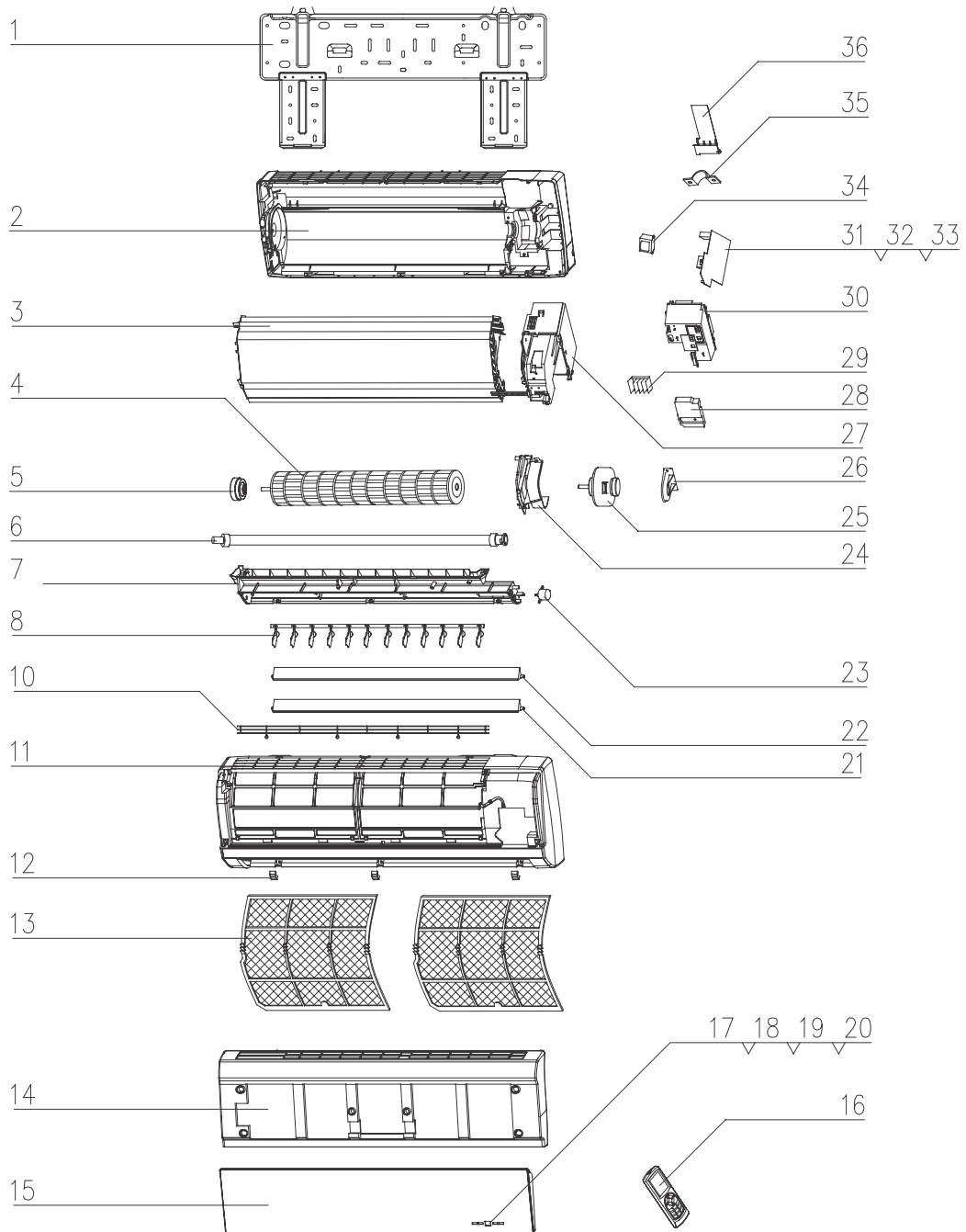

Figure 7-24

# 8

## Exploded View and Components and Parts List

### 8.1 Exploded View of Components and Parts of Indoor Unit





# Exploded View of Outdoor unit

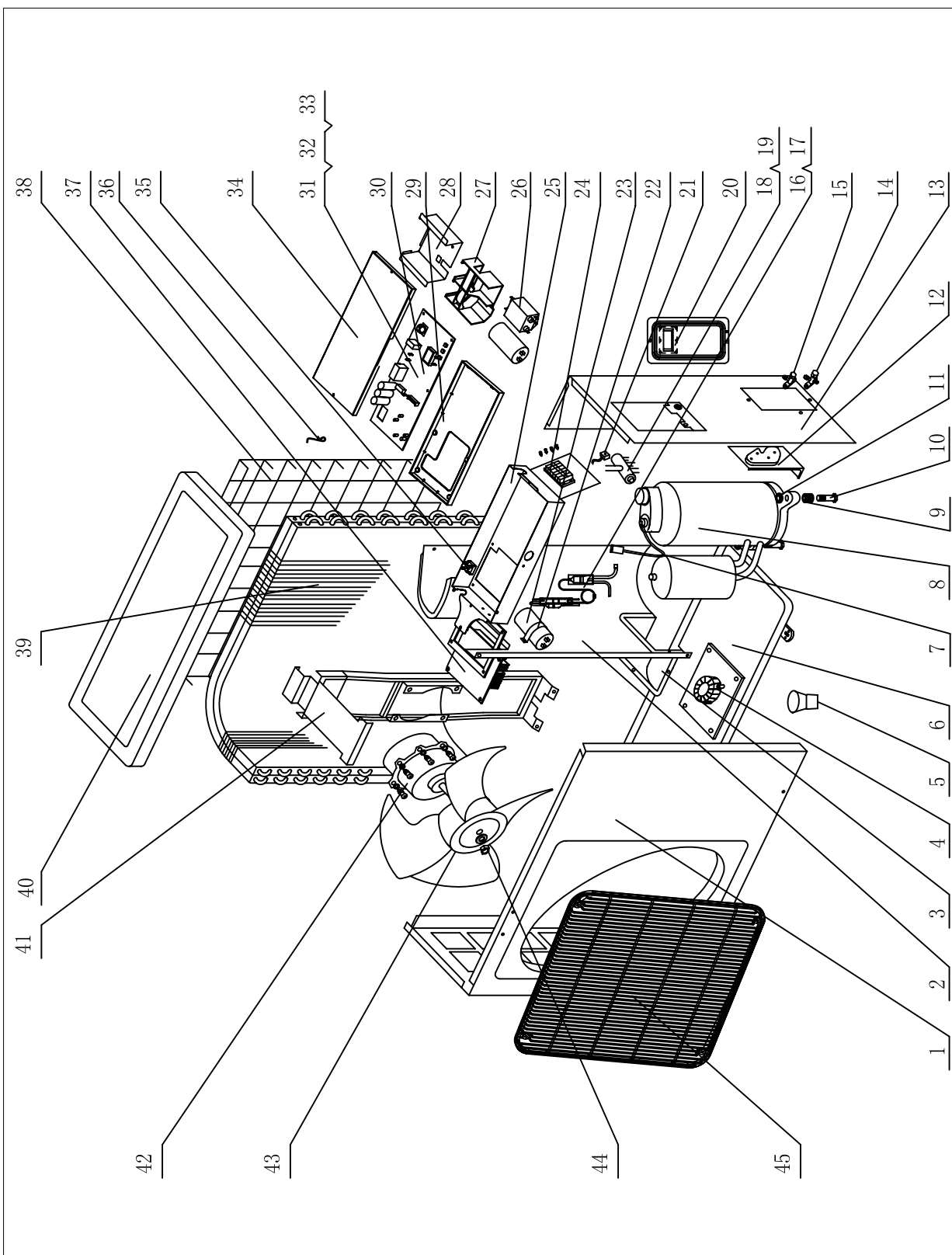

## 9 Troubleshooting

### 9.1 Common section

Analysis in this section is used for Linge Wind D.C. Variable Frequency Series. Before analysis, you can diagnose according to the code displayed on indoor unit or indicator display on outdoor unit. (Refer to 9.2 Malfunction display section).

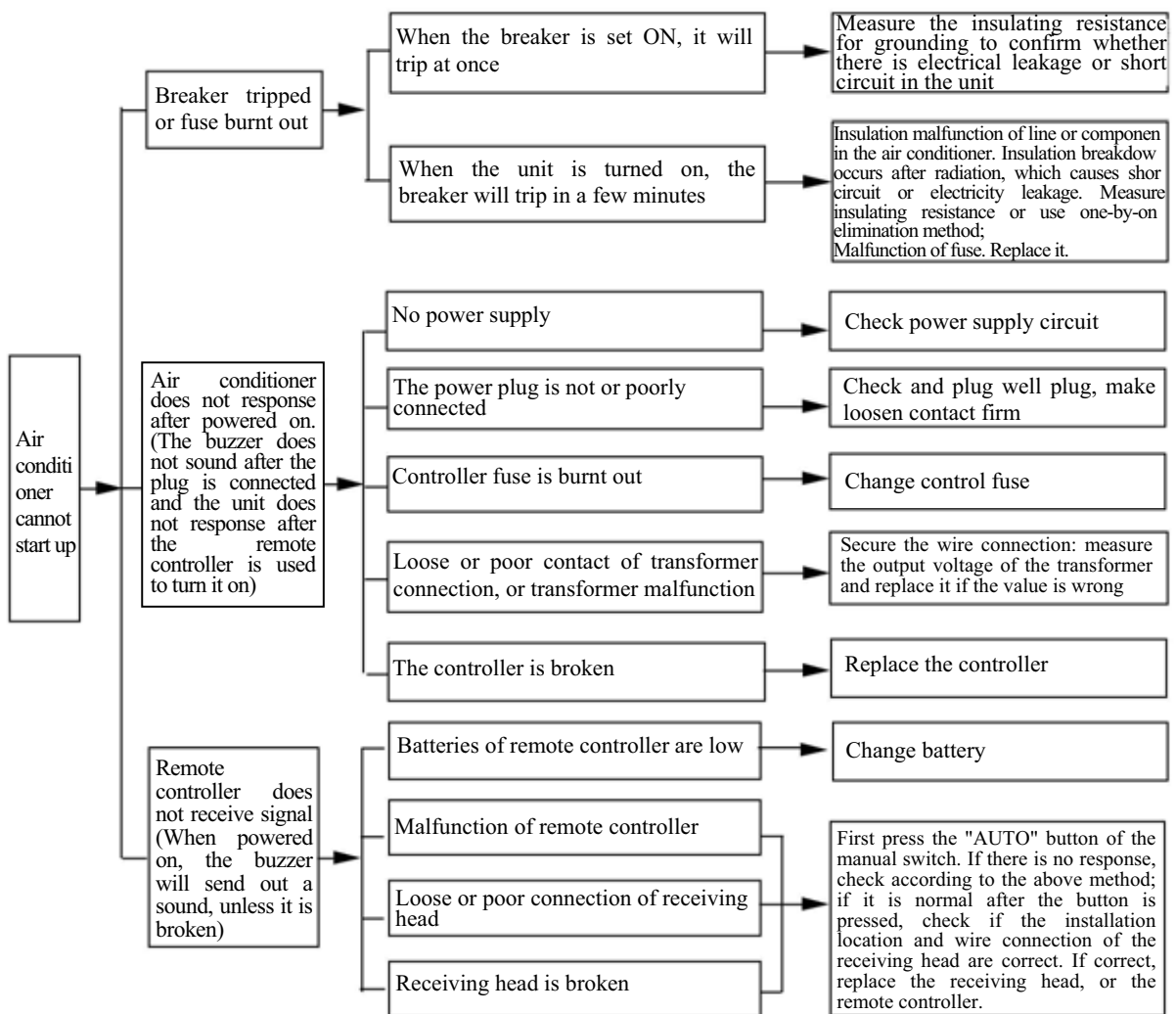

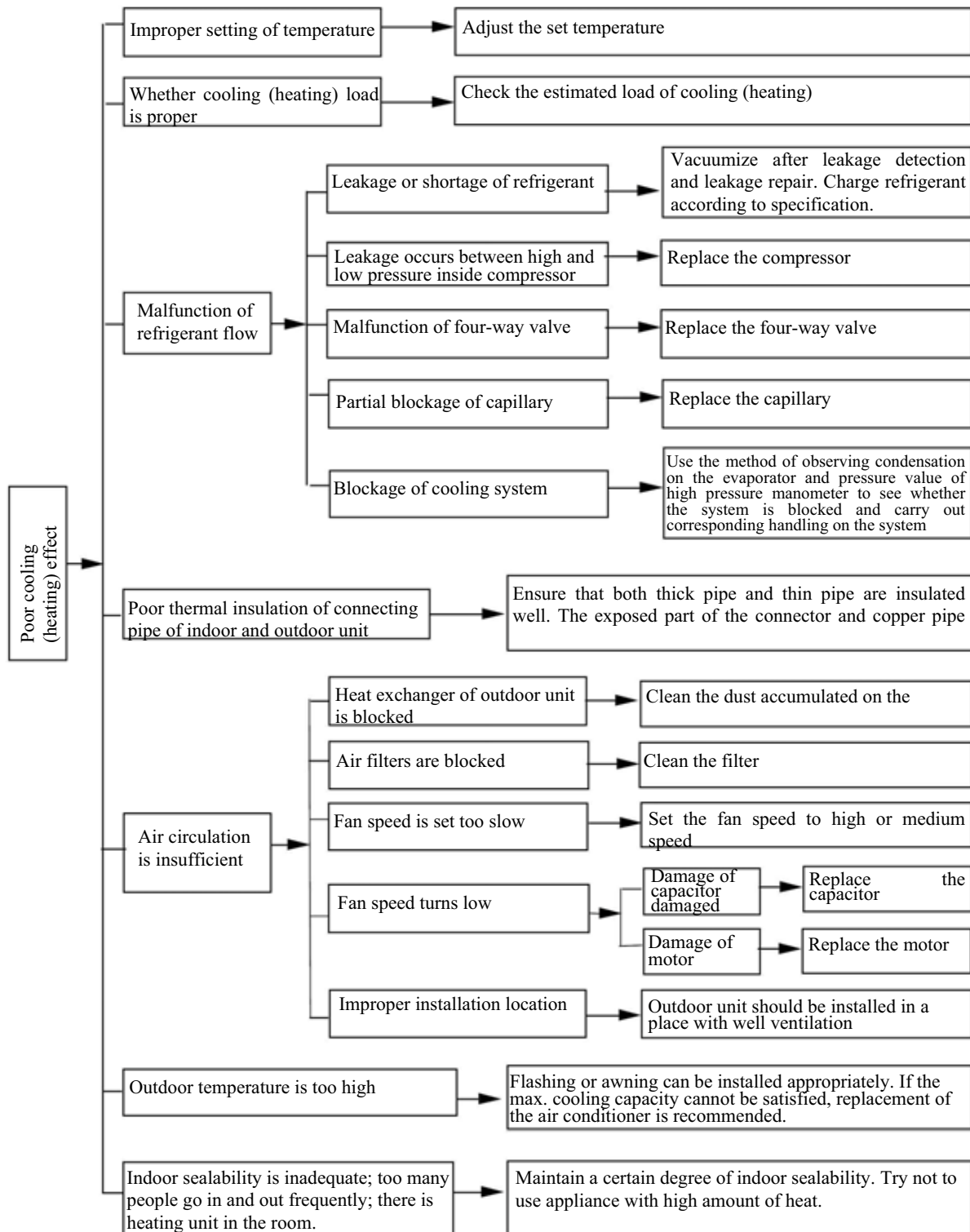

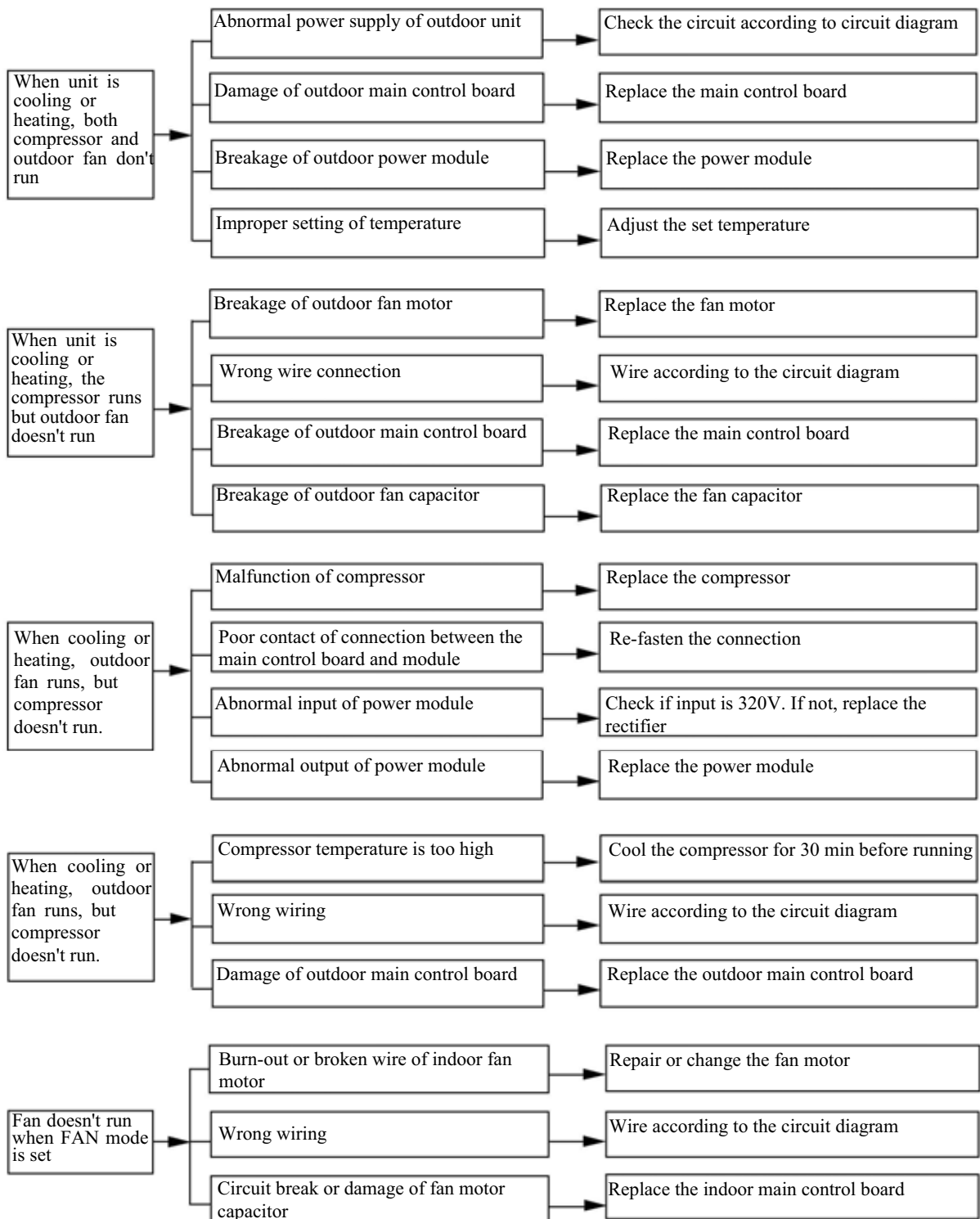

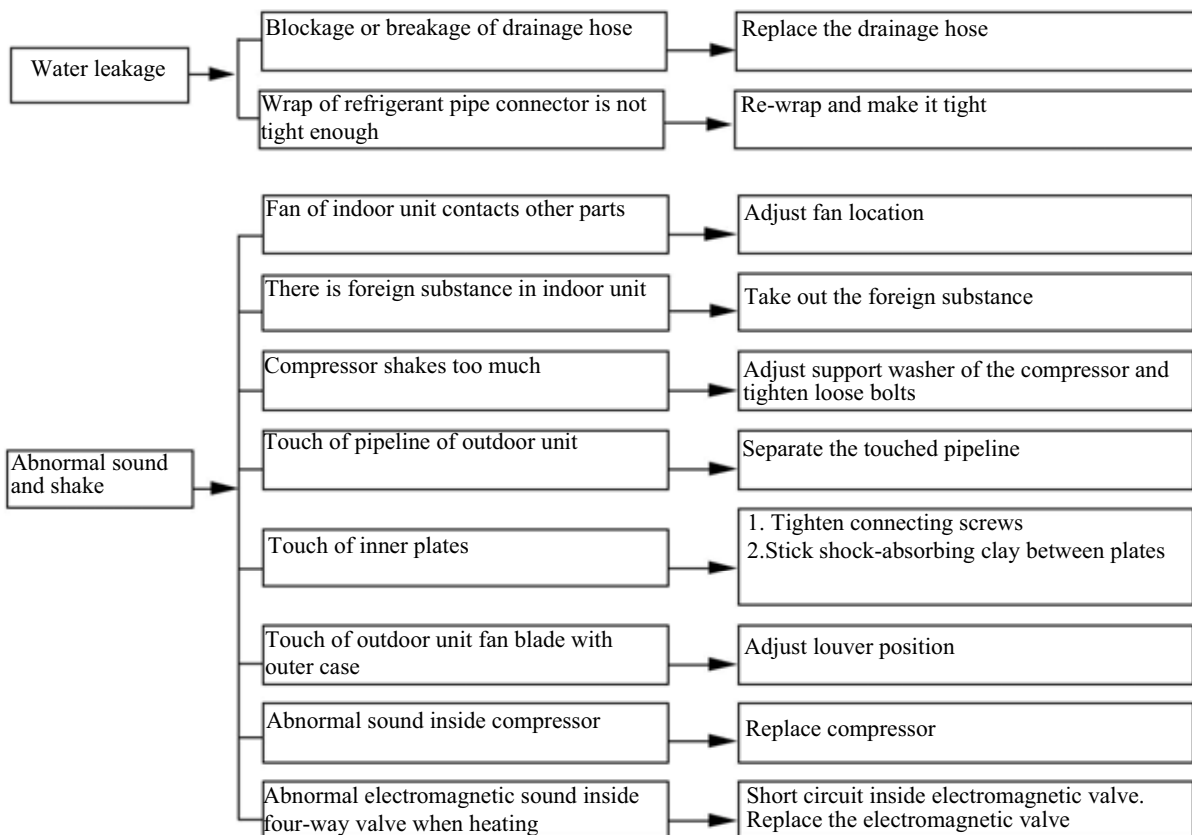

**Notes:**

1. When repairing, before the voltage between module PN is measured below 50V, do not touch any terminal to avoid electric shock.
2. When replacing power module and rectifier, be sure to spread the radiating paste evenly.

## 12.2 Malfunction display section

### Linge Wind D.C. Variable Frequency Series

When malfunction or protection occurs in the air conditioner, corresponding code will be displayed on the screen of the indoor unit and the indicator of outdoor unit will blink accordingly as well. When protection or malfunction is eliminated, display will be back to normal

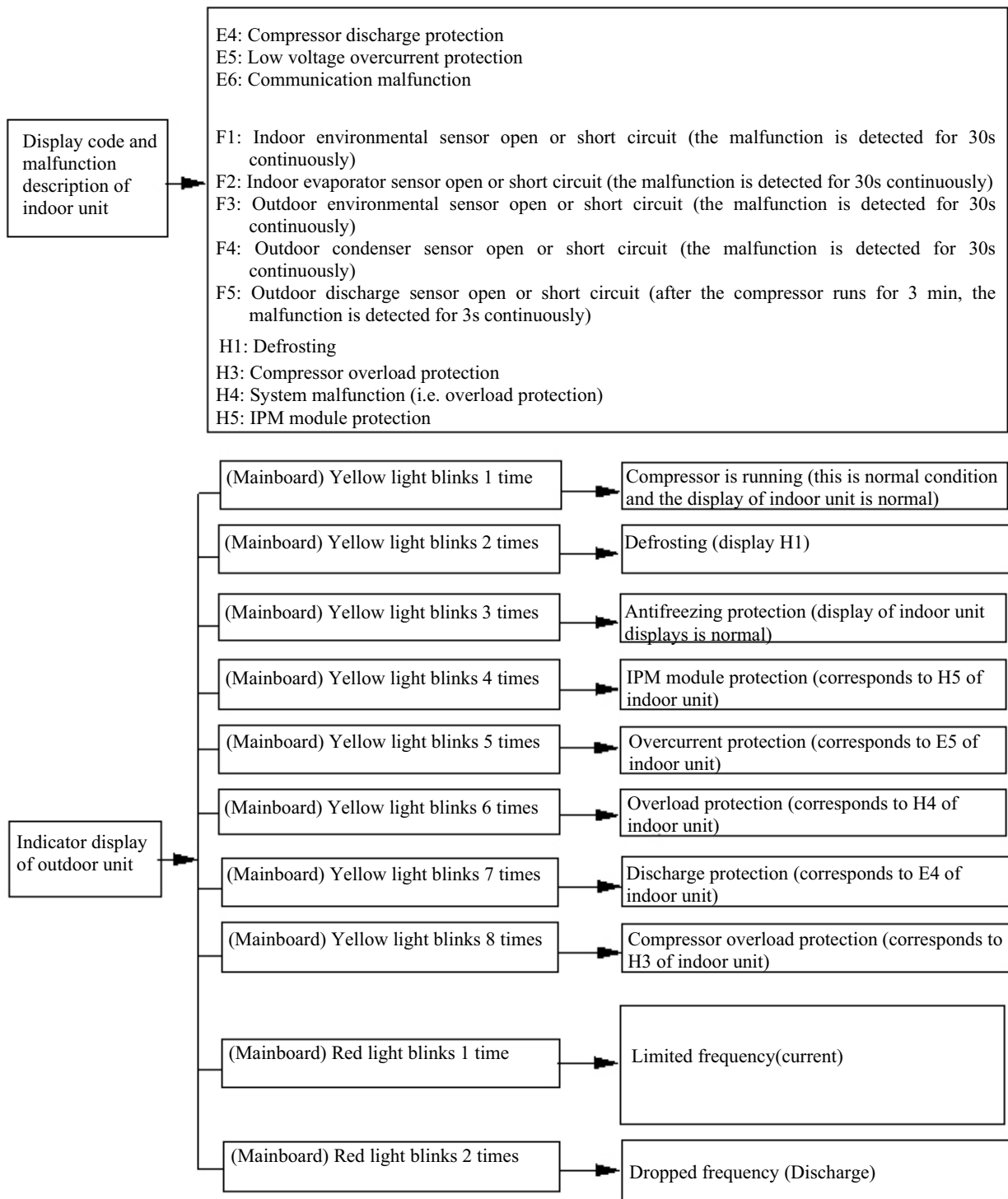

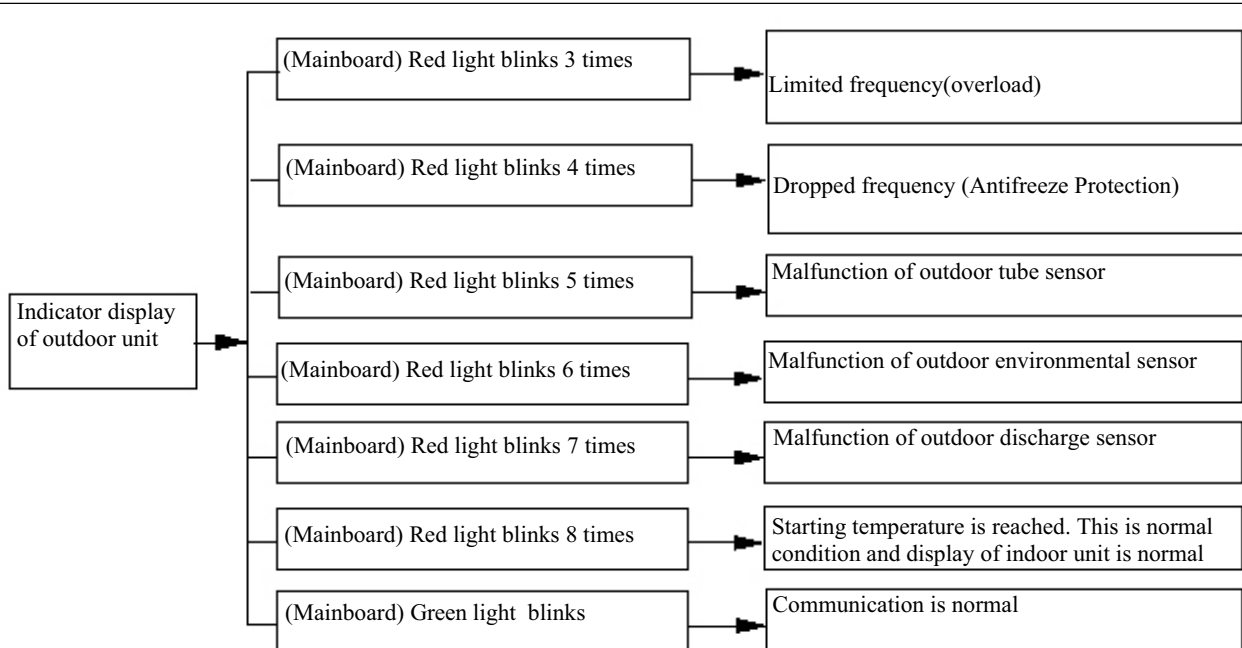

Note: Malfunction display : blind 0.5s; stop 0.5s, there is 2s' interval between two malfunction displays

Analysis or handling of some of the malfunction display:

1. Compressor discharge protection (E4):

Possible reasons: shortage of refrigerant; blockage of air filter; poor ventilation or air flow short pass for condenser; the system has noncondensing gas (such as air, water etc.); blockage of capillary assy (including filter); leakage inside four-way valve causes incorrect operation; malfunction of compressor; malfunction of protection relay; malfunction of discharge sensor; outdoor temperature too high.

Handling method: refer to the malfunction analysis in the above section.

2. Low voltage overcurrent protection (E5):

Possible reason: Sudden drop of supply voltage.

3. Communication malfunction (E6):

Handling method: Check if communication signal cable is connected reliably

4. Sensor open or short circuit (F1, F2, F3, F4, F5):

Handling method: Check whether sensor is normal, connected with the corresponding position on the controller and if damage of lead wire is found

5. Compressor overload protection (H3):

Possible reasons: insufficient or too much refrigerant; blockage of capillary and increase of suction temp.; improper running of compressor, burning in or stuck of bearing, damage of discharge valve; malfunction of protector.

Handling method: adjust refrigerant amount; replace the capillary; replace the compressor; use universal meter to check if the contactor of compressor is fine when it is not overheated, if not replace the protector.

6. System malfunction (H4):

i.e. overload protection. When tube temperature (Check the temperature of outdoor heat exchanger when cooling and check the temperature of indoor heat exchanger when heating) is too high, protection will be activated.

Possible reasons: Outdoor temperature is too high when cooling; insufficient outdoor air circulation; refrigerant flow malfunction.

please refer to the malfunction analysis in the previous section for handling method .

7. Module protection (H5):

Handling method:

