

# **Photovoltaic Charger**

**PCM4048/PCM6048**  
12/24/36/48 Vdc

## **User's Manual**

# Content

IMPORTANT NOTES .....	3
1.0 INTRODUCTION .....	4
1.1 INSTALLATION SITE .....	5
1.2 INSTALLATION .....	6
1.3 ACCESSORIES .....	7
1.4 LED INDICATION EXPLANATIONS .....	8
2.0 LCD DESCRIPTION .....	9
2.1 OPERATION.....	9
2.1.1Enter into Setting Mode .....	12
2.1.2Battery Capacity(AH) Setting .....	13
2.1.3Battery Voltage Setting.....	13
2.1.4 Battery Over-voltage Limit Setting.....	14
2.1.5 Battery Under-Voltage Limit Setting.....	15
2.1.6 Pulse Charge Setting .....	16
2.1.7 Parallel Address Setting .....	16
2.1.8 Total Input Power(KWH)Setting: .....	16
2.1.9 Parameters Displayed.....	17
2.2 LCD DISPLAY EXPLANATIONS .....	17
2.3 ERROR CODES .....	19
3.0 PRODUCT SPECIFICATIONS.....	20

## **Important Notes**

1. Keep this user's manual and follow all instructions indicated in the manual.
2. Don't overload the charger.
3. Don't split the charger apart; otherwise, your warranty is void.
4. Only authorized technician may repair or replace the interior components.
5. Make sure the ground of the load is connected properly. Otherwise, you may get electrical shock.
6. Keep the PV charger clean and dry.
7. Make sure all the contacts with correct polarity to avoid from short circuit.
8. Following the instruction of the user's manual to use or configure the charger.



## 1.0 Introduction

PCM4048/PCM6048 photovoltaic charger is to convert the energy from solar panel to load or batteries connected. With different load or batteries connected, it can be set as 12V, 24V, 36V or 48V system. The solar charger can get max. efficiency up to 95%. The solar cells can get the highest efficiency by means of Maximum Power Point Tracking(MPPT) and pulse charge method.. Via LCD display, it is easy to get input voltage/current, output voltage, battery temperature(with battery temperature compensation feature)...etc.. Through RS232 communication port, our monitoring software may provide output voltage setting or record all relative parameters from the PV charger.



**Figure 1: The front view of the PV charger**

Standard features of the PV Charger:

- Maximum Power Point Tracking(MPPT) maximizes energy harvest from the PV array.
- Auto-selection Four-stage (Bulk/Pulse/Float1/Float2) charge mode to reduce 1~3 times charge time and maximize system performance.
- Easy-to-read LCD and four functional key pads for configuration and system monitoring.
- Maximum efficiency up to 95%.
- Input over-voltage and under-voltage protection, output over-current protection and back-feed protection with warning messages appeared on LCD and LED.
- Over-temperature protection and power derating when output power and ambient temperature are high.
- Battery temperature sensor automatically provides temperature compensated battery charging.
- Provide communication software to monitor the status of the charger.

- Smart fan speed Control according to the load connected.
- This intelligent charger may set output voltage automatically or user may select output voltage 12/ 24 /36/ 48 V via LCD panel.
- Allow multi devices in parallel.

### 1.1 Installation Site

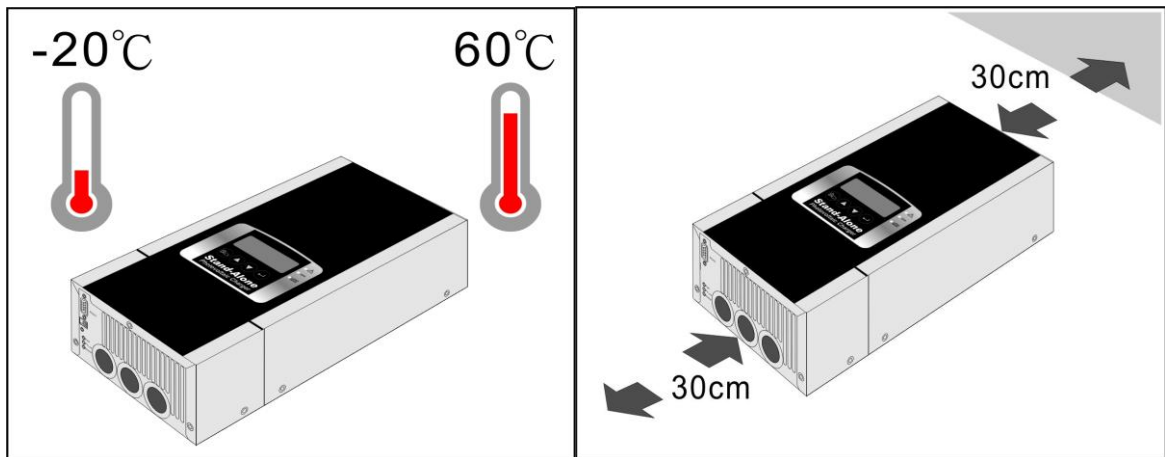

**Figure 2: Installation Environment**

#### **⚠ Notice!**

1. Inspect the charger upon receipt. This product is designed to be with robust packaging. However, accidents and damage may occur during transportation. Notify the forwarder or dealer if there is damage occurred. The packaging is recyclable; save it for reuse or dispose of it properly.
2. It is designed to be installed and commissioned in a sheltered controlled environment as follows:
  - Operating temperature -20°C ~60°C.
  - Always avoid from contact with direct sunlight.
  - Install it away from objects that give off excessive heat and areas that are excessively wet.
  - Install it indoors as it is not designed for installation outdoors.

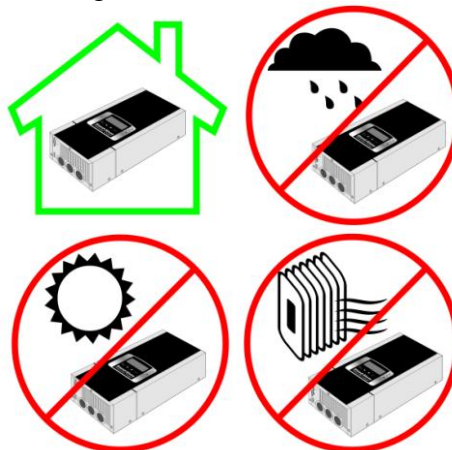

**Figure 3: Installation Site**

## 1.2 Installation

Please remove the wiring compartment cover for installation as illustrated below. After installation, please fasten the cover back to its original position.

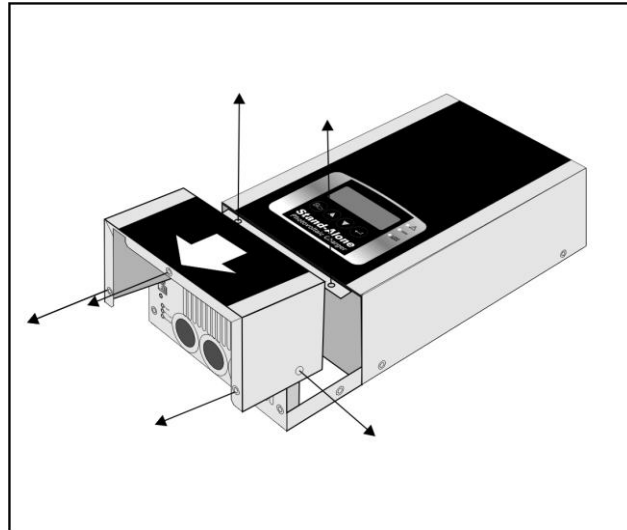

**Figure 4: Disassemble Wiring Compartment Cover**

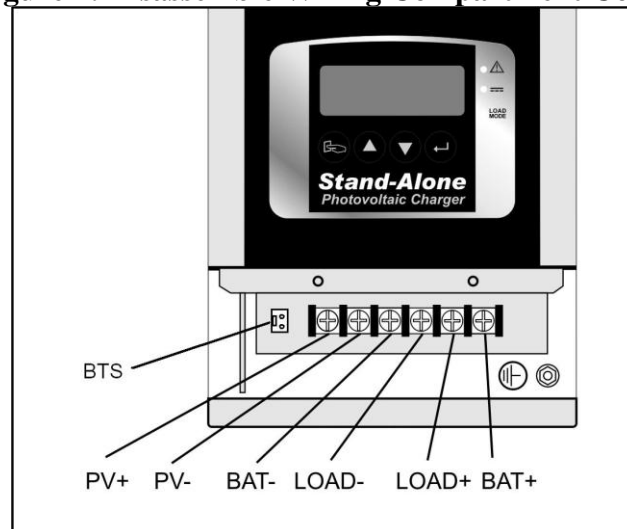

**Figure 5: Cabling**

Contact Description	
PV+	To the positive(+) of solar cell
PV-	To negative(-) of solar cell
Bat+	To the positive(+) of Bat. input
Bat-	To the negative(-) of Bat. input
Load+	To the positive(+) of Load
Load-	To the negative(-) of Load
BTS	Battery Temperature Sensor
	Ground

■Recommended Installation Sequence:

Connect Load → Battery → Solar Cell

■If there is no load connected

Connect Battery → Solar Cell

■Make sure the BTS wire is installed and fixed to the contact (CN11).

■Make sure the Battery and load are removed before entering into setting mode.

Mode	Description	Remarks
Load Mode	Output without connecting with battery.	Output voltage via LCD panel is required to be set..
Charging Mode	Output connecting battery or connecting both battery and load.	Output voltage via LCD panel can be fixed or auto set.

 **Caution!**

1. Make sure all cables are connected properly without short-circuiting.
2. There is 100A fuse inside the (BAT+).
3. Disconnect the Battery if there is no solar cell and load connected or if the solar cell is sheltered for a long while.
4. Do not overload the charger! Please refer to specification sheet to use the charger properly.
5. Make sure the voltage and capacity of the Battery is set correctly. Re battery setting, please refer to 2.1 Operation
6. Make sure the bat. Temperature compensation wire is installed and fixed where the battery is installed, not in the internal of the battery. Make sure the adhesive use is easy to conduct heat, so as to make sure the accuracy of the temperature compensation of the unit.

### 1.3 Accessories

1. Battery Compensation wire(BST) × 1

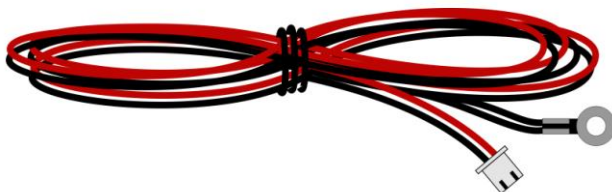

2. Connecting terminal to the solar panel(phi4-male) × 1

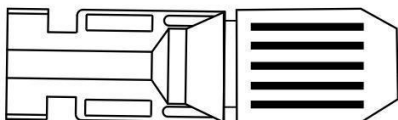

3. Connecting terminal to the solar panel(phi4-female) × 1

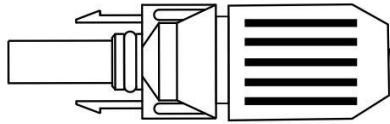

### 1.4 LED Indication Explanations

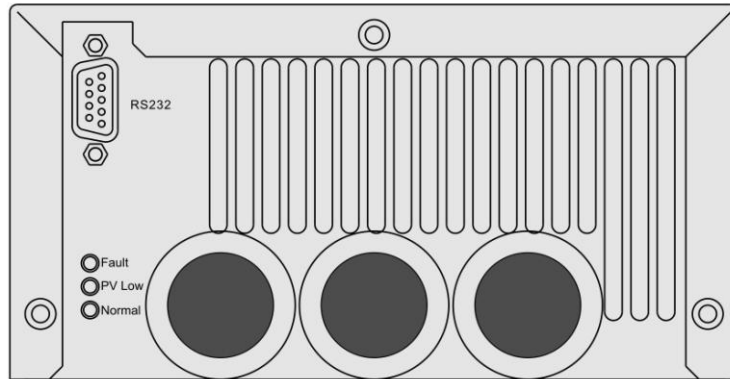
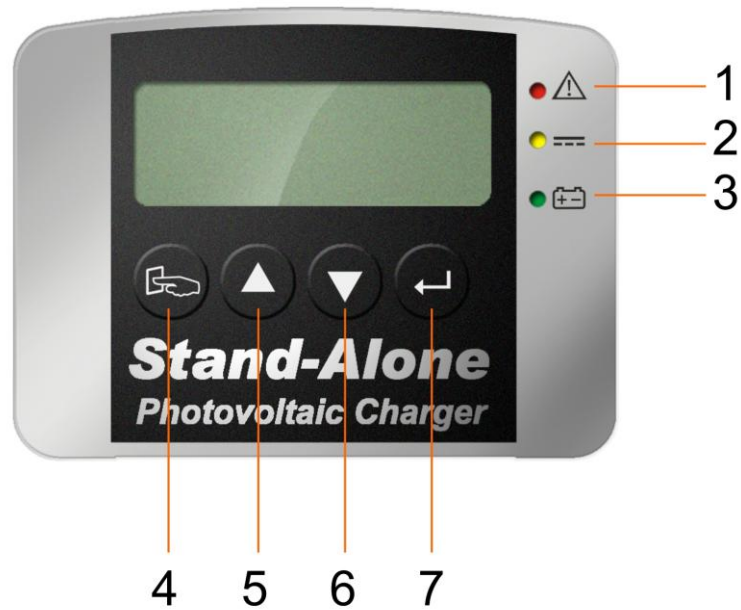

**Figure 6: Bottom View**

LED	Description
Fault (Red)	System Fault, Protection Circuit is activated.
PV Low (Amber)	Under-voltage/Over-voltage of Solar Cell
Normal (Green)	System Operation in Normal
RS232	RS232 Communication Interface



## 2.0 LCD Description



Item	Symbol	Description
1		System Fault, Charger goes to “Protection Mode” Error code shown on the LCD
2		Under-voltage/Over-voltage of Solar Cell
3		Charging Mode –Illuminate / Load Mode - Flash
4		Function Key (Left: push slightly; Return: push heavily)
5		Scroll Key-Up
6		Scroll Key-Down
7		Function Key (Right: push slightly; Enter: push heavily)

## 2.1 Operation

When the charger starts up normally, all the LED indicators will light up and the LCD display will show as drawing A.



**A**

Approx. 3 seconds later, the LCD display will show as drawing B and the charger is under initialization.

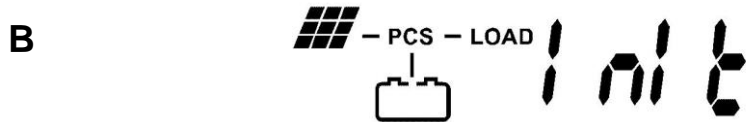

When the charger is in normal operation, it shows the current input voltage of the solar panel as shown in drawing C, then the green LED lights up to indicate that the charger is connected with batteries and also charges to the batteries. On the contrary, it shows that there are no batteries connected when the green LED is blinking and the output voltage is fixed.

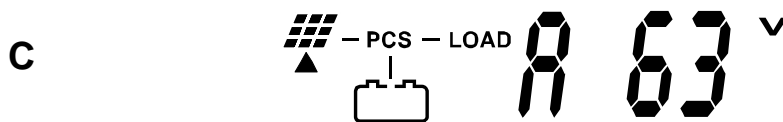

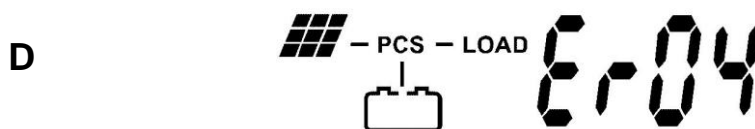

If there is a defect occurred during operation, the LCD display shows Er04 as shown below. For more detailed error code, please refer to Table 1 Error Code.

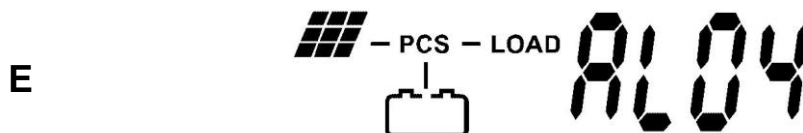

If there is over-voltage or under-voltage occurred during operation, the LCD display will show Alarm code as indicated below and the Amber LED lights up.





Press  key to indicate the parallel address of the charger as shown as drawing F and

press  key once again or wait for 10 seconds to go back to Main Menu.



F









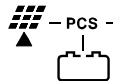

1 0 8

After turning on the PV charger, it will display current solar cells' voltage. If you would

like to see other parameters, you may press  key or  key.

Caution:  keys are of no use.

You may press  or  key to scroll up and down to get different display information and message.

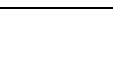
Display	Description
 - PCS - LOAD <b>A 63</b> <sup>v</sup>	Input Voltage of Solar Panel
 - PCS - LOAD <b>A00</b> <sup>A</sup>	Input Current of Solar Panel
 - PCS - LOAD <b>A000</b> <sup>KW</sup>	Input Power of Solar Panel
 - PCS - LOAD <b>800</b> <sup>KWH</sup>	Total input Power of Solar Cells
 - PCS - LOAD <b>11.9</b> <sup>v</sup>	Battery Voltage
 - PCS - LOAD <b>0.0</b> <sup>A</sup>	Current supplied to batteries
 - PCS - LOAD <b>100</b> <sup>AH</sup>	Current battery capacity set
 - PCS - LOAD <b>6 20</b> <sup>°C</sup>	Battery Temperature(°C)
 - PCS - LOAD <b>H 40</b> <sup>°C</sup>	IGBT Temperature(°C)
 - PCS - LOAD <b>6 4</b> <sup>°F</sup>	Battery Temperature(°F)
 - PCS - LOAD <b>H 12</b> <sup>°F</sup>	IGBT Temperature(°F)



## 2.1.1 Enter into Setting Mode



Make sure the output voltage and capacity of the battery are set properly.

### **⚠ Caution!**













Before entering into setting mode, make sure the battery and the load are removed; otherwise, it might damage the battery and the load due to improper setting.

Step1: Make sure the charger is connected with solar cell with 40V~150Vdc voltage and do not turn on the charge.

Step2: Press  and  simultaneously, then turn on the charger. You may see the three LEDs on the front panel will light up and extinguish after 3 second. Then, “AH” text will be indicated on the LCD display, which means the charger is in setting mode now. If no “AH” text shown on the LCD, you need to repeat Step 2.

Step3: Press  or  to choose item to be set. Basically, you may set Battery Capacity(AH), Battery Voltage(BATT), Battery High Limit (BAUP), Battery Low Limit(BADW), Pulse Mode Setting(PULS), ID(ID), and total input power(KWH).



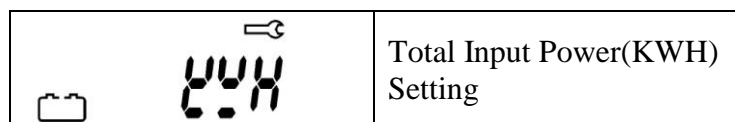

Press  to go to the desired item.

Display	Description
  AH	Battery Capacity Setting
  BATT	Battery Voltage Setting
  BAUP	Battery Over-voltage Setting
  BADW	Battery Under-voltage Setting
  PULS	Pulse Charge Setting
  ID	Parallel Address Setting



### 2.1.2 Battery Capacity(AH) Setting

Step1: It indicates the current battery capacity when getting into Battery Capacity setting.

Step2: Select desired battery capacity (AH) by scroll  key or  key. The digit with flashing cursor means the desired one to be changed. If you would like to change the left-hand/right-hand digit, you may press  key or  key respectively.

Step3: Battery Capacity(AH) is selectable from 1~999AH. When the desired capacity(AH) is selected, please press  key to save till “SAVE” shown on the screen. When “SAVE” disappears on the screen, it means your setting is done successfully.

Step4: To escape from Battery Capacity(AH) setting, please press  key for a while.



Caution: If there is ER39 shown on the LCD display after the setting is completed and a re-starting process is done, it means your setting is failed. Please proceed desired setting once again.

### 2.1.3 Battery Voltage Setting

The selectable battery voltage settings are 12V, 24V, 36V, 48V or auto. The charger will check the selected voltage matched to the batteries connected. In case it is out of acceptable range, it will show it as battery out of order. Meanwhile, the user can self set battery under-voltage and battery over-voltage. When the AUTO setting is selected, the voltage window will be as below:

Battery Voltage	Auto Detecting Voltage Range	Self-Setting Voltage Range(default)
48V	44~56V	42~54.6V
36V	33~42V	28~40.9V
24V	22~28V	18~27.3V
12V	11~14V	9~13.6V

Step1: When enter into Battery Voltage setting, current battery voltage will be shown on the LCD display.

Step2: To select other battery voltage by scrolling  key and  key.

Step3: Battery voltage can be set as 12V, 24V, 36V, 48V or Auto. When the desired voltage is selected, please press  key to save till “SAVE” shown on the screen. When “SAVE” disappears on the screen, it means your setting is done successfully.

Step4: To escape from Battery Voltage Setting, please press  for a while.

Caution: If there is ER39 shown on the LCD display after the setting is completed and a re-starting process is done, it means your setting is failed. Please proceed desired setting once again.





### 2.1.4 Battery Over-voltage Limit Setting

In normal condition, it is not necessary to calibrate this setting as long as the battery voltage selected is within window. For example, if the user selects 24V, the default over-voltage is 27.3V. In case the battery voltage desired is higher than this voltage, you may calibrate battery voltage to be higher. The setting procedure is as below:

#### **Caution!**

In normal condition, it is not necessary to calibrate this setting. Before processing the setting, make sure the battery voltage setting is done properly to avoid damaging battery or load.

Step1: When entering into Battery Over-voltage setting, it shows the current battery over-voltage.

Step2: In case of any other desired voltage, please press  key or  key to choose the figure you prefer. The figure with blinking means the current place you are. To change the figure at left-hand side, please press  key, on the contrary, you may press  key to change the right-hand side.

Step3: After the battery over-voltage is selected, please press  key to save till “SAVE” shown on the screen. When “SAVE” disappears on the screen, it means your setting is done successfully.

Step4: If you would like to escape from battery over- and under- voltage setting, please press  key to escape.





### 2.1.5 Battery Under-Voltage Limit Setting

In normal condition, it is not necessary to calibrate this setting as long as the battery voltage selected is within window. For example, if the user selects 24V, the default under-voltage is 18V. In case the battery voltage desired is lower than this voltage, you may calibrate battery voltage to be lower. The setting procedure is as below:

#### **Caution!**

In normal condition, it is not necessary to calibrate this setting. Before processing the setting, make sure the battery voltage setting is done properly to avoid damaging battery or load.

Step1: When entering into Battery Over-voltage setting, it shows the current battery under-voltage.

Step2: In case of any other desired voltage, please press  key or  key to choose the figure you prefer. The figure with blinking means the current place you are. To change the figure at left-hand side, please press  key, on the contrary, you may press  key to change the right-hand side.



Step3: After the battery under-voltage is selected, please press  key till “SAVE” shown on the screen new parameter. If the “SAVE” extinguishes from the screen and show “OVER” instead. It means the voltage selected is higher than the battery’s over-voltage.

Step4: If you would like to escape from battery over- and under- voltage setting, please press  key to escape.

### 2.1.6 Pulse Charge Setting

It is to set if the charger can be in pulse charge. Basically, the charger is set at Pulse Charge setting as default. Setting procedure is as below:

Step1: Step1: Enter into Pulse Charge Setting. If it shows “ON” it means the charger is able to be in Pulse Charge; on the contrary, it means the charger is not able to be in Pulse Charge if it shows “OFF”.





Step2: You may select “ON” or “OFF” by pressing  key or  key, then press  key to save till “SAVE” shown on the screen. When “SAVE” disappears on the screen, it means your setting is done successfully.

Step3: You may escape from this setting by pressing  key.

### 2.1.7 Parallel Address Setting

When there are several chargers in parallel, you may proceed the setting as below:

Step1: Enter to Parallel Address Setting, then the charger will show the address of the charger in parallel.

Step2: To select other desired parallel address, you may press  key or  key to choose the figure you prefer. The figure with blinking means the current place you are. To change the figure at left-hand side, please press  key, on the contrary, you may press  key to change the right-hand side.

Step3: The selectable range of the parallel address is 1~254. When the desired parallel address is selected, please press  key to save till “SAVE” shown on the screen. When “SAVE” disappears on the screen, it means your setting is done successfully.





Step4: You may escape from this setting by pressing  key



### 2.1.8 Total Input Power(KWH)Setting:

To set the initial value of the total input power(KWH), user may set the total input power to “zero” or “certain value”. The setting method is as below:





Step1: Enter into total input power setting, it shows "0000".

Step2: If you would like to set other initial value, you may use  key or  key to select desired value. When the figure selected is blinking, it means the figure that you may change. "K" at the right-hand side means "1000"times, so if the screen shows 123K means 123000 KWH. If you would like to change the left-hand figure, you may press  key and the right-hand figure, you may press  key.

Step3: The range of the total input power can be selected from 0~999K KWH. Once the figure is selected, you may press  key to save. Make sure the "SAVE" shown on the screen, then you may release  key now. When "SAVE" disappears on the screen, it means your "save" is done successfully.

Step4: You may escape from this setting by pressing  key



### 2.1.9 Parameters Displayed



























Step1: After turning on the PV charger, it will display current solar cells' voltage. If you would like to see other parameters, you may press  key or  key.



Step2: The LCD can show the following data, such as the voltage of the solar cells, the input voltage/current of the solar cells, the input power of the solar cells, battery voltage/current, Battery Capacity set(AH), charger temperature and battery temperature.

Caution:  keys are of no use.

### 2.2 LCD Display Explanations

Display	Description
	Input Voltage from Solar Cells
	Input Current from Solar Cells

 - PCS - LOAD  <b>8000</b> KW	Input Power from Solar Cells
 - PCS - LOAD  <b>800</b> KWH	Total Input Power of the solar Cells
 - PCS - LOAD  <b>11.9</b> V	Battery Voltage
 - PCS - LOAD  <b>0.0</b> A	Current supplied to Battery
 - PCS - LOAD  <b>100</b> AH	Current Battery Capacity Setting
 - PCS - LOAD  <b>C-40</b> °C	Battery Temperature in Celsius
 - PCS - LOAD  <b>H-40</b> °C	IGBT temperature in Celsius
 - PCS - LOAD  <b>C 12</b> °F	Battery Temperature in Fahrenheit
 - PCS - LOAD  <b>H 12</b> °F	IGBT temperature in Fahrenheit
 <b>AH</b>	Battery Capacity Setting Directory
 <b>bAtt</b>	Battery Voltage Setting Directory
 <b>bAvP</b>	Battery Over-voltage Setting
 <b>bAdV</b>	Battery Under-voltage Setting
 <b>PULS</b>	Pulse Charge Setting
 <b>1d</b>	Parallel Address Setting
 <b>24H</b>	Total Input Power(KWH) Setting
 <b>100</b> AH	Battery Capacity configuration

	Battery Voltage configuration
	New parameters set are under saving.

### 2.3 Error Codes

When the charger can not work normally, it will show the error code on the LCD display as Table 1. You may proceed troubleshooting indicated as below.

Error Code	Description	Trouble Shooting
AL04	Input Over-voltage	Reduce input voltage
AL05	Input Under-voltage	Increase input voltage
ER04	Battery Voltage different from Setting	Ensure battery voltage and proceed setting
ER11	Input over power	Decrease solar power (Watt) or reduce load connected
ER13	Output Short Circuit	Check to see if the output short circuit is removed.
ER17	EEPROM Error	Consult with your local agent
ER18	Over-heat	Reduce the ambient temperature and reduce load connected.
ER25	Input Over-current	Decrease solar power(Watt) or reduce load connected.
ER28	Output Voltage too high	Re-start the charger
ER32	Memory Error	Re-start the charger
ER33	Charger is self-locked	Check to see if the operation condition is complied with what the charger requires.
ER34	Crystal damage	Consult with your local agent
ER35	Output voltage too low	The charger will be automatically re-start after 15 seconds.
ER36	Bat. Over-heat	Reduce the environmental temperature of the battery
ER37	Fan out of order	Check to see if fan is blocked.
ER38	AUTO Function Enable	Reset the output voltage manually
ER39	Failure in "save"	Re-setting

Table 1 Error Code

 **Caution!**

Before any troubleshooting is on process, make sure the solar panels and batteries are disconnected. If the error code still exists, please consult with your local agent.

### 3.0 Product Specifications

Models	PCM4048	PCM6048
<b>Input</b>		
Rated Voltage	40~120Vdc	
Operating Voltage / MPPT Range	40~120 Vdc @ 12Vbat 40~120 Vdc @ 24Vbat 50~120 Vdc @ 36Vbat 60~120 Vdc @ 48Vbat	
Max. Input current	25 A	35 A
Max. PV Array Open Circuit Voltage	150 Vdc	
Max. PV Array Power	1000W	1500W
<b>Output</b>		
Battery Voltage	12 / 24 / 36 / 48Vdc	
Max. Charger / Output Current	40 A	60 A
Ripple Voltage	< $\pm 1V$	
Max. Efficiency	95%	
Charge regulation modes	Bulk / Pulse / Float1/Float2 or Bulk / Float1/Float2	
<b>Display</b>		
Status on LCD	Solar Cell Input Voltage / Solar Cell Input Current/Solar Cell Input Power /Bat. Voltage /Bat. Current /Bat. AH/ IGBT temperature /Bat. temperature/ Voltage setting table, etc.	
Status on LED	Normal/Fault/PV Low	
<b>Protection</b>		
Overload	>110% shutdown	>105% shutdown
Short Circuit at load side	Output current>60A shutdown	
Solar Cell Polarity Error Protection	Yes	
Battery Temperature Compensation	-3.3mV/°C/cell	
Standby Power Consumption	0 W	
Total Power Consumption While Operating	3.5 W	
<b>Alarms</b>		
Visible	Fault, PV Low, Bat. Abnormal, etc.	
<b>PHYSICALS CHARACTERISTICS</b>		
Mechanical Dimensions WxHxD mm	165x85x330 mm (2U height)	
Input/Output Connectors	Hardwire(Terminal Block)	
Enclosure Type	IP20	

Net Weight (Kgs)	3.2 Kgs
ENVIRONMENT	
Operating Temperature	-20°C to +60°C
Storage Temperature	-40°C to +85°C
Altitude	0-2000M up to 60°C; 0~3000M up to 55°C
Humidity	100% RH Maximum, No Condensing
INTERFACE COMPUTER	
Type	Standard RS232
COMPLIANCE	
Quality	ISO9001
Standard EMC	EN61000-6-1, EN61000-6-3
Marking	CE
Patent Pending	
Part No.	Taiwan: 97147246
	China: 200810180491.7
	USA: 12/273,669





192321452000000