



**MODEL SPEC-150 RADIOGRAPHY EXPOSURE DEVICE
AND
ASSOCIATED EQUIPMENT**

**USER'S MANUAL
Revision (10)
November 1, 2011**

**Source Production & Equipment Co., Inc.
113 Teal Street
St. Rose, Louisiana 70087 USA
www.spec150.com**

TABLE OF CONTENTS

- 1.0 GENERAL INFORMATION
 - 1.1 Description
 - 1.2 Safety Analysis
 - 1.3 Quality Assurance
 - 1.4 G-60 Source Classification
 - 1.5 User Qualification Requirements
 - 1.6 Authorized Associated Equipment
 - 1.7 Safety Precautions
 - 1.8 Items Accompanying the Exposure Device
 - 1.9 Abbreviations
 - 1.10 Warranty and Limitation of Liability

- 2.0 DESCRIPTION
 - 2.1 SPEC-150 Exposure Device
 - 2.1.1 Exposure Device Key
 - 2.1.2 Device and Component Drawings
 - 2.1.3 Labeling and Marking
 - 2.1.4 Materials of Construction
 - 2.2 Control Assembly
 - 2.2.1 Control Assembly Lengths and Materials
 - 2.2.2 Control Assembly Operation
 - 2.2.3 Control Assembly Adaptor
 - 2.2.4 Control Assembly Drive Cable and Connector
 - 2.3 Guide Tubes

- 3.0 GENERAL CONDITIONS OF USE
 - 3.1 Intended Use
 - 3.2 Environmental Conditions of Use
 - 3.3 Installation
 - 3.4 Basic Operation
 - 3.5 Occasions for Persons to be Near the Device
 - 3.6 Special Equipment Use

- 4.0 MECHANICAL SAFETY FEATURES OF THE DEVICE
 - 4.1 Exposure Device Lock
 - 4.2 Source Assembly Lock
 - 4.3 Automatic Securing Mechanism (ASM)
 - 4.4 ASM/Lock Module
 - 4.5 No Visual "Source Position" Indicator
 - 4.6 Source Assembly Misconnect Protection
 - 4.7 Lock Cap
 - 4.8 Safety Plug
 - 4.9 Error-Free Design

- 4.10 Lubrication-Free Design
- 4.11 Carrying Handle & Tie-Down Holes
- 4.12 Protection from Unauthorized Access

- 5.0 RADIATION SAFETY FEATURES
 - 5.1 External Radiation Levels
 - 5.2 Protection from Scattered Radiation
 - 5.3 Protection from DU Contamination

- 6.0 SPEC-150 SYSTEM OPERATING PROCEDURES
 - 6.1 Safety Precautions
 - 6.1.1 Survey Instrument
 - 6.1.2 Personnel Training and Supervision
 - 6.1.3 Personnel Monitoring
 - 6.1.4 Protection from Direct Radiation
 - 6.1.5 Protection from Scattered Radiation
 - 6.2 SPEC-150 Radiography System Set-Up Procedures
 - 6.3 SPEC-150 Radiography System Operation Procedures
 - 6.4 SPEC-150 Radiography System Break-Down Procedures
 - 6.5 Emergency Response Procedures
 - 6.5.1 Equipment Malfunctions and Accidents
 - 6.5.2 Fire
 - 6.5.3 Lost or Stolen Source

- 7.0 **SPEC-150 SAFETY INSPECTION PROCEDURES**
 - 7.1 Daily Safety Inspection Procedure
 - 7.1.1 Survey Instrument
 - 7.1.2 SPEC-150 Exposure Device
 - 7.1.3 Source Assembly Connector
 - 7.1.4 Control Assembly
 - 7.1.5 Pistol Grip Daily Inspection
 - 7.1.6 Drive Cable
 - 7.1.7 Drive Cable Connector
 - 7.1.8 Control Assembly Adaptor
 - 7.1.9 Guide Tube Daily Inspection
 - 7.2 Quarterly Safety Inspection Procedures
 - 7.2.1 Survey Instrument
 - 7.2.2 SPEC-150 Exposure Device
 - 7.2.3 G-60 Source Assembly Connector
 - 7.2.4 Control Assembly
 - 7.2.5 Guide Tube Quarterly Inspection
 - 7.2.6 SPEC-150 System Operational Check

- 8.0 SPEC-150 MAINTENANCE AND REPAIR PROCEDURES
 - 8.1 General
 - 8.2 Recommended Replacement Components

- 8.3 Modifying, Repairing or Tampering with the Device
 - 8.4 SPEC-150 Exposure Device
 - 8.5 ASM/Lock Module
 - 8.5.1 ASM/Lock Module Removal
 - 8.5.2 ASM / Lock Module Installation
 - 8.6 Outlet Panel Assembly
 - 8.6.1 Outlet Panel Assembly Replacement Procedures
 - 8.7 Lock Cap, Safety Plug, Key and Control Adaptor
 - 8.8 Radiation Profile Survey Procedures
 - 8.9 G-60 Source Assembly
 - 8.10 Control Assembly / Drive Cable Maintenance and Repair
 - 8.10.1 Control Assembly Disassembly
 - 8.10.2 Control Assembly Internal Component Inspection
 - 8.10.3 Control Assembly Cleaning Procedures
 - 8.10.4 Drive Cable Maintenance and Cleaning Procedure
 - 8.10.4 Control Re-assembly Procedure
 - 8.11 Guide Tube
- 9.0 TRANSPORTATION PREPARATIONS
- 9.1 Procedures for Preparing and Loading the Package
 - 9.1.1 General Package Inspection
 - 9.1.2 Packaging
 - 9.1.3 Outer Package Surface Contamination
 - 9.1.4 Transportation Requirements
 - 9.1.5 Type B Quantity Consignee Notification
 - 9.2 Procedures for Receipt and Unloading the Package
 - 9.2.1 Unloading the SPEC-150
 - 9.2.2 Receiving the SPEC-150
 - 9.3 Preparation of an Empty Package for Transport

1.0 GENERAL INFORMATION

1.1 Description

The SPEC-150 is a portable, ANSI Type 1, depleted uranium shielded exposure device used for industrial gamma radiography nondestructive testing applications. The SPEC-150 radiography system consists of the SPEC-150 exposure device, a model G-60 source assembly and associated equipment. This equipment includes a manual remote control assembly, guide tube and collimator. The G-60 is an Iridium-192 radioactive sealed source with a maximum activity of 150 curies (5550 GBq). The control assembly is used to move the source out of the exposure device and into the guide tube to perform radiography. The collimator provides radiation shielding at the end of the guide tube.

1.2 Safety Analysis

The model SPEC-150 exposure device, model G-60 source, and associated equipment meet the requirements specified in ANSI N432-1980 "Radiological Safety for the Design and Construction of Apparatus for Gamma Radiography," and 10 CFR Part 34.20 "Performance Requirements for Radiography Equipment." The SPEC-150 System is approved by the Louisiana Radiation Protection Division and the United States Nuclear Regulatory Commission (certificate number USA/9263/B(U)-96). A Registry Sheet is available upon request.

1.3 Quality Assurance

The SPEC-150 exposure device is manufactured under the control of the SPEC Quality Assurance Program. SPEC has been issued Quality Assurance Program Approval for Radioactive Material Packages Number 0102 by the U.S. Nuclear Regulatory Commission. The Quality Assurance Program controls the design, fabrication, assembly, testing, use, maintenance and repair of radioactive material packages, exposure devices, sources and associated equipment.

1.4 G-60 Source Classification

The model G-60 source meets ANSI N542 classification 77C43515. The source meets U.S. Department of Transportation 10 CFR Part 34, 49 CFR, and International Atomic Energy Agency (IAEA) requirements for Special Form Radioactive Material. It is authorized for transport under IAEA Certificate of Competent Authority for Special Form Radioactive Materials Certificate Number USA/0608/S. The G-60 source is approved by the Louisiana Radiation Protection Division. A Registry Sheet is available upon request.

1.5 User Qualification Requirements

Users are required to be specifically licensed by the Nuclear Regulatory Commission or an Agreement State to use the SPEC-150 in the United States. National regulations may apply in other countries. Radiography workers must be formally trained and qualified in the safe use of the SPEC-150 system, survey instruments, and general radiation safety. They must be specifically authorized by the licensee to use the SPEC-150. The SPEC-150 must be used in

strict compliance with licensee Operating and Emergency Procedures, applicable safety regulations, and all operation, inspection and maintenance instructions in this manual.

1.6 Authorized Associated Equipment

The SPEC-150 is authorized for use with approved control assemblies, flexible "Yellow" guide tubes, rigid "J" tubes and collimators that are designed, tested, manufactured and inspected by SPEC in accordance with 10 CFR Part 34.20 regulations. Replacement sources and associated equipment manufactured by other authorized manufacturing companies may be tested and submitted for approval for use with the SPEC-150 exposure device. Licensees should consult with the applicable NRC or Agreement State licensing agency to determine if specific authority is required to use custom-made associated equipment such as extra length guide tubes or remote unsecuring mechanism (RUM).

1.7 Safety Precautions

The SPEC-150 must be used only by authorized and monitored individuals who have been formally trained in the use of this device, the proper use of survey instruments, and general radiation safety. This device must be used in strict compliance with licensee operating and emergency procedures and all applicable government safety regulations to assure that exposure to workers and the public is maintained AS LOW AS REASONABLY ACHIEVABLE (ALARA) below established dose limits.

The SPEC-150 must be used with a calibrated and operable survey instrument at all times. THE USE OF OTHER DEVICES (SUCH AS ALARMING RATEMETERS, BEEPERS, SOURCE POSITION INDICATORS, AND AREA ALARMS) INSTEAD OF A SURVEY INSTRUMENT IS EXTREMELY DANGEROUS AND NEGLIGENT. Trainees, helpers and assistants must operate the device only under the direct visual surveillance of a qualified radiographer. It is recommended that licensees provide workers with NRC publication "Working Safely with Gamma Radiography" NUREG/BR-0024.

1.8 Items Accompanying the Exposure Device

1. SPEC-150 User's Manual
2. Model 1 Leak Test Kit and instructions.
3. Quality Assurance Final Inspection Certificate. The certificate includes a radiation profile report. It records the highest radiation levels extrapolated to 150 curies at the surface (not readings averaged over large areas), and at one meter from all six surfaces. It includes the radiation level at the outlet nipple when the safety plug is removed.
4. Optional SPEC-150 Annual Maintenance Program information flier.
5. 6 ea. White Tamper Resistant Seals

1.8a. ASM/Lock Module and Outlet Panel Assembly Replacement Tools

1. A set of special tools to remove the outlet panel assembly are provided with the new assembly.
2. A set of special tools are loaned with each spare ASM/Lock Module purchased and with each replacement ASM/Lock Module provided by SPEC under the conditions of the ASM Lock Module Maintenance Program.

1.9 Abbreviations

ANSI	American National Standards Institute
ASM	Automatic Securing Mechanism
ISO	International Organization for Standardization
IAEA	International Atomic Energy Agency
DU	Depleted Uranium
SPEC	Source Production & Equipment Co., Inc.
TMJ	SPEC Thermal Metal Joining Special Process

1.10 Warranty and Limitation of Liability

SPEC PRODUCT LIMITED WARRANTY

1. Source Production & Equipment Co., Inc. (SPEC) warrants that on the date the exposure device or source changer is sold, it will meet SPEC's standard specifications for exposure devices and source changers will be free of defects in material and manufacture. THIS WARRANTY APPLIES ONLY AGAINST DEFECTS AND NONCONFORMITIES THAT ARE DISCOVERED WITHIN ONE (1) YEAR FROM THE DATE OF FIRST SALE BY SPEC OR AN AUTHORIZED SPEC DEALER. ALL SPEC MANUFACTURED SOURCE ASSEMBLIES, ASSOCIATED EQUIPMENT AND REPLACEMENT PARTS OF RADIOGRAPHY SYSTEMS (E.G. CONTROL ASSEMBLIES, GUIDE TUBES, ASM/LOCK MODULE UNITS, CONTROL ADAPTORS, ETC.) AND ALL OTHER SPEC MANUFACTURED PRODUCTS ARE WARRANTED TO BE FREE OF DEFECTS AND NONCONFORMITIES FOR A PERIOD OF THIRTY (30) DAYS FROM THE DATE OF FIRST SALE. If the Buyer discovers the defects or nonconformities, Buyer must notify SPEC in writing, certified, and post marked within thirty (30) days after the date of discovery and in no event later than thirteen (13) months after the date of first sale for exposure devices and sixty (60) days for associated equipment to Attn: Sales Manager, 113 Teal Street, St. Rose, LA 70087.

SECTION OF LAW AND FORUM

2. The Buyer and SPEC hereby specifically agree that this sale shall be deemed consummated in the State of Louisiana. SPEC and Buyer hereby agree that the laws for the State of Louisiana will apply to this agreement in its interpretation and enforceability. In addition, SPEC and buyer agree that any controversy and/or litigation concerning the purchase of SPEC's product by Buyer shall be held and filed in a court of competent jurisdiction within the Parish of Jefferson, State of Louisiana.

DISCLAIMER OF WARRANTIES

3. Any Warranties of the product herein sold are only those provided by SPEC. SPEC hereby expressly disclaims all warranties, except those warranties which have been provided in the above section entitled "SPEC Product Limited Warranty". SPEC hereby expressly disclaims all or any other express or implied warranties, including any implied warranty of merchantability or fitness for a particular purpose. SPEC neither assumes nor authorizes any other person to assume for it any liability in connection with the sale of its product.

It is specifically understood between the buyer and SPEC, that this sale is made without any warranty not included within SPEC's express warranties (as provided above) except as to title. The buyer herein specifically waives the implied warranties provided for by Louisiana law and any other state law (should a court of competent jurisdiction not honor the parties selection of Louisiana law to govern its relations), including all warranties against vices or defects for any particular purpose. This express waiver shall be considered a material and integral part of this sale. There are no exceptions to the foregoing provision except as maybe expressed in writing by SPEC.

BUYER'S REMEDIES

4. If the exposure device fails to conform to the warranties in paragraph 1 and such nonconformity is not due to misuse or improper maintenance, Buyer shall notify SPEC as provided in paragraph 1, and within a reasonable time, SPEC shall provide at its option, one of the following:
 - 1) repair or replacement of any nonconforming or defective parts, or
 - 2) full refund of the purchase price or reduced refund based on age and use of equipment.THIS REMEDY SHALL BE THE EXCLUSIVE AND SOLE REMEDY OF BUYER FOR ANY BREACH OF WARRANTY.
5. Should any provision, aspect or term of this waiver of warranties be deemed unenforceable for any reasons, it is specifically agreed by SPEC and/or its product distributors and the buyer that the aspect, provision and/or term found unenforceable shall be severed from the agreement as a whole so the most limited extent necessary. All other aspects, terms, and provisions shall maintain their full force and effect.

EXCLUSION OF CONSEQUENTIAL AND INCIDENTAL DAMAGES

6. IN NO EVENT SHALL SPEC BE LIABLE FOR ANY INCIDENTAL, SPECIAL, INDIRECT, OR CONSEQUENTIAL DAMAGES, WHETHER RESULTING FROM NONDELIVERY OR FROM THE USE, MISUSE, OR INABILITY TO USE THE PRODUCT OR FROM DEFECTS IN THE PRODUCT OR FROM SPEC'S OWN NEGLIGENCE OR OTHER TORT. This exclusion applies regardless of whether such damages are sought for breach of warranty, breach of contract, negligence, or strict liability in tort or under any other legal theory.

EXCLUSION OF LIABILITIES

7. The purchaser of SPEC's product, by purchasing the product, attests to SPEC, its distributors and all other third parties that it is a knowledgeable, experienced and a sophisticated user of said product. Buyer hereby warrants that it fully understands the dangerous nature of the radioactive material together with the safety and regulatory requirements attendant to its use. Buyer hereby

warrants that it will use and maintain the purchased product in a manner which does not violate Nuclear Regulatory Commission or equivalent Agreement State license conditions and regulations imposed upon the licensee or worker regarding the safe use of the equipment.

8. The foregoing warranties and liabilities of SPEC and remedies of Buyer are exclusive, and Buyer waives and releases all other warranties, obligations, and liabilities of SPEC and all other remedies, claims, and rights of Buyer relating in any way to the equipment covered by this agreement, whether arising from contract, warranty, or tort or from negligence, tort, or other fault of SPEC, including claims for loss of or damage to the equipment. SPEC assumes no liability or responsibility for any damages or injuries, regardless of cause, resulting from the use of SPEC manufactured equipment, or resulting from the use of any radioactive material or associated equipment in a manner that violates Nuclear Regulatory Commission or equivalent Agreement State license conditions and regulations imposed on the licensee or worker regarding the safe use of the equipment.
9. This warranty shall not apply to products or parts which have been subjected to misuse, improper installation, unauthorized repairs or modifications, neglect or accident conditions. The warranty is void if equipment is not operated and maintained in accordance with instructions provided in SPEC user's manuals. The customer is responsible for returning products to SPEC, freight prepaid, and for preparing the product for shipment in accordance with applicable transport laws and regulations.

2.0 DESCRIPTION

2.1 SPEC-150 Exposure Device

The device consists of a depleted uranium shield inside a welded titanium housing measuring approximately 14.1 cm (5-9/16 inches) high, 13.6 cm (5-3/8 inches) wide, and 36.8 cm (14-1/2 inches) long. The DU shield includes a curved S-tube that the source travels through. The securing and locking mechanisms are installed at one end of the device and an outlet port (outlet nipple) is installed at the other end. The device weighs a maximum of 53.5 pounds.

2.1.1 Exposure Device Key

The device key is attached to the control assembly by a short stainless steel chain to prevent loss of the key. When the controls are not in use, the key is installed in the open end of the adaptor to serve as a dust cap to protect against ingress of foreign material into the control assembly. As an option, the key may be removed from the control assembly and replaced with a conventional dust cover.

2.1.2 Device and Component Drawings

Drawings of the SPEC-150 Exposure Device, ASM/Lock Module, Safety Plug, Outlet Panel Assembly, Lock Cap, Control Assembly Adaptor, and G-60 Source Assembly are in the appendix to this manual.

2.1.3 Labeling and Marking

1. The exposure device nameplate is marked with SPEC's name, address, device model, serial number, curie capacity and radionuclide, mass of depleted uranium shielding, and device weight.
2. One caution label stating "Caution - Radioactive Material - Do Not Handle - Notify Civil Authorities if Found."
3. The warning labels state:

WARNING - DANGER

Radiation may cause radiation burns, sickness, cancer, genetic defects, and death. This device may be used only by authorized and monitored individuals who have been formally trained in the use of this device, the proper use of survey instruments, and radiation safety. This device must be used in strict compliance with operating and emergency procedures and applicable regulations. It must be used with a calibrated survey instrument at all times. Trainees, helpers and assistants must work under the direct surveillance of a radiographer.

4. The source identification tag lists the isotope, source model, serial number, activity, and date of manufacture. A tag is provided with each source.
5. Licensees must apply their company name, address and telephone number to the exterior of the exposure device to meet 10 CFR Part 34.20 (b) (v). The labeling may be painted directly on the device or a printed label may be attached by adhesives. Drilling, riveting or welding is prohibited.

2.1.4 Materials of Construction

The principal materials used in the SPEC-150 are a depleted uranium shield and a titanium housing and structure. Stainless steel fittings, bronze bushings, epoxy potting compound, polyurethane foam fill and rubber are non-structural materials of construction.

2.2 Control Assembly

The control assembly, commonly called a crank-out, is a manually operated mechanical apparatus used to move the source assembly from the exposure device to the exposed working position at the end of the guide tube and back into the exposure device from a safe distance.

It consists of a pistol grip assembly, two conduits (sheaths) typically 25 to 50 feet long, a flexible metal drive cable with a connector to attach to the source assembly, a drive cable stop, and an adaptor to attach the control assembly to the exposure device. The pistol grip consists of an aluminum housing, drive gear, wear ring, two bearings, and crank handle.

2.2.1 Control Assembly Lengths and Materials

Control assemblies are available in a variety of conduit types and lengths. Custom designed, or extra length control assemblies may require government authorization. Consult with SPEC or your licensing authority to verify.

	<u>Max. Length</u>
Controls with Yellow conduit	35 ft.
Controls with Red conduit	40 ft.
Controls with Blue conduit	50 ft.
Controls with two types of conduit	See Note 1

Note 1: The length of a control assembly made with two types of conduits (i.e., Yellow and Silver) is limited by the maximum length specified for the type of conduit installed on the drive (upper) side of the control assembly pistol grip.

2.2.2 Control Assembly Operation

The control assembly is typically operated by hand, yet may be operated mechanically. The pistol grip cover plate is permanently marked with the words "expose" and "retract" and with arrows to indicate the directions of cranking motion to expose or retract the source assembly. Clockwise cranking is used to crank out and counterclockwise cranking is used to retract.

The typical amount of torque required to operate the system freely with a 25 foot control assembly is approximately 1-1/4 foot pounds. The maximum amount of torque should not exceed approximately 2 foot pounds when operated by hand. If an automatic mechanical apparatus is used to operate the control assembly, the maximum amount of torque allowed to be applied to the drive gear is 4 foot pounds.

2.2.3 Control Assembly Adaptor

The control assembly adaptor is used to attach the control assembly to the exposure device. After the device is unlocked, the spring-loaded operating lever on the adaptor is used to unlock the source assembly. The adaptor may be used on any control assembly authorized for use with the SPEC-150.

2.2.4 Control Assembly Drive Cable and Connector

The drive cable is a flexible wire steel cable with a connector at one end (to attach to the source assembly) and a spiral "stop" spring at the other end (to prohibit accidental loss). The cable meshes with the gear inside the pistol grip and is moved as the control handle is rotated.

The drive cable connector is the SPEC Fail-Safe connector and is the same connector used for SPEC 2-T model G-1F and G-3F sources and other source models using the Fail-Safe connector.

2.3 Guide Tubes

Guide tubes are hollow flexible or rigid tubes with an end piece (exposure head) attached to the working (exposure) end. SPEC "Yellow" guide tube material designates yellow-colored, PVC covered, 3/8 inch inside diameter, flexible Type 302 stainless steel inner core material. SPEC "Rigid" material designates Type 304 or 316 stainless steel, 3/8 and 1/2 inch inside diameter, seamless rigid tubing. This material is used for "J" tubes and other specialized applications. The maximum standard length, with extension(s), is 21 feet. Longer and custom designed guide tubes might require government authorization. Consult with SPEC or your licensing authority to verify requirements.

3.0 GENERAL CONDITIONS OF USE

3.1 Intended Use

The SPEC-150 exposure device is intended for industrial gamma radiography operations at temporary job site and permanent facilities in all industries and locations. Typical industries and locations are associated with oilfield, petrochemical, marine, construction, manufacturing, and aerospace activities. It is expected that the equipment will be used at offshore structures, metal fabrication yards, foundries, chemical plants, refineries, shipyards, building sites, laboratories, and maintenance facilities.

3.2 Environmental Conditions of Use

The SPEC-150 exposure device is designed to perform industrial radiography at field sites and permanent facilities with a broad range of environmental conditions. It will operate properly within a temperature range of -40 degrees F to +180 degrees F and in all levels of relative humidity and moisture. The device is resistant to corrosion from typical industrial and environmental atmospheres. For use underwater, the device must be installed in a protective enclosure or other precautions must be taken to prohibit damage to internal components due to slow corrosion. Licensees should consult with the applicable government licensing agency to determine if specific authority is required to use the SPEC-150 exposure device underwater.

3.3 Installation

There are no installation requirements. The device is not normally installed (attached) in a permanent manner. If the device must be installed, the user should develop the means to secure the device as needed for safety and security. The eight tie-down holes at the top and bottom corners of the device provide a means for the user to attach mechanical safety, security and lifting attachments.

3.4 Basic Operation

In typical use, a manual remote control assembly and guide tube are attached to the device during set up of the SPEC-150 System. The exposure device is unlocked with a key, then the source assembly is unlocked with the control adaptor operating lever. Then, before each radiographic exposure, the source assembly is unsecured from the automatic securing mechanism (ASM) by depressing the release plunger on the top of the device. The control assembly is used to move the source assembly out of the shielded position to the final working position at the end of the guide tube. When the source assembly is retracted back into the fully shielded position inside the device, it is automatically secured by the ASM. Finally, a safety check must be performed with a survey instrument after each exposure.

3.5 Occasions for Persons to be Near the Device

Only specifically trained, authorized, and monitored individuals are allowed to be near the device when it is in use. Unauthorized individuals must be restricted by the user from close proximity to the device to meet applicable radiation dose limit regulations. It is expected that unmonitored persons, such as shipping, transport and emergency response personnel will be near the device only after it has been properly prepared for transport.

3.6 Special Equipment Use

If the SPEC-150 must be used in working positions that are difficult or dangerous for the worker to reach (for example, when suspended off the ground or on a trolley inside a pipe), it is recommended that the licensee apply for authorization to use a remote unsecuring mechanism. Contact SPEC for assistance.

4.0 MECHANICAL SAFETY FEATURES OF THE DEVICE

4.1 Exposure Device Lock

The device lock is located at the bottom of the lock end plate. It is operated by a durable, circular, stainless steel key. The safety features of the device lock are described below.

1. The key cannot be intentionally removed nor inadvertently fall out when the device is unlocked.
2. The key serves as a dust cover for the device lock and limits ingress of foreign material when the device is in use. The key may also be used as a dust cover for the control assembly when it is not in use.
3. The key must be removed to disconnect the control adaptor from the exposure device. Therefore, the key cannot be inadvertently left in the device when breaking down the system.
4. The lock cannot be unlocked with a readily available substitute for the key.
5. The lock cannot be removed from the ASM/Lock Module.

4.2 Source Assembly Lock

The source assembly lock is located at the center of the lock end plate. It prohibits movement of the source assembly in both directions when engaged. It is manually operated by use of the operating lever on the control assembly adaptor. The lever must be rotated toward the "Unlock" position to disengage the source assembly lock. The numerous safety features of the source assembly lock are described below.

1. The source assembly lock cannot be operated with a readily available substitute for the control assembly adaptor operating lever.
2. The control assembly adaptor must be properly attached to the exposure device to operate the source assembly lock.
3. The source assembly lock cannot be disengaged unless the exposure device is unlocked.
4. When the source assembly lock is engaged, the release plunger cannot be engaged (latched down). Therefore, the source assembly cannot be inadvertently unsecured.
5. The source assembly lock can be conveniently engaged to provide an added measure of security during temporary interruptions in radiography operation.
6. The exposure device cannot be locked when the source assembly lock is disengaged.
7. In accordance with ANSI N432 Section 5.1.2.4, the source assembly lock **ABSOLUTELY, POSITIVELY** cannot be engaged unless the source assembly has been retracted to the fully secured position. The user cannot inadvertently lock the source out.
8. The control adaptor cannot be attached to the device if the drive cable connector has not been attached to the source assembly connector.

4.3 Automatic Securing Mechanism (ASM)

The ASM automatically secures the source assembly when it is fully retracted into the device. It prevents movement of the source assembly toward the outlet end. The source assembly must be unsecured from the ASM by depressing the release plunger located at the top of the device before each radiographic exposure. The release plunger latches in the engaged (down) position when pushed down. When the source assembly is cranked forward, the release plunger automatically unlatches and pops back up to its original position. The safety features of the ASM are described below.

1. THE ASM CANNOT TRIP PREMATURELY AND LOCK THE SOURCE ASSEMBLY OUT! It has no moving parts and is very reliable.

2. THE ASM CANNOT BE MECHANICALLY DEFEATED! Vice grips, clamps, pins and duct tape cannot be used to defeat the ASM. If the release plunger is held down, the source assembly cannot be cranked out of the device.
3. The ASM release plunger is NOT a source assembly position indicator. It springs up as soon as the source assembly is cranked forward, not after it is cranked back into the device. Therefore, it cannot be misconstrued as being a source position indicator, secured position indicator, nor any other type of potentially hazardous visual indicator that is subject to FALSE-POSITIVE indications of safety. It cannot "invite", nor influence, the worker to refrain from using the survey instrument.
4. No "extra" cranking force is needed to secure the source assembly when it is cranked into the device. The securing mechanism uses no springs and is completely automatic.
5. The SPEC-150 meets the ISO 3999 standard by providing a mechanical means for the user to verify that the source assembly is in the secured position. This is accomplished by gently attempting to crank the source assembly forward after it has been retracted into the device.
6. The release plunger is very durable and may be operated by foot.
7. The ASM also prohibits the source assembly from being pulled out of the lock end of the device even when both locks are open.

4.4 ASM/Lock Module

The ASM/Lock Module contains the exposure device lock, source assembly lock, and the automatic securing mechanism (ASM). It is easily replaced by authorized users without special training. The safety features are described below.

1. The module is a contained unit that requires NO disassembly for cleaning, maintenance, or lubrication by the user. Although the SPEC-150 Exposure Device is designed to operate reliably without lubrication, users may use lubrication that is suitable for the operating environment. If lubrication is used, users should consider the need to remove and / or replace the lubrication if significant changes in environment are encountered.
2. Special tools are required to remove the module. This protects against unauthorized removal.
3. The lock module cannot be removed from the device until the source assembly has been removed. This prevents the source assembly from being temporarily unlocked and subject to mishap when the module is in the process of being replaced.
4. The lock module is contained inside the device for protection from accidental impact.

4.5 No Visual "Source Position" Indicator

The SPEC-150 system is free of any mechanical device that could be misconstrued as being a "source position" indicator of any type. Typical source position indicators are potential safety hazards. This position is based on (a) the current state of technology, (b) current industry and government expert opinion regarding indicators, and (c) current scientific safety research. The potential hazards associated with mechanical source position indicators have been debated for many years in the radiography industry. Each point is explained in more detail below to assist licensees in providing safety training to workers.

1. The current state of technology does not offer an indicator design that provides a greater degree of safety to the worker than the survey instrument. Existing mechanical indicators are not true "redundant" safety devices since they do not provide an equal level of reliability as the survey instrument. The superior reliability of the survey instrument is based on two facts. First, it responds to radiation, not the mechanical presence of a component of the source assembly. Second, the operability of a survey instrument can be easily, conveniently, and reliably determined by the worker at a glance each time the instrument is used. No additional separate inspection is necessary to verify that it is responding to radiation. Mechanical indicators require a separate, independent inspection of some sort to verify proper operation. Malfunctions are not readily apparent to the worker.
2. Industry and government opposition to visual indicators is reflected in various public records. The public comments submitted to the NRC in response to a Proposed Rule in 1989 to require an indicator were overwhelmingly in opposition to the indicator. The proposed rule was rejected by the NRC based on safety concerns. The Atomic Energy Control Board of Canada also reviewed and rejected a proposed rule to require a visual indicator on radiography exposure devices. This opinion is also reflected in the current revisions of ANSI N43.9-1991 and ISO 3999 standards.
3. Mechanical indicators are subject to FALSE-POSITIVE indications of safety. Malfunctions due to wear, dirt or defects often cause them to trip prematurely with the source out. They can also provide false-positive indications even when they are functioning properly, such as when a source capsule is detached from the source assembly. Documented incidents have occurred in which indicators gave false-positive indications of safety that resulted in human fatalities. The false-positive indications influenced the workers to refrain from using their survey instruments, which could have prevented the fatalities.
4. Finally, mechanical source position indicators conflict with basic safety theory described in the scientific safety research. Research shows that it is counterproductive to provide "safety" features that reduce the worker's perception of risk to a level that produces an offsetting reduction in safety behavior.

4.6 Source Assembly Misconnect Protection

The control assembly adaptor cannot be attached to the exposure device if the drive cable connector is not attached to the source assembly connector. This prohibits operation of the device when a "misconnect" between the drive cable and source assembly exists.

WARNING

An excessively worn drive cable connector can allow the control assembly adaptor to attach to the device when a misconnect between the drive cable and source assembly exists. Users must inspect the drive cable connector on a daily basis to check for wear. If the ball end of the drive cable connector becomes worn to the extent that it is visually blunt, it must be replaced.

4.7 Lock Cap

The lock cap is a titanium assembly that attaches to the control assembly attachment boss located at the top center of the lock end plate. It is used to protect against ingress of foreign material when the device is not in use and to protect the source assembly connector from accidental impact.

4.8 Safety Plug

The safety plug is a stainless steel assembly that attaches to the outlet nipple. It is used to protect against ingress of foreign material in the outlet nipple when the device is not in use and to protect the outlet nipple against accidental impact. It must be installed during transport as a redundant means to prevent loss of the source assembly in an accident.

4.9 Error-Free Design

The SPEC-150 design uses a lock step set-up and break-down process that prohibits workers from doing steps that are inadvertently out of the proper sequence or from omitting steps.

4.10 Lubrication-Free Design

Although the SPEC-150 Exposure Device is designed to operate reliably without lubrication, users may use lubrication that is suitable for the operating environment. If lubrication is used, users should consider the need to perform maintenance to remove and/or replace the lubrication if significant changes in environment are encountered.

4.11 Carrying Handle & Tie-Down Holes

The device has eight convenient tie-down holes located at the top and bottom corners of the housing. The holes provide a sturdy means to attach lifting harnesses, security and safety harnesses, pipeline trolleys, and permanent installation mounts. The carrying handle may also be used to attach lifting harnesses.

4.12 Protection from Unauthorized Access

The SPEC-150 exposure device is designed to prevent access to the radioactive source by unauthorized personnel, such as the public. The design features that contribute to the prevention of unauthorized access are noted below.

1. The SPEC-150 is equipped with a keyed device lock. It cannot be unlocked by a readily available substitute for the key.
2. The device lock, source lock and securing mechanism cannot be removed from the ASM/Lock Module.
3. The ASM/Lock Module and Outlet Panel Assembly are the only components critical to safety that are able to be removed from the device by any means. The tools required to remove them are specially designed and are not commonly available. It is recommended that access to the special tools be controlled by the Radiation Safety Officer or authorized designee.
4. The source assembly lock cannot be unlocked without the use of the control assembly operating lever, which can be used only when the control adaptor is attached to the device. There is no readily available substitute for the operating lever.
5. The ASM/Lock Module cannot be removed from the device with the source assembly installed. The source assembly cannot be removed without a key and control assembly.
6. Caution and warning labels are permanently attached to the device which clearly explain the hazards of radiation and provide instructions to notify civil authorities if found.

5.0 RADIATION SAFETY FEATURES

5.1 External Radiation Levels

A 37 pound depleted uranium casting surrounds a titanium or zircalloy "S-tube" which holds and guides the source assembly. The highest external radiation levels of the device are approximately 1.5 mSv (150 millirem) per hour at the surface and 0.016 mSv (1.6 millirem) per hour at one meter from the surface.

5.2 Protection from Scattered Radiation

The safety plug shields the scattered radiation at the outlet nipple and should be installed at all times when a guide tube is not attached and when the device is stored or transported. The lock cap shields the scattered radiation at the lock end of the device and also must be attached when the device is stored or transported.

5.3 Protection from DU Contamination

The depleted uranium shield is completely enclosed in a titanium housing. The S-tube protects the source assembly from contamination inside the shield.

6.0 SPEC-150 SYSTEM OPERATING PROCEDURES

6.1 Safety Precautions

6.1.1 Survey Instrument

Safe operation begins with inspecting the survey instrument to verify that it is operating properly. The inspection must be done in accordance with safety regulations and employer operating procedures before the SPEC-150 is handled or prepared for transport. It is recommended that each worker inspect the exact survey instrument to be used by him/her during that work shift.

The survey instrument **MUST** be used after each exposure regardless of other safety equipment being used such as a control assembly odometer, radiation beeper (chirper), or alarming ratemeter. All of the above items are less reliable than a survey instrument and are subject to FALSE-POSITIVE indications of safety.

Workers should note the radiation levels during the first exposure of each new set up. The survey instrument's response to radiation should be approximately the same for each subsequent exposure. Observing the instrument's response during an exposure is a very reliable indication of the operability of the instrument. Unusual readings should be treated as a potentially hazardous condition and should be resolved before proceeding. It could be caused by a defective survey instrument, exposure device, or source assembly.

It is highly recommended that the survey instrument's response to radiation be measured at the beginning of each shift before removing the exposure device from storage (if possible). This is a quick, simple procedure called a "reference reading" and it provides valuable safety information. To obtain a reference reading, the survey instrument should be placed at the surface of one side of the exposure device. The reference reading should be recorded.

Periodically during the work shift, and whenever damage to the survey instrument is suspected, a radiation reading should be made at the same spot and compared with the reference reading to determine if the survey instrument's response to radiation has changed. A **SIGNIFICANT** change in radiation reading should be treated as a potentially hazardous condition and should be resolved before proceeding. It could be caused by a defective survey instrument, exposure device or source assembly.

The same spot on the surface of the device should be surveyed to obtain the reference reading every day. This is so the reference reading will remain approximately the same from day to day if the same source and survey instrument are used. The decay rate of Iridium-192 is approximately 1% per day.

6.1.2 Personnel Training and Supervision

All workers must be specifically trained, qualified and authorized to use the SPEC-150 by the licensee and, as applicable, by the government licensing agency. Helpers, trainees and assistants must operate the SPEC-150 only under the direct visual surveillance of a qualified radiographer.

6.1.3 Personnel Monitoring

Personnel radiation monitoring devices must be used at all times in accordance with regulations and employer Operating and Emergency Procedures.

6.1.4 Protection from Direct Radiation

Protection from direct radiation is provided by the DU shield when the source is properly secured in the device. When the source is moved out of the device to perform radiography, the radiation beam is fully unshielded in all directions when moving through the guide tube to the working position. To limit human exposure to radiation, collimators should be used when possible to reduce direct radiation in unwanted areas when the source is exposed. Collimators are available in a variety of sizes, shapes and shielding capabilities to meet safety requirements.

6.1.5 Protection from Scattered Radiation

The radiation level at the outlet nipple opening of the SPEC-150 , with the safety plug removed, is approximately one (1) rem. This is very low for a "crank-out" type of radiography device. Nevertheless, individuals should refrain from placing fingers in the outlet nipple opening when the safety plug is removed. No special precautions are required to protect the fingers when installing a guide tube or performing a wipe test other than to complete the procedure quickly, which is normally a few seconds. The dose to the fingers will be minimal and well within allowable dose limits.

CAUTION

TO PREVENT UNNECESSARY RADIATION DOSE TO THE EYES, DO NOT PUT EYES WITHIN TWO (2) FEET WHILE IN ALIGNMENT WITH THE S-TUBE OPENINGS WHEN AN ACTIVE SOURCE IS INSIDE THE DEVICE.

6.2 SPEC-150 Radiography System Set-Up Procedures

1. Inspect the survey instrument to verify proper operation.
2. Survey the exposure device to verify the source is properly shielded. It is recommended that the worker make and record a reference radiation reading as described in Section 6.1.1.
3. Remove the spring loaded lock cap by rotating the cap counter-clockwise 45 degrees. It may be stored by attaching to the boss fitting located on the outlet end flange.

4. Remove the dust cover from the control assembly and crank out a few inches of drive cable.
5. Attach the drive cable connector to the source assembly connector by retracting the piston in the source assembly connector and inserting the drive cable connector at an approximate 90 degree angle. Swivel the drive cable in alignment.
6. Crank the controls counter-clockwise to retract the drive cable until the control adaptor is drawn flush with the device.
7. Attach the control adaptor to the control attachment boss at a 45 degree angle (with the bottom of the control adaptor pointing toward the 4 o'clock position). Rotate the control adaptor clockwise until it is vertical.
8. Disconnect the safety plug from the outlet end of the device and store it in the carrying handle.
9. Attach the guide tube to the outlet nipple and verify that it is securely fastened by tugging lightly after the connection is made.
10. Extend the control assembly and guide tube as straight as possible and avoid sharp bends. Do not pull the exposure device using the controls. Avoid dragging the conduits over objects that might catch, cut or melt them or damage the fittings.

CAUTION

The minimum allowable bend radius for the guide tube is three (3) inches. Sharper bends may cause the source assembly to become stuck.

NOTICE

A RESTRICTED AREA MUST BE ESTABLISHED AND POSTED IN ACCORDANCE WITH EMPLOYER OPERATING PROCEDURES AND SAFETY REGULATIONS BEFORE EXPOSING THE SOURCE.

6.3 SPEC-150 Radiography System Operation Procedures

1. To unlock the device, insert the key into the device lock. Push the key in and rotate clockwise approximately 45 degrees until the rotation stops. The device key will point toward the "UNLOCK" position.
2. To unlock the source assembly, push the control adaptor operating lever into the device and rotate counter-clockwise approximately 45 degrees. The operating lever will point toward the "UNLOCK" position.

3. To unsecure the source assembly, push the release plunger until it latches in the unsecured (down) position. The source assembly is now able to be cranked out of the device.
4. Rotate the crank handle on the control assembly pistol clockwise to expose the source. The release plunger will immediately spring up when the source assembly is cranked forward.

NOTICE

THE RELEASE PLUNGER IS NOT A SOURCE POSITION INDICATOR. IT MUST NOT BE USED AS A SAFETY INDICATOR OF ANY KIND.

5. When the desired exposure time has elapsed, rotate the crank handle counter-clockwise to retract the source assembly.

WARNING WARNING WARNING

A calibrated and properly operating survey instrument must be used at all times when handling or using the SPEC-150 Exposure Device. Failure to comply with this requirement is a violation of safety regulations and may result in harmful radiation overexposure, injury and death in the event of human error, equipment malfunction, or accident.

WARNING

Do not attempt to bypass the ASM by intentionally refraining from cranking the source assembly into the fully shielded position. The radiation level at the outlet end of the device could be extremely hazardous and the source assembly could become fully unshielded while repositioning the device. Any attempt to bypass the ASM is willful violation of safety regulations that could cause harmful radiation overexposure, injury and death.

NOTICE

Be alert to any significant increase in resistance to cranking the controls while exposing or retracting the source assembly. Unusual resistance indicates damaged or dirty equipment and could cause a malfunction.

6. Test to verify that the source assembly is secured by relaxing backward cranking force and then applying slight forward cranking motion. The source assembly should be unable to move forward.

CAUTION

If the source can be cranked forward, attempt to secure it by cranking it back and test it again. If it cannot be secured, the equipment has malfunctioned. Apply light counter-clockwise force to the control assembly crank handle, survey the device to verify that no radiation hazard exists, lock the source and device and immediately remove the device from use.

7. Approach the exposure device with a survey instrument in hand and perform a survey in accordance with safety regulations and the employer's operating procedures.

6.4 SPEC-150 Radiography System Break-Down Procedures

1. Survey the exposure device according to safety regulations and the employer's operating procedures to verify that the source is properly shielded.
2. To lock the source assembly, rotate the control adaptor operating lever clockwise approximately 45 degrees toward the "LOCK" position. The lever should point down vertically. The source assembly can no longer be unsecured by pushing down the release plunger.

WARNING WARNING WARNING

A calibrated and properly operating survey instrument must be used at all times when handling or using the SPEC-150 Exposure Device. Failure to comply with this requirement is a violation of safety regulations and may result in harmful radiation overexposure, injury and death in the event of human error, equipment malfunction, or accident.

CAUTION

The operating lever must be completely vertical to lock the source assembly. If it cannot be placed in the vertical position, extend the control assembly completely, retract the source assembly into the fully secured position again, survey the device, and attempt to lock the source assembly again. If the source assembly cannot be locked, the device has malfunctioned and must be taken out of service immediately. Refer to the employer's Operating and Emergency Procedures. **DO NOT** attempt to disassemble or repair the equipment.

3. Remove the guide tube from the outlet nipple.
4. Attach the safety plug to the outlet nipple and verify that it is securely fastened by tugging lightly after it is installed.
5. To lock the device, rotate the key counter-clockwise approximately 45 degrees toward the "Lock" position until rotation stops. The finger grooves on the key should be vertical and should spring outward slightly.

CAUTION

The finger grooves on the key must be vertical to lock the device. If it cannot be rotated completely, apply additional force by hand. If it still cannot be rotated completely, the device has malfunctioned and must be taken out of service immediately. Refer to the employer's Operating and Emergency Procedures. DO NOT attempt to disassemble or repair the equipment.

6. Remove the control adaptor by rotating it counter-clockwise approximately 45 degrees (pointing toward the 4 o'clock position), and pull the adaptor off while cranking the drive cable forward a few inches.
7. Swivel the drive cable connector 90 degrees, push forward lightly to compress the spring in the source assembly connector, and pull the drive cable connector out of the side hole of the source assembly connector.
8. Retract the drive cable completely and install the key (or separate dust cover) into the control adaptor.
9. Install the lock cap on the control attachment boss at a 45 degree angle, rotate it clockwise until rotation stops. The lock cap should be positioned vertically.
10. Prepare the device for transportation and/or storage in accordance with applicable regulations, the employer's operating procedures, and the instructions in Section 9.

6.5 Emergency Response Procedures

An emergency exists when the radioactive source cannot be returned to the fully shielded position within the SPEC-150 exposure device. Any equipment malfunction or accident (including transport accident) that could cause the source to be unshielded or unsafe should immediately be treated as an emergency until the exact status is determined to be safe.

6.5.1 Equipment Malfunctions and Accidents

The procedures in the employer's Operating and Emergency Procedures Manual must be strictly followed in an emergency. The emergency procedures recommended by the U.S. Nuclear Regulatory Commission consist of the following:

1. Quickly move away from the exposed source
2. STAY CALM, DO NOT PANIC. STOP AND THINK!
3. Establish or extend the restricted area.
4. Send for help and maintain surveillance.

DO NOT ATTEMPT TO RETRIEVE THE SOURCE OR ENGAGE IN EMERGENCY REPAIRS IF YOU HAVE NOT BEEN TRAINED AND AUTHORIZED TO DO SO. Be prepared to provide a detailed description of the incident to emergency response personnel. It is important for this information to be as accurate as possible for the safety of the emergency response personnel. SPEC is available to provide emergency assistance on a 24-hour basis. **Phone 504-464-9471.**

6.5.2 Fire

In the event of a fire, attempt to crank the source in and move the SPEC-150 to a safe area ONLY if this can be done without risk of personal injury. The SPEC-150 is designed to maintain shielding integrity when subjected to a fire at a temperature of 1475 degrees Fahrenheit for 30 minutes.

Immediately inform emergency response personnel about the potential radiation hazard. If the source is unshielded, warn fire personnel to remain outside of the restricted area and fight the fire from the greatest distance possible. Advise emergency personnel to refrain from entering the high radiation area unless required to remove injured individuals. Be prepared to monitor radiation levels if needed. Follow the above emergency procedures as much as possible.

WARNING WARNING WARNING

A calibrated and properly operating survey instrument must be used at all times when handling or using the SPEC-150 Exposure Device. Failure to comply with this requirement is a violation of safety regulations and may result in harmful radiation overexposure, injury and death in the event of human error, equipment malfunction, or accident.

6.5.3 Lost or Stolen Source

IMMEDIATELY notify the Radiation Safety Officer or other personnel as described in the employer's Operating and Emergency Procedures Manual if the source or exposure device is suspected to be lost or stolen.

7.0 SPEC-150 SAFETY INSPECTION PROCEDURES

Safety inspections by the user are required to determine if the radiography equipment is operating properly and is safe to use. The SPEC-150 system is manufactured with the highest degree of quality and durability. However, all equipment is subject to malfunctions due to extended use, abuse, neglect, and damage from accidents. Safety inspections must be performed by trained, qualified and authorized individuals.

7.1 Daily Safety Inspection Procedures

It is recommended that a checklist be used to conduct the inspection and record the results. Any equipment that fails the Daily Safety Inspection must be immediately taken out of service, reported to the Radiation Safety Officer, and replaced or repaired before use.

7.1.1 Survey Instrument

Each survey instrument should be carefully inspected in accordance with the manufacturer's instructions, safety regulations and the employer's Operating Procedures. The inspection must include a check of the following as a minimum.

1. Battery condition.
2. Calibration expiration date.
3. Response to radiation.

7.1.2 SPEC-150 Exposure Device

1. Survey the device in accordance with employer's Operating Procedures using a calibrated and properly operating survey instrument with the lock cap and safety plug installed.
2. Pull lightly on the safety plug, without retracting the spring-loaded, knurled ring to determine if it is firmly attached to the outlet nipple.

CAUTION

TO PREVENT UNNECESSARY RADIATION DOSE TO THE EYES, DO NOT PUT EYES WITHIN TWO (2) FEET WHILE IN ALIGNMENT WITH THE S-TUBE OPENINGS. DO NOT PLACE FINGERS ON THE OUTLET NIPPLE OPENING.

3. Remove the safety plug and visually inspect the outlet nipple for excessive wear, dents, cracks, or other obvious damage. Check to determine if the outlet nipple is loose.
4. Install the safety plug in the outlet nipple and in the storage nipple in the carrying handle to verify proper operation.
5. Pull on the lock cap to determine if it is firmly attached to the device.
6. Rotate the lock cap to determine if it rotates freely and provides sufficient spring force.
7. Remove the lock cap and install it on the storage boss on the outlet end flange of the exposure device to verify proper operation.

8. Visually inspect the source assembly connector in accordance with Section 7.1.3 (below).
9. Visually inspect the control adaptor attachment boss to check for cracks, dents, wear or other obvious damage.
10. Visually inspect the carrying handle and handle brackets for cracks and other obvious damage.
11. Visually inspect the eight tie-down holes at the top and bottom corners of the device to check for cracks.
12. Visually inspect to verify that the nameplate, source tag, and all caution and warning labels are completely legible.
13. Visually check the exposed fasteners and welds.

7.1.3 Source Assembly Connector

1. Visually inspect to ensure that the source assembly connector is not cracked, worn, or otherwise damaged.
2. Visually inspect the source assembly connector to check for foreign matter such as dirt, grease and grit. Use a brush or cloth to apply any mild cleaning solvent as needed for the type of foreign material to be removed. Excess residue should be wiped off. Aerosol spray solvents should be used with caution to avoid spraying into the device.
3. Push the connector piston to verify that it is free of foreign material and corrosion and also to check that normal spring force exists.
4. Attach the drive cable connector to the source assembly connector. It should attach securely and rotate freely.
5. Swivel the drive cable connector from one side to the other and visually estimate the arc of swivel. The connector should swivel approximately 90 degrees in one direction and approximately 14-28 degrees in all other directions.

CAUTION

THE INSPECTOR SHOULD WASH HANDS THOROUGHLY AFTER HANDLING THE CONNECTOR TO REMOVE ANY SOLVENTS AND POTENTIAL CONTAMINATION.

7.1.4 Control Assembly

1. Remove the dust cover and slowly crank a few feet of drive cable out and back in (onto a clean surface) to determine if there is unusual resistance to cranking. Unusual resistance indicates damaged or dirty equipment.
2. Visually inspect the control conduits (sheaths) for dents, cuts or other damage.
3. Manually check the conduits for loose, broken or damaged fittings.

7.1.5 Pistol Grip Daily Inspection

1. Visually check the control pistol housing for loose components and obvious defects, such as missing screws, bent or broken handle and crank arm and worn bearings.
2. Visually inspect to verify that the "Expose" and "Retract" markings are clearly legible.
3. To check the gear for excessive wear, leave the dust cover attached to the control adaptor and attempt to crank forward with moderate force.

NOTE: If the drive cable "skips" over the gear, the control assembly must be removed from service.

7.1.6 Drive Cable

1. Bend the last 6" of drive cable in a "U" shaped curve approximately 3" wide. When the drive cable is released, the end of the drive cable should spring back to its original straight shape.

NOTE: Failure to spring back indicates that corrosion has reduced the flexibility of the drive cable which could cause a malfunction. The drive cable must be replaced.

2. Visually inspect the end of the drive cable for loose, bent or broken wire strands close to the connector.

7.1.7 Drive Cable Connector

The drive cable connector is VERY critical to safety. Extra care should be taken when inspecting it.

1. Manually attempt to twist the drive cable connector to verify that it is firmly attached to the drive cable.
2. Closely inspect the connector for excessive wear to the ball and to determine if the neck is bent or cracked. If the connector neck is bent more than 10 degrees it

should be replaced. Do not straighten a bent connector neck. Bending can crack and weaken the neck.

3. Users must inspect the drive cable connector on a daily basis to check for wear. If the ball end of the drive cable connector becomes worn to the extent that it is visually blunt, it must be replaced. As a check, and since the control assembly adaptor is designed so that it cannot be attached to the exposure device if the drive cable connector is not attached to the source assembly connector, at the start of the day an attempt should be made to attach the control adaptor without connecting the drive cable and source assembly. If the control adaptor is attached to the device under this conditions, the system should not be used and the drive cable connector should be replaced.

CAUTION

If the drive cable connector is loose, worn or damaged in any way **DO NOT USE THE DRIVE CABLE**. Remove it from service **IMMEDIATELY!** A defective connector can cause a variety of equipment malfunctions and hazardous conditions.

7.1.8 Control Assembly Adaptor

1. Visually inspect the O-ring for cracks, cuts, breaks and deformities.
2. Manually check the operating lever to determine if it slides and rotates freely and that the spring is strong and undamaged. Check the operating lever tab to ensure that it is square, not rounded or broken off.
3. Using light force, attempt to install the control adaptor on the exposure device with the drive cable and source assembly disconnected. If the adaptor can be installed, it is possible for a missed connection condition to occur. Remove the equipment from service.

7.1.9 Guide Tube Daily Inspection

1. Visually and manually inspect the guide tube for kinks, dents and cuts. Slide the hand along the length of the guide tube to feel for damage.
2. Manually check the guide tube for loose, broken or damaged fittings.
3. Check for internal debris, obstructions and damage by sliding a dummy source assembly through the entire length of the guide tube. Use gravity only, do not push. If a dummy pigtail is not available, a ball or short rod with a diameter measuring between 5/16" and 11/32" should be used.

NOTICE

If internal cleaning is needed, use a wire and cloth with mild solvent to clean. Do not use lubricants. It is NOT recommended to flush with liquids or use compressed air. These methods can cause trace amounts of Ir-192 or depleted uranium contamination to be released. Precautions should be taken to prevent exposure to the hands, and/or ingestion or inhalation.

4. Verify that threaded fittings, such as exposure heads and connection fittings, are firmly attached by manually attempting to tighten them.
5. Attach the guide tube to the outlet nipple. Verify that it is securely installed by attempting to remove it by applying a light pull by hand.
6. Check the collimator to determine if it is fully and securely attached to the end of the exposure head (end piece).

7.2 Quarterly Safety Inspection Procedures

The Quarterly Safety Inspection is a detailed inspection to determine if maintenance or repairs are required. It should be conducted on a quarterly basis and any time there is an indication of a malfunction or damage.

Inspections should be performed by the Radiation Safety Officer or other trained and qualified individual authorized by the licensee to perform the quarterly inspection and conduct source exchanges using the SPEC C-1 source changer. It is recommended that a checklist be used to conduct the inspection and record the results. Any equipment that fails the Quarterly Inspection must be immediately taken out of service, repaired before use, or replaced.

The quarterly inspection must include the steps described in the Daily Safety Inspection Procedures, Section 7.1, the SPEC-150 System Operational Check, Section 7.2.6, and any additional inspection requirements described in the employer's Operation Procedures Manual. Only the additional quarterly inspection steps that are not included in the Daily Safety Inspection Procedures are described here.

7.2.1 Survey Instrument

Perform Daily Inspection, Section 7.1.1.

7.2.2 SPEC-150 Exposure Device

Perform Daily Inspection, Section 7.1.2.

7.2.3 G-60 Source Assembly Connector

Perform Daily Inspection, Section 7.1.3

7.2.4 Control Assembly

Perform Daily Inspection, Sections 7.1.4 through 7.1.8. In addition, use calipers to verify that the diameter of the drive cable connector ball is greater than 0.130 inch. Perform this check for misconnect prevention.

1. Place the opening on the gauge over the "Boss Ears" on the camera where the control adaptor hooks to the camera. The tool should stay on a 30 to 45 degree angle. It should not drop straight up and down (vertically). If it does, the boss is worn on the camera and the camera will have to be sent in to SPEC in order to replace the Boss.

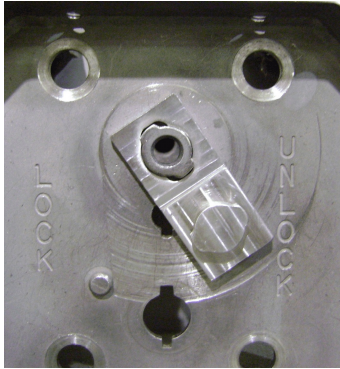

GO



NO-GO

2. Place the "Male" end of the tool into the opening of the Control Adaptor on the controls. You should have the same result, where the tool does not move much if at all. If it does turn in the Control Adaptor, the adaptor will need to be replaced on the controls.



GO

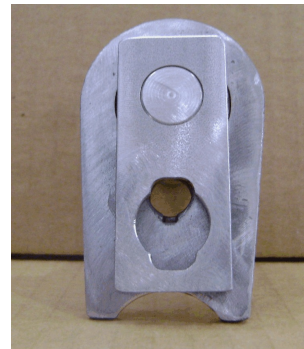

NO-GO

7.2.5 Guide Tube Quarterly Inspection

Perform the Daily Safety Inspection, Section 7.1.9.

7.2.6 SPEC-150 System Operational Check

The following SPEC-150 Exposure Device Operational Check Procedures should be conducted AFTER the quarterly inspection of the individual equipment items have been conducted and all required maintenance or repairs have been completed. A complete operational check must be performed each time the ASM/Lock Module is replaced. The Operational Check is used to determine if all the mechanical and safety features of the system are operating properly.

WARNING

Transfer the active source to a C-1 Source Changer and attach a dummy source assembly before beginning these steps.

Conduct the Operational Check in the EXACT sequence of steps described below. Start with the system completely broken down and locked with safety plug and lock cap installed.

THE FOLLOWING STEPS MUST BE PERFORMED EACH TIME THE ASM/LOCK MODULE IS REPLACED. (SEE SECTION 8.5 FOR ADDITIONAL INFORMATION.)

1. Attempt to unsecure the dummy source assembly by depressing the release plunger down completely. The release plunger should spring back up when released.
2. Remove the lock cap.
3. Attempt to attach the control adaptor to the device WITHOUT connecting the drive cable to the dummy source assembly. The control adaptor MUST NOT be able to attach to the device.
4. Connect the drive cable connector to the dummy source assembly connector and attach the control adaptor to the device.
5. Install the device key, push in and rotate clockwise approximately 45 degrees to unlock the device. Attempt to unsecure the dummy source assembly by depressing the release plunger down completely. The release plunger should spring back up when released.
6. Remove the safety plug and install on the carrying handle. Attach a short guide tube.
7. Push the operating lever into the device and rotate counter-clockwise approximately 45 degrees to unlock the source assembly.
8. Attempt to rotate the device key counter-clockwise to lock the device. The key should not rotate.
9. Depress the release plunger down completely. It should remain "latched" down when released.

10. Extend the control assembly fully and crank the dummy source assembly out of the device. The release plunger should spring up when the dummy source assembly begins to move out of the secured position.
11. Crank the dummy source assembly to the end of the guide tube. There should be no unusual resistance or additional force required to crank the controls.
12. Crank the dummy source assembly fully back into the device. The dummy source assembly should automatically secure without requiring unusual additional cranking force.
13. Verify that the dummy source assembly is secured by attempting to crank forward with light force. It should not move forward.
14. Crank the drive cable back in completely (without the dummy source assembly attached).
15. Attempt to rotate the operating lever clockwise toward the word "Lock." The lever should not be able to rotate completely into the locked position. This verifies that the source assembly lock cannot be locked when the dummy source assembly is missing.
16. Crank the drive cable forward one full revolution.
17. Attempt to rotate the operating lever clockwise again. The lever should not be able to rotate completely into the locked position. This verifies that the source assembly lock cannot be locked over the drive cable when the dummy source assembly is cranked forward.
18. With the drive cable still cranked out, depress the release plunger down completely. It should spring back up when released. This verifies that the release plunger cannot be operated "as normal" when the dummy source assembly is cranked out. It alerts the worker that a potential problem exists.
19. Transfer the active source from the C-1 source changer into the device and break down the system.

8.0 SPEC-150 MAINTENANCE AND REPAIR PROCEDURES

8.1 General

Although daily and quarterly safety inspections are required by regulations, there are no daily or quarterly maintenance requirements for the SPEC-150 exposure device to comply with the warranty conditions for the product. However, a visual check of all external fasteners and welds should be performed as it is required as a condition of the NRC package certificate of conformance. Maintenance and repairs of the SPEC-150 and associated equipment must be done on an as-needed basis in response to safety inspections and malfunction reports from the workers.

Maintenance should be performed by the Radiation Safety Officer or other trained and qualified individual authorized by the licensee. Due to the complexity of some radiography equipment in the United States, the licensee might be required to obtain authorization to perform repairs. It is recommended that licensees consult the NRC or Agreement State licensing agency.

The user should take precautions to protect against exposure to cleaning solvents, if used, and potential radioactive contamination when performing maintenance and repairs.

Source Production & Equipment Co., Inc. offers an Optional Annual Maintenance Program for the SPEC-150. For a set fee, this program provides for a replacement ASM/Lock Module and the annual disassembly and maintenance of the module. More information regarding this program may be obtained by contacting the SPEC sales department at 504-464-9471.

SPEC is available to conduct inspection, maintenance and repairs of the SPEC-150 and all associated equipment. A written report of defects and repairs will be provided to the user.

8.2 Recommended Replacement Components

SPEC recommends that users keep one set of replacement components in stock for each 12 exposure devices in use. The set should consist of an ASM/Lock Module, Outlet Panel Assembly, Control Adaptor, Lock Cap, Safety Plug, Device Key, special tools and one (1) set of O-Ring seals.

8.3 Modifying, Repairing or Tampering with the Device

The SPEC-150 is an industrial radiography exposure device and a Type B (U) radioactive material transport package. NRC and DOT regulations strictly prohibit unauthorized modifications, repairs, or tampering of the device.

8.4 SPEC-150 Exposure Device

The SPEC-150 Exposure Device is designed to limit the ingress of foreign matter such as mud, dirt, grease, sand and grit. The exterior of the device should be cleaned with the safety plug and lock cap installed. Hand cleaning with water, detergents and mild solvents may be used as needed. Do not use high pressure liquid or air cleaner systems to clean the device. Do not disassemble the device to clean.

NOTICE

Although the SPEC-150 Exposure Device is designed to operate reliably without lubrication, users may use lubrication that is suitable for the operating environment. If lubrication is used, users should consider the need to perform maintenance to remove and/or replace the lubrication if significant changes in environment are encountered.

8.5 ASM/Lock Module

Do not replace the tamper resistant bolts or screws with any other type of fastener. The SPEC-150 Exposure Device is licensed as a Type B (U) container and modifications are prohibited.

Notify your Radiation Safety Officer and SPEC immediately if the replacement module does not operate properly.

The ASM/Lock Module Assembly contains the exposure device lock, source assembly lock, and the automatic securing mechanism (ASM). It is removed from the device only with the use of special tools provided by SPEC.

The ASM/Lock Module contains no user serviceable parts. It must be returned annually to SPEC or other licensee authorized to conduct maintenance and repair controlled by an NRC approved QA program.

These instructions must be read completely prior to performing any of the ASM/Lock Module replacement steps. Attempts to alter the step sequence may result in problems during the replacement procedure.

Special Tools (provided by SPEC)

Hand Driver
T-Handle Wrench
Dummy Source Assembly
Dummy Connector
1/8" Punch
Modified Operating Lever

8.5.1 ASM/Lock Module Removal

1. Transfer the source assembly from the exposure device to a C-1 source changer or other storage container. A calibrated and properly operating survey meter must be used during all source transfers in accordance with the company's operating procedures.
2. With the control assembly attached to the exposure device and the drive cable extended through the changer tube (guide tube), connect the drive cable to the dummy connector (not the dummy source assembly) provided with the special tools. (See attached drawing for dummy connector and dummy source assembly illustrations).
3. Crank the dummy connector fully into the exposure device.

4. Lock the exposure device and remove the controls. (Note: The dummy connector will also pull out of the exposure device.)
5. Remove the dummy connector from the drive cable. (After the replacement module is installed, the controls cannot be attached if the dummy connector is still in place.)
6. Using the hand driver, remove the six (6) screws from the ASM / Lock Module lid at the top of the exposure device.
7. Using the special allen wrench, remove the four (4) bolts from the lock end plate. (An alternate tool may be supplied to perform the lock module change out.)
8. Push the exposure device lock inward while lifting the ASM / Lock Module through the top of the exposure device.

8.5.2 ASM / Lock Module Installation

1. Visually inspect the replacement ASM / Lock Module to verify that it is in the locked position, with the key slots in the exposure device lock vertical. (See lock orientation on attached drawing.)
2. Insert the replacement lock module into the exposure device.
3. Insert the device key into the device lock to align the lock module. Note: Even minor misalignment may cause difficulty rotating the operating lever when attempting to unlock the source assembly.
4. Insert the four (4) bolts through the end plate. Hand tighten to protect against cross-threading.
5. Firmly tighten the four (4) bolts using the special allen wrench.
6. Clean and install the six (6) module lid screws into the top of the exposure device using the hand driver.
7. Install the controls (the dummy connector must be removed), unlock the exposure device lock, and unlock the source lock.

Note: If the operating lever or exposure device lock is difficult to rotate, this is an indication that the lock module was not properly aligned with the housing end plate. Loosen all ten (10) fasteners and repeat steps 4-7.

8. Crank the drive cable forward through the exposure device.
9. Attach the dummy source assembly to the drive cable connector and retract it to the fully secured position.

CAUTION

The replacement of the Outlet Panel Assembly may be accomplished without removing the active source from the device. However, it is recommended that the source be removed from the device and stored in a C-1 source changer to reduce the radiation dose to the fingers during the replacement of the assembly. If this is not practical, replace the assembly with the safety plug installed. This will reduce radiation dose to the fingers and also ensure proper positioning of the assembly. Avoid placing fingers over or near the S-tube opening during the replacement of the assembly.

10. Perform the SPEC-150 Operation Check referenced in Section 7.2.6 of the SPEC-150 User's Manual to verify that the replacement module was installed properly and that all exposure device functions are normal BEFORE installing the active source assembly.

8.6 Outlet Panel Assembly

The Outlet Panel Assembly must be replaced as needed due to wear or damage. No routine maintenance is required. Replacement is expected to be required every two to five years. If the outlet nipple must be replaced, it is necessary to replace the assembly. The outlet nipple cannot be removed by the user. A special tool is provided by SPEC to replace the panel. It is recommended that access to the special tool be controlled by the Radiation Safety Officer.

NOTICE

The outlet nipple installed in the carrying handle is NOT a replacement for the outlet nipple in the Outlet Panel Assembly.

8.6.1 Outlet Panel Assembly Replacement Procedures

1. Remove the four (4) security screws using the special tool provided.
2. Thoroughly clean the screws of any dirt, grit or foreign matter.
3. Install the replacement Outlet Panel Assembly with the safety plug installed.
4. Once the four (4) tamper-resistant screws have been cleaned, insert and tighten into the outlet end plate using the special tool provided.

CAUTION

TO PREVENT UNNECESSARY RADIATION DOSE TO THE EYES, DO NOT PUT EYES WITHIN TWO (2) FEET WHILE IN ALIGNMENT WITH THE S-TUBE OPENINGS WHEN AN ACTIVE SOURCE IS INSIDE THE DEVICE.

8.7 Lock Cap, Safety Plug, Key and Control Adaptor

NOTICE

DO NOT REPLACE THE FOUR (4) TAMPER-RESISTANT SCREWS WITH ANY OTHER TYPE OF FASTENER. THE SPEC-150 IS LICENSED AS A TYPE B(U) CONTAINER AND MODIFICATIONS ARE PROHIBITED.

These parts should be cleaned as needed to remain free of dirt, grease, grit and other foreign matter. It may be necessary to flush foreign matter from these components to provide proper operation. This may be done by using a brush, compressed air, pressurized water, detergent bath, or by spraying the component with a mild, aerosol, cleaning solvent. Aerosol solvents should be used with caution to prevent spraying into any opening of the SPEC-150 exposure device. Any excess or residue water or cleaning fluid should be removed.

The adaptor and key have a rubber O-ring seal to limit ingress of foreign material. The seals must be replaced annually or more often if a visual inspection detects cracks or other damage. The old O-ring can be removed without the use of special tools. The replacement O-rings should be installed by hand to avoid damage by the use of sharp tools.

CAUTION

THE INSPECTOR SHOULD WASH HANDS THOROUGHLY AFTER HANDLING THESE COMPONENTS TO REMOVE ANY SOLVENTS AND POTENTIAL DU AND IR-192 RADIOACTIVE CONTAMINATION.

8.8 Radiation Profile Survey Procedures

A survey should be performed on a quarterly basis to determine if the SPEC-150 exposure device meets the radiation level limits specified in ANSI N432-1980. The radiation levels must not exceed 200 mR/hr at the surface of the device and 2 mR/hr at 1 meter from the surface of the device when extrapolated to 150 curies.

By using a calibrated and properly operating survey meter, measure the radiation levels by scanning the entire surface of the device. Record the highest level at each surface. Survey at one meter from the highest readings at each surface. Extrapolate the readings to 150 curies. Determine if the adjusted readings exceed the regulatory limits or the levels recorded on the QA Inspection Certificate when the device was manufactured. Notify the Radiation Safety Officer if any discrepancies are detected.

8.9 G-60 Source Assembly

REPAIRS MAY NOT BE PERFORMED TO THE SOURCE ASSEMBLY, INCLUDING THE CONNECTOR, BY THE USER. DEFECTS OR MALFUNCTIONS MUST BE REPORTED IMMEDIATELY TO THE RADIATION SAFETY OFFICER.

The connector should be cleaned with a brush and mild cleaning solvent as needed to remove foreign material.

8.10 Control Assembly / Drive Cable Maintenance and Repair

Replacement parts and components are available from SPEC. Unauthorized replacement parts should not be used. It is recommended that licensees consult the NRC or Agreement State licensing agency to determine which replacement parts from other manufacturers are authorized for use.

Parts that require a manufacturing process to install, such as fittings to be crimped, are not available as replacement components. Repairs that require a special process must be done under the control of an authorized Quality Assurance program.

8.10.1 Control Assembly Disassembly

This section provides step-by-step procedures to disassemble and clean the control assembly. It is recommended that these procedures be conducted on a quarterly basis and any time maintenance or repairs are required. The Daily Safety Inspection Procedures, Section 7.1.4 and the SPEC-150 System Operational Check, Section 7.2.6, should be performed after this procedure.

1. Remove the drive cable from the control assembly by cranking it out until it automatically stops.
2. Cut off the tie wraps or tape and remove any fasteners that binds the conduits together.
3. Unscrew the return conduit (bottom) from the pistol assembly. Conduits are attached to the pistol housing with a swivel adaptor to provide easy removal.
4. After the return conduit is removed from the pistol assembly, retract the drive cable approximately 1 foot.
5. Remove the cable stop from the end of the drive cable by rotating the cable stop. The cable stop will unscrew from the coils (spirals) of the drive cable.
6. Crank the drive cable forward until it passes completely through the gear. Manually pull the remaining drive cable through the control adaptor.
7. Remove the drive conduit (top) from the control pistol by unscrewing.
8. Unscrew the Control Adaptor from the other end of the conduit.
9. Remove the three (3) screws from the side of the pistol assembly cover plate.

10. Remove the cover plate from the control pistol. The crank arm, gear/shaft assembly, and cover plate bearing will be attached to the cover plate.
11. Use a bearing puller to remove the bearing from the inside of the pistol housing, if needed.

8.10.2 Control Assembly Internal Component Inspection

Components that are not accessible to inspection on a daily basis should be closely inspected for wear and defects when the equipment is disassembled.

Control Pistol Assembly

1. Verify that both bearings rotate freely.
2. Check that there are no broken teeth in the gear and that the gear is securely attached to the shaft.
3. The shaft should fit snugly into the cover plate bearing.
4. Inspect the drive cable path around the inside of the pistol housing for excessive wear that can allow the drive cable to skip on the gear when cranking out.

8.10.3 Control Assembly Cleaning Procedures

Use a brush and cloth with mild solvent to clean dirt, debris and foreign material off all components, excluding the drive cable. Do not use lubricants. It is NOT recommended to spray with liquids or use compressed air. These methods are effective for cleaning, but they can cause trace amounts of IR-192 or depleted uranium contamination to be released. It is very unlikely that the control conduits (sheaths) will require cleaning. However, if they must be cleaned, compressed air may be used only after taking all necessary safety precautions to protect against exposure, injection or inhalation of potential airborne contamination.

8.10.4 Drive Cable Maintenance and Cleaning Procedure

Maintenance of the drive cable is VERY CRITICAL to the safe operation of the system. Poorly maintained drive cables have been the cause of many system malfunctions which have lead to radiation overexposures. The following information is provided to users of Source Production and Equipment Company controls with Teleflex 5222 drive cables. The cleaning and lubrication information was developed by Triumph Controls, Inc., North Wales, PA. SPEC makes no claims as to the suitability of this procedure and offers no other warranties except those expressly contained in SPEC purchase documents.

TOOLS/MATERIALS REQUIRED:

-Dow Corning DC33 Silicone Grease (Light Consistency)

- Houghto-quench G lubricant by Houghton International, Inc.
- A degreaser such as Varsol or Mineral Spirits
- Access to compressed air
- A hard bristle brush
- A galvanized 10/20 gallon tub for lubrication soaking.
- A galvanized 10/20 gallon tub or a standard parts washer for cleaning the cable
- Clean rags

SAFETY:

The degreaser specified is a combustible liquid and emits combustible vapors. Consult the Material Safety Data Sheets on the degreaser used as well as the other materials used in this procedure and take the necessary precautions for handling, breathing, ventilation and disposal.

PROCEDURE:

New Cable:

Before inserting the drive cable into the drive conduit, lubricate the cable with Dow Corning DC33 Silicone Grease (Light Consistency). The grease will be applied by hand and should fill approximately 1/3 of the space between the core and the spiral wrap. Remove excess by running the drive cable through a clean hand held rag.

Used Cable:

Follow the following steps for inspection, cleaning and lubricating:

Disassemble the controls and remove the drive cable from the conduit. Visually inspect and reject the cable for damage such as unwinding, nicks which would cause a stress point or excessive rust which would cause embrittlement. Check for embrittlement/flexibility and stress points by curling at any point suspected into a 3" diameter coil. Anywhere along the length of the cable should pass this test without bending or kinking. A light coat of surface rust is acceptable provided the flexibility is not affected.

Cables which are acceptable should be coiled and placed into a cleaning tub. Pour degreaser into the cleaning tub. Fill the tub enough to cover the drive cable plus ½ inch. Let the cable soak in the degreaser for approximately 1 hour, shaking the cable vigorously every 15 minutes to dislodge dirt and work the degreaser into the cable. Run a stiff bristle brush over the cable to dislodge any loose particles. Dip the cable back into the degreaser and agitate it vigorously for one minute. Lay the cable out on a flat surface and dry it thoroughly with compressed air.

Coil the cable and place it into the galvanized lube tub. Pour enough Houghto-quench G into the tub to completely cover the drive cable. Soak the cable in the lubricant for at least ½ hour. Remove the coil of cable and suspend it above the tub for at least 4 hours, to

drain the excess lubricant. Excess lubricant may also be spun out of the cable by use of a centrifuge for 3 minutes. Blow Excess oil from cable using oil free air, not exceeding 25 psi. Wipe cable with a dry, clean, lint free cloth.

Lubricate the cable with Dow Corning DC33 Silicone Grease (Light consistency). The grease will be applied by hand and should fill approximately 1/3 of the space between the core and the spiral wrap. Remove excess grease by running the drive cable through a clean hand held rag.

CAUTION

THE INSPECTOR SHOULD WASH HANDS THOROUGHLY AFTER HANDLING THESE COMPONENTS TO REMOVE ANY SOLVENTS AND POTENTIAL DU AND IR-192 RADIOACTIVE CONTAMINATION.

8.10.4 Control Re-assembly Procedure

1. Slip the bearing back into the pistol housing.
2. Install the gear/shaft assembly and cover plate onto the pistol housing.
3. Using the three (3) stainless steel screws, attach the cover plate to the pistol housing.
4. Screw the drive conduit (top) into the pistol housing until it is firmly attached.
5. Attach the control adaptor to the opposite end of the top conduit.
6. Install the drive cable through the control adaptor and top conduit.
7. When the drive cable reaches the pistol housing, verify that the gear teeth mesh (align) with the end of the drive cable.
8. Crank the drive cable back until the drive cable feeds through the bottom side.
9. Install the cable stop onto the end of the drive cable by rotating the cable stop. Position the cable stop between 1/2" and 5/8" past the end of the drive cable.
10. Attach the bottom conduit to the pistol grip.
11. Crank the drive cable in completely.
12. Using tie wraps or some other method, attach the two conduits to each other, side by side. Space the tie wraps approximately 18" apart.

8.11 Guide Tube

See Daily Safety Inspection Procedures, Section 7.1.9.

Replacement of fittings that are attached directly to the guide tube by a manufacturing process such as crimping should be installed by the manufacturer or other licensee authorized by the NRC or Agreement State licensing agency.

9.0 **TRANSPORTATION PREPARATIONS**

9.1 Procedures for Preparing and Loading the Package

Training of personnel who prepare, transport, and offer for transport hazardous material shipments, including the model SPEC-150, is required pursuant to 49 CFR 172.700 and Section 10 of the Louisiana Radiation Regulations. The source assembly is loaded into the model SPEC-150 at the SPEC facilities under the provisions of Louisiana Radioactive Material License LA-2966-L01 in accordance with the procedures and radiation protection standards established under that license.

9.1.1 General Package Inspection

Visually inspect the model SPEC-150 to determine if it is in unimpaired condition for the shipment. Visual check all external fasteners and welds. The model SPEC-150 should be inspected to verify that it is not damaged, that the lock operates properly, that the source assembly (pigtail) is securely locked in the package, and that the safety plug and lock cap are securely positioned. Verify that the package identification plate is present and legible, which identifies the package as a model SPEC-150 and displays the Certificate of Compliance identification number.

9.1.2 Packaging

Verify that the source assembly is properly secured and locked in the model SPEC-150. The safety plug and the lock cap must be firmly attached. Measure the maximum surface radiation level and the maximum radiation level at one meter from the surface of the package. The maximum surface radiation level must not exceed 200 mrem/hr. Although it is permissible for the maximum radiation level at one meter from the surface of the package to not exceed 10 mrem/hr, the maximum radiation level at one meter for the surface of the SPEC-150 should not exceed 2 mrem/hr. If the lock key is to be shipped in the same container with the camera, then seal the lock key in an envelope which will be destroyed when opened.

9.1.3 Outer Package Surface Contamination

Packages may not be shipped on a non-exclusive use basis with outer surface contamination levels exceeding those published in 49 CFR 143.443. It is the shipper's responsibility to ensure that contamination limits are met. The regulatory limit for non-

fixed (removable) contamination on the external surfaces of an outer package being shipped on a non-exclusive use basis is 10^{-4} $\mu\text{Ci}/\text{cm}^2$ (4 Bq/cm² or 220 dpm/cm²). This may be determined by wiping 300 cm² from representative locations, dividing the activity found by the surface area wiped (in cm²), and dividing by the efficiency of the wipe. For this purpose, the actual wipe efficiency may be used, or the wipe efficiency may be assumed to be 0.10. If the contamination on the surface of the outer package exceeds the above amount, it must not be shipped.

9.1.4 Transportation Requirements

The model SPEC-150 package must be properly marked, labeled and described on a shipping paper in accordance with U.S. Department of Transportation regulations. Placards will be offered to carriers transporting a Radioactive Yellow III labeled package. Shipping papers will be retained for three years in accordance with regulations.

9.1.5 Type B Quantity Consignee Notification

Prior to each shipment of a model SPEC-150 containing more than 27 Ci Iridium-192, the shipper shall notify the consignee of the dates of shipment and expected arrival.

9.2 Procedures for Receipt and Unloading the Package

9.2.1 Unloading the SPEC-150

The consignee must establish written procedures for receiving the model SPEC-150 package in accordance with applicable NRC and agreement state regulations. Such procedures should provide for inspection, monitoring, notification and records. The model SPEC-150 package becomes an industrial radiography exposure device after receipt by the licensed industrial radiography user. The source assembly is temporarily removed and then returned to the exposure device frequently throughout its use in accordance with the licensed user's procedures and in accordance with applicable NRC or agreement state regulations.

9.2.2 Receiving the SPEC-150

1. Delivery, Pick Up and Acceptance from Carrier

Regulations require that the consignee make arrangements to receive the model SPEC-150 when it is offered for delivery by the carrier; or must make arrangements to receive notification from the carrier at the time of arrival for pick up at the carrier's facility. The consignee must expeditiously pick up the model SPEC-150 upon receipt of notification from the carrier.

2. Receipt Survey and Inspection

Before the delivered package is opened and as soon as practicable after receiving the model SPEC-150, but no later than three hours after it is received at the consignee's facility during normal working hours or within three hours beginning the next work day if received after normal working hours, the package must be monitored and inspected. The outside package, as received, should be inspected for any indication of damage to the model SPEC-150, and the maximum external radiation levels at the surface of the outside package and at one meter from the surface of the outside package must be measured and recorded. Dents and abrasions to the overpack normally encountered in handling, loading and unloading are not generally considered evidence of damage to the model SPEC-150.

Since the sealed source in the model SPEC-150 is classified as special form radioactive material, it is not required to monitor the external surfaces of the outside package for removable contamination.

SPEC recommends that the SPEC-150 System Operational Check Procedures in Section 7.2.6 be conducted before the first use of a new unit to verify that it was not damaged in transport.

3. Notification

If the measured maximum radiation levels exceed 200 mrem/hr at the surface of the outside package or 10 mrem/hr at one meter from the surface of the outside package, the consignee must immediately notify the final delivering carrier, and either the agreement state radiation control agency, if applicable, or the NRC regional office having jurisdiction over the location where the package was received. It is also recommended that the shipper be notified. Care should be exercised in performing the survey to ensure that the radiation levels are measured at the proper distances, that the survey meter is calibrated and operating properly, and that the stated accuracy of the survey meter be considered.

4. Records

Records of the receiving survey should be maintained for a period of three (3) years. These records should include at least:

- a. the date and time the package was received or picked up;
- b. the date and time it was monitored;
- c. the identification of package by serial number;
- d. identification of source by serial number, isotope and activity (includes date of measurement);
- e. identification of individual performing survey;

- f. identification of survey meter by serial number;
- g. maximum radiation levels at surface of outside package and at one (1) meter from surface of outside package; and
- h. corrective action and notification to carrier and regulatory agency, if applicable.

9.3 Preparation of an Empty Package for Transport

If the source assembly has been removed from the model SPEC-150, the packaging must be surveyed to ensure that it does not contain a radioactive source or that there is no contamination in excess of the 100 times the outer package surface contamination limits specified above.

Test to verify that the SPEC-150 does not contain a radioactive source (authorized source, unauthorized source, modified source, or a source capsule that has been removed from the source assembly) by the following method. This test should be performed by authorized and monitored personnel who have been trained in radiation safety and equipped with a properly operating survey instrument.

First; remove the safety plug and survey the open outlet nipple. The depleted uranium shield is radioactive and will emit radiation even when no sealed source is installed in the package, but the highest radiation level should not exceed approximately 2 mR/hr. Second; remove the lock cap and visually inspect the device to verify that no source assembly connector is protruding. Third; attach the control assembly to the device and crank the drive cable forward two complete revolutions while monitoring the survey instrument for radiation hazards. An exposed source must be treated as an emergency. Fourth; crank the drive cable back, disconnect and remove the control assembly from the device, and install the safety plug and lock cap. As an option, before cranking the drive cable back, a dummy connector or a dummy source assembly may be attached to the drive cable and retracted into the device. If a dummy connector is used it will pull out of the device with the drive cable when the controls are removed. If a dummy source assembly is used it will remain in the device and must be disconnected from the control drive cable to remove the controls. Inspect the connector of the dummy source assembly to verify that it has no serial number.

The empty packaging contains 37 pounds of depleted uranium and may be shipped as either labeled radioactive material package or as an excepted package as required by applicable U.S. Department of Transportation regulations.

APPENDIX

Description	Drawing #
ASM / Lock Module Assembly	190905 (0)
Automatic Unsecuring Sequence	150650 (3)
Control Adaptor Assembly #1	151410-A (3)
Control Assembly Setup Sequence	Cass (1)
Dummy Source Assembly, G-60	151210-1 (2)
Lock Cap Assembly	190903 (0)
Outlet Panel Assembly	150406-1 (0)
Safety Plug Assembly	190908 (0)
Sectional View (w/shield)	150002A (2)
Source Lock Operation	15B511 (1)
SPEC-150 Exposure Device	15B000 (10)

CONTROLLED COPY NO			
REVISIONS			
REV	DESCRIPTION	DATE	APPROVED

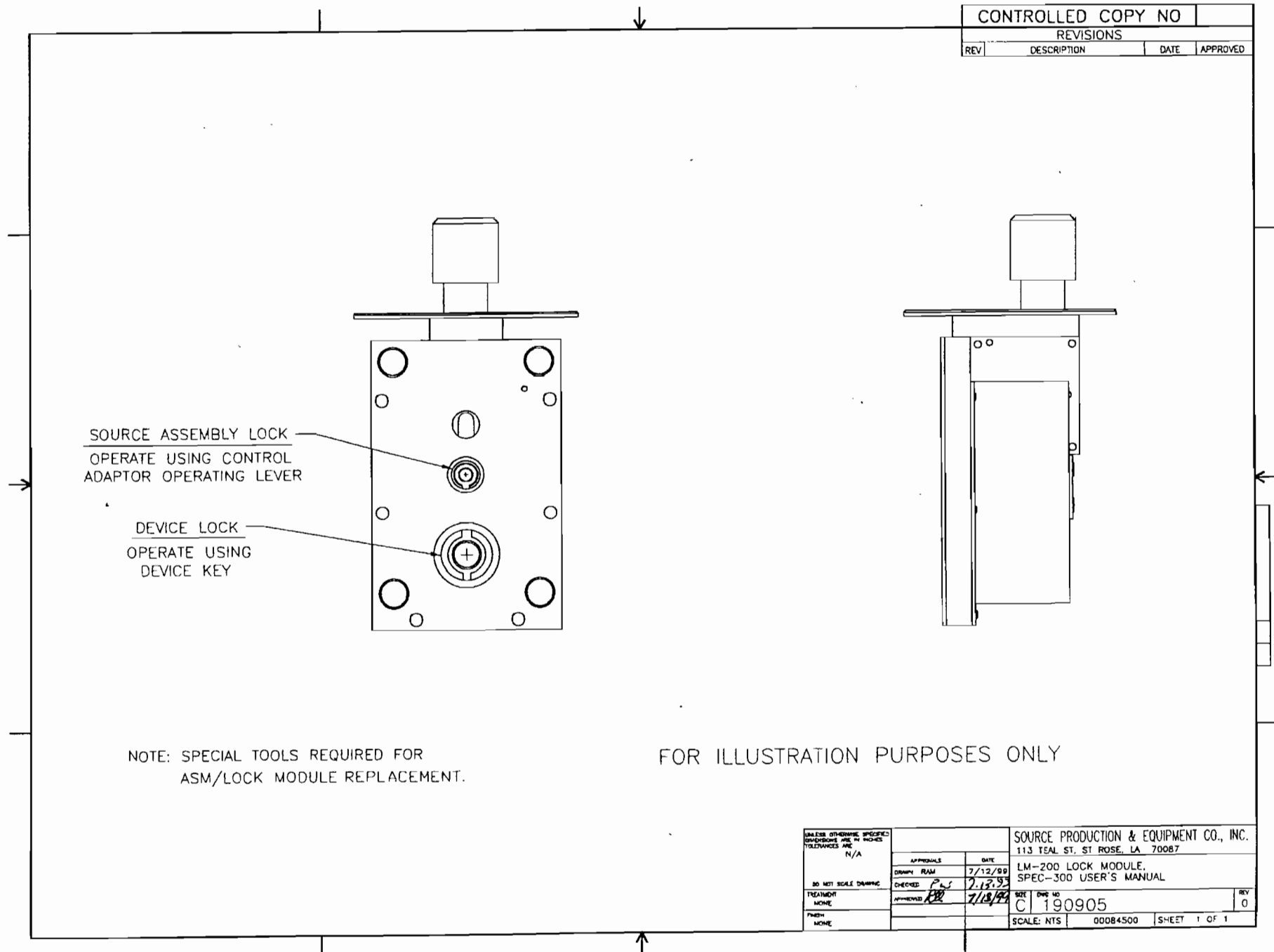

UNLESS OTHERWISE SPECIFIED: DIMENSIONS ARE IN INCHES TOLERANCES ARE N/A		APPROVALS DRAWN: <i>RAM</i> CHECKED: <i>PLJ</i> APPROVED: <i>PLJ</i>		DATE 7/12/99 7/12/99 7/18/99		SOURCE PRODUCTION & EQUIPMENT CO., INC. 113 TEAL ST. ST ROSE, LA 70087 LM-200 LOCK MODULE, SPEC-300 USER'S MANUAL	
DO NOT SCALE DRAWING	TREATMENT NONE	FINISH NONE	SIZE C	DWG NO 190905	REV 0	SCALE: NTS	00084500 SHEET 1 OF 1

CONTROLLED COPY # _____

REVISIONS

REV	DESCRIPTION	DATE	APPROVED
(3)	ECR# 970811-4 CHANGE DRAWING TITLE TO READ AUTOMATIC UNSECURING SEQUENCE. CHANGE DRAWING NUMBER TO CORRESPOND WITH THE SPEC-150 NUMBERING SYSTEM.	10-1-97 10-14-97	S. BYRD PW

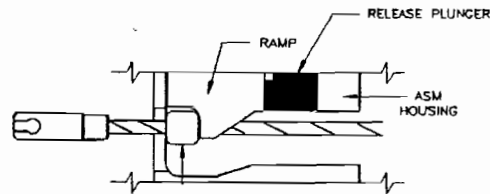

① SECURED

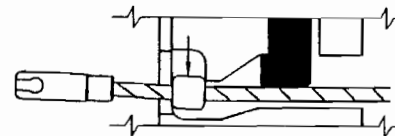

② UNSECURED
(RELEASE PLUNGER LATCHED DOWN)

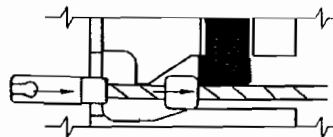

③ CRANKING FORWARD
(UNLATCHING RELEASE PLUNGER)

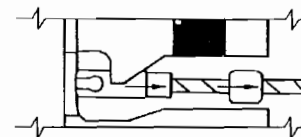

④ CRANKING FORWARD
(TO EXPOSE SOURCE)

UNLESS OTHERWISE SPECIFIED DIMENSIONS ARE IN INCHES TOLERANCES ARE		APPROVALS		DATE		SOURCE PRODUCTION & EQUIPMENT CO, INC 113 TEAL ST, ST ROSE, LA 70087	
FRACTIONS	DECIMALS	DRAWN SRB		7-14-95		ASM - AUTOMATIC UNSECURING SEQUENCE SPEC-150 EXPOSURE DEVICE	
	.XXX.XX .XXXX.010	CHECKED PW		10-14-97		SIZE DWG NO B 150650	
DO NOT SCALE DRAWING		ISSUED RDD				REV 3	
TREATMENT NONE		QA CLASS		N/A		SCALE: 1:1	
FINISH NONE						00031503 SHEET 1 OF 1	

CONTROLLED COPY NO			
REVISIONS			
REV	DESCRIPTION	DATE	APPROVED
(3)	INCORPORATED ECR#: 040809-1.	8/11/04 6/15/04 6/15/04	T. RUIZ RCA RCA

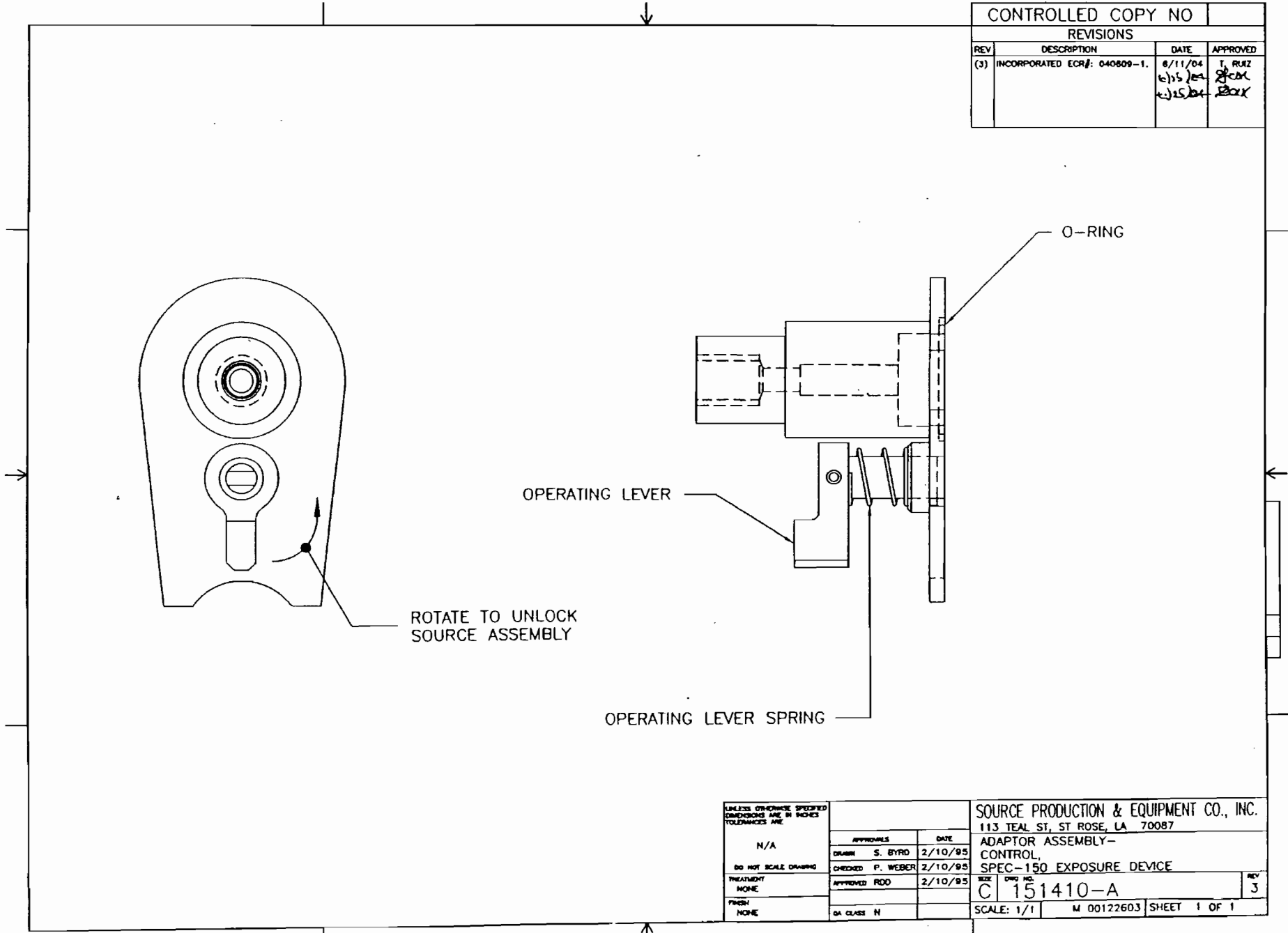

UNLESS OTHERWISE SPECIFIED DIMENSIONS ARE IN INCHES TOLERANCES ARE		SOURCE PRODUCTION & EQUIPMENT CO., INC. 113 TEAL ST, ST ROSE, LA 70087	
N/A	APPROVALS	DATE	ADAPTOR ASSEMBLY- CONTROL, SPEC-150 EXPOSURE DEVICE
DO NOT SCALE DRAWING	DRAWN S. BYRD	2/10/95	
TREATMENT NONE	CHECKED P. WEBER	2/10/95	
FINISH NONE	APPROVED ROD	2/10/95	
	QA CLASS N		SCALE: 1/1 M 00122603 SHEET 1 OF 1
			REV 3

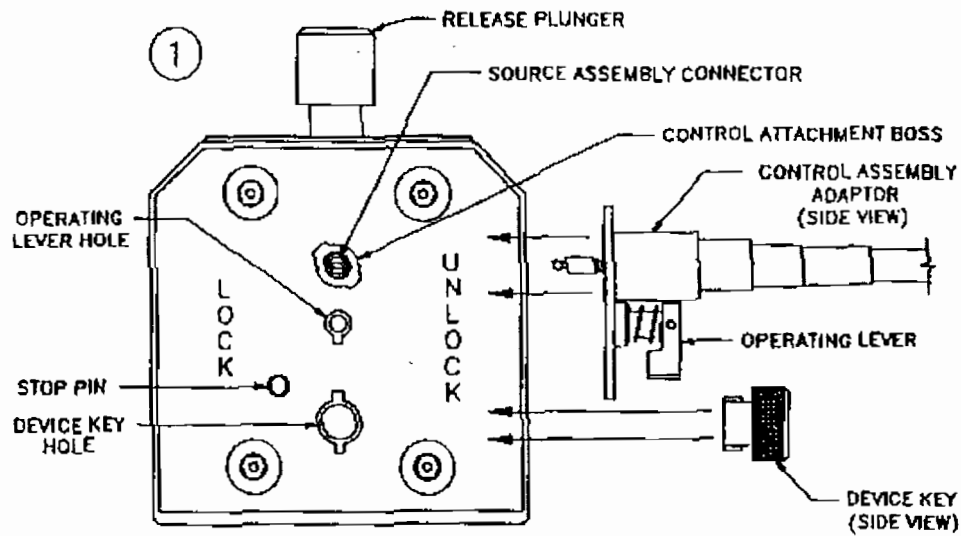

STEPS:

- # 1. ATTACH DRIVE CABLE TO SOURCE ASSEMBLY. ①
- # 2. ATTACH CONTROL ADAPTOR TO ATTACHMENT BOSS. ②
- # 3. ROTATE CONTROL ADAPTOR AGAINST STOP PIN. ②
- # 4. INSERT DEVICE KEY AND ROTATE CLOCKWISE. ③
- # 5. INSERT OPERATING LEVER AND ROTATE COUNTER CLOCKWISE. ③

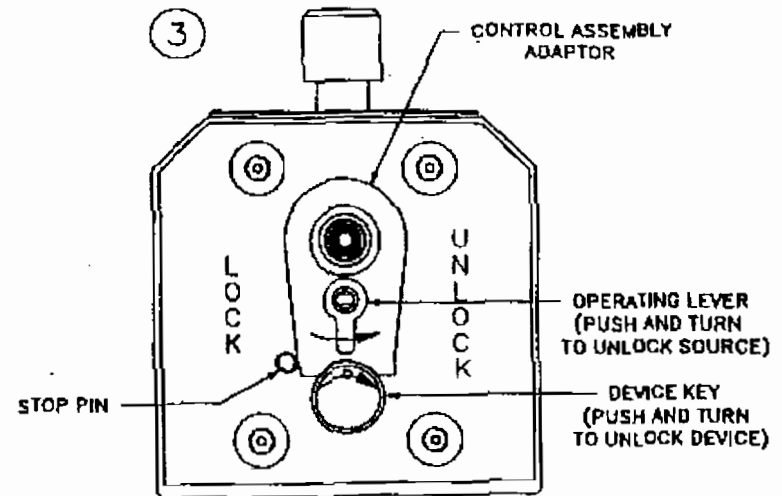
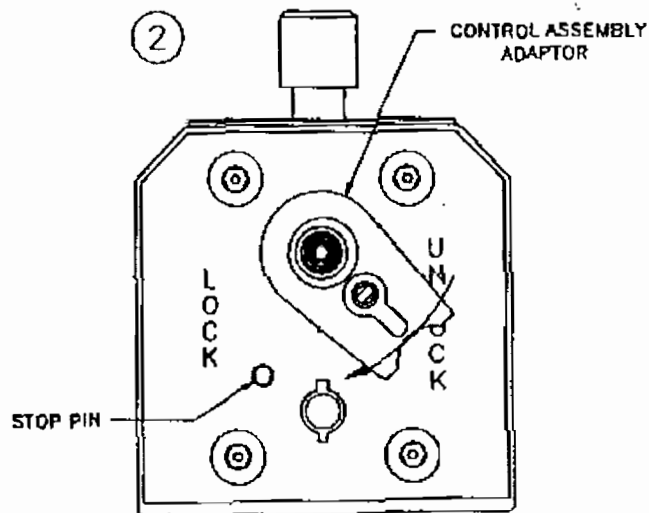

CONTROLLED COPY NO			
REVISIONS			
REV	DESCRIPTION	DATE	APPROVED
(2)	INCORPORATED ECR#: 040609-3.	8/14/04	TMR <i>(Signature)</i>
		8/10/04 8/24/04	<i>(Signature)</i> <i>(Signature)</i>

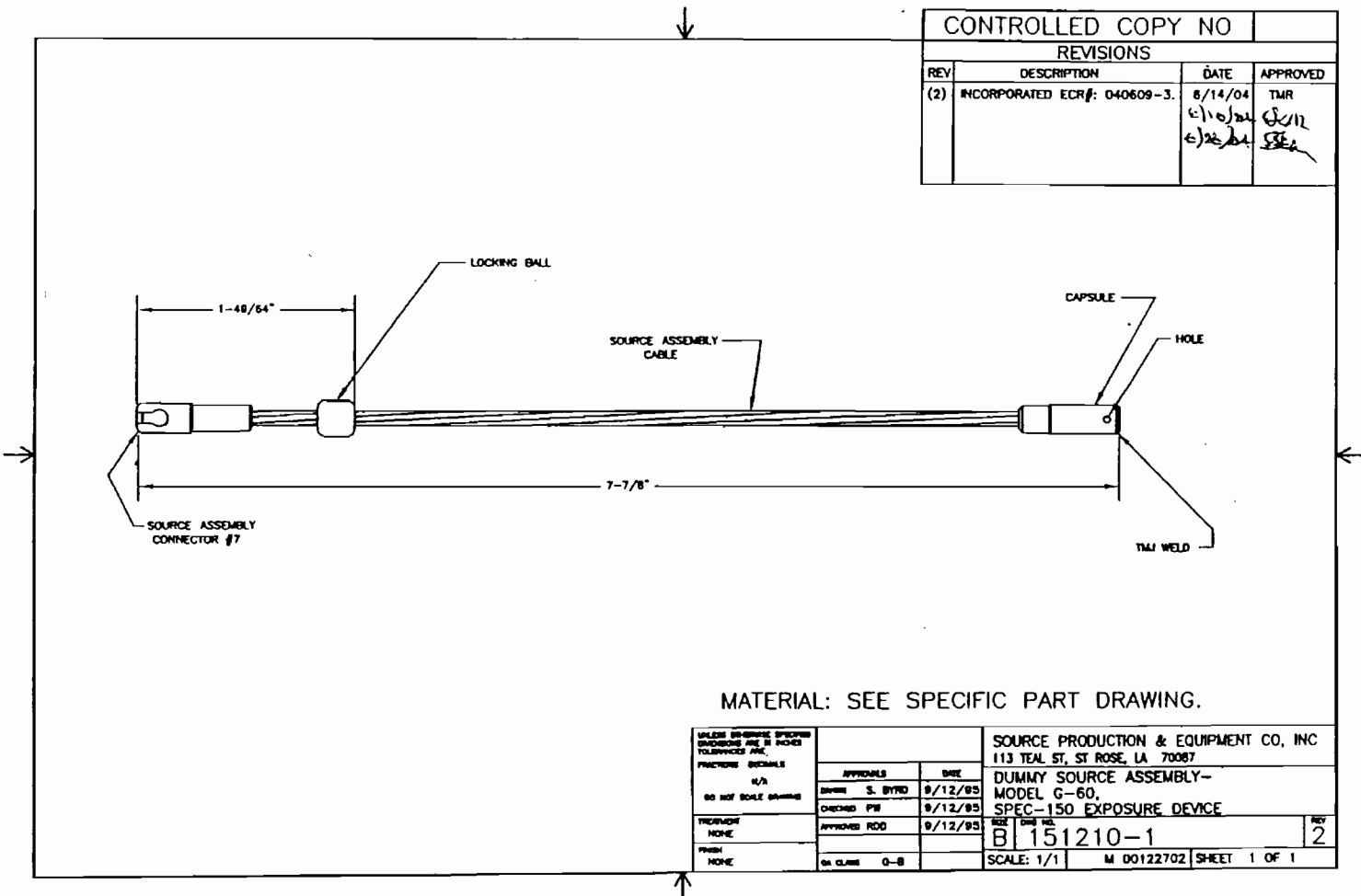

MATERIAL: SEE SPECIFIC PART DRAWING.

UNLESS OTHERWISE SPECIFIED DIMENSIONS ARE IN INCHES FRACTIONS DECIMALS		SOURCE PRODUCTION & EQUIPMENT CO, INC 113 TEAL ST, ST ROSE, LA 70087	
MATERIAL	APPROVALS	DATE	DUMMY SOURCE ASSEMBLY- MODEL G-60, SPEC-150 EXPOSURE DEVICE
FINISH	DESIGNED BY	9/12/95	
OTHER	CHECKED BY	9/12/95	
	APPROVED RCD	9/12/95	SCALE: 1/1
	QA CLASS	0-B	M 00122702 SHEET 1 OF 1

CONTROLLED COPY NO			
REVISIONS			
REV	DESCRIPTION	DATE	APPROVED

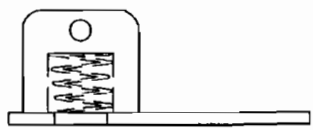
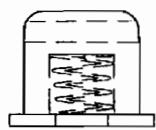
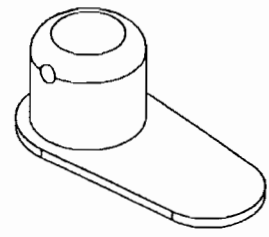

FOR ILLUSTRATION PURPOSES ONLY

UNLESS OTHERWISE SPECIFIED DIMENSIONS ARE IN INCHES TOLERANCES ARE:		SOURCE PRODUCTION & EQUIPMENT CO., INC. 113 TEAL ST. ST ROSE, LA 70087	
	N/A	APPROVAL	DATE
DO NOT SCALE DRAWING		DRAWN RAN	7/12/89
TREATMENT		CHECKED <i>PW</i>	7.13.89
FINISH		APPROVED <i>[Signature]</i>	7/13/89
		SIZE	DWG NO.
		C	190903
		SCALE: 1/1	00084000 SHEET 1 OF 1
			REV 0

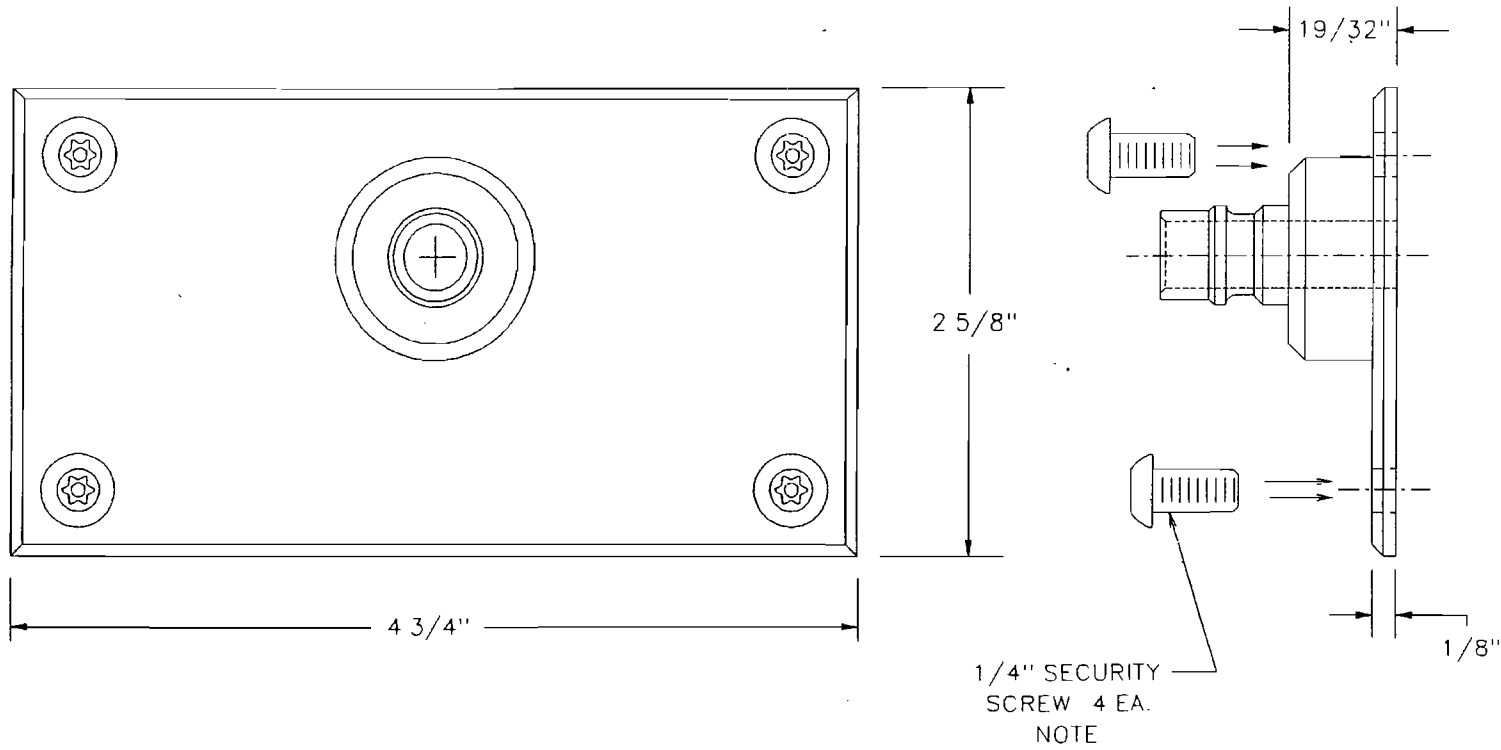

MATERIAL:
 PANEL & BOSS: TITANIUM
 OUTLET NIPPLE: STAINLESS STEEL

NOTE: SPECIAL TOOL REQUIRED.

TOLERANCES		REVISIONS			SOURCE PRODUCTION & EQUIPMENT CO., INC 113 TEAL ST., ST. ROSE, LA. 70087		
(EXCEPT AS NOTED)	#	DATE	DWG BY	APP'D BY	SPEC 150 EXPOSURE DEVICE OUTLET PANEL ASSEMBLY		
DECIMAL	1				DRAWN BY	SCALE	MATERIAL
+/- N/A	2				S. BYRD	1 TO 1	NOTED
FRACTIONAL	3				CHK'D BY	DATE	DRAWING NO.
+/-	4				10/2/94	9-7-94	150406-1
ANGULAR	5				Q.A. CLASS.	APP'D BY	REV. (0)
+/-					Q-B	<i>[Signature]</i>	

CONTROLLED COPY NO			
REVISIONS			
REV	DESCRIPTION	DATE	APPROVED

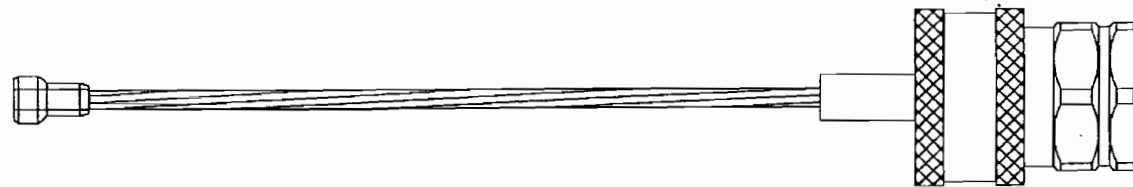

FOR ILLUSTRATION PURPOSES ONLY

UNLESS OTHERWISE SPECIFIED DIMENSIONS ARE IN INCHES TOLERANCES ARE N/A		APPROVALS		DATE		SOURCE PRODUCTION & EQUIPMENT CO., INC. 113 TEAL ST, ST ROSE, LA 70087	
DO NOT SCALE DRAWING		DESIGN	RAM	2/12/99	SAFETY PLUG ASSEMBLY, SPEC-300 USER'S MANUAL		
TREATMENT NONE		CHECKED	<i>[Signature]</i>	2.13.99	SIZE	DWG NO.	REV
FINISH NONE		APPROVED	<i>[Signature]</i>	7/13/99	C	190908	0
		SCALE: NTS		000B4B00	SHEET 1 OF 1		

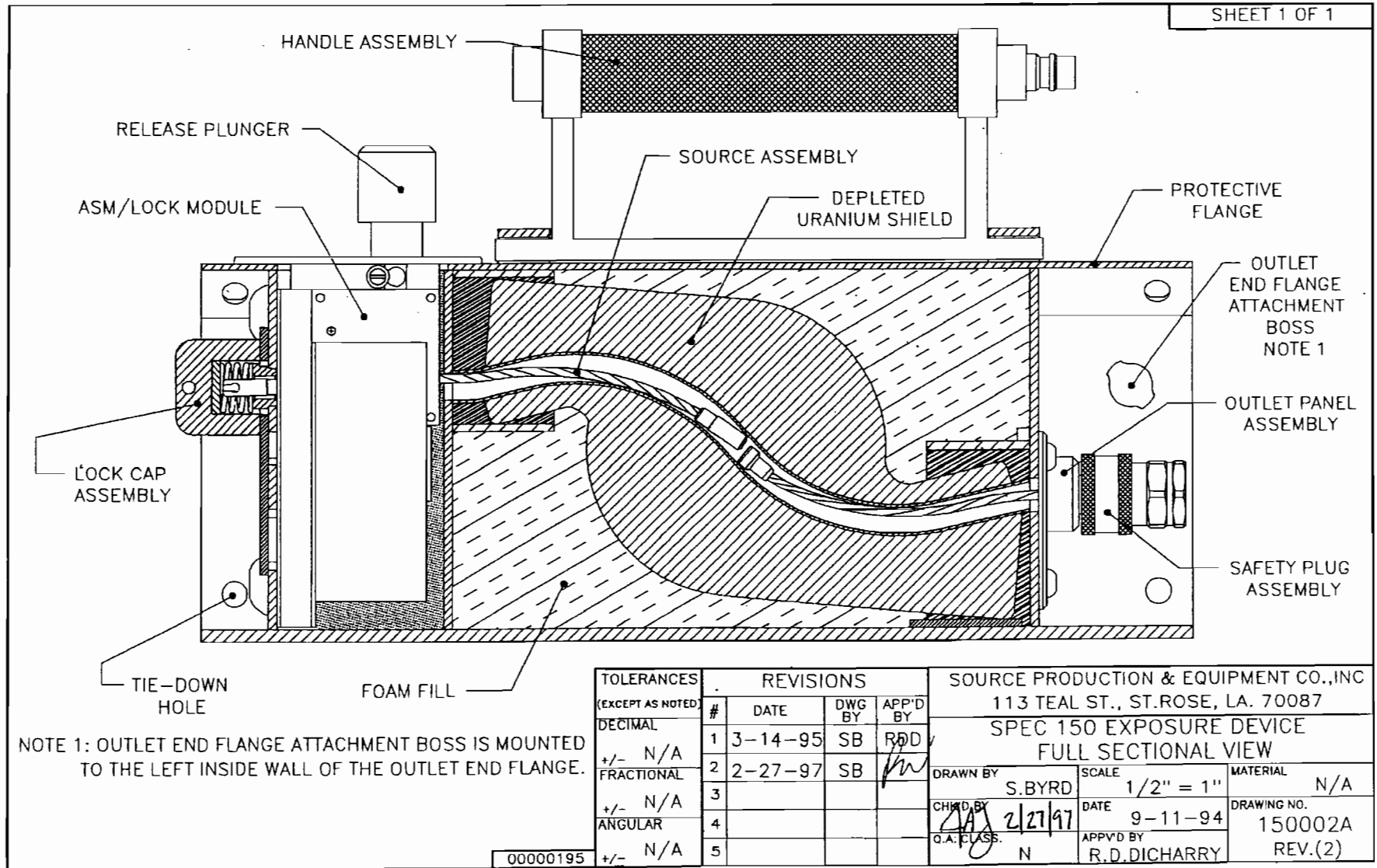

NOTE 1: OUTLET END FLANGE ATTACHMENT BOSS IS MOUNTED TO THE LEFT INSIDE WALL OF THE OUTLET END FLANGE.

TOLERANCES (EXCEPT AS NOTED)		REVISIONS			SOURCE PRODUCTION & EQUIPMENT CO., INC 113 TEAL ST., ST. ROSE, LA. 70087		
		#	DATE	DWG BY	APP'D BY		
DECIMAL		1	3-14-95	SB	RDD	SPEC 150 EXPOSURE DEVICE	
+/-	N/A	2	2-27-97	SB	<i>[Signature]</i>	FULL SECTIONAL VIEW	
FRACTIONAL		3				DRAWN BY	SCALE
+/-	N/A					S. BYRD	1/2" = 1"
ANGULAR		4				DATE	MATERIAL
+/-	N/A	5				9-11-94	N/A
						APP'D BY	DRAWING NO.
						R.D. DICHARRY	150002A
							REV.(2)

00000195

CONTROLLED COPY NO			
REVISIONS			
REV	DESCRIPTION	DATE	APPROVED
(1)	INCORPORATED ECR#: 040609-4.	06/15/02 6/15/02	TMR <i>[Signature]</i>

NOTES:

1. VIEWS ARE FROM THE LOCK END OF THE DEVICE.
2. SOURCE ASSEMBLY CONNECTOR.
3. LOCKING BALL.

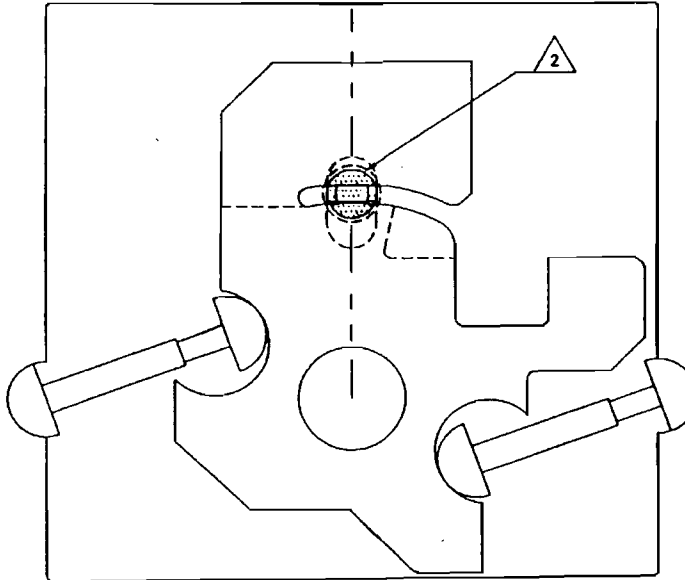

"SOURCE LOCK CLOSED"

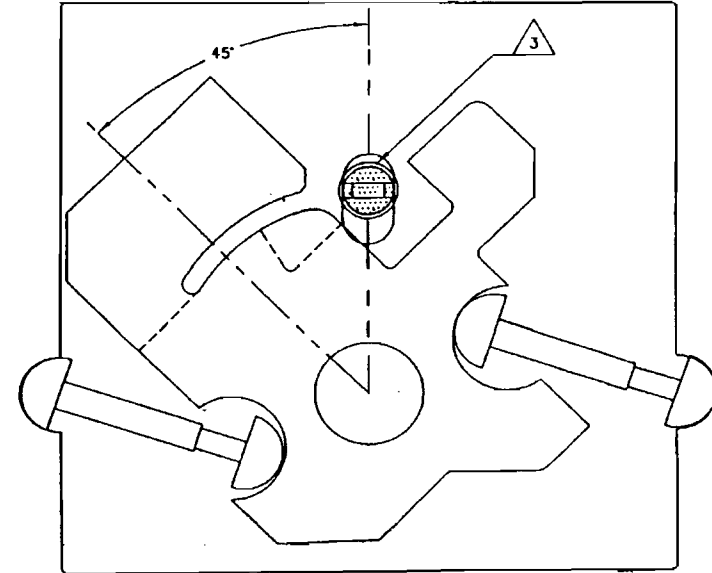

"SOURCE LOCK OPEN"

CHECKED N/A NO NEW HOLE DRAWING WEIGHT NONE FINISH NONE	APPROVALS CHECKED N/A APPROVED N/A	DATE 3/2/03	SOURCE PRODUCTION & EQUIPMENT CO., INC. 113 TEAL ST, ST ROSE, LA 70087 OPERATION- SOURCE LOCK, SPFC-150 EXPOSURE DEVICE SIZE (SEE IT) C115B511	REV 1
	QA CLASS O-B	SCALE: 1/1		00122801 SHEET 1 OF 1

STATEMENTS OF FABRICATION:

- SUPPLEMENTAL SHIELDING, IF NEEDED TO MEET NORMAL CONDITION DOSE RATE LIMITS, IS ATTACHED TO THE SHIELD OR OTHER PACKAGE COMPONENTS USING ALUMINUM EPOXY POTTING COMPOUND. THE SUPPLEMENTAL SHIELDING CONSISTS OF ONE POUND OR LESS OF DEPLETED URANIUM, TUNGSTEN OR LEAD.
- MAXIMUM WEIGHT: 53.5 LBS.
- SEE DRAWING 15B001-3 FOR MATERIAL SPECIFICATIONS FOR SERIAL NUMBERS 1475 AND NEWER.
HOUSING COVER IS 3/32" THICK
OUTLET END SUPPORT CUP & BULKHEADS ARE 1/8" THICK
INNER SUPPORT CUP IS 2" NOMINAL SCHEDULE 10 PIPE
BOTTOM PLATE (BASE) IS 3/16" THICK

CONTROLLED COPY NO			
REVISIONS			
REV	DESCRIPTION	DATE	APPROVED
(1)	SEE QA FILE FOLDER 15B000.	3-6-95 3-6-95 3-6-95	S. BYRD KC RDD
(2)	SEE QA FILE FOLDER 15B000.	4-5-95 4-5-95 4-5-95	S. BYRD KC RDD
(3)	SEE QA FILE FOLDER 15B000.	4-14-95 4-14-95 4-14-95	S. BYRD KC RDD
(4)	SEE QA FILE FOLDER 15B000.	9-21-95 9-21-95 9-21-95	S. BYRD KC RDD
(5)	INCORPORATED ECR# 981007-02.	10-15-98 4-20-99 4-20-99	S. BYRD RAM RDD
(6)	INCORPORATED ECR# 990506-04	5-6-99 5-6-99 5-6-99	S. BYRD RAM RDD
(7)	INCORPORATED CR# 000166.	3-10-09 3-11-09 3-11-09	KP KR KR
ALL CHANGES ARE IN MQ1.		MQ1	MQ1

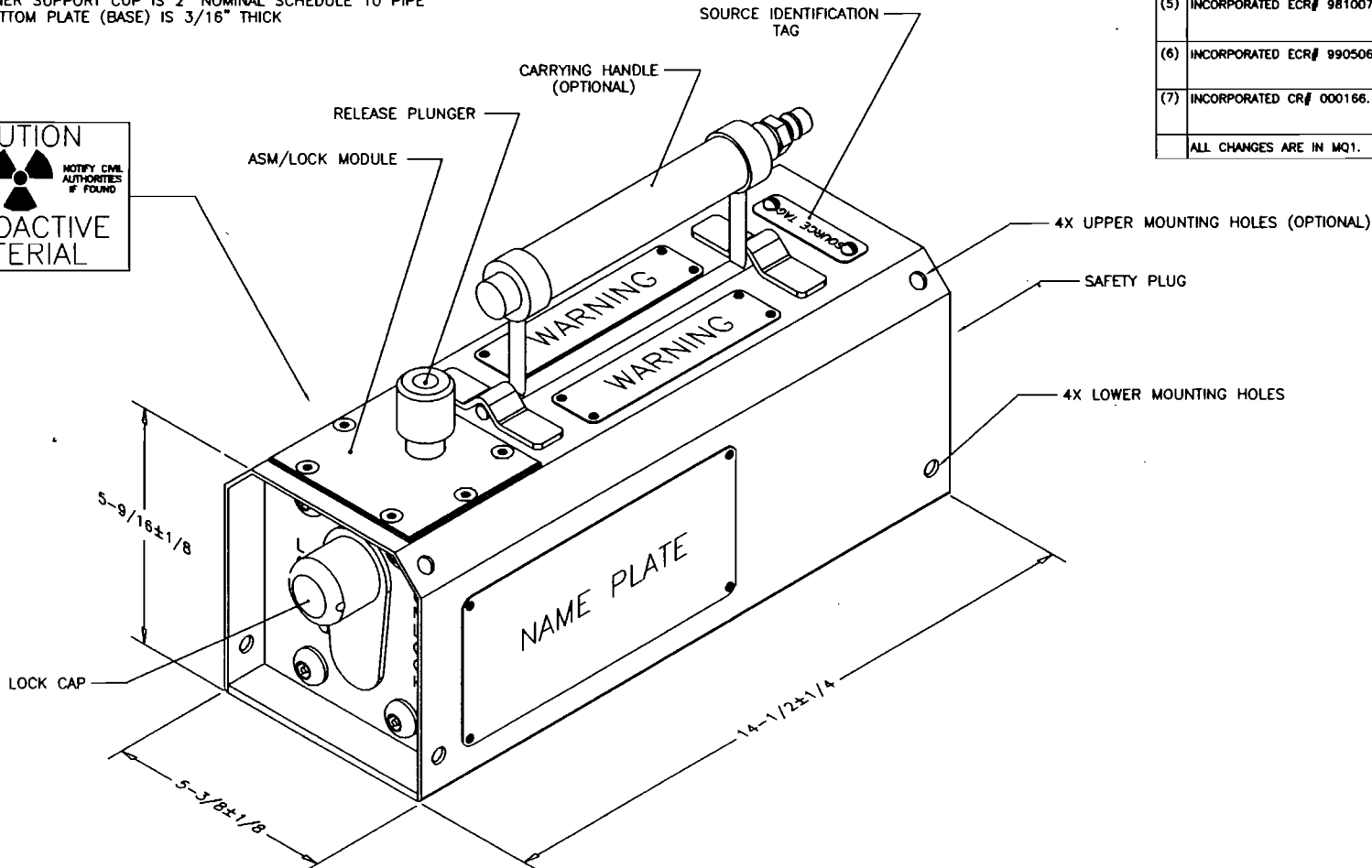

UNLESS OTHERWISE SPECIFIED DIMENSIONS ARE IN INCHES TOLERANCES ARE:		SOURCE PRODUCTION & EQUIPMENT CO., INC. 113 TEAL ST, ST ROSE, LA 70087	
AS NOTED	APPROVALS	DATE	
DO NOT SCALE DRAWING	DRAWN: KP	2-18-11	
TREATMENT: NONE	CHECKED: MQ1	MO 1	
FINISH: NONE	ISSUED: MQ1	MO 1	
	QA CLASS: N/A	SCALE: NTS	00063310 SHEET 1 of 1
		SIZE: C	DWG NO: 15B000
			REV: 10