



USER MANUAL  
LIGHT-DRIVE RGB

Please check for the latest updates and changes on the TRAXON website.  
© TRAXON TECHNOLOGIES ALL RIGHTS RESERVED.

**WWW.TRAXONTECHNOLOGIES.COM**

HONG KONG NEW YORK PARIS TOKYO RIO DE JANEIRO FRANKFURT MELBOURNE SHANGHAI BIRMINGHAM ROTTERDAM

Manual - Version 1.0

## USER MANUAL

### INDEX

---

1. INTRODUCTION: P1-2
  2. CONTENTS: P3
  3. INSTALLATION: P4-5
  4. SYSTEM CONFIGURATION: P6-7
  5. FUNCTION: P8-12
  6. DIP-SWITCH SETTINGS: P12-15
  7. IR REMOTE CONTROL: P16
  8. ELECTRONICS: P17
  9. CARE AND MAINTENANCE: P18
  10. WARRANTY STATEMENT: P18
-

# 1. INTRODUCTION

LIGHT DRIVE RGB SC.CD.5000000 (BLACK)  
LIGHT DRIVE RGB SC.CD.5000100 (WHITE)

The wall mount unit is a standalone DMX controller for RGB LED fixtures. The device provides direct access to connected DMX devices enabling control of color and brightness. Memory slots allow color presets. A sequence and i-wash mode offer dynamic scene playback.

The device comes with a sophisticated user interface providing colored keys as well as a jog dial for setting values.

The device is designed as a plug & play unit (no configuration needed).

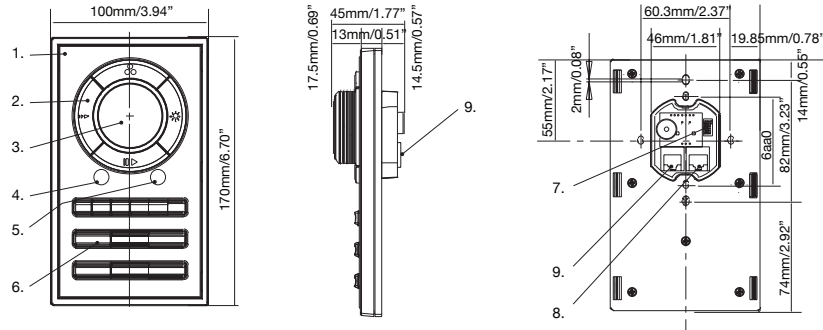

1. Light-Drive cover
2. Function buttons (Color, Brightness, Speed, Play/ Pause)
3. Jog dial / ON-OFF switch
4. Proximity sensor
5. IR sensor
6. Function buttons (Memory slots m1-m6, Zone1, Zone2, ZoneX, Sequence Function, White Mode, iWash Function)
7. DIP switch
8. Output 1
9. Output 2

# 1.1 SAFETY INSTRUCTION

FOR YOUR OWN SAFETY AND THAT OF THE PRODUCT, PLEASE READ THIS USER MANUAL CAREFULLY BEFORE BEGINNING SET-UP AND INSTALLATION!

## ⚠ WARNING

- Unpack and check carefully that there is no transportation damage before using the unit.
- Do not touch any printed circuit board without suitable hand protection.
- The maximum ambient temperature is 40°C.
- In the event of serious operating problems, stop using the unit immediately.
- The switch box installation should be performed carefully.
- Always use spare parts identical to those of the original unit.
- Do not touch any wire during operation as high voltage may cause electric shock.

## ⚠ CAUTION

- Keep the outer case of the fixture clean with a soft cloth.
- Audio/Visual such as television and radio may interfere with the device performance. Keep in mind not to use such devices in close proximity to the unit.
- There are no parts which are intended to be serviced or maintained by the user. Do not attempt any repairs without the assistance of a trained professional. In the event your unit may require service, please contact your nearest dealer.

## 2. CONTENTS

LIGHT-DRIVE RGB (SC.CD.5000000) BLACK LIGHT-DRIVE RGB (SC.CD.5000100) WHITE

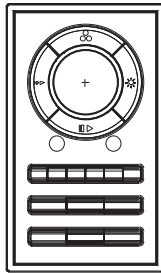

1 X Light-Drive RGB

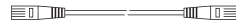

2 X TX Connect Data Cable (DMX)



4 X Mounting Screws

## 3. INSTALLATION

The Light-Drive unit installs easily and quickly with the use of a switch box (optional). The base plate of the Light-Drive has preset mounting holes for international switch box dimensions.

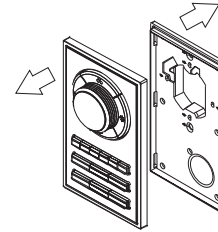

1. Carefully separate the Light-Drive cover and base

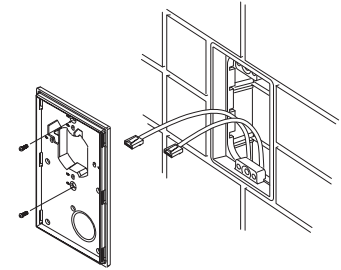

2. Set position of switch box (optional)

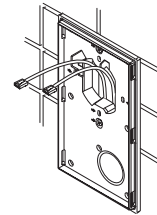

3. Mount Light-Drive base with appropriate screws

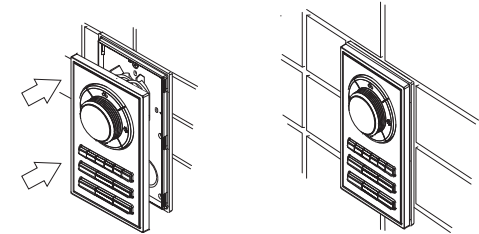

4. Connect output cables and click Light-Drive cover back into place

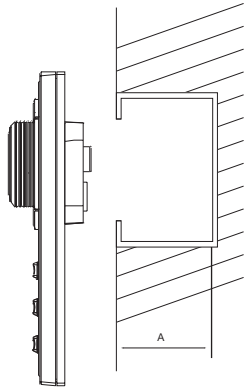

1. Switch box depth (A) must be at least 35mm/1.38" to install. Please check your local switch box size before installation.
2. Light Drive unit supports UK, EU, USA, and JP standard switch box dimensions.
3. The switch box installation should be performed carefully.
4. Be careful to avoid touching the PCB with a bare hand.
5. DO NOT power up the unit until all installation steps are completed.

## 4. SYSTEM CONFIGURATION

### 4-1. TX Connect

TX Connect is an easy and user friendly plug'n'play connection system for TRAXON products.

#### Connection Accessories



**TX CONNECT Smart Data (DMX) Cable**

0.2m	DI.IC.0020000
1m	DI.IC.0100000
3m	DI.IC.0300000
5m	DI.IC.0500000
10m	DI.IC.1000000
20m	DI.IC.2000000

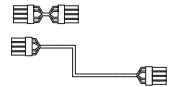

**TX CONNECT Smart Interconnection Cable**

8cm	TI.IC.0008000
30cm	TI.IC.0030000
60cm	TI.IC.0060000



**AC Power Cable, 2m**

EU	PS.AC.0000100
US	PS.AC.0000200
UK	PS.AC.0000300
AU	PS.AC.0000400
JP	PS.AC.0000500



**TX CONNECT Smart Power/Data Injector Box**

TI.ZI.0000100



**TX CONNECT Smart Data Extractor Box**

TI.DO.0000100



**LED Engine Smart 100W Indoor**

PS.IA.0010000

## 4-2. System Diagram

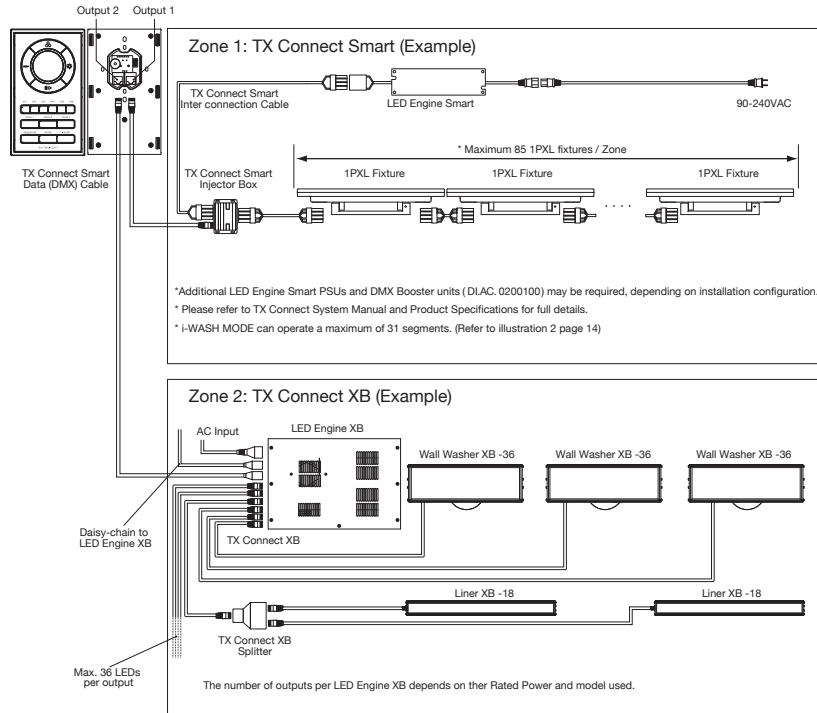

Note: The above shown configurations are examples only. The Light-Drive can be used with any 1PXL RGB lighting fixture (Module, Board, Cove Light, Strip). In the case of applications using XB line fixtures only ( Wall Washer XB, Liner XB, Nano Liner XB, Spot XB) use the new series LED Engine XB ( PX.IC.xxxxxx/PX.ID.xxxxxx ) available Q4, 2008. Please refer to your local Traxon dealer for more details.

DMX address chart of each output (Refer page 1. Output)

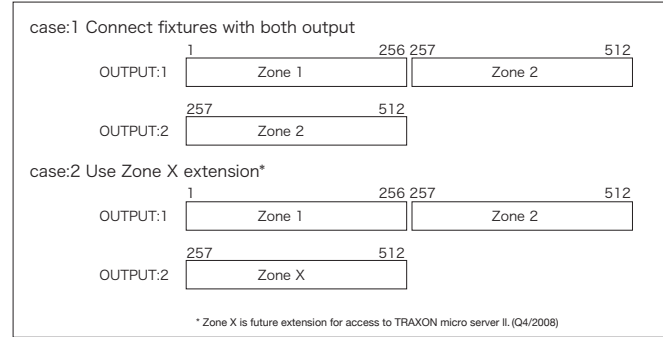

## 5. FUNCTIONS

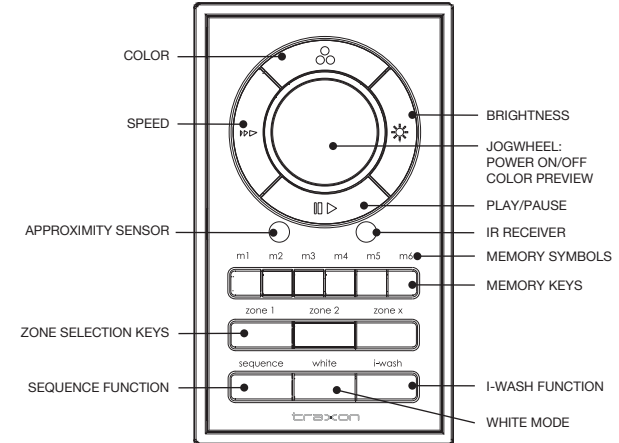

## 5-1. JOG/NAVIGATION

---

- Pushing the Jog-wheel activates/deactivates the unit.
- By default the Jog wheel modifies the BRIGHTNESS of the selected zone. Turning the wheel clockwise, increases the intensity and vice versa. (The Jog-wheel is back lit with RGB LEDs.)
- When the unit is set to BRIGHTNESS MODE, the Jog back light is white. The unit automatically switches to this mode after being idle for 10 seconds.
- Pressing the COLOR button activates COLOR MODE. The Jog-wheel back light synchronizes with current color output of selected zone.
- By turning the Jog-wheel you can select any RGB color.
- The SPEED button is only active during playback in SEQUENCE/i-WASH function.
- During playback in SEQUENCE or i-WASH function, playback can be paused or continued by pressing the PLAY/PAUSE button.
- During all other modes, the unit switches to SEQUENCE function by pressing the PLAY/PAUSE button.
- The LED display of the MEMORY buttons indicate the current speed as a “bar graph”: No LEDs ON - slowest replay speed, all LEDs ON - fastest replay speed.
- All buttons are equipped with LED backlight. These are activated by a proximity sensor. In idle mode, they will automatically turn off after 5 seconds, the Jog-wheel after 10 seconds.

## 5-2 MODES

---

### 5-2.1 MEMORY MODE

Press M1-M6 to save and recall color settings in selected zone (from any other mode, press any memory key for 1 second to go into MEMORY MODE).

- ☀ Brightness:
  - Turn Jog-wheel to increase /decrease brightness.
  - Press Brightness for 2 seconds to set brightness to 100%.
  - Press M1-M6 for 2 seconds to save current color setting to memory (short beep confirms saving).
- Color:
  - Turn jog-wheel to change color.
  - Jog-wheel back light displays output color.
  - Press M1-M6 for 2 seconds to save current color setting to memory (short beep confirms saving).
- ▶▶ Speed:
  - N/A
- ||▶ Play/Pause
  - Unit enters SEQUENCE function

### 5-2.2 SEQUENCE FUNCTION

Press the Sequence button to activate SEQUENCE function in the selected zone.

- ☀ Brightness:
  - Turn Jog-wheel to increase /decrease brightness.
  - Press Brightness for 2 seconds to set brightness to 100%.
- Color:
  - Unit enters COLOR MODE
- ▶▶ Speed:
  - Turn Jog-wheel to increase /decrease speed.
  - Memory symbols show the speed as a “bar graph”
- ||▶ Play/Pause
  - Pauses the current replay (Play/Pause is blinking)

### 5-2.3 WHITE FUNCTION

Press the WHITE button to activate WHITE MODE in the selected zone.

- ☀ Brightness: • Turn Jog-wheel to increase / decrease brightness.
  - Press Brightness for 2 seconds to set brightness to 100%.
- ☘ Color: • Turn Jog-wheel to fade between Warm White and Cold White.
- ▶▶ Speed: • N/A
- ||▶ Play/Pause • Unit enters SEQUENCE function

### 5-2.4 i-WASH FUNCTION

Press the i-Wash button to activate iWash function (soft fade on the outer color circle range [RGB]) in the selected zone. In Zone 1 the device replays the color fade sequentially over several devices (see point.6).

- ☀ Brightness: • Turn Jog-wheel to increase / decrease brightness.
  - Press Brightness for 2 seconds to set brightness to 100%.
- ☘ Color: • Unit enters COLOR MODE
- ▶▶ Speed: • Turn Jog-wheel to increase / decrease speed.
  - Memory symbols show the speed as a “bar graph”
- ||▶ Play/Pause • Pauses the current iWash replay (Play/Pause is blinking)

### 5-2.5 ZONE 1 / ZONE 2 / ZONE X

This unit offers access to three different zones. By pressing the Zone buttons you can access the specified zone. Each Zone button has a LED back-light to mark the currently selected zones.

- Zone 1: • Controls 256 DMX channels on output 1
- Zone 2: • Controls 256 DMX channels on output 2
- Zone X: • This button gives access to an external server via e:bus (Function available Q4/2008, refer to your Traxon Partner for further information.)

### 5-2.6 IDLE MODE

After 10 seconds without interaction, the unit goes into Idle-Mode automatically.

- All LED backlight turn off.
- All active Sequence/i-Wash modes keep running. ( If the Proximity Sensor registers any activity, the unit will automatically enter the last active mode.)

### 5-2.7 SPECIAL FUNCTIONS

Press Zone 1 and Zone 2 button simultaneously and hold for 2 seconds to copy all memory setting (M1-M6) of Zone 1 into Zone 2 (short beep confirms saving).

## 6. DIP-SWITCH SETTINGS

---

### 6-1. DIP OVERVIEW

---

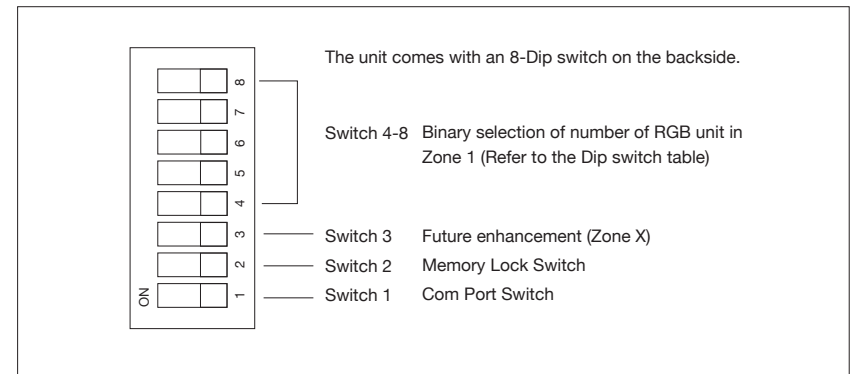



## 6-2. MEMORY LOCK SWITCH

A memory lock switch on the backside of the unit disables any user change of memory slot presets.

## 6-3. SETTING NUMBER OF DEVICES IN ZONE 1

The DIP switch settings allows you to set the number of fixtures/light segments for the dynamic iWash function in Zone 1 (See table below).

The Light-Drive will address the first 31 sets of RGB channels (93 DMX channels), i.e. if all fixtures are set to Auto-Addressing ON, the iWash function will be displayed on the first 31 fixtures only (Illustration 1). In order to set the light segments for the iWash function, please set the fixtures that are to follow one segment to Auto-Addressing OFF (Illustration 2).

Illustration 1

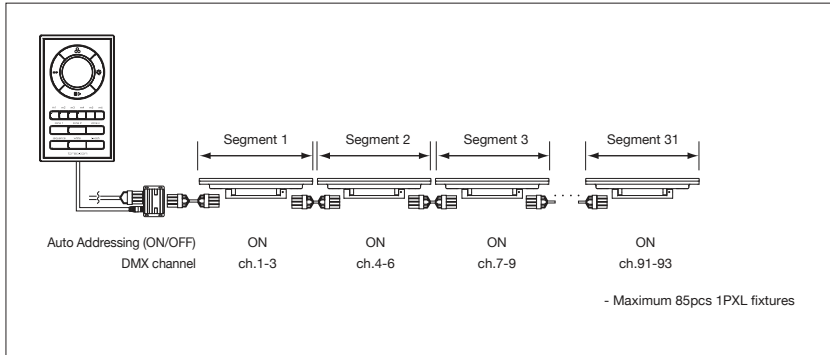
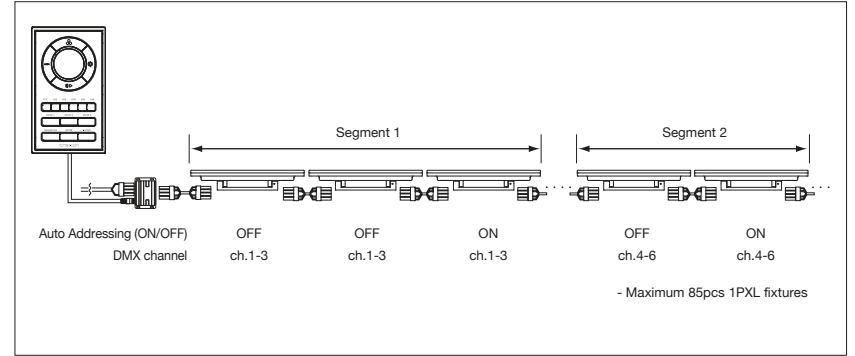

Illustration 2



# Fixtures / Light Segments	DIPSWITCH				
	4	5	6	7	8
All	0	0	0	0	0
1	1	0	0	0	0
2	0	1	0	0	0
3	1	1	0	0	0
4	0	0	1	0	0
5	1	0	1	0	0
6	0	1	1	0	0
7	1	1	1	0	0
8	0	0	0	1	0
9	1	0	0	1	0
10	0	1	0	1	0
11	1	1	0	1	0
12	0	0	1	1	0
13	1	0	1	1	0
14	0	1	1	1	0

# Fixtures / Light Segments	DIPSWITCH				
	4	5	6	7	8
15	1	1	1	1	0
16	0	0	0	0	1
17	1	0	0	0	1
18	0	1	0	0	1
19	1	1	0	0	1
20	0	0	1	0	1
21	1	0	1	0	1
22	0	1	1	0	1
23	1	1	1	0	1
24	0	0	0	1	1
25	1	0	0	1	1
26	0	1	0	1	1
27	1	1	0	1	1
28	0	0	1	1	1
29	1	0	1	1	1
30	0	1	1	1	1
31	1	1	1	1	1

## 7. IR REMOTE CONTROL (SC.AC.0100100)

The IR Sensor is able to receive IR signals from the dedicated Light-Drive Infrared Controller. The remote control activates and recalls all functions on the Light-Drive. (Except storing color settings on m1-m6 and zone1 to zone 2 copying.)

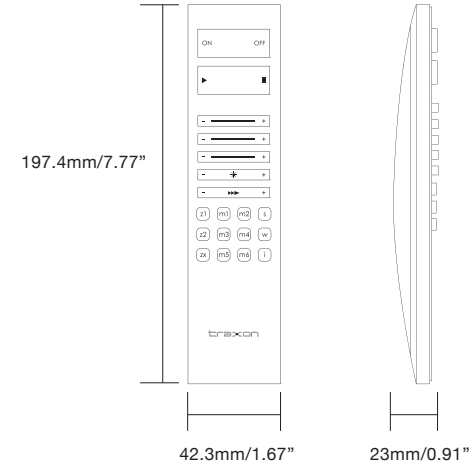

## 8. ELECTRONICS

### 8-1. PIN ASSIGNMENT OF OUTPUT CONNECTORS

The PIN assignment of the two DMX outputs (female RJ45 ports) is as follows:

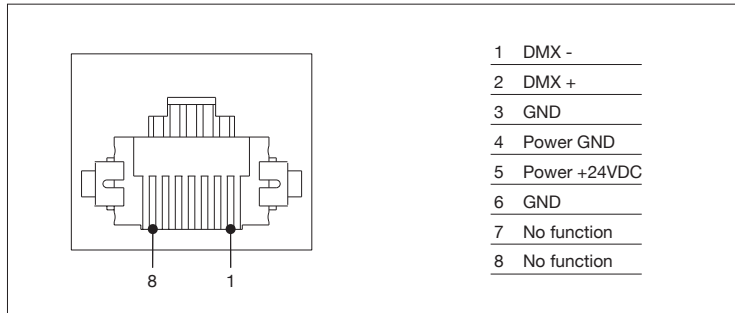

### 8-2. POWER SUPPLY

The unit is powered by an external PSU running at 24 VDC. Power is only supplied via RJ45 pins. Both RJ45 Plugs provide blocking diodes against cross-current of different levels.

### 8-3. TECHNICAL SPECIFICATIONS

Dimension:	100mm x 170mm x 45mm / 3.93" x 6.69" x 1.77"
Weight:	120g / 0.26lbs
Operating Voltage:	24VDC
Current Consumption:	60mA
Power Consumption:	1.5 Watt
Remote controllable:	Yes
Operating Temperature:	0 °C ~ +50 °C (+32 °F ~ +122 °F)
Environment:	Indoor



## 9. CARE AND MAINTENANCE

Traxon™ products are of superior design and quality and should be treated with care. The recommendations below will help fulfill warranty obligations and gain maintain a quality product.

- Make sure that the power is switched off before installation and/or maintenance
- Make sure that the products are installed correctly and securely
- For indoor use only
- Keep products in a dry and precipitation free area as this may damage the products' electronics.
- Keep products in a dirt and dust free environment
- Make sure the products are not exposed to extreme heat and that they have sufficient airflow and cool air circulation if required
- Do not attempt to service or repair the products unless done by an authorized service personnel. Contact the local Traxon office or distributor for details
- Do not drop, knock or shake the products as rough handling may damage the electronics and void the warranty
- Do not use harsh chemicals, cleaning solvents or strong detergents to clean. Wipe with a damp cloth on housings and a dry cloth on electronics to remove dirt or dust.

If the products are not working correctly, please contact your nearest authorized service centre or Traxon office for assistance.

## 10. WARRANTY STATEMENT

Traxon warrants its Products against material or workmanship defects for a period of two (2) years from date of purchase, provided that the purchased items are used under the conditions stated in this user manuals.

Please refer to the Product Warranty section under [www.traxontechnologies.com/terms](http://www.traxontechnologies.com/terms) for warranty terms and conditions.