

BUYER'S MODEL NO. 14J334

FACTORY MODEL CA05561

ORIGINAL ISSUE March, 1999

SECTION —

REFER TO IMPORTANT NOTICE BELOW

PARTS LIST FOR SERGER MODEL 14J334

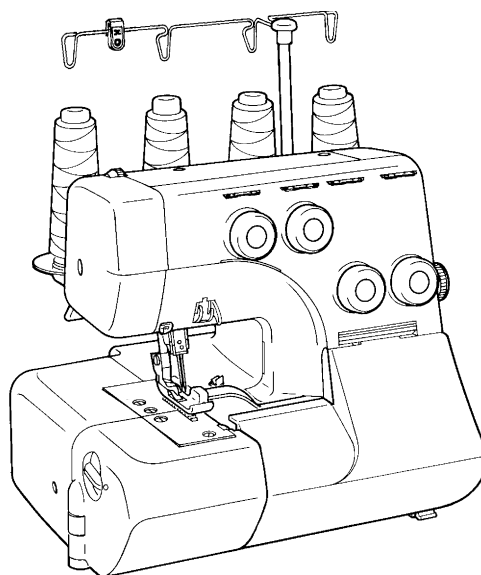

IMPORTANT:

WHEN ORDERING THE PARTS ALWAYS CHECK THE SERIAL NUMBER OF THE MACHINE.

FIRST DIGIT OF THE SERIAL NUMBER MUST MATCH WITH THE LAST DIGIT OF THE FACTORY MODEL ABOVE.

SINGER	
FACTORY MODEL 14J334	SERIAL-NO. DE SÉRIE 1 × × × × × ×
 LISTED 646S US E61486 SEWING MACHINE	120V 1.3A 60Hz MADE IN CHINA FABRIQUE EN CHINE

FIRST DIGIT

SINGER

BUYER'S MODEL NO.	14J334	SECTION	PAGE	REVISION	REMARKS	PART NO.	DESCRIPTION
BUYER'S MODEL NAME		—	1			43389	THRUST WASHER
FACTORY MODEL	CA05561					44066	SPRING PIN
ORIGINAL ISSUE	March, 1999	SERIAL NO.				47181	M4 PHILIPS SCREW
						57746	TAPPING SCREW
						66474	M5 SCREW
						66725	M4 SCREW
						67447	M5 SCREW
						68922	WASHER
						72271	BALL JOINT
						72376	BALANCE CAM
						72622	CRANK ROD
						72623	ECCENTRIC CAM
						72629	SLIDE BLOCK
						72631	ECCENTRIC CAM
						72634	CRANK ROD
						72635	ECCENTRIC CAM
						72636	CONNECTING ROD END
						72637	ECCENTRIC CAM
						72638	ECCENTRIC CAM
						72641	LOOPER DRIVING ARM
						72667	BELT PULLEY
						72679	NYLON WASHER
						72780	MAIN SHAFT
						72788	M4 STUD SCREW
						72806	M5 SCREW
						72858	WASHER
						73472	COLLAR
						77042	M4 PHILIPS SCREW
						79021	HAND WHEEL

BUYER'S MODEL NO.	14J334	SECTION	PAGE	REVISION	REMARKS	PART NO.	DESCRIPTION
BUYER'S MODEL NAME		—	2			8400	E5 CLIP-ON-WASHER
FACTORY MODEL	CA05561					32316	WASHER
ORIGINAL ISSUE	March, 1999	SERIAL NO.				64179	SPRING PIN
						66620	COLLAR
						66725	M4 SCREW
						67447	M5 SCREW
						72271	BALL JOINT
						72341	THRUST WASHER
						72379	ECCENTRIC CAM
						72603	FEED ARM
						72624	FEED BASE
						72625	D.F. FEED BASE
						72626	FEED REGULATING ARM
						72632	FEED REGULATING BLOCK
						72633	SLIDE BLOCK
						72734	WASHER
						72781	SHAFT
						72792	PIN
						72798	PIN
						72802	SHAFT
						72803	SHAFT
						72813	M3.5 SCREW
						72825	TORSION SPRING
						77015	REAR FEED DOG
						77016	FRONT FEED DOG
						77039	SLIDE BLOCK
						77042	M4 PHILIPS SCREW

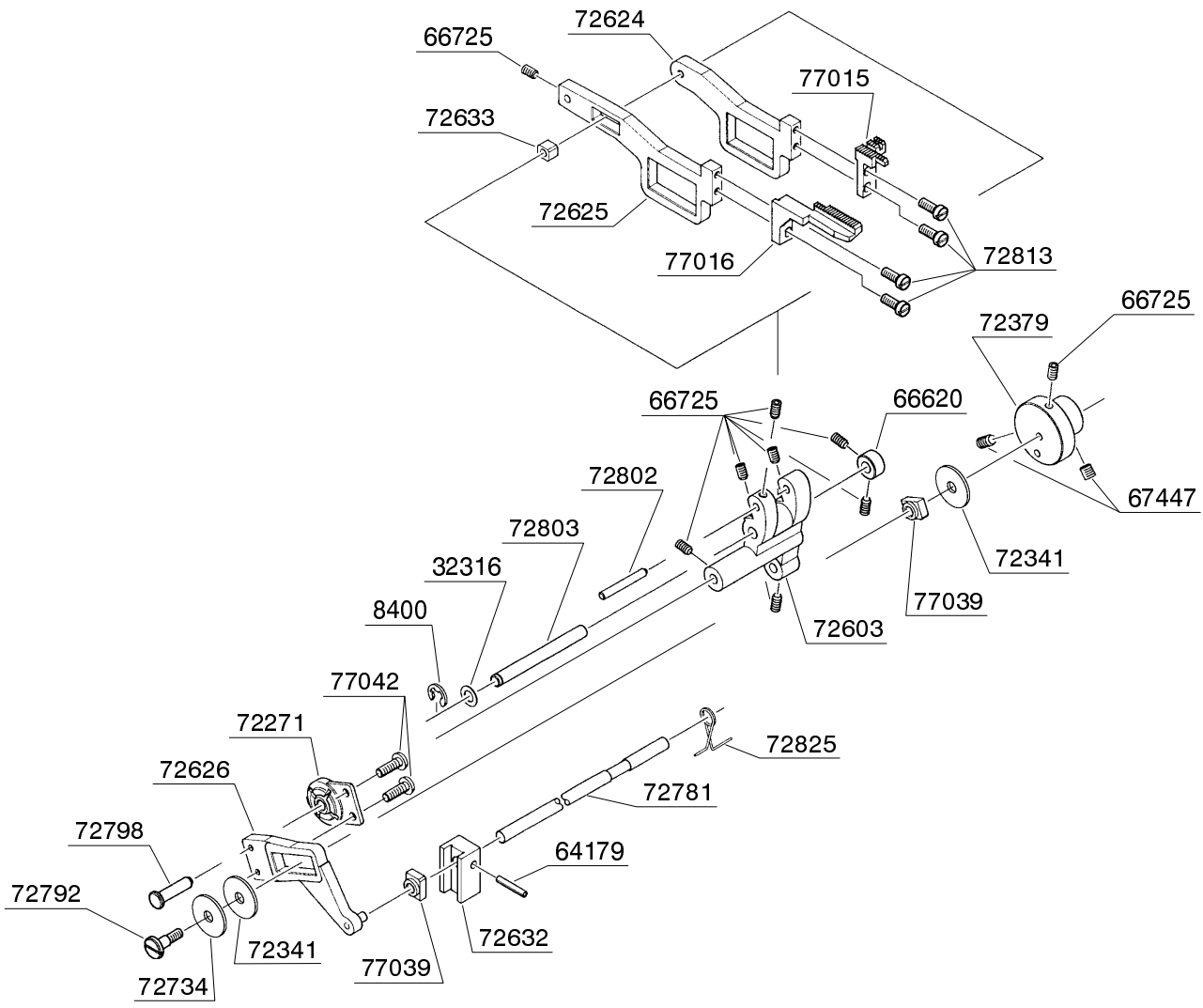

BUYER'S MODEL NO.	14J334	SECTION		PAGE	3	REVISION		REMARKS		PART NO.	DESCRIPTION
BUYER'S MODEL NAME										1513	E4 CLIP-ON-WASHER
FACTORY MODEL	CA05561									2206	WASHER
ORIGINAL ISSUE	March, 1999	SERIAL NO.								24133	PIPE KNOCK PIN
										37910	CLIP-ON-WASHER
										43390	THRUST WASHER
										44044	STUD
										61221	M4 PHILIPS SCREW
										64204	M4 PHILIPS SCREW
										66437	BUSH
										66474	M5 SCREW
										66725	M4 SCREW
										67440	CRANK-ROD ARM
										67444	COLLAR
										67447	M5 SCREW
										67455	HOLDER
										67847	#7 SCREW
										72270	NEEDLE CLAMP
										72274	M3 SCREW
										72287	NEEDLE BAR CRANK
										72337	THREAD GUIDE
										72596	NEEDLE
										72612	MAIN SHAFT ARM LEVER
										72750	THREAD GUIDE
										72751	OSCILLATING LEVER
										72752	CONNECTING ARM
72776	THREAD GUIDE										
72777	NEEDLE BAR										
72779	UPPER SHAFT										
72796	PIN										
72797	CENTER PIN										
72855	THREADER POSITIONER										

BUYER'S MODEL NO.	14J334	SECTION	—	PAGE	4	REVISION		REMARKS		PART NO.	DESCRIPTION
BUYER'S MODEL NAME										1513	E4 CLIP-ON-WASHER
FACTORY MODEL	CA05561									8400	E5 CLIP-ON-WASHER
ORIGINAL ISSUE	March, 1999	SERIAL NO.								32316	WASHER
										58220	WASHER
										61221	M4 PHILIPS SCREW
										62215	M4 NUT
										63278	PRESSER BAR
										72326	WASHER
										72643	PRESSER BAR GUIDE BLOCK
										72717	BRACKET
										72720	BRACKET
										72725	GUIDE PLATE
										72727	GUIDE PLATE
										72728	TENSION RELEASE LEVER
										72766	LIFTER
										72807	M4 STUD SCREW
										72829	COMPRESSION SPRING
										72848	#4 STUD SCREW
										72849	#7 PHILIPS SCREW
										74595	M5 SCREW
										77006	PRESSER FOOT
										77017	PRESSER FOOT HOLDER
										77042	M4 PHILIPS SCREW
										79024	PRESSER CONTROL KNOB
										79025	PRESSER FOOT LIFTING LEVER

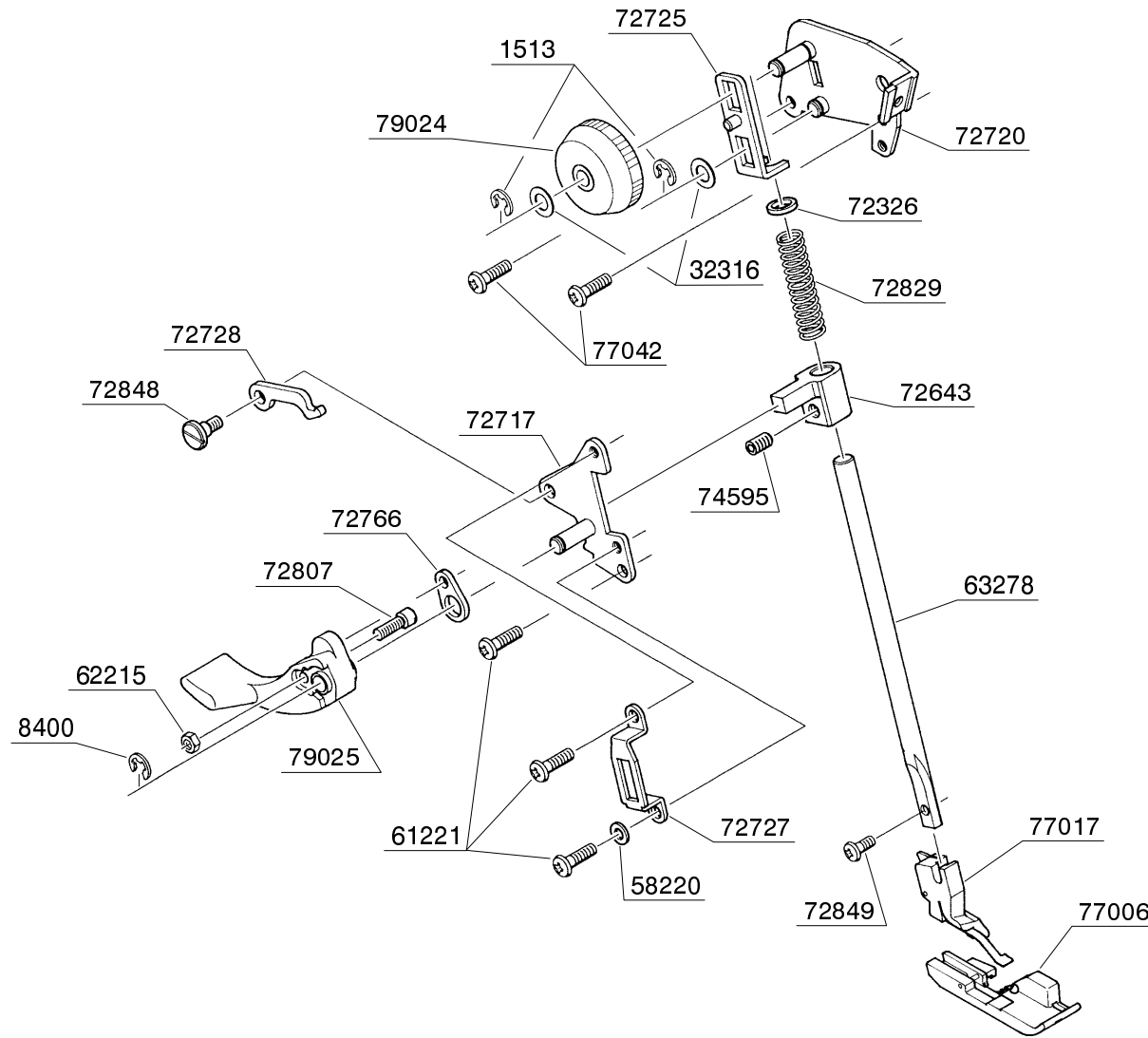

BUYER'S MODEL NO.	14J334	SECTION	—	PAGE	5	REVISION		REMARKS		PART NO.	DESCRIPTION
BUYER'S MODEL NAME										1513	E4 CLIP-ON-WASHER
FACTORY MODEL	CA05561									61222	M4 PHILIPS SCREW
ORIGINAL ISSUE	March, 1999	SERIAL NO.								66620	COLLAR
										66725	M4 SCREW
										67617	WASHER
										72714	STITCH LENGTH CONTROL CAM
										72729	STITCH LENGTH CONTROL ARM
										72730	CONNECTING PLATE
										72737	LEAF SPRING
										72785	SHAFT
										72882	STOPPER
										72885	STOPPER
										77042	M4 PHILIPS SCREW
										79056	STITCH LENGTH CONTROL DIAL

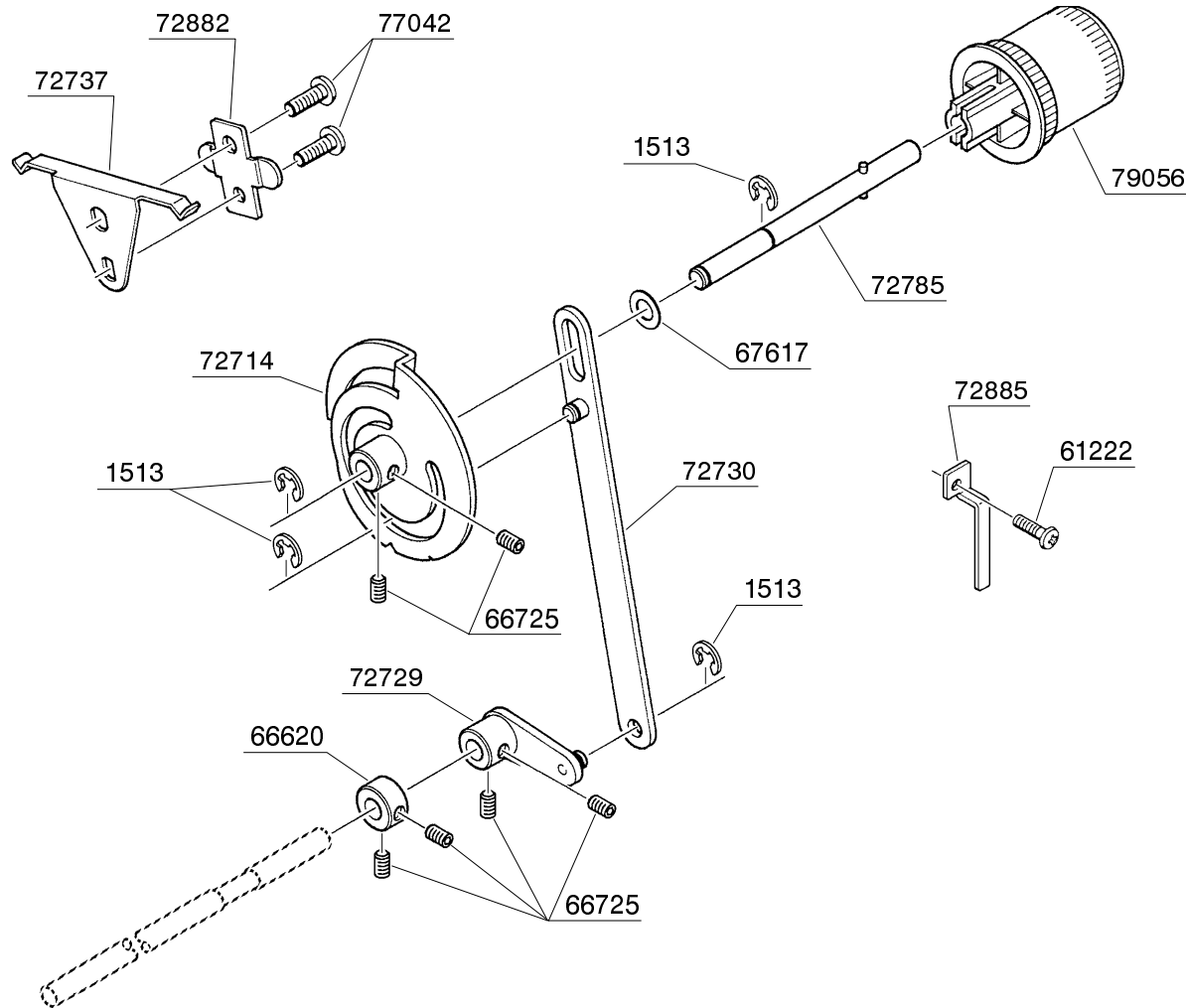

BUYER'S MODEL NO.	14J334	SECTION	PAGE	REVISION	REMARKS	PART NO.	DESCRIPTION
BUYER'S MODEL NAME		—	6			1513	E4 CLIP-ON-WASHER
FACTORY MODEL	CA05561						1520
ORIGINAL ISSUE	March, 1999	SERIAL NO.				2206	WASHER
						46293	CLIP-ON-WASHER
						62215	M4 NUT
						66352	M4 PHILIPS SCREW
						66437	BUSH
						66620	COLLAR
						66725	M4 SCREW
						72627	FEED CONTROL LOCKING ARM
						72628	D.F. LINK
						72633	SLIDE BLOCK
						72644	SLIDE BLOCK
						72683	D.F. ARM
						72686	CONNECTING ROD
						72731	D.F. ARM (A)
						72733	D.F. ARM (C)
						72735	D.F. ARM (D)
						72736	CONNECTING PLATE
						72786	SHAFT
						72799	PIN
						72800	PIN
						72801	SHAFT
						72804	PIN
						72805	SHAFT
72835	HOOK FOR SPRING						
72836	EXTENSION SPRING						
72837	TORSION SPRING						
79031	D.F. DIAL						

BUYER'S MODEL NO.	14J334	SECTION	PAGE	REVISION	REMARKS	PART NO.	DESCRIPTION
BUYER'S MODEL NAME		—	7			1615	WASHER
FACTORY MODEL	CA05561					2744	WASHER
ORIGINAL ISSUE	March, 1999	SERIAL NO.				4844	WASHER
						8400	E5 CLIP-ON-WASHER
						10963	E6 CLIP-ON-WASHER
						61224	M4 PHILIPS SCREW
						62309	M3 SCREW
						63173	PIN
						63501	WASHER
						64653	M3 SCREW
						66725	M4 SCREW
						67445	COLLAR
						67447	M5 SCREW
						72160	STUD
						72165	KNIFE RELEASE KNOB
						72168	COLLAR
						72169	KNOB MOUNTING BRACKET
						72171	LINK (B)
						72180	STUD
						72183	M3.5 BOLT
						72187	COMPRESSION SPRING
						72191	STUD
						72207	COMPRESSION SPRING
						72258	DRIVING ARM
						72261	SHAFT
						72296	COMPRESSION SPRING
						72392	SPRING PLATE
						72645	LINK
						72646	POSITIONER
						72704	LOWER KNIFE HOLDER
72744	NEEDLE PLATE HOLDER						
72745	LEAF SPRING						
72759	LEVER						
72791	M4 SCREW						
72815	SHAFT						
72817	SHAFT						
72819	HEXAGONAL PIN						
72838	STUD						
77005	LOWER KNIFE						
77042	M4 PHILIPS SCREW						
77044	M3 PHILIPS SCREW						
77053	M3 PHILIPS SCREW						
77073	UPPER KNIFE						
79026	CONTROL KNOB						
79029	LOWER KNIFE COVER						

BUYER'S MODEL NO.	14J334	SECTION		PAGE	8	REVISION		REMARKS		PART NO.	DESCRIPTION
BUYER'S MODEL NAME		—	8						10963	E6 CLIP-ON-WASHER	
FACTORY MODEL	CA05561								63163	KNIFE LEVER ASSEMBLY	
ORIGINAL ISSUE	March, 1999								63171	FIXING BASE	
		SERIAL NO.							63264	M5 BOLT WITH WASHER	
										66725	M4 SCREW
										67445	COLLAR
										72746	NEEDLE PLATE HOLDER
										72748	NEEDLE RECEIVER (B)
										72791	M4 SCREW
										72812	SHAFT
										72899	NEEDLE PLATE
										77042	M4 PHILIPS SCREW
										77056	WASHER

BUYER'S MODEL NO.	14J334	SECTION	PAGE	REVISION	REMARKS	PART NO.	DESCRIPTION
BUYER'S MODEL NAME		—	9			10963	E6 CLIP-ON-WASHER
FACTORY MODEL	CA05561						35942
ORIGINAL ISSUE	March, 1999	SERIAL NO.				43393	WASHER
						61222	M4 PHILIPS SCREW
						61588	WASHER
						62309	M3 SCREW
						63805	WASHER
						64359	M4 SCREW
						65818	M4 BOLT
						66725	M4 SCREW
						67251	M3.5 PHILIPS SCREW
						67444	COLLAR
						72135	THREAD GUIDE (B)
						72639	LOOPER BASE
						72640	UPPER LOOPER SUPPORTING ARM
						72642	PIVOT
						72747	NEEDLE RECEIVER (A)
						72767	BED COVER
						72768	LOOPER COVER
						72775	THREAD GUIDE (A)
						72787	PIN
						72793	LOOPER SLIDE SHAFT
						72794	SHAFT
						72795	SHAFT
						72818	PIN
						72821	COLLAR
						72827	THREAD GUIDE
						73900	M3 PHILIPS SCREW
						73973	M4 BOLT
						77013	UPPER LOOPER
						77014	LOWER LOOPER

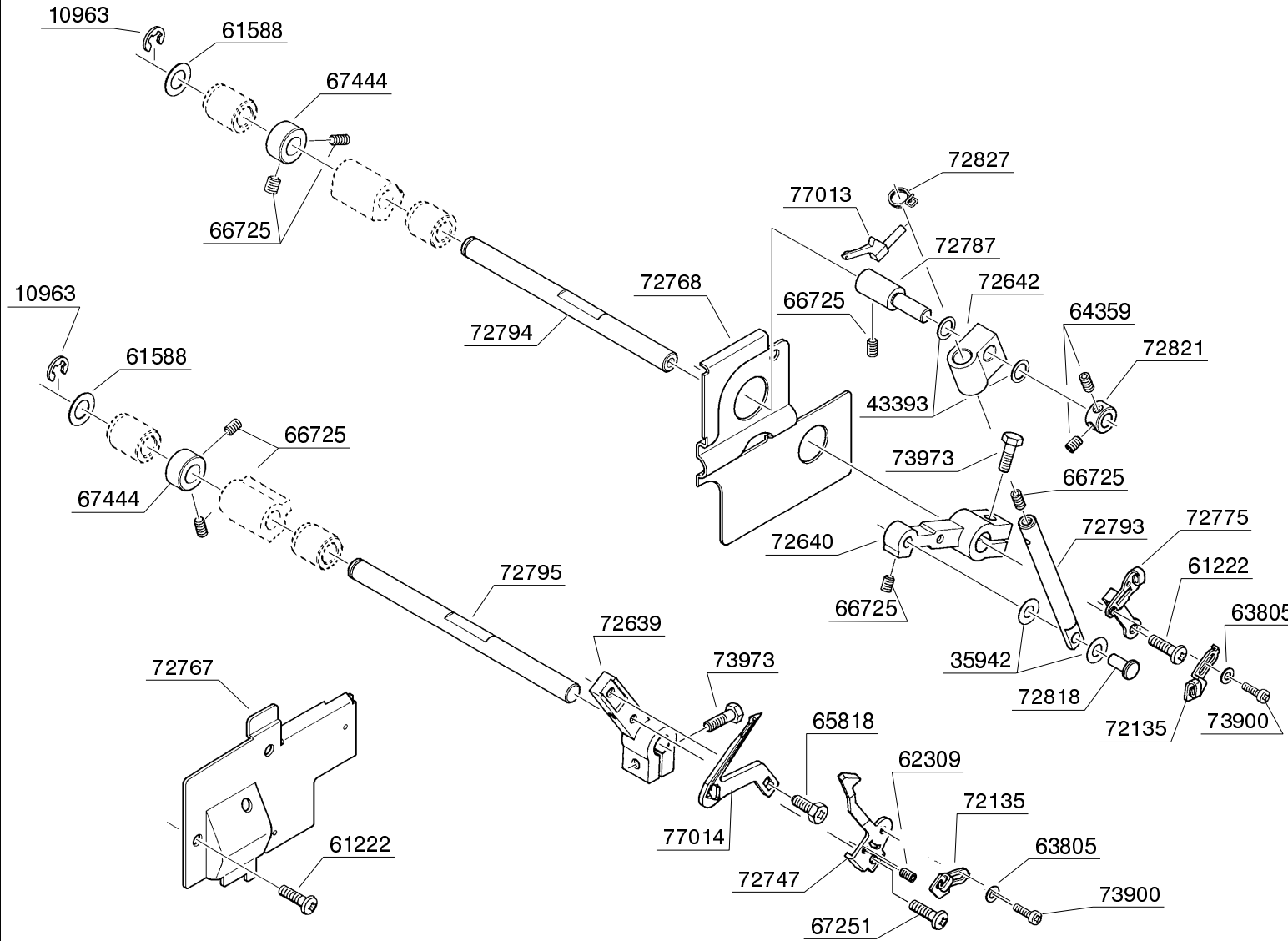

BUYER'S MODEL NO.	14J334	SECTION	PAGE	REVISION	REMARKS	PART NO.	DESCRIPTION
BUYER'S MODEL NAME		—	10			40110	TERMINAL BLOCK
FACTORY MODEL	CA05561			40111	TERMINAL BLOCK COVER		
ORIGINAL ISSUE	March, 1999	SERIAL NO.				41892	TERMINAL BLOCK COVER
						42269	WASHER
						44498	M3 NUT
						59181	SWITCH ASSEMBLY
						61221	M4 PHILIPS SCREW
						61224	M4 PHILIPS SCREW
						62307	M4 SCREW
						66311	M5 BOLT WITH WASHER
						66941	MOTOR PULLEY
						67701	TIMING BELT
						68891	WASHER
						72385	REFLECTION PLATE
						72649	TERMINAL CASE
						72740	VINYL TUBE
						72760	TERMINAL BRACKET
						72765	SWITCH BRACKET
						72773	CORD GUIDE
						72936	LIGHT BULB
						72938	HARNESS
						72940	MOTOR BRACKET
						72950	MOTOR
						77042	M4 PHILIPS SCREW
						77057	M3 PHILIPS SCREW
						77078	CORD GUARD

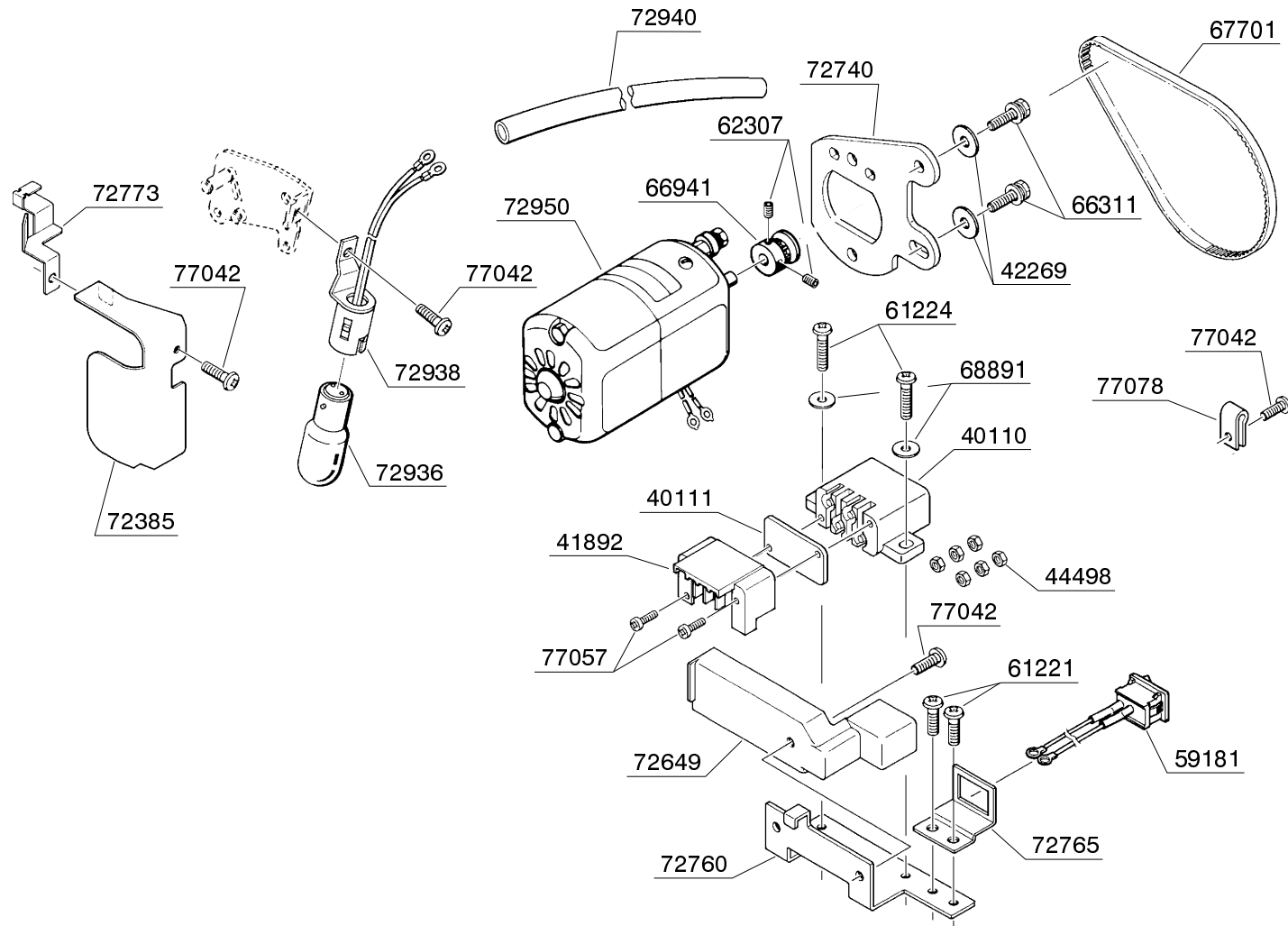

BUYER'S MODEL NO.	14J334	SECTION		PAGE	11	REVISION		REMARKS		PART NO.	DESCRIPTION
BUYER'S MODEL NAME										10963	E6 CLIP-ON-WASHER
FACTORY MODEL	CA05561									44125	SPOOL PIN
ORIGINAL ISSUE	March, 1999	SERIAL NO.								61225	M4 PHILIPS SCREW
										61588	WASHER
										68891	WASHER
										72288	THREAD
										72289	THREAD
										72709	LOVER PLATE
										72713	BRACKET
										72764	LEAF SPRING
										72791	M4 SCREW
										72820	EXTENSION BAR
										72884	DETACHABLE INSERT PLATE
										77042	M4 PHILIPS SCREW
										79000	DETACHABLE CORD GUIDE
										79011	BED COVER
										79018	THREAD GUIDE
										79019	GUIDE PLATE
										79027	HOLDER
										79039	M4 PHILIPS SCREW
										79044	FACE COVER
										79046	SHUTTER
										79051	TOP COVER
										79053	SIDE COVER
										79070	SPOOL PIN CAP

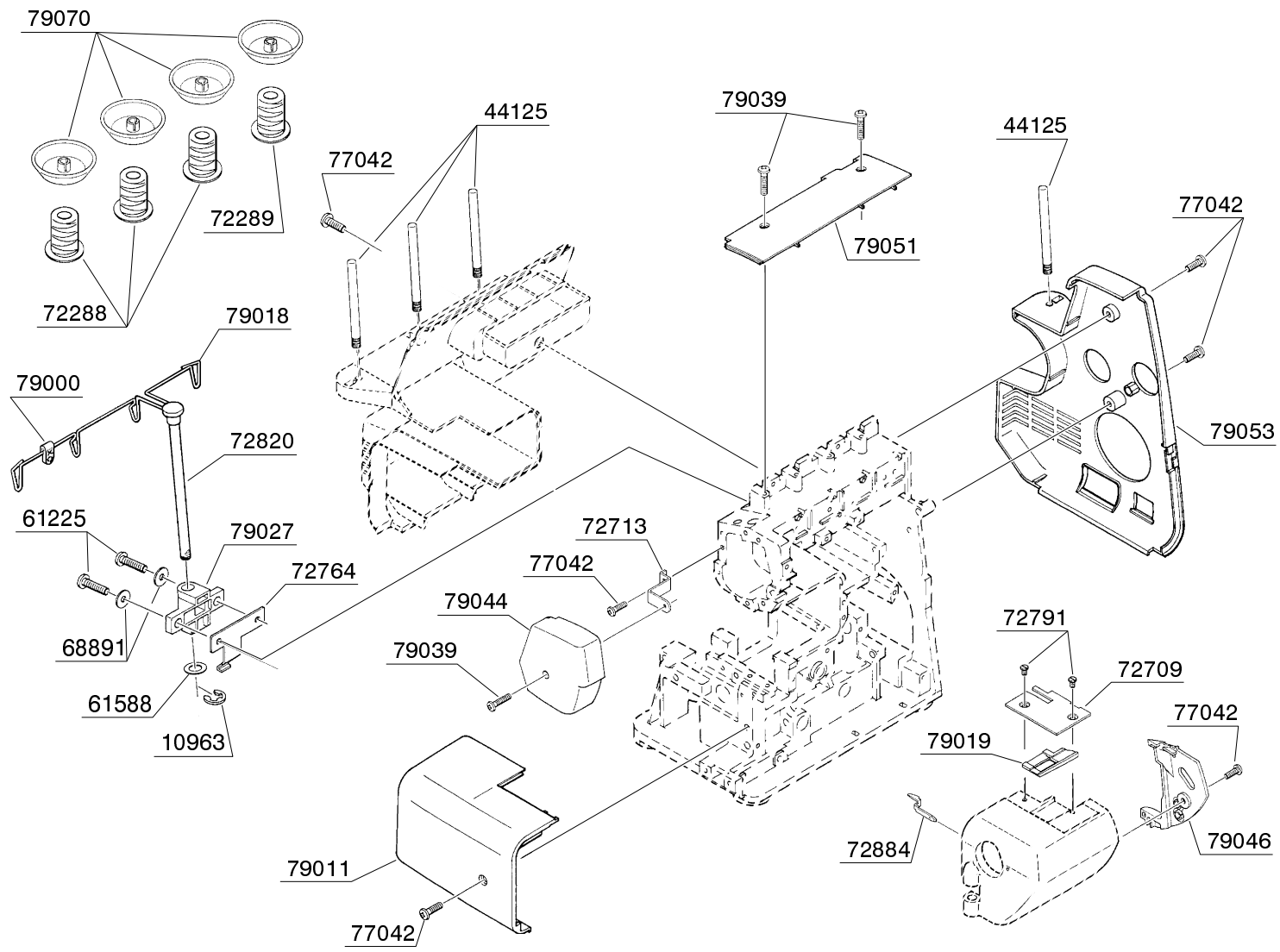

BUYER'S MODEL NO.	14J334	SECTION	—	PAGE	12-1	REVISION	August, 2000	REMARKS		PART NO.	DESCRIPTION	
BUYER'S MODEL NAME										58024	TAPPING SCREW	
FACTORY MODEL	CA05561									61225	M4 PHILIPS SCREW	
ORIGINAL ISSUE	March, 1999	SERIAL NO.								64618	TAPPING SCREW	
										72395	THREAD GUIDE	
											72757	THREAD GUIDE (A)
											72840	SPONGE
											72842	THREADING SHEET
											72871	MOUNTING BRACKET
											72875	THREAD GUIDE PLATE
											72879	THREAD GUIDE
											72891	THREAD GUIDE
											77042	M4 PHILIPS SCREW

BUYER'S MODEL NO.	14J334	SECTION	—	PAGE	12-2	REVISION	August, 2000	REMARKS		PART NO.	DESCRIPTION
BUYER'S MODEL NAME										8400	E5 CLIP-ON-WASHER
FACTORY MODEL	CA05561									39160	TAPPING SCREW
ORIGINAL ISSUE	March, 1999	SERIAL NO.								50977	D.T. DIAL ASSEMBLY
										50978	D.T. DIAL ASSEMBLY
										50979	D.T. DIAL ASSEMBLY
										50980	D.T. DIAL ASSEMBLY
										55599	SPRING PIN
										72344	SHAFT
										72347	PRESSER DISC RECEIVER
										72348	COMPRESSION SPRING
										72349	COMPRESSION SPRING
										72350	TOOTHED WASHER
										72351	TORSION SPRING
										72369	D.T. GUIDE PLATE
										72726	DIAL TENSION DISC (B)
										72749	DIAL TENSION DISC (A)
										72761	PRESSER DISC
										72830	COMPRESSION SPRING
										72831	COMPRESSION SPRING
										72892	BUSHING
										79002	D.T. DIAL

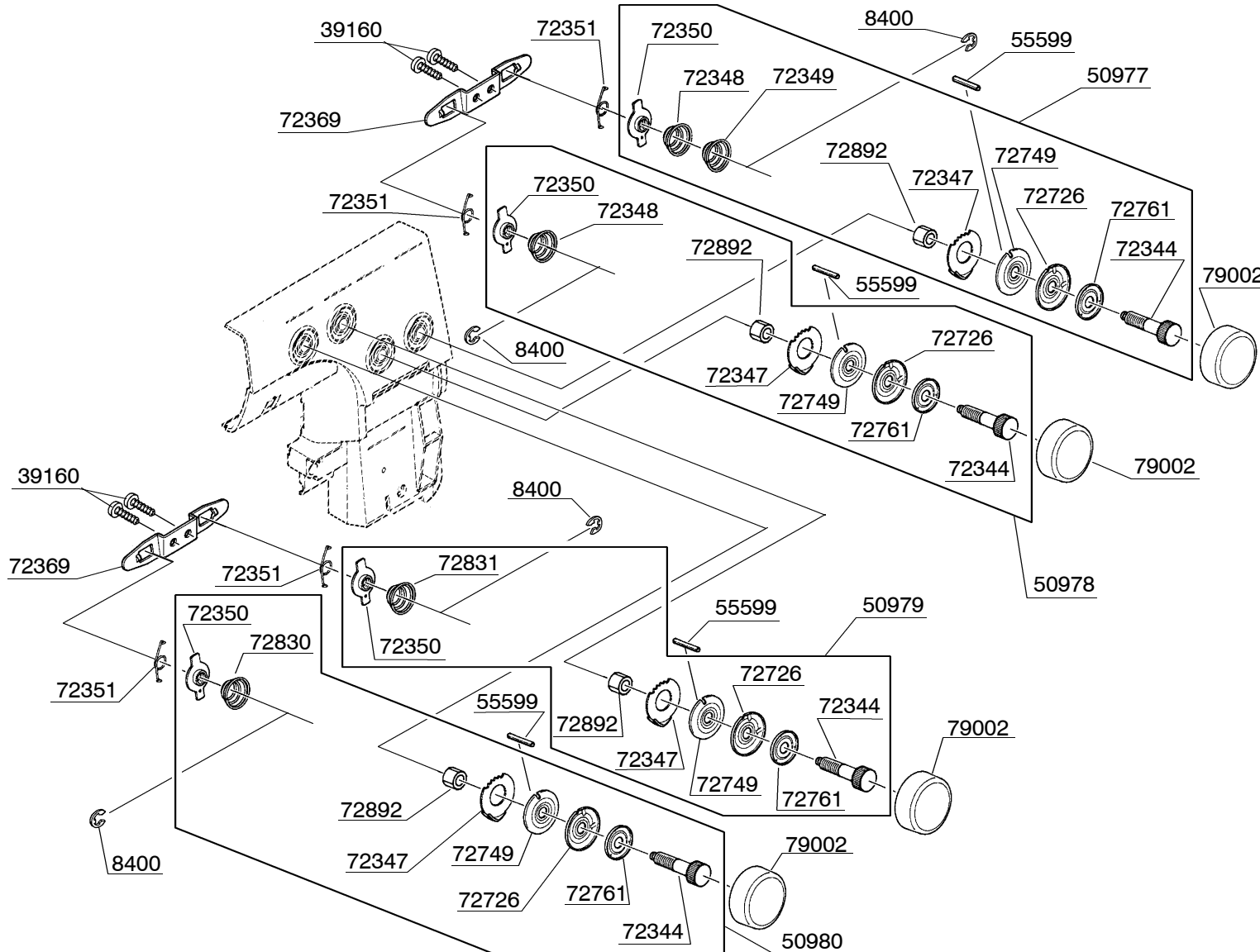

BUYER'S MODEL NO.	14J334	SECTION	PAGE	REVISION	REMARKS	PART NO.	DESCRIPTION
BUYER'S MODEL NAME		—	13			1520	E3 CLIP-ON-WASHER
FACTORY MODEL	CA05561						39160
ORIGINAL ISSUE	March, 1999	SERIAL NO.				61224	M4 PHILIPS SCREW
						62016	TAPPING SCREW
						68891	WASHER
						72598	RUBBER CUSHION
						72662	BASE
						72681	COMPRESSION SPRING
						72753	HINGED BRACKET (A)
						72754	HINGED BRACKET (B)
						72808	SHAFT
						72841	SPONGE HOLDER
						77042	M4 PHILIPS SCREW
						79045	FRONT COVER
						79047	LINT BOX
						79052	INNER ATTACHMENT CASE

BUYER'S MODEL NO.	14J334	SECTION	PAGE	REVISION	REMARKS	PART NO.	DESCRIPTION
BUYER'S MODEL NAME		—	14			45773	CUSHION HOLDER
FACTORY MODEL	CA05561						50949
ORIGINAL ISSUE	March, 1999	SERIAL NO.				59455	EXTENSION PLATE
						63398	SEWING MACHINE OIL
						63523	NET
						65650	CLEANING BRUSH
						69949	BOOK(ENG.,SPA.)
						72391	STITCH FINGER
						72534	DUST COVER
						72597	NEEDLE SET
						72828	TWEEZERS
						72847	ACCESSORY VINYL BAG
						72917	FOOT CONTROL
						74793	SMALL SCREW DRIVER

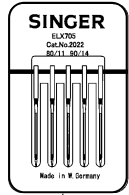

72597

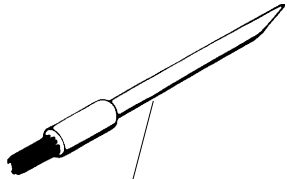

65650

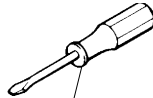

74793



63398

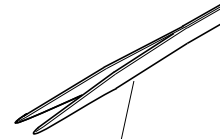

72828

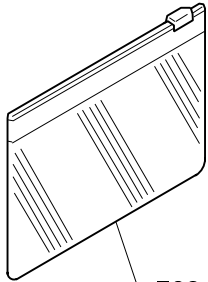

72847



63523

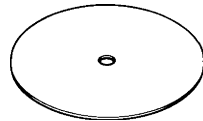

59455



45773

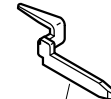

72391

50949

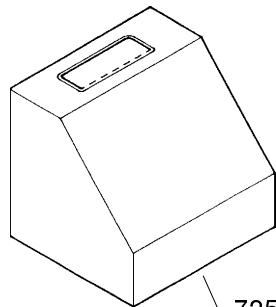

72534

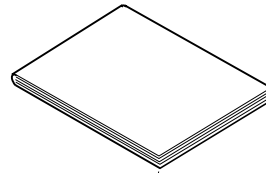

69949

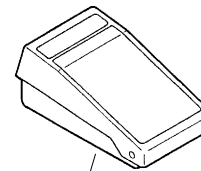

72917