

# CS\* CHICKEN SWITCH®

A Portable Actuator for Remotely  
Operating the Trip/Close Lever on  
Square D BoltLocSwitches



## BL-30 Model User's Manual

# CS\* CHICKEN SWITCH®

## *User's Manual* *Model BL-30* *For use on Square D* *BoltLoc Switch Trip Handles*

- 1.0 Arc-blast Hazards
- 2.0 Safety Information
  - 2.1 Finger pinch points
  - 2.2 Strong magnets
  - 2.3 Battery precautions
  - 2.4 Charger precautions
- 3.0 Battery Information
  - 3.0 Battery Requirements
  - 3.1 Battery Life
  - 3.2 Battery Replacement
- 4.0 Operation
  - 4.1 Connecting the control cable
  - 4.2 Sequence of operation
  - 4.3 Attaching and removing the actuator
  - 4.4 Indicator lights
- 5.0 Care and Storage
  - 5.1 Cleaning debris from magnets
  - 5.2 Storage
- 6.0 Warranty
- 7.0 Specifications

## 1.0 Arc-blast Hazards

The hazards associated with electrical arc-blasts are well documented. Studies conducted by numerous industries and professional organizations have sought to quantify the intensity of arc-blast, the risks to personnel, and various methodologies for mitigating the risks.

Without doubt, increasing the distance between the arc and a human is the single greatest favorable factor in reducing injuries.

The Chicken Switch® is not a panacea but rather one more tool available for protecting workers while they are performing electrical switching.

Using a Chicken Switch® may not negate the need for additional personal protective measures. The user is ultimately responsible for evaluating each situation to determine if additional protective measures are needed.



### WARNING

**Electrical switching may present risk of serious injury or death. This device should only be used by qualified persons after careful analysis of the hazards.**

## 2.0 Safety Information

ALWAYS connect the control cable to the actuator BEFORE installing the Chicken Switch®.

### 2.1 Finger pinch points

NEVER place your fingers below the red gearbox enclosure when the control station is connected to the actuator. The actuator arm/rollers could pinch your hand/fingers against the frame.

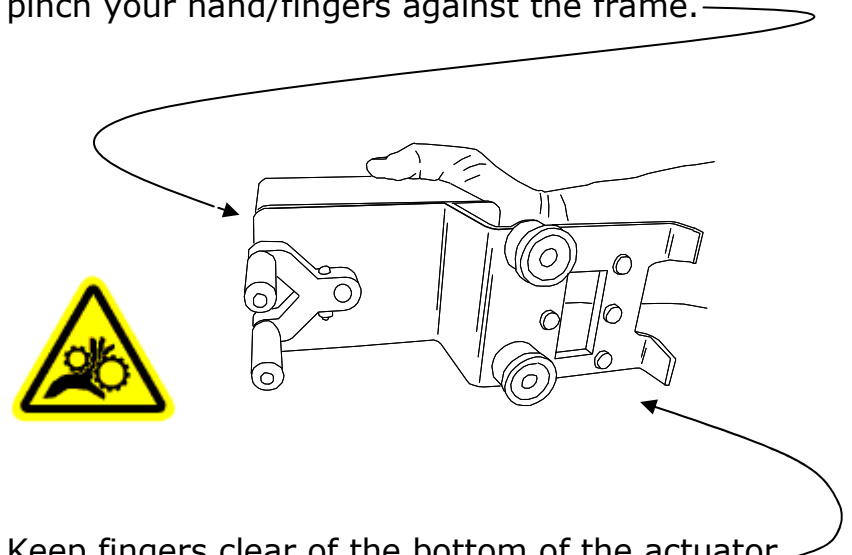

Keep fingers clear of the bottom of the actuator when the actuator is near a ferrous surface.

### 2.2 Strong magnets

The holding magnets are very strong. Keep magnetically-sensitive objects such as watches or computer disks away from the bottom of the actuator.

### 3.0 Battery Requirements

- Sixteen (16) AA alkaline cells are required – eight cells in each battery holder. Carefully observe polarity when installing cells.
- Rechargeable NiMh or NiCd can be used.

### 3.1 Battery Life

- A set of fresh alkaline cells should give over 700 operations.

### 3.2 Battery Replacement

- ALWAYS disconnect the control cable before replacing batteries to avoid possible static damage of the electronics!

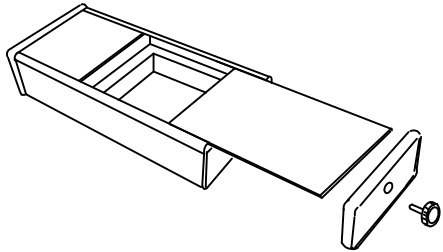

- Turn the control station upside down, remove the endplate retaining knob. Remove the endplate and slide the cover out as shown below.

### 3.3 To connect/disconnect batteries:

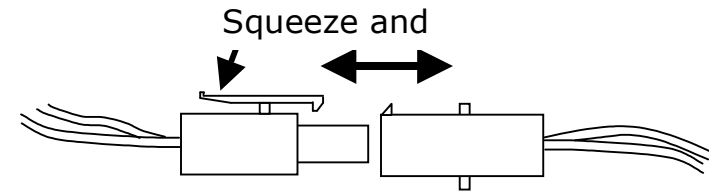

### 3.4 CAUTION: Static Discharge Potential

- To avoid possible damage to electronic components disconnect the control cable before replacing batteries.

## WARNING

To avoid possible damage to electronic components disconnect control cable before replacing batteries.

## 4.0 Operation

ALWAYS connect the control cable to the actuator BEFORE installing the Chicken Switch®.

### 4.1 Connecting the control cable:



1. Align the arrow on the cable end with the top of the receptacle.
2. Push in and engage the threads on the coupling nut and turn clockwise.
3. After one or two turns of the coupling nut, push in on the cable end. Repeat this until the connector is fully seated.
4. Use a similar technique of turn-stop-and-pull to disengage the cable ends.

### 4.2 Sequence of Operation:

1. Connect the control cable to the actuator and to the hand-held controller.
2. Verify that the actuator is in the neutral position.
3. Position the actuator over the Square D BoltLoc trip handle that is to be operated. The black rollers on the actuating arm should be on either side of the trip handle. The rectangular opening in the actuator should slide over the lock out device on the BoltLoc switch. (See diagrams in Section 4.3 for more information.)

**CAUTION:** Care must be given when installing the BL30 over the trip handle so as not to

inadvertently trip or close the switch while installing the actuator.

4. Use the handle on the BoltLoc switch to charge the trip and close springs.
5. Ensure you are at a safe distance from the circuit breaker that is to be operated.
6. To trip or close the BoltLoc switch, hold the ENABLE button while moving the control switch in the direction of the desired action.

### 4.3 Attaching and Removing the Actuator:

1. Carefully position the BL30 actuator over trip handle and lock out device

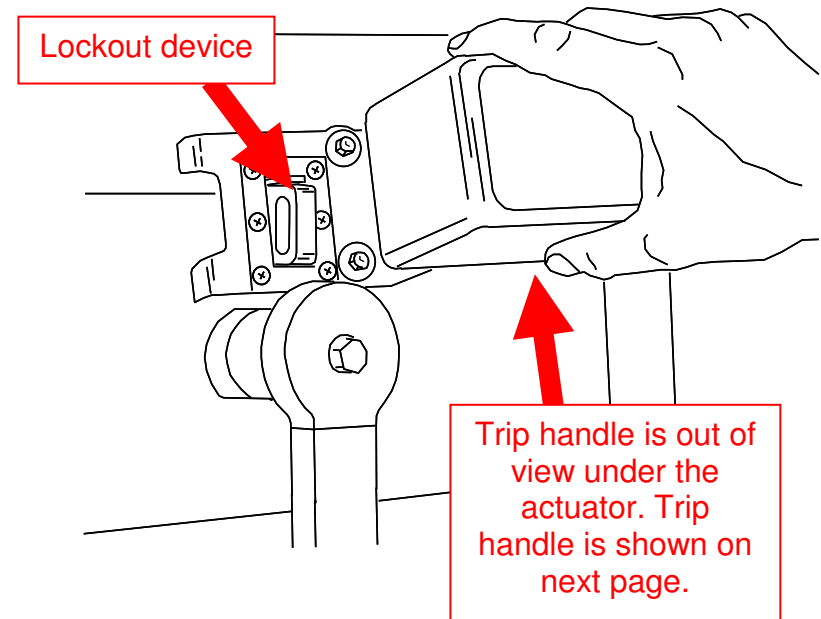

2. Once in place, the black rollers on the BL30 should straddle the BoltLoc trip handle and the magnets should be seated firmly.

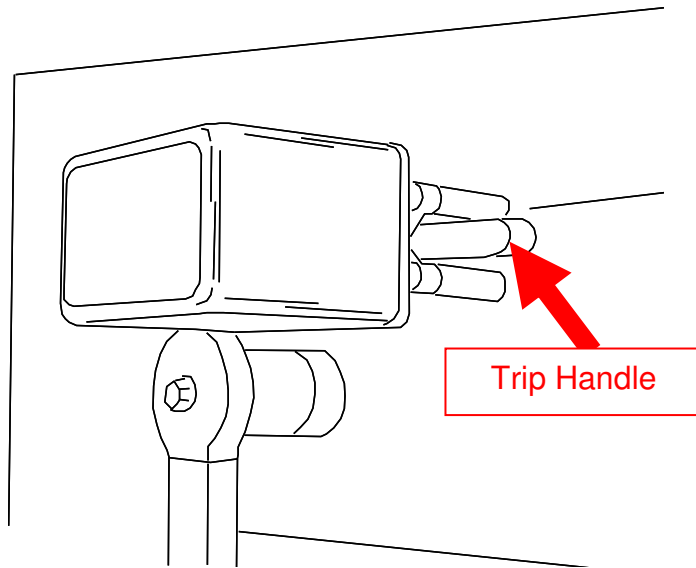

**NOTICE:**

The Chicken Switch® is designed as a *portable* device. It is not designed to remain with the control unit connected to the actuator for extended periods of time. To do so will deplete a fresh set of batteries in approximately four to five days.

**4.4 The indicator lights & controls:**

NOTE: the indicator lights only work when the ENABLE button is depressed.

**GREEN**: indicates the actuator is being commanded to rotate in the TRIP direction (CCW).

**RED**: indicates the actuator is being commanded to rotate in the CLOSE direction (CW).

**YELLOW**: indicates the actuator is in the neutral position and the controller and batteries are healthy.

**Rapidly blinking YELLOW** indicates the battery voltage with zero load has fallen to an unacceptable level. Operation is inhibited until batteries with an acceptable voltage level are installed.

**The ENABLE button:**

The Enable button must be continuously depressed in order to command the actuator.

Releasing the enable button has the same affect as returning the selector switch to neutral – the actuator moves to neutral.

**Note:**

If the control switch is held in the trip or close position for longer than approximately 3 seconds the drive motor will de-energize and the arm will remain in driven position. When the control switch or the enable button is released, the motor will energize to drive the actuator arm to neutral.

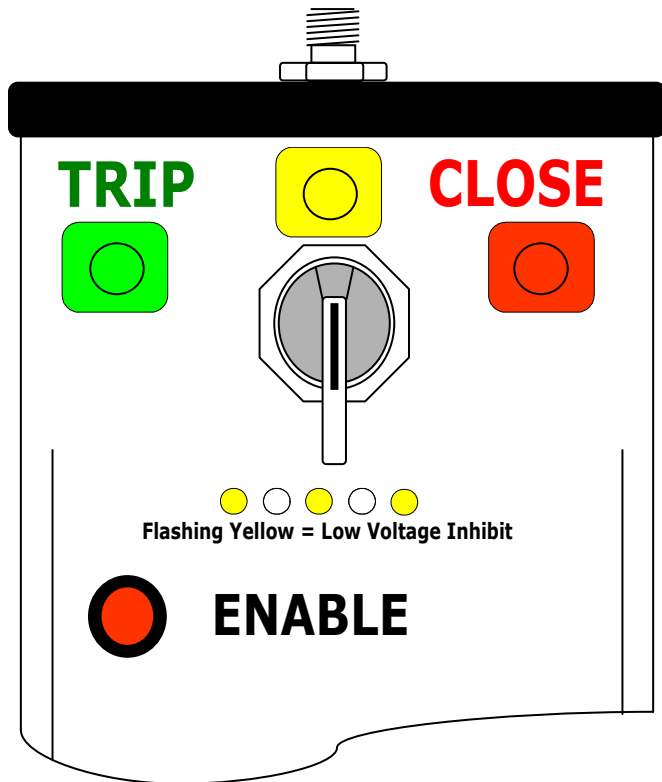

## 5.0 Care and Storage

### 5.1 Cleaning the magnets

Over a period of time, the magnets may attract ferrous debris. Exercise care to avoid setting the actuator where the magnets might attract debris. If this does occur, use a paper towel or nylon bristle brush to clean the face of the magnets. Keeping the magnet faces clean ensures that maximum holding power is maintained.

### 5.2 Storage

Remove all batteries from the control station if the device will not be used for longer than 6 months.

Never store the batteries where the ambient temperature might exceed 110° F.

Avoid getting the unit wet or storing it in a high humidity location.

## 6.0 Warranty

MarTek Ltd. guarantees all products manufactured by MarTek Ltd. only against defects in materials and/or workmanship for a period of twelve (12) months commencing on the date the product is received by the customer. THIS WARRANTY IS IN LIEU OF ALL OTHER EXPRESS OR IMPLIED WARRANTIES INCLUDING THOSE OF MERCHANTABILITY AND FITNESS FOR A PARTICULAR PURPOSE.

MarTek Ltd. will, at its option and its cost (including shipping expenses for return and re-delivery), repair, replace or refund the purchase price of any product manufactured by MarTek Ltd. which has a defect in materials and/or workmanship. THIS IS CUSTOMER'S EXCLUSIVE REMEDY FOR BREACH OF WARRANTY. IN NO EVENT WILL MARTEK LTD'S LIABILITY FOR DAMAGES (WHETHER ARISING FROM BREACH OF CONTRACT OR WARRANTY, NEGLIGENCE, STRICT LIABILITY OR OTHERWISE) EXCEED THE PURCHASE PRICE OF THE PRODUCT CONCERNED NOR WILL MARTEK LTD. BE LIABLE FOR PUNITIVE, INCIDENTAL, CONSEQUENTIAL OR SPECIAL DAMAGES (INCLUDING WITHOUT LIMITATION LOST PROFITS) EVEN IF ADVISED OF THE POSSIBILITY OF SUCH DAMAGES.

MarTek Ltd. reserves the right to disallow warranty repairs if the unit has been disassembled or misused, as determined by MarTek Ltd. in good faith. Please contact us at (800)-248-4958 for a return authorization.

**MarTek Ltd.**  
4806 Chimney Drive  
Charleston, WV 25302  
1-304-965-9220  
1-800-248-4958

## 7.0

### Specifications

#### MECHANICAL

Holding magnets:	Two magnets, each rated @ 36.9 lbs force, 13.200 Gauss.
Gearmotor:	All metal gears, in a formed metallic housing. DC brushed, permanent magnet motor with .375 inch diameter shaft (9.5 mm).
Projected life:	20,000 operations

#### ELECTRICAL

Operating voltage:	24 volts DC
Fuse:	5 amp, quick-blow, AGC-5
Power supply:	16 AA alkaline disposable batteries. When used properly, one set of batteries should yield over 700 operations.
Control Cable:	30 feet in length (9.1 meters), 5-conductor, extra-flexible, PUR insulation
Controller:	Requires two-hand operation. The 'enable' button must be depressed while rotating the controller selector switch.  A separate toggle switch allows the user to select between two levels of rotation (of the actuator).  A programmable micro-controller manages control inputs, motor functions, monitors and limits mechanical travel and performs timing functions to protect the motor in a stalled condition.  An intelligent 'H-bridge' motor driver provides start/stop/braking motor functions. The H-bridge has integral thermal shutdown protection.

**MarTek Ltd.**

**4806 Chimney Drive  
Charleston, WV 25302**

**1-800-248-4958**

**[www.chickenswitch.com](http://www.chickenswitch.com)**

Chicken Switch is a Registered Trademark of MarTek Ltd.

Copyright 2004-2013, MarTek Ltd. All rights reserved.